

HP Series Wafer 2 1/2" - 8" with Gear Class 150 and 300

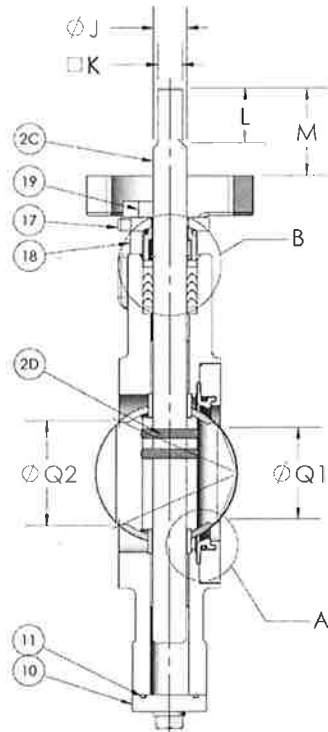

VALVE SHOWN OPEN

2.5" - 8" 150/300LB WAFER WITH GEAR			
ITEM NO.	PARTS NAME	MATERIAL	SPECIFICATION
1	BODY	A. CARBON STEEL	ASTM A216 GR. WCB
		B. STAINLESS STEEL	ASTM A351 GR. CF8M
2	STEM & DISC ASSEMBLY		
	2B. DISC	STAINLESS STEEL	ASTM A351 GR. CF8M
	2C. STEM	STAINLESS STEEL	17-4PH H1150
	2D. TAPER PIN	18-8 STAINLESS STEEL	COMMERCIAL
3	STEM RETAINER	304 STAINLESS STEEL	COMMERCIAL
4	SEAT RETAINER RING	A. CARBON STEEL	ASTM A515 GR. 70
		B. STAINLESS STEEL	ASTM A240 TY.316
5	SOCKET HEAD CAP SCREW	STAINLESS STEEL	ASTM A193 GR. B8M
6	SEAT	A. PTFE COMMERCIAL	COMMERCIAL
		B. 15% GLS. FLD. PTFE	COMMERCIAL
		C. UHMWPE	COMMERCIAL
7	SEAT SPRING	STAINLESS STEEL	COMMERCIAL
8	DISC SPACER	316 STAINLESS STEEL	COMMERCIAL
9	BEARING	STAINLESS STEEL - PTFE COATED	COMMERCIAL
10	BOTTOM CAP	STAINLESS STEEL	ASTM A351 GR. CF8M
11	BOTTOM SEAL	GRAPHITE	COMMERCIAL
12	HEX HEAD CAP SCREW	STAINLESS STEEL	ASTM A193, GR. B8M
13	SPLIT LOCKWASHER	STAINLESS STEEL	COMMERCIAL
14	PACKING V-RING SET	A. PTFE COMMERCIAL	COMMERCIAL
		B. GRAPHITE	COMMERCIAL
15	PACKING WASHER	304 STAINLESS STEEL	COMMERCIAL
16	GLAND FOLLOWER	STAINLESS STEEL	ASTM A351 GR. CF8M
17	GLAND RETAINER	STAINLESS STEEL	ASTM A351 GR. CF8M
18	STUD	STAINLESS STEEL	ASTM A193 GR. B8M
19	HEAVY HEX NUT	STAINLESS STEEL	ASTM A194 GR. 8M
20	SOCKET HEAD CAP SCREW	STAINLESS STEEL	ASTM A193 GR. B8M
21	SPLIT LOCKWASHER	STAINLESS STEEL	COMMERCIAL
22	MOUNTING PLATE	STAINLESS STEEL	COMMERCIAL
23	GEAR OPERATOR		

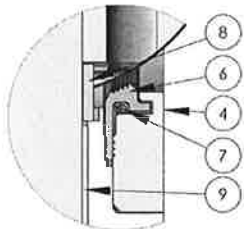

DETAIL A

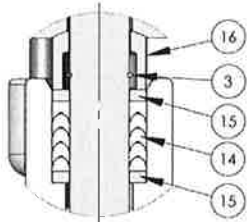

DETAIL B

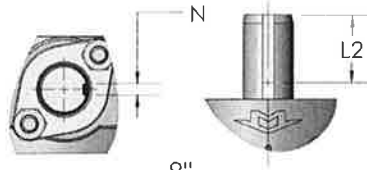

8" STEM DETAIL

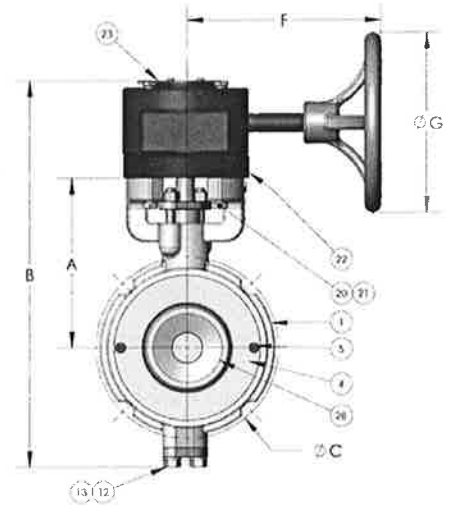
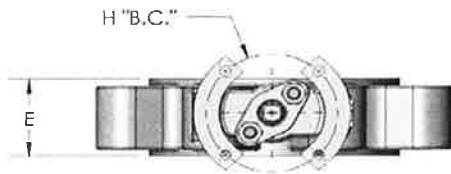

3" 150/300 HP WAFER SHOWN

2.5" - 8" 150/300LB WAFER WITH GEAR															
VALVE SIZE	VALVE DIMENSIONS					HANDWHEEL	TOP WORKS	STEM CONNECTION					CORE DIMS		
	"A" HEIGHT	"B" HEIGHT	"C" B.C.	"E" FACE	"F"			"G" DIA	"H" B.C.	"J" ØSTEM	"K" SQUARE	"L" LENGTH	"L2"	"M" LENGTH	"N"
2.5" 150/300 WAFER	5.59	13.57	5.50	1.88	6.37	6	3.25	0.62	0.46	1.02	N/A	1.64	N/A	1.72	1.97
3" 150/300 WAFER	5.59	12.72	6.00	1.88	6.37	6	3.25	0.62	0.46	1.02	N/A	1.72	N/A	2.28	2.47
4" 150/300 WAFER	6.25	14.25	7.50	2.13	6.37	6	3.25	0.62	0.46	1.02	N/A	1.56	N/A	3.06	3.53
5" 150 WAFER	7.69	18.83	8.50	2.13	6.02	9	4.25	0.87	0.64	1.04	N/A	1.70	N/A	4.35	4.47
5" 300 WAFER	7.69	16.94	9.25	2.13	6.52	9	4.25	0.87	0.64	1.04	N/A	1.70	N/A	4.35	4.47
6" 150 WAFER	7.69	18.69	9.50	2.25	6.02	9	4.25	0.87	0.64	1.04	N/A	1.70	N/A	5.33	5.43
6" 300 WAFER	7.69	18.50	9.50	2.25	6.02	9	4.25	0.87	0.64	1.04	N/A	1.67	N/A	5.33	5.43
8" 150 WAFER	9.51	21.67	11.75	2.63	7.93	12	4.75	1.12	N/A	N/A	1.50	1.86	0.25	7.10	7.37
8" 300 WAFER	9.51	21.67	13.00	2.88	7.93	12	4.75	1.12	N/A	N/A	1.50	1.86	0.25	7.10	7.20



HP Series: Milwaukee Valve Company High Performance Butterfly Valves

Features and Benefits

- Double offset seat/disc/stem geometry to provide superior sealing with minimal seat contact and wear.
- Machined, tapered seat multiple sealing edges.
- Single piece shaft and disc designed for maximum strength and Cv.
- Internally cast disc position stop to prevent disc over travel while maintaining optimum disc/seat contact.
- Stem is centered in the adjustable stem packing by oversized bearings eliminating stem leakage and fugitive emissions.
- Disc spacers to center disc in seat to eliminate seat distortion.
- Blow out proof stem to prevent injury and product loss.
- Combination mechanical and pressure energized seal design for repeatable and reliable sealing performance and extended cycle life
- Sealing retaining ring designed for double dead end service (lug style) and provides easy removal for seat replacement.
- Stem/disc connection allows minimal loss motion and high strength.

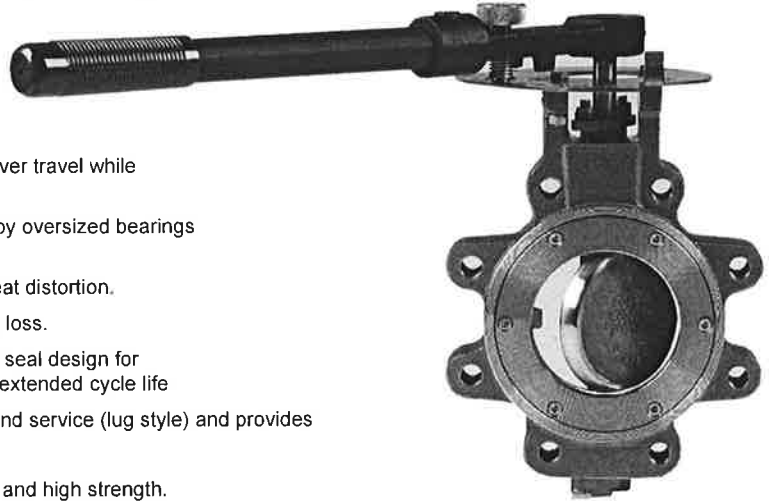

H.P. Lug Pattern

Product Range

Size/ASME Class: 2-1/2"-24", Class 150 & 300
Body Configuration: Water and Lug

Operators Available

10 Position Lever Handle, Gear Operators, Pneumatic and Electric Actuators

Material of Standard Construction

Body Carbon Steel or 316 Stainless Steel
Disc 316 Stainless Steel
Stem 17-4 PH Stainless Steel
Bearing Stainless backed RTFE
Seat RTFE/Stainless Garter Spring

Specifications

Valve Sizes 2 1/2" through 24"

Flanged Ends Connections per ANSI B16.5.

Valve face to face dimension per MSS-SP-68.

Valve bodies are cast high quality steel, with standard availability in ASTM-A-216 WCB CS and ASTM A-351 CF8M SS. Body wall thickness meets ASME/ANSI B16/34 and complies with quality standard for steel casting MSS-SP-55.

High performance valve meets the requirements of MSS-SP-68 for double offset design.

Valve pressure tests meet MSS-SP-61.

Valve testing and inspection meets API 598.

Tagging meets the requirements of MSS-SP-25 and API 609B.

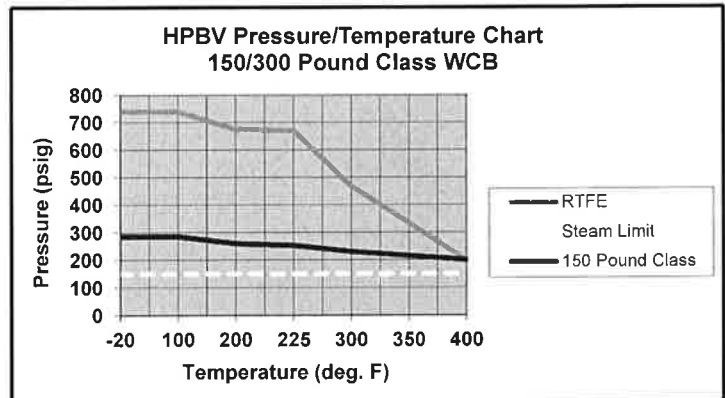

Pressure Ratings*

(Cold Working Pressure)

	2-1/2" through 24"	2-1/2" through 16"
Carbon Steel	285 psi	740 psi
Stainless Steel	275 psi	720 psi

*Valve is rated @150 PSI steam for on & off application and 50 PSI modulating service.

HOW TO ORDER MILWAUKEE VALVES HP SERIES HIGH PERFORMANCE BUTTERFLY VALVE										
SERIES	ANSI CLASS	BODY STYLE	BODY MATERIAL	DISC MATERIAL	STEM MATERIAL	SEAT MATERIAL	STEM PACKING	OPERATOR	EXT. OPTIONS	SIZE
XX	X	X	X	X	X	X	X	X	XX	XXX
HP	1-150 3-300	L-LUG W-WAFER	C-WCB S-CF8M	S-CF8M	4-17.4 SS 5-316 SS	1-PTFE 2-RPTFE 4-UHMWPE	1-PTFE G-GRAPHITE	1-BARE STEM 2-LEVER-LOCK 3-GEAR OP 4-ELECT 5-PNEUMATIC 6-Epoxy Cld. Gear Op 7-Epoxy Cld. Lever Lock	A-Assemble Dry C-Chlorine Clean E-Extended Mounting L-Locking O-Oxygen Clean S-Stainless Steel Seat Retainer U-Assembled in USA	025-240
PART NUMBER EXAMPLE										
HP1LC4111 040 = 4 INCH, HIGH PERFORMANCE, CLASS 150, LUG PATTERN, CARBON STEEL BODY, 17-4 STEM, PTFE SEAT, PTFE PACKING, BARE STEM WITH NO EXT OPTIONS										

