



A CSW Industrials Company

TRUaire A290 Series

Aluminum Fixed Bar 3/4" Blade Spacing
Fixed Hinge Return Air Filter Grille

Model: _____ Size: _____

Project Information:

Job Name: _____

Location: _____

Engineer: _____

Submitted to: _____

For: Reference Approval Construction

Submitted by: _____

Reference: _____

Submittal Information:

Approval: _____

Date: _____

Construction: _____

Unit #: _____

Drawing #: _____

Construction Options

- 1" Deep Filter
- 2" Deep Filter
- 30° Blade Pitch
- 45° Blade Pitch

(Sec. I) Features

- Pristine White Powder Coat Finish
- #8 x 2" Long Mounting Hardware

Filter Depth	Dim "A"
1"	1 7/8"
2"	2 1/16"

(Fig. I) Product Image:

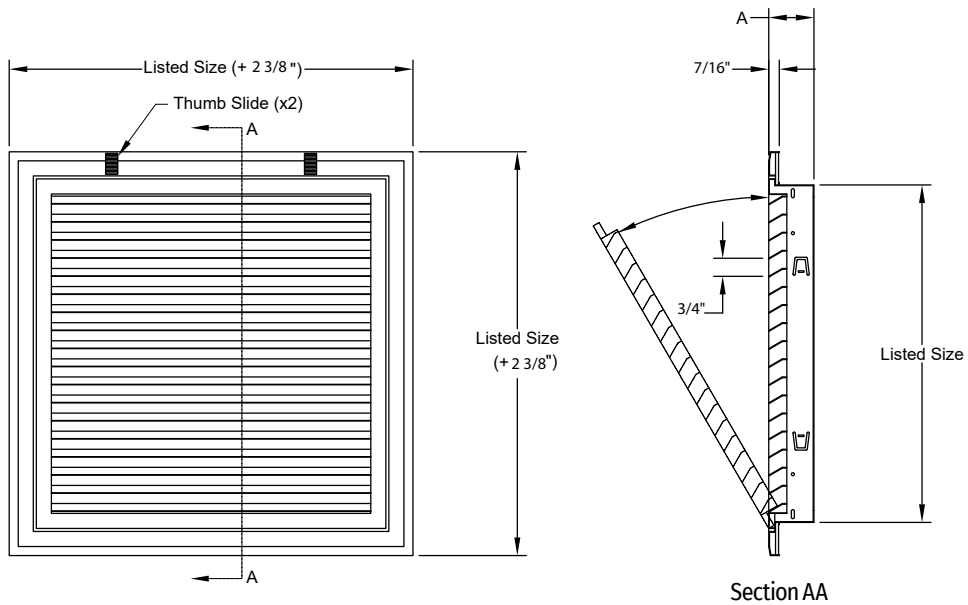

RectorSeal® • 2601 Spenwick Drive • Houston, TX 77055 • 800-231-3345 • rectorseal.com

A CSW Industrials Company. RectorSeal, the logos and other trademarks are property of RectorSeal, LLC, its affiliates or its licensors and are protected by copyright, trademark and other intellectual property laws, and may not be used without permission. RectorSeal reserves the right to change specifications without prior notice. ©2023 RectorSeal. All rights reserved. R50956-0323