

FTS-150C

NFPA-13D Residential Package

Maximum Suction Pressure: 74PSI

System Specifications

Motor

- 1.5 Horsepower Electric
- 240 Volt, 8.1 Amp
- Single Phase
- 3450

Pump

- 316 Series Stainless Steel Volute
- Stainless Steel Impeller
- 1 1/2" Suction
- 1 1/4" Discharge
- 125 PSI Max Working Pressure

Controls

- 240 Volt
- Minimum Run Timer
- Pressure Switch Operated Contactor
- HOA Toggle Switch (Hand, Off, Auto)

Dimensions (Approximate)

- 21" Length
- 19" Height
- 12" Width
- 65 Pounds

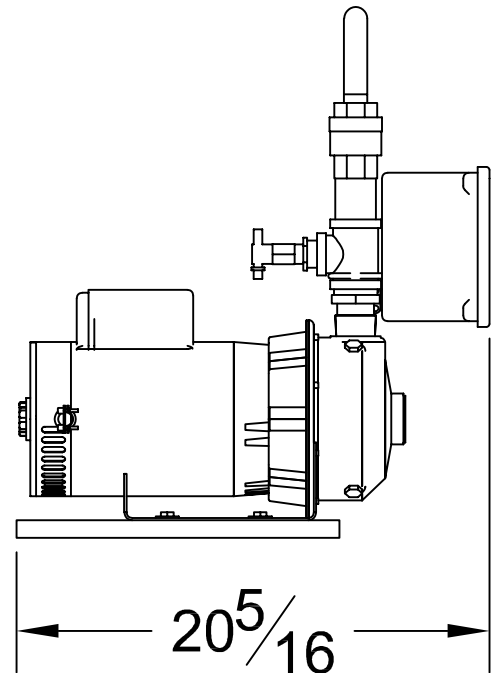
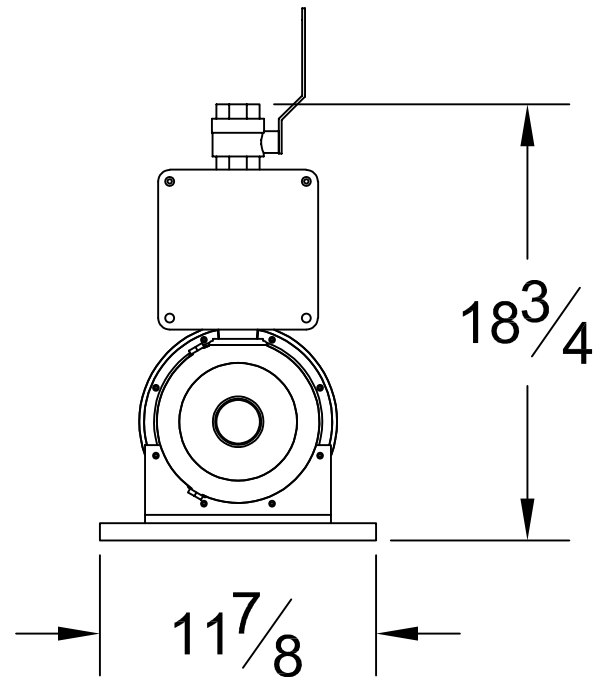

Performance

Performance values based on multiple pump tests. Not for certification purposes.

GPM	0	20	25	30	35	40
PSI	47	45	44	43	41	40