

For Health Hazard Applications

Job Name _____
 Job Location _____
 Engineer _____
 Approval _____

Contractor _____
 Approval _____
 Contractor's P.O. No. _____
 Representative _____

LEAD FREE*

Series LF909 Reduced Pressure Zone Assemblies

LF909 Sizes: ¾", 1" (20, 25mm)

LF909M1 Sizes: 1¼", 1½", 2" (32, 40, 50mm)

Series LF909 Reduced Pressure Zone Assemblies are designed to provide superior cross-connection control protection of the potable water supply in accordance with national plumbing codes and containment control for water authority requirements. This series can be utilized in a variety of installations, including health hazard cross-connections in plumbing systems or for containment at the service line entrance. The LF909 features Lead Free* construction to comply with Lead Free* installation requirements. With its exclusive, design incorporating the "air-in/water-out" principle it provides maximum relief valve discharge during the emergency conditions of combined backsiphonage and backpressure with both checks fouled. Model LF909QT, standardly furnished with full port, resilient seated and Lead Free* cast copper silicon alloy ball valve shutoffs. Sizes ¾" and 1" (20 and 25mm) shutoffs have tee handles.

Features

- Modular design
- Replaceable seats
- Compact for installation ease
- Horizontal or vertical (up or down) installation on limited sizes only
- No special tools required for servicing

Specifications

A Reduced Pressure Zone Assembly shall be installed at each cross-connection to prevent backsiphonage and backpressure of hazardous materials into the potable water supply. The assembly shall consist of a pressure differential relief valve located in a zone between two positive seating check valves. Backsiphonage protection shall include provision to admit air directly into the reduced pressure zone via a separate channel from the water discharge channel, or directly into the supply pipe via a separate vent. The assembly shall be constructed using Lead Free* cast copper silicon materials. The Lead Free* reduced pressure zone assembly shall comply with state codes and standards, where applicable, requiring reduced lead content. The assembly shall include two tightly closing shutoff valves before and after the assembly, test cocks and a protective strainer upstream of the No. 1 shutoff valve. The assembly (specify Model LF909 for temperatures up to 140°F (60°C) or Model LF909HW for temperatures up to 210°F (99°C)) shall meet the requirements of ASSE Std. 1013; AWWA Std. C-511-92 CSA B64.4; FCCCHR of USC Manual Section 10. Listed by IAPMO (UPC). SBCCI (Standard Plumbing code). The assembly shall be a Watts LF909QTS or LF909QTSHW.

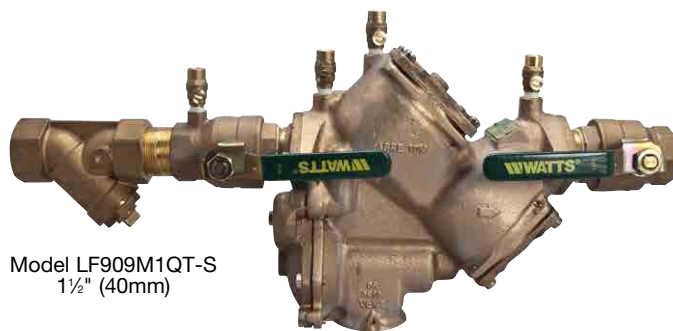

Model LF909M1QT-S
1½" (40mm)

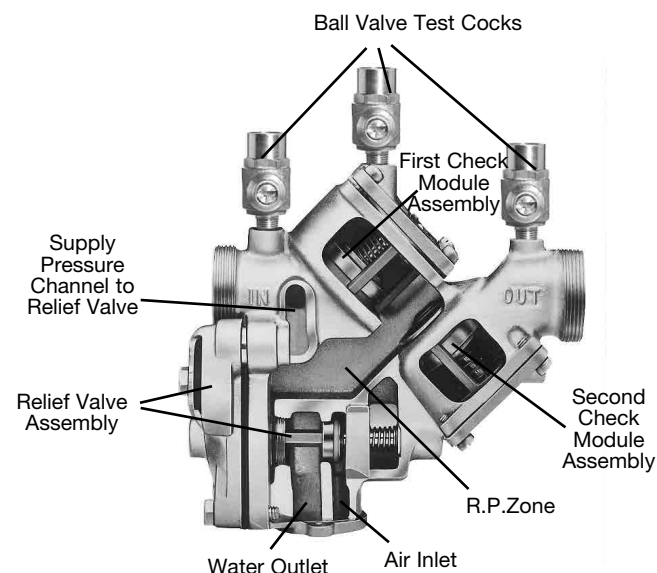

**Now Available
WattsBox Insulated Enclosures.**

For more information, send for literature ES-WB.

NOTICE

The information contained herein is not intended to replace the full product installation and safety information available or the experience of a trained product installer. You are required to thoroughly read all installation instructions and product safety information before beginning the installation of this product.

*The wetted surface of this product contacted by consumable water contains less than 0.25% of lead by weight.

Watts product specifications in U.S. customary units and metric are approximate and are provided for reference only. For precise measurements, please contact Watts Technical Service. Watts reserves the right to change or modify product design, construction, specifications, or materials without prior notice and without incurring any obligation to make such changes and modifications on Watts products previously or subsequently sold.

WATTS®

Models

Suffix

QT	Quarter-turn ball valves
S	Bronze strainer
HW	Stainless steel check modules for hot and harsh water conditions

NOTICE

The installation of a drain line is recommended. When installing a drain line, an air gap is necessary.

Materials

Body: Lead Free* Cast Copper Silicon Alloy

Check Seats: 909 Celcon®

Relief Valve Seats: Stainless Steel 909HW

Test Cocks: Lead Free* Cast Copper Silicon Alloy

Celcon® is a registered trademark of Celanese, Limited

Connections

¾" – 1" (19 – 25mm) 909-NPT Female threaded body connection

1¼" – 2" (32 – 50mm) 909-M1-NPT Male threaded body connection

Standards

AWWA C-511-92

FCCCHR of USC Manual Section 10

IAPMO (UPC), SBCCI (Standard Plumbing code)

Tested and Certified by NSF International

Approvals

Listed by IAPMO

Listed by SBCCI



‡Approved by the Foundation for Cross-Connection Control and Hydraulic Research at the University of Southern California. (QT and S Models)

Vertical "flow-up" approval only on ¾" (20mm) and 1" (25mm) sizes (model LF909QT).

Pressure – Temperature

Temperature Range: 33°F – 140°F (0.5°C – 60°C) continuous, 180°F (82°C) intermittent

Maximum Working Pressure: 175psi (12.1 bar)

Series LF909HW:

Temperature Range: 33°F – 210°F (0.5°C – 99°C)

Maximum Working Pressure: 175psi (12.1 bar)

How it Operates

The unique relief valve construction incorporates two channels: one for air, one for water. When the relief valve opens, as in the accompanying air-in/water-out diagram, the right-hand channel admits air to the top of the reduced pressure zone, relieving the zone vacuum. The channel on the left then drains the zone to atmosphere. Therefore, if both check valves foul, and simultaneous negative supply and positive backpressure develop, the relief valve uses the air-in/water-out principle to stop potential backflow.

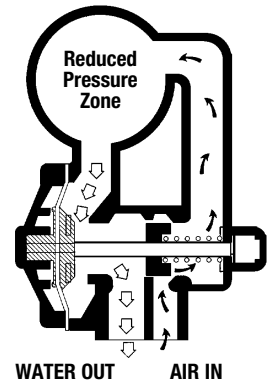

Dimensions – Weights

When installing a drain line use 909AG series Air Gaps on Series 909 backflow preventers. ††909EL series elbows are for air gaps on backflow preventers in vertical installations.

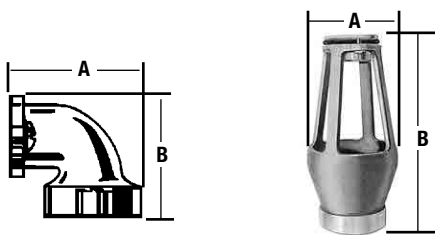

Series 909AG Air Gaps

Iron Body No.	909 DRAIN Desc.	SIZES		DIMENSIONS		WEIGHTS					
		in.	mm	in.	mm	in.	mm	lbs.	kg.		
909AG-C	Air Gap	¾, 1	19, 25	1	25	¾	83	4 7/8	124	1 ½	.7
909EL-C	Elbow††	¾, 1	19, 25	–	–	2 ¾	60	2 ¾	60	¾	.2
909AG-F	Air Gap	1 ¼-2	32-50	2	50	4 ¾	111	6 ¾	171	3 ¾	1.5
909EL-F	Elbow††	1 ¼-2	32-50	–	–	3 ¾	92	3 ¾	92	2	.9

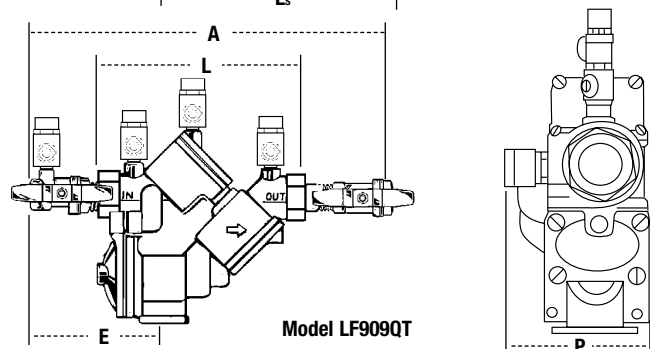
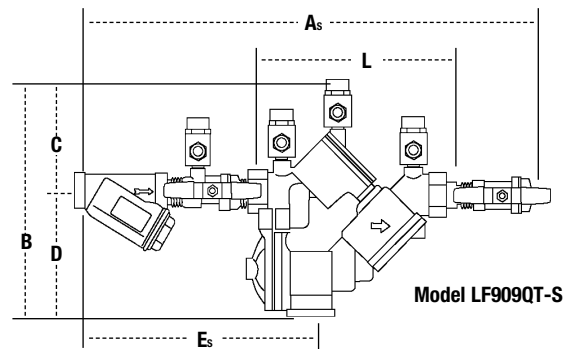

Capacity

As compiled from documented Foundation for Cross-Connection Control and Hydraulic Research of the University of Southern California lab tests.

◇ Typical maximum system flow rate (7.5 feet/sec.)

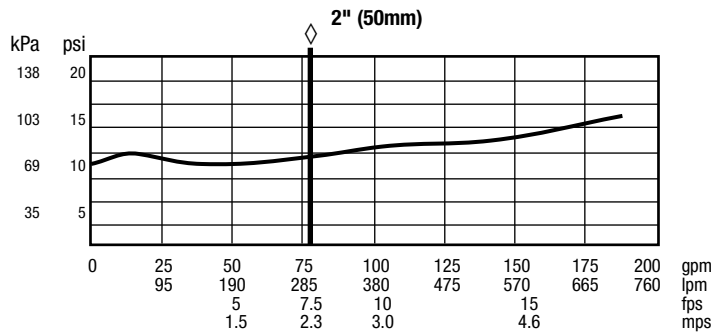
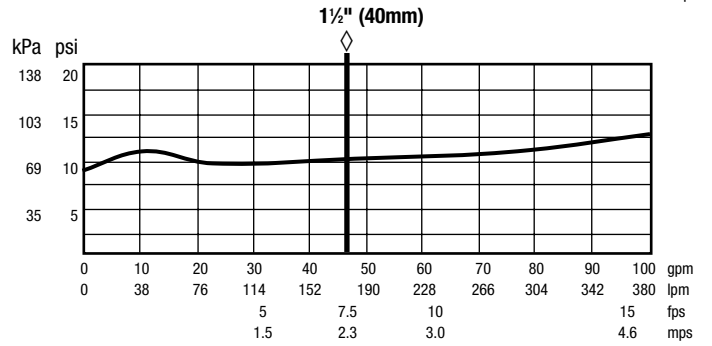
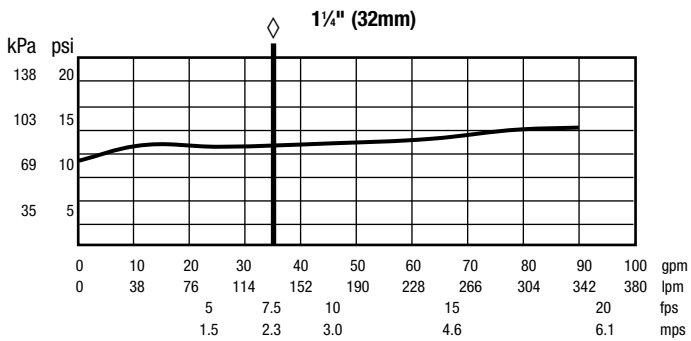
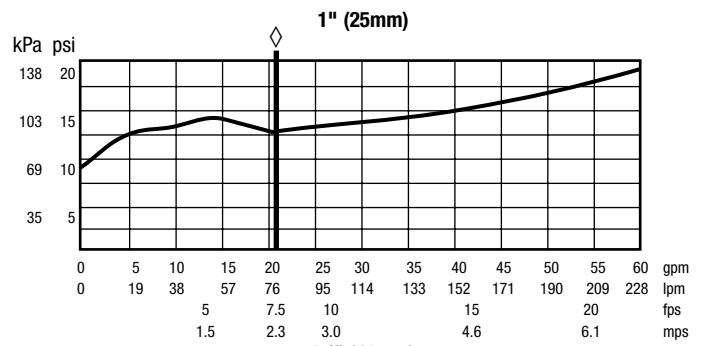
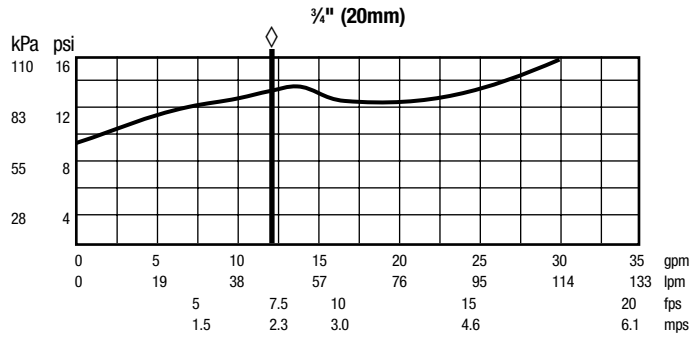

LF909QT, LF909QT-S

SIZE (DN)	DIMENSIONS											WEIGHT										
	A		As		B		C		D		E		Es		L		P		QT		QT-S	
	in.	mm	in.	mm	in.	mm	in.	mm	in.	mm	in.	mm	in.	mm	in.	mm	in.	mm	lbs.	kgs.	lbs.	kgs.
3/4"	14 3/8	365	18 1/16	459	8 3/4	222	4	102	4 3/4	121	6 3/4	171	10 3/16	259	7 5/16	186	3 3/8	98	14	6.4	15.6	7.1
1"	15 3/8	391	19 3/8	498	8 3/4	222	4	102	4 3/4	121	7	178	11	279	7 5/16	186	3 3/8	98	15	6.8	17.5	7.9
1 1/4" M1	18 1/2	470	23 3/16	595	11 1/8	295	5 1/2	140	6 1/2	165	7 1/2	191	12 3/16	310	10 3/8	264	5 1/4	133	40	18.1	42.8	19.4
1 1/2" M1	19	483	24 3/8	619	11 1/8	295	5 1/2	140	6 1/2	165	7 1/2	191	12 3/8	321	10 3/8	264	5 1/4	133	40	18.1	44.0	20.0
2" M1	19 1/2	495	25 1/16	659	11 1/8	295	5 1/2	140	6 1/2	165	7 3/4	197	13 1/16	354	10 3/8	264	5 1/4	133	40	18.1	47.4	21.5

Subscript 'S' = strainer model