

SPECIFICATIONS

Notes:

1. 6" plain end inlet/outlet
2. Unit weight - w/ cast iron covers: 1,290 lbs. (for wet weight add 12,525 lbs.)
3. Maximum operating temperature: 150° F continuous
4. Capacities - Liquid: 1,500 gal.;
Grease: 10,061 lbs. (1,379 gal.) @100GPM
Grease: 9,446 lbs. (1,294 gal.) @200GPM
Solids: 318 gal.
5. Satisfies Miami DERM 99% efficiency requirements; retaining the following capacities at 99% efficiency:
9,897 lbs. (1,356 gal.) @100GPM
8,093 lbs. (1,109 gal.) @200GPM
6. For gravity drainage applications only.
7. Do not use for pressure applications.
8. Cover placement allows full access to tank for proper maintenance.
9. Vent not required unless per local code.
10. Engineered inlet and outlet diffusers with inspection ports are removable to inspect / clean piping.
11. Integral air relief / Anti-siphon / Sampling access.
12. Adjustable cover adapters provide up to 4" of additional height.
13. Designed for below-grade, above-grade, indoor or outdoor installations.
14. Safety Star®, access restrictor built into each cover adapter, prevents accidental entry to tanks (450 lb rating).

ENGINEER SPECIFICATION GUIDE

Schier Great Basin™ grease interceptor model # GB-1500 shall be lifetime guaranteed and made in USA of seamless, molded polyethylene with minimum 7/16" uniform wall thickness. Interceptor shall be furnished for above or below-grade installation with adjustable cover adapter and Safety Star® access restrictor built into each cover adapter. Interceptor shall be certified to ASME A112.14.3 (Type D) and CSA B481.1 as well as certified to IAPMO/ANSI Z1001-2021. Interceptor flow rate shall be 100 GPM or 200 GPM. Interceptor grease capacity shall be 10,061 lbs. Cover shall provide water/gas-tight seal and have minimum 16,000 lbs. load capacity.

CERTIFIED PERFORMANCE

Great Basin™ hydromechanical grease interceptors are third party performance-tested and listed by IAPMO to ASME #A112.14.3 and CSA B481.1 grease interceptor standards and greatly exceed requirements for grease separation and storage. They are compliant to the Uniform Plumbing Code and the International Plumbing Code.

Type D certification does not require a flow control



Satisfies Miami DERM 99% efficiency requirements. Product labels are permanently attached to inside and outside of unit for easy viewing.

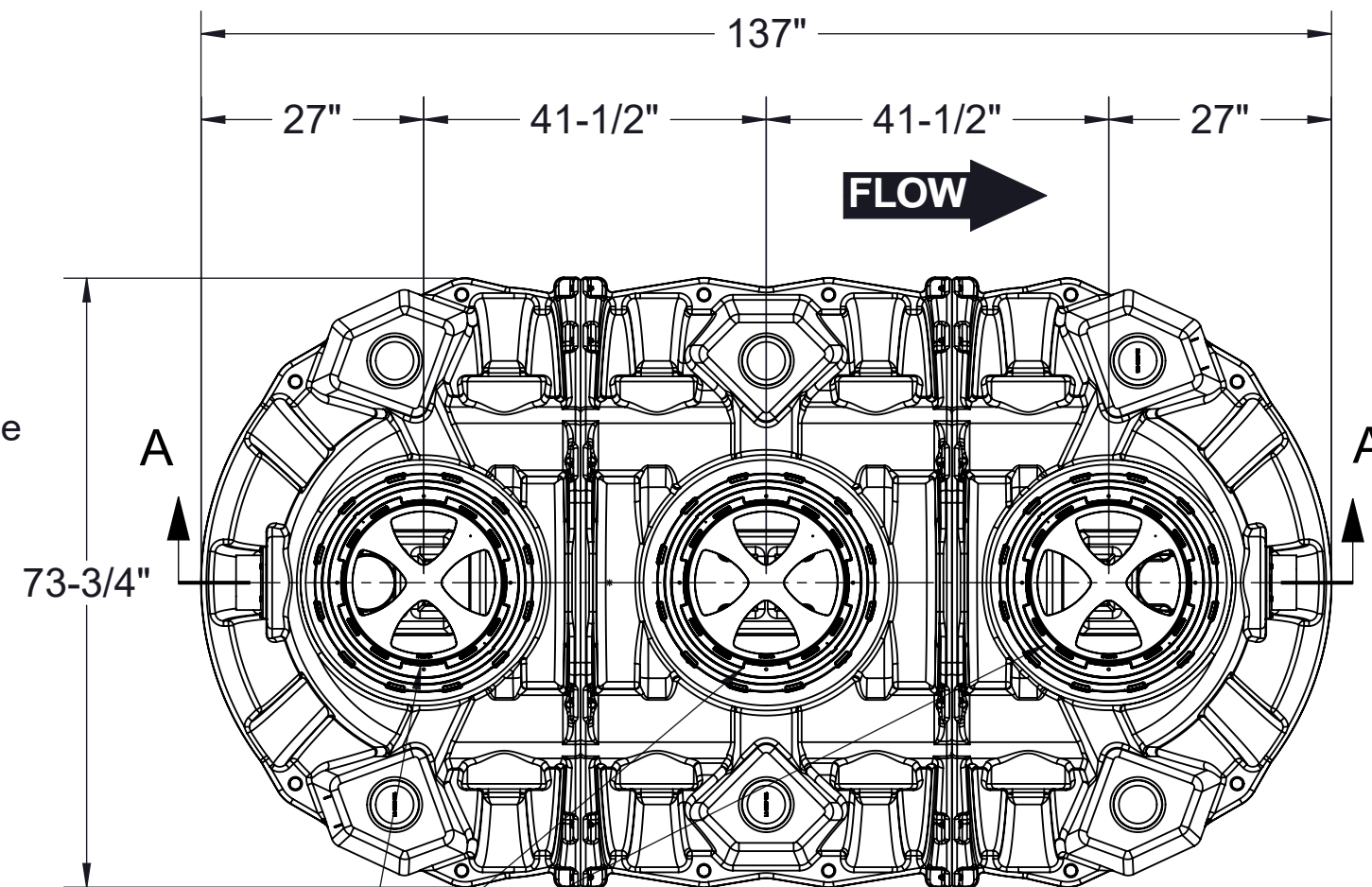

TOP VIEW
(COVERS REMOVED FOR CLARITY)

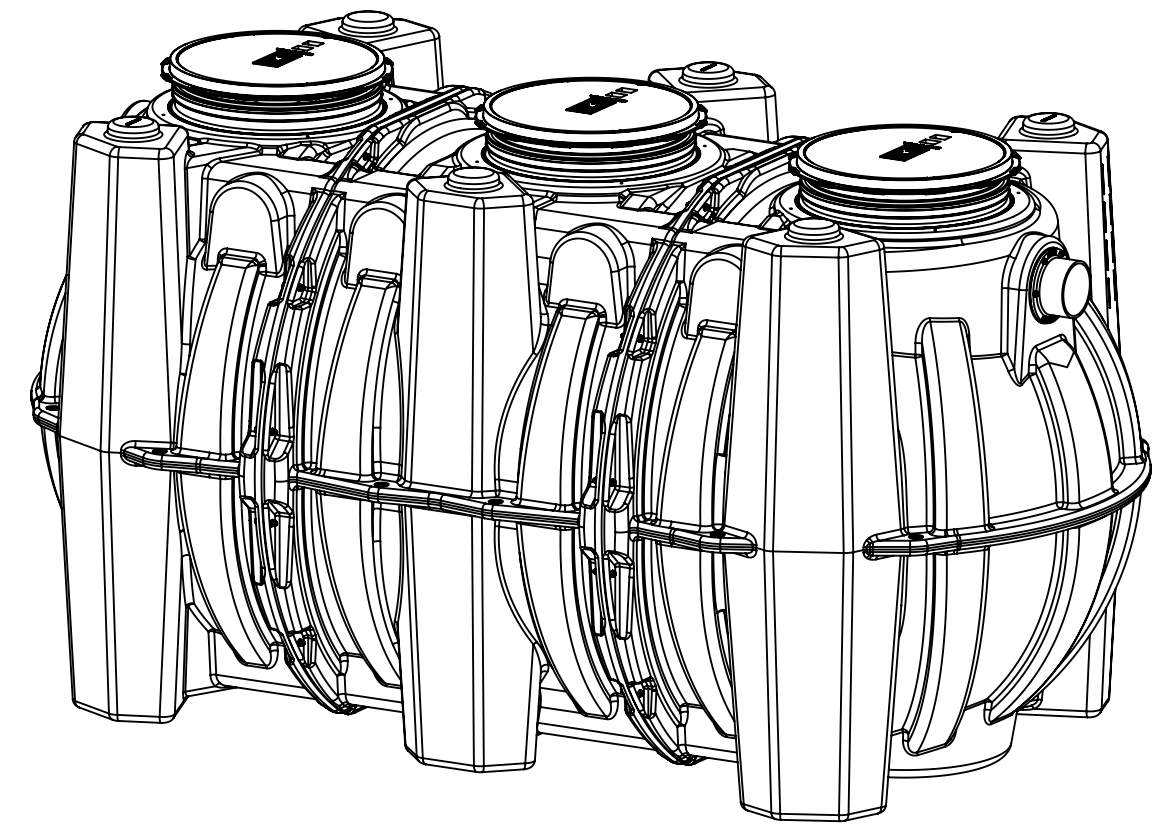

ISOMETRIC VIEW

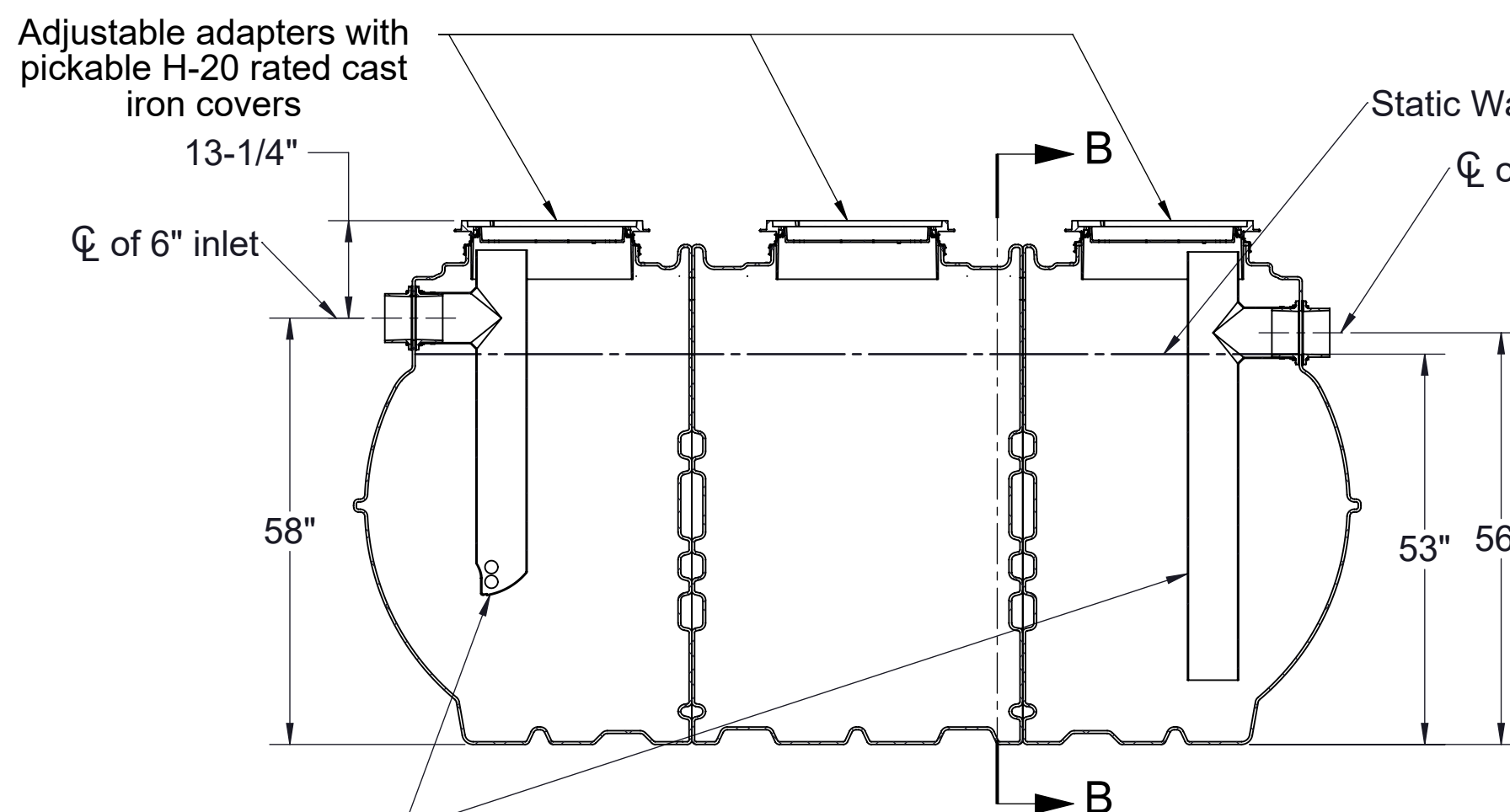

SECTION A-A

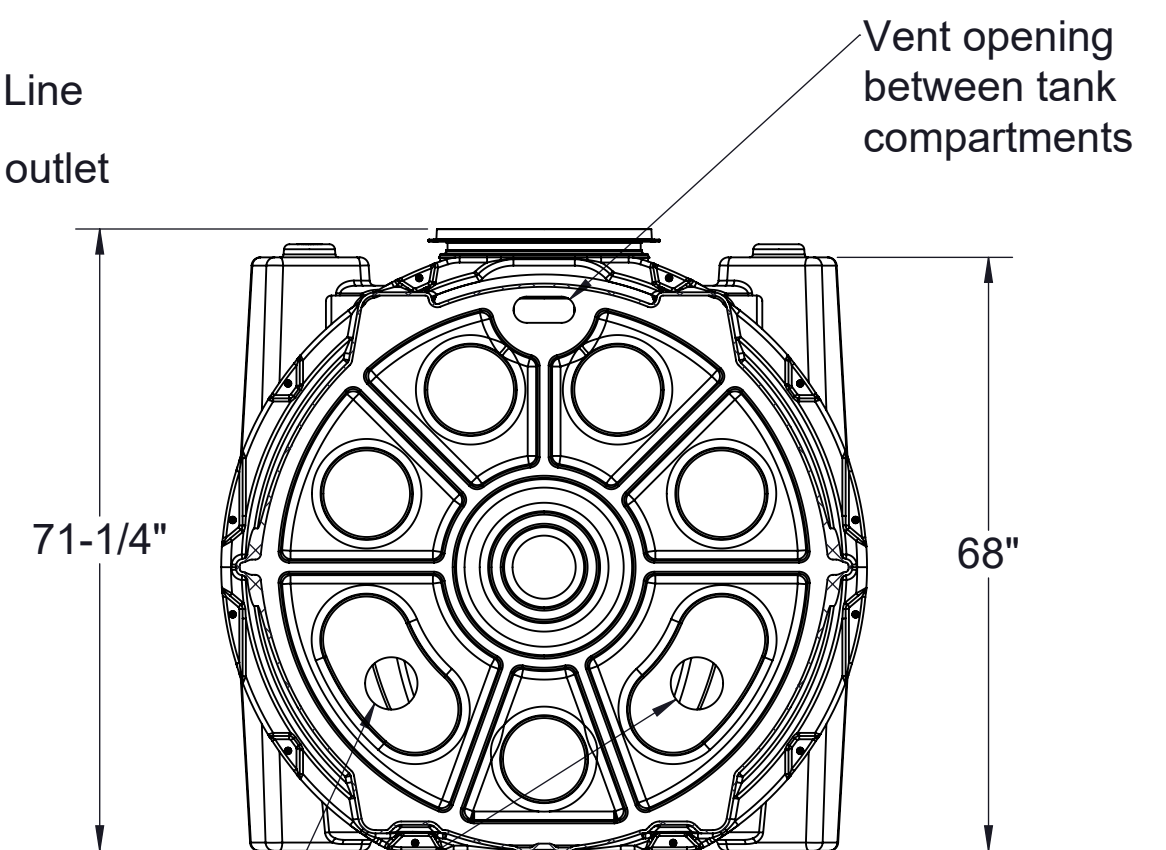

SECTION B-B

SPECIFICATION SHEET

MODEL NUMBER:

PART NUMBER: 4085-001-01

GB-1500

DESCRIPTION:

GB-1500 GREASE INTERCEPTOR 100 GPM / 200 GPM
6" PLAIN INLET/OUTLET, H-20 CAST IRON COVER

PROPRIETARY AND CONFIDENTIAL

THE INFORMATION CONTAINED IN THIS DRAWING IS THE SOLE PROPERTY OF SCHIER PRODUCTS. ANY REPRODUCTION IN PART OR AS A WHOLE WITHOUT THE WRITTEN PERMISSION OF SCHIER PRODUCTS IS PROHIBITED.

DWG BY: T.ASAY

DATE: 12/13/2022

REV: B

ECO: 012623CS

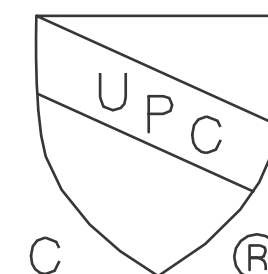
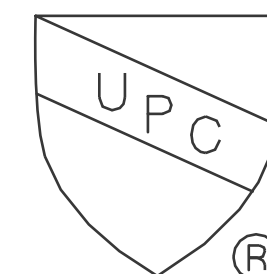

SCHIER

6455 Woodland Dr
Shawnee, KS 66218
Tel: 913-951-3300
Fax: 913-951-3399
schierproducts.com