

Revision A:

• MUZ-GS09/12/15/18/24NA - [U1],
 MUZ-GS09/12/15/18/24NAH - [U1],
 MUZ-GS09/12/15/18/24NAHZ - [U1],
 MUY-GS09/12/15/18/24NA - [U1],
 MUZ-GS30/36NA2 - [U1], MUZ-GS30/36NAH2 - [U1]
 and MUY-GS30/36NA2 - [U1] have been added.
 OBB875 is void.

OUTDOOR UNIT PARTS CATALOG



**No. OBB875
REVISED EDITION-A**

Models

- | | | |
|--------------------|---------------------|--------------------|
| MUZ-GS09NA - [U1] | MUZ-GS18NAH - [U1] | MUY-GS09NA - [U1] |
| MUZ-GS12NA - [U1] | MUZ-GS24NAH - [U1] | MUY-GS12NA - [U1] |
| MUZ-GS15NA - [U1] | MUZ-GS30NAH - [U1] | MUY-GS15NA - [U1] |
| MUZ-GS18NA - [U1] | MUZ-GS36NAH - [U1] | MUY-GS18NA - [U1] |
| MUZ-GS24NA - [U1] | MUZ-GS30NAH2 - [U1] | MUY-GS24NA - [U1] |
| MUZ-GS30NA - [U1] | MUZ-GS36NAH2 - [U1] | MUY-GS30NA - [U1] |
| MUZ-GS36NA - [U1] | MUZ-GS09NAHZ - [U1] | MUY-GS36NA - [U1] |
| MUZ-GS30NA2 - [U1] | MUZ-GS12NAHZ - [U1] | MUY-GS30NA2 - [U1] |
| MUZ-GS36NA2 - [U1] | MUZ-GS15NAHZ - [U1] | MUY-GS36NA2 - [U1] |
| MUZ-GS09NAH - [U1] | MUZ-GS18NAHZ - [U1] | |
| MUZ-GS12NAH - [U1] | MUZ-GS24NAHZ - [U1] | |
| MUZ-GS15NAH - [U1] | | |

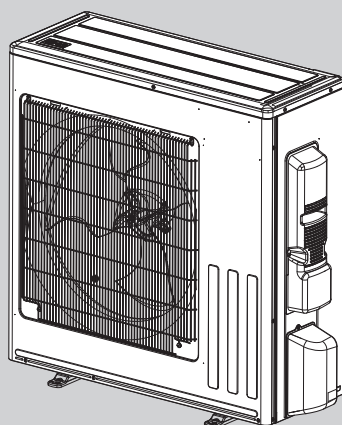

CONTENTS

1. SERVICE PARTS LIST..... 2
2. OPTIONAL PARTS..... 16

SERVICE MANUAL (OBH875)

- MUZ-GS18NA MUZ-GS18NAH MUZ-GS18NAHZ
 MUY-GS18NA MUZ-GS24NA MUZ-GS24NAH
 MUZ-GS24NAHZ MUY-GS24NA
 MUZ-GS30NA MUZ-GS30NAH MUY-GS30NA
 MUZ-GS36NA MUZ-GS36NAH MUY-GS36NA
 MUZ-GS30NA2 MUZ-GS30NAH2 MUY-GS30NA2
 MUZ-GS36NA2 MUZ-GS30NAH2 MUY-GS36NA2

Revision A:

• MUZ-GS09/12/15/18/24NA - [U1], MUZ-GS09/12/15/18/24NAH - [U1], MUZ-GS09/12/15/18/24NAHZ - [U1], MUY-GS09/12/15/18/24NA - [U1], MUZ-GS30/36NA2 - [U1], MUZ-GS30/36NAH2 - [U1] and MUY-GS30/36NA2 - [U1] have been added.

1 SERVICE PARTS LIST

MUZ-GS09NA - [U1] MUZ-GS09NAH - [U1] MUZ-GS09NAHZ - [U1] MUY-GS09NA - [U1]
MUZ-GS12NA - [U1] MUZ-GS12NAH - [U1] MUZ-GS12NAHZ - [U1] MUY-GS12NA - [U1]
MUZ-GS15NA - [U1] MUZ-GS15NAH - [U1] MUZ-GS15NAHZ - [U1] MUY-GS15NA - [U1]

1-1. OUTDOOR UNIT STRUCTURAL PARTS, ELECTRICAL PARTS AND FUNCTIONAL PARTS

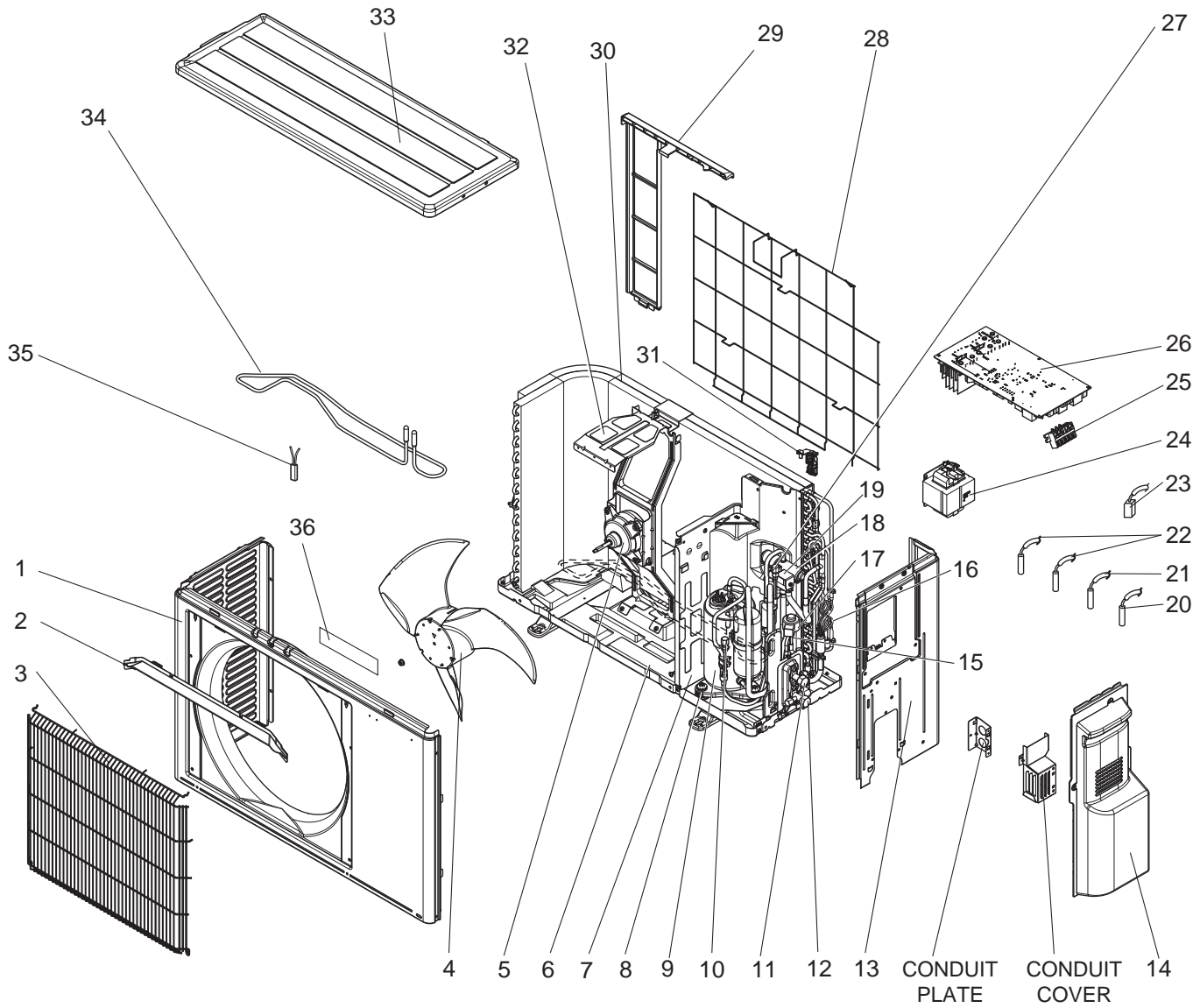

1-1. OUTDOOR UNIT STRUCTURAL PARTS, ELECTRICAL PARTS AND FUNCTIONAL PARTS

1. The part quantity below indicates the required number of pieces per unit.
2. The circled No. indicates that the part is not shown in the figure.

No.	Part No.	Part Name	MUZ-GS09NA - [UT]	MUZ-GS09NAH - [UT]	MUZ-GS09NAHZ - [UT]	MUY-GS09NA - [UT]	MUZ-GS12NA - [UT]	MUZ-GS12NAH - [UT]	MUY-GS12NA - [UT]	MUZ-GS15NA - [UT]	MUZ-GS15NAH - [UT]	MUZ-GS15NAHZ - [UT]	Symbol in Wiring Diagram	Remarks
1	U01 A02 232	CABINET	1	1	1	1	1	1	1	1	1	1		
2	U01 A01 531	ICE GUARD	1	1	1	1	1	1	1	1	1	1		
3	U01 A03 521	GRILLE	1	1	1	1	1	1	1	1	1	1		
4	U01 A01 501	PROPELLER FAN	1	1	1	1	1	1	1	1	1	1		
5	U01 A03 301	OUTDOOR FAN MOTOR	1	1	1	1	1	1	1	1	1	1	MF	RC0J55-□□
6	U01 A02 290	BASE	1			1	1		1	1				
6	U01 A01 290	BASE		1	1			1	1		1	1		
7	U01 A08 293	SEPARATOR	1			1	1		1	1				
7	U01 A09 293	SEPARATOR		1	1			1	1		1	1		
8	U01 A01 506	COMP. RUBBER SET	3	3	3	3	3	3	3	3	3	3		3 RUBBERS/SET
9	U01 A01 900	COMPRESSOR (SNB092FQAMT)	1	1	1	1	1	1	1				MC	SNB092FQAMT
9	U01 A02 900	COMPRESSOR (SNB140FQUMT)						1		1	1	1	MC	SNB140FQUMT
10	U01 A01 641	SERVICE PORT (L)	1	1	1	1	1	1	1	1	1	1		Suction pipe
11	U01 A01 662	STOP VALVE (LIQ)	1	1	1	1	1	1	1	1	1	1		ø1/4 (ø6.35)
12	U01 A01 661	STOP VALVE (GAS)	1	1	1	1	1	1	1					ø3/8 (ø9.52)
12	U01 A02 661	STOP VALVE (GAS)								1	1	1		ø1/2 (ø12.7)
13	U01 A01 233	BACK PANEL	1	1	1	1	1	1	1	1	1	1		
14	U01 A03 245	SERVICE PANEL	1	1	1	1	1	1	1	1	1	1		
15	U01 001 401	EXPANSION VALVE	1	1	1	1	1	1	1	1	1	1		
16	U01 A01 936	CAPILLARY TUBE	4	4	4	4	4	4	4	4	4	4		O.D. 0.118 x I.D. 0.079 x 8-9/32 (ø3.0 x ø2.0 x 210)
17	U01 A01 493	EXPANSION VALVE COIL	1	1	1	1	1	1	1	1	1	1	LEV	
18	U01 A04 961	4-WAY VALVE	1	1	1	1	1	1	1					
18	U01 A06 961	4-WAY VALVE						1		1	1	1		
19	U01 A03 490	R.V. COIL	1	1	1		1	1	1	1	1	1	21S4	
20	U01 A03 308	AMBIENT TEMPERATURE THERMISTOR	1	1		1	1	1	1	1	1	1	RT65	
20	U01 A02 308	AMBIENT TEMPERATURE THERMISTOR			1			1			1		RT65	
21	U01 A02 307	OUTDOOR HEAT EXC. TEMP THERMISTOR	1	1	1	1	1	1	1	1	1	1	RT68	
22	U01 A01 306	THERMISTOR SET	1	1	1		1	1	1	1	1	1	RT61, RT62	DEFROST, DISCHARGE TEMPERATURE
22	U01 A01 309	DISCHARGE TEMPERATURE THERMISTOR				1			1				RT62	
23	U01 A02 381	COMPRESSOR PROTECTOR	1	1	1	1	1	1	1	1	1	1	26C	
24	U01 A01 337	REACTOR	1	1	1	1	1	1	1	1	1	1	L61	
25	U01 A05 374	TERMINAL BLOCK	1	1	1	1	1	1	1	1	1	1	TB	5 P
26	U01 A61 451	INVERTER P.C. BOARD	1	1										
26	U01 A62 451	INVERTER P.C. BOARD				1	1							
26	U01 A63 451	INVERTER P.C. BOARD							1	1				
26	U01 A64 451	INVERTER P.C. BOARD				1								
26	U01 A65 451	INVERTER P.C. BOARD							1					
26	U01 A66 451	INVERTER P.C. BOARD										1		
26	U01 A67 451	INVERTER P.C. BOARD			1									
26	U01 A68 451	INVERTER P.C. BOARD						1						
26	U01 A69 451	INVERTER P.C. BOARD										1		
27	U01 A02 641	SERVICE PORT (H)	1	1	1	1	1	1	1	1	1	1		Discharge pipe
28	U01 A01 525	CONDENSER WIRE NET	1	1	1	1	1	1	1	1	1	1		
29	U01 A01 523	CONDENSER NET	1	1	1	1	1	1	1	1	1	1		
30	U01 A01 630	OUTDOOR HEAT EXCHANGER	1	1	1	1	1	1	1	1	1	1		
31	U01 A02 079	THERMO HOLDER	1	1		1	1	1	1	1	1	1		for RT65
31	U01 A01 079	THERMO HOLDER			1			1			1			for RT65
32	U01 A01 515	MOTOR SUPPORT	1	1	1	1	1	1	1	1	1	1		
33	U01 A01 297	TOP PANEL	1	1	1	1	1	1	1	1	1	1		
34	U01 A03 526	DEFROST HEATER		1	1			1	1		1	1	H	Includes lead wire
35	U01 A01 381	HEATER PROTECTOR		1	1			1	1		1	1	26H	
36	U01 M01 987	LOGO LABEL	1	1	1	1	1	1	1	1	1	1		
③7	U01 A02 936	CAPILLARY TUBE	1	1	1	1	1	1	1	1	1	1		O.D. 0.157 x I.D. 0.094 x 9-7/16 (ø4.0 x ø2.4 x 240)

MUZ-GS18NA - U1

MUZ-GS18NAH - U1

MUZ-GS18NAHZ - U1

MUY-GS18NA - U1

MUZ-GS24NA - U1

MUZ-GS24NAH - U1

MUZ-GS24NAHZ - U1

MUY-GS24NA - U1

1-2. OUTDOOR UNIT STRUCTURAL PARTS

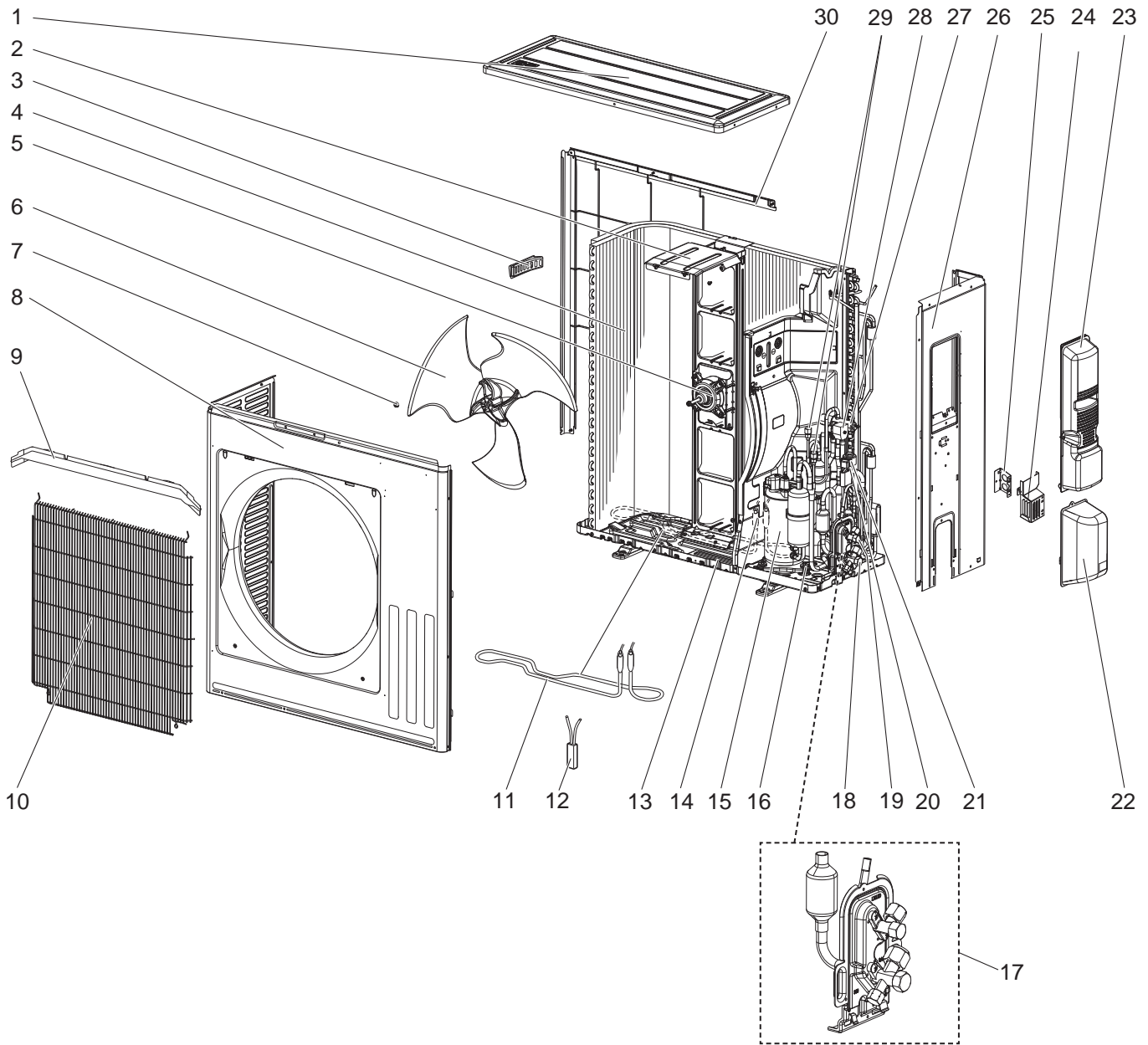

1-2. OUTDOOR UNIT STRUCTURAL PARTS

1. The part quantity below indicates the required number of pieces per unit.
2. The circled No. indicates that the part is not shown in the figure.

No.	Part No.	Part Name	MUZ-GS18NA - [UT]	MUZ-GS18NAH - [UT]	MUZ-GS18NAHZ - [UT]	MUY-GS18NA - [UT]	MUZ-GS24NA - [UT]	MUZ-GS24NAH - [UT]	MUZ-GS24NAHZ - [UT]	MUY-GS24NA - [UT]	Symbol in Wiring Diagram	Remarks [Drawing No.]
1	E22 L87 297	TOP PANEL	1	1	1	1	1	1	1	1		
2	E22 59N 515	MOTOR SUPPORT	1	1		1	1	1		1		
2	E22 33N 515	MOTOR SUPPORT			1					1		
3	E22 817 009	HANDLE	1	1	1	1	1	1	1	1		
4	E22 88R 630	OUTDOOR HEAT EXCHANGER	1	1								
4	E22 51T 630	OUTDOOR HEAT EXCHANGER				1						
4	E22 33N 630	OUTDOOR HEAT EXCHANGER			1							
4	E22 89R 630	OUTDOOR HEAT EXCHANGER					1	1	1			
4	E22 91R 630	OUTDOOR HEAT EXCHANGER								1		
5	E27 Y92 301	OUTDOOR FAN MOTOR	1	1		1					MF	RC0J77-□□
5	E22 91F 301	OUTDOOR FAN MOTOR			1		1	1	1	1	MF	RC0J77-□□
6	E22 91F 501	PROPELLER FAN	1	1	1	1	1	1	1	1		
7	E27 L05 508	PROPELLER FAN NUT	1	1	1	1	1	1	1	1		
8	E27 Y92 232	CABINET	1	1		1						
8	E22 91F 232	CABINET			1		1	1	1	1		
9	E22 33N 531	ICE GUARD	1	1	1		1	1	1			
10	E22 91F 521	GRILLE	1	1	1	1	1	1	1	1		
11	E22 39F 526	DEFROST HEATER		1	1			1	1		H	
12	E22 J52 381	HEATER PROTECTOR		1	1			1	1		26H	
13	E22 91F 290	BASE	1			1	1			1		
13	E22 57N 290	BASE		1	1			1	1			
14	E22 50T 293	SEPARATOR	1			1						
14	E22 52T 293	SEPARATOR		1								
14	E22 57N 293	SEPARATOR			1			1	1			
14	E22 33N 293	SEPARATOR				1				1		
15	E22 50T 900	COMPRESSOR	1	1		1					MC	SNB130FQBMT
15	E22 89R 900	COMPRESSOR			1		1	1	1	1	MC	SNB172FQKMT
16	E22 C34 506	COMPRESSOR RUBBER SET	3	3	3	3	3	3	3	3		3 RUBBERS/SET
17	E22 33N 663	STOP VALVE ASSY	1	1	1	1						Includes STOP VALVES (LIQ ø1/4 (ø6.35), GAS ø1/2 (ø12.7)), muffler
17	E22 89R 663	STOP VALVE ASSY					1	1	1	1		Includes STOP VALVES (LIQ ø1/4 (ø6.35), GAS ø5/8 (ø15.88)), muffler
18	E22 33N 661	STOP VALVE (GAS)	1	1	1	1						ø1/2 (ø12.7)
18	E22 89R 661	STOP VALVE (GAS)					1	1	1	1		ø5/8 (ø15.88)
19	E22 33N 662	STOP VALVE (LIQUID)	1	1	1	1						ø1/4 (ø6.35)
19	E22 89R 662	STOP VALVE (LIQUID)					1	1	1	1		ø1/4 (ø6.35)
20	E22 50T 645	EXPANSION VALVE ASSY	1	1		1						Includes LEV body, capillary tube
20	E22 33N 645	EXPANSION VALVE ASSY			1							O.D. 0.157 x I.D. 0.094 x 3-15/16
20	E22 89R 645	EXPANSION VALVE ASSY					1	1	1	1		(ø4.0 x ø2.4 x 100), muffler
21	E22 55J 493	EXPANSION VALVE COIL	1	1	1	1	1	1	1	1	LEV	
22	E22 F28 650	VALVE COVER	1	1	1	1	1	1	1	1		
23	E22 91F 245	SERVICE PANEL	1	1	1	1	1	1	1	1		
24	E22 43F 979	CONDUIT COVER	1	1	1	1	1	1	1	1		
25	E22 29F 978	CONDUIT PLATE	1	1	1	1	1	1	1	1		
26	E22 33N 233	BACK PANEL	1	1	1	1	1	1	1	1		
27	E22 J61 961	4-WAY VALVE	1	1	1	1	1	1	1	1		
28	E22 33N 490	R.V. COIL	1	1	1		1	1	1	1	21S4	
29	E22 E79 641	SERVICE PORT (H, L)	2	2	2	2	2	2	2	2		
30	E22 L87 523	CONDENSER NET	1	1	1	1	1	1	1	1		
(31)	—	BRAND LABEL	1	1	1	1	1	1	1	1		[DK79G041H02]
(32)	—	H2I LABEL			1					1		[BT79C374H03]
(33)	—	PB SUPPORT	1	1		1						[DY25A460G16]
(33)	—	PB SUPPORT			1		1	1	1	1		[DY00B954G02]
(34)	—	PB COVER	1	1		1						[DY00B947G01]
(34)	—	PB COVER			1		1	1	1	1		[DY00B955G01]
(35)	—	LEAD ASSY COMP	1	1		1	1	1	1	1		[DY78C464G17]
(35)	—	LEAD ASSY COMP			1					1		[DY78C464G18]
(36)	—	COMP FELT (TOP)	1	1	1	1	1	1	1	1		[SQ33N879H05]
(37)	—	COMP FELT (BODY)	1	1	1	1	1	1	1	1		[JQ33Y367H01]

MUZ-GS18NA - U1 MUZ-GS18NAH - U1 MUZ-GS18NAHZ - U1 MUY-GS18NA - U1
 MUZ-GS24NA - U1 MUZ-GS24NAH - U1 MUZ-GS24NAHZ - U1 MUY-GS24NA - U1

1-3. OUTDOOR UNIT ELECTRICAL PARTS

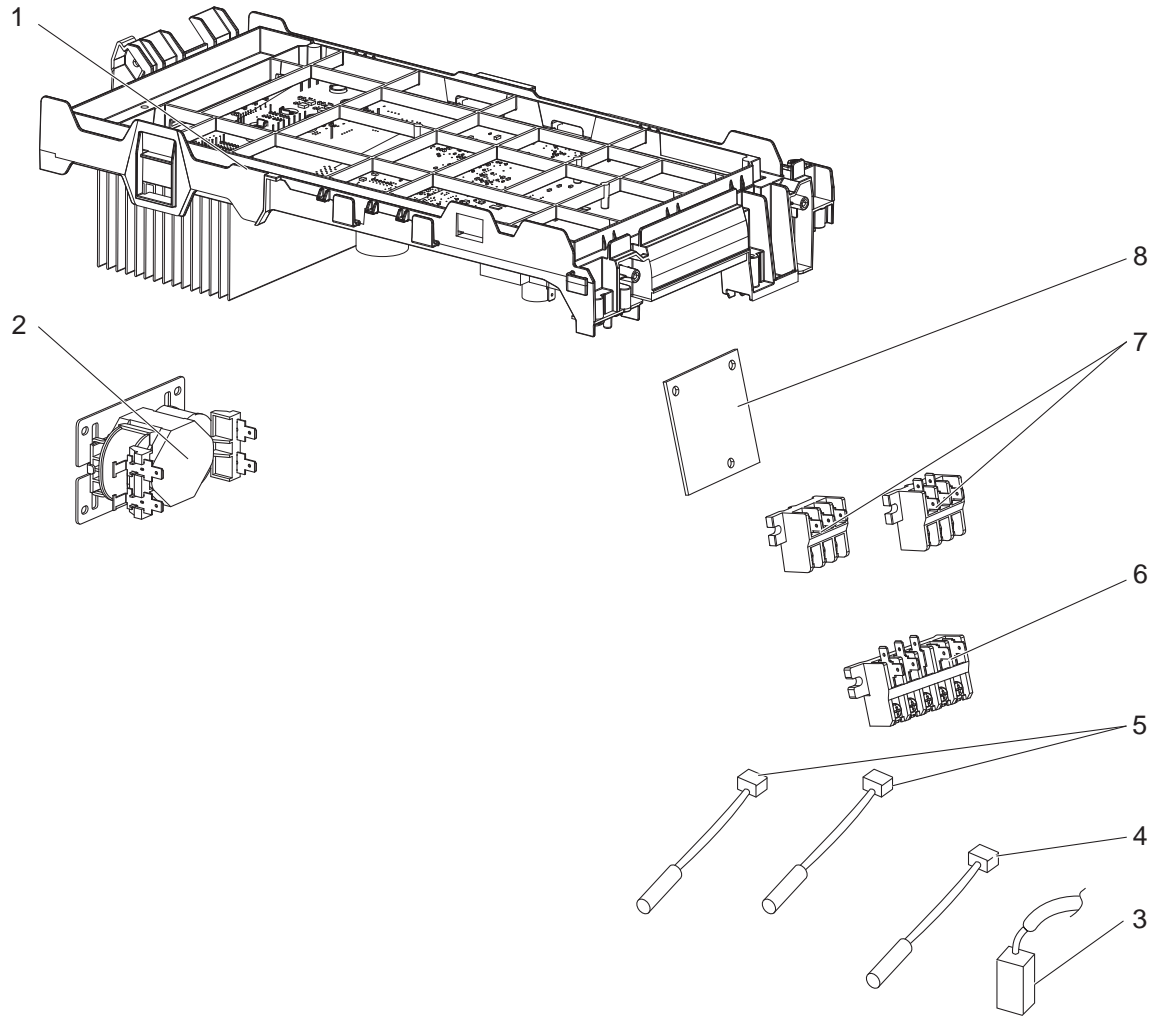

1-3. OUTDOOR UNIT ELECTRICAL PARTS

1. The part quantity below indicates the required number of pieces per unit.

No.	Part No.	Part Name	MUZ-GS18NA - [UT]	MUZ-GS18NAH - [UT]	MUZ-GS18NAHZ - [UT]	MUY-GS18NA - [UT]	MUZ-GS24NA - [UT]	MUZ-GS24NAH - [UT]	MUZ-GS24NAHZ - [UT]	MUY-GS24NA - [UT]	Symbol in Wiring Diagram	Remarks
1	E22 50T 451	INVERTER P.C. BOARD	1	1								Includes heat sink and RT64
1	E22 51T 451	INVERTER P.C. BOARD				1						Includes heat sink and RT64
1	E22 88R 451	INVERTER P.C. BOARD			1							Includes heat sink and RT64
1	E22 90R 451	INVERTER P.C. BOARD					1	1				Includes heat sink and RT64
1	E22 91R 451	INVERTER P.C. BOARD								1		Includes heat sink and RT64
1	E22 89R 451	INVERTER P.C. BOARD							1			Includes heat sink and RT64
2	E22 63V 337	REACTOR	1	1		1					L61	
2	E22 R84 337	REACTOR			1		1	1	1	1	L	
3	E22 42X 381	COMPRESSOR PROTECTOR	1	1	1	1	1	1	1	1	26C	
4	E22 29F 309	AMBIENT TEMPERATURE THERMISTOR	1	1		1	1	1		1	RT65	
4	E22 38F 309	AMBIENT TEMPERATURE THERMISTOR			1				1		RT65	
5	E22 G16 308	THERMISTOR SET	1	1							RT61,RT62	Combined type
5	E22 N94 308	DISCHARGE TEMPERATURE THERMISTOR				1					RT62	
5	E22 F28 308	THERMISTOR SET			1		1	1	1		RT61,RT62, RT68	Combined type
5	E22 F33 308	THERMISTOR SET								1	RT62,RT68	Combined type
6	E22 50T 374	TERMINAL BLOCK	1	1		1					TB1	5 P
7	E22 88R 374	TERMINAL BLOCK			1		1	1	1	1	TB1	3 P
7	E22 89R 374	TERMINAL BLOCK			1		1	1	1	1	TB2	3 P
8	E22 88R 382				1		1	1	1	1	F65, F66	T6.3AL250V

MUZ-GS30NA - U1 MUZ-GS30NAH - U1 MUY-GS30NA - U1
 MUZ-GS36NA - U1 MUZ-GS36NAH - U1 MUY-GS36NA - U1

1-4. OUTDOOR UNIT STRUCTURAL PARTS

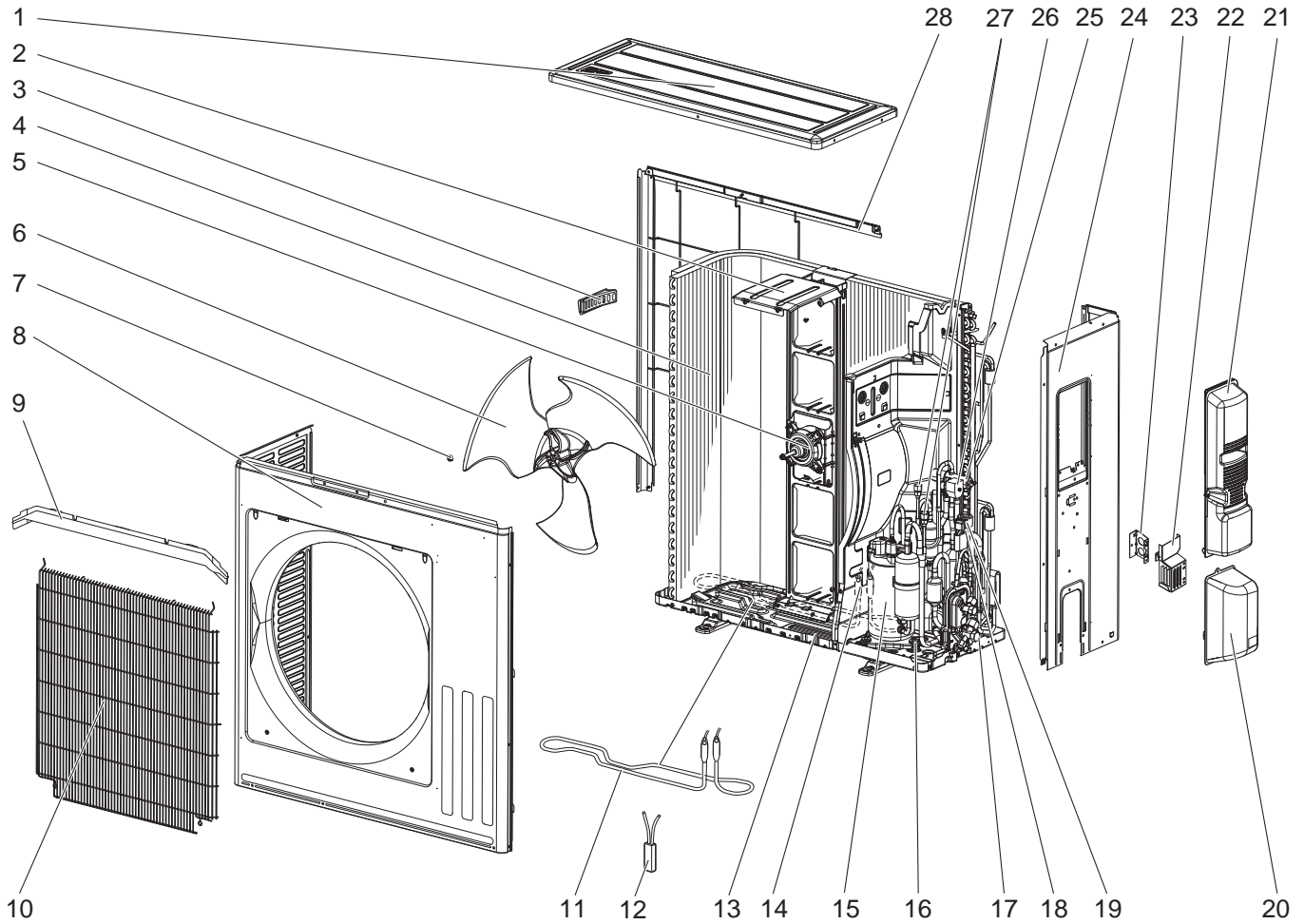

1-4. OUTDOOR UNIT STRUCTURAL PARTS

1. The part quantity below indicates the required number of pieces per unit.

No.	Part No.	Part Name							Symbol in Wiring Diagram	Remarks [Drawing No.]
			MUZ-GS30NA - U1	MUZ-GS30NAH - U1	MUY-GS30NA - U1	MUZ-GS36NA - U1	MUZ-GS36NAH - U1	MUY-GS36NA - U1		
1	E22 L87 297	TOP PANEL	1	1	1	1	1	1		
2	E22 59N 515	MOTOR SUPPORT	1	1	1	1	1	1		
3	E22 817 009	HANDLE	1	1	1	1	1	1		
4	E22 59N 630	OUTDOOR HEAT EXCHANGER	1	1		1	1			Includes capillary tubes O.D. 0.157 x I.D. 0.094 x 3-15/16 (ø4.0 x ø2.4 x 100) (2PCS)
4	E22 47N 630	OUTDOOR HEAT EXCHANGER			1			1		
5	E22 91F 301	OUTDOOR FAN MOTOR	1	1	1	1	1	1	MF	RC0J50-□□
6	E22 91F 501	PROPELLER FAN	1	1	1	1	1	1		
7	E27 L05 508	PROPELLER FAN NUT	1	1	1	1	1	1		
8	E22 91F 232	CABINET	1	1	1	1	1	1		
9	E22 33N 531	ICE GUARD	1	1		1	1			
10	E22 91F 521	GRILLE	1	1	1	1	1	1		
11	E22 39F 526	DEFROST HEATER		1			1		H	Includes 26H
12	E22 J52 381	HEATER PROTECTOR		1			1		26H	
13	E22 91F 290	BASE	1		1	1		1		
13	E22 57N 290	BASE		1			1			
14	E22 33N 293	SEPARATOR	1		1	1		1		
14	E22 57N 293	SEPARATOR		1			1			
15	E22 59N 900	COMPRESSOR	1	1	1	1	1	1	MC	SNB220FQAM1T
16	E22 C34 506	COMPRESSOR RUBBER SET	3	3	3	3	3	3		3 RUBBERS/SET
17	E22 59N 663	STOP VALVE ASSEMBLY	1	1	1	1	1	1		Includes STOP VALVES (LIQ ø1/4 (ø6.35), GAS ø5/8 (ø15.88))
18	E22 59N 645	EXPANSION VALVE ASSEMBLY	1	1	1	1	1	1		Includes LEV body, capillary tube O.D. 0.157 x I.D. 0.094 x 3-15/16 (ø4.0 x ø2.4 x 100), muffler
19	E22 55J 493	EXPANSION VALVE COIL	1	1	1	1	1	1	LEV	
20	E22 F28 650	VALVE COVER	1	1	1	1	1	1		
21	E22 91F 245	SERVICE PANEL	1	1	1	1	1	1		
22	E22 43F 979	CONDUIT COVER	1	1	1	1	1	1		
23	E22 29F 978	CONDUIT PLATE	1	1	1	1	1	1		
24	E22 33N 233	BACK PANEL	1	1	1	1	1	1		
25	E22 J61 961	4-WAY VALVE	1	1	1	1	1	1		
26	E22 33N 490	R.V. COIL	1	1		1	1		21S4	
27	E22 E79 641	SERVICE PORT	2	2	2	2	2	2		
28	E22 L87 523	CONDENSER NET	1	1	1	1	1	1		

MUZ-GS30NA - U1 MUZ-GS30NAH - U1 MUY-GS30NA - U1
MUZ-GS36NA - U1 MUZ-GS36NAH - U1 MUY-GS36NA - U1

1-5. OUTDOOR UNIT ELECTRICAL PARTS

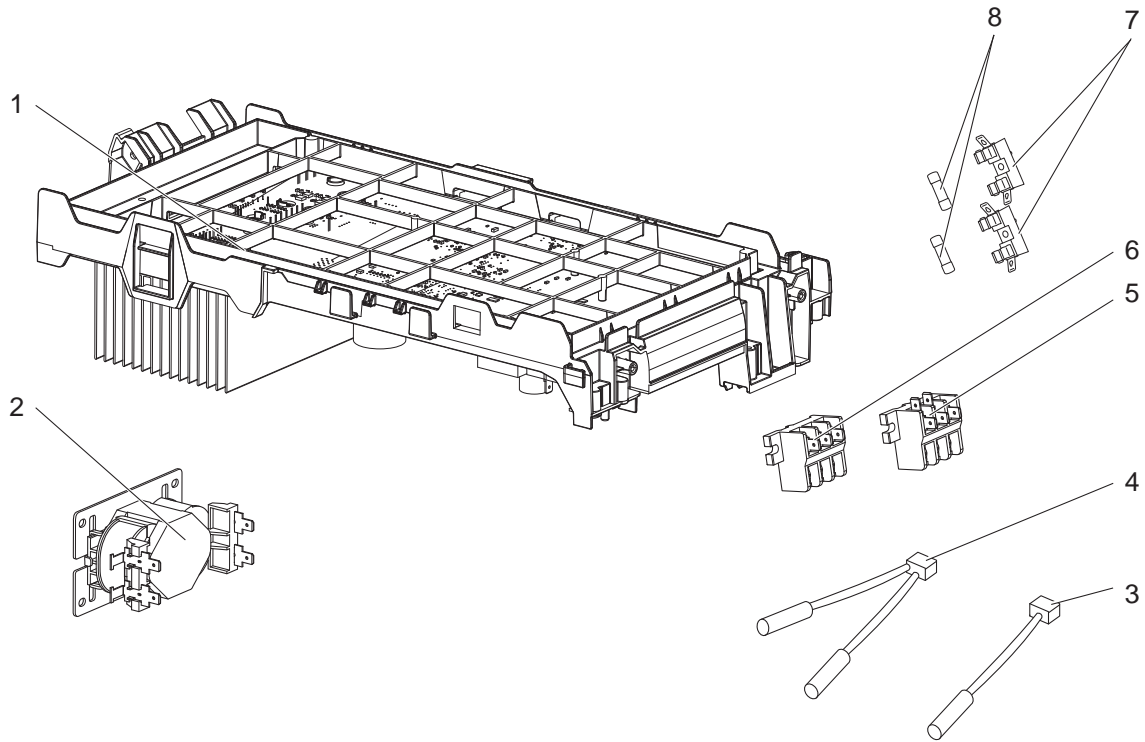

1-5. OUTDOOR UNIT ELECTRICAL PARTS

1. The part quantity below indicates the required number of pieces per unit.

No.	Part No.	Part Name	MUZ-GS30NA - <input type="checkbox"/> U1	MUZ-GS30NAH - <input type="checkbox"/> U1	MUY-GS30NA - <input type="checkbox"/> U1	MUZ-GS36NA - <input type="checkbox"/> U1	MUZ-GS36NAH - <input type="checkbox"/> U1	MUY-GS36NA - <input type="checkbox"/> U1	Symbol in Wiring Diagram	Remarks
1	E22 45N 451	INVERTER P.C. BOARD	1	1						Includes heat sink and RT64
1	E22 47N 451	INVERTER P.C. BOARD			1					Includes heat sink and RT64
1	E22 46N 451	INVERTER P.C. BOARD				1	1			Includes heat sink and RT64
1	E22 48N 451	INVERTER P.C. BOARD						1		Includes heat sink and RT64
2	E22 R84 337	REACTOR	1	1	1	1	1	1	L	
3	E22 29F 309	AMBIENT THERMISTOR ASSEMBLY	1	1	1	1	1	1	RT65	
4	E22 F28 308	THERMISTOR SET	1	1		1	1		RT61, RT62, RT68	DEFROST THERMISTOR (RT61) DISCHARGE TEMPERATURE (RT62) OUTDOOR HEAT EXCHANGER TEMPERATURE (RT68)
4	E22 F33 308	THERMISTOR SET			1			1	RT62, RT68	DISCHARGE TEMPERATURE (RT62) OUTDOOR HEAT EXCHANGER TEMPERATURE (RT68)
5	E22 L87 374	TERMINAL BLOCK	1	1	1	1	1	1	TB1	3 P
6	E22 T16 374	TERMINAL BLOCK	1	1	1	1	1	1	TB2	3 P
7	E27 001 241	FUSE HOLDER	2	2	2	2	2	2		
8	E27 250 382	FUSE	2	2	2	2	2	2	F65, F66	T6.3AL 250 V AC

MUZ-GS30NA2 - U1 MUZ-GS30NAH2 - U1 MUY-GS30NA2 - U1
MUZ-GS36NA2 - U1 MUZ-GS36NAH2 - U1 MUY-GS36NA2 - U1

1-6. OUTDOOR UNIT STRUCTURAL PARTS

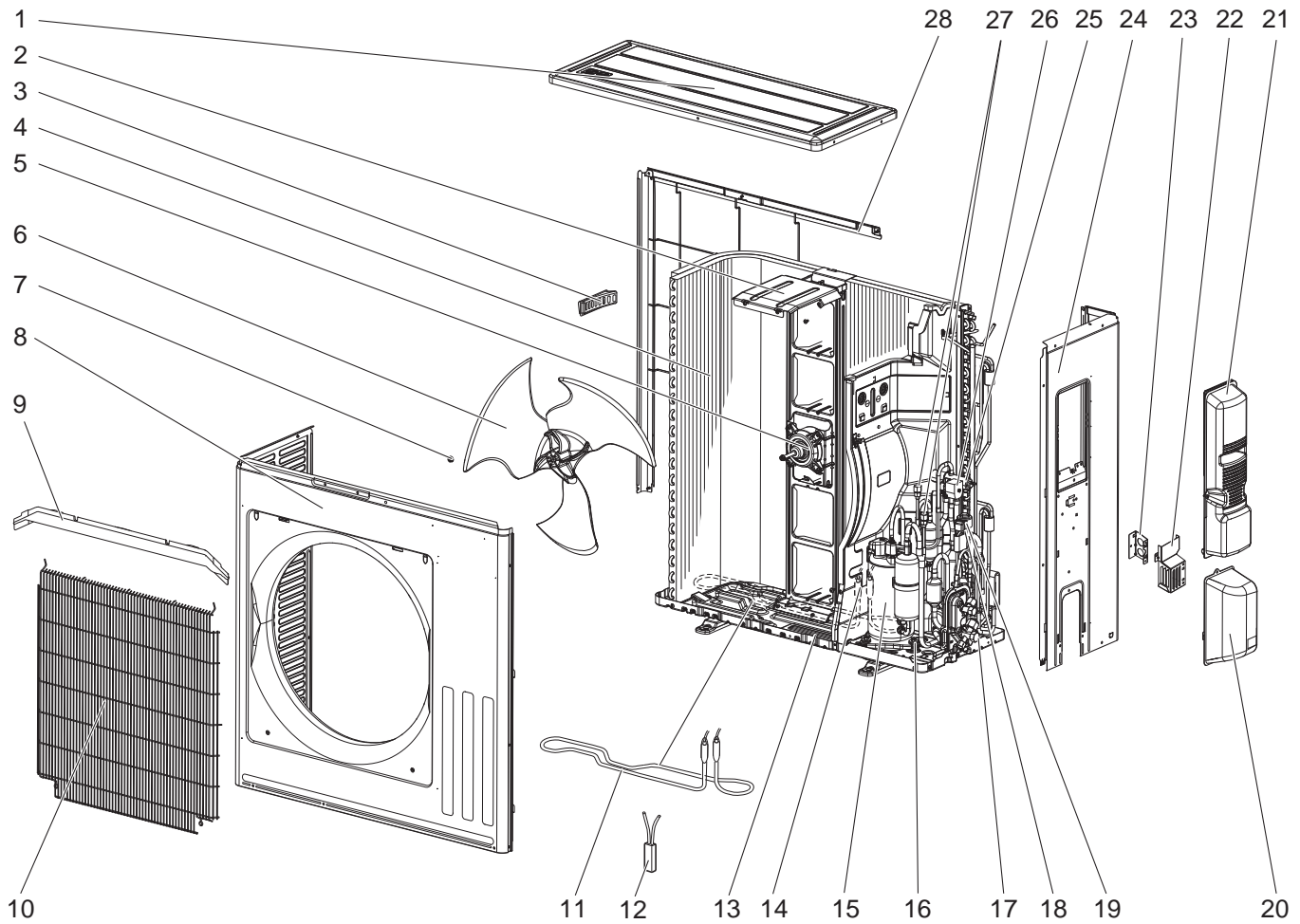

1-6. OUTDOOR UNIT STRUCTURAL PARTS

1. The part quantity below indicates the required number of pieces per unit.

No.	Part No.	Part Name	MUZ-GS30NA2 - UT	MUZ-GS30NAH2 - UT	MUY-GS30NA2 - UT	MUZ-GS36NA2 - UT	MUZ-GS36NAH2 - UT	MUY-GS36NA2 - UT	Symbol in Wiring Diagram	Remarks [Drawing No.]
1	E22 L87 297	TOP PANEL	1	1	1	1	1	1		
2	E22 59N 515	MOTOR SUPPORT	1	1		1	1			
2	E22 91F 515	MOTOR SUPPORT			1			1		
3	E22 817 009	HANDLE	1	1	1	1	1	1		
4	E22 52V 630	OUTDOOR HEAT EXCHANGER	1	1		1	1			
4	E22 55J 630	OUTDOOR HEAT EXCHANGER			1			1		
5	E22 91F 301	OUTDOOR FAN MOTOR	1	1	1	1	1	1	MF	RC0J50-□□
6	E22 91F 501	PROPELLER FAN	1	1	1	1	1	1		
7	E27 L05 508	PROPELLER FAN NUT	1	1	1	1	1	1		
8	E22 52V 232	CABINET	1	1		1	1			
8	E22 54V 232	CABINET			1			1		
9	E22 33N 531	ICE GUARD	1	1		1	1			
10	E22 91F 521	GRILLE	1	1	1	1	1	1		
11	E22 39F 526	DEFROST HEATER		1			1		H	Includes 26H
12	E22 J52 381	HEATER PROTECTOR		1			1		26H	
13	E22 52V 290	BASE	1			1				
13	E22 57N 290	BASE		1			1			
13	E22 91F 290	BASE			1			1		
14	E22 33N 293	SEPARATOR	1			1				
14	E22 57N 293	SEPARATOR		1			1			
14	E22 91F 293	SEPARATOR			1			1		
15	E22 85V 900	COMPRESSOR	1	1	1	1	1	1	MC	SNB220FQAM1T
16	E22 C34 506	COMPRESSOR RUBBER SET	3	3	3	3	3	3		3 RUBBERS/SET
17	E22 59N 663	STOP VALVE ASSEMBLY	1	1	1	1	1	1		Includes STOP VALVES (LIQ ϕ 1/4 (ϕ 6.35), GAS ϕ 5/8 (ϕ 15.88))
18	E22 59N 645	EXPANSION VALVE ASSEMBLY	1	1		1	1			Includes LEV body, capillary tube O.D. 0.157 x I.D. 0.094 x 3-15/16 (ϕ 4.0 x ϕ 2.4 x 100), muffler
18	E22 54V 645	EXPANSION VALVE ASSEMBLY			1			1		Includes LEV body, capillary tube O.D. 0.157 x I.D. 0.094 x 3-15/16 (ϕ 4.0 x ϕ 2.4 x 100), muffler
19	E22 55J 493	EXPANSION VALVE COIL	1	1	1	1	1	1	LEV	
20	E22 F28 650	VALVE COVER	1	1	1	1	1	1		
21	E22 91F 245	SERVICE PANEL	1	1	1	1	1	1		
22	E22 43F 979	CONDUIT COVER	1	1	1	1	1	1		
23	E22 29F 978	CONDUIT PLATE	1	1	1	1	1	1		
24	E22 33N 233	BACK PANEL	1	1		1	1			
24	E22 54V 233	BACK PANEL			1			1		
25	E22 J61 961	4-WAY VALVE	1	1		1	1			
26	E22 33N 490	R.V. COIL	1	1		1	1		21S4	
27	E22 E79 641	SERVICE PORT	1	1	2	1	1	2		
27	E22 L85 641	SERVICE PORT	1	1		1	1			
28	E22 L87 523	CONDENSER NET	1	1	1	1	1	1		
29	E22 89R 661	STOP VALVE(GAS)	1	1	1	1	1	1		Φ 5/8(Φ 15.88)
30	E22 52V 662	STOP VALVE(LIQUID)	1	1	1	1	1	1		Φ 1/4 (Φ 6.35)

MUZ-GS30NA2 - U1 MUZ-GS30NAH2 - U1 MUY-GS30NA2 - U1
MUZ-GS36NA2 - U1 MUZ-GS36NAH2 - U1 MUY-GS36NA2 - U1

1-7. OUTDOOR UNIT ELECTRICAL PARTS

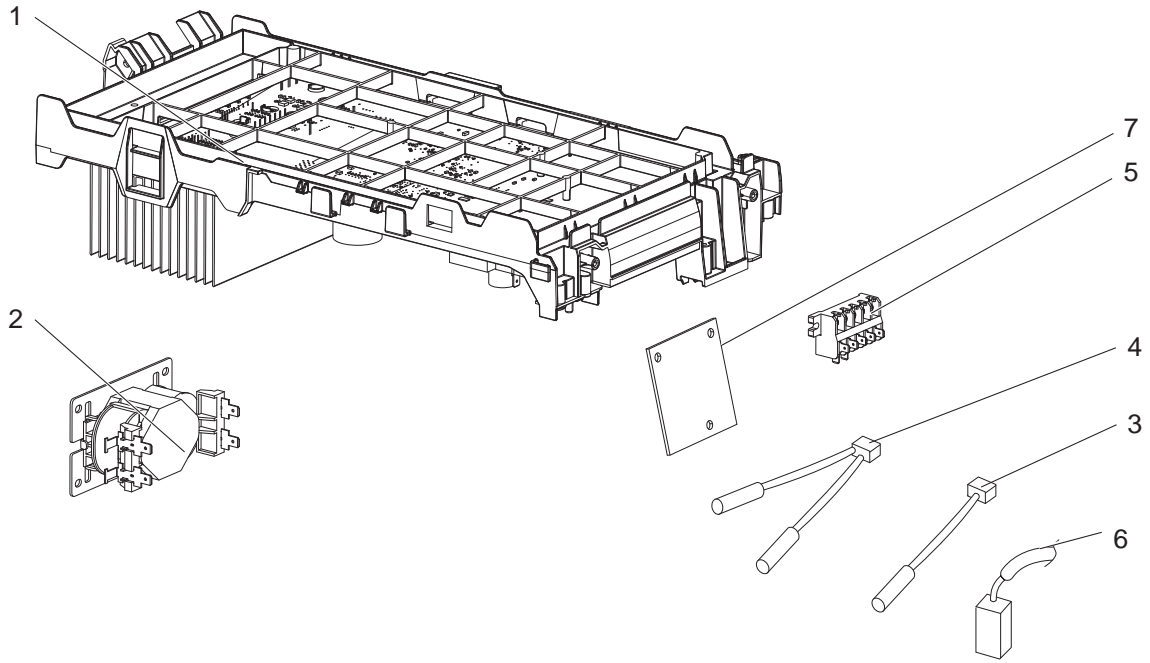

1-7. OUTDOOR UNIT ELECTRICAL PARTS

1. The part quantity below indicates the required number of pieces per unit.

No.	Part No.	Part Name	MUZ-GS30NA2 - <input type="checkbox"/> UT	MUZ-GS30NAH2 - <input type="checkbox"/> UT	MUY-GS30NA2 - <input type="checkbox"/> UT	MUZ-GS36NA2 - <input type="checkbox"/> UT	MUZ-GS36NAH2 - <input type="checkbox"/> UT	MUY-GS36NA2 - <input type="checkbox"/> UT	Symbol in Wiring Diagram	Remarks
1	E22 52V 451	INVERTER P.C. BOARD	1	1						Includes heat sink and RT64
1	E22 53V 451	INVERTER P.C. BOARD				1	1			Includes heat sink and RT64
1	E22 54V 451	INVERTER P.C. BOARD			1					Includes heat sink and RT64
1	E22 55V 451	INVERTER P.C. BOARD						1		Includes heat sink and RT64
2	E22 R84 337	REACTOR	1	1	1	1	1	1	L	
3	E22 29F 309	AMBIENT THERMISTOR ASSEMBLY	1	1	1	1	1	1	RT65	
4	E22 F28 308	THERMISTOR SET	1	1		1	1		RT61, RT62, RT68	DEFROST THERMISTOR (RT61) DISCHARGE TEMPERATURE (RT62) OUTDOOR HEAT EXCHANGER TEMPERATURE (RT68)
4	E22 25W 307	THERMISTOR SET			1			1	RT62, RT68	DISCHARGE TEMPERATURE (RT62) OUTDOOR HEAT EXCHANGER TEMPERATURE (RT68)
5	E22 52V 374	TERMINAL BLOCK	1	1	1	1	1	1	TB1	5 P
6	E22 42X 381	COMPRESSOR PROTECTOR	1	1	1	1	1	1	26C	
7	E22 88R 382	FUSE P.C. BOARD	1	1	1	1	1	1	F65, F66	T6.3AL250V

2

OPTIONAL PARTS

2-1. DEFROST HEATER

Model	Parts No.
MUZ-GS09NA MUZ-GS12NA MUZ-GS15NA	MAC-640BH - U

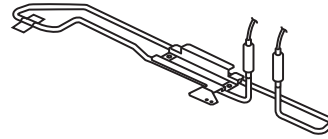

Components

① Defrost heater	1	④ Cable tie	1
② Aluminum tape	1	⑤ Self drilling screw	2
③ Heater support	1	⑥ Insulation	1

Model	Parts No.
MUZ-GS18NA MUZ-GS24NA MUZ-GS30NA MUZ-GS36NA MUZ-GS30NA2 MUZ-GS36NA2	MAC-642BH - U1

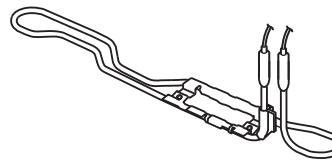

Components

① Defrost heater	1	④ Cable clamp	1
② Heater support	1	⑤ Self drilling screw	2
③ Cable tie	1	⑥ Wiring diagram	1

Note: Refer to the installation manual for the installation.

2-2. DRAIN SOCKET

Model	Parts No.
MUZ-GS09NA MUZ-GS12NA MUZ-GS15NA MUZ-GS18NA MUZ-GS24NA MUZ-GS30NA MUZ-GS36NA MUZ-GS30NA2 MUZ-GS36NA2	MAC-860DS

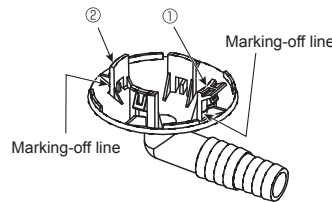

Installing a Drain Socket

For Φ 1-5/8 (Φ 42) hole

Put the tab ① in the hole first, and then the tab ②.

MITSUBISHI ELECTRIC CORPORATION

HEAD OFFICE: TOKYO BUILDING, 2-7-3, MARUNOUCHI, CHIYODA-KU, TOKYO 100-8310, JAPAN

© Copyright 2021 MITSUBISHI ELECTRIC CORPORATION

Issued: Oct. 2022 No. OBB875 REVISED EDITION-A

Published: Jan. 2021. No. OBH875

Made in Japan

Specifications are subject to change without notice.