

# 80G2E

## PRODUCT SPECIFICATIONS

## 80% TWO-STAGE CONSTANT TORQUE GAS FURNACES

FORM NO. 80G2E-100 (04/2022)



### CONTROLS

- Two stage gas valve
- Integrated ignition and fan control
- Self diagnostics saving last 10 fault codes regardless of power interruption
- Hot surface ignition system uses silicon nitride ignitor
- Control features 120 volt electronic air cleaner and humidifier terminals
- Control circuit is fuse protected
- Color coded control wiring
- Compatible with single or two stage thermostats for heating. Two stage thermostat is recommended when installed with two stage cooling unit.

### VENTING

- 2-speed induced draft motor with stainless steel shaft, steel ball bearings, and fan cooled for long life

### INSTALLATION FEATURES

- Left or right gas and electric entry
- Zero step horizontal conversion
- Removable floor base (upflow/horizontal units) for bottom return air

### WARRANTY

10 year limited parts warranty / lifetime heat exchanger warranty available. See limited warranty document for details.

#### California Only

*If installed in South Coast Air Quality Management District (SCAQMD) only: This furnace is not eligible for the Clean Air Furnace Rebate Program: [www.CleanAirFurnaceRebate.com](http://www.CleanAirFurnaceRebate.com).*

*This furnace does not meet the SCAQMD Rule 1111 NOx emission limit (14 ng/J).*

*If installed in San Joaquin Valley Air Pollution Control District (SJVAPCD) only: This furnace does not meet the SJVAPCD Rule 4905 NOx emission limit (14 ng/J).*

### CONFIGURATIONS

- Upflow / Horizontal
- Downflow

### HEAT EXCHANGER DESIGN

- Aluminized steel primary heat exchanger with crimped non-welded construction

### BURNERS

- Aluminized steel in shot burners for smooth ignition

### CABINET CONSTRUCTION

- Compact 33" height
- Standardized widths for easy coil fit
- Heat exchanger compartment is insulated to increase efficiency and reduce sound levels
- Baked on prepainted steel cabinet finish

### CONSTANT TORQUE ECM

- Efficient blower motor
- Easily removable slide-out blower design
- Dynamically balanced blower wheel with resilient motor mounts for smooth and quiet operation



**MODEL NUMBER GUIDE**

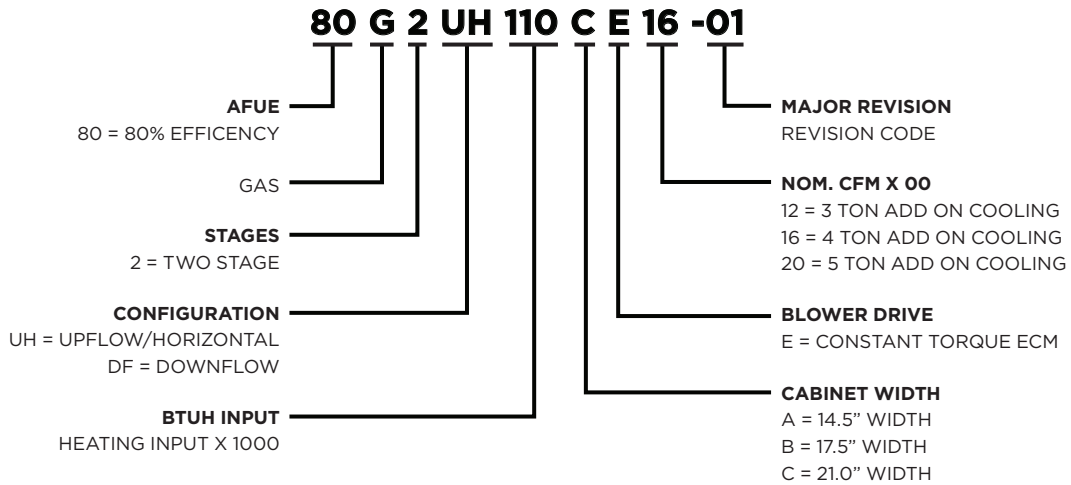

**PHYSICAL AND ELECTRICAL DATA**

	Model	High Fire		Low Fire		AFUE (ICUS)	Nom. Cooling Capacity (tons)	Gas Inlet (in.)	Volts/Hz/Phase	Max. Overcurrent Protection	Nominal F.L.A.	Trans. (V.A.)	Motor Output (hp)	Approx. Weight (lbs.)
		Input (Btuh)	Output (Btuh)	Input (Btuh)	Output (Btuh)									
UPFLOW / HORIZONTAL	80G2UH045AE12	44,000	35,000	29,000	23,000	80.0	3	1/2	120-60-1	15	6.1	40	1/2	111
	80G2UH070AE12 80G2UH070AE12L	66,000	54,000	43,000	35,000	80.0	3	1/2	120-60-1	15	6.1	40	1/2	121
	80G2UH090BE12	88,000	71,000	57,000	47,000	80.0	3	1/2	120-60-1	15	6.1	40	1/2	136
	80G2UH090BE16 80G2UH090BE16L	88,000	72,000	57,000	46,000	80.0	4	1/2	120-60-1	15	8.2	40	3/4	140
	80G2UH110CE16	110,000	89,000	72,000	58,000	80.0	4	1/2	120-60-1	15	8.2	40	3/4	152
	80G2UH110CE20 80G2UH110CE20L	110,000	88,000	72,000	59,000	80.0	5	1/2	120-60-1	15	10.0	40	1	156
DOWNFLOW	80G2DF070AE12	66,000	52,000	43,000	35,000	80.0	3	1/2	120-60-1	15	6.1	40	1/2	123
	80G2DF090BE16	88,000	69,000	57,000	46,000	80.0	4	1/2	120-60-1	15	8.2	40	3/4	142

Note: For vent length and clearances to combustibles, please reference installation instructions.  
 Note: Filters and provisions for mounting are not furnished and must be field provided.

**BLOWER PERFORMANCE DATA - UPFLOW / HORIZONTAL****80G2UH045AE12**

External Static Pressure in. w.g.	Air Volume / Watts at Various Blower Speeds									
	High (Black)		Medium-High (Brown)		Medium (Blue)		Medium-Low (Yellow)		Low (Red)	
	cfm	Watts	cfm	Watts	cfm	Watts	cfm	Watts	cfm	Watts
0.00	1500	300	1220	175	1050	114	850	65	800	48
0.10	1485	311	1200	179	1025	118	810	68	790	50
0.20	1460	323	1170	188	980	125	725	73	580	53
0.30	1420	334	1140	195	930	133	670	76	455	54
0.40	1395	343	1095	203	890	138	600	86	375	60
0.50	1355	355	1050	212	840	149	550	93	325	64
0.60	1325	368	1020	222	790	158	495	96	275	67
0.70	1290	369	980	228	745	164	420	103	238	69
0.80	1260	381	945	238	700	172	380	107	---	---

**80G2UH070AE12 / 80G2UH070AE12L**

External Static Pressure in. w.g.	Air Volume / Watts at Various Blower Speeds									
	High (Black)		Medium-High (Brown)		Medium (Blue)		Medium-Low (Yellow)		Low (Red)	
	cfm	Watts	cfm	Watts	cfm	Watts	cfm	Watts	cfm	Watts
0.00	1375	340	1350	240	1110	190	970	93	780	50
0.10	1350	346	1325	254	1100	194	940	104	725	57
0.20	1330	346	1310	264	1080	200	895	113	680	64
0.30	1315	353	1280	272	1060	204	860	118	610	70
0.40	1300	368	1250	283	1040	212	810	125	550	76
0.50	1285	369	1220	293	1010	222	765	132	510	78
0.60	1260	384	1190	301	975	227	725	140	460	83
0.70	1240	391	1150	314	950	236	680	147	400	89
0.80	1210	399	1120	319	915	244	640	152	355	95

**80G2UH090BE12**

External Static Pressure in. w.g.	Air Volume / Watts at Various Blower Speeds									
	High (Black)		Medium-High (Brown)		Medium (Blue)		Medium-Low (Yellow)		Low (Red)	
	cfm	Watts	cfm	Watts	cfm	Watts	cfm	Watts	cfm	Watts
0.00	1605	313	1475	240	1320	173	1050	99	865	60
0.10	1565	323	1430	251	1270	185	995	108	800	68
0.20	1515	334	1380	264	1225	196	935	115	730	76
0.30	1475	347	1340	275	1170	207	870	124	645	83
0.40	1435	360	1300	285	1120	215	805	133	550	91
0.50	1395	369	1250	295	1065	225	715	140	470	98
0.60	1355	378	1205	307	1010	235	655	147	395	101
0.70	1305	391	1160	318	935	246	560	156	345	107
0.80	1265	404	1105	329	875	254	510	162	300	112

**80G2UH090BE16 / 80G2UH090BE16L**

External Static Pressure in. w.g.	Air Volume / Watts at Various Blower Speeds									
	High (Black)		Medium-High (Brown)		Medium (Blue)		Medium-Low (Yellow)		Low (Red)	
	cfm	Watts	cfm	Watts	cfm	Watts	cfm	Watts	cfm	Watts
0.00	1800	370	1555	260	1425	207	1370	172	1240	131
0.10	1765	381	1525	272	1390	218	1320	184	1190	144
0.20	1725	397	1485	283	1350	229	1255	195	1130	157
0.30	1685	416	1450	296	1310	241	1205	206	1075	165
0.40	1635	425	1390	312	1260	250	1165	217	1015	174
0.50	1600	438	1350	322	1205	263	1100	230	955	185
0.60	1560	453	1300	332	1140	270	1050	239	905	193
0.70	1520	467	1255	344	1110	284	1000	249	840	202
0.80	1470	474	1215	352	1050	294	935	258	765	211

**80G2UH110CE16**

External Static Pressure in. w.g.	Air Volume / Watts at Various Blower Speeds									
	High (Black)		Medium-High (Brown)		Medium (Blue)		Medium-Low (Yellow)		Low (Red)	
	cfm	Watts	cfm	Watts	cfm	Watts	cfm	Watts	cfm	Watts
0.00	1780	349	1570	248	1465	190	1370	169	1250	131
0.10	1750	365	1540	260	1420	205	1330	177	1205	140
0.20	1720	382	1500	271	1365	220	1280	187	1155	150
0.30	1675	397	1460	279	1330	228	1250	197	1110	159
0.40	1645	407	1415	291	1290	241	1200	211	1070	166
0.50	1605	424	1395	307	1250	249	1165	219	1015	177
0.60	1580	432	1345	316	1205	258	1105	228	960	186
0.70	1565	448	1300	328	1165	271	1060	237	915	194
0.80	1525	449	1270	339	1125	283	1025	246	865	203

**80G2UH110CE20 / 80G2UH110CE20L**

External Static Pressure in. w.g.		Air Volume / Watts at Different Blower Speeds																												
		Bottom Return Air, Side Return Air from Both Sides or Return Air from Bottom and One Side.									Single Side Return Air - Air volumes in <b>bold</b> (over 1800 cfm) require Optional Return Air Base and field fabricated transition to accommodate 20 x 25 x 1 in. air filter in order to maintain proper air velocity.																			
		High (Black)		Medium-High (Brown)		Medium (Blue)		Medium-Low (Yellow)		Low (Red)		High (Black)		Medium-High (Brown)		Medium (Blue)		Medium-Low (Yellow)		Low (Red)										
cfm	Watts	cfm	Watts	cfm	Watts	cfm	Watts	cfm	Watts	cfm	Watts	cfm	Watts	cfm	Watts	cfm	Watts	cfm	Watts	cfm	Watts									
0.00	2175	590	2050	410	1850	310	1695	275	1510	195	2175	605	1930	420	1785	320	1675	260	1500	195	2175	605	1930	420	1785	320	1675	260	1500	195
0.10	2158	607	1943	421	1778	328	1650	283	1461	205	2129	628	1892	441	1733	345	1627	288	1458	209	2129	628	1892	441	1733	345	1627	288	1458	209
0.20	2131	620	1897	436	1719	345	1591	299	1405	215	2091	649	1838	458	1691	360	1586	297	1407	220	2091	649	1838	458	1691	360	1586	297	1407	220
0.30	2085	639	1847	456	1678	354	1563	308	1351	228	2072	660	1806	471	1631	371	1529	313	1353	232	2072	660	1806	471	1631	371	1529	313	1353	232
0.40	2055	652	1806	466	1641	371	1499	317	1297	238	2014	677	1772	485	1591	385	1485	327	1302	243	2014	677	1772	485	1591	385	1485	327	1302	243
0.50	2030	668	1767	476	1588	387	1462	333	1256	254	1977	690	1742	498	1554	395	1444	337	1252	256	1977	690	1742	498	1554	395	1444	337	1252	256
0.60	1976	686	1724	495	1550	399	1419	348	1215	265	1960	707	1696	511	1511	410	1412	348	1204	265	1960	707	1696	511	1511	410	1412	348	1204	265
0.70	1949	700	1685	510	1512	408	1371	357	1168	271	1913	720	1661	525	1480	424	1351	359	1149	274	1913	720	1661	525	1480	424	1351	359	1149	274
0.80	1896	716	1649	527	1473	419	1332	372	1121	287	1873	738	1617	538	1440	437	1313	371	1117	285	1873	738	1617	538	1440	437	1313	371	1117	285

**BLOWER PERFORMANCE DATA - DOWNFLOW****80G2DF070AE12**

External Static Pressure in. w.g.	Air Volume / Watts at Various Blower Speeds									
	High (Black)		Medium-High (Brown)		Medium (Blue)		Medium-Low (Yellow)		Low (Red)	
	cfm	Watts	cfm	Watts	cfm	Watts	cfm	Watts	cfm	Watts
0.00	1475	346	1345	269	1190	192	970	109	785	71
0.10	1440	355	1325	276	1165	198	935	114	775	74
0.20	1410	365	1280	287	1135	207	905	120	740	79
0.30	1260	401	1250	296	1095	216	855	129	665	86
0.40	1355	380	1225	305	1060	223	815	134	615	92
0.50	1320	394	1200	315	1035	229	770	140	580	97
0.60	1290	401	1160	324	1005	237	745	149	465	105
0.70	1260	410	1130	333	970	245	700	155	445	108
0.80	1215	399	1095	341	935	254	660	158	400	113

**80G2DF090BE16**

External Static Pressure in. w.g.	Air Volume / Watts at Various Blower Speeds									
	High (Black)		Medium-High (Brown)		Medium (Blue)		Medium-Low (Yellow)		Low (Red)	
	cfm	Watts	cfm	Watts	cfm	Watts	cfm	Watts	cfm	Watts
0.10	1700	423	1495	293	1380	233	1295	202	1165	156
0.20	1665	436	1455	307	1330	248	1245	211	1110	166
0.30	1620	452	1415	319	1295	257	1195	221	1055	175
0.40	1585	464	1365	328	1225	269	1140	230	985	185
0.50	1560	471	1325	343	1185	277	1090	240	930	193
0.60	1455	475	1275	355	1120	290	1025	252	875	202
0.70	1405	482	1235	365	1075	295	990	259	840	209
0.80	---	---	1160	369	1025	308	925	268	780	217

**DIMENSIONS (IN.) - UPFLOW POSITION**

Model	A		B		C		D	
	in.	mm	in.	mm	in.	mm	in.	mm
80G2UH045AE12 80G2UH070AE12 80G2UH070AE12L	14-1/2	368	13-3/8	340	13	330	4-3/4	121
80G2UH090BE12 80G2UH090BE16 80G2UH090BE16L	17-1/2	446	16-3/8	416	16	406	6-1/4	159
80G2UH110CE16 80G2UH110CE20 80G2UH110CE20L	21	533	19-7/8	504	19-1/2	495	8	203

**TOP VIEW**

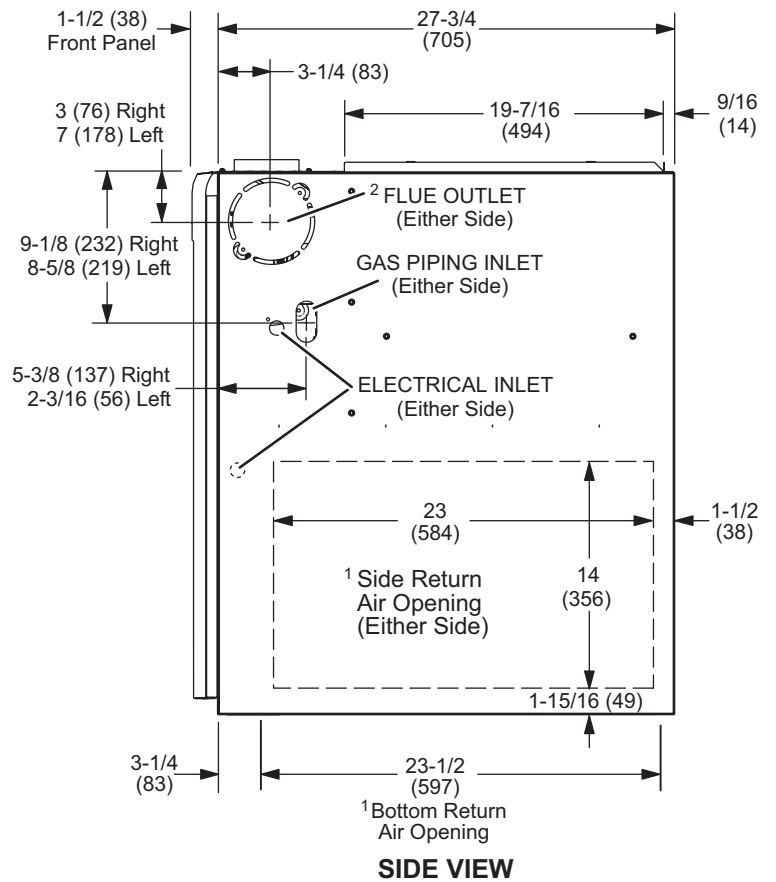
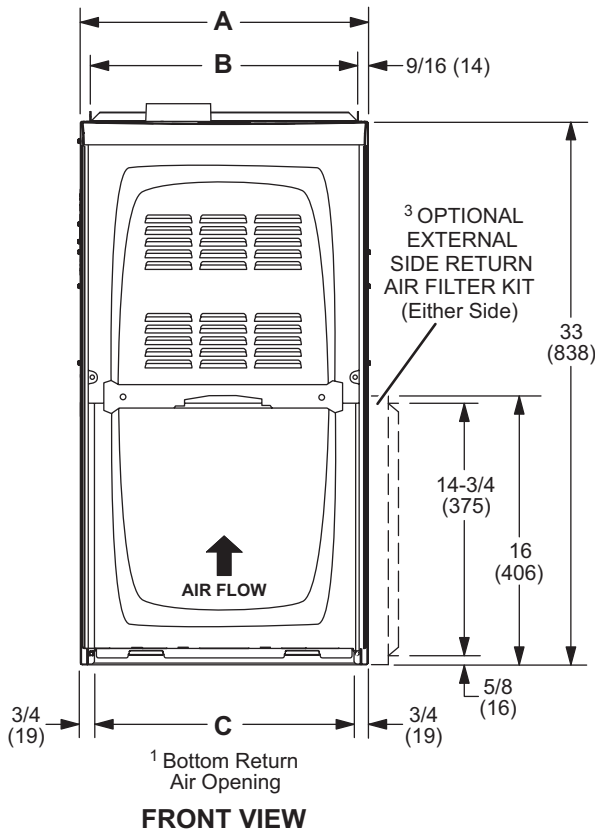
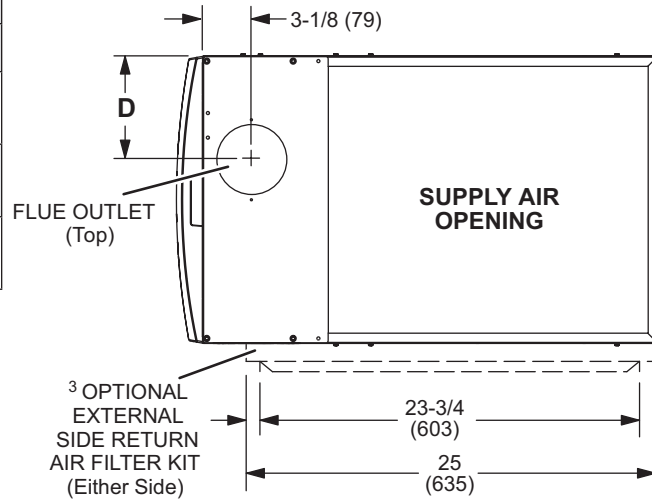

1 NOTE - 60C size units that require air volumes over 1800 cfm must have one of the following:

1. Single side return air and Optional Return Air Base with transition that must accommodate required 20 x 25 x 1 inch (508 x 635 x 25 mm) air filter to maintain proper velocity.
2. Bottom return air.
3. Return air from both sides.
4. Bottom and one side return air. See Blower Performance Tables for additional information.

2 Flue outlet may be horizontal but furnace must be vented vertically

3 Optional External Side Return Air Filter Kit is not for use with the optional Return Air Base.

**DIMENSIONS (IN.) - HORIZONTAL POSITION**

Model	A		B		C		D	
	in.	mm	in.	mm	in.	mm	in.	mm
80G2UH045AE12 80G2UH070AE12 80G2UH070AE12L	14-1/2	368	13-3/8	340	13	330	4-3/4	121
80G2UH090BE12 80G2UH090BE16 80G2UH090BE16L	17-1/2	446	16-3/8	416	16	406	6-1/4	159
80G2UH110CE16 80G2UH110CE20 80G2UH110CE20L	21	533	19-7/8	504	19-1/2	495	8	203

**LEFT-HAND AIR DISCHARGE**

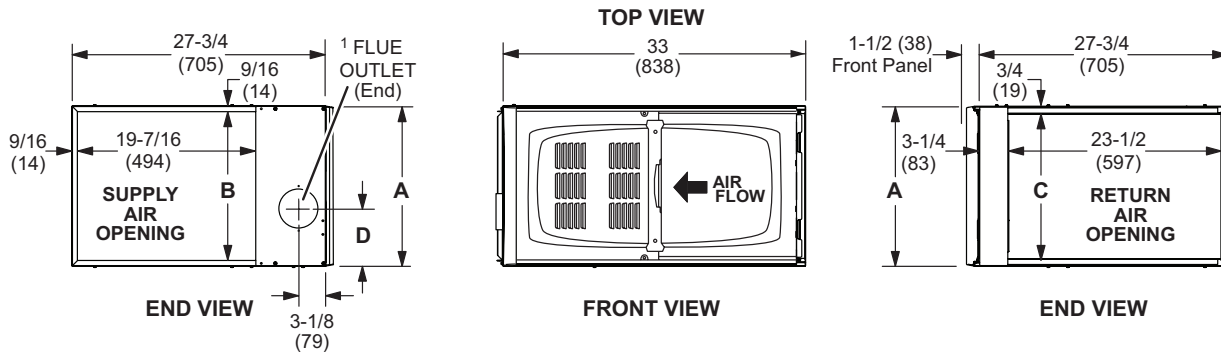
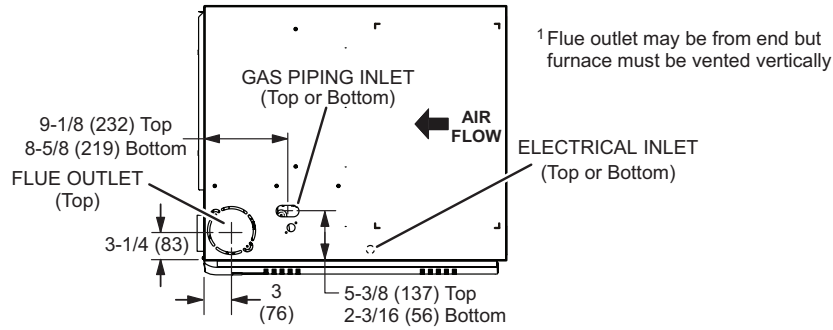

**RIGHT-HAND AIR DISCHARGE**

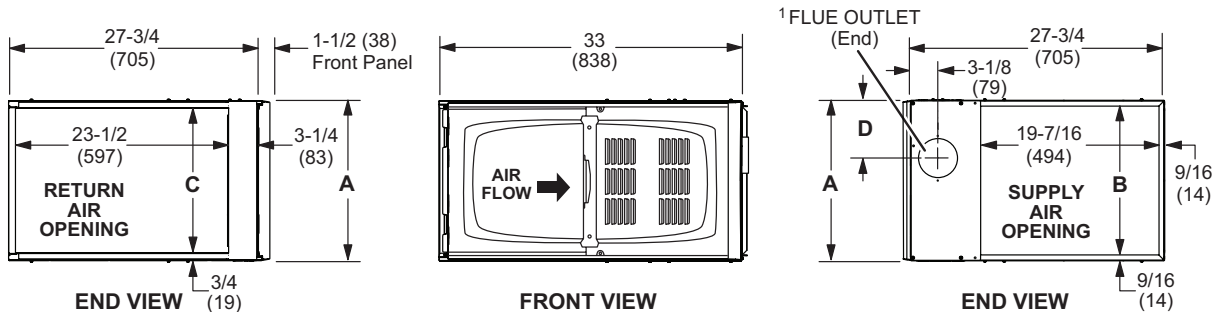
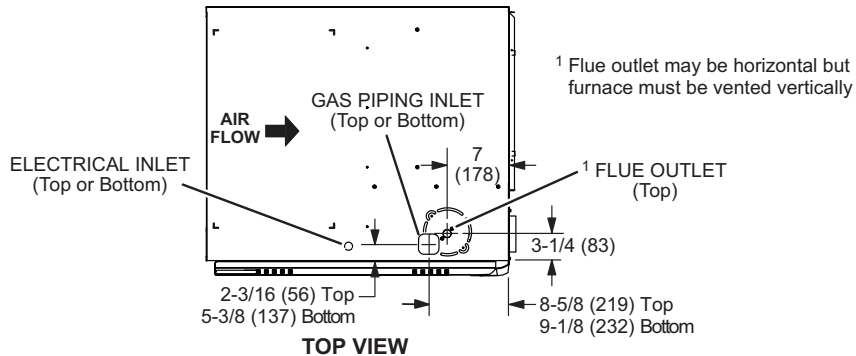



**HORIZONTAL (END) FILTER KIT**

Furnace Cabinet Width	Catalog Number	A		B	
		in.	mm	in.	mm
A	87L95	14	356	12-3/4	324
B	87L96	18	457	16-3/4	425
C	87L97	21	533	18-3/4	476

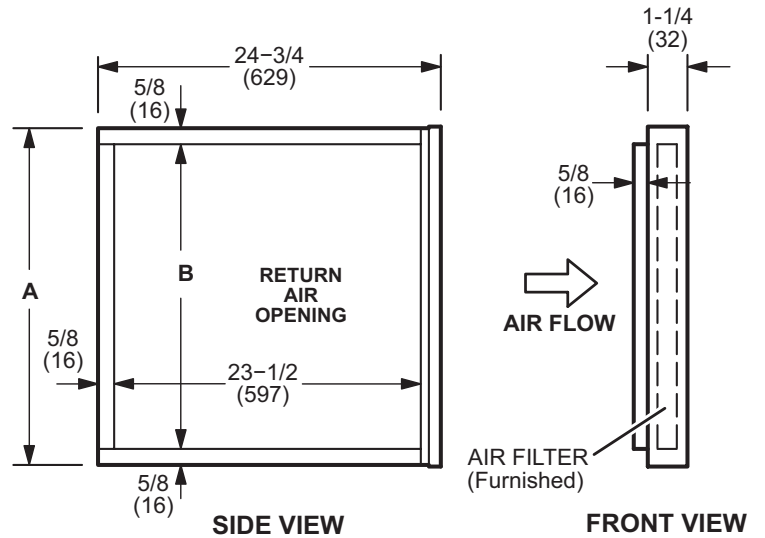

**OPTIONAL RETURN AIR BASE**

(Upflow Applications Only - For use with A, B and C width cabinets)

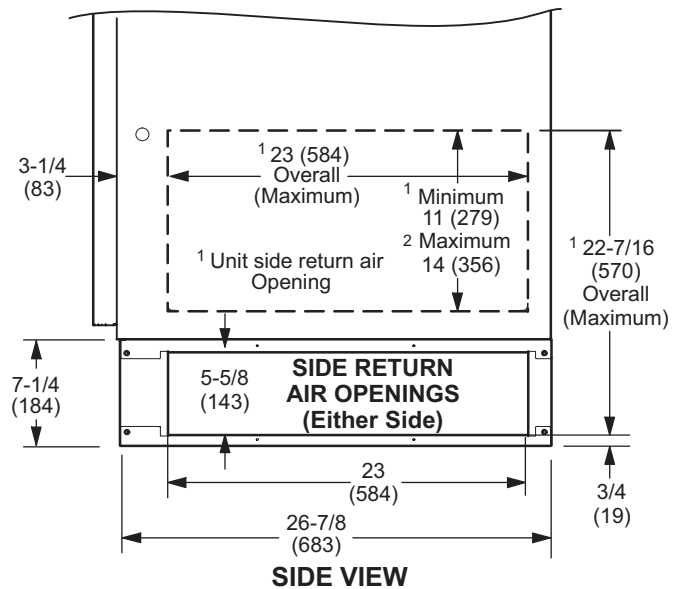
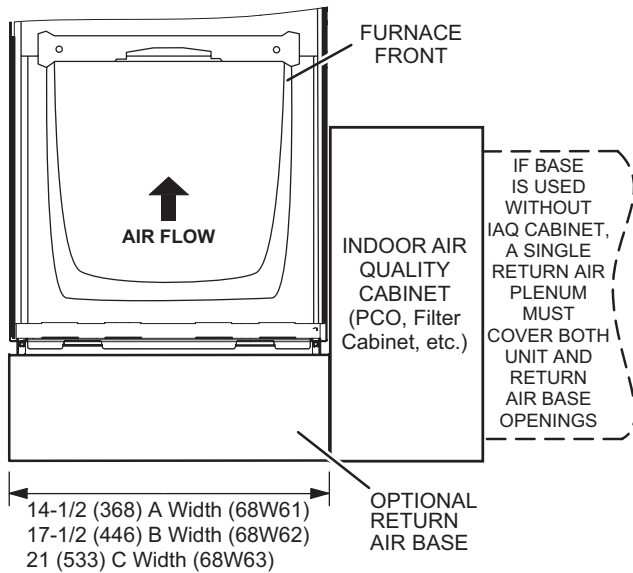

NOTE- Optional Side Return Air Filter Kits are not for use with Optional Return Air Base.

1 Both the unit return air opening and the base return air opening must be covered by a single plenum or IAQ cabinet. Minimum unit side return air opening dimensions for units requiring 1800 cfm or more of air (W x H): 23 x 11 in. (584 x 279 mm). The opening can be cut as needed to accommodate plenum or IAQ cabinet while maintaining dimensions shown. Side return air openings must be cut in the field. There are cutting guides stenciled on the cabinet for the side return air opening. The size of the opening must not extend beyond the markings on the furnace cabinet.

2 To minimize pressure drop, the largest opening height possible, up to 14 in. (356 mm), is preferred.

**FURNACE / COIL COMBINED DIMENSIONS**

**UPFLOW POSITION**

Model	EAC1P/EAC4X Cased				EAU1P Uncased			
	A		B		A		B	
	in.	mm	in.	mm	in.	mm	in.	mm
EA*1P/EAC4X18/24A EA*1P/EAC4X18/24B	16-1/2	419	49-1/2	1257	14-1/8	359	47-1/8	1197
EA*1P/EAC4X24A EA*1P/EAC4X24B	18-1/2	470	51-1/2	1308	16-3/8	416	49-3/8	1254
EA*1P/EAC4X30A EA*1P/EAC4X30B	22-1/2	572	55-1/2	1410	20-3/4	527	53-3/4	1365
EA*1P/EAC4X30A/36A EA*1P/EAC4X30B/36B EA*1P/EAC4X30A/36C	24-1/2	622	57-1/2	1461	22-1/4	565	55-1/4	1403
EA*1P/EAC4X36A EA*1P/EAC4X36B	24-1/2	622	57-1/2	1461	22-3/8	568	55-3/8	1407
EA*1P/EAC4X48B EA*1P/EAC4X48C	27-1/2	699	60-1/2	1537	26-1/4	667	59-1/4	1505
EA*1P/EAC4X49C	29-1/2	749	62-1/2	1588	28-1/2	724	61-1/2	1562
EA*1P/EAC4X50/60C	27-1/2	699	60-1/2	1537	25-7/8	657	58-7/8	1495
EAC4X60C	31-1/2	800	64-1/2	1638	30-5/8	778	63-5/8	1616

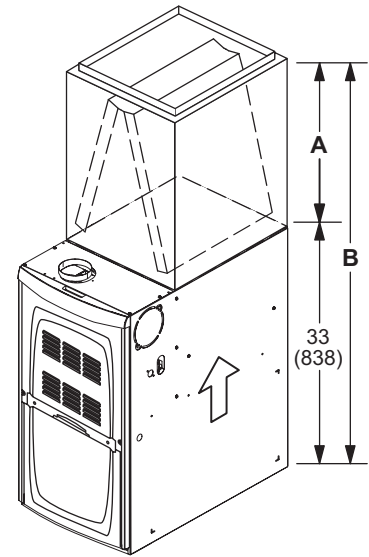

**HORIZONTAL POSITION**

Model		A		B	
		in.	mm	in.	mm
EAHIP18A EAHIP24A EAHIP24B EAHIP30B	EAHIP36A EAHIP36B EAHIP36C EAHIP42C EAHIP48C	26-1/2	673	59-1/2	1511
EAHIP30A EAHIP42B EAHIP48B	EAHIP51C EAHIP60D	31-1/2	880	64-1/2	1638

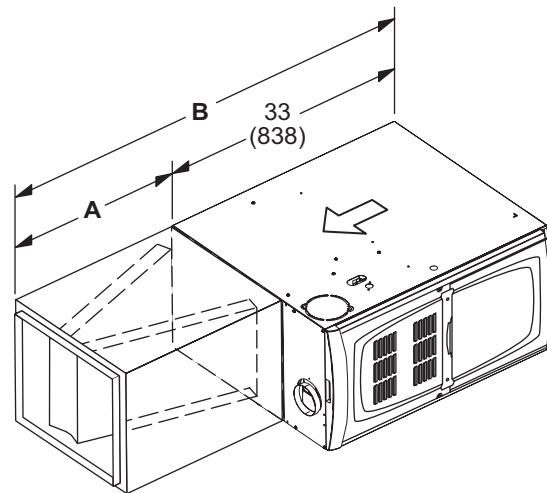

**DIMENSIONS (IN.) - DOWNFLOW POSITION**

Model	A		B		C		D	
	in.	mm	in.	mm	in.	mm	in.	mm
80G2DF070AE12	14-1/2	368	13-3/8	340	13	330	4-3/4	121
80G2DF090BE16	17-1/2	446	16-3/8	416	16	406	6-1/4	159

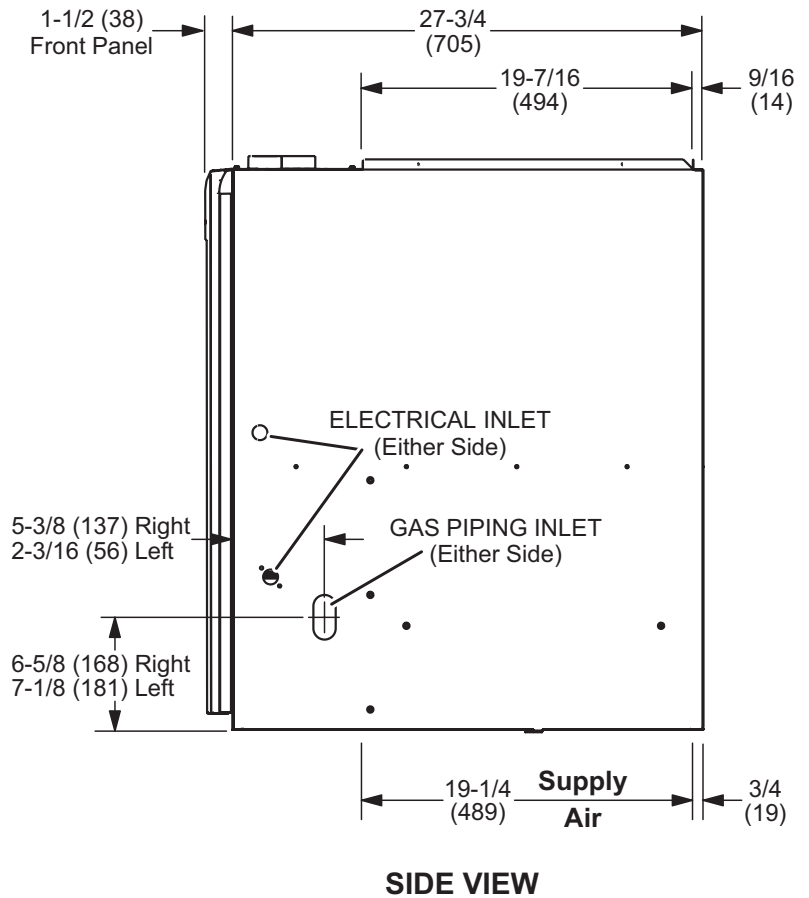
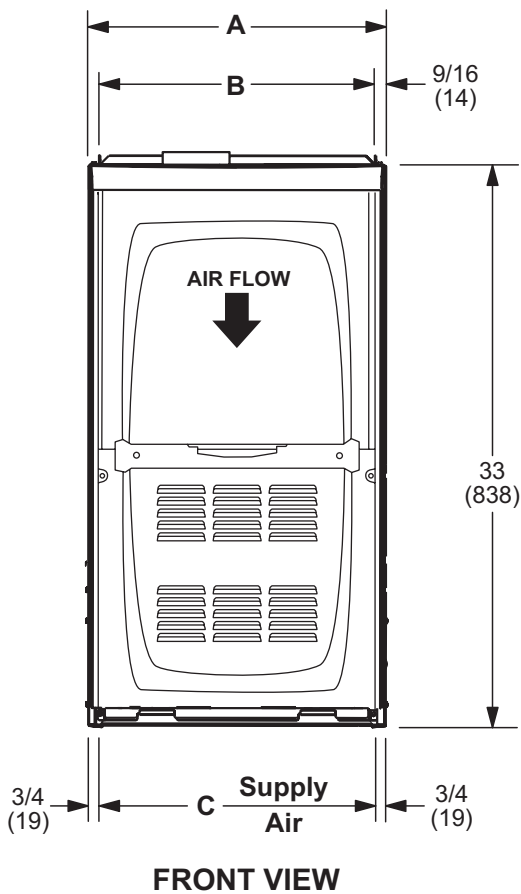
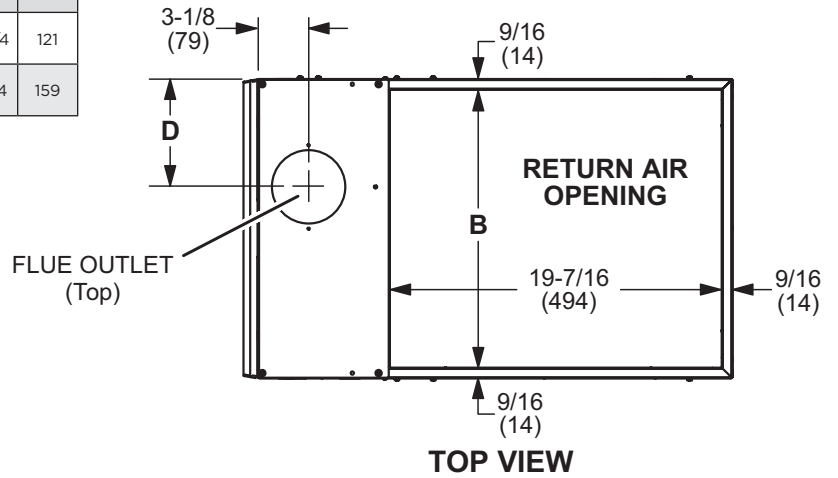

**DOWNFLOW COMBUSTIBLE FLOORING BASE**

Furnace Cabinet Width	Catalog Number	A		B		C	
		in.	mm	in.	mm	in.	mm
A	11M59	16-9/16	421	13-9/16	344	15-3/4	400
B	11M60	19-9/16	497	16-9/16	421	18-3/4	476

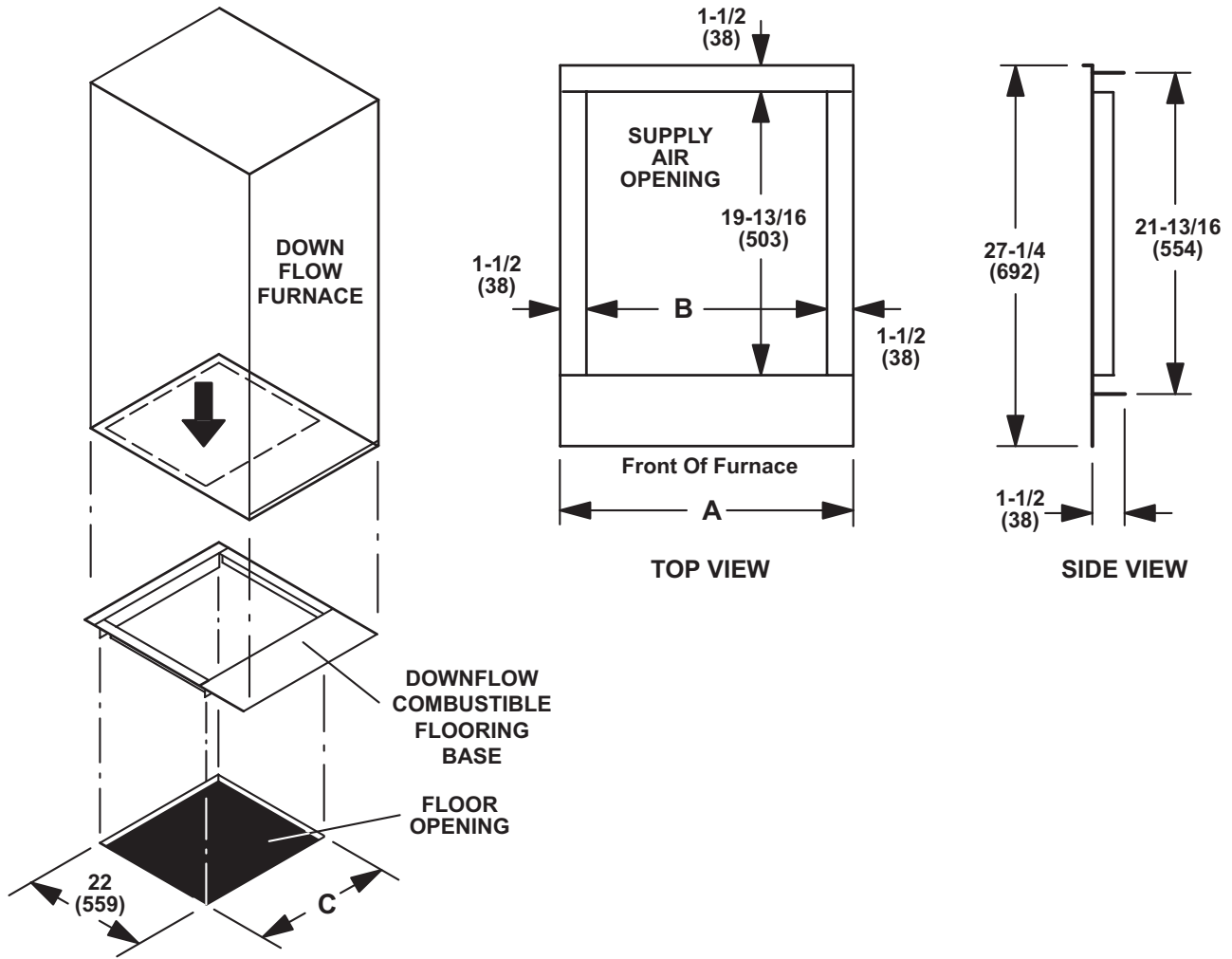

**DIMENSIONS - DOWNFLOW FILTER CABINET**

**DOWNFLOW FILTER CABINET**

**“A” WIDTH FURNACES  
(Single Filter)**

**“B” WIDTH FURNACES  
(Two Filters)**

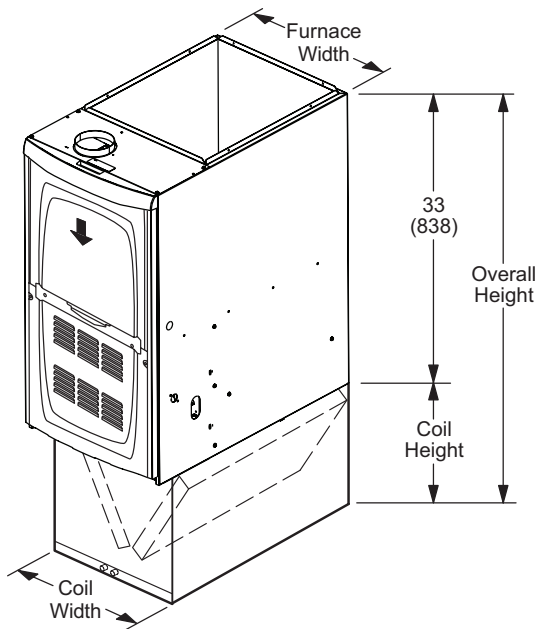
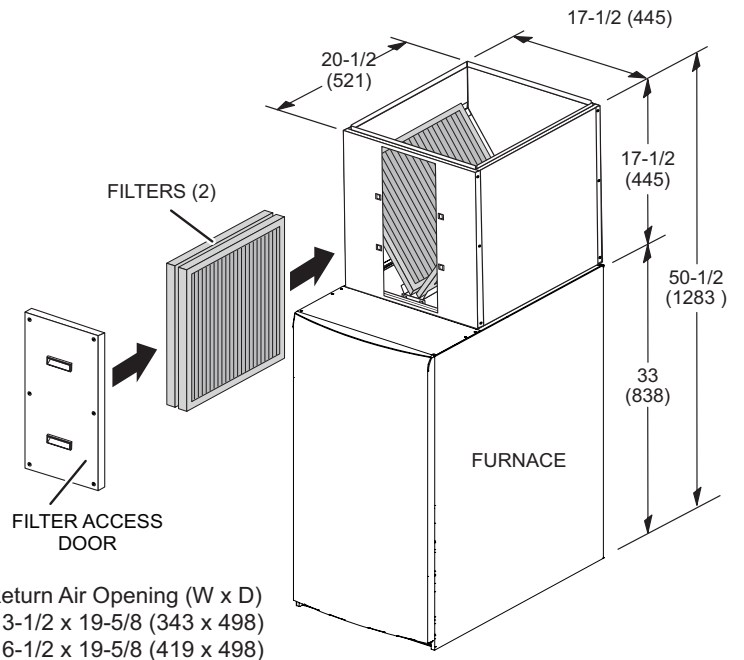
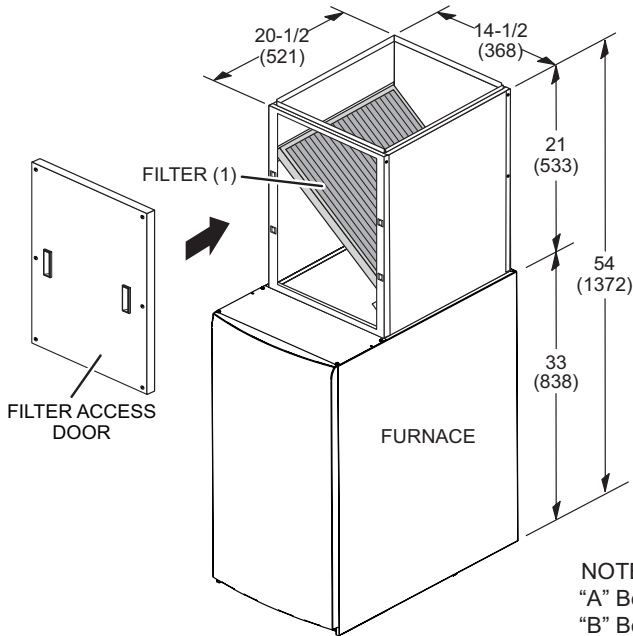

**FURNACE / COIL COMBINED DIMENSIONS**

**DOWNFLOW POSITION**

Model	Coil Width		Furnace Width		Coil Height		Overall Height	
	in.	mm	in.	mm	in.	mm	in.	mm
EDIP-18A	17-1/2	446	14-1/2	368	14-1/8	359	47-1/8	1197
EDIP-24A	17-1/2	446	14-1/2	368	14-1/8	359	47-1/8	1197
EDIP-24B	17-1/2	446	17-1/2	446	14-1/8	359	47-1/8	1197
EDIP-30/36A	17-1/2	446	14-1/2	368	16-1/8	410	49-1/8	1248
EDIP-30/36B	17-1/2	446	17-1/2	446	16-1/8	410	49-1/8	1248
EDIP-48B	21	533	17-1/2	446	20	508	53	1346

**ACCESSORIES**

ACCESSORY	CATALOG NUMBER
<b>RETURN AIR BASE</b>	
Return Air Base 14.5"	68W61
Return Air Base 17.5"	68W62
Return Air Base 21.0"	68W62
<b>HIGH ALTITUDE PRESSURE SWITCHES</b>	
2-Stage 80% UH/DF (4,501 - 7,500 ft) [045, 070, 090, 110]	91W53
2-Stage 80% UH/DF (7,501 - 10,000 ft) [045, 070, 090, 110]	73W35
<b>HIGH ALTITUDE ORIFICE KITS (7,500 ft+)</b>	
2-Stage 80% UH/DF - Natural Gas	51W01
2-Stage 80% UH/DF - Propane Gas	11K47
<b>NATURAL TO LP KITS</b>	
2-Stage 80% UH/DF (0 - 7,500 ft)	11K48
2-Stage 80% UH/DF (7,501 - 10,000 ft)	11K47
<b>LP TO NATURAL KITS</b>	
2-Stage 80% UH/DF	77W10
<b>DOWNFLOW SPECIFIC AIR FILTERS</b>	
14.5"	51W06
17.5"	51W07
<b>DOWNFLOW COMBUSTIBLE FLOORING BASE</b>	
14.5"	11M59
17.5"	11M60
<b>NIGHT SERVICE KITS</b>	
2-Stage	22J94
<b>HORIZONTAL SUSPENSION KIT</b>	
80% & 90%	51W10
<b>EXTERNAL FILTER RACK KITS</b>	
1 pack (16 x 25)	1.841018
10 pack (16 x 25)	1.841039
<b>TWINNING KIT</b>	
Constant Torque Gas Furnace Twinning Kit	16W72

*For vent length and clearances to combustibles, please reference installation instructions.*



1-800-448-5872

All specifications and illustrations  
subject to change without notice and  
without incurring obligations.