

In-line Expansion Joint Installation

Key:

□ = Style 150/155/155P/E155/
W155/355/355P

X = Anchor

— = Guide

All illustrations in this publication have been exaggerated for clarity.

Victaulic® Style 150 Mover® and Style 155/155P/E155/W155/355/355P Expansion Joints are designed to accommodate “in-line” pipe expansion and contraction generated by thermal changes in a limited amount of space. When installed in accordance with the guidelines of this sheet, they will provide for an excellent means of accommodating pipeline expansion or contraction.

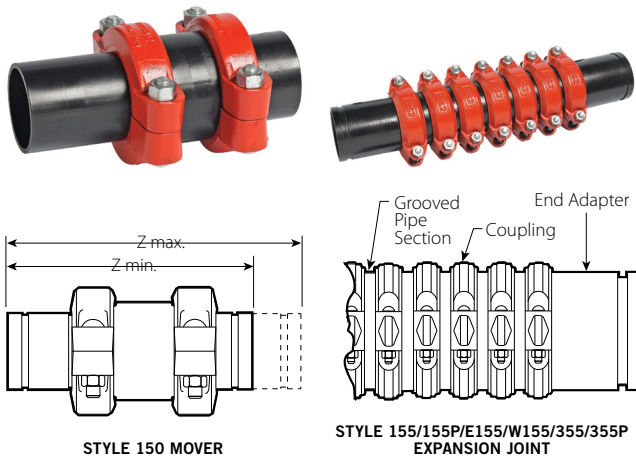

Victaulic offers two distinct types of products for in-line compensation of thermal movement. Our Style 150 Mover, offered in sizes 2"/DN50, 3"/DN80, 4"/DN100 and 6"/DN150, is a slip-type expansion compensation device where a slide telescopes within a sleeve and compensates up to 3"/76 mm of linear movement (see [publication 09.04](#) for additional information). Our Style 155 Expansion Joint, offered in sizes ¾ – 12"/DN20 – DN300, our Style 155P Expansion Joint, offered in sizes 2 – 12"/DN50 – DN300, our Style E155 Expansion Joint, offered in sizes 2 – 12"/DN50 – DN300, our Style W155 Expansion Joint, offered in sizes 14 – 24"/DN350 – DN600, and our Style 355 Expansion Joint, offered in sizes 2 – 12"/DN50 – DN300, consist of a series of Victaulic grooved flexible couplings and specially grooved pipe nipples (see publications [09.05](#), [09.25](#), [31.07](#), [20.12](#) and [33.05](#), respectively, for additional information). When the required movement compensation is more than 50% above the amount provided by a standard Style 155/155P/E155/W155/355/355P, then multiple, smaller units are recommended over one customized larger unit.

The smaller units will ease handling and installation/supporting requirements.

As with all in-line type expansion compensation devices, our Style 150 Movers and Style 155/155P/E155/W155/355/355P Expansion Joints shall be installed on straight pipe runs between opposing anchors. The anchors serve to direct the thermal movement towards the expansion joint. The anchors also prevent the expansion joints from opening up to their maximum expanded length due to system pressurization.

Anchored – Controlled Movement

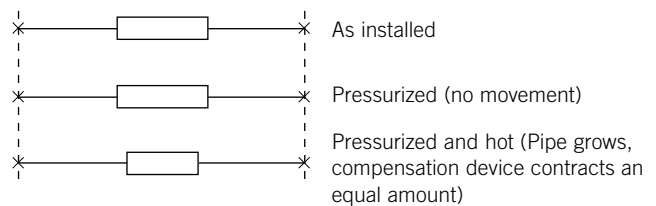

In an uncontrolled (no anchors) installation, thermal movement will occur in the path of least resistance, which is unpredictable and may occur at the expansion joint or at the ends of the pipe runs. Both our Style 150 Movers and Style 155/155P/E155/W155/355/355P Expansion Joints require an activation force roughly equivalent to the end load generated by 15 psi/1 bar of internal pressure. Without anchors, pressure generated movement will expand the compensation device to its maximum length and any thermal changes will be directed in the path of least resistance.

Anchored – Uncontrolled Movement

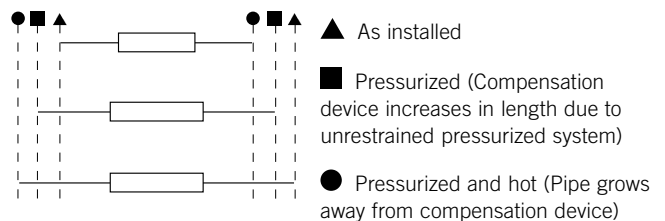

Some systems may require the installation of intermediate anchors. An intermediate anchor is an anchor that is installed between two anchors on a straight run of pipe. Intermediate anchors prevent thermal movement at its location but are not subject to the pressure thrust loads imparted on main anchors (see [publication 26.01](#) for additional information). The purpose for intermediate anchors is to reduce (or eliminate) thermal movement at branch connections or to “break-up” long straight pipe runs into smaller sections, thereby reducing the thermal movement compensation required at each expansion joint.

ALWAYS REFER TO ANY NOTIFICATIONS AT THE END OF THIS DOCUMENT REGARDING PRODUCT INSTALLATION, MAINTENANCE OR SUPPORT.



Style 150 Movers or Style 155/155P/E155/W155/355/355P Expansion Joints shall be installed between any anchors (main or intermediate) on straight pipe runs. **Good piping practice dictates that straight pipe between anchors must have sufficient in-line expansion capability to accommodate for thermal expansion or contraction.**

In addition to anchors, the pipe must be guided on both sides of Style 150 Movers and Style 155/155P/E155/W155/355/355P Expansion Joints to ensure their satisfactory performance. Angular deflection at a Style 150 Mover will cause damage to the unit as the slide travels within the sleeve. Two guides shall be installed on a single piece of pipe joined directly to either side of the unit. Guides shall be spaced to prevent any deflection of the pipe from the centerline. When system conditions permit, the guides on one side of the expansion compensation device can be eliminated by locating the unit adjacent (within 4 pipe diameters) to an anchor.

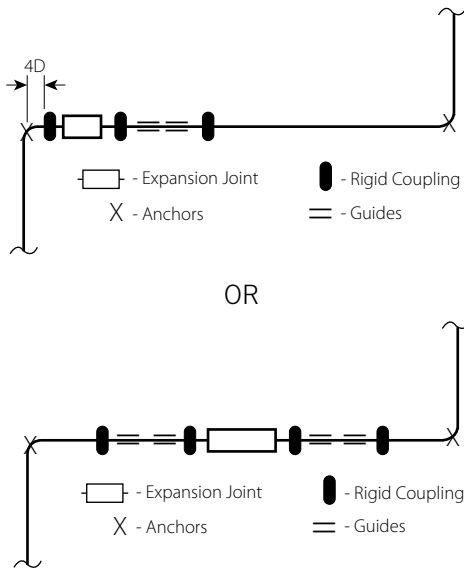

At the system designers option, some long straight pipe runs may require additional guides to maintain pipe alignment and prevent “bowing” and pipe joint deflection on areas remote from the expansion compensation device. The use of Victaulic rigid couplings with proper pipe support spacing (see [publication 26.01](#) for additional information) may eliminate the need for the additional guides.

In the installed system, the distance between the

anchors remains constant over the full temperature gradient. Style 150 Movers and Style 155/155P/E155/W155/355/355P Expansion Joints accommodate pipeline thermal movement by increasing or decreasing their length an amount equal and opposite to the pipeline expansion or contraction.

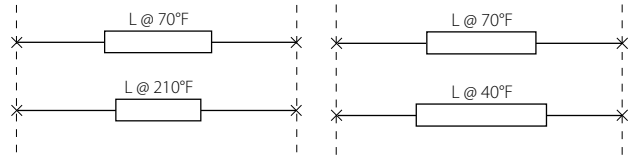

The installed length of the units is critical to proper operation. Several factors shall be considered. To determine the appropriate installation length, the temperature extremes and the installation temperature (at the time the pipe is anchored) shall be known. In systems where the installation temperature is also one of the temperature extremes, the following is true. Full extension of the units will allow them to reduce in length as temperature increases and the pipes grow. Similarly, full compression of the units will allow them to increase in length as the temperature decreases and the pipes shrink. For systems where the installation temperature is within the range of extremes, the units’ installed length must fall within the maximum and minimum unit length, inversely proportional to where the installation temperature falls within the maximum and minimum system temperatures (see the installation example below.)

Style 150 Movers are field adjustable to obtain the correct installation length. The installation length of Style 155/155P/E155/W155/355/355P Expansion Joints are factory set based upon customer supplied installation and extreme temperatures. Style 155/155P/E155/W155/355/355P Expansion Joints are secured with tie rods which must be removed after the units and anchors have been installed in the system. Both style expansion compensation devices shall be assembled in to the piping system using Victaulic grooved rigid couplings.

It is recommended in both horizontal and vertical applications that Style 155/155P/E155/W155/355/355P units be supported so that the in-line movement capability of the units is not compromised by sag or deflection after installation. Suggested support types are illustrated on pages 4 and 5 below for consideration.

Installation Example

A system is designed to operate within the temperature range of 0°F to 100°F/-18°C to -38°C. The thermal movement is calculated based on the temperature range and the piping material. An expansion compensation device is selected that will accommodate the calculated movement. If the following installation temperatures are present, then the settings of the expansion compensation device within the range of its minimum and maximum lengths are as follows:

Installation Temperature	Installation Length
0°F/-18°C	Maximum (Fully expanded)
+25°F/-4°C	75% Extended
+50°F/+10°C	50% (Half-way between fully expanded and fully compressed)
+75°F/+24°C	25% Extended
+100°F/+38°C	Minimum (Fully compressed)

Putting numbers to this example, let's assume that a 4"/DN100 carbon steel pipeline travels in a straight line with a distance of 400 ft/122 m between the anchors. This distance will remain constant as it is not affected by the pipeline temperature. Using the methodology discussed in section 1 of [publication 26.02](#), the calculated thermal movement in the 400 ft/122 m length will be 3"/76 mm (over a +100°F/+38°C temperature change). The 4"/DN100 Victaulic Style 150 Mover will accommodate up to 3"/76 mm of pipeline growth. A compressed unit has an end to end length of 14.13"/359 mm and an extended length of 17.13"/435 mm. See [publication 09.04](#) for additional information on the Style 150 Mover.

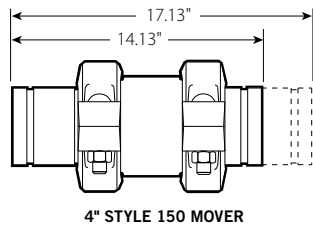

Following the above methodology, if the temperature of the pipeline at the time of installation or anchoring is 0°F/-18°C, then the Mover should be at its fully extended length of 17.13"/435 mm.

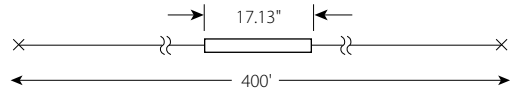

If the temperature of the pipeline at the time of installation or anchoring is +25°F/-4°C, then the length of the Mover should be 16.38"/416 mm, $\{[(17.13" - 14.13") \times 0.75] + 14.13"\}$.

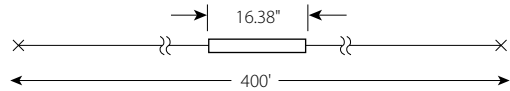

If the temperature of the pipeline at the time of installation or anchoring is +50°F/+10°C, then the length of the Mover should be 15.63"/397 mm, $\{[(17.13" - 14.13") \times 0.5] + 14.13"\}$.

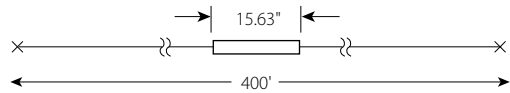

If the temperature of the pipeline at the time of installation or anchoring is +75°F/+24°C, then the length of the Mover should be 14.88"/378 mm, $\{[(17.13" - 14.13") \times 0.25] + 14.13"\}$.

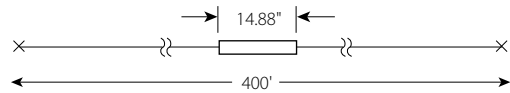

If the temperature of the pipeline at the time of installation or anchoring is +100°F/+38°C, then the Mover should be at its fully compressed length of 14.13"/359 mm.

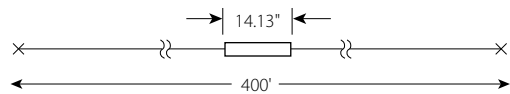

Suggested Supports for Victaulic Expansion Joints

Horizontal

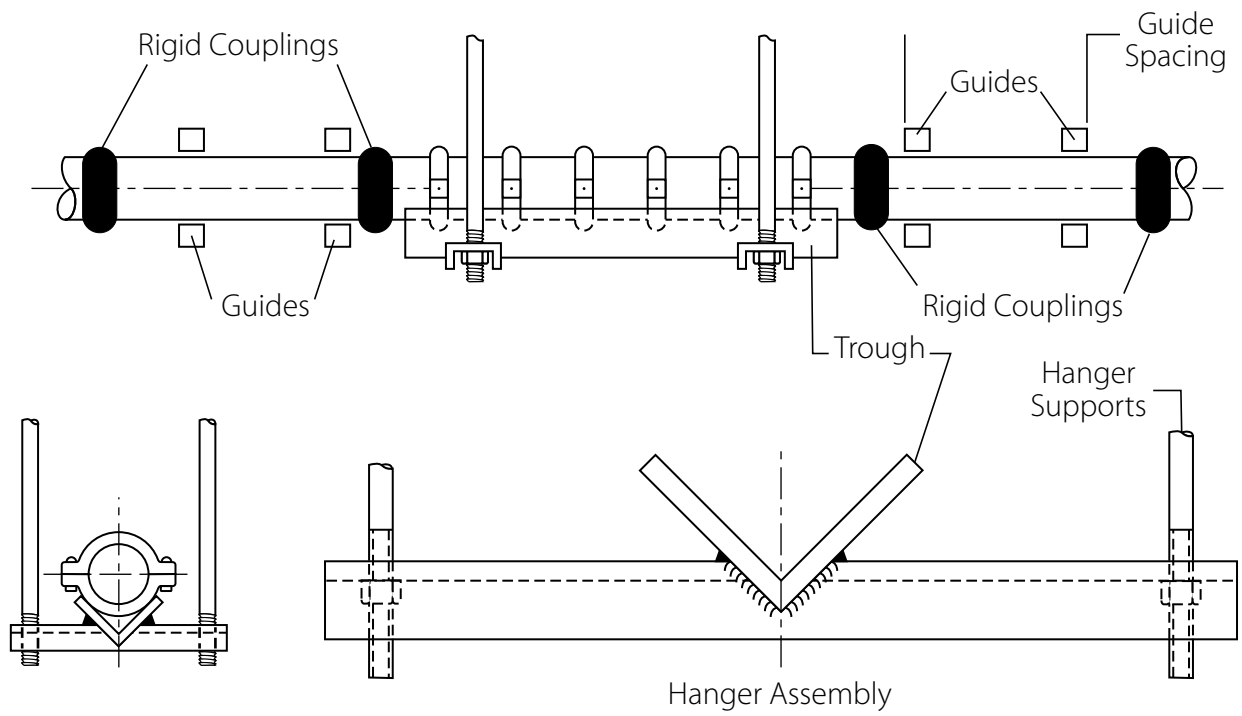

Suggested Supports for Victaulic Expansion Joints

Vertical

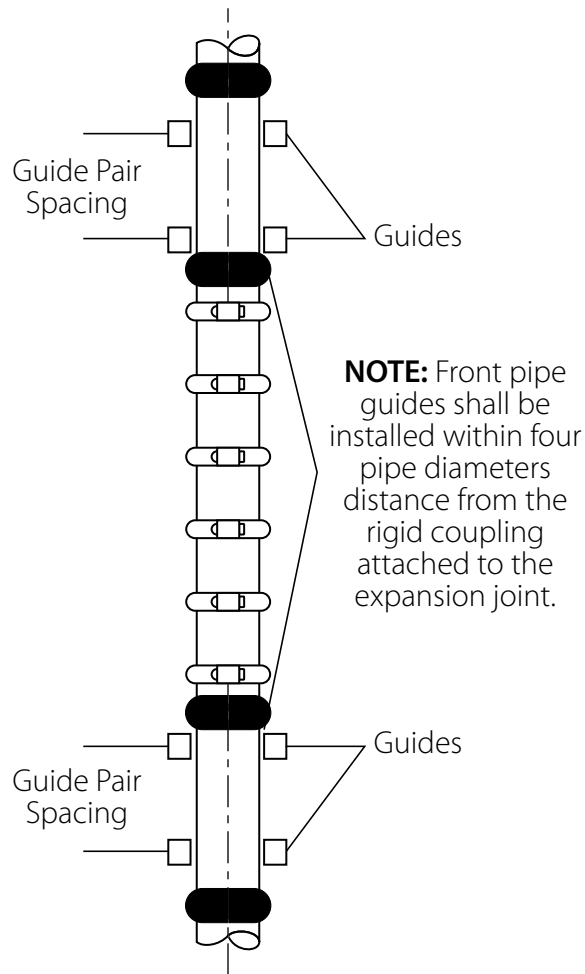

Guide pair space requirements:
Minimum = 12 pipe diameters
Maximum = 14 pipe diameters

Cradle Vertical Support

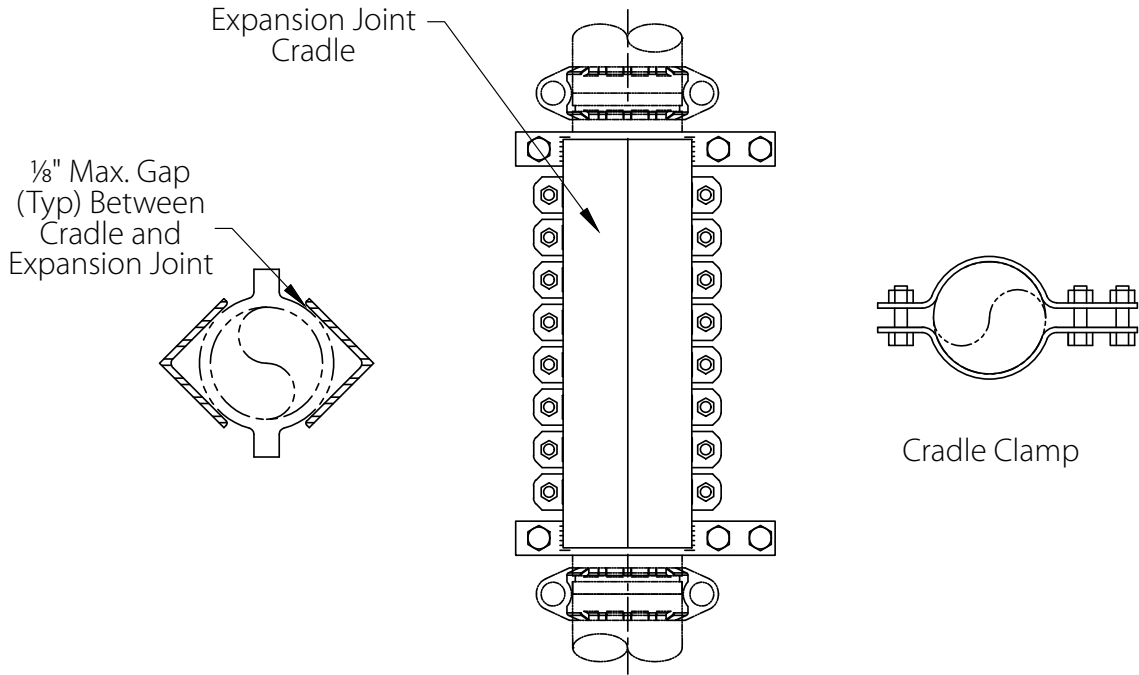

User Responsibility for Product Selection and Suitability

Each user bears final responsibility for making a determination as to the suitability of Victaulic products for a particular end-use application, in accordance with industry standards and project specifications, as well as Victaulic performance, maintenance, safety, and warning instructions. Nothing in this or any other document, nor any verbal recommendation, advice, or opinion from any Victaulic employee, shall be deemed to alter, vary, supersede, or waive any provision of Victaulic Company's standard conditions of sale, installation guide, or this disclaimer.

Intellectual Property Rights

No statement contained herein concerning a possible or suggested use of any material, product, service, or design is intended, or should be construed, to grant any license under any patent or other intellectual property right of Victaulic or any of its subsidiaries or affiliates covering such use or design, or as a recommendation for the use of such material, product, service, or design in the infringement of any patent or other intellectual property right. The terms "Patented" or "Patent Pending" refer to design or utility patents or patent applications for articles and/or methods of use in the United States and/or other countries.

Note

This product shall be manufactured by Victaulic or to Victaulic specifications. All products to be installed in accordance with current Victaulic installation/assembly instructions. Victaulic reserves the right to change product specifications, designs and standard equipment without notice and without incurring obligations.

Installation

Reference should always be made to the Victaulic installation handbook or installation instructions of the product you are installing. Handbooks are included with each shipment of Victaulic products, providing complete installation and assembly data, and are available in PDF format on our website at www.victaulic.com.

Warranty

Refer to the Warranty section of the current Price List or contact Victaulic for details.

Trademarks

Victaulic and all other Victaulic marks are the trademarks or registered trademarks of Victaulic Company, and/or its affiliated entities, in the U.S. and/or other countries.