

### Installation Support • Soporte de Instalación • Support d'Installation

#### Personal Assistance, Product Specs, & "How-to" Questions:

Asistencia personal, especificaciones del producto y preguntas sobre "cómo hacerlo":  
Aide personnelle, spécifications du produit et questions « pratico-pratiques » :

**1-800-PFAUCET (732-8238)**  
**pfisterfaucets.com/support**

Installation Videos Available  
Videos de instalación a disposición  
Vidéos d'installation disponibles



pfisterfaucets.com/videos

#### ▲ WARNING / AVERTENCIA / AVERTISSEMENT

To reduce the risk of injury or property damage, read all instructions before installing product. Wear safety goggles. Product must be installed in accordance with all state & local plumbing & building codes. Call a professional if you are uncertain about installing this product.

Para disminuir el riesgo de lesiones o daños a la propiedad, lea todas las instrucciones antes de instalar el producto. Utilice gafas de seguridad. El producto deberá instalarse de acuerdo con la normativa de plomería y construcción estatal y local. Llame a un profesional si no está seguro sobre cómo instalar este producto.

Pour réduire le risque de blessures ou de dommages, lire toutes les instructions avant d'installer l'appareil. Porter des lunettes de sécurité. Il faut installer l'appareil en respectant tous les codes de construction et de plomberie locaux et d'État. Appelez un professionnel si vous n'êtes pas certain de la façon d'installer cet appareil.

#### Required Tools Herramientas necesarias Outils nécessaires



Adjustable Wrench  
Llave ajustable  
Clé réglable



6mm Hex Wrench  
6mm Llave hexagonal  
6mm Clé hexagonale



Safety Goggles  
Gafas de seguridad  
Lunettes de sûreté



PTFE plumber's tape  
Cinta para plomería PTFE  
Ruban PTFE de plombier

#### Additional Helpful Tools Otras herramientas útiles Outils supplémentaires utiles

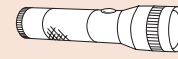

Flashlight  
Linterna  
Lampe-torche



Cloth  
Paño  
Chiffon

#### Parts in the Box Piezas en la caja Pièces dans la boîte

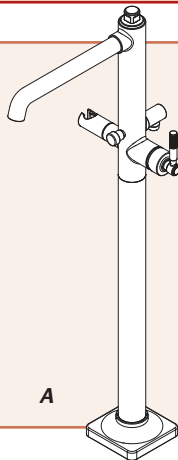

Aerator Tool  
Herramienta para el aireador  
Outil d'aérateur

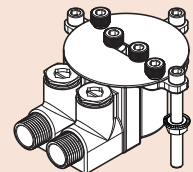

OX6-270R Valve sold separately  
OX6-270R Válvula se vende por separado  
OX6-270R Valve vendu séparément

## 1 Turn Off Water Supply • Cierre el suministro de agua • Couper l'alimentation en eau

Locate the water supply inlets & shut off the water supply valves. These are usually found near the water meter.

If you are replacing an existing unit, remove the old unit & clean mounting surface thoroughly.

Ubique las entradas del suministro de agua y cierre las válvulas de suministro. Estas se encuentran generalmente cerca del medidor de agua. Si reemplaza una unidad existente, retírela y limpie completamente la superficie de montaje.

Repérez les entrées d'alimentation d'eau et fermez les robinets d'arrêt. Ils sont normalement trouvés près du compteur d'eau. Si vous remplacez un appareil existant, enlevez le vieil appareil et nettoyez soigneusement la surface de montage.

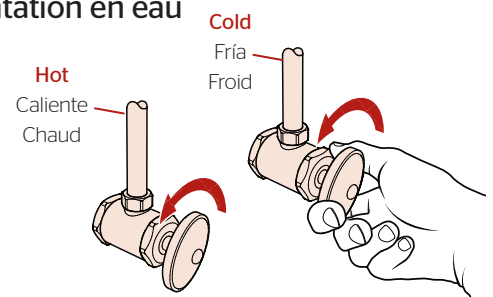

## 2 Spout Orientation

Prepare la tubería empotrada y configure la rotación del vástago

Préparez la plomberie brute et réglez la rotation

### Pick where Faucet will be installed

Recogida en donde se instalará el grifo

Choisissez où le robinet sera installé

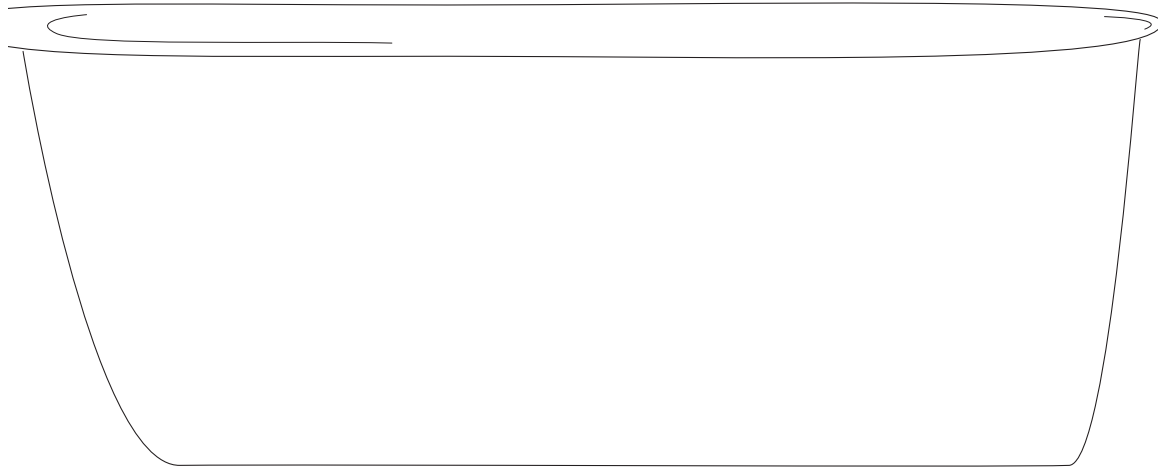

## 3 Prepare the Valve

Instale la Válvula

Installez la Soupape

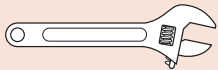

Adjustable Wrench  
Llave ajustable  
Clé réglable



PTFE plumber's tape  
Cinta para plomería PTFE  
Ruban PTFE de plombier



6mm Hex Wrench  
6mm Llave hexagonal  
6mm Clé hexagonale

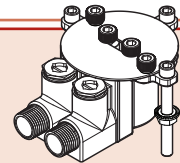

OX6-27OR Valve sold separately  
OX6-27OR Válvula se vende por separado  
OX6-27OR Valve vendu séparément

3A



trash basura poubelle

6mm

Wrap plumber's tape on male threads **BEFORE** installing.

Envuelva la cinta de plomero en en las roscas macho **ANTES** de instalar.  
Enveloppez le ruban de plombier sur les filets mâles **AVANT** d'installer.

1/2-14 NPT

3B

# 4

## Install Body

Instale el Cuerpo

Installez le corps

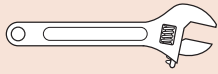

Adjustable Wrench  
Llave ajustable  
Clé réglable



6mm Hex Wrench  
6mm Llave hexagonal  
6mm Clé hexagonale

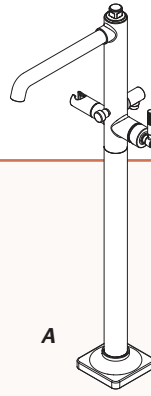

A

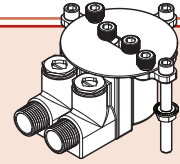

OX6-270R Valve sold separately  
OX6-270R Válvula se vende por separado  
OX6-270R Valve vendu séparément

4A

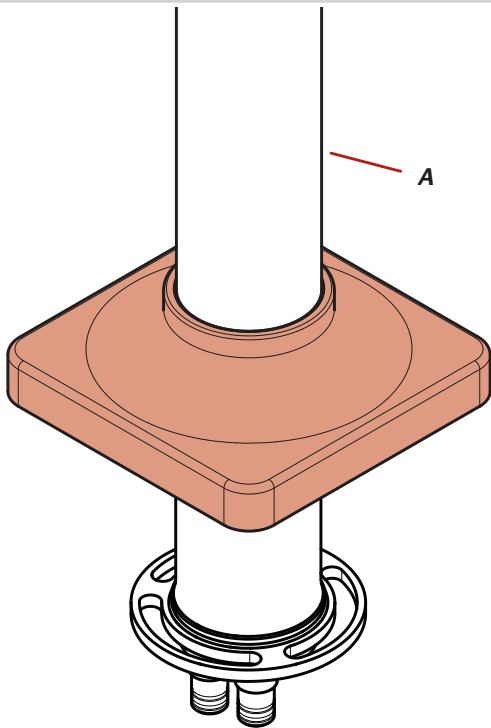

4C

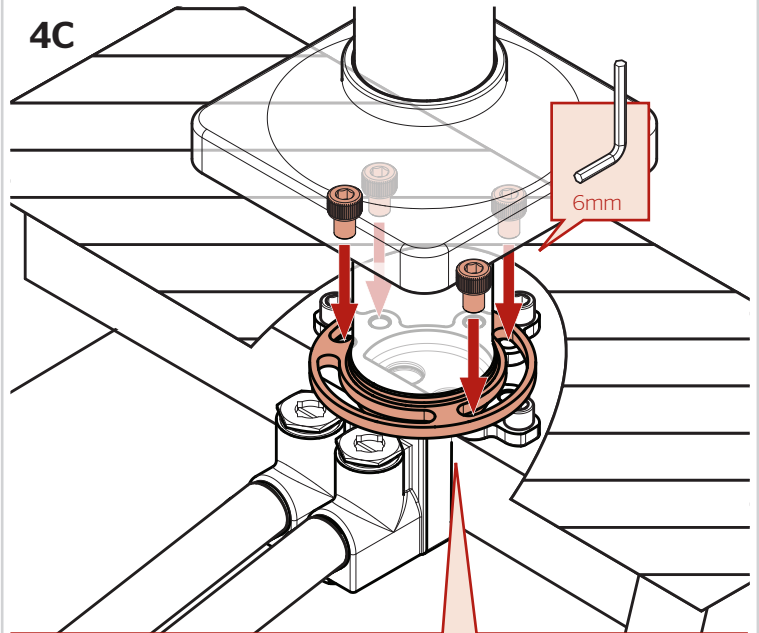

Insert Screws to 1 of 2 spots on the 3 prongs depending how flange (A) aligned.  
Inserte los tornillos a 1 de 2 puntos en las 3 puntas dependiendo de cómo brida (A) alineo.  
Insérer les vis 1 février points 3 points en fonction de la brida (A) alignés.

4B

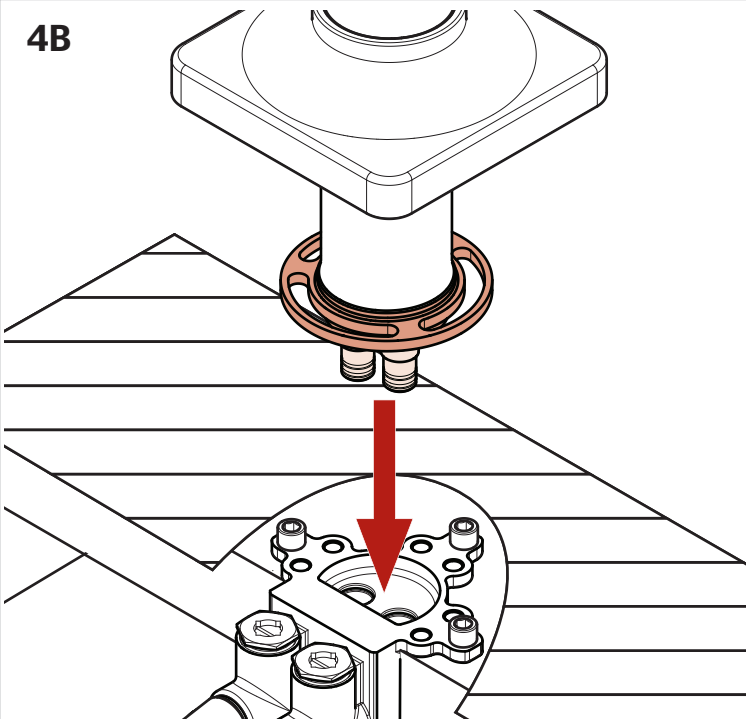

4D

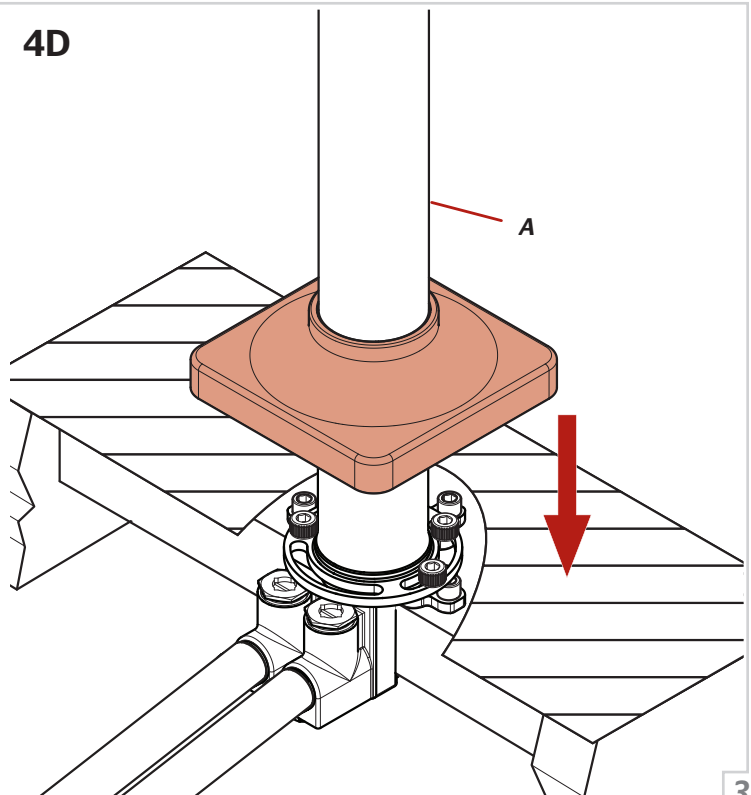

# 5

## Install Hand shower

Instale la ducha de mano

Installez la douchette

No Tools Required for This Step  
No se necesitan herramientas para este paso  
Aucun outil n'est nécessaire pour cette étape



B



C

5A

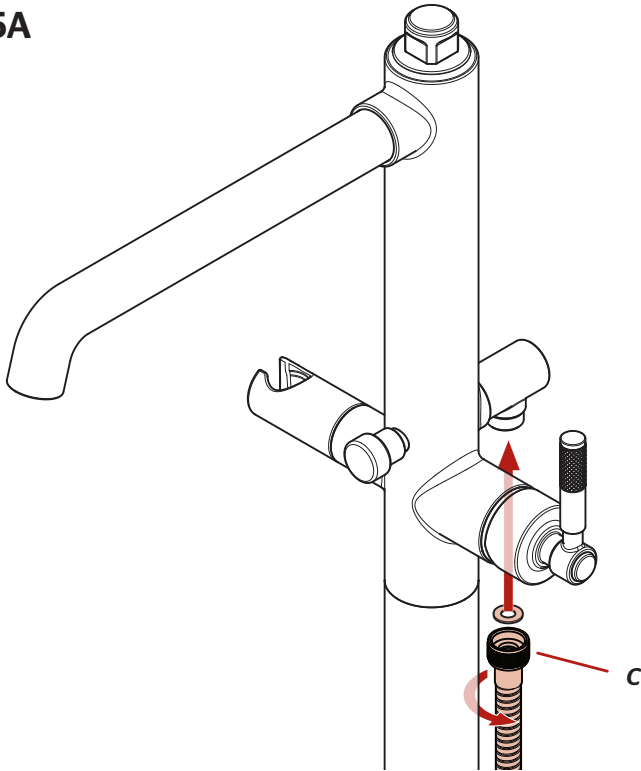

5C

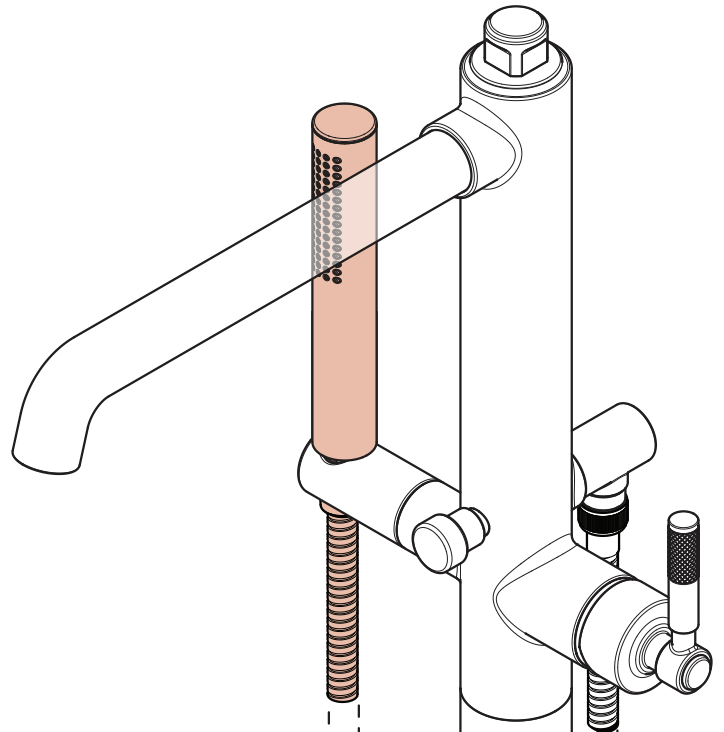

5B

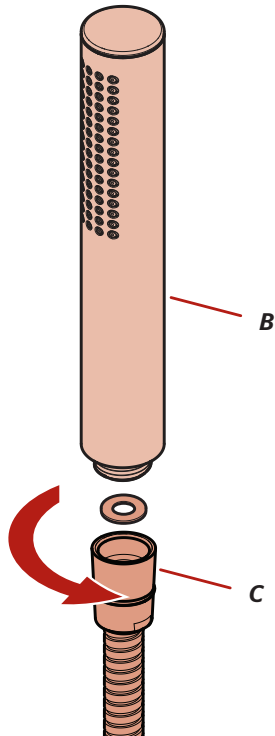

## 6 Turn On Water & Confirm Proper Installation

Active el suministro de agua y confirme que la instalación está adecuadamente efectuada  
Ouvrez l'eau et confirmez que l'installation est adéquate

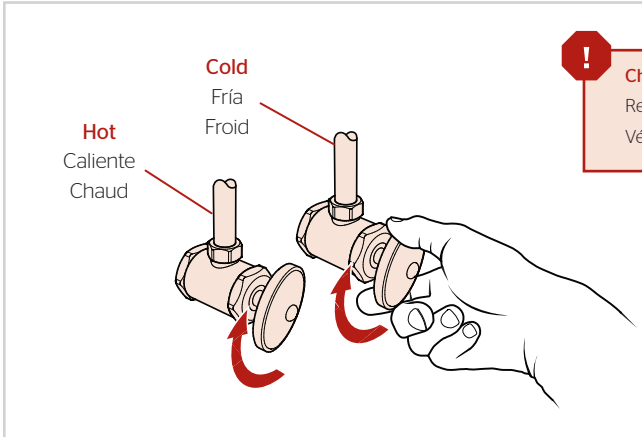

**!** **Check for leaks at water supply source.**  
Revise si hay fugas en la fuente de suministro de agua.  
Vérifier les fuites dans la source d'approvisionnement en eau.

## 7 Flush the Faucet

Enjuague el grifo  
Vidanger l'robinet

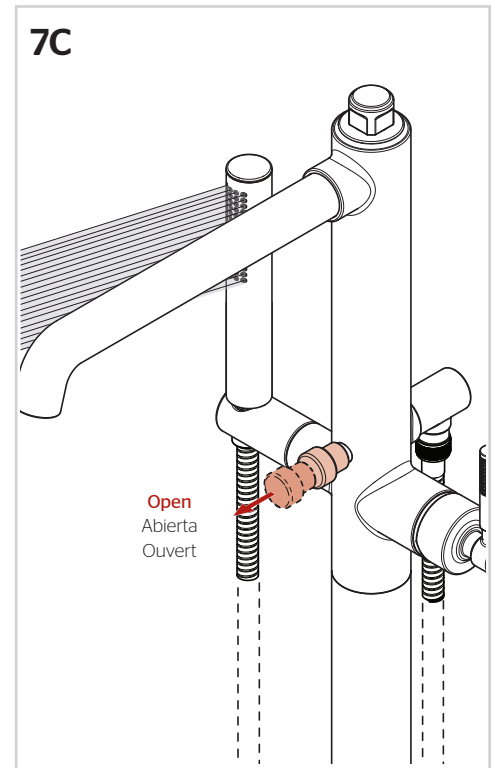
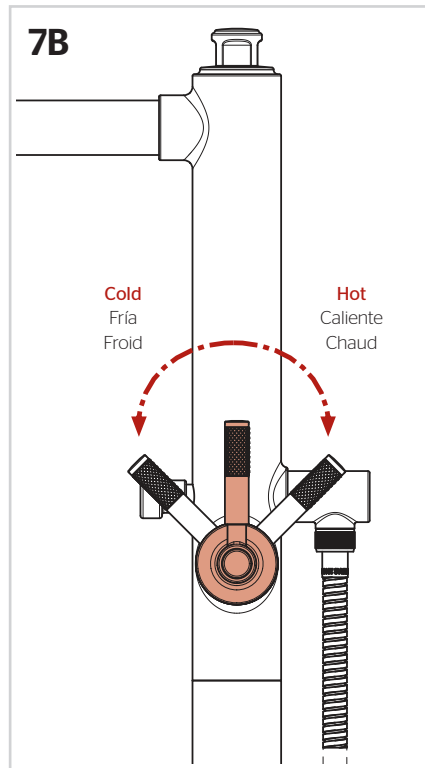
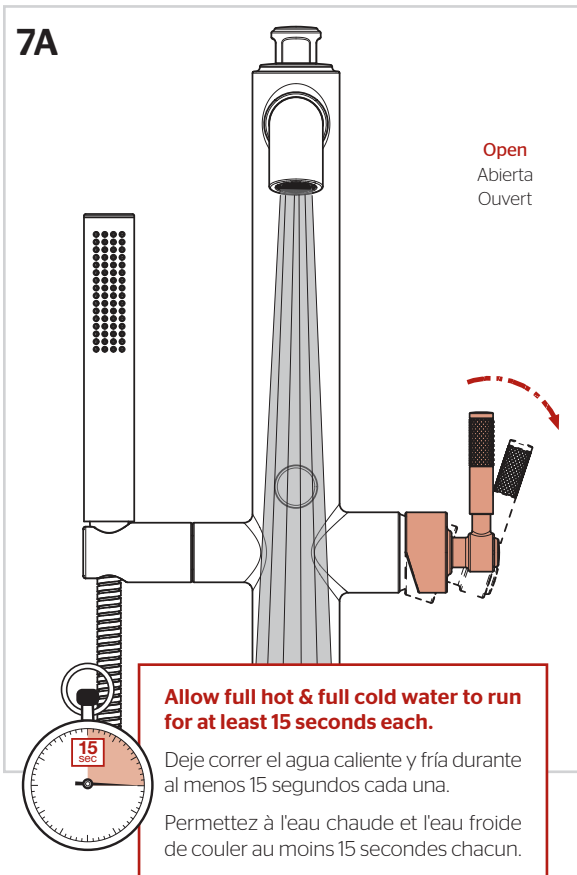

For Additional Installation Help:

Para la instalación adicionales de ayuda:

Pour aider à l'installation supplémentaires:

**Pfister**

1-800-PFAUCET (732-8238)  
pfisterfaucets.com