

PFBKIT03

COLLISTON TWO-HANDLE LAVATORY FAUCET AND BATH ACCESSORY KIT



Product Features

- Ceramic disc cartridges
- Metal handles
- Requires 3-hole sink with 4" on-center
- Max flow rate: 1.2 gpm at 60 psi
- ADA compliant
- Certified to ASME A112.18.1 / CSA B125.1
- cUPC/IAPMO listed
- NSF/ANSI/CAN61: $Q \leq 1$
- WaterSense certified
- AB1953 certified



PFBKIT03

Model Numbers

PFBKIT03	Chrome
PFBKIT03ZBN	Brushed Nickel

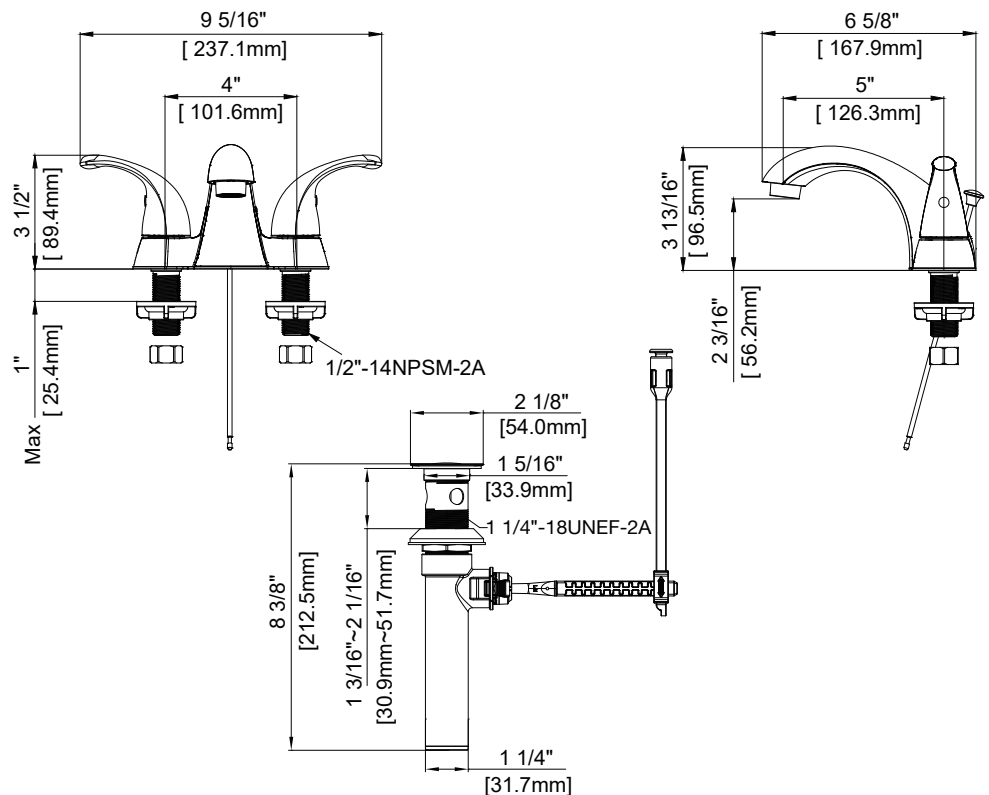

Warranty and Codes

This product comes complete with installation, operating, care and maintenance instructions. This PROFLO faucet carries a limited lifetime warranty when installed in residential applications. The warranty is five years in commercial applications.

*Compliant with lead content requirements of California AB1953



NSF/ANSI/CAN 372
NSF/ANSI/CAN 61-9 Q=1



PFBKIT03

COLLISTON TWO-HANDLE LAVATORY FAUCET AND BATH ACCESSORY KIT



Product Features

- Ceramic disc cartridges
- Metal handles
- Requires 3-hole sink with 4" on-center
- Max flow rate: 1.2 gpm at 60 psi
- ADA compliant
- Certified to ASME A112.18.1 / CSA B125.1
- cUPC/IAPMO listed
- NSF/ANSI/CAN61: $Q \leq 1$
- WaterSense certified
- AB1953 certified



PFBKIT03

Model Numbers

PFBKIT03	Chrome
PFBKIT03ZBN	Brushed Nickel

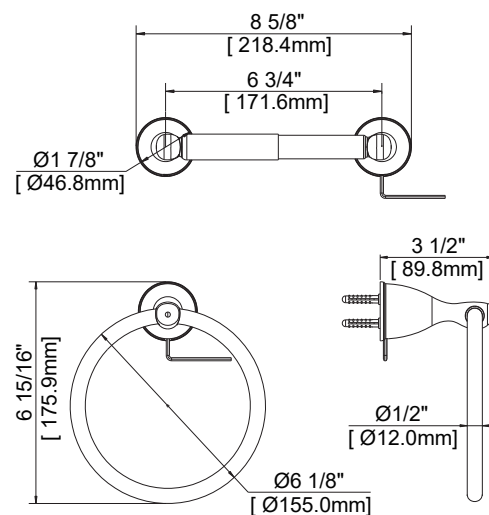
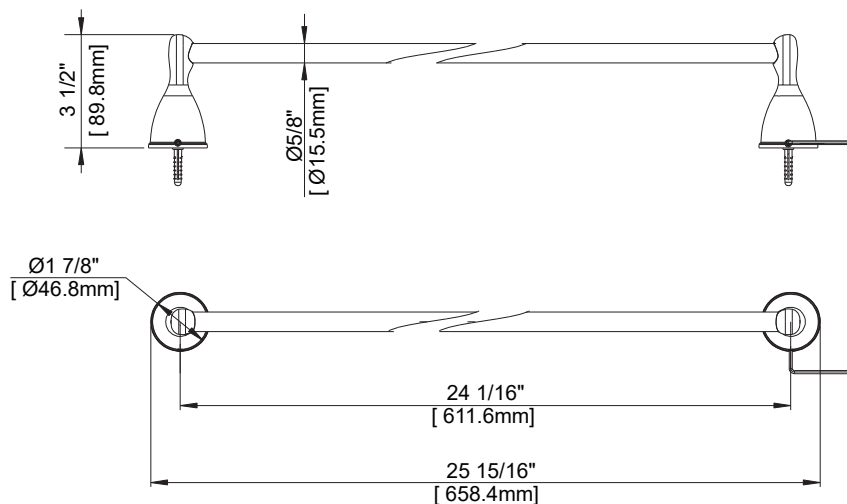

Warranty and Codes

This product comes complete with installation, operating, care and maintenance instructions. This PROFLO faucet carries a limited lifetime warranty when installed in residential applications. The warranty is five years in commercial applications.

*Compliant with lead content requirements of California AB1953



NSF/ANSI/CAN 372
NSF/ANSI/CAN 61-9 Qs1

