



Product Catalog

# Packaged Rooftop Air Conditioners Precedent™ Cooling and Gas/ Electric

3 to 10 Tons - 60 Hz





# Introduction

## Packaged Rooftop Air Conditioners

Trane's customers demand products that provide exceptional reliability, meet stringent performance requirements, and are competitively priced. Trane delivers with Precedent™.

Precedent™ features cutting edge technologies: reliable compressors, Trane engineered ReliaTel™ controls, computer-aided run testing, and Integrated Comfort™ Systems. So, whether you're the contractor, the engineer, or the owner you can be certain Precedent™ products are built to meet your needs.

Through the years, Trane has designed and developed the most complete line of Packaged Rooftop products available in the market today. Trane was the first to introduce the Micro—microelectronic unit controls—and has continued to improve and revolutionize this design concept.

Electromechanical controls are available for simpler applications, and for the more sophisticated, ReliaTel™ microprocessor controls.

The ReliaTel™ control platform offers the same great features and functionality as the original Micro, with additional benefits for greater application flexibility.

With its sleek, compact cabinet, Precedent™ continues to provide the highest standards in quality and reliability, comfort, ease of service, and the performance of Trane light commercial products.

## Copyright

This document and the information in it are the property of Trane, and may not be used or reproduced in whole or in part without written permission. Trane reserves the right to revise this publication at any time, and to make changes to its content without obligation to notify any person of such revision or change.

## Trademarks

All trademarks referenced in this document are the trademarks of their respective owners.

## Revision History

- Running edits included.
- Added Outside Air Measuring/Monitoring Control (TraQ Dampers) information in Precedent™ features – standard and optional table in Features and Benefits chapter.
- Added Outside Air Measuring/Monitoring Control (TraQ Dampers) section in Features and Benefits chapter.
- Removed VariTrac - Changeover Bypass System section in Features and Benefits chapter.
- Removed Cooling and gas/electric – 7.5 (dual compressor) to 10 tons standard efficiency, 6 to 8.5 tons high efficiency – power exhaust figure in Dimensional Data chapter.
- Removed VariTrac® section in Application Considerations chapter.
- Added TraQ Dampers in Factory installed options (fiops)/accessory net weights (lbs) table in Weights chapter.
- Added Outside Air Measuring/Monitoring (TraQ Dampers) section in Mechanical Specifications chapter.



# Table of Contents

Features and Benefits.....	5
Standard Features .....	7
Factory Installed Options .....	10
Factory or Field Installed Options.....	15
Field Installed Options.....	16
Other Benefits .....	17
Application Considerations .....	20
Barometric Relief .....	20
Black Epoxy Coil .....	20
Clearance Requirements .....	20
CompleteCoat™ Condenser Coil .....	20
Condensate Trap .....	21
Heating Operation .....	21
Low Airflow Operation .....	21
Low Ambient Cooling .....	21
Optional Stainless Steel Heat Exchanger.....	21
Unit Pitch .....	21
Selection Procedure .....	22
Cooling Capacity.....	22
Heating Capacity.....	23
Air Delivery Selection .....	23
Dehumidification Selection .....	23
Model Number Description .....	26
General Data.....	30
Gross Cooling Capacities .....	40
Direct Drive - Evaporator Fan Performance .....	70
Evaporator Fan Performance — Standard Efficiency .....	88
Evaporator Fan Performance — High Efficiency.....	132
Fan Performance .....	180
Heating Performance .....	185



## Table of Contents

---

Controls .....	190
ReliaTel™ .....	190
Economizer Controls .....	190
Differential Pressure Switches .....	192
RA Remote Sensor .....	193
Room Remote Sensor .....	193
Communication Interfaces .....	193
Electrical Data .....	194
Jobsite Connections .....	205
Dimensional Data.....	206
Weights.....	218
Mechanical Specifications .....	220
Standard .....	220
Factory Installed Options .....	222
Factory or Field Installed Options.....	225
Field Installed Options.....	226



# Features and Benefits

**Table 1. Precedent™ features – standard and optional**

	Standard Features	Options <sup>(a)</sup>		
		Factory Installed	Factory or Field Installed	Field Installed
1-year Limited Parts Warranty	X			
5-year Limited Compressor Warranty	X			
5-year Limited Heat Exchanger Compressor Warranty	X			
10-year Warranty Stainless Steel Heat Exchanger		X		
2" MERV 8 Filters or 2" MERV 13 Filters with Filter Removal Tool		X		
Anti-Short Cycle Timer (Standard with ReliaTel™)	X			
Belt Drive Motors <sup>(b)</sup>	X			
Black Epoxy Pre-Coated Coils <sup>(c)</sup>		X		
Barometric Relief			X	
CO <sub>2</sub> Sensor (wiring only)		X		
CO <sub>2</sub> Sensor <sup>(d)</sup>				X
Clogged Filter/Fan Failure Switch			X	
CompleteCoat™ Condenser Coil		X		
Condensate Overflow Switch		X		
Condenser Coil	X			
Convertible Airflow	X			
Colored and Numbered Wiring	X			
Cooling (Standard or High Efficiency)	X			
Crankcase Heaters	X			
Demand Control Ventilation			X	
Dehumidification Option		X		
Direct Drive Plenum Fan <sup>(e)</sup>	X	X		
Discharge Air Temperature Sensing Kit			X	
Easy Access Low Voltage Terminal Board (LTB)	X			
Economizer: Standard			X	
Economizer: Low Leak				X
Electric Heaters			X	
Fault Detection & Diagnostics (FDD); Meets CA Title 24 Requirements		X		
Filters	X			
Foil-Faced and Edge Captured Insulation	X			
Frostat™			X	
Hail Guards			X	
Heat Exchanger	X			
High Pressure Control	X			
Hinged Access Doors		X		
High Altitude Kit				X
High Static Drive				X
IAQ Dual Sloped, Plastic, Removable and Removable Drain Pan	X			
Liquid Line Refrigerant Drier	X			
Low Ambient Cooling to 0°F on Microprocessor Models	X			
Low Ambient Cooling to 40°F on Electromechanical Models	X			
Low Pressure Control	X			
Low Voltage Connections	X			
LP Conversion Kit				X



## Features and Benefits

**Table 1. Precedent™ features – standard and optional (continued)**

	Standard Features	Options <sup>(a)</sup>		
		Factory Installed	Factory or Field Installed	Field Installed
Manual Outside Air Damper				X
Microchannel Coils <sup>(f)</sup>	X			
Motorized Outside Air Damper				X
Multispeed Direct Drive Motors	X			
Multispeed Indoor Fan System		X		
Multiple Zone VAV (Variable Air Volume)		X		
Operating Charge of R-410A	X			
Outside Air Measuring/Monitoring Control (TraQ Dampers)				X
Phase Balance/Loss/Reversal Protection	X			
Phase Monitor	X			
Powered Exhaust				X
Powered or Unpowered Convenience Outlet		X		
Provisions for Through-the-Base Gas and Condensate Drain Connections	X			
Quick Adapt Curbs				X
Quick Access Panels	X			
Quick Adjust Fan Motor Mounting Plate	X			
Quick Start Kit				X
Reference or Comparative Enthalpy			X	
Remote Potentiometer				X
Roof Curb				X
Single Point Power	X			
Single Side Service	X			
Single Zone Variable Air Volume (SZVAV)		X		
Stainless Steel Drain Pan		X		
Standardized Components	X			
Supply, Return or Plenum Air Smoke Detector		X		
Thermal Expansion Valve	X			
Through-the-Base Condensate	X			
Through-the-Base Electrical Access		X		
Through-the-Base Electrical with Circuit Breaker		X		
Through-the-Base Electrical with Disconnect Switch		X		
Ventilation Override Accessory				X
Vibration Isolators				X

<sup>(a)</sup> Refer to model number description for option availability.

<sup>(b)</sup> Option on 3 to 5 ton high efficiency units.

<sup>(c)</sup> Not available on microchannel coils.

<sup>(d)</sup> CO<sub>2</sub> sensor associated with demand control ventilation always field installed.

<sup>(e)</sup> Standard on: (T/Y)SC120H, (T/Y)HC074, 092,102F, (T/Y)HC120F. Optional on: (T/Y)SC092–102H.

<sup>(f)</sup> The microchannel type condenser coil is standard for T/YSC(072,090,092,102,120)H, T/YHC(048,060,072,074, 092,102,120)F and (T/Y)SC (036,048,060)G models.

**Table 2. Precedent™ control options — standard and optional**

	Standard Features	Options <sup>(a)</sup>		
		Factory Installed	Factory or Field Installed	Field Installed
Dual Thermistor Remote Zone Sensor				X
Electromechanical or ReliaTel™ Microprocessor Controls	X			
Human Interface		X		
Humidity Sensor/Humidistat				X
Thermostat				X
Wireless Zone Sensor				X
Zone Sensor				X
BACnet® Communication Interface (BCI)			X	
LonTalk® Communication Interface (LCI)			X	
Trane® Air-Fi® Wireless Communication Interface		X		
Trane® Communication Interface			X	

**Note:** For more information, reference the Controls chapter.

<sup>(a)</sup> Refer to model number description for option availability.

## Standard Features

### Anti-Short Cycle Timer

Provides a 3 minute minimum “ON” time and 3 minute “OFF” time for compressors to enhance compressor reliability by assuring proper oil return.

### Colored And Numbered Wiring

Save time and money tracing wires and diagnosing the unit.

### Compressors

Precedent™ contains the best compressor technology available to achieve the highest possible performance. Dual compressors are outstanding for humidity control, light load cooling conditions and system back-up applications. Dual compressors are available on 6 to 10 tons models and allow for efficient cooling utilizing 3-stages of compressor operation (high efficiency models only).

### Condenser Coil

Precedent™ boasts a patent-pending 1+1+1 condenser coil, permanently gapped for easy cleaning.



### Controls — ReliaTel™ or Electromechanical

ReliaTel™ microprocessor controls provide unit control for heating, cooling and ventilating utilizing input from sensors that measure indoor and outdoor temperature and other zone



## Features and Benefits

---

sensors. ReliaTel™ also provides outputs for building automation systems and expanded diagnostics. For a complete list of ReliaTel™ offerings, refer to the “Other Benefits” section within the Features and Benefits section of this catalog.

For the simpler job that does not require a building automation system, or expanded diagnostics capabilities, Precedent™ offers electromechanical controls. This 24-volt control includes the control transformer and contactor pressure lugs for power wiring.

### Convertible Units

Units ship in a downflow configuration and can be easily converted to horizontal by simply moving two panels.

Units come complete with horizontal duct flanges so the contractor doesn't have to field fabricate them. These duct flanges are a time and cost saver.



### Crankcase Heaters

These band heaters provide improved compressor reliability by warming the oil to prevent migration during off-cycles or low ambient conditions.

### Direct Drive Motors

For additional static requirements, single-phase units offer multi-speed, direct drive motors. All 10 ton units and 6 to 8.5 ton high efficiency units offer variable speed direct drive motors.

### Direct Drive Plenum Fan

The following units are equipped with a direct drive plenum fan design (all 10 ton units, 6 (074) to 8.5 ton high efficiency units, and optional on 7.5 (092) to 8.5 ton standard efficiency units). Plenum fan design includes a backward-curved fan wheel along with an external rotor direct drive variable speed indoor motor. All plenum fan designs have a variable speed adjustment potentiometer located in the control box.

**Note:** Standard on: (T/Y)SC120H, (T/Y)HC074, 092, 102F, (T/Y)HC120F. Optional on (T/Y)SC092, 102H.

### Drain Pan

Every Precedent™ unit has a plastic, removable, dual-sloped drain pan (IAQ) that's easy to clean and reversible to allow installation of drain trap on either side of the unit.





## Easy Access Low Voltage Terminal Board

The low voltage terminal board is external to the electrical control cabinet. It is extremely easy to locate and attach the thermostat wire and test operation of all unit functions. This is another cost and time saving installation feature.

## Foil Faced and Edge Captured Insulation

All panels in the evaporator section of the unit have cleanable foil-faced insulation. All edges are either captured or sealed to ensure no insulation fibers get into the airstream.

## Heat Exchanger

The compact cabinet features a progressive tubular heat exchanger in low, medium and high heat capacities.

The heat exchanger is fabricated using corrosion-resistant aluminized steel tubes and burners as standard on all models. It has an induced draft blower to pull the gas mixture through the burner tubes. The heater has a direct spark ignition system which doubles as a safety device to prove the flame.

## Low Ambient Cooling

All Precedent™ microprocessor units have cooling capabilities down to 0°F as standard. Electromechanical models have cooling capabilities to 40°F as built, or to 0°F by adding the optional low ambient control (Frostat™).

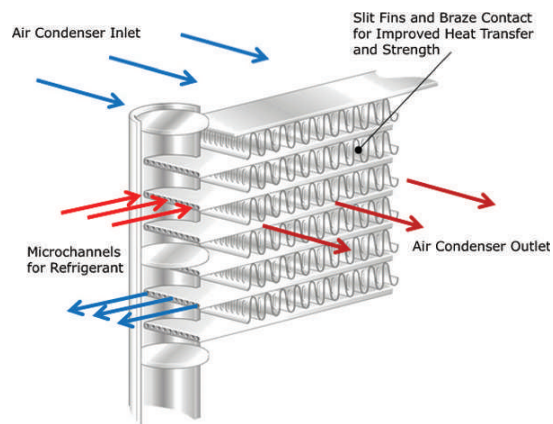
## Low Voltage Connections

The wiring of the low voltage connections to the unit and the zone sensors is as simple as 1-1, 2-2, and 3-3. This simplified system makes it easy for the installer to wire.

## Microchannel Condenser Coil

Microchannel condensing coils are all-aluminum coils with fully-brazed construction. This design reduces risk of leaks and provides increased coil rigidity — making them more rugged on the jobsite. Their flat streamlined tubes with small ports and metallurgical tube-to-fin bond allow for exceptional heat transfer. Microchannel all-aluminum construction provides several additional benefits:

- Light weight (simplifies coil handling)
- Easy to recycle
- Minimize galvanic corrosion





## Features and Benefits

---

### Phase Monitoring Protection

Precedent™ units with 3-phase power are equipped with phase monitoring protection as standard. These devices protect motors and compressors against problems caused by phase loss, phase imbalance and phase reversal indication.

### Quick Access Panels

Remove two screws for access to the standardized internal components and wiring.

### Standardized Components

Components are placed in the same location on all units. Due to standardized components throughout the line, contractors/owners can stock fewer parts.

### Through-the-Base Condensate

Every unit includes provisions for through-the-base condensate drain connections. This allows the drain to be connected through the roof curb instead of a roof penetration.

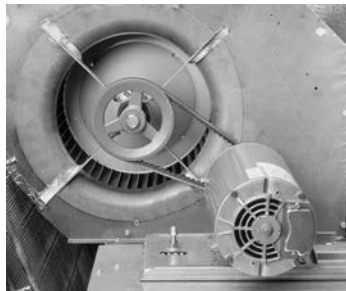
### Other Benefits

- Cabinet design ensures water integrity
- Ease of Service, Installation and Maintenance
- Mixed model build enables “fastest in the industry” ship cycle times
- Outstanding Airflow Distribution
- ReliaTel™ Controls

## Factory Installed Options

### Belt Drive Motors

For additional static requirements, Precedent™ 3 to 5 tons, high efficiency (15 SEER) units offer an optional belt drive motor to meet a wide range of airflow needs.



*Note: Available for three-phase units only.*

### Black Epoxy Pre-Coated Coils

The pre-coated coils are an economical option for protection in mildly corrosive environments.

*Note: Not available on microchannel condenser coils.*

### Circuit Breaker

This option is a factory installed thermal magnetic, molded case, HACR circuit breaker with provisions for through-the-base electrical connections.

*Note: Available on units equipped with through-the-base electrical.*



## Disconnect Switch

**Note:** Available on units equipped with through-the-base electrical.

Factory installed 3-pole, molded case, disconnect switch for through-the-base electrical connections.

Codes require a method of assured unit shutdown for servicing. Field-installed disconnects sometimes interfere with service access. Factory installation of unit disconnects reduces costs, assures proper mounting and provides the opportunity to upgrade to unit circuit breaker protection.

## Convenience Outlet

This option is a GFCI, 120V/15amp, 2 plug, convenience outlet, either powered or unpowered. This option can only be ordered when through-the-base electrical with either the disconnect switch or circuit breaker option is ordered.



**Note:** Convenience outlet not available on 575V units or 3 to 5 ton high efficiency units with direct drive indoor motor.

## CO<sub>2</sub> Sensor Wiring

This is the unit wiring for field installed CO<sub>2</sub> sensors. Factory-installed CO<sub>2</sub> sensor wiring saves time and ensures proper unit connections for the field installed CO<sub>2</sub> sensor kits.

## CompleteCoat™ Condenser Coil

These coils provide excellent corrosion resistance as well as uniformity of coverage and coating thickness. This option is available for both fin-tube and microchannel condenser coils.

## Condensate Overflow Switch

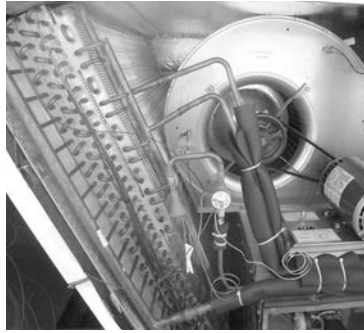
A condensate overflow switch is available to shut the unit down in the event that the condensate drain becomes clogged. This option protects the unit from water overflowing from the drain pan and entering the base of the unit.

## Dehumidification (Hot Gas Reheat)

This option allows for increased outdoor air ventilation. It reduces humidity levels while increasing comfort level in the air space. Cooling can operate without a demand for dehumidification. The hot gas reheat coil is designed to deliver maximum reheat temperatures.



## Features and Benefits



### Fault Detection and Diagnostics (FDD)

This offering meets the mandatory requirement of CA Title 24 of fully configurable diagnostics allowing fault history and reading fault codes at the unit. This option provides detection of the following faults: Air temperature sensor failure/fault and notification of acceptable economizer mode. The FDD system shall be certified by the Energy Commission as meeting the requirements.

### Human Interface



The 5 inch color touchscreen human interface provides an intuitive user interface to the rooftop unit that speeds up unit commissioning, shortens unit troubleshooting times, and enhances preventative maintenance measures. The human interface includes several features such as:

- Data trending capabilities by means of time series graphs
- Historical alarm messages
- Real-time sensor measurements
- On board system setpoints
- USB port that enables the downloading of component runtime information as well as trended historical sensor data
- Customized reports

**Note:** Refer to RT-SVX49\*-EN for additional information.

### High Efficiency Filtration

Precedent™ units offer a variety of high efficiency filtration options. MERV 8 and MERV 13 filters provide additional filtration beyond the capabilities of typical 2" throwaway filters. Also, when MERV 8 or MERV 13 filters are ordered, units come equipped with a filter removal tool.

## Hinged Access Doors

These doors permit easy access to the filter, fan/heat and compressor/control sections. They reduce the potential roof damage from screws or sharp access door corners.



## Multi-Speed Indoor Fan System

Multi-speed indoor fan system is designed for use in applications for meeting the minimum requirement of CA Title 24.

This system incorporates a multi-speed fan control to change the speed of the fan to 66% of full airflow based off of compressor stages.

## Multiple-Zone VAV Control

A multiple-zone VAV (MZVAV) system consists of a packaged rooftop unit that serves several individually controlled zones. Each zone is equipped with a VAV terminal unit that varies the quantity of air delivered to maintain the desired temperature in that zone. The rooftop unit controller varies the speed of the indoor fan to maintain the static pressure in the supply ductwork at a setpoint, ensuring that all zones receive the necessary quantity of air. In addition, cooling capacity is cycled to maintain the supply air temperature at the desired setpoint.

For decades, Trane has been an industry leader in rooftop VAV systems. Now, multiple-zone VAV control is available in the light commercial rooftop platform (3 to 25 tons).

## Novar Unit Controls

Novar 3051 and 2024 are available for Precedent™ gas and electric heat models.

## Single Zone VAV (SZVAV)

Single Zone VAV (SZVAV) is designed for use in single zone applications such as gymnasiums, auditoriums, manufacturing facilities, retail box stores, and any large open spaces where there is a diversity in the load profile. It is an ideal replacement to "yesterday's" constant-volume (CV) systems, as it reduces operating costs while improving occupant comfort.

SZVAV systems combine Trane application, control and system integration knowledge to exactly match fan speed with cooling and heating loads, regardless of the operating condition. Trane algorithms meet and/or exceed ASHRAE 90.1 SZVAV energy-saving recommendations and those of CA Title 24. The result is an optimized balance between zone temperature control and system energy savings. Depending on your specific application, energy savings can be as much as 20+%.

**Note:** *Building system modeling in energy simulation software such as TRACE is recommended to evaluate performance improvements for your application.*

SZVAV is fully integrated into the control system. It provides the simplest and fastest commissioning in the industry through proven factory-installed, wired, and tested system controllers. All control modules, logic boards and sensors are factory installed and tested to ensure the highest quality and most reliable system available. This means no special programming of algorithms, or hunting at the jobsite for field installed sensors, boards, etc. SZVAV is a quick and simple solution for many applications and is available from your most trusted rooftop VAV system solution provider -Trane.

**Note:** *Only available on 7.5 to 20 tons units.*



## Features and Benefits

---

### Stainless Steel Drain Pan

For excellent corrosion and oxidation resistance, the optional stainless steel drain pan provides a cleanable surface that complement other IAQ solutions such as high efficiency filtration (MERV 8 or 13), demand control ventilation (CO<sub>2</sub>), and hot gas reheat.

### Stainless Steel Heat Exchanger

The optional stainless steel heat exchanger is constructed of 409 stainless steel tubes and 439 stainless steel burners. It is resistant to corrosion and oxidation and easy to clean. The high strength to weight ratio allows for high ventilation rates with gas units. It is an excellent option to compliment the dehumidification option as a high outside air ventilation unit. With this option, a 10-year stainless steel heat exchanger warranty is standard.

### Supply, Return, and Plenum Air Smoke Detector

With this option installed, if smoke is detected, all unit operation will be shut down. Reset will be manual at the unit. In order for the supply air smoke detector or return air smoke detector to properly sense smoke in the supply air stream or the return air stream, the air velocity entering the smoke detector unit must be between 500 - 4000 feet per minute. Equipment covered in this manual will develop an airflow velocity that falls within these limits over the entire airflow range specified in the evaporator fan performance table. Supply and/or return smoke detectors may not be used with the plenum smoke detector.

Figure 1. Supply/Return air smoke detector



Figure 2. Plenum Air Smoke Detector



*Note: Plenum smoke detectors have no auxiliary contacts for external connections.*

### Through-the-Base Gas Access

Factory provided through-the-base openings simplify wiring and piping. Because these utility openings frequently minimize the number of roof penetrations, the integrity of roofing materials is enhanced.



### Through-the-Base Electrical Access

An electrical service entrance shall be provided allowing electrical access for both control and main power connections inside the curb and through-the-base of the unit. Option will allow for field installation of liquid-tight conduit and an external field installed disconnect switch.



## Factory or Field Installed Options

### Barometric Relief

Designed to be used on downflow units, barometric relief is an unpowered means of relieving excess building pressure.

### Clogged Filter/Fan Failure Switch

A dedicated differential pressure switch is available to achieve active fan failure indication and/or clogged filter indication.

These sensors allow a zone sensor service light or Integrated Comfort System to indicate a dirty filter or a fan that's not working. The field installation charges for these valuable feedback devices often eliminate them from consideration. Factory installation can make such features a good investment.

### Discharge Air Temperature Sensing Kit

Provides true discharge air temperature sensing in heating models. This sensor is a status indicator readable through Tracer® or Tracker™. The kit is functional only with the ReliaTel™ options module.

### Economizer (Standard)

This standard economizer accessory shall be available with or without barometric relief. The assembly includes fully modulating 0-100 percent motor and dampers, minimum position setting, preset linkage, wiring harness with plug, spring return actuator and fixed dry bulb control. The barometric relief shall provide a pressure operated damper that shall be gravity closing and shall prohibit entrance of outside air during the equipment "off" cycle. Optional solid state or differential enthalpy control shall be available for either factory or field installation. The economizer arrives in the shipping position and shall be moved to the operating position by the installing contractor.

### Electric Heaters

Electric heat modules are available within the basic unit. If ordering the through-the-base electrical option with an electrical heater, the heater must be factory installed.

### Fresh Air — Dampers and Economizer

0 - 25% manual or 0 - 50% motorized outside air hoods are available.

Economizers are equipped with either dry bulb or reference or comparative enthalpy sensing. These economizers provide free cooling as the outdoor temperature and/or humidity decreases. Correctly installed, they offer a valuable energy savings. Factory-installed economizers save time and ensure proper installation.

### Frostat™

This capillary bulb embedded in the face of the evaporator coil or thermostat on the suction line monitors coil temperature to prevent evaporator icing and protect the compressor.



## Features and Benefits

---

Recommended for applications with low leaving air temperatures, low airflow and or high latent load applications.

**Note:** Froststat™ is standard on all single-zone and multiple-zone VAV models.

### Hail Guards

Hail protection quality coil guards protects the condenser coil from vandalism and/or hail damage.

### Low Leak Economizer

This accessory meets low leak requirements for ASHRAE 90.1, IECC, and CA Title 24 standards (4 cfm/ft<sup>2</sup>@1" wg exterior air/return air). This option allows 100% outdoor air supply from 0-100% modulating dampers and is standard with barometric relief. It can be paired with powered exhaust for additional building pressure relief. This option can be paired with or without fault detection & diagnostics (FDD) to meet current mandatory CA Title 24 requirements.

The economizers come with three control options, dry bulb and reference or comparative enthalpy (optional).

**Note:** Low leak economizers available on downflow units only.

### Reference or Comparative Enthalpy

Measures and communicates humidity while maximizing comfort control.

## Field Installed Options

### CO<sub>2</sub> Sensor — Demand Control Ventilation (DCV)

Demand-controlled ventilation (DCV) is a control strategy that responds to the actual demand (need) for ventilation by regulating the rate at which the HVAC system brings outdoor air into the building. A CO<sub>2</sub> sensor measures the concentration (parts per million, ppm) of CO<sub>2</sub> (carbon dioxide) in the air. As the CO<sub>2</sub> concentration changes, the outside air damper modulates to meet the current ventilation needs of the zone. The CO<sub>2</sub> sensor kit is available as a field installed accessory. Two field installed kits are offered; CO<sub>2</sub> sensor and wiring or CO<sub>2</sub> sensor only. The CO<sub>2</sub> Sensor only kit should be ordered with factory installed CO<sub>2</sub> sensor wiring. Factory installed CO<sub>2</sub> sensor wiring saves set-up time and ensures proper unit connections for the CO<sub>2</sub> sensor.

### High Altitude Kit

While recommended for units applied above 2,000 feet, domestic contractors should consult with local authority on best practice. High altitude kits contain gas orifices that derate the gas input rate (Btuh/r) by 10%.

### High Static Drive

Available on many models, this high static drive accessory extends the capability of the standard motor. Avoid expensive motors and operating costs by installing this optimized sheave accessory.

### Humidity Sensor/Humidistat

The humidity sensor/humidistat, when used in conjunction with our dehumidification (hot gas reheat) units will provide outstanding humidity control and comfort. Humidity sensors can be wall or duct mounted. The humidity deadband can be set between 40% and 60% relative humidity.

### Low Leak Economizer — Field Installed

This accessory meets low leak requirements for ASHRAE 90.1, IECC, and CA Title 24 standards (4 cfm/ft<sup>2</sup>@1" wg exterior air/return air). This option allows 100% outdoor air supply from 0-100% modulating dampers and is standard with barometric relief. It can be paired with powered exhaust for additional building pressure relief.



*Note: Available on downflow units only.*

### **LP Conversion Kit**

Provided for field conversion of gas/electric units from natural gas to propane.

### **Outside Air Measuring/Monitoring Control (TraQ Dampers)**

Quantity of fresh air entering the unit will be measured and monitored via Trane UC400 controller and series of pressure sensing rings mounted at the outside air intake.

### **Quick Adapt Curbs**

Enables easy conversion of existing Voyager™ 3 to 10 ton units to Precedent™ units on replacement jobs.

### **Quick Start Kits**

Single phase equipment to enable startup and prevent building lighting dimming during low voltage.

### **Roof Curbs**

Available for downflow units. Only three roof curbs for the entire line simplifies curb selection.

### **Remote Potentiometer**

When properly installed in the economizer control circuitry, this accessory provides a remote variable resistance to enable the operator to adjust the minimum damper position.

### **Ventilation Override Accessory**

With the ventilation override accessory installed, the unit can be set to transition to up to 3 different pre-programmed sequences for smoke purge, pressurization, and exhaust. The transition occurs when a binary input on the RTOM is closed (shorted). This would typically be a hard wired relay output from a smoke detector or fire control panel. The ventilation override kit is available as a field installed accessory.

## **Other Benefits**

### **Airflow Distribution**

Airflow is outstanding. Precedent™ can replace an older machine with old ductwork and, in many cases, improve the comfort through better air distribution.

### **Cabinet Integrity**

For added water integrity, Precedent™ has a raised 1 1/8" lip around the supply and return of the downflow units to prevent water from blowing into the ductwork.

The compact cabinet with rounded corners takes up less room. The beveled and ribbed top is aesthetically pleasing and designed to prevent water from pooling.





## Features and Benefits

---

### Flexibility

Precedent™ offers ultimate flexibility. Units are built to order in our standard “shortest in the industry” ship cycle time.

### Rigorous Testing

All of the Precedent™ designs were rigorously rain tested at the factory to ensure water integrity. Actual shipping tests were performed to determine packaging requirements. Units were test shipped around the country to determine the best packaging design. Factory shake and drop tests were used as part of the package design process to help assure that the unit arrives at the job site in top condition.

Rigging tests include lifting a unit into the air and letting it drop one foot, assuring that the lifting lugs and rails hold up under stress.

We perform a 100% coil leak test at the factory. The evaporator and condenser coils are leak tested at 600 psig. The assembled unit is leak tested to 465 psig.

All parts are inspected at the point of final assembly. Sub-standard parts are identified and rejected immediately.

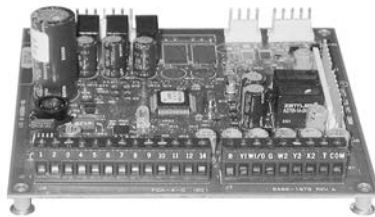
Every unit receives a 100% unit run test before leaving the production line to make sure it meets rigorous requirements.

### Easy to Install, Service and Maintain

Because today’s owners are very cost-conscious when it comes to service and maintenance, this unit was designed with direct input from service contractors. This valuable information helped to design a product that would get the service technician off the job quicker and save the owner money. This product line offers outstanding standard features enhanced by a variety of factory and field installed options, multiple control options, rigorously tested proven designs and superior product and technical support.

### ReliaTel™ Controls

Figure 3. ReliaTel board



ReliaTel controls provide unit control for heating, cooling, and ventilating, utilizing input from sensors that measure outdoor and indoor temperature. ReliaTel also provides outputs for building automation systems and expanded diagnostics. Quality and reliability are enhanced through ReliaTel control and logic:

- Prevents the unit from short cycling, considerably improving compressor life.
- Ensures the compressor will run for a specific amount of time which allows oil to return for better lubrication, enhancing the reliability of the compressor.
- Reduces the number of components required to operate the unit, reducing possibilities for component failure.

#### ReliaTel Makes Installing and Servicing Easy

ReliaTel eliminates the need for field-installed, anti-short cycle timer and time delay relays. The wiring of the low voltage connections to the unit and the zone sensors is as easy as 1-1, 2-2, and 3-3. This simplified system makes wiring easier for the installer.

### **ReliaTel Makes Testing Easy**

ReliaTel requires no special tools to run the unit through its paces. Simply place a jumper between Test 1 and Test 2 terminals on the Low Voltage Terminal Board and the unit will walk through its operational steps automatically. The unit automatically returns control to the zone sensor after stepping through the test mode a single time, even if the jumper is left on the unit. As long as the unit has power and the "system on" LED is lit, ReliaTel is operational. The light indicates that the controls are functioning properly. ReliaTel features expanded diagnostic capabilities when utilized with Trane Integrated Comfort™ Systems. Some zone sensor options have central control panel lights which indicate the mode the unit is in and possible diagnostic information (dirty filters for example).

### **ReliaTel Has Other Benefits**

- The ReliaTel built-in anti-shortcycle timer, time delay relay and minimum "on" time control functions are factory tested to assure proper operation.
- ReliaTel softens electrical "spikes" by staging on fans, compressors and heaters.
- Intelligent Fallback is a benefit to the building occupant. If a component goes astray, the unit will continue to operate at predetermined temperature setpoint.
- Intelligent Anticipation is a standard feature. It functions continuously as ReliaTel and zone sensor(s) work together in harmony to provide much tighter comfort control than conventional electromechanical thermostats.
- The ReliaTel design is standardized across the board, ensuring a lower cost to owners.



# Application Considerations

Application of this product should be within the cataloged airflow and cooling considerations.

## Barometric Relief

This product line offers an optional barometric relief damper for use in conjunction with economizer option. This accessory consists of gravity dampers which open with increased pressure. As the building air pressure increases, the pressure in the unit return air section also increases, opening the dampers and relieving the conditioned space.

**Note:** *The effectiveness of barometric relief damper during economizing operation is limited, depending on the pressure drop of the return-air path. For some applications, powered exhaust may be better suited for preventing over-pressurization when economizing.*

## Black Epoxy Coil

The coils are manufactured with a thermoset, vinyl coating that is bonded to the aluminum fin stock prior to the fin stamping process. These coils are an economical option for protection in mildly corrosive environments.

**Notes:**

- *Not to be used where seacoast applications exist.*
- *Not available on microchannel condenser coils.*

## Clearance Requirements

The recommended clearances identified with unit dimensions should be maintained to assure adequate service maximum capacity and peak operating efficiency. Actual clearances which appear inadequate should be reviewed with the local Trane sales personnel.

Model Number	Clearance required from duct to combustible surfaces (inches)
TSC036G	0
THC036E	1
TSC048G	0
THC048E,F	0
TSC060G	0
THC060E,F	0
TSC072H	0
THC072F	1
THC074F	1
TSC090H	1
TSC092H	0
THC092F	1
TSC102H	0
THC102F	1
TSC120H	1
THC120F	1

## CompleteCoat™ Condenser Coil

The coils provide protection from corrosive environments and are ideal for seacoast applications.

## Condensate Trap

The evaporator is a draw-thru configuration. A trap must be field provided prior to start-up on the cooling cycle.

## Heating Operation

The heat exchanger is manufactured with aluminized steel. To prevent condensation within the heat exchanger, do not exceed 50% outside air or a minimum mixed air temperature of 40°F.

## Low Airflow Operation

Units equipped electric heat or staged gas heat may not be selected for supply airflow less than 320 cfm/ton. Cooling-only units can be used in applications designed for supply airflow below 320 cfm/ton. The units must be high-efficiency models with dehumidification (hot gas reheat) or be equipped with a TXV, Froststat™, and crankcase heaters.

Units selected with multiple-speed indoor fan control, single-zone VAV control, or multiple-zone VAV control are capable of operating at supply airflows below 320 cfm/ton at part-load conditions, but design (or "full") airflow must be set to 320 cfm/ton or higher.

## Low Ambient Cooling

The Precedent™ line features, with ReliaTel™ microprocessor controls, low ambient cooling down to 0°F. With electromechanical controls, Precedent™ features low ambient cooling to 40°F. The following features or options need to be included/considered when low ambient applications are required: continuous fan operation, crankcase heaters, thermal expansion valves, Froststat™.

Contact a local Trane representative for more assistance with low ambient cooling applications.

## Optional Stainless Steel Heat Exchanger

The optional stainless steel heat exchanger is manufactured with 409 stainless steel tubes and 439 stainless steel burners. To prevent corrosion and prolong heat exchanger reliability, the minimum mixed air temperature allowed across the heat exchanger is 20°F.

The stainless steel heat exchanger option is an excellent option that compliments the dehumidification package. Whenever high outside air or outside applications exist, these options should be utilized.

## Unit Pitch

The unit has a reversible sloped condensate drain pans. The unit must be installed level. Any unit slope must be toward the side of unit where condensate drain is connected.



# Selection Procedure

## Cooling Capacity

**Note:** Cooling capacity procedure is the same for electric heat (T\*C) and gas heat (Y\*C).

1. Calculate the total and sensible cooling loads for the building at design conditions. Use the Trane calculation methods or any other standard accepted method.

Factors used in unit selection:

- Packaged Cooling with Optional Electric Heat
- Total Cooling Load: 57 MBh
- Sensible Cooling Load: 40 MBh
- Airflow: 2000 cfm
- Electrical Characteristics: 460/60/3
- Summer Design Conditions: Entering Evaporator Coil: 80°F DB/67°F WB
- Outdoor Ambient: 95°F
- External Static Pressure: 0.34 in. wg
- Downflow Configuration
- Efficiency: 14 SEER
- Economizer

2. As a starting point, a rough determination must be made of the size of the unit. The final selection will be made after examining the performance at the given conditions. Divide the total cooling load by nominal Btuh per ton (12 MBh per ton); then round up to the nearest unit size.

59 MBh/12 MBh = approx. 5 tons

3. [Table 10, p. 40](#) shows that a TSC060G4 has a gross cooling capacity of 60 MBh and 49 MBh sensible capacity at 2000 cfm and 95°F DB outdoor ambient with 80°F DB, 67°F WB air entering the evaporator.

### Find capacity at intermediate conditions not in the table

When the design conditions are between two numbers that are in the capacity table, interpolation is required to approximate the capacity.

**Note:** Extrapolation outside of the table conditions is not recommended.

4. In order to select the correct unit which meets the building's requirements, the fan motor heat must be deducted from the gross cooling capacity. The amount of heat that the fan motor generates is dependent on the effort by the motor - cfm and static pressure. To determine the total unit static pressure take into account the following information.

External Static Duct System	0.34 wg
Standard Filter 2 in. from <a href="#">Table 148, p. 183</a>	0.06 wg
Economizer from <a href="#">Table 148, p. 183</a> (100% Outside Air) *worst case	0.18 wg
Electric Heater Size 6 kW from <a href="#">Table 154, p. 187</a>	0.06 wg
Total Static Pressure	0.64 wg

**Note:** Reference heating capacity section on this page for determination of heater size.

**Note:** The evaporator fan performance has deducted the pressure drop for a filter already in the unit. Therefore, the actual total static pressure is  $0.515 - 0.06 = 0.466$  wg.

With 2000 cfm and 0.47 wg, [p. 70](#) shows 0.58 bhp for this unit.

**Note:** Below the table is the formula to calculate fan motor heat.

$$2.87 \times \text{bhp} + 0.15 = \text{MBh}$$

$$2.87 \times 0.575 + 0.15 = 1.8 \text{ MBh}$$

Now subtract the fan motor heat from the gross cooling capacity of the unit:

$$\text{Net Total Cooling Capacity} = 60 \text{ MBh} - 1.8 = 58.2 \text{ MBh}$$

$$\text{Net Sensible Cooling Capacity} = 49 \text{ MBh} - 1.8 = 47.2 \text{ MBh}$$

Subtract sensible from total capacity to find latent capacity

$$\text{Net Latent Capacity} = 60.5 - 46.3 = 11 \text{ MBh}$$

5. Compare your resulting capacities to the building load. If the performance will not meet the required load of the building's total or sensible cooling load, try a selection at the next higher size unit.

## Heating Capacity

**Note:** Heating capacity procedure DIFFERS for electric heat (T°C) and gas heat (Y°C).

1. Calculate the heating loads for the building at design conditions. Use the Trane calculation methods or any other standard accepted method.
2. Size the system heating capacity to match the calculated building heating load. The following are building heating requirements:

Total heating load of 15 MBh

2000 cfm

T°C units with optional electric heat: 460V/3 phase power supply

A 6 kW heater will deliver 20.48 MBh at 480 volts. In order to determine capacity at 460 volts, the heater voltage correction factor must be used. Therefore, 20.48 MBh x 0.918 (voltage correction factor) = 18.8 MBh.

Y°C units with gas heat: Fuel - natural gas.

60 MBh, 80 MBh, 120 MBh, and 130 MBh input models.. The output capacities of these furnaces are 49.2 MBh, 65.6 MBh, 98.4 MBh, and 106.6 MBh respectively. The low heat model with 49.2 MBh best matches the building requirements.

## Air Delivery Selection

**Note:** Air delivery procedure is the same for electric heat and gas heat units.)

External static pressure drop through the air distribution system has been calculated to be 0.5 inches of water. For a TSC060G4 at 2000 cfm and 0.47 static pressure, the standard direct drive motor will give the desired airflow at a rated bhp of 0.58 and 924 rpm.

## Dehumidification Selection

**Note:** Dehumidification selection procedure is the same for both electric heat (THC) and gas heat (YHC) models.

Typical 5 ton THC060E	OA Conditions	RA conditions
2000 cfm Total Supply Airflow	Part load day and raining	75°F db
800 cfm Outside Air (40%)	68°F db	63°F wb
1200 cfm Return Air	67°F wb	
0.34" External Static Pressure	95% RH	

1. Determine the mixed/entering air condition (MA)

MA = (% outside air\*outside air dry-bulb temperature) + (% return air\*return air dry-bulb temperature)

## Selection Procedure

---

$$MA = (0.40 \times 68^\circ\text{F}) + (0.60 \times 75^\circ\text{F})$$

$$MA = 72.20^\circ\text{F db}$$

Repeat for wet-bulb temperature (wb)

$$MA = 72.2^\circ\text{F db}$$

$$64.6^\circ\text{F wb}$$

2. Determine the additional static pressure drop for a reheat unit.

Astatic pressure drop of 0.13" for the reheat coil and an additional 0.08 for the mandatory 2" pleated filters required when ordering the dehumidification option. Total static pressure = .34 + 0.08 + 0.13 = 0.55

**Note:** Do not forget to also add any additional static from other accessories. This selection does not include additional accessories.

A standard motor and drive is needed for this airflow and static pressure range.

3. Determine leaving *evaporator* temperature (SA')

$$\text{Leaving Evaporator Temperature} = SA'$$

Utilizing the manual **Cooling Capacity** selection method as previously described, find the leaving evaporator temperatures with the following formula:

$$\Delta \text{Temp} = \frac{\text{gross sensible or gross latent cooling capacity in Btuh}}{(\text{cfm}) (1.085)}$$

Subtract your sensible  $\Delta$  temp from the entering db and latent  $\Delta$  temp from the entering wb to determine the leaving evaporator db & wb (temperatures without the addition of fan heat).

$$52.7^\circ\text{F db}$$

$$52.7^\circ\text{F wb}$$

$$52.7^\circ\text{F dp}$$

4. Determine leaving *unit* temperature in standard cooling mode.

Repeat [Step 3](#). substituting **net** sensible or latent capacity for **gross** sensible or latent capacity to find the leaving unit temperature including fan heat.

$$53.7^\circ\text{F db}$$

$$53.1^\circ\text{F wb}$$

5. Determine reheat temperature rise.

Using the leaving *evaporator* temp (SA') determine the reheat temperature rise for that particular cfm: +/- 9.0°F db.

**Note:** Reheat temperature rise is based on **supply airflow** and leaving **evaporator coil** temperature.

6. Determine leaving unit sensible temperature *with reheat active* (SA)

$$\text{Reheat temperature (obtained in Step 5) + (SA' + fan heat) = SA}$$

**Note:** (SA' + fan heat) = leaving unit temperature in standard cooling mode from [Step 4](#).

$$19.0^\circ\text{F db} + 53.7^\circ\text{F} = 72.7^\circ\text{F db}$$

$$SA = 72.7^\circ\text{F}$$

Since reheat adds only sensible heat, the dewpoint temperature will remain constant so follow the dewpoint temperature line across the psychrometric chart to find the new wb temperature.

$$\pm 60.5^\circ\text{F wb}$$

$$52.7 \text{ dp}$$

$$49.9\% \text{ RH}$$



If the space relative humidity is equal to or above the space relative humidity setpoint, the dehumidification option will:

- Energize compressor or both compressors (2 stage compressor units).
- Hot gas reheat valve is energized and hot gas is diverted to the reheat coil.
- Dehumidification/reheat is terminated when space humidity is reduced to 5% below relative humidity setpoint.

At MA air enters the RTU. The RTU filters, cools, and dehumidifies the air as it moves through the evaporator coil. Air leaves the evaporator coil saturated at the preset dew point condition (SA') and is reheated by the hot gas reheat coil to deliver 72.7°F (SA) supply air to the space.



# Model Number Description

## Digit 1 — Unit Type

**T** = DX Cooling  
**Y** = DX Cooling, Gas Heat

## Digit 2 — Efficiency

**S** = Standard Efficiency  
**H** = High Efficiency

## Digit 3 — Airflow

**C** = Convertible

## Digit 4,5,6 — Nominal Gross Cooling Capacity (MBh)

**036** = 3 Ton  
**048** = 4 Ton  
**060** = 5 Ton  
**072** = 6 Ton  
**074** = 6 Ton, Dual Compressor  
**090** = 7.5 Ton, Single Compressor  
**092** = 7.5 Ton, Dual Compressor  
**102** = 8.5 Ton  
**120** = 10 Ton

## Digit 7 — Major Design Sequence

## Digit 8 — Voltage Selection

**3** = 208–230/60/3  
**4** = 460/60/3  
**W** = 575/60/3

## Digit 9 — Unit Controls

**E** = Electromechanical  
**R** = ReliaTel™ Microprocessor

## Digit 10 — Heating

**Note:** *Applicable to Digit 1, T models only.*

**0** = No Electric Heat  
**B** = 6 kW (3 phase)  
**C** = 9 kW (3 phase)  
**E** = 12 kW (3 phase)  
**G** = 18 kW (3 phase)  
**J** = 23 kW (3 phase)  
**K** = 27 kW (3 phase)  
**N** = 36 kW (3 phase)  
**P** = 54 kW (3 phase)

## Digit 10 — Heating (continued)

**Note:** *Applicable to Digit 1, Y models only.*

**L** = Low Heat  
**M** = Medium Heat  
**H** = High Heat  
**X** = Low Heat, Stainless Steel Heat Exchanger  
**Y** = Medium Heat, Stainless Steel Heat Exchanger  
**Z** = High Heat, Stainless Steel Heat Exchanger

## Digit 11 — Minor Design Sequence

**A** = First Sequence<sup>3</sup>  
**B** = Second Sequence<sup>4</sup>

## Digit 12, 13 — Service Sequence

**\*\*** = Factory Assigned

## Digit 14 — Fresh Air Selection

**0** = No Fresh Air  
**A** = Manual Outside Air Damper 0–50%<sup>5</sup>  
**B** = Motorized Outside Air Damper 0–50%<sup>6</sup>  
**C** = Economizer, Dry Bulb 0–100% without Barometric Relief<sup>7</sup>  
**D** = Economizer, Dry Bulb 0–100% with Barometric Relief<sup>7</sup>  
**E** = Economizer, Reference Enthalpy 0–100% without Barometric Relief<sup>7,8</sup>  
**F** = Economizer, Reference Enthalpy 0–100% with Barometric Relief<sup>7,8</sup>  
**G** = Economizer, Comparative Enthalpy 0–100% without Barometric Relief<sup>7,8</sup>  
**H** = Economizer, Comparative Enthalpy 0–100% with Barometric Relief<sup>7,8</sup>  
**K** = Low Leak Economizer with Barometric Relief  
**M** = Low Leak Economizer with Barometric Relief  
**P** = Low Leak Economizer with Comparative Enthalpy with Barometric Relief

## Digit 15 — Supply Fan/Drive Type/Motor

**0** = Standard Drive<sup>9</sup>  
**1** = Oversized Motor  
**2** = Optional Belt Drive Motor<sup>10</sup>  
**6** = Single Zone VAV<sup>11,12</sup>  
**7** = Multi-Speed Indoor Fan<sup>13</sup>  
**E** = VAV Supply Air Temperature Controls Standard Motor<sup>12</sup>

## Digit 16 — Hinged Service Access/ Filters

**0** = Standard Panels/Standard Filters  
**A** = Hinged Access Panels/Standard Filters  
**B** = Standard Panels/2" MERV 8 Filters  
**C** = Hinged Access Panels/2" MERV 8 Filters  
**D** = Standard Panels/2" MERV 13 Filters  
**E** = Hinged Access Panels/2" MERV 8 Filters

## Digit 17 — Condenser Coil Protection

**0** = Standard Coil  
**1** = Standard Coil with Hail Guard  
**2** = Black Epoxy Coil Pre-Coated Condenser Coil<sup>14</sup>  
**3** = Black Epoxy Coil Pre-Coated Condenser Coil with Hail Guard<sup>14</sup>  
**4** = CompleteCoat™ with Condenser Coil  
**5** = CompleteCoat™ with Hail Guard

## Digit 18 — Through-the-Base Provisions

**Note:** *Applicable to Digit 1, T or Y models only.*

**0** = No Through-the-Base Provisions  
**A** = Through-the-Base Electric<sup>15</sup>

**Note:** *Applicable to Digit 1, Y models only.*

**B** = Through-the-Base Gas Piping<sup>16</sup>  
**C** = Through-the-Base Electric and Gas Piping<sup>16</sup>

## Digit 19 — Disconnect/Circuit Breaker (three-phase only)

**0** = No Disconnect/No Circuit Breaker  
**1** = Unit Mounted/Non-Fused Disconnect<sup>15</sup>  
**2** = Unit Mounted Circuit Breaker<sup>15</sup>

## Digit 20— Convenience Outlet

**0** = No Convenience Outlet  
**A** = Unpowered Convenience Outlet  
**B** = Powered Convenience Outlet (three-phase only)<sup>17</sup>

## Digit 21— Communications Options<sup>8</sup>

**0** = No Communications Interface  
**1** = Trane® Communications Interface  
**2** = LonTalk® Communications Interface  
**3** = Novar 2024 Controls<sup>18</sup>  
**4** = Novar 3051 Controls without Zone Sensor<sup>18</sup>  
**5** = Novar 3051 Controls Interface with DCV<sup>18</sup>  
**6** = BACnet® Communications Interface  
**7** = Trane® Air-Fi® Communications Interface<sup>19</sup>

## Digit 22— Refrigeration System Option

**0** = Standard Refrigeration System<sup>20</sup>  
**B** = Dehumidification Option<sup>21,22</sup>

## Digit 23— Refrigeration Controls

**Note:** *Applicable to Digit 7 = E, F, G, H.*

**0** = No Refrigeration Control<sup>23</sup>  
**1** = Froststat™<sup>24,25</sup>

**Digit 24— Smoke Detector<sup>26</sup>**

- 0** = No Smoke Detector
- A** = Return Air Smoke Detector<sup>27,28</sup>
- B** = Supply Air Smoke Detector
- C** = Supply and Return Air Smoke Detectors<sup>27,28</sup>
- D** = Plenum Smoke Detector

**Digit 25— System Monitoring Controls**

- 0** = No Monitoring Control<sup>29</sup>
- 1** = Clogged Filter Switch<sup>29</sup>
- 2** = Fan Filter Switch<sup>29</sup>
- 3** = Discharge Air Sensing Tube<sup>29</sup>
- 4** = Clogged Filter Switch and Fan Filter Switch<sup>29</sup>
- 5** = Clogged Filter Switch and Discharge Air Sensing Tube<sup>29</sup>
- 6** = Fan Failure Switch and Discharge Air Sensing Tube<sup>29</sup>
- 7** = Clogged Filter Switch, Fan Failure Switch and Discharge Air Sensing Tube<sup>29</sup>
- 8** = NoVar Return Air Sensor (NOVAR 2024)<sup>30,18</sup>
- 9** = NoVar Zone Temp Sensor (NOVAR 3051)<sup>31,18</sup>
- A** = Condensate Drain Pan Overflow Switch
- B** = Clogged Filter Switch<sup>29</sup> and Condensate Drain Pan Overflow Switch
- C** = Fan Failure Switch<sup>29</sup> and Condensate Drain Pan Switch
- D** = Discharge Air Sensing<sup>29</sup> and Condensate Overflow Switch
- E** = Clogged Filter Switch<sup>29</sup>, Fan Failure Switch and Condensate Drain Pan Overflow Switch
- F** = Clogged Filter Switch<sup>29</sup>, Discharge Air Sensing Tube<sup>29</sup> and Condensate Drain Pan Overflow Switch
- G** = Fan Failure Switch, Discharge Air Sensing Tube<sup>29</sup> and Condensate Drain Pan Overflow Switch
- H** = Clogged Filter Switch<sup>29</sup>, Fan Failure Switch<sup>29</sup>, Discharge Air Sensing<sup>29</sup> and Condensate Drain Pan Overflow Switch

**Digit 26— System Monitoring Controls**

- 0** = No Monitoring Control
- A** = Demand Control Ventilation (CO<sub>2</sub>)<sup>32,33</sup>
- B** = Low Leak Economizer with FDD (Fault Detection & Diagnostics)
- C** = FDD (Fault Detection & Diagnostics) with DCV (Demand Control Ventilation)

**Digit 27— Unit Hardware Enhancements**

- 0** = No Enhancements
- 1** = Stainless Steel Drain Pan

**Digit 31— Advanced Unit Controls**

- 0** = Standard Unit Controls
- 1** = Human Interface



# Model Number Description

## Model Number Notes

### Notes:

1. Standard on T/YSC 6, 7.5 (single and dual systems), 8.5, 10 ton standard efficiency models and T/YHC 4, 5, 6, 7.5, 8.5, 10 ton MCH high efficiency models (except for 4, 5, 6 ton dehumidification models).
2. Available on 3 to 5 ton models.
3. Available for all models except gas/electric, 3 to 5 tons high efficiency single phase and 3 to 5 tons standard efficiency 3 phase.
4. Available for gas/electric, 3 to 5 tons high efficiency single phase and 3 to 5 tons standard efficiency single phase models.
5. Manual outside air damper will ship factory supplied within the unit, but must be field installed.
6. Motorized outside air damper is not available on multi-speed or SZVAV (single zone variable air volume) products.
7. Economizer with barometric relief is for downflow configured units only. Order economizer without barometric relief for horizontal configuration. Barometric relief for horizontal configured units must be ordered as field installed accessory.
8. Not available with electromechanical controls.
9. Multi-speed, direct drive motor with no belt drive option is standard on 3 to 5 ton, standard efficiency, 13/14 SEER units. Multi-speed, direct drive motor with a belt drive option is available for 3 to 5 ton, 15 SEER units. On 6 to 10 tons, multispeed direct drive is standard on all 10 ton and 6 (074) to 8.5 ton high efficiency. Belt drive is standard on all other units. Reference [Table 3, p. 28](#) table.
10. Reference [Table 3, p. 28](#) table.
11. Single zone VAV is only available on 6 to 10 tons high efficiency and 7.5 to 10 ton standard efficiency products with ReliaTel™ controls.
12. Discharge air sensing is also standard equipment on units with single zone and supply air temperature control VAV.
13. Multi-speed indoor fan available only on 6, 7.5 & 8.5 tons high efficiency, and 7.5 to 10 ton products with ReliaTel™ controls.
14. Epoxy coil and epoxy with hail guard options are not available for units with microchannel condenser coil.
15. Through-the-base electric required when ordering disconnect/circuit breaker options.
16. Includes gas piping and shutoff (field assembly required).
17. Requires use of disconnect or circuit breaker. Reference [Table 4, p. 29](#) table.
18. Novar is not available with SZVAV products.
19. Must be used with BACnet® open protocol.
20. Standard metering devices are TXVs.
21. Requires selection of 2" pleated filters (option B or C) for Digit 16.
22. Not available on all single phase or standard efficiency.
23. High pressure control is standard on all units.
24. Froststat™ cannot be field installed in electro-mechanical units.
25. Froststat™ standard on Y/TSC036 to 060G and T/YSC090H electromechanical, multi-speed and SZVAV (single zone variable air volume) products.
26. Not available with high temperature duct sensor accessory.
27. The return air smoke detector may not fit up or work properly on the Precedent™ units when used in conjunction with 3rd party accessories such as bolt on heat wheels, economizers and power exhaust. Do not order the return air smoke detectors when using this type of accessory.
28. Return air smoke detector cannot be ordered with Novar controls.
29. These options are standard when ordering Novar controls.
30. This option is used when ordering Novar controls.
31. Novar sensor utilized with Digit 21 = (4) Novar 3051 controls without zone sensor.
32. Demand control ventilation not available with electromechanical controls.
33. Demand control ventilation option includes wiring only. The CO<sub>2</sub> sensor is a field-installed only option.

**Table 3. Digit 15 Selection Details**

<b>Digit 15 = 0</b>
<b>Standard Efficiency</b>
3 Phase (3 to 5 Ton) = Multispeed Direct Drive Motor
3 Phase (6 to 8.5 Ton) = Belt Drive
3 Phase (10 Ton) = Ultra High Efficiency Direct Drive Plenum Fan
<b>High Efficiency</b>
3 Phase (3 to 5 ton) = High Efficiency Multispeed Direct Drive Motor
3 Phase (3 to 5 ton w/Dehumidification) = Belt Drive Motor
3 Phase [6 (074) to 10 ton] = Ultra High Efficiency Direct Drive Plenum Fan
<b>Digit 15 = 2</b>
<b>Standard Efficiency</b>
3 Phase = Not Available
<b>High Efficiency</b>
3 Phase (3 to 5 tons) = May be Ordered

**Table 3. Digit 15 Selection Details (continued)**

3 Phase (3 to 5 tons w/dehumidification) = Not Available
3 Phase (6 to 10 tons) = Not Available

**Table 4. Not Available in Model Number**

<b>Standard Efficiency</b>
3 to 5 Tons and 10 Ton w/575V
<b>High Efficiency</b>
3 to 5 Tons w/Standard Indoor Motor w/460V
High Efficiency 575V



# General Data

**Table 5. General data — 3 to 5 tons — standard efficiency**

	<b>3 Tons</b>	<b>4 Tons</b>	<b>5 Tons</b>
	<b>T/YSC036G3,4,W</b>	<b>T/YSC048G3,4,W</b>	<b>T/YSC060G3,4,W</b>
<b>Cooling Performance<sup>(a)</sup></b>			
Gross Cooling Capacity	37,000	49,000	60,000
EER/SEER <sup>(b)</sup>	12.0/14.0	12.0/14.0	12.0/14.0
Nominal cfm/AHRI Rated cfm	1,200/1,200	1,600/1,600	2,000/2,000
AHRI Net Cooling Capacity	36,000	48,000	58,500
System Power (kW)	3.00	4.00	4.88
<b>Compressor</b>			
Number/Type	1/Scroll	1/Scroll	1/Scroll
<b>Sound</b>			
Outdoor Sound Rating (dB) <sup>(c)</sup>	79	80	81
<b>Outdoor Coil</b>			
Type	Microchannel	Microchannel	Microchannel
Configuration	Full Face	Full Face	Full Face
Tube Size (in.)	0.63	0.63	1.00
Face Area (sq. ft.)	10.50	10.50	11.90
Rows/FPI (Fins per inch)	1/23	1/23	1/23
<b>Indoor Coil</b>			
Type	Microchannel	Microchannel	Microchannel
Configuration	Full Face	Full Face	Full Face
Tube Size (in.)	0.63	0.63	0.81
Face Area (sq. ft.)	6.98	6.98	8.15
Rows/FPI (Fins per inch)	2/16	2/16	2/16
Refrigerant Control	Thermal Expansion Valve	Thermal Expansion Valve	Thermal Expansion Valve
Drain Connection No./Size (in.)	1¾ NPT	1¾ NPT	1¾ NPT
<b>Outdoor Fan</b>			
Type	Propeller	Propeller	Propeller
No. Used/Diameter (in.)	1/22	1/22	1/22
Drive Type/No. Speeds	Direct/1	Direct/1	Direct/1
CFM	3,600	4,050	3950
Motor HP	0.25	0.33	0.40
Motor RPM	1,100	1,100	1100
<b>Indoor Fan</b>			
Type (Standard)	FC Centrifugal	FC Centrifugal	FC Centrifugal
No. Used/Diameter (in.)/Width (in.)	1	1	1
Drive Type/No. Speeds/RPM	11x11	11x11	11x11
Number Motors	Direct/5 <sup>(d)</sup>	Direct/5 <sup>(d)</sup>	Direct/5 <sup>(d)</sup>
Motor HP	0.75/1.5	1.0/1.5	1.0/1.5
Motor Frame Size	48	48	48
<b>Filters<sup>(e)</sup></b>			
Type Furnished	Throwaway	Throwaway	Throwaway
Number Size Recommended	(2) 20x35x2	(2) 20x35x2	(2) 20x35x2
<b>Refrigerant Charge<sup>(f)</sup></b>			
lbs of R-410A	3.2	3.5	4.8
<b>Heating Performance (Gas/ Electric Only)<sup>(g)</sup></b>			
<b>Heating Input</b>			
Low Heat Input (Btu)	80,000 / 56,000	80,000 / 56,000	80,000 / 56,000
Mid Heat Input (Btu)	100,000 / 70,000	100,000 / 70,000	100,000 / 70,000
High Heat Input (Btu)	120,000 / 84,000	130,000 / 91,000	150,000 / 105,000

**Table 5. General data – 3 to 5 tons – standard efficiency (continued)**

	<b>3 Tons</b>	<b>4 Tons</b>	<b>5 Tons</b>
	<b>T/YSC036G3,4,W</b>	<b>T/YSC048G3,4,W</b>	<b>T/YSC060G3,4,W</b>
<b>Heating Output</b>			
Low Heat Output (Btu)	64,800 / 45,300	64,800 / 45,300	64,800 / 45,300
Mid Heat Output (Btu)	81,000 / 56,700	81,000 / 56,700	81,000 / 56,700
High Heat Output (Btu)	97,200 / 68,000	105,300 / 73,700	121,500 / 85,100
<b>Steady State Efficiency %</b>			
Low Heat Input (Btu)	81	81	81
Mid Heat Input (Btu)	81	81	81
High Heat Input (Btu)	81	81	81
<b>No. Burners</b>			
Low Heat Output (Btu)	2	2	2
Mid Heat Output (Btu)	3	3	3
High Heat Output (Btu)	4	4	4
<b>No. Stages</b>			
Low Heat Input (Btu)	2	2	2
Mid Heat Input (Btu)	2	2	2
High Heat Input (Btu)	2	2	2
<b>Gas Supply Line Pressure</b>			
Natural (minimum/maximum)	4.5/14.0	4.5/14.0	4.5/14.0
LP (minimum/maximum)	11.0/14.0	11.0/14.0	11.0/14.0
<b>Gas Connection Pipe Size (in.)</b>			
Low Heat	1/2	1/2	1/2
Mid Heat	1/2	1/2	1/2
High Heat	3/4	3/4	3/4

- (a) Cooling performance is rated at 95°F ambient, 80°F entering dry bulb, 67°F entering wet bulb. Gross capacity does not include the effect of fan motor heat. AHRI capacity is net and includes the effect of fan motor heat. Units are suitable for operation to ±20% of nominal cfm. Units are certified in accordance with the Unitary Air-Conditioner Equipment certification program, which is based on AHRI Standard 210/240.
- (b) EER and/or SEER are rated at AHRI conditions and in accordance with DOE test procedures.
- (c) Outdoor sound rating shown is tested in accordance with AHRI Standard 270. For additional information reference the outdoor sound power level data in the performance section.
- (d) For multispeed direct drive rpm TSC/YSC values, reference the direct drive, evaporator fan performance data.
- (e) Optional 2" MERV 8 and MERV 13 filters also available.
- (f) Refrigerant charge is an approximate value. For a more precise value, see unit nameplate and service instructions.
- (g) Heating performance limit settings and rating data were established and approved under laboratory test conditions using American National Standards Institute standards. Ratings shown are for elevations up to 2000 feet. For elevations above 2000 feet, ratings should be reduced at the rate of 4% for each 1000 feet above sea level. Applicable to gas/electric units only.



## General Data

**Table 6. General data – 6 to 10 tons – standard efficiency**

	<b>6 Tons</b>	<b>7.5 Tons Single Compressor T/YSC 090H3,4,W</b>	<b>7.5 Tons Dual Compressor T/YSC 092H3,4,W</b>	<b>8.5 Tons</b>	<b>10 Tons</b>
<b>Cooling Performance<sup>(a)</sup></b>					
Gross Cooling Capacity	75,000	92,500	94,800	107,200	116,000
EER <sup>(b)</sup>	11.2	11.2	11.2	11.2	11.2
Nominal cfm/AHRI Rated cfm	2,400/2,100	3,000/2,400	3,000/2,325	3,400/2,720	4,000/4,000
AHRI Net Cooling Capacity	71,000	87,000	90,000	102,000	113,000
IEER (T/Y) <sup>(c)</sup>	12.9 / 12.7	12.9 / 12.7	12.9/12.7 <sup>(d)</sup>	12.9 / 12.7 <sup>(e)</sup>	12.9/12.7
System Power (kW)	6.36	7.77	8.04	9.11	10.09
<b>Compressor</b>					
Number/Type	1/Scroll	1/Scroll	2/Scroll	2/Scroll	2/Scroll
<b>Sound</b>					
Outdoor Sound Rating (dB) <sup>(f)</sup>	89	89	91	88	88
<b>Outdoor Coil</b>					
Type	Microchannel	Microchannel	Microchannel	Microchannel	Microchannel
Configuration	Full Face	Full Face	Face-split	Face-Split	Face Split
Tube Size (in.)	0.71	1.00	0.71	1	1
Face Area (sq. ft.)	16.91	16.91	17.31	20.77	20.77
Rows/FPI (Fins per inch)	1/23	1/21	1/23	1/21	1/20
<b>Indoor Coil</b>					
Type	Lanced	Lanced	Lanced	Lanced	Lanced
Configuration	Full Face	Full Face	Face-split	Intertwined	Intertwined
Tube Size (in.)	0.3125	0.3125	0.3125	0.3125	0.3125
Face Area (sq. ft.)	9.89	9.89	12.36	12.36	12.36
Rows/FPI (Fins per inch)	3/16	4/16	3/16	4/16	4/16
Refrigerant Control	Thermal Expansion Valve	Thermal Expansion Valve	Thermal Expansion Valve	Thermal Expansion Valve	Thermal Expansion Valve
Drain Connection No./Size (in.)	1¾ NPT	1¾ NPT	1¾ NPT	1¾ NPT	1¾ NPT
<b>Outdoor Fan</b>					
Type	Propeller	Propeller	Propeller	Propeller	Propeller
No. Used/Diameter (in.)	1/26	1/26	1/26	1/26	1/26
Drive Type/No. Speeds	Direct/1	Direct/1	Direct/1	Direct/1	Direct/1
CFM	6,037	6400	6600	6680	6800
Motor HP	0.70	0.70	0.70	0.70	0.70
Motor RPM	1,100	1,100	1,100	1,100	1,100
<b>Indoor Fan</b>					
Type	FC Centrifugal	FC Centrifugal	FC Centrifugal <sup>(g)</sup>	FC Centrifugal <sup>(g)</sup>	BC Plenum
No. Used/Diameter (in.)/Width (in.)	1/12x12	1/12x12	1/15x15 <sup>(h)</sup>	1/15x15 <sup>(h)</sup>	1/23.0315x6.14
Drive Type/No. Speeds/RPM	Belt/Variable/1,750	Belt/Variable/1,750	Belt/Variable/1,750 <sup>(i)</sup>	Belt/Variable/1,750 <sup>(i)</sup>	Direct/Variable <sup>(f)</sup>
Motor HP (Standard/Oversized)	1.0/2.0	1.0/3.0	1.0/3.0 <sup>(j)</sup>	2.0/3.0 <sup>(j)</sup>	2.75/—
Motor Frame Size (Standard/Oversized)	56/56	56/56	56/56	56/56	—/—
<b>Filters<sup>(k)</sup></b>					
Type Furnished	Throwaway	Throwaway	Throwaway	Throwaway	Throwaway
Number Size Recommended	(4) 16x25x2	(4) 16x25x2	(4) 20x25x2	(4) 20x25x2	(4) 20x25x2
<b>Refrigerant Charge<sup>(l)</sup></b>					
lbs of R-410A	5.5	7.5	3.8/3.6	6.2/3.9	5.6/4.4
<b>Heating Performance (Gas/ Electric Only)<sup>(m)</sup></b>					
<b>Heating Input</b>					
Low Heat Input (Btu)	80,000	120,000	120,000	120,000	150,000/105,000
Mid Heat Input (Btu)	120,000	150,000/105,000	150,000/105,000	150,000/105,000	200,000/140,000
High Heat Input (Btu)	150,000/105,000	200,000/140,000	200,000/140,000	200,000/140,000	235,000/164,500



**Table 6. General data – 6 to 10 tons – standard efficiency (continued)**

	<b>6 Tons</b>	<b>7.5 Tons Single Compressor</b>	<b>7.5 Tons Dual Compressor</b>	<b>8.5 Tons</b>	<b>10 Tons</b>
	<b>T/YSC 072H3,4,W</b>	<b>T/YSC 090H3,4,W</b>	<b>T/YSC 092H3,4,W</b>	<b>T/YSC 102H3,4,W</b>	<b>T/YSC 120H3,4,W</b>
<b>Heating Output</b>					
Low Heat Output (Btu)	64,000	96,000	96,000 <sup>(n)</sup>	96,000 <sup>(n)</sup>	120,000/84,000
Mid Heat Output (Btu)	96,000	120,000/84,000	120,000/84,000 <sup>(n)</sup>	120,000/84,000 <sup>(n)</sup>	160,000/112,000
High Heat Output (Btu)	120,000/84,000	160,000/112,000	160,000/112,000 <sup>(n)</sup>	160,000/112,000 <sup>(n)</sup>	188,000/131,600
<b>Steady State Efficiency %</b>					
Low Heat Input (Btu)	80	80	80 <sup>(o)</sup>	80 <sup>(o)</sup>	80
Mid Heat Input (Btu)	80	80	80 <sup>(o)</sup>	80 <sup>(o)</sup>	80
High Heat Input (Btu)	80	80	80 <sup>(o)</sup>	80 <sup>(o)</sup>	80
<b>No. Burners</b>					
Low Heat Output (Btu)	2	3	3	3	3
Mid Heat Output (Btu)	3	3	3	3	4
High Heat Output (Btu)	3	4	4 <sup>(p)</sup>	4 <sup>(p)</sup>	5
<b>No. Stages</b>					
Low Heat Input (Btu)	1	1	1	1	2
Mid Heat Input (Btu)	1	2	2	2	2
High Heat Input (Btu)	2	2	2	2	2
<b>Gas Supply Line Pressure</b>					
Natural (minimum/maximum)	4.5/14.0	4.5/14.0	4.5/14.0	4.5/14.0	4.5/14.0
LP (minimum/maximum)	11.0/14.0	11.0/14.0	11.0/14.0	11.0/14.0	11.0/14.0
<b>Gas Connection Pipe Size (in.)</b>					
Low Heat	1/2	1/2	1/2	1/2	3/4
Mid Heat	1/2	3/4	3/4	3/4	3/4
High Heat	3/4	3/4	3/4	3/4	3/4

- (a) Cooling performance is rated at 95°F ambient, 80°F entering dry bulb, 67°F entering wet bulb. Gross capacity does not include the effect of fan motor heat. AHRI capacity is net and includes the effect of fan motor heat. Units are suitable for operation to ±20% of nominal cfm. Units are certified in accordance with the Unitary Air-Conditioner Equipment certification program, which is based on AHRI Standard 340/360.
- (b) EER is rated at AHRI conditions and in accordance with DOE test procedures.
- (c) Integrated Efficiency Ratio (IEER) is rated in accordance with AHRI Standard 340/360. The IEER rating requires that the unit efficiency be determined at 100%, 75%, 50% and 25% load (net capacity) at the specified in AHRI Standard.
- (d) 13.7 IEER for SZVAV option, 13.4 IEER for Title24 2 speed fan option.
- (e) 13.7 IEER for SZVAV option, 13.4 IEER for Title24 2 speed fan option
- (f) Outdoor sound rating shown is tested in accordance with AHRI Standard 270. For additional information reference the outdoor sound power level data in the performance section.
- (g) For SZVAV / Title 24 Option, Backward Airfoil Plenum
- (h) For SZVAV / Title 24 Option, 1/23.03
- (i) For SZVAV / Title 24 Option, Plenum/Variable/1,700
- (j) For SZVAV / Title 24 Option, 2.75
- (k) Optional 2" MERV 8 and MERV 13 filters also available.
- (l) Refrigerant charge is an approximate value. For a more precise value, see unit nameplate and service instructions.
- (m) Heating performance limit settings and rating data were established and approved under laboratory test conditions using American National Standards Institute standards. Ratings shown are for elevations up to 2000 feet. For elevations above 2000 feet, ratings should be reduced at the rate of 4% for each 1000 feet above sea level. Applicable to gas/electric units only.
- (n) For SZVAV / Title24 Option, Low = 97,200, Mid = 121,500, High = 162,000
- (o) For SZVAV / Title24 Option, Steady State Efficiency = 81%
- (p) 5 burners for SZVAV / Title24 Option



## General Data

**Table 7. General data – 3 to 5 tons – high efficiency**

	<b>3 Tons T/YHC 036E3,4,W</b>	<b>4 Tons T/YHC 048E3,4,W</b>	<b>4 Tons T/YHC 048F3,4,W</b>	<b>5 Tons T/YHC 060E3,4,W</b>	<b>5 Tons T/YHC 060F3,4,W</b>
<b>Cooling Performance<sup>(a)</sup></b>					
Gross Cooling Capacity	37,600	49,930	49,930	61,000	61,000
EER/SEER <sup>(b)</sup>	E3,4= 12.7/15.0 EW=12.0/14.4"	14.2	13.2/15.0	14.2	12.85/15.0
Nominal cfm/AHRI Rated cfm	1,200/1,200	1,600/1,600	1,600/1,600	2,000/2,000	2,000/2,000
AHRI Net Cooling Capacity	37,000	49,000	49,000	60,000	60,000
System Power (kW)	2.99	3.67	3.67	4.67	4.67
<b>Compressor</b>					
Number/Type	1/Scroll	1/Scroll	1/Scroll	1/Scroll	1/Scroll
<b>Sound</b>					
Outdoor Sound Rating (dB) <sup>(c)</sup>	81	87	87	87	87
<b>Outdoor Coil</b>					
Type	Lanced	Lanced	Microchannel	Lanced	Microchannel
Configuration	Full Face	Full Face	Full Face	Full Face	Full Face
Tube Size (in.)	0.3125	0.3125	0.71	0.3125	0.71
Face Area (sq. ft.)	10.96	17.00	16.91	17	16.91
Rows/FPI (Fins per inch)	2/16	3/16	1/23	3/16	1/23
<b>Indoor Coil</b>					
Type	Lanced	Lanced	Lanced	Lanced	Lanced
Configuration	Full Face	Full Face	Full Face	Full Face	Full Face
Tube Size (in.)	0.3125	0.3125	0.3125	0.3125	0.3125
Face Area (sq. ft.)	7.71	9.27	9.27	9.89	9.89
Rows/FPI (Fins per inch)	3/16	3/16	3/16	4/16	4/16
Refrigerant Control	Thermal Expansion Valve	Thermal Expansion Valve	Thermal Expansion Valve	Thermal Expansion Valve	Thermal Expansion Valve
Drain Connection No./Size (in.)	1¾ NPT	1¾ NPT	1¾ NPT	1¾ NPT	1¾ NPT
<b>Outdoor Fan</b>					
Type	Propeller	Propeller	Propeller	Propeller	Propeller
No. Used/Diameter (in.)	1/22	1/26	1/26	1/26	1/26
Drive Type/No. Speeds	Direct/1	Direct/1	Direct/1	Direct/1	Direct/1
CFM	3,064	3,982	3,982	3,953	3,953
Motor HP	0.20	0.40	0.40	0.40	0.40
Motor RPM	1,075	1,075	1,075	1,075	1,075
<b>Indoor Fan</b>					
Type (Standard) <sup>(d)</sup>	FC Centrifugal	FC Centrifugal	FC Centrifugal	FC Centrifugal	FC Centrifugal
No. Used/Diameter (in.)/Width (in.)	1/11x11	1/11x11	1/11x11	1/11x11	1/11x11
Drive Type/No. Speeds/RPM <sup>(e)</sup>	Direct/5	Direct/5	Direct/5	Direct/5	Direct/5
Number Motors	1	1	1	□	□
Motor HP	0.75	1.0	1.0	1.0	1.0
Motor Frame Size	48	48	48	48	48
<b>Indoor Fan</b>					
Type (Optional)	FC Centrifugal	FC Centrifugal	FC Centrifugal	FC Centrifugal	FC Centrifugal
No. Used/Diameter (in.)/Width (in.)	1/11x11	1/11x11	1/11x11	1/11x11	1/11x11
Drive Type/No. Speeds/RPM	Belt/Variable	Belt/Variable	Belt/Variable	Belt/Variable	Belt/Variable
Number Motors	1	1	1	□	□
Motor HP	1.0	1.0	1.0	1.0	1.0
Motor Frame Size	56	56	56	56	56
<b>Filters<sup>(f)</sup></b>					
Type Furnished	Throwaway	Throwaway	Throwaway	Throwaway	Throwaway
Number Size Recommended	(2) 20x30x2	(4) 16x25x2	(4) 16x25x2	(4) 16x25x2	(4) 16x25x2
<b>Optional Hot Gas Reheat Coil</b>					
Tube Size (in.) OD	0.3125	0.3125	—	0.3125	—

**Table 7. General data – 3 to 5 tons – high efficiency (continued)**

	<b>3 Tons T/YHC 036E3,4,W</b>	<b>4 Tons T/YHC 048E3,4,W</b>	<b>4 Tons T/YHC 048F3,4,W</b>	<b>5 Tons T/YHC 060E3,4,W</b>	<b>5 Tons T/YHC 060F3,4,W</b>
Face Area (sq. ft.)	5.23	6.28	—	6.28	—
Rows/FPI (Fins per inch)	1/16	1/16	—	1/16	—
<b>Refrigerant Charge (lbs. of R-410A)<sup>(g)</sup></b>					
Standard	6.2	—	5.2	—	6.1
Optional Hot Gas Reheat Coil	10.5	15.2	—	15.7	—
<b>Heating Performance (Gas/Electric Only)<sup>(h)</sup></b>					
<b>Heating Input</b>					
Low Heat Input (Btu)	60,000	60,000	60,000	60,000	60,000
Mid Heat Input (Btu)	80,000	80,000	80,000	80,000	80,000
High Heat Input (Btu)	120,000	120,000	120,000	130,000	130,000
<b>Heating Output</b>					
Low Heat Output (Btu)	48,000	49,000	49,000	49,000	49,000
Mid Heat Output (Btu)	64,000	64,000	64,000	64,000	64,000
High Heat Output (Btu)	96,000	96,000	96,000	104,000	104,000
<b>AFUE %</b>					
Low Heat Input (Btu)	78	80	80	80	80
Mid Heat Input (Btu)	78	79	79	79	79
High Heat Input (Btu)	78	79	79	80	80
<b>Steady State Efficiency %</b>					
Low Heat Input (Btu)	80	81	81	81	81
Mid Heat Input (Btu)	80	80	80	80	80
High Heat Input (Btu)	80	81	81	80	80
<b>No. Burners</b>					
Low Heat Output (Btu)	2	2	2	2	2
Mid Heat Output (Btu)	2	2	2	2	2
High Heat Output (Btu)	3	3	3	3	3
<b>No. Stages</b>					
Low Heat Input (Btu)	1	1	1	1	1
Mid Heat Input (Btu)	1	1	1	1	1
High Heat Input (Btu)	1	1	1	1	1
<b>Gas Supply Line Pressure</b>					
Natural (minimum/maximum)	4.5/14.0	4.5/14.0	4.5/14.0	4.5/14.0	4.5/14.0
LP (minimum/maximum)	11.0/14.0	11.0/14.0	11.0/14.0	11.0/14.0	11.0/14.0
<b>Gas Connection Pipe Size (in.)</b>					
Low Heat	1/2	1/2	1/2	1/2	1/2
Mid Heat	1/2	1/2	1/2	1/2	1/2
High Heat	1/2	1/2	1/2	1/2	1/2

**Note:** 575V (W voltage) is only available as YHC. No THC models available with 575V (W voltage).

- (a) Cooling performance is rated at 95°F ambient, 80°F entering dry bulb, 67°F entering wet bulb. Gross capacity does not include the effect of fan motor heat. AHRI capacity is net and includes the effect of fan motor heat. Units are suitable for operation to ±20% of nominal cfm. Units are certified in accordance with the Unitary Air-Conditioner Equipment certification program, which is based on AHRI Standard 210/240.
- (b) EER and/or SEER are rated at AHRI conditions and in accordance with DOE test procedures.
- (c) Outdoor sound rating shown is tested in accordance with AHRI Standard 270. For additional information reference the outdoor sound power level data in the performance section.
- (d) Belt drive fan is standard on units with reheat option.
- (e) For multispeed direct drive rpm THC/YHC values, reference the direct drive, evaporator fan performance data.
- (f) Optional 2" MERV 8 and MERV 13 filters also available.
- (g) Refrigerant charge is an approximate value. For a more precise value, see unit nameplate and service instructions.



## General Data

**Table 8. General data – 6 to 7.5 tons – high efficiency**

	<b>6 Tons Single Compressor T/YHC072E/F3,4,W</b>	<b>6 Tons Dual Compressor T/YHC074F3,4</b>	<b>7.5 Tons T/YHC092F3,4,W</b>
<b>Cooling Performance<sup>(a)</sup></b>			
Gross Cooling Capacity	72,000	73,000	92,000
EER <sup>(b)</sup>	12.6	13.1	12.6
Nominal cfm/AHRI Rated cfm	2,400/2,100	2,400/2,100	3,000/2,625
AHRI Net Cooling Capacity	68,000	71,000	89,000
IEER <sup>(c)</sup>	14.5	15.5 <sup>(d)</sup>	14.5 <sup>(e)</sup>
System Power (kW)	5.37	5.42	7.06
<b>Compressor</b>			
Number/Type	1/Scroll	2/Scroll	2/Scroll
<b>Sound</b>			
Outdoor Sound Rating (dB) <sup>(f)</sup>	89	89	88
<b>Outdoor Coil</b>			
Type	Microchannel	Microchannel	Microchannel
Configuration	Full Face	Face-Split	Face-Split
Tube Size (in.)	0.71	1	1
Face Area (sq. ft.)	20.77	20.77	20.77
Rows/FPI (Fins per inch)	1/23	1/20	1/20
<b>Indoor Coil</b>			
Type	Lanced	Lanced	Lanced
Configuration	Full Face	Intertwined	Intertwined
Tube Size (in.)	0.3125	0.3125	0.3125
Face Area (sq. ft.)	12.36	12.36	12.36
Rows/FPI (Fins per inch)	4/16	4/16	4/16
Refrigerant Control	Thermal Expansion Valve	Thermal Expansion Valve	Thermal Expansion Valve
Drain Connection No./Size (in.)	1¾ NPT	1¾ NPT	1¾ NPT
<b>Outdoor Fan</b>			
Type	Propeller	Propeller	Propeller
No. Used/Diameter (in.)	1/26	1/26	1/26
Drive Type/No. Speeds	Direct/1	Direct/1	Direct/1
CFM	5900	5750	6800
Motor HP	0.7	0.7	0.75
Motor RPM	1100	1100	1100
<b>Indoor Fan</b>			
Type	FC Centrifugal	BC Plenum	BC Plenum
No. Used/Diameter (in.)/Width (in.)	1/15x15	1/23.0315x6.14	1/23.0315x6.14
Drive Type/No. Speeds <sup>(g)</sup> /RPM	Belt/Variable/1,750	Direct/Variable	Direct/Variable
Motor HP (Standard/Oversized)	1.0/2.0	2.75/—	2.75/—
Motor Frame Size (Standard/Oversized)	56/56	—/—	—/—
<b>Filters<sup>(h)</sup></b>			
Type Furnished	Throwaway	Throwaway	Throwaway
Number Size Recommended	(4) 20x25x2	(4) 20x25x2	(4) 20x25x2
<b>Optional Hot Gas Reheat Coil</b>			
Tube Size (in.) OD	—	—	0.3125
Face Area (sq. ft.)	—	—	8.652
Rows/FPI (Fins per inch)	—	—	1/16
<b>Refrigerant Charge<sup>(i)</sup></b>			
Standard	7.7	5.8/4.1	5.5/4.2
Optional Hot Gas Reheat Coil	—	—	6.2/4.3
<b>Heating Performance (Gas/ Electric Only)<sup>(j)</sup></b>			
<b>Heating Input</b>			

**Table 8. General data – 6 to 7.5 tons – high efficiency (continued)**

	<b>6 Tons</b>	<b>6 Tons</b>	<b>7.5 Tons</b>
	<b>Single Compressor T/YHC072E/F3,4,W</b>	<b>Dual Compressor T/YHC074F3,4</b>	<b>T/YHC092F3,4,W</b>
Low Heat Input (Btu)	80,000	80,000	120,000
Mid Heat Input (Btu)	120,000	120,000	150,000/105,000
High Heat Input (Btu)	150,000/105,000	150,000/105,000	200,000/140,000
<b>Heating Output</b>			
Low Heat Output (Btu)	64,000	64,800	96,000
Mid Heat Output (Btu)	96,000	97,200	120,000/84,000
High Heat Output (Btu)	120,000/84,000	121,500/85,050	160,000/112,000
<b>Steady State Efficiency %</b>			
Low Heat Input (Btu)	80	81	80
Mid Heat Input (Btu)	80	81	80
High Heat Input (Btu)	80	81	80
<b>No. Burners</b>			
Low Heat Output (Btu)	3	3	3
Mid Heat Output (Btu)	3	3	3
High Heat Output (Btu)	4	4	4
<b>No. Stages</b>			
Low Heat Input (Btu)	1	1	1
Mid Heat Input (Btu)	1	1	2
High Heat Input (Btu)	2	2	2
<b>Gas Supply Line Pressure</b>			
Natural (minimum/maximum)	4.5/14.0	4.5/14.0	4.5/14.0
LP (minimum/maximum)	11.0/14.0	11.0/14.0	11.0/14.0
<b>Gas Connection Pipe Size (in.)</b>			
Low Heat	1/2	1/2	1/2
Mid Heat	1/2	1/2	3/4
High Heat	3/4	3/4	3/4

**Note:** 575V (W voltage) is only available as YHC. No THC models available with 575V (W voltage).

- (a) Cooling performance is rated at 95°F ambient, 80°F entering dry bulb, 67°F entering wet bulb. Gross capacity does not include the effect of fan motor heat. AHRI capacity is net and includes the effect of fan motor heat. Units are suitable for operation to ±20% of nominal cfm. Units are certified in accordance with the Unitary Air-Conditioner Equipment certification program, which is based on AHRI Standard 340/360.
- (b) EER is rated at AHRI conditions and in accordance with DOE test procedures.
- (c) Integrated Efficiency Ratio (IEER) is rated in accordance with AHRI Standard 340/360. The IEER rating requires that the unit efficiency be determined at 100%, 75%, 50% and 25% load (net capacity) at the specified in AHRI Standard.
- (d) 16.0 IEER for multi-speed, SZVAV, and MZVAV.
- (e) 15.0 IEER for multi-speed, SZVAV, and MZVAV 208-230/460V.
- (f) Outdoor sound rating shown is tested in accordance with AHRI Standard 270. For additional information reference the outdoor sound power level data in the performance section.
- (g) For multispeed direct drive rpm T/YHC values, reference the direct drive, evaporator fan performance data. This note only applicable to T/YHC074F3,4,W and T/YHC092F3,4,W.
- (h) Optional 2" MERV 8 and MERV 13 filters also available.
- (i) Refrigerant charge is an approximate value. For a more precise value, see unit nameplate and service instructions.
- (j) Heating performance limit settings and rating data were established and approved under laboratory test conditions using American National Standards Institute standards. Ratings shown are for elevations up to 2000 feet. For elevations above 2000 feet, ratings should be reduced at the rate of 4% for each 1000 feet above sea level. Applicable to gas/electric units only.



## General Data

**Table 9. General data – 8.5 to 10 tons – high efficiency**

	<b>8.5 Tons</b>	<b>10 Tons</b>
	<b>T/YHC102F3,4,W</b>	<b>T/YHC120F3,4,W</b>
<b>Cooling Performance<sup>(a)</sup></b>		
Gross Cooling Capacity	104,000	116,000
EER <sup>(b)</sup>	I = 12.5 Y = 12.4	12.4
Nominal cfm/AHRI Rated cfm	3,400/2,720	4,000/3,800
AHRI Net Cooling Capacity	99,000	113,000
IEER <sup>(c)</sup>	T = 14.7 <sup>(d)</sup> YHC102FW = 14.5	IEER = 14.7 SZVAV, IEER = 15.2
System Power (kW)	7.92	9.11
<b>Compressor</b>		
Number/Type	2/Scroll	2/Scroll
<b>Sound</b>		
Outdoor Sound Rating (dB) <sup>(e)</sup>	89	87
<b>Outdoor Coil</b>		
Type	Microchannel	Microchannel
Configuration	Face Split	Face Split
Tube Size (in.)	1	1
Face Area (sq. ft.)	20.77	26.77
Rows/FPI (Fins per inch)	1/20	1/23
<b>Indoor Coil</b>		
Type	Lanced	Lanced
Configuration	Intertwined	Intertwined
Tube Size (in.)	0.3125	0.3125
Face Area (sq. ft.)	12.36	16.65
Rows/FPI (Fins per inch)	5/16	4/16
Refrigerant Control	Thermal Expansion Valve	Thermal Expansion Valve
Drain Connection No./Size (in.)	1¾ NPT	1¾ NPT
<b>Outdoor Fan</b>		
Type	Propeller	Propeller
No. Used/Diameter (in.)	1/26	1/30
Drive Type/No. Speeds	Direct/1	Direct/1
CFM	6,800	7,540
Motor HP	0.75	0.75
Motor RPM	1,100	1,100
<b>Indoor Fan</b>		
Type (Standard)	BC Plenum	BC Plenum
No. Used/Diameter (in.)/Width (in.)	1/23.0315x6.14	1/23.0315x6.14
Drive Type/No. Speeds/RPM <sup>(f)</sup>	Direct/Variable	Direct/Variable
Motor HP	2.75/—	2.75/—
Motor Frame Size	—/—	—/—
<b>Filters<sup>(g)</sup></b>		
Type Furnished	Throwaway	Throwaway
Number Size Recommended	(4) 20x25x2	(3) 20x25x2 (2) 20x30x2
<b>Optional Hot Gas Reheat Coil</b>		
Tube Size (in.) OD	0.3125	0.3125
Face Area (sq. ft.)	8.652	15.23
Rows/FPI (Fins per inch)	1/16	1/16
<b>Refrigerant Charge (lbs. of R-410A)<sup>(h)</sup></b>		
Standard	6.3/4.9	7.7/5.2
Optional Hot Gas Reheat Coil	6.6/4.7	8.6/5.2
<b>Heating Performance (Gas/Electric Only)<sup>(i)</sup></b>		

**Table 9. General data – 8.5 to 10 tons – high efficiency (continued)**

	<b>8.5 Tons</b>	<b>10 Tons</b>
	<b>T/YHC102F3,4,W</b>	<b>T/YHC120F3,4,W</b>
<b>Heating Input</b>		
Low Heat Input (Btu)	120,000	150,000/105,000
Mid Heat Input (Btu)	150,000/105,000	200,000/140,000
High Heat Input (Btu)	200,000/140,000	250,000/175,000
<b>Heating Output</b>		
Low Heat Output (Btu)	96,000	120,000/84,000
Mid Heat Output (Btu)	120,000/84,000	160,000/112,000
High Heat Output (Btu)	160,000/112,000	200,000/140,000
<b>Steady State Efficiency %</b>		
Low Heat Input (Btu)	80	80
Mid Heat Input (Btu)	80	80
High Heat Input (Btu)	80	80
<b>No. Burners</b>		
Low Heat Output (Btu)	3	3
Mid Heat Output (Btu)	3	4
High Heat Output (Btu)	4	5
<b>No. Stages</b>		
Low Heat Input (Btu)	1	2
Mid Heat Input (Btu)	2	2
High Heat Input (Btu)	2	2
<b>Gas Supply Line Pressure</b>		
Natural (minimum/maximum)	4.5/14.0	4.5/14.0
LP (minimum/maximum)	11.0/14.0	11.0/14.0
<b>Gas Connection Pipe Size (in.)</b>		
Low Heat	1/2	3/4
Mid Heat	3/4	3/4
High Heat	3/4	3/4

**Note:** 575V (W voltage) is only available as YHC. No THC models available with 575V (W voltage).

- (a) Cooling performance is rated at 95°F ambient, 80°F entering dry bulb, 67°F entering wet bulb. Gross capacity does not include the effect of fan motor heat. AHRI capacity is net and includes the effect of fan motor heat. Units are suitable for operation to ±20% of nominal cfm. Units are certified in accordance with the Unitary Air-Conditioner Equipment certification program, which is based on AHRI Standard 340/360.
- (b) EER is rated at AHRI conditions and in accordance with DOE test procedures.
- (c) Integrated Efficiency Ratio (IEER) is rated in accordance with AHRI Standard 340/360. The IEER rating requires that the unit efficiency be determined at 100%, 75%, 50% and 25% load (net capacity) at the specified in AHRI Standard.
- (d) 15.5 IEER for SZVAV
- (e) Outdoor sound rating shown is tested in accordance with AHRI Standard 270. For additional information reference the outdoor sound power level data in the performance section.
- (f) For multispeed direct drive rpm THC/YHC values, reference the direct drive, evaporator fan performance data.
- (g) Optional 2" MERV 8 and MERV 13 filters also available.
- (h) Refrigerant charge is an approximate value. For a more precise value, see unit nameplate and service instructions.
- (i) Heating performance limit settings and rating data were established and approved under laboratory test conditions using American National Standards Institute standards. Ratings shown are for elevations up to 2000 feet. For elevations above 2000 feet, ratings should be reduced at the rate of 4% for each 1000 feet above sea level. Applicable to gas/electric units only.



# Gross Cooling Capacities

Table 10. Gross cooling capacities 3 tons standard efficiency — three phase T/YSC036G3,4,W

CFM	Ent DB (°F)	Ambient Temperature (°F)			Ambient Temperature (°F)			Ambient Temperature (°F)											
		85			95			105											
		Entering Wet Bulb Temp (°F)			Entering Wet Bulb Temp (°F)			Entering Wet Bulb Temp (°F)											
		61	67	73	61	67	73	61	67	73									
		MBh	SHC	MBh	SHC	MBh	SHC	MBh	SHC	MBh	SHC								
960	75	33	28	37	21	42	15	31	27	35	20	41	14	30	26	33	20	38	13
	80	33	33	37	27	43	20	32	32	36	26	41	20	30	30	34	25	38	19
	85	34	34	38	33	42	26	33	33	36	32	40	25	32	32	34	31	38	24
	90	37	37	38	38	42	31	35	35	36	36	40	31	34	34	34	34	38	30
1080	75	34	30	38	22	43	15	32	29	36	22	41	14	30	28	34	21	39	14
	80	34	34	38	29	43	21	32	32	36	28	41	21	31	30	34	27	39	20
	85	36	36	38	35	43	27	35	35	37	34	41	27	33	33	35	34	39	26
	90	38	38	39	39	43	34	37	37	37	37	41	33	35	35	35	35	39	32
1200	75	34	32	39	24	44	15	33	31	37	23	42	15	31	30	35	22	40	14
	80	35	35	39	31	44	22	33	33	37	30	42	21	31	31	35	29	40	21
	85	37	37	39	38	44	29	36	36	37	37	42	28	34	34	35	35	40	28
	90	40	40	39	39	44	36	38	38	38	38	42	35	36	36	36	36	40	34
1320	75	35	34	39	25	45	16	33	33	37	24	43	15	31	31	35	23	40	14
	80	35	35	40	32	44	23	34	34	38	32	43	23	32	32	36	31	40	22
	85	38	38	40	40	45	31	37	37	38	38	42	30	35	35	36	36	40	29
	90	41	41	40	40	45	38	39	39	6	38	43	38	38	38	37	37	40	37
1440	75	35	35	40	26	45	16	34	33	38	25	43	15	32	32	36	24	41	14
	80	36	36	40	34	45	24	35	35	38	33	43	23	34	34	36	33	40	22
	85	39	39	40	40	45	32	38	38	38	38	43	32	36	36	36	36	41	31
	90	42	42	41	41	45	41	40	40	39	39	43	40	39	39	38	38	41	39

CFM	Ent DB (°F)	Ambient Temperature (°F)			Ambient Temperature (°F)								
		115			125								
		Entering Wet Bulb Temp (°F)			Entering Wet Bulb Temp (°F)								
		61	67	73	61	67	73						
		MBh	SHC	MBh	SHC	MBh	SHC						
960	75	28	26	32	19	36	12	26	25	30	18	34	12
	80	28	28	32	25	36	18	26	26	30	24	34	17
	85	30	30	32	30	36	23	29	29	30	29	34	23
	90	32	32	32	32	36	29	31	31	30	30	34	28
1080	75	28	28	32	20	37	13	27	26	30	19	35	12
	80	29	29	32	26	36	19	28	28	30	26	34	18
	85	32	32	33	33	37	25	30	30	31	31	34	24
	90	34	34	33	33	37	31	32	32	31	31	35	30
1200	75	29	29	33	21	37	13	27	27	31	20	35	12
	80	30	30	33	28	37	20	29	29	31	27	34	19
	85	33	33	33	33	37	27	31	31	31	31	35	26
	90	35	35	34	34	38	34	33	33	33	33	35	33
1320	75	29	29	33	22	38	13	27	27	31	21	35	12
	80	31	31	33	30	37	21	30	30	31	29	35	20
	85	33	33	34	34	38	28	32	32	32	31	35	27
	90	36	36	36	36	38	36	34	34	34	34	36	35
1440	75	30	30	34	23	38	14	28	28	31	23	36	13
	80	32	32	34	32	38	22	30	30	32	31	35	21
	85	34	34	34	34	38	30	32	32	32	32	36	29
	90	37	37	37	37	41	41	35	35	35	35	36	36

Notes:

1. All capacities shown are gross and have not considered indoor fan heat. To obtain NET cooling capacity subtract indoor fan heat. For indoor fan heat formula, refer to appropriate airflow table notes.
2. MBh = Total gross capacity
3. SHC = Sensible heat capacity



**Table 11. Gross cooling capacities 4 tons standard efficiency – three phase T/YSC048G3,4,W**

CFM	Ent DB (°F)	Ambient Temperature (°F)			Ambient Temperature (°F)			Ambient Temperature (°F)											
		85			95			105											
		Entering Wet Bulb Temp (°F)			Entering Wet Bulb Temp (°F)			Entering Wet Bulb Temp (°F)											
		61	67	73	61	67	73	61	67	73									
		MBh	SHC	MBh	SHC	MBh	SHC	MBh	SHC	MBh	SHC								
1280	75	46	38	50	28	55	19	42	35	47	27	53	18	39	34	45	26	49	17
	80	44	44	50	35	56	26	42	42	47	34	53	25	40	40	45	33	49	24
	85	47	47	50	42	56	33	45	45	48	41	53	32	43	43	45	40	50	31
	90	50	50	50	49	56	40	48	48	48	48	53	39	45	45	45	45	50	38
1440	75	45	39	51	29	56	19	43	38	48	28	53	18	40	37	45	27	50	17
	80	45	45	51	37	56	27	43	43	48	36	53	26	42	42	45	35	50	25
	85	49	49	51	45	56	35	47	47	48	44	53	34	45	45	46	43	50	33
	90	52	52	51	51	57	43	50	50	49	49	54	42	47	47	47	47	50	41
1600	75	46	42	51	31	57	20	43	40	49	30	54	19	41	39	46	28	50	17
	80	46	46	52	40	57	28	45	45	49	39	54	27	43	43	46	37	51	26
	85	50	50	52	49	57	37	48	48	49	47	54	36	46	46	46	46	51	35
	90	53	53	53	53	57	46	51	51	51	51	54	45	48	48	48	48	51	44
1760	75	46	44	52	32	58	20	44	43	49	31	54	19	41	41	46	30	51	18
	80	49	49	52	42	58	30	47	47	50	41	55	28	44	44	47	40	51	27
	85	52	52	53	52	58	39	50	50	50	50	55	38	47	47	47	47	51	37
	90	55	55	55	55	58	49	52	52	52	52	55	48	50	50	50	50	51	46
1920	75	47	47	53	33	58	20	44	44	50	32	55	19	42	42	47	31	51	18
	80	50	50	53	44	58	31	48	48	50	43	55	30	45	45	47	42	52	29
	85	53	53	53	53	58	41	51	51	50	50	55	40	48	48	47	47	51	39
	90	56	56	56	56	59	52	53	53	53	53	55	51	50	50	50	50	52	49
	Ent DB (°F)	Ambient Temperature (°F)			Ambient Temperature (°F)														
		115			125														
		Entering Wet Bulb Temp (°F)			Entering Wet Bulb Temp (°F)														
		61	67	73	61	67	73												
CFM		MBh	SHC	MBh	SHC	MBh	SHC	MBh	SHC	MBh	SHC								
1280	75	37	33	42	24	46	15	34	32	38	23	42	14						
	80	37	37	42	32	46	22	36	36	39	30	42	21						
	85	41	41	42	39	46	30	38	38	39	37	42	28						
	90	43	43	42	42	46	37	40	40	40	40	42	35						
1440	75	38	36	42	26	46	16	35	34	39	24	42	14						
	80	40	40	42	34	46	24	37	37	39	32	42	22						
	85	42	42	43	42	47	32	39	39	39	39	42	30						
	90	44	44	44	44	47	39	41	41	41	41	42	38						
1600	75	38	38	43	27	47	16	35	35	39	26	42	14						
	80	41	41	43	36	47	25	38	38	39	35	42	23						
	85	43	43	43	43	47	33	40	40	40	40	42	32						
	90	45	45	45	45	47	42	42	42	42	42	43	41						
1760	75	39	38	43	28	47	16	36	36	39	27	42	15						
	80	42	42	43	38	47	26	39	39	40	37	42	24						
	85	44	44	44	44	47	35	41	41	41	41	43	34						
	90	46	46	46	46	47	45	42	42	42	42	43	42						
1920	75	39	39	43	30	47	16	37	37	40	28	42	15						
	80	42	42	44	40	47	27	39	39	40	39	42	25						
	85	45	45	45	45	47	37	41	41	41	41	43	36						
	90	47	47	47	47	47	47	43	43	43	43	43	43						

**Notes:**

1. All capacities shown are gross and have not considered indoor fan heat. To obtain NET cooling capacity subtract indoor fan heat. For indoor fan heat formula, refer to appropriate airflow table notes.
2. MBh = Total gross capacity
3. SHC = Sensible heat capacity



# Gross Cooling Capacities

**Table 12. Gross cooling capacities 5 tons standard efficiency – three phase T/YSC060G3,4,W**

CFM	Ent DB (°F)	Ambient Temperature (°F)			Ambient Temperature (°F)			Ambient Temperature (°F)											
		85			95			105											
		Entering Wet Bulb Temp (°F)			Entering Wet Bulb Temp (°F)			Entering Wet Bulb Temp (°F)											
		61	67	73	61	67	73	61	67	73									
		MBh	SHC	MBh	SHC	MBh	SHC	MBh	SHC	MBh	SHC								
1600	75	54	46	60	35	68	24	51	45	57	34	64	23	48	44	54	33	61	21
	80	54	54	60	44	68	33	51	51	58	43	65	32	49	49	55	42	61	30
	85	56	56	61	54	67	42	54	54	58	52	64	41	52	52	55	51	61	39
	90	59	59	61	61	68	51	57	57	58	58	65	50	55	55	55	55	61	49
1800	75	55	50	61	37	69	24	52	49	59	36	66	23	50	47	55	34	62	22
	80	55	55	62	48	69	35	53	53	59	46	66	33	50	50	56	45	61	32
	85	58	58	62	58	69	45	56	56	59	57	66	44	53	53	56	55	62	42
	90	61	61	62	62	69	55	59	59	60	59	66	54	57	57	57	57	62	53
2000	75	56	53	63	39	70	25	53	52	60	38	67	24	50	50	56	36	63	22
	80	57	56	63	51	70	36	54	54	60	49	67	35	52	52	57	48	62	33
	85	60	60	63	62	70	48	58	58	60	60	67	46	55	55	57	57	63	45
	90	64	64	64	64	70	59	61	61	61	61	67	58	58	58	58	63	56	
2200	75	57	57	64	41	71	25	54	54	61	40	68	24	51	51	57	38	63	23
	80	58	58	64	54	71	38	56	56	61	52	67	36	53	53	57	51	63	35
	85	62	62	64	64	71	50	59	59	61	61	68	49	57	57	58	58	63	48
	90	65	65	65	65	71	63	63	63	63	63	68	62	60	60	60	60	64	60
2400	75	58	58	65	43	72	26	55	55	61	41	68	24	52	52	58	40	64	23
	80	59	59	65	57	72	39	57	57	62	55	68	38	54	54	58	54	64	37
	85	63	63	65	65	72	53	61	61	62	62	68	52	58	58	59	58	64	50
	90	67	67	67	67	72	67	64	64	64	64	69	65	61	61	61	61	64	64

CFM	Ent DB (°F)	Ambient Temperature (°F)			Ambient Temperature (°F)								
		115			125								
		Entering Wet Bulb Temp (°F)			Entering Wet Bulb Temp (°F)								
		61	67	73	61	67	73						
		MBh	SHC	MBh	SHC	MBh	SHC						
1600	75	45	43	51	31	57	20	42	41	47	29	51	18
	80	46	46	51	40	57	29	43	43	47	39	51	27
	85	49	49	51	50	56	38	46	46	47	47	51	36
	90	52	52	52	52	57	47	48	48	48	48	52	45
1800	75	46	46	52	33	57	20	43	42	47	31	52	18
	80	47	47	51	46	57	30	44	44	48	42	52	29
	85	51	51	52	52	57	41	47	47	48	48	52	39
	90	54	54	53	53	58	51	50	50	50	50	52	49
2000	75	47	47	52	35	58	21	43	43	48	33	52	19
	80	49	49	53	46	58	32	45	45	48	45	52	30
	85	52	52	53	53	61	46	48	48	49	48	53	42
	90	55	55	55	55	58	55	51	51	51	51	53	53
2200	75	48	48	53	37	59	21	44	44	48	35	53	19
	80	50	50	53	49	58	33	46	46	49	48	53	32
	85	53	53	54	54	59	46	49	49	49	49	53	44
	90	56	56	56	56	59	59	52	52	52	52	53	53
2400	75	48	48	54	39	59	21	44	44	49	37	53	19
	80	51	51	54	52	59	35	47	47	49	49	53	33
	85	54	54	54	54	59	49	50	50	50	50	53	47
	90	57	57	57	57	59	59	53	53	53	53	53	53

**Notes:**

1. All capacities shown are gross and have not considered indoor fan heat. To obtain NET cooling capacity subtract indoor fan heat. For indoor fan heat formula, refer to appropriate airflow table notes.
2. MBh = Total gross capacity
3. SHC = Sensible heat capacity

Table 13. Gross cooling capacities 6 tons standard efficiency – three phase T/YSC072H3,4,W

CFM	Ent DB (°F)	Ambient Temperature (°F)						Ambient Temperature (°F)											
		85						95						105					
		Entering Wet Bulb Temp (°F)						Entering Wet Bulb Temp (°F)						Entering Wet Bulb Temp (°F)					
		61		67		73		61		67		73		61		67		73	
MBh	SHC	MBh	SHC	MBh	SHC	MBh	SHC	MBh	SHC	MBh	SHC	MBh	SHC	MBh	SHC	MBh	SHC		
1920	75	69.0	55.1	75.2	40.7	83.7	19.8	65.0	52.5	70.8	38.6	79.0	18.1	60.7	49.8	66.2	36.3	74.0	16.3
	80	70.7	64.2	75.8	53.2	83.1	35.7	66.8	61.4	71.5	50.9	78.5	33.8	62.6	58.5	66.9	48.3	73.6	31.7
	85	73.0	71.4	76.9	63.8	83.1	49.8	69.2	68.4	72.7	61.3	78.5	47.6	65.1	65.1	68.2	58.5	73.7	45.3
	90	75.9	75.9	78.6	72.6	83.6	62.0	72.1	72.1	74.5	69.8	79.1	59.6	68.1	68.1	70.1	66.8	74.3	57.0
2160	75	71.0	57.3	77.0	42.5	85.3	21.2	66.9	54.7	72.5	40.3	80.4	19.4	62.5	51.8	67.8	37.9	75.3	17.5
	80	73.0	66.6	77.8	55.2	84.9	37.4	68.9	63.8	73.4	52.8	80.1	35.4	64.6	60.7	68.7	50.2	75.1	33.2
	85	75.5	74.1	79.1	66.1	85.0	51.7	71.5	71.0	74.8	63.4	80.3	49.4	67.3	67.3	70.2	60.5	75.4	46.9
	90	78.5	78.5	81.0	75.1	85.7	64.1	74.6	74.6	76.7	72.2	81.1	61.6	70.5	70.5	72.2	69.1	76.3	58.9
2400	75	72.8	59.3	78.5	44.1	86.5	22.5	68.6	56.6	73.9	41.8	81.6	20.6	64.1	53.6	69.1	39.3	76.4	18.5
	80	74.9	68.9	79.5	57.1	86.3	38.8	70.8	65.9	75.0	54.5	81.5	36.7	66.4	62.7	70.2	51.8	76.4	34.4
	85	77.6	76.6	81.0	68.2	86.7	53.4	73.6	73.4	76.6	65.4	81.9	51.0	69.2	69.2	71.9	62.4	76.9	48.4
	90	80.9	80.9	83.1	77.5	87.6	66.0	76.9	76.9	78.8	74.4	82.9	63.4	72.7	72.7	74.2	71.2	77.9	60.6
2640	75	74.3	61.2	79.8	45.6	87.6	23.5	70.0	58.3	75.1	43.2	82.5	21.5	65.4	55.3	70.2	40.6	77.2	19.3
	80	76.7	71.0	81.0	58.8	87.6	40.1	72.4	67.9	76.4	56.1	82.6	37.9	67.9	64.6	71.5	53.3	77.4	35.5
	85	79.6	78.9	82.7	70.1	88.1	54.9	75.4	75.4	78.2	67.2	83.2	52.4	71.0	71.0	73.4	64.1	78.1	49.7
	90	83.0	83.0	85.0	79.6	89.2	67.7	78.9	78.9	80.5	76.5	84.4	65.0	74.6	74.6	75.8	73.1	79.4	62.1
2880	75	75.6	62.9	80.8	46.9	88.4	24.4	71.1	59.9	76.0	44.4	83.2	22.3	66.5	56.8	71.0	41.6	77.8	20.0
	80	78.1	72.9	82.2	60.3	88.6	41.3	73.8	69.7	77.5	57.5	83.5	38.9	69.2	66.3	72.5	54.6	78.2	36.4
	85	81.2	81.1	84.1	71.9	89.3	56.2	76.9	76.9	79.5	68.9	84.3	53.6	72.4	72.4	74.6	65.7	79.1	50.9
	90	84.9	84.9	86.6	81.6	90.6	69.3	80.7	80.7	82.0	78.3	85.7	66.5	76.2	76.2	77.2	74.9	80.5	63.5
1920	Ent DB (°F)	Ambient Temperature (°F)						Ambient Temperature (°F)											
		115						125											
		Entering Wet Bulb Temp (°F)						Entering Wet Bulb Temp (°F)											
		61		67		73		61		67		73							
CFM	Ent DB (°F)	MBh	SHC	MBh	SHC	MBh	SHC	MBh	SHC	MBh	SHC	MBh	SHC	MBh	SHC	MBh	SHC	MBh	SHC
1920	75	56.2	46.9	61.3	33.8	68.8	14.3	51.4	43.8	56.2	31.2	63.3	12.0						
	80	58.2	55.3	62.2	45.6	68.4	29.4	53.5	52.0	57.1	42.7	63.0	27.0						
	85	60.7	60.7	63.5	55.5	68.6	42.8	56.1	56.1	58.6	52.4	63.3	40.1						
	90	64.8	64.8	65.4	63.6	69.4	54.2	60.0	60.0	60.6	60.2	64.1	51.3						
2160	75	57.9	48.8	62.8	35.3	70.0	15.3	53.0	45.6	57.6	32.5	64.4	13.0						
	80	60.1	57.4	63.8	47.3	69.9	30.8	55.3	54.0	58.7	44.3	64.4	28.2						
	85	62.8	62.8	65.4	57.5	70.2	44.3	58.1	58.1	60.3	54.2	64.8	41.5						
	90	66.8	66.8	67.5	65.8	71.2	56.0	61.9	61.9	62.5	62.3	65.9	52.9						
2400	75	59.4	50.5	64.0	36.6	71.0	16.2	54.4	47.2	58.7	33.7	65.3	13.8						
	80	61.7	59.4	65.2	48.9	71.0	31.9	56.9	55.8	60.0	45.7	65.4	29.2						
	85	64.7	64.7	67.0	59.2	71.6	45.7	59.9	59.9	61.8	55.9	66.1	42.7						
	90	68.6	68.6	69.3	67.7	72.8	57.6	63.6	63.6	64.2	64.1	67.3	54.4						
2640	75	60.6	52.1	65.0	37.7	71.7	17.0	55.5	48.6	59.6	34.8	65.9	14.4						
	80	63.2	61.1	66.4	50.2	71.9	32.9	58.2	57.5	61.1	47.0	66.2	30.1						
	85	66.3	66.3	68.4	60.8	72.7	46.9	61.4	61.4	63.1	57.4	67.1	43.8						
	90	70.2	70.2	70.9	69.6	74.1	59.0	65.7	65.7	65.7	65.7	68.5	55.7						
2880	75	61.5	53.4	65.7	38.7	72.2	17.5	56.3	49.9	60.2	35.6	66.3	14.9						
	80	64.3	62.7	67.3	51.4	72.6	33.6	59.2	59.0	61.9	48.1	66.8	30.7						
	85	67.6	67.6	69.5	62.3	73.6	47.9	62.6	62.6	64.1	58.7	67.9	44.7						
	90	71.5	71.5	72.2	71.2	75.1	60.3	66.9	66.9	66.9	66.9	69.5	56.9						

Notes:

1. All capacities shown are gross and have not considered indoor fan heat. To obtain NET cooling capacity subtract indoor fan heat. For indoor fan heat formula, refer to appropriate airflow table notes.
2. MBh = Total gross capacity
3. SHC = Sensible heat capacity



# Gross Cooling Capacities

**Table 14. Gross cooling capacities 7.5 tons standard efficiency – three phase T/YSC090H3,4,W**

CFM	Ent DB (°F)	Ambient Temperature (°F)			Ambient Temperature (°F)			Ambient Temperature (°F)											
		85			95			105											
		Entering Wet Bulb Temp (°F)			Entering Wet Bulb Temp (°F)			Entering Wet Bulb Temp (°F)											
		61	67	73	61	67	73	61	67	73									
		MBh	SHC	MBh	SHC	MBh	SHC	MBh	SHC	MBh	SHC								
2400	75	84.4	70.0	94.5	54.2	104.5	37.6	79.8	67.7	89.4	51.9	98.7	35.3	74.9	65.2	83.9	49.5	92.6	32.8
	80	84.7	83.1	94.7	67.4	104.6	50.9	80.2	80.2	89.5	65.1	98.9	48.6	75.4	75.4	84.1	62.7	92.8	46.2
	85	86.6	86.6	94.7	80.6	104.7	64.2	83.0	83.0	89.7	78.3	99.0	61.9	78.9	78.9	84.3	75.9	92.9	59.5
	90	95.0	93.8	95.0	93.8	104.8	77.5	87.7	87.7	90.1	90.1	99.1	75.2	83.5	83.5	84.8	84.8	93.1	72.8
2700	75	86.3	74.8	96.4	57.0	106.2	38.3	81.5	72.4	91.0	54.6	100.1	35.9	76.4	69.9	85.3	52.1	93.8	33.4
	80	86.8	86.8	96.5	71.9	106.3	53.3	82.1	82.1	91.2	69.5	100.3	50.9	77.3	77.3	85.5	67.0	93.9	48.4
	85	90.5	90.5	96.7	86.7	106.4	68.3	86.4	86.4	91.4	84.4	100.4	65.9	82.0	82.0	85.7	81.9	94.1	63.4
	90	95.6	95.6	97.2	97.2	106.6	83.2	91.3	91.3	92.2	92.2	100.6	80.8	86.7	86.7	86.9	86.9	94.2	78.3
3000	75	87.9	79.7	97.9	59.8	107.5	38.9	82.8	77.2	92.3	57.3	101.2	36.5	77.5	74.6	86.4	54.8	94.6	34.0
	80	88.7	88.7	98.1	76.3	107.6	55.6	84.0	84.0	92.5	73.9	101.4	53.2	79.3	79.3	86.6	71.3	94.8	50.7
	85	93.7	93.7	98.2	92.8	107.8	72.3	89.3	89.3	92.7	90.4	101.6	69.8	84.6	84.6	86.9	86.9	95.0	67.3
	90	98.9	98.9	99.3	99.3	107.9	88.8	94.3	94.3	94.2	94.2	101.7	86.4	89.3	89.3	89.4	89.4	95.1	83.9
3300	75	89.2	84.4	99.2	62.5	108.6	39.6	84.0	81.9	93.3	60.0	102.1	37.1	78.4	78.4	87.2	57.4	95.3	34.5
	80	90.7	90.7	99.4	80.7	108.7	57.9	86.1	86.1	93.6	78.2	102.3	55.5	81.7	81.7	87.5	75.6	95.5	52.9
	85	96.4	96.4	99.6	98.8	108.9	76.2	91.7	91.7	93.9	93.9	102.4	73.8	86.7	86.7	88.0	88.0	95.7	71.2
	90	101.7	101.7	101.4	101.4	109.1	94.4	96.8	96.8	96.9	96.9	102.6	92.0	91.5	91.5	91.6	91.6	95.8	89.4
3600	75	90.3	89.1	100.2	65.2	109.5	40.2	84.9	84.9	94.2	62.6	102.8	37.7	79.3	79.3	87.9	59.9	95.8	35.0
	80	92.8	92.8	100.5	85.1	109.6	60.2	88.5	88.5	94.5	82.5	103.0	57.7	83.4	83.4	88.2	79.8	96.0	55.1
	85	98.7	98.7	100.8	100.8	109.8	80.2	93.8	93.8	95.0	95.0	103.2	77.7	88.5	88.5	89.0	89.0	96.2	75.0
	90	104.0	104.0	104.1	104.1	110.0	100.1	98.8	98.8	98.9	98.9	103.4	97.5	93.3	93.3	93.3	93.3	96.4	94.9

CFM	Ent DB (°F)	Ambient Temperature (°F)			Ambient Temperature (°F)								
		115			125								
		Entering Wet Bulb Temp (°F)			Entering Wet Bulb Temp (°F)								
		61	67	73	61	67	73						
		MBh	SHC	MBh	SHC	MBh	SHC						
2400	75	69.7	62.7	78.1	46.9	86.1	30.3	64.0	59.9	71.7	44.2	78.8	27.5
	80	70.4	70.4	78.3	60.1	86.2	43.6	65.2	65.2	71.9	57.4	78.9	40.9
	85	74.5	74.5	78.5	73.3	86.3	57.0	69.6	69.6	72.1	70.6	79.0	54.2
	90	78.9	78.9	79.3	79.3	86.5	70.2	73.6	73.6	73.7	73.7	79.2	67.5
2700	75	70.9	67.3	79.2	49.5	86.9	30.8	64.9	64.5	72.5	46.7	79.3	28.0
	80	72.4	72.4	79.4	64.4	87.1	45.8	67.5	67.5	72.7	61.6	79.5	43.0
	85	77.2	77.2	79.7	79.3	87.2	60.8	71.9	71.9	73.2	73.2	79.6	58.0
	90	81.7	81.7	81.8	81.8	87.4	75.7	75.9	75.9	76.0	76.0	79.8	72.9
3000	75	71.8	71.8	80.0	52.1	87.5	31.3	65.7	65.7	73.1	49.2	79.7	28.4
	80	74.7	74.7	80.2	68.6	87.7	48.0	69.3	69.3	73.3	65.7	79.9	45.1
	85	79.4	79.4	80.8	80.8	87.9	64.6	73.7	73.7	74.1	74.1	80.0	61.7
	90	83.9	83.9	84.0	84.0	88.0	81.2	77.7	77.7	77.8	77.8	80.2	78.3
3300	75	72.6	72.6	80.7	54.6	88.0	31.8	66.5	66.5	73.5	51.7	79.9	28.9
	80	76.5	76.5	80.9	72.8	88.2	50.2	70.8	70.8	73.8	69.9	80.1	47.2
	85	81.3	81.3	81.7	81.7	88.3	68.4	75.2	75.2	75.0	75.0	80.3	65.5
	90	85.7	85.7	85.7	85.7	88.5	86.6	79.1	79.1	79.1	79.1	80.6	80.6
3600	75	73.4	73.4	81.2	57.1	88.3	32.3	67.2	67.2	73.8	54.1	80.1	29.3
	80	78.0	78.0	81.4	77.0	88.5	52.3	72.0	72.0	74.1	74.0	80.3	49.3
	85	82.8	82.8	82.6	82.6	88.7	72.2	76.3	76.3	76.4	76.4	80.4	69.3
	90	87.1	87.1	86.0	86.0	88.9	88.9	80.1	80.1	80.1	80.1	80.8	80.8

**Notes:**

1. All capacities shown are gross and have not considered indoor fan heat. To obtain NET cooling capacity subtract indoor fan heat. For indoor fan heat formula, refer to appropriate airflow table notes.
2. MBh = Total gross capacity
3. SHC = Sensible heat capacity

Table 15. Gross cooling capacities 7.5 tons standard efficiency – three phase T/YSC092H3,4,W

CFM	Ent DB (°F)	Ambient Temperature (°F)						Ambient Temperature (°F)			Ambient Temperature (°F)								
		85						95			105								
		Entering Wet Bulb Temp (°F)						Entering Wet Bulb Temp (°F)			Entering Wet Bulb Temp (°F)								
		61		67		73		61	67	73	61	67	73						
		MBh	SHC	MBh	SHC	MBh	SHC	MBh	SHC	MBh	SHC	MBh	SHC	MBh	SHC	MBh	SHC		
2325	75	87.8	69.8	97.0	54.1	105.0	37.3	83.0	67.2	91.6	51.6	99.2	34.9	77.8	64.5	86.0	48.9	92.9	32.2
	80	88.5	82.0	97.2	66.8	105.1	50.1	83.7	79.3	91.9	64.3	99.3	47.6	78.7	76.6	86.2	61.6	92.9	45.0
	85	90.8	90.8	97.4	79.5	105.2	62.8	86.7	86.7	92.2	76.9	99.3	60.3	82.2	82.2	86.6	74.1	93.0	57.6
	90	98.0	91.5	98.0	91.5	105.2	75.4	91.1	91.1	92.8	88.9	99.4	72.9	86.5	86.5	87.3	86.2	93.0	70.3
2700	75	90.3	75.5	99.1	57.5	106.6	38.0	85.2	72.6	93.5	54.9	100.5	35.5	79.8	69.7	87.5	52.1	93.9	32.8
	80	91.3	89.8	99.3	72.2	106.7	52.8	86.4	86.1	93.7	69.6	100.5	50.2	81.5	81.5	87.8	66.8	93.9	47.6
	85	95.5	95.5	99.7	86.3	106.8	67.6	90.9	90.9	94.2	83.5	100.6	65.0	86.0	86.0	88.3	80.7	93.9	62.3
	90	100.0	100.0	100.7	99.9	107.1	82.3	95.3	95.3	95.5	95.3	100.8	79.7	90.0	90.0	90.1	90.1	94.2	77.0
3000	75	91.9	79.8	100.3	60.1	107.6	38.6	86.6	77.0	94.5	57.4	101.3	36.0	81.1	74.0	88.4	54.6	94.5	33.3
	80	93.6	93.5	100.5	76.4	107.8	55.0	88.9	88.9	94.8	73.8	101.3	52.4	83.9	83.9	88.7	71.0	94.5	49.6
	85	98.4	98.4	101.1	91.8	108.1	71.5	93.6	93.6	95.4	89.0	101.6	68.8	88.3	88.3	89.4	86.1	94.7	66.0
	90	102.8	102.8	102.9	102.9	108.6	87.9	97.6	97.6	97.7	97.7	102.0	84.4	91.9	91.9	92.0	92.0	95.1	81.5
3300	75	93.2	84.2	101.3	62.6	108.5	39.2	87.8	81.3	95.4	60.0	101.9	36.5	82.2	78.3	89.1	57.1	95.0	33.8
	80	96.0	96.0	101.6	80.6	108.9	57.3	91.1	91.1	95.7	77.1	102.1	54.6	85.8	85.8	89.4	74.1	95.1	51.8
	85	100.8	100.8	102.3	97.3	109.2	75.4	95.6	95.6	96.5	94.5	102.5	72.7	90.0	90.0	90.3	90.1	95.3	69.9
	90	104.9	104.9	105.1	105.1	109.8	92.5	99.4	99.4	99.5	99.5	103.0	89.6	93.5	93.5	93.6	93.6	95.9	86.5
3600	75	94.4	88.5	102.1	65.2	109.3	39.8	88.9	85.6	96.0	62.5	102.5	37.1	83.1	82.4	89.6	59.6	95.4	34.3
	80	98.0	98.0	102.4	83.8	109.8	59.6	92.9	92.9	96.4	80.9	102.9	56.8	87.4	87.4	89.9	77.9	95.6	54.0
	85	102.7	102.7	103.3	102.4	110.1	79.3	97.3	97.3	97.4	97.4	103.2	76.6	91.3	91.3	91.3	91.3	95.9	73.7
	90	107.1	107.1	107.3	107.3	110.8	97.7	101.4	101.4	101.5	101.5	103.9	94.7	95.1	95.1	95.2	95.2	96.6	91.6
CFM	Ent DB (°F)	Ambient Temperature (°F)						Ambient Temperature (°F)											
		115						125											
		Entering Wet Bulb Temp (°F)						Entering Wet Bulb Temp (°F)											
		61		67		73		61	67	73									
		MBh	SHC	MBh	SHC	MBh	SHC	MBh	SHC	MBh	SHC	MBh	SHC	MBh	SHC	MBh	SHC		
2325	75	72.5	61.5	80.0	46.2	86.1	29.5	66.8	58.3	73.4	43.2	78.7	26.6						
	80	73.5	73.0	80.2	58.8	86.2	42.2	68.2	68.2	73.6	55.9	78.7	39.3						
	85	77.5	77.5	80.6	70.9	86.1	54.9	72.1	72.1	74.0	67.8	78.6	51.9						
	90	81.4	81.4	81.6	81.2	86.2	67.5	75.5	75.5	75.6	75.6	78.6	64.5						
2700	75	74.2	66.7	81.2	49.3	86.9	30.1	68.2	63.5	74.3	46.3	79.3	27.1						
	80	76.5	76.5	81.5	64.0	86.8	44.7	71.0	71.0	74.6	60.3	79.1	41.7						
	85	80.7	80.7	82.0	77.7	86.8	59.4	74.7	74.7	75.2	74.3	79.0	56.4						
	90	84.2	84.2	84.3	84.3	87.1	73.3	77.5	77.5	77.5	77.5	79.3	70.1						
3000	75	75.3	70.9	81.9	51.8	87.4	30.5	69.1	67.7	74.8	48.7	79.6	27.6						
	80	78.5	78.5	82.2	67.2	87.2	46.8	72.6	72.6	75.1	63.9	79.3	43.8						
	85	82.5	82.5	82.9	82.3	87.4	63.2	76.0	76.0	76.1	76.1	79.4	60.1						
	90	85.6	85.6	85.6	85.6	87.8	78.3	78.6	78.6	78.7	78.7	79.7	74.9						
3300	75	76.2	75.1	82.4	54.2	87.7	31.0	69.9	69.9	75.1	51.1	79.8	28.0						
	80	80.2	80.2	82.7	70.9	87.6	48.9	73.9	73.9	75.4	67.5	79.5	45.8						
	85	83.8	83.8	83.9	83.9	87.8	66.9	76.9	76.9	76.9	76.9	79.6	62.6						
	90	87.0	87.0	87.1	87.1	88.4	83.3	79.7	79.7	79.7	79.7	80.1	79.4						
3600	75	77.1	77.1	82.7	56.6	88.0	31.5	70.9	70.9	75.3	53.4	80.0	28.5						
	80	81.4	81.4	83.1	74.6	88.0	51.0	74.8	74.8	75.7	71.1	79.7	47.9						
	85	84.8	84.8	84.8	84.8	88.2	69.4	77.5	77.5	77.5	77.5	79.8	65.8						
	90	88.3	88.3	88.3	88.3	88.8	88.0	80.4	80.4	80.4	80.4	80.5	80.5						

Notes:

1. All capacities shown are gross and have not considered indoor fan heat. To obtain NET cooling capacity subtract indoor fan heat. For indoor fan heat formula, refer to appropriate airflow table notes.
2. MBh = Total gross capacity
3. SHC = Sensible heat capacity



# Gross Cooling Capacities

**Table 16. Gross cooling capacities 8.5 tons standard efficiency – three phase T/YSC102H3,4,W**

CFM	Ent DB (°F)	Ambient Temperature (°F)			Ambient Temperature (°F)			Ambient Temperature (°F)											
		85			95			105											
		Entering Wet Bulb Temp (°F)			Entering Wet Bulb Temp (°F)			Entering Wet Bulb Temp (°F)											
		61	67	73	61	67	73	61	67	73									
		MBh	SHC	MBh	SHC	MBh	SHC	MBh	SHC	MBh	SHC								
2720	75	100.2	81.2	111.0	62.8	120.8	43.3	94.1	78.0	104.3	59.7	113.5	40.2	87.7	74.7	97.1	56.4	105.5	37.0
	80	100.8	94.3	111.2	77.9	121.0	58.5	94.8	88.9	104.5	74.7	113.7	55.4	89.1	83.9	97.3	71.4	105.7	52.1
	85	104.0	101.7	111.5	92.8	121.2	73.6	98.6	97.5	104.9	89.7	113.9	70.5	93.1	93.1	97.7	86.0	105.9	67.2
	90	112.1	104.7	112.1	104.7	121.4	88.6	104.0	104.0	105.9	98.9	114.1	85.5	98.1	98.1	99.5	93.9	106.2	82.2
3060	75	102.3	86.6	112.8	65.8	122.4	44.0	95.9	83.3	105.8	62.6	114.8	40.8	89.1	79.3	98.2	59.1	106.4	37.4
	80	103.6	97.6	113.1	82.7	122.6	61.0	97.8	93.0	106.1	79.5	115.0	57.8	91.6	88.1	98.5	76.0	106.6	54.5
	85	108.0	108.0	113.5	99.1	122.9	78.0	102.4	102.4	106.6	95.8	115.2	74.8	96.4	96.4	99.1	91.4	106.8	71.4
	90	113.5	113.5	115.1	108.5	123.1	94.9	107.7	107.7	108.8	103.7	115.5	91.7	101.2	101.2	101.8	98.4	107.1	88.3
3400	75	104.0	91.4	114.2	68.7	123.7	44.6	97.4	87.9	106.9	65.4	115.7	41.3	90.3	83.4	99.0	61.9	107.0	37.9
	80	106.3	101.9	114.5	87.5	123.9	63.5	100.2	97.1	107.2	84.2	115.9	60.2	93.7	91.9	99.4	80.6	107.3	56.8
	85	111.5	111.5	115.1	105.7	124.2	82.4	105.5	105.5	108.0	100.2	116.2	79.1	98.9	98.9	100.3	93.6	107.5	75.6
	90	116.9	116.9	117.7	113.3	124.7	100.7	110.6	110.6	111.0	108.2	116.5	97.9	103.6	103.6	103.6	102.9	107.9	93.7
3740	75	105.5	96.5	115.3	71.6	124.7	45.2	98.6	91.5	107.7	68.2	116.4	41.8	91.4	85.3	99.6	64.6	107.5	38.3
	80	108.7	105.9	115.6	92.3	125.0	66.0	102.3	101.0	108.1	88.8	116.7	62.7	95.7	95.7	100.0	84.6	107.7	59.1
	85	114.3	114.3	116.5	108.8	125.3	86.7	107.9	107.9	109.2	102.5	117.0	83.4	100.9	100.9	101.8	96.2	108.0	79.8
	90	119.7	119.7	119.8	117.8	125.7	107.5	113.0	113.0	112.9	112.9	117.5	103.3	105.6	105.6	105.7	105.7	108.6	99.2
4080	75	106.7	99.6	116.1	74.5	125.6	45.8	99.7	93.6	108.3	71.0	117.0	42.4	92.6	87.0	100.0	67.3	107.8	38.8
	80	110.7	110.0	116.6	97.0	125.9	68.5	104.4	104.4	108.8	92.8	117.3	65.1	97.3	97.3	100.5	89.0	108.0	61.4
	85	116.7	116.7	117.8	111.1	126.2	91.2	109.9	109.9	110.8	105.1	117.6	87.7	102.5	102.5	102.9	99.3	108.4	84.0
	90	122.1	122.1	122.1	122.1	126.8	112.9	115.0	115.0	115.2	115.2	118.3	108.5	107.3	107.3	107.4	107.4	109.1	101.2

CFM	Ent DB (°F)	Ambient Temperature (°F)			Ambient Temperature (°F)								
		115			125								
		Entering Wet Bulb Temp (°F)			Entering Wet Bulb Temp (°F)								
		61	67	73	61	67	73						
		MBh	SHC	MBh	SHC	MBh	SHC						
2720	75	80.9	70.8	89.4	52.9	96.9	33.6	73.8	67.2	81.2	49.3	87.6	29.9
	80	82.9	79.1	89.7	67.9	97.1	48.7	76.3	74.0	81.5	64.3	87.7	45.0
	85	87.1	87.1	90.2	82.4	97.3	63.8	80.5	80.5	82.1	75.0	87.9	60.1
	90	91.7	91.7	92.4	88.5	97.5	78.8	84.4	84.4	84.6	82.7	88.1	75.1
3060	75	82.1	75.3	90.2	55.6	97.4	33.9	74.7	69.0	81.6	51.8	87.7	30.2
	80	85.1	82.9	90.5	72.5	97.6	50.9	78.0	77.9	82.0	68.2	87.8	47.2
	85	89.8	89.8	91.4	84.0	97.8	67.9	82.4	82.4	83.4	78.0	88.0	64.1
	90	94.1	94.1	94.2	92.8	98.1	84.2	86.1	86.1	86.2	86.2	88.4	80.1
3400	75	83.0	77.1	90.7	58.2	97.7	34.3	75.8	70.8	81.8	54.4	87.7	30.4
	80	86.8	86.8	91.1	76.4	97.9	53.1	79.7	79.7	82.3	72.5	87.8	49.3
	85	91.7	91.7	92.7	87.1	98.1	72.0	83.8	83.8	84.2	80.9	88.0	68.1
	90	95.9	95.9	96.0	96.0	98.6	89.7	87.4	87.4	87.5	87.5	88.6	80.6
3740	75	84.2	78.9	91.0	60.8	97.9	34.6	76.5	73.1	81.8	56.9	87.6	30.7
	80	88.6	88.6	91.5	80.7	98.1	55.4	80.7	80.7	82.4	75.5	87.7	51.4
	85	93.2	93.2	93.7	90.1	98.3	76.1	84.8	84.8	84.8	83.6	87.9	71.3
	90	97.5	97.5	97.5	97.5	99.0	91.5	88.2	88.2	88.3	88.3	88.9	82.9
4080	75	85.1	81.3	91.2	63.4	97.9	35.0	77.1	75.1	81.8	59.4	87.4	31.0
	80	89.8	89.8	91.8	84.2	98.1	57.6	81.5	81.5	82.5	76.6	87.4	53.6
	85	94.4	94.4	94.5	93.0	98.4	80.2	85.5	85.5	85.5	85.5	87.7	75.1
	90	98.6	98.6	98.7	98.7	99.6	92.7	88.7	88.7	88.7	88.7	89.0	85.2

**Notes:**

1. All capacities shown are gross and have not considered indoor fan heat. To obtain NET cooling capacity subtract indoor fan heat. For indoor fan heat formula, refer to appropriate airflow table notes.
2. MBh = Total gross capacity
3. SHC = Sensible heat capacity

**Table 17. Gross cooling capacities 10 tons standard efficiency — three phase T/YSC120H3,4,W**

CFM	Ent DB (°F)	Ambient Temperature (°F)			Ambient Temperature (°F)			Ambient Temperature (°F)											
		85			95			105											
		Entering Wet Bulb Temp (°F)			Entering Wet Bulb Temp (°F)			Entering Wet Bulb Temp (°F)											
		61	67	73	61	67	73	61	67	73									
		MBh	SHC	MBh	SHC	MBh	SHC	MBh	SHC	MBh	SHC								
3200	75	107.5	91.8	119.4	70.1	131.0	47.3	101.6	88.9	112.9	67.2	123.7	44.5	95.5	85.9	106.0	64.3	116.1	41.5
	80	108.7	107.6	119.6	88.0	131.1	65.3	103.2	103.2	113.0	85.1	123.8	62.5	97.5	97.5	106.2	82.1	116.2	59.6
	85	113.3	113.3	119.8	105.8	131.2	83.3	108.2	108.2	113.3	102.9	123.9	80.5	102.8	102.8	106.6	99.9	116.3	77.5
	90	121.2	120.6	121.2	120.6	131.3	101.2	114.0	114.0	115.1	115.1	124.1	98.3	108.4	108.4	108.8	108.8	116.4	95.4
3600	75	109.7	98.3	121.5	73.8	132.8	48.2	103.6	95.2	114.6	70.9	125.2	45.3	97.2	92.2	107.5	67.8	117.3	42.3
	80	111.8	111.8	121.6	93.9	132.9	68.5	106.1	106.1	114.8	91.0	125.3	65.6	100.3	100.3	107.7	88.0	117.4	62.6
	85	117.6	117.6	122.0	113.8	132.9	88.6	112.1	112.1	115.3	110.9	125.4	85.8	106.4	106.4	108.4	106.4	117.5	82.8
	90	123.8	123.8	124.4	124.4	133.1	108.8	118.1	118.1	118.1	118.1	125.6	105.9	112.0	112.0	112.1	112.1	117.7	102.9
4000	75	111.5	104.6	123.1	77.5	134.1	49.0	105.2	101.5	116.0	74.5	126.3	46.1	98.7	97.2	108.7	71.4	118.2	43.0
	80	114.6	114.6	123.3	99.8	134.2	71.5	109.2	109.2	116.3	96.8	126.4	68.6	103.3	103.3	109.0	93.7	118.3	65.6
	85	121.2	121.2	123.9	121.3	134.3	94.0	115.4	115.4	117.3	115.7	126.5	91.0	109.3	109.3	110.4	110.4	118.4	88.0
	90	127.5	127.5	127.3	127.3	134.5	116.3	121.3	121.3	121.5	121.5	126.8	113.4	114.8	114.8	114.9	114.9	118.7	110.2
4400	75	113.1	110.8	124.4	81.1	135.2	49.8	106.7	105.9	117.2	78.0	127.2	46.8	100.4	100.4	109.6	74.9	118.8	43.8
	80	117.7	117.7	124.7	105.6	135.3	74.6	111.8	111.8	117.5	102.6	127.3	71.6	105.7	105.7	110.0	99.3	119.0	68.6
	85	124.3	124.3	126.0	125.7	135.4	99.3	118.1	118.1	119.1	119.1	127.4	96.3	111.7	111.7	112.0	112.0	119.1	93.2
	90	130.5	130.5	130.6	130.6	135.7	123.7	124.0	124.0	124.1	124.1	127.7	120.7	117.0	117.0	117.1	117.1	119.4	115.9
4800	75	114.6	114.5	125.5	84.7	136.1	50.6	108.4	108.4	118.1	81.6	127.9	47.6	101.7	101.7	110.3	78.4	119.4	44.5
	80	120.2	120.2	125.8	111.5	136.2	77.7	114.1	114.1	118.5	108.2	128.0	74.7	107.7	107.7	110.8	105.0	119.5	71.5
	85	126.8	126.8	127.7	127.7	136.3	104.6	120.4	120.4	120.3	120.3	128.2	101.6	113.6	113.6	113.4	113.4	119.6	98.5
	90	133.0	133.0	133.1	133.1	136.7	131.1	126.1	126.1	126.2	126.2	128.6	125.7	118.8	118.8	118.9	118.9	120.2	119.2
CFM	Ent DB (°F)	Ambient Temperature (°F)			Ambient Temperature (°F)														
		115			125														
		Entering Wet Bulb Temp (°F)			Entering Wet Bulb Temp (°F)														
		61	67	73	61	67	73												
		MBh	SHC	MBh	SHC	MBh	SHC	MBh	SHC	MBh	SHC								
3200	75	89.2	82.8	98.9	61.2	107.9	38.5	82.5	79.6	91.2	58.0	99.0	35.2						
	80	91.6	91.6	99.1	79.1	108.0	56.5	85.8	85.8	91.4	75.9	99.1	53.2						
	85	97.1	97.1	99.6	96.6	108.1	74.5	90.8	90.8	92.3	91.0	99.2	71.2						
	90	102.3	102.3	102.5	102.5	108.3	92.4	95.5	95.5	95.6	95.6	99.4	88.9						
3600	75	90.7	88.6	100.1	64.7	108.8	39.2	84.1	83.4	92.1	61.4	99.6	35.8						
	80	94.7	94.7	100.3	84.9	108.9	59.5	88.4	88.4	92.3	81.6	99.7	56.1						
	85	100.2	100.2	101.5	101.3	109.1	79.7	93.4	93.4	93.8	93.8	99.8	76.3						
	90	105.4	105.4	105.5	105.5	109.3	99.6	97.9	97.9	97.9	97.9	100.0	95.7						
4000	75	92.3	92.3	101.0	68.2	109.5	39.9	85.4	85.4	92.7	64.8	100.0	36.5						
	80	97.2	97.2	101.3	90.4	109.6	62.4	90.4	90.4	93.1	87.0	100.1	59.0						
	85	102.7	102.7	103.1	103.1	109.7	84.8	95.3	95.3	95.2	95.2	100.2	81.4						
	90	107.7	107.7	107.8	107.8	110.0	105.9	99.5	99.5	99.6	99.6	100.6	99.0						
4400	75	93.7	93.7	101.7	71.7	109.9	40.6	86.6	86.6	93.2	68.2	100.3	37.1						
	80	99.2	99.2	102.1	96.0	110.1	65.3	92.0	92.0	93.7	91.3	100.4	61.9						
	85	104.7	104.7	104.7	104.7	110.2	90.0	96.8	96.8	96.9	96.9	100.5	86.6						
	90	109.4	109.4	109.5	109.5	110.7	109.3	100.7	100.7	100.8	100.8	101.0	101.0						
4800	75	94.9	94.9	102.3	75.1	110.3	41.2	87.8	87.8	93.6	71.6	100.4	37.8						
	80	100.9	100.9	102.8	100.5	110.4	68.3	93.3	93.3	94.4	94.0	100.5	64.8						
	85	106.2	106.2	106.3	106.3	110.5	95.2	98.0	98.0	98.0	98.0	100.6	91.4						
	90	110.7	110.7	110.8	110.8	111.2	111.2	101.5	101.5	101.5	101.5	101.4	101.4						

**Notes:**

1. All capacities shown are gross and have not considered indoor fan heat. To obtain NET cooling capacity subtract indoor fan heat. For indoor fan heat formula, refer to appropriate airflow table notes.
2. MBh = Total gross capacity
3. SHC = Sensible heat capacity



# Gross Cooling Capacities

**Table 18. Gross cooling capacities 3 tons high efficiency — three phase T/YHC036E3,4,W**

CFM	Ent DB (°F)	Ambient Temperature (°F)						Ambient Temperature (°F)						Ambient Temperature (°F)					
		85						95						105					
		Entering Wet Bulb Temp (°F)						Entering Wet Bulb Temp (°F)						Entering Wet Bulb Temp (°F)					
		61		67		73		61		67		73		61		67		73	
MBh	SHC	MBh	SHC	MBh	SHC	MBh	SHC	MBh	SHC	MBh	SHC	MBh	SHC	MBh	SHC	MBh	SHC		
600	75	30.5	23.1	34.4	16.9	39.8	7.7	28.2	21.7	32.0	15.8	37.1	6.9	25.9	20.3	29.4	14.6	34.3	5.9
	80	31.1	27.1	34.4	22.6	39.1	15.1	28.9	25.6	32.0	21.4	36.4	14.0	26.6	24.0	29.5	20.0	33.7	13.0
	85	32.2	30.3	34.8	27.5	38.8	21.5	30.0	28.7	32.4	26.0	36.2	20.4	27.7	26.9	29.9	24.6	33.4	19.1
	90	33.6	32.6	35.6	31.4	38.9	27.1	31.5	30.8	33.2	29.9	36.3	25.8	29.2	28.9	30.7	28.2	33.6	24.4
720	75	32.0	24.9	35.9	18.6	41.0	9.2	29.7	23.5	33.3	17.4	38.3	8.2	27.3	22.0	30.7	16.1	35.4	7.2
	80	32.8	29.1	36.0	24.4	40.5	16.7	30.6	27.5	33.5	23.1	37.8	15.6	28.2	25.9	30.9	21.7	35.0	14.4
	85	34.1	32.5	36.5	29.4	40.4	23.3	31.8	30.8	34.0	27.9	37.7	22.1	29.4	28.9	31.5	26.4	34.9	20.7
	90	35.6	35.0	37.4	33.6	40.6	29.1	33.4	33.1	35.0	31.9	37.9	27.7	31.1	31.1	32.5	30.2	35.2	26.2
840	75	33.5	26.6	37.1	20.1	42.2	10.5	31.1	25.1	34.5	18.8	39.3	9.4	28.6	23.5	31.8	17.4	36.4	8.3
	80	34.4	31.0	37.4	26.1	41.8	18.1	32.1	29.3	34.9	24.7	39.0	17.0	29.6	27.6	32.2	23.2	36.1	15.7
	85	35.8	34.5	38.1	31.3	41.8	25.0	33.5	32.7	35.6	29.7	39.0	23.6	31.0	30.8	32.9	28.0	36.2	22.2
	90	37.5	37.2	39.2	35.6	42.2	30.9	35.2	35.2	36.7	33.9	39.5	29.4	33.7	33.7	34.1	32.0	36.6	27.9
960	75	35.0	27.4	39.0	20.8	43.0	13.1	32.6	25.9	36.4	18.7	40.3	11.7	30.1	24.4	33.6	17.6	37.3	10.3
	80	35.6	33.5	39.4	26.2	43.5	19.2	33.3	32.2	36.8	24.7	40.7	17.8	30.8	30.6	34.0	23.1	37.8	16.2
	85	37.3	37.3	39.8	31.6	43.9	25.2	35.2	35.2	37.2	30.1	41.2	23.5	33.0	33.0	34.4	28.7	38.2	21.8
	90	39.6	39.6	40.3	37.5	44.4	30.1	37.5	37.5	37.9	36.3	41.5	28.7	35.1	35.1	35.2	34.9	38.6	27.2
1080	75	36.0	29.2	39.9	21.9	44.0	13.3	33.6	28.0	37.2	19.7	41.1	12.0	31.0	26.6	34.4	18.6	38.1	10.4
	80	36.8	36.2	40.4	27.8	44.6	18.9	34.5	34.5	37.7	26.3	41.7	19.2	32.2	32.2	34.9	24.8	38.7	17.2
	85	39.1	39.1	40.9	34.0	45.0	26.3	36.9	36.9	38.2	32.6	42.1	24.9	34.5	34.5	35.4	31.3	39.0	23.3
	90	41.5	41.5	41.7	40.9	45.4	32.2	39.2	39.2	39.2	39.2	42.5	30.8	36.8	36.8	36.7	36.7	39.4	29.1
1200	75	36.9	31.4	40.8	22.8	44.8	13.2	34.4	30.1	38.0	21.3	41.9	12.1	31.6	28.7	35.1	19.7	38.7	10.5
	80	38.1	38.1	41.2	29.4	45.4	21.7	35.8	35.8	38.5	27.9	42.5	19.4	33.4	33.4	35.6	26.4	39.4	18.3
	85	40.6	40.6	41.8	36.5	45.9	27.8	38.3	38.3	39.0	35.2	42.9	26.3	35.8	35.8	36.2	34.0	39.7	24.6
	90	43.1	43.1	43.1	43.1	46.3	34.2	40.7	40.7	40.7	40.7	43.3	32.6	38.2	38.2	38.1	38.1	40.2	31.1
1320	75	37.7	33.7	41.4	23.6	45.5	13.2	35.0	32.2	38.6	21.9	42.5	12.3	32.4	30.9	35.7	20.8	39.3	10.6
	80	39.3	39.3	41.9	31.1	46.3	22.5	37.0	37.0	39.2	29.6	43.1	20.5	34.4	34.4	36.2	28.2	39.9	19.0
	85	41.9	41.9	42.6	39.2	46.6	29.2	39.5	39.5	39.9	38.0	43.5	27.5	36.9	36.9	37.1	36.4	40.4	26.0
	90	44.5	44.5	44.5	44.5	47.1	36.1	42.1	42.1	42.0	42.0	44.0	34.8	39.4	39.4	39.4	39.4	40.9	33.5
1440	75	38.3	35.6	42.0	24.6	46.1	13.8	35.7	34.2	39.2	23.6	43.0	12.2	33.0	32.4	36.1	21.7	39.7	10.8
	80	40.4	40.4	42.6	32.7	46.8	21.5	38.0	38.0	39.8	31.4	43.7	21.0	35.4	35.4	36.7	30.0	40.4	19.5
	85	43.1	43.1	43.5	41.9	47.3	30.6	40.6	40.6	40.8	40.2	44.1	28.9	37.9	37.9	38.0	37.9	40.9	27.3
	90	45.8	45.8	45.8	45.8	47.7	38.3	43.3	43.3	43.2	43.2	44.7	37.2	40.5	40.5	40.5	40.5	41.5	36.0

**Notes:**

1. All capacities shown are gross and have not considered indoor fan heat. To obtain NET cooling capacity subtract indoor fan heat. For indoor fan heat formula, refer to appropriate airflow table notes.
2. MBh = Total gross capacity
3. SHC = Sensible heat capacity
4. Unit applications below 320 cfm/ton are only applicable on THC models without electric heat. Electric and gas heat applications are restricted to applications 320 cfm/ton and above.

*Note: Table continues on next page*



**Table 19. Gross cooling capacities 3 tons high efficiency — three phase T/YHC036E3,4,W (continued)**

CFM	Ent DB (°F)	Ambient Temperature (°F)						Ambient Temperature (°F)					
		115						125					
		Entering Wet Bulb Temp (°F)						Entering Wet Bulb Temp (°F)					
		61		67		73		61		67		73	
		MBh	SHC	MBh	SHC	MBh	SHC	MBh	SHC	MBh	SHC	MBh	SHC
600	75	23.4	18.8	26.8	13.4	31.4	4.9	20.9	17.2	24.0	12.0	28.5	3.8
	80	24.2	22.4	26.8	18.6	30.8	11.8	21.7	20.6	24.2	17.1	27.9	10.5
	85	25.3	25.1	27.3	23.0	30.6	17.8	22.9	22.9	24.7	21.3	27.8	16.4
	90	27.9	27.9	28.2	26.5	30.8	22.9	25.3	25.3	25.5	24.7	28.0	21.3
720	75	24.8	20.3	28.0	14.8	32.5	6.1	22.2	18.7	25.2	13.3	29.5	4.9
	80	25.7	24.1	28.2	20.2	32.1	13.1	23.2	22.3	25.4	18.6	29.1	11.8
	85	27.0	27.0	28.8	24.7	32.0	19.3	24.5	24.5	26.1	23.0	29.0	17.8
	90	29.5	29.5	29.8	28.4	32.3	24.6	26.9	26.9	27.1	26.5	29.4	23.0
840	75	26.0	21.8	29.0	16.0	33.4	7.1	23.4	20.0	26.2	14.5	30.3	5.9
	80	27.1	25.7	29.4	21.6	33.1	14.4	24.5	23.8	26.6	19.9	30.1	12.9
	85	28.5	28.5	30.2	26.3	33.2	20.7	25.9	25.9	27.4	24.5	30.2	19.1
	90	31.0	31.0	31.4	30.1	33.7	26.2	28.3	28.3	28.6	28.2	30.7	24.5
960	75	27.3	23.0	30.7	16.4	34.1	8.8	24.4	21.2	27.0	15.5	31.0	6.7
	80	28.4	28.4	31.1	21.6	34.5	13.9	25.6	25.2	27.6	21.1	30.9	13.9
	85	30.5	30.5	31.5	27.2	35.1	20.2	27.3	27.3	28.6	25.8	31.2	20.3
	90	32.7	32.7	32.6	32.6	35.4	25.5	29.6	29.6	29.9	29.7	31.9	25.8
1080	75	28.1	25.2	31.4	17.4	34.8	9.0	25.3	22.3	27.8	16.4	31.6	7.4
	80	29.7	29.7	31.8	23.2	35.4	16.0	26.7	26.4	28.5	22.1	31.7	14.8
	85	31.9	31.9	32.4	30.0	35.8	21.7	28.5	28.5	29.6	27.1	32.1	21.3
	90	34.1	34.1	34.1	34.1	36.2	27.5	30.8	30.8	31.1	31.1	32.9	27.0
1200	75	28.8	27.3	32.0	18.2	35.4	8.8	26.1	23.2	28.4	17.1	32.1	7.9
	80	30.8	30.8	32.5	25.0	36.0	16.4	27.6	27.5	29.3	23.0	32.3	15.5
	85	33.1	33.1	33.3	32.6	36.4	23.0	29.5	29.5	30.5	28.1	32.9	22.2
	90	35.4	35.4	35.4	35.4	36.9	29.8	32.2	32.2	32.2	32.2	33.8	28.1
1320	75	29.5	29.0	32.5	18.7	35.9	9.5	26.7	24.0	28.9	17.7	32.4	8.3
	80	31.8	31.8	33.0	26.8	36.5	17.2	28.4	28.4	29.9	23.8	32.8	16.1
	85	34.2	34.2	34.2	34.2	37.0	24.2	30.5	30.5	31.3	29.1	33.5	23.0
	90	36.6	36.6	36.5	36.5	37.5	32.2	33.1	33.1	33.1	33.1	34.6	29.0
1440	75	30.2	30.1	32.9	20.1	36.3	9.3	27.2	24.6	29.2	18.1	32.6	8.6
	80	32.6	32.6	33.5	28.8	36.9	17.9	29.0	29.0	30.4	24.4	33.1	16.5
	85	35.1	35.1	35.1	35.1	37.5	25.8	31.3	31.3	32.0	29.9	34.0	23.6
	90	37.5	37.5	37.5	37.5	38.1	34.8	33.9	33.9	33.9	33.9	35.3	29.8

**Notes:**

1. All capacities shown are gross and have not considered indoor fan heat. To obtain NET cooling capacity subtract indoor fan heat. For indoor fan heat formula, refer to appropriate airflow table notes.
2. MBh = Total gross capacity
3. SHC = Sensible heat capacity
4. Unit applications below 320 cfm/ton are only applicable on THC models without electric heat. Electric and gas heat applications are restricted to applications 320 cfm/ton and above.



# Gross Cooling Capacities

**Table 20. Gross cooling capacities 4 tons high efficiency — three phase T/YHC048E3,4,W**

CFM	Ent DB (°F)	Ambient Temperature (°F)						Ambient Temperature (°F)						Ambient Temperature (°F)					
		85						95						105					
		Entering Wet Bulb Temp (°F)						Entering Wet Bulb Temp (°F)						Entering Wet Bulb Temp (°F)					
		61		67		73		61		67		73		61		67		73	
MBh	SHC	MBh	SHC	MBh	SHC	MBh	SHC	MBh	SHC	MBh	SHC	MBh	SHC	MBh	SHC	MBh	SHC		
800	75	39.5	31.1	44.6	23.3	51.6	11.5	36.8	29.6	41.6	22.2	48.3	10.8	33.9	28.0	38.5	20.9	44.9	9.9
	80	40.3	36.2	44.5	30.6	50.6	21.0	37.6	34.5	41.6	29.3	47.4	20.0	34.8	32.7	38.5	27.8	44.0	18.9
	85	41.6	40.1	45.0	36.7	50.2	29.2	39.0	38.2	42.1	35.1	47.0	28.0	36.2	36.2	39.0	33.4	43.6	26.7
	90	43.5	42.9	45.9	41.6	50.2	36.3	40.9	40.8	43.0	39.8	47.0	34.9	38.1	38.1	39.9	37.9	43.7	33.3
960	75	41.5	33.1	46.4	25.1	53.2	13.0	38.7	31.5	43.4	23.8	49.9	12.1	35.7	29.8	40.1	22.5	46.3	11.1
	80	42.5	38.5	46.6	32.6	52.5	22.6	39.7	36.7	43.5	31.1	49.1	21.6	36.8	34.7	40.3	29.5	45.6	20.3
	85	44.0	42.6	47.2	38.9	52.2	31.1	41.3	40.6	44.2	37.2	48.9	29.8	38.4	38.4	41.0	35.4	45.4	28.4
	90	46.1	45.6	48.3	44.0	52.5	38.4	43.4	43.4	45.3	42.2	49.2	36.9	40.5	40.5	42.2	40.1	45.7	35.3
1120	75	43.3	35.0	48.1	26.7	54.7	14.3	40.4	33.3	44.9	25.3	51.3	13.3	37.4	31.5	41.6	23.8	47.6	12.2
	80	44.5	40.6	48.4	34.4	54.2	24.2	41.7	38.7	45.3	32.9	50.7	23.0	38.7	36.6	42.0	31.1	47.1	21.7
	85	46.3	45.0	49.2	41.0	54.1	32.9	43.4	42.9	46.1	39.2	50.7	31.5	40.4	40.4	42.8	37.3	47.1	29.9
	90	48.5	48.2	50.6	46.3	54.5	40.4	45.7	45.7	47.5	44.4	51.1	38.8	43.8	43.8	44.2	42.2	47.6	37.1
1280	75	45.4	36.1	50.5	26.4	55.8	16.0	42.5	34.5	47.2	24.7	52.3	15.2	39.3	32.9	43.8	22.9	48.7	13.1
	80	46.2	44.2	51.0	34.1	56.4	24.0	43.2	42.5	47.7	32.3	53.0	22.7	40.1	40.1	44.3	30.8	49.2	20.7
	85	48.3	48.3	51.5	41.7	56.9	31.7	45.7	45.7	48.2	40.0	53.4	30.0	42.8	42.8	44.8	38.4	49.7	28.3
	90	51.2	51.2	52.2	49.6	57.3	39.1	48.5	48.5	49.0	48.0	53.8	37.5	45.7	45.7	45.7	45.7	50.1	35.8
1440	75	46.7	38.9	51.7	27.7	57.1	16.8	43.6	37.3	48.4	26.5	53.5	15.0	40.4	35.7	44.9	24.2	49.7	13.3
	80	47.6	47.3	52.3	36.3	57.8	25.6	44.7	44.7	48.9	34.6	54.1	23.3	41.8	41.8	45.4	33.0	50.3	21.3
	85	50.5	50.5	52.9	45.0	58.3	33.4	47.7	47.7	49.5	43.3	54.6	31.9	44.8	44.8	46.0	41.8	50.8	30.3
	90	53.6	53.6	53.8	53.5	58.7	42.0	50.8	50.8	50.7	50.7	55.0	40.2	47.7	47.7	47.7	47.7	51.2	38.7
1600	75	47.8	41.6	52.8	29.5	58.2	16.6	44.6	40.0	49.4	27.3	54.5	15.0	41.3	38.3	45.8	25.9	50.6	13.4
	80	49.2	49.2	53.3	38.6	58.8	25.3	46.4	46.4	49.9	37.0	55.2	24.3	43.4	43.4	46.3	35.5	51.2	23.6
	85	52.4	52.4	54.0	48.2	59.4	35.5	49.5	49.5	50.6	46.7	55.7	33.8	46.4	46.4	47.1	45.3	51.7	32.3
	90	55.7	55.7	55.6	55.6	59.9	44.8	52.7	52.7	52.6	52.6	56.1	43.2	49.5	49.5	49.4	49.4	52.2	41.7
1760	75	48.8	44.2	53.7	30.6	59.2	16.8	45.5	42.6	50.2	28.8	55.4	15.2	42.1	40.8	46.5	27.3	51.4	13.6
	80	50.8	50.8	54.3	41.0	59.8	27.3	47.9	47.9	50.8	39.3	56.0	25.6	44.7	44.7	47.0	37.7	52.0	24.8
	85	54.1	54.1	55.1	51.6	60.3	37.5	51.1	51.1	51.7	50.1	56.5	35.9	47.9	47.9	48.0	47.8	52.5	34.3
	90	57.5	57.5	57.4	57.4	60.9	47.9	54.3	54.3	54.2	54.2	57.1	46.3	51.1	51.1	51.1	51.1	53.0	44.7
1920	75	49.6	46.9	54.5	31.8	60.0	16.9	46.3	45.0	50.9	30.2	56.1	15.5	42.9	42.6	47.1	28.6	52.0	13.7
	80	52.2	52.2	55.1	43.2	60.6	27.5	49.2	49.2	51.5	41.6	56.8	26.8	46.0	46.0	47.7	40.1	52.6	25.4
	85	55.6	55.6	56.1	54.7	61.2	39.5	52.5	52.5	52.7	52.5	57.2	37.9	49.2	49.2	49.2	49.2	53.1	36.3
	90	59.1	59.1	59.0	59.0	61.8	50.7	55.9	55.9	55.8	55.8	57.9	49.3	52.5	52.5	52.4	52.4	53.8	47.8

**Notes:**

1. All capacities shown are gross and have not considered indoor fan heat. To obtain NET cooling capacity subtract indoor fan heat. For indoor fan heat formula, refer to appropriate airflow table notes.
2. MBh = Total gross capacity
3. SHC = Sensible heat capacity
4. Unit applications below 320 cfm/ton are only applicable on THC models without electric heat. Electric and gas heat applications are restricted to applications 320 cfm/ton and above.

*Note: Table continues on next page*

Table 21. Gross cooling capacities 4 tons high efficiency — three phase T/YHC048E3,4,W (continued)

CFM	Ent DB (°F)	Ambient Temperature (°F)						Ambient Temperature (°F)					
		115						125					
		Entering Wet Bulb Temp (°F)						Entering Wet Bulb Temp (°F)					
		61		67		73		61		67		73	
		MBh	SHC	MBh	SHC	MBh	SHC	MBh	SHC	MBh	SHC	MBh	SHC
800	75	30.9	26.2	35.2	19.5	41.3	8.8	27.7	24.3	31.6	17.9	37.5	7.6
	80	31.8	30.7	35.2	26.1	40.4	17.6	28.6	28.5	31.7	24.3	36.6	16.2
	85	33.2	33.2	35.7	31.6	40.0	25.2	30.0	30.0	32.2	29.6	36.3	23.6
	90	36.3	36.3	36.7	35.8	40.1	31.6	33.3	33.3	33.3	33.3	36.4	29.8
960	75	32.6	27.9	36.7	20.9	42.6	10.0	29.3	25.8	33.1	19.2	38.7	8.6
	80	33.7	32.6	36.9	27.8	41.9	19.0	30.4	30.3	33.3	25.9	38.1	17.4
	85	35.3	35.3	37.6	33.5	41.7	26.8	32.0	32.0	34.0	31.3	37.9	25.0
	90	38.4	38.4	38.8	38.0	42.1	33.4	35.3	35.3	35.3	35.3	38.2	31.5
1120	75	34.2	29.5	38.1	22.2	43.8	10.9	30.8	27.3	34.4	20.4	39.9	9.5
	80	35.5	34.4	38.5	29.3	43.3	20.2	32.1	32.0	34.8	27.3	39.4	18.5
	85	37.2	37.2	39.4	35.2	43.3	28.2	33.9	33.9	35.7	33.0	39.4	26.4
	90	40.3	40.3	40.8	39.9	43.8	35.1	37.1	37.1	37.1	37.1	39.9	33.0
1280	75	35.9	31.2	40.1	21.3	44.7	11.5	32.1	28.6	35.5	21.4	40.8	10.2
	80	37.2	37.2	40.6	29.0	45.3	19.2	33.6	33.6	36.1	28.5	40.5	19.5
	85	39.8	39.8	41.1	36.7	45.7	26.7	35.6	35.6	37.2	34.5	40.7	27.6
	90	42.5	42.5	42.5	42.5	46.0	34.1	38.8	38.8	38.8	38.8	41.4	34.5
1440	75	36.9	34.0	41.1	22.7	45.7	11.6	33.2	29.8	36.5	22.3	41.6	10.8
	80	38.7	38.7	41.6	31.3	46.2	19.7	34.9	34.9	37.3	29.7	41.5	20.3
	85	41.6	41.6	42.2	40.2	46.7	28.7	37.1	37.1	38.5	35.8	41.9	28.7
	90	44.4	44.4	44.3	44.3	47.0	37.1	40.3	40.3	40.3	40.3	42.8	35.8
1600	75	37.7	36.6	41.8	24.1	46.4	11.8	34.2	30.9	37.2	23.1	42.2	11.3
	80	40.2	40.2	42.4	33.7	47.0	21.8	36.0	36.0	38.2	30.7	42.3	21.0
	85	43.1	43.1	43.3	43.0	47.5	30.7	38.4	38.4	39.7	37.1	42.9	29.6
	90	46.0	46.0	46.0	46.0	47.9	40.0	41.7	41.7	41.7	41.7	44.0	37.0
1760	75	38.5	38.4	42.5	25.6	47.1	12.0	35.0	31.8	37.9	23.7	42.6	11.6
	80	41.4	41.4	43.1	36.1	47.7	22.2	37.0	37.0	39.0	31.5	42.9	21.6
	85	44.4	44.4	44.4	44.4	48.1	32.7	39.6	39.6	40.7	38.2	43.7	30.4
	90	47.4	47.4	47.4	47.4	48.6	43.2	42.9	42.9	42.9	42.9	45.0	38.0
1920	75	39.3	39.3	43.0	26.9	47.7	12.5	35.6	32.6	38.3	24.2	42.9	11.8
	80	42.5	42.5	43.7	38.4	48.2	23.5	37.9	37.9	39.7	32.3	43.4	22.0
	85	45.6	45.6	45.5	45.5	48.7	34.7	40.6	40.6	41.6	39.1	44.4	31.1
	90	48.7	48.7	48.6	48.6	49.4	46.5	43.9	43.9	43.9	43.9	45.8	38.9

Notes:

1. All capacities shown are gross and have not considered indoor fan heat. To obtain NET cooling capacity subtract indoor fan heat. For indoor fan heat formula, refer to appropriate airflow table notes.
2. MBh = Total gross capacity
3. SHC = Sensible heat capacity
4. Unit applications below 320 cfm/ton are only applicable on THC models without electric heat. Electric and gas heat applications are restricted to applications 320 cfm/ton and above.



## Gross Cooling Capacities

Table 22. Gross cooling capacities 4 tons high efficiency — three phase T/YHC048F3,4,W

CFM	Ent DB (°F)	Ambient Temperature (°F)						Ambient Temperature (°F)						Ambient Temperature (°F)					
		85						95						105					
		Entering Wet Bulb Temp (°F)						Entering Wet Bulb Temp (°F)						Entering Wet Bulb Temp (°F)					
		61		67		73		61		67		73		61		67		73	
MBh	SHC	MBh	SHC	MBh	SHC	MBh	SHC	MBh	SHC	MBh	SHC	MBh	SHC	MBh	SHC	MBh	SHC		
800	75	38.6	28.5	43.5	21.3	50.0	10.6	36.1	27.0	40.8	20.0	47.1	9.7	33.5	25.3	37.9	18.6	43.9	8.5
	80	39.3	33.3	43.5	27.9	49.3	19.0	36.9	31.6	40.9	26.5	46.4	17.9	34.3	29.9	38.0	24.9	43.3	16.6
	85	40.5	37.2	44.0	33.5	49.0	26.4	38.2	35.4	41.4	32.0	46.1	25.1	35.6	33.5	38.6	30.3	43.1	23.7
	90	42.1	40.1	44.8	38.2	49.1	32.8	39.8	38.2	42.3	36.5	46.3	31.4	37.3	36.1	39.6	34.7	43.4	29.8
960	75	41.0	30.8	45.8	23.3	52.1	12.2	38.4	29.2	42.9	21.9	49.0	11.2	35.7	27.5	39.9	20.4	45.8	10.0
	80	42.0	35.9	46.0	30.1	51.6	20.9	39.5	34.2	43.2	28.6	48.6	19.7	36.8	32.3	40.3	27.0	45.4	18.3
	85	43.4	40.1	46.6	36.0	51.5	28.5	40.9	38.2	43.9	34.4	48.5	27.2	38.3	36.2	41.0	32.7	45.4	25.7
	90	45.2	43.3	47.7	41.0	51.8	35.2	42.8	41.3	45.0	39.2	48.9	33.7	40.2	39.1	42.2	37.3	45.8	32.1
1120	75	43.2	32.9	47.7	25.0	53.9	13.6	40.5	31.3	44.8	23.6	50.7	12.5	37.6	29.4	41.7	22.0	47.4	11.2
	80	44.4	38.3	48.2	32.1	53.6	22.5	41.7	36.5	45.3	30.6	50.5	21.2	38.9	34.5	42.3	28.9	47.2	19.8
	85	46.0	42.8	49.0	38.3	53.7	30.5	43.4	40.8	46.2	36.6	50.6	29.0	40.6	38.7	43.2	34.8	47.4	27.4
	90	48.0	46.2	50.3	43.6	54.2	37.5	45.5	44.1	47.6	41.7	51.2	35.9	42.8	41.9	44.6	39.8	48.0	34.2
1280	75	45.1	34.8	49.5	26.5	55.4	14.8	42.3	33.1	46.4	25.0	52.1	13.5	39.3	31.1	43.2	23.4	48.7	12.1
	80	46.5	40.5	50.1	34.0	55.3	24.0	43.7	38.6	47.1	32.3	52.1	22.6	40.8	36.5	44.0	30.5	48.7	21.0
	85	48.3	45.2	51.2	40.4	55.6	32.2	45.6	43.2	48.2	38.6	52.5	30.7	42.7	41.0	45.1	36.7	49.1	29.0
	90	50.5	49.0	52.6	45.9	56.4	39.5	47.9	46.8	49.8	44.0	53.3	37.8	45.1	44.5	46.7	41.9	50.0	36.0
1440	75	46.7	36.5	50.9	27.9	56.7	15.7	43.8	34.7	47.8	26.2	53.3	14.4	40.7	32.6	44.4	24.5	49.7	12.9
	80	48.3	42.5	51.7	35.5	56.8	25.2	45.5	40.5	48.7	33.8	53.5	23.7	42.4	38.3	45.4	31.9	49.9	22.1
	85	50.3	47.5	53.0	42.3	57.3	33.7	47.5	45.3	50.0	40.4	54.0	32.1	44.6	43.0	46.8	38.4	50.6	30.3
	90	52.7	51.5	54.7	48.1	58.3	41.2	50.0	49.2	51.7	46.1	55.1	39.5	47.1	46.8	48.6	43.9	51.7	37.6
1600	75	48.1	38.0	52.1	28.9	57.7	16.4	45.0	36.0	48.8	27.2	54.2	15.0	41.9	33.9	45.4	25.4	50.5	13.4
	80	49.9	44.2	53.1	36.9	58.0	26.2	46.9	42.1	49.9	35.1	54.5	24.6	43.8	39.9	46.6	33.1	50.9	22.9
	85	52.1	49.5	54.6	43.9	58.7	34.9	49.2	47.2	51.5	42.0	55.3	33.2	46.1	44.9	48.2	39.8	51.8	31.4
	90	54.7	53.8	56.5	50.0	59.9	42.8	51.9	51.4	53.4	47.9	56.6	40.9	48.9	48.9	50.2	45.6	53.1	38.9
1760	75	49.1	39.2	53.0	29.8	58.4	16.9	46.0	37.1	49.6	28.0	54.8	15.4	42.7	35.0	46.1	26.1	51.0	13.7
	80	51.1	45.7	54.2	38.0	58.9	26.9	48.1	43.5	50.9	36.1	55.4	25.3	44.8	41.2	47.4	34.0	51.6	23.5
	85	53.6	51.2	55.9	45.3	59.8	36.0	50.6	48.9	52.7	43.3	56.4	34.2	47.4	46.5	49.2	41.1	52.7	32.2
	90	56.4	55.8	58.0	51.7	61.2	44.1	53.5	53.4	54.8	49.5	57.8	42.2	50.4	50.4	51.5	47.1	54.2	40.1
1920	75	49.9	40.2	53.6	30.4	58.8	17.2	46.7	38.1	50.1	28.5	55.1	15.6	43.3	35.8	46.5	26.5	51.2	13.8
	80	52.2	47.0	55.1	39.0	59.5	27.5	49.0	44.7	51.6	36.9	55.9	25.7	45.6	42.3	48.1	34.8	52.1	23.8
	85	54.8	52.8	57.0	46.5	60.7	36.8	51.7	50.4	53.6	44.4	57.1	34.9	48.4	47.8	50.1	42.1	53.3	32.9
	90	57.9	57.7	59.3	53.2	62.3	45.2	54.8	54.8	56.0	50.9	58.7	43.2	51.6	51.6	52.5	48.4	55.0	41.0

**Notes:**

1. All capacities shown are gross and have not considered indoor fan heat. To obtain NET cooling capacity subtract indoor fan heat. For indoor fan heat formula, refer to appropriate airflow table notes.
2. MBh = Total gross capacity
3. SHC = Sensible heat capacity
4. Unit applications below 320 cfm/ton are only applicable on THC models without electric heat. Electric and gas heat applications are restricted to applications 320 cfm/ton and above.

*Note: Table continues on next page*

**Table 23. Gross cooling capacities 4 tons high efficiency — three phase T/YHC048F3,4,W (continued)**

CFM	Ent DB (°F)	Ambient Temperature (°F)						Ambient Temperature (°F)					
		115						125					
		Entering Wet Bulb Temp (°F)						Entering Wet Bulb Temp (°F)					
		61		67		73		61		67		73	
		MBh	SHC	MBh	SHC	MBh	SHC	MBh	SHC	MBh	SHC	MBh	SHC
800	75	30.6	23.5	34.8	17.1	40.6	7.2	27.6	21.6	31.6	15.4	37.1	5.8
	80	31.6	27.9	35.0	23.3	40.1	15.2	28.6	25.9	31.8	21.5	36.6	13.6
	85	32.9	31.4	35.6	28.5	39.9	22.1	30.0	29.2	32.5	26.5	36.5	20.4
	90	34.7	33.9	36.7	32.8	40.2	28.2	31.8	31.6	33.6	30.7	36.9	26.3
960	75	32.8	25.6	36.8	18.8	42.4	8.6	29.6	23.6	33.4	17.0	38.8	7.1
	80	33.9	30.3	37.2	25.3	42.0	16.8	30.8	28.1	33.9	23.4	38.5	15.1
	85	35.4	34.0	38.0	30.8	42.1	24.0	32.4	31.7	34.7	28.7	38.6	22.3
	90	37.4	36.8	39.2	35.3	42.6	30.3	34.5	34.4	36.0	33.1	39.2	28.4
1120	75	34.6	27.4	38.4	20.3	43.8	9.7	31.4	25.3	35.0	18.4	40.1	8.1
	80	35.9	32.4	39.0	27.0	43.7	18.2	32.8	30.2	35.6	25.0	40.0	16.4
	85	37.7	36.4	40.1	32.8	44.0	25.7	34.6	34.1	36.7	30.7	40.4	23.8
	90	39.9	39.5	41.5	37.6	44.7	32.3	36.8	36.8	38.2	35.4	41.2	30.3
1280	75	36.2	29.1	39.8	21.6	45.0	10.6	32.8	26.9	36.2	19.6	41.2	8.9
	80	37.7	34.3	40.6	28.6	45.1	19.4	34.4	32.0	37.1	26.5	41.4	17.5
	85	39.7	38.6	41.9	34.6	45.6	27.2	36.5	36.1	38.4	32.4	41.9	25.2
	90	42.1	42.0	43.5	39.7	46.5	34.0	38.9	38.9	40.1	37.4	42.9	31.9
1440	75	37.5	30.5	40.9	22.6	46.0	11.3	34.0	28.2	37.2	20.5	42.0	9.5
	80	39.2	36.0	41.9	29.9	46.3	20.3	35.8	33.6	38.3	27.7	42.4	18.4
	85	41.4	40.6	43.4	36.2	47.0	28.4	38.1	38.0	39.8	33.9	43.1	26.3
	90	44.0	44.0	45.3	41.6	48.1	35.5	40.7	40.7	41.7	39.1	44.3	33.3
1600	75	38.5	31.7	41.8	23.4	46.6	11.7	34.9	29.3	38.0	21.3	42.6	9.8
	80	40.5	37.5	43.0	31.0	47.1	21.0	37.0	34.9	39.3	28.7	43.1	19.0
	85	42.9	42.3	44.7	37.6	48.0	29.4	39.4	39.4	41.0	35.2	44.1	27.2
	90	45.7	45.7	46.7	43.2	49.4	36.8	42.3	42.3	43.1	40.7	45.5	34.5
1760	75	39.2	32.6	42.3	24.0	47.0	11.9	35.6	30.1	38.4	21.8	42.9	9.9
	80	41.4	38.7	43.8	31.8	47.7	21.5	37.8	36.1	39.9	29.5	43.6	19.4
	85	44.0	43.8	45.6	38.7	48.8	30.1	40.5	40.5	41.9	36.2	44.8	27.9
	90	47.0	47.0	47.9	44.7	50.4	37.8	43.6	43.6	44.2	42.0	46.4	35.5
1920	75	39.7	33.3	42.6	24.3	47.1	11.9	36.0	30.8	38.6	22.0	42.9	9.8
	80	42.1	39.7	44.3	32.5	48.0	21.8	38.4	37.0	40.3	30.0	43.8	19.6
	85	44.9	44.9	46.4	39.6	49.4	30.7	41.3	41.3	42.5	37.0	45.2	28.4
	90	48.2	48.2	48.9	45.8	51.1	38.7	44.6	44.6	45.0	43.1	47.0	36.2

**Notes:**

1. All capacities shown are gross and have not considered indoor fan heat. To obtain NET cooling capacity subtract indoor fan heat. For indoor fan heat formula, refer to appropriate airflow table notes.
2. MBh = Total gross capacity
3. SHC = Sensible heat capacity
4. Unit applications below 320 cfm/ton are only applicable on THC models without electric heat. Electric and gas heat applications are restricted to applications 320 cfm/ton and above.



## Gross Cooling Capacities

**Table 24. Gross cooling capacities 5 tons high efficiency — three phase T/YHC060E3,4,W**

CFM	Ent DB (°F)	Ambient Temperature (°F)						Ambient Temperature (°F)						Ambient Temperature (°F)					
		85						95						105					
		Entering Wet Bulb Temp (°F)						Entering Wet Bulb Temp (°F)						Entering Wet Bulb Temp (°F)					
		61		67		73		61		67		73		61		67		73	
MBh	SHC	MBh	SHC	MBh	SHC	MBh	SHC	MBh	SHC	MBh	SHC	MBh	SHC	MBh	SHC	MBh	SHC		
1000	75	50.6	39.4	57.2	29.5	66.2	14.8	47.3	37.5	53.5	28.1	62.2	13.9	43.8	35.5	49.7	26.6	58.0	12.7
	80	51.5	45.7	57.0	38.5	64.8	26.5	48.2	43.6	53.3	36.9	60.8	25.2	44.8	41.4	49.5	35.1	56.6	23.8
	85	53.1	50.7	57.4	46.1	64.0	36.6	49.8	48.3	53.8	44.2	60.1	35.1	46.4	45.8	50.0	42.1	55.9	33.5
	90	55.3	54.1	58.5	52.1	64.0	45.3	52.1	51.5	54.9	50.0	60.0	43.6	48.7	48.7	51.1	47.6	55.9	41.7
1200	75	53.1	42.1	59.5	31.9	68.2	17.0	49.7	40.1	55.7	30.4	64.1	15.8	46.1	38.0	51.7	28.7	59.8	14.6
	80	54.3	48.7	59.5	41.2	67.0	28.9	50.8	46.5	55.7	39.4	62.9	27.5	47.3	44.1	51.8	37.5	58.7	26.0
	85	56.1	53.9	60.1	49.0	66.5	39.3	52.7	51.4	56.4	47.0	62.5	37.7	49.2	48.8	52.5	44.8	58.2	35.9
	90	58.5	57.6	61.4	55.4	66.7	48.3	55.2	54.9	57.7	53.1	62.6	46.4	51.7	51.7	53.9	50.6	58.5	44.3
1400	75	55.4	44.6	61.5	34.2	70.0	18.9	51.8	42.5	57.6	32.5	65.8	17.6	48.1	40.3	53.6	30.7	61.4	16.2
	80	56.8	51.5	61.7	43.7	69.1	31.1	53.3	49.2	57.9	41.8	64.9	29.6	49.6	46.7	53.9	39.7	60.5	27.9
	85	58.8	57.0	62.6	51.8	68.8	41.8	55.3	54.4	58.8	49.6	64.6	40.0	51.7	51.6	54.8	47.3	60.3	38.1
	90	61.5	61.0	64.2	58.4	69.2	51.0	58.1	58.1	60.4	56.0	65.1	49.0	54.5	54.5	56.4	53.4	60.8	46.8
1600	75	58.0	46.3	64.5	34.2	71.3	22.4	54.3	44.3	60.5	32.5	67.1	21.0	50.4	42.2	56.3	30.5	62.5	18.4
	80	58.7	55.9	64.8	43.5	71.8	31.7	55.0	53.9	60.9	41.7	67.6	29.9	51.3	51.3	56.7	39.7	63.1	27.9
	85	61.3	61.3	65.3	53.0	72.2	41.1	58.1	58.1	61.3	51.0	67.9	39.0	54.7	54.7	57.1	49.0	63.4	37.0
	90	64.9	64.9	65.8	62.4	72.6	50.2	61.6	61.6	61.9	60.6	68.3	47.9	58.1	58.1	58.0	58.0	63.7	46.0
1800	75	59.6	49.6	66.0	35.9	72.9	22.5	55.7	47.5	61.9	34.5	68.5	20.7	51.7	45.4	57.5	32.4	63.8	18.6
	80	60.5	60.3	66.4	46.6	73.5	33.3	57.1	57.1	62.3	44.5	69.0	31.2	53.5	53.5	58.0	42.6	64.3	29.3
	85	64.1	64.1	66.9	57.0	73.9	43.4	60.7	60.7	62.8	55.1	69.4	41.5	57.1	57.1	58.5	53.1	64.7	39.4
	90	67.8	67.8	67.9	67.7	74.2	53.6	64.3	64.3	64.3	64.3	69.8	51.4	60.6	60.6	60.6	60.6	65.1	49.6
2000	75	60.8	52.8	67.3	37.9	74.2	22.9	56.9	50.8	63.0	35.7	69.6	21.2	52.8	48.7	58.6	33.8	64.9	19.0
	80	62.6	62.6	67.7	49.4	74.8	34.6	59.1	59.1	63.5	47.3	70.2	32.6	55.4	55.4	59.0	45.4	65.4	30.5
	85	66.5	66.5	68.4	61.1	75.2	45.8	62.9	62.9	64.2	59.2	70.6	43.8	59.2	59.2	59.7	57.2	65.8	41.8
	90	70.4	70.4	70.3	70.3	75.5	57.1	66.8	66.8	66.7	66.7	71.0	55.2	62.9	62.9	62.8	62.8	66.2	53.2
2200	75	61.9	56.0	68.3	39.5	75.3	23.3	58.0	54.1	64.0	37.9	70.6	21.0	53.8	52.0	59.4	35.3	65.8	19.1
	80	64.5	64.5	68.8	52.2	75.9	35.9	60.9	60.9	64.6	50.2	71.2	33.9	57.2	57.2	60.0	48.2	66.3	31.9
	85	68.5	68.5	69.5	65.2	76.3	48.4	64.9	64.9	65.3	63.4	71.7	46.3	61.0	61.0	61.0	60.9	66.7	44.3
	90	72.6	72.6	72.6	72.6	76.8	60.8	68.9	68.9	68.8	68.8	72.1	58.8	64.8	64.8	64.8	64.8	67.2	56.9
2400	75	62.9	59.3	69.2	41.2	76.1	22.9	58.9	57.3	64.8	39.1	71.4	21.7	54.8	54.7	60.2	37.0	66.5	19.5
	80	66.2	66.2	69.8	55.0	76.9	37.1	62.5	62.5	65.4	53.0	72.1	35.1	58.6	58.6	60.8	51.0	67.1	33.0
	85	70.4	70.4	70.8	69.3	77.3	51.0	66.6	66.6	66.7	66.6	72.5	48.5	62.6	62.6	62.5	62.5	67.6	46.8
	90	74.6	74.6	74.5	74.5	77.8	64.3	70.7	70.7	70.7	70.7	72.9	62.5	66.6	66.6	66.5	66.5	68.2	60.7

**Notes:**

1. All capacities shown are gross and have not considered indoor fan heat. To obtain NET cooling capacity subtract indoor fan heat. For indoor fan heat formula, refer to appropriate airflow table notes.
2. MBh = Total gross capacity
3. SHC = Sensible heat capacity
4. Unit applications below 320 cfm/ton are only applicable on THC models without electric heat. Electric and gas heat applications are restricted to applications 320 cfm/ton and above.

*Note: Table continues on next page*

**Table 25. Gross cooling capacities 5 tons high efficiency — three phase T/YHC060E3,4,W (continued)**

CFM	Ent DB (°F)	Ambient Temperature (°F)						Ambient Temperature (°F)					
		115						125					
		Entering Wet Bulb Temp (°F)						Entering Wet Bulb Temp (°F)					
		61		67		73		61		67		73	
		MBh	SHC	MBh	SHC	MBh	SHC	MBh	SHC	MBh	SHC	MBh	SHC
1000	75	40.1	33.4	45.7	24.9	53.6	11.4	36.3	31.1	41.5	23.0	49.0	10.0
	80	41.1	39.0	45.5	33.1	52.3	22.3	37.3	36.5	41.4	31.0	47.8	20.6
	85	42.8	42.8	46.0	39.8	51.6	31.7	39.0	39.0	41.9	37.5	47.2	29.7
	90	46.8	46.8	47.2	45.1	51.7	39.6	42.7	42.7	43.1	42.5	47.3	37.4
1200	75	42.3	35.7	47.6	26.9	55.3	13.2	38.3	33.3	43.3	24.9	50.7	11.6
	80	43.5	41.6	47.7	35.4	54.2	24.3	39.6	38.9	43.4	33.1	49.6	22.5
	85	45.5	45.5	48.4	42.4	53.8	33.9	41.6	41.6	44.2	39.9	49.3	31.9
	90	49.4	49.4	49.9	48.0	54.1	42.1	45.2	45.2	45.7	45.2	49.6	39.8
1400	75	44.2	37.9	49.3	28.7	56.8	14.7	40.2	35.3	44.9	26.6	52.0	13.0
	80	45.7	44.0	49.7	37.5	56.0	26.1	41.7	41.2	45.3	35.1	51.3	24.1
	85	47.9	47.9	50.7	44.8	55.8	36.0	43.9	43.9	46.3	42.1	51.1	33.8
	90	51.8	51.8	52.3	50.6	56.3	44.5	47.6	47.6	48.0	47.7	51.7	42.0
1600	75	46.3	40.0	51.8	28.3	57.7	16.5	41.9	37.1	46.4	28.1	53.2	14.2
	80	47.8	47.8	52.2	37.5	58.2	25.8	43.6	43.3	47.0	36.9	52.7	25.6
	85	51.0	51.0	52.6	46.9	58.5	35.0	46.1	46.1	48.2	44.2	52.8	35.6
	90	54.3	54.3	54.3	54.3	58.9	44.0	49.7	49.7	50.2	50.1	53.6	44.1
1800	75	47.4	43.3	52.9	30.0	58.9	16.7	43.3	38.7	47.6	29.4	54.2	15.2
	80	49.8	49.8	53.4	40.3	59.4	27.1	45.3	45.2	48.4	38.5	53.9	26.9
	85	53.3	53.3	54.0	51.0	59.8	37.2	48.0	48.0	49.9	46.1	54.3	37.2
	90	56.7	56.7	56.7	56.7	60.1	47.7	52.1	52.1	52.1	52.1	55.3	45.9
2000	75	48.5	46.5	53.8	31.6	59.8	17.0	44.6	40.2	48.6	30.6	55.0	16.1
	80	51.6	51.6	54.4	43.2	60.4	28.5	46.8	46.8	49.7	39.9	54.9	28.1
	85	55.2	55.2	55.3	55.1	60.7	40.2	49.7	49.7	51.4	47.8	55.5	38.6
	90	58.7	58.7	58.7	58.7	61.2	51.3	53.8	53.8	53.8	53.8	56.8	47.6
2200	75	49.4	49.3	54.6	33.2	60.6	17.3	45.6	41.5	49.4	31.6	55.6	16.8
	80	53.1	53.1	55.2	46.0	61.1	29.8	48.1	48.1	50.7	41.2	55.7	29.0
	85	56.8	56.8	56.8	56.8	61.6	42.5	51.2	51.2	52.7	49.3	56.5	39.8
	90	60.6	60.6	60.5	60.5	62.1	55.1	55.3	55.3	55.3	55.3	58.0	49.1
2400	75	50.7	50.7	55.3	35.0	61.3	17.5	46.4	42.6	50.0	32.4	55.9	17.3
	80	54.5	54.5	55.9	49.0	61.8	31.1	49.1	49.1	51.5	42.2	56.3	29.8
	85	58.3	58.3	58.2	58.2	62.3	44.9	52.5	52.5	53.7	50.7	57.4	40.8
	90	62.2	62.2	62.1	62.1	62.9	58.8	56.6	56.6	56.6	56.6	59.1	50.4

**Notes:**

1. All capacities shown are gross and have not considered indoor fan heat. To obtain NET cooling capacity subtract indoor fan heat. For indoor fan heat formula, refer to appropriate airflow table notes.
2. MBh = Total gross capacity
3. SHC = Sensible heat capacity
4. Unit applications below 320 cfm/ton are only applicable on THC models without electric heat. Electric and gas heat applications are restricted to applications 320 cfm/ton and above.



# Gross Cooling Capacities

**Table 26. Gross cooling capacities 5 tons high efficiency — three phase T/YHC060F3,4,W**

CFM	Ent DB (°F)	Ambient Temperature (°F)						Ambient Temperature (°F)						Ambient Temperature (°F)					
		85						95						105					
		Entering Wet Bulb Temp (°F)						Entering Wet Bulb Temp (°F)						Entering Wet Bulb Temp (°F)					
		61		67		73		61		67		73		61		67		73	
MBh	SHC	MBh	SHC	MBh	SHC	MBh	SHC	MBh	SHC	MBh	SHC	MBh	SHC	MBh	SHC	MBh	SHC		
1000	75	48.4	37.7	54.4	28.8	62.5	15.5	45.5	35.9	51.2	27.3	59.1	14.3	42.3	34.0	47.8	25.7	55.4	13.0
	80	49.1	43.6	54.1	36.9	61.3	25.8	46.3	41.7	51.1	35.3	58.0	24.6	43.3	39.6	47.8	33.6	54.5	23.2
	85	50.3	48.3	54.3	43.8	60.5	34.9	47.6	46.2	51.4	42.0	57.4	33.5	44.8	44.1	48.4	40.2	54.1	32.0
	90	51.9	51.7	55.0	49.4	60.2	42.8	49.4	49.4	52.3	47.6	57.3	41.3	46.8	46.8	49.4	45.6	54.1	39.7
1200	75	51.1	40.5	56.8	31.2	64.7	17.6	48.0	38.6	53.5	29.6	61.2	16.3	44.8	36.6	50.0	27.9	57.4	15.0
	80	52.0	46.7	56.8	39.6	63.7	28.2	49.1	44.7	53.6	37.9	60.3	26.9	46.0	42.5	50.3	36.1	56.8	25.4
	85	53.4	51.7	57.2	46.8	63.2	37.6	50.7	49.5	54.3	45.0	60.0	36.1	47.8	47.2	51.1	43.0	56.6	34.5
	90	55.3	55.3	58.2	52.7	63.2	45.8	52.7	52.7	55.3	50.8	60.1	44.2	50.0	50.0	52.4	48.7	56.9	42.4
1400	75	53.4	43.1	58.9	33.4	66.6	19.4	50.3	41.1	55.6	31.7	63.0	18.1	47.0	39.0	52.0	29.9	59.2	16.6
	80	54.6	49.6	59.2	42.1	65.9	30.3	51.6	47.4	55.9	40.3	62.4	28.9	48.5	45.2	52.5	38.4	58.7	27.3
	85	56.3	54.8	59.9	49.6	65.6	40.0	53.4	52.5	56.8	47.7	62.3	38.5	50.4	50.2	53.5	45.6	58.8	36.7
	90	58.4	58.4	61.0	55.8	65.8	48.5	55.7	55.7	58.1	53.8	62.7	46.8	52.9	52.9	55.0	51.6	59.3	45.0
1600	75	55.5	45.3	60.8	35.3	68.2	21.0	52.3	43.3	57.3	33.6	64.5	19.5	48.8	41.0	53.6	31.7	60.6	18.0
	80	56.9	52.1	61.2	44.3	67.7	32.2	53.8	49.9	57.9	42.4	64.1	30.6	50.6	47.6	54.4	40.4	60.4	29.0
	85	58.8	57.6	62.2	52.1	67.7	42.2	55.9	55.3	59.0	50.1	64.3	40.5	52.8	52.8	55.7	47.9	60.7	38.7
	90	61.2	61.2	63.6	58.6	68.1	50.9	58.5	58.5	60.6	56.5	64.9	49.1	55.6	55.6	57.4	54.2	61.5	47.2
1800	75	57.3	47.3	62.3	37.0	69.5	22.3	53.9	45.2	58.7	35.1	65.7	20.7	50.4	42.8	55.0	33.1	61.7	19.1
	80	58.9	54.4	63.0	46.2	69.2	33.8	55.8	52.1	59.6	44.3	65.6	32.1	52.4	49.6	56.0	42.2	61.8	30.3
	85	61.1	60.2	64.2	54.3	69.5	44.0	58.1	57.8	61.0	52.2	66.0	42.3	54.9	54.9	57.5	50.0	62.3	40.4
	90	63.7	63.7	65.9	61.1	70.2	53.1	60.9	60.9	62.8	58.9	66.9	51.2	57.9	57.9	59.6	56.5	63.4	49.2
2000	75	58.7	49.1	63.5	38.3	70.5	23.3	55.3	46.8	59.9	36.4	66.6	21.7	51.7	44.4	56.0	34.3	62.5	19.9
	80	60.6	56.4	64.5	47.9	70.5	35.1	57.4	54.0	61.0	45.8	66.8	33.3	54.0	51.5	57.3	43.6	62.9	31.5
	85	63.0	62.5	65.9	56.2	71.0	45.7	60.0	60.0	62.6	54.0	67.4	43.8	56.7	56.7	59.1	51.7	63.7	41.8
	90	65.9	65.9	67.9	63.3	71.9	55.0	63.0	63.0	64.7	61.0	68.5	53.0	59.9	59.9	61.4	58.6	65.0	50.9
2200	75	59.9	50.5	64.5	39.4	71.2	24.0	56.4	48.1	60.7	37.4	67.2	22.3	52.7	45.6	56.8	35.2	63.1	20.5
	80	62.1	58.1	65.7	49.3	71.4	36.1	58.7	55.7	62.1	47.1	67.6	34.3	55.2	53.0	58.4	44.8	63.6	32.3
	85	64.7	64.5	67.4	57.9	72.2	47.0	61.6	61.6	64.0	55.6	68.5	45.0	58.2	58.2	60.4	53.2	64.7	42.9
	90	67.9	67.9	69.5	65.3	73.4	56.6	64.9	64.9	66.3	62.9	69.9	54.5	61.7	61.7	62.9	60.4	66.2	52.3
2400	75	60.8	51.7	65.1	40.3	71.6	24.5	57.2	49.2	61.3	38.1	67.5	22.7	53.4	46.6	57.3	35.8	63.3	20.7
	80	63.2	59.6	66.6	50.4	72.1	36.9	59.8	57.0	62.9	48.2	68.2	35.0	56.2	54.3	59.1	45.8	64.1	32.9
	85	66.1	66.1	68.5	59.3	73.1	48.0	62.8	62.8	65.0	57.0	69.4	46.0	59.4	59.4	61.3	54.4	65.4	43.8
	90	69.5	69.5	70.9	67.0	74.6	57.9	66.4	66.4	67.6	64.5	71.0	55.8	63.1	63.1	64.1	61.9	67.2	53.5

**Notes:**

1. All capacities shown are gross and have not considered indoor fan heat. To obtain NET cooling capacity subtract indoor fan heat. For indoor fan heat formula, refer to appropriate airflow table notes.
2. MBh = Total gross capacity
3. SHC = Sensible heat capacity
4. Unit applications below 320 cfm/ton are only applicable on THC models without electric heat. Electric and gas heat applications are restricted to applications 320 cfm/ton and above.

*Note: Table continues on next page*



**Table 27. Gross cooling capacities 5 tons high efficiency — three phase T/YHC060F3,4,W (continued)**

CFM	Ent DB (°F)	Ambient Temperature (°F)						Ambient Temperature (°F)					
		115						125					
		Entering Wet Bulb Temp (°F)						Entering Wet Bulb Temp (°F)					
		61		67		73		61		67		73	
		MBh	SHC	MBh	SHC	MBh	SHC	MBh	SHC	MBh	SHC	MBh	SHC
1000	75	39.0	31.9	44.2	23.9	51.6	11.6	35.5	29.7	40.5	22.0	47.6	10.1
	80	40.1	37.4	44.4	31.7	50.9	21.6	36.8	35.1	40.8	29.7	47.0	20.0
	85	41.8	41.7	45.1	38.2	50.6	30.4	38.6	38.6	41.7	36.1	46.9	28.6
	90	43.9	43.9	46.3	43.5	50.8	37.9	42.6	42.6	43.0	41.2	47.3	36.0
1200	75	41.4	34.4	46.4	26.1	53.5	13.4	37.8	32.1	42.5	24.1	49.4	11.8
	80	42.8	40.3	46.8	34.2	53.0	23.7	39.4	37.8	43.2	32.1	49.1	22.0
	85	44.7	44.7	47.8	41.0	53.0	32.8	41.4	41.4	44.3	38.7	49.2	30.9
	90	47.1	47.1	49.2	46.5	53.5	40.6	45.4	45.4	45.8	44.2	49.9	38.6
1400	75	43.5	36.7	48.2	28.0	55.2	15.0	39.8	34.3	44.3	25.9	51.0	13.3
	80	45.1	42.8	48.9	36.3	54.9	25.6	41.6	40.3	45.2	34.1	50.9	23.7
	85	47.3	47.3	50.1	43.4	55.1	34.9	43.9	43.9	46.5	41.1	51.3	32.9
	90	49.9	49.9	51.8	49.3	55.8	43.0	47.9	47.9	48.4	46.9	52.2	40.9
1600	75	45.3	38.7	49.8	29.6	56.5	16.3	41.5	36.2	45.8	27.5	52.2	14.4
	80	47.2	45.1	50.8	38.3	56.5	27.1	43.6	42.4	46.9	36.0	52.4	25.2
	85	49.6	49.6	52.2	45.7	57.0	36.8	46.1	46.1	48.5	43.2	53.0	34.7
	90	52.5	52.5	54.1	51.8	57.9	45.1	50.1	50.1	50.6	49.3	54.2	42.9
1800	75	46.8	40.4	51.1	31.0	57.5	17.3	42.9	37.8	47.0	28.7	53.2	15.3
	80	48.9	47.1	52.3	39.9	57.8	28.4	45.2	44.4	48.3	37.5	53.6	26.4
	85	51.6	51.6	54.0	47.6	58.5	38.3	48.1	48.1	50.2	45.1	54.5	36.2
	90	54.7	54.7	56.1	54.0	59.7	47.0	52.0	52.0	52.5	51.4	55.9	44.7
2000	75	48.0	41.8	52.0	32.1	58.3	18.0	44.0	39.1	47.9	29.7	53.9	16.0
	80	50.4	48.8	53.5	41.3	58.8	29.5	46.6	46.0	49.5	38.8	54.5	27.3
	85	53.3	53.3	55.4	49.3	59.7	39.7	49.7	49.7	51.6	46.7	55.6	37.4
	90	57.3	57.3	57.9	56.0	61.2	48.6	53.6	53.6	54.2	53.3	57.3	46.2
2200	75	48.9	43.0	52.7	32.9	58.7	18.5	44.9	40.2	48.5	30.4	54.2	16.4
	80	51.6	50.3	54.4	42.4	59.5	30.2	47.7	47.3	50.3	39.8	55.1	28.0
	85	54.7	54.7	56.6	50.7	60.7	40.7	51.0	51.0	52.7	48.0	56.5	38.3
	90	58.7	58.7	59.3	57.7	62.4	50.0	55.0	55.0	55.5	54.9	58.4	47.5
2400	75	49.5	43.9	53.1	33.4	58.9	18.7	45.4	41.0	48.8	30.9	54.3	16.4
	80	52.4	51.4	55.1	43.2	59.9	30.7	48.5	48.4	50.9	40.6	55.4	28.4
	85	55.8	55.8	57.5	51.8	61.3	41.5	52.0	52.0	53.5	49.0	57.1	39.0
	90	59.8	59.8	60.4	59.1	63.3	51.0	56.0	56.0	56.6	56.2	59.2	48.5

**Notes:**

1. All capacities shown are gross and have not considered indoor fan heat. To obtain NET cooling capacity subtract indoor fan heat. For indoor fan heat formula, refer to appropriate airflow table notes.
2. MBh = Total gross capacity
3. SHC = Sensible heat capacity
4. Unit applications below 320 cfm/ton are only applicable on THC models without electric heat. Electric and gas heat applications are restricted to applications 320 cfm/ton and above.



# Gross Cooling Capacities

**Table 28. Gross cooling capacities 6 tons high efficiency — three phase T/YHC072F3,4,W**

CFM	Ent DB (°F)	Ambient Temperature (°F)						Ambient Temperature (°F)						Ambient Temperature (°F)					
		85						95						105					
		Entering Wet Bulb Temp (°F)						Entering Wet Bulb Temp (°F)						Entering Wet Bulb Temp (°F)					
		61		67		73		61		67		73		61		67		73	
MBh	SHC	MBh	SHC	MBh	SHC	MBh	SHC	MBh	SHC	MBh	SHC	MBh	SHC	MBh	SHC	MBh	SHC		
1200	75	57.4	45.1	64.4	34.6	73.9	19.0	54.0	43.2	60.8	33.0	70.0	17.8	50.4	41.0	56.8	31.2	65.7	16.4
	80	58.2	52.1	64.1	44.2	72.3	31.2	55.0	50.0	60.6	42.5	68.6	29.9	51.5	47.7	56.8	40.5	64.4	28.3
	85	59.6	57.7	64.2	52.3	71.3	41.9	56.6	55.4	60.9	50.5	67.7	40.5	53.2	52.9	57.2	48.4	63.7	38.8
	90	61.5	61.5	65.0	59.0	70.8	51.2	58.6	58.6	61.8	57.0	67.4	49.6	55.4	55.4	58.3	54.7	63.6	47.7
1440	75	60.6	48.5	67.3	37.5	76.5	21.5	57.1	46.4	63.6	35.8	72.5	20.2	53.4	44.1	59.5	33.9	68.1	18.7
	80	61.6	55.8	67.2	47.4	75.2	34.0	58.4	53.6	63.6	45.6	71.3	32.6	54.8	51.1	59.7	43.6	67.1	30.9
	85	63.3	61.6	67.6	55.9	74.4	45.0	60.2	59.2	64.2	53.9	70.7	43.5	56.7	56.6	60.4	51.7	66.6	41.7
	90	65.5	65.5	68.6	62.8	74.2	54.6	62.5	62.5	65.3	60.7	70.6	52.9	59.2	59.2	61.7	58.3	66.7	50.9
1680	75	63.4	51.5	69.8	40.1	78.7	23.7	59.8	49.3	66.0	38.3	74.6	22.3	56.0	46.9	61.8	36.3	70.1	20.7
	80	64.7	59.1	69.9	50.3	77.6	36.5	61.3	56.8	66.3	48.4	73.7	35.0	57.6	54.2	62.3	46.2	69.4	33.2
	85	66.6	65.2	70.6	59.1	77.1	47.8	63.4	62.7	67.1	57.0	73.3	46.1	59.8	59.8	63.3	54.7	69.2	44.3
	90	69.0	69.0	71.9	66.3	77.1	57.7	66.0	66.0	68.5	64.1	73.5	55.8	62.6	62.6	64.8	61.6	69.5	53.8
1920	75	65.8	54.2	71.9	42.4	80.5	25.5	62.2	51.9	68.0	40.5	76.3	24.1	58.2	49.4	63.8	38.4	71.8	22.4
	80	67.4	62.1	72.3	52.9	79.7	38.7	63.9	59.7	68.6	50.9	75.7	37.0	60.1	57.0	64.5	48.6	71.3	35.2
	85	69.5	68.5	73.3	61.9	79.4	50.3	66.2	65.9	69.7	59.8	75.5	48.5	62.6	62.6	65.7	57.3	71.3	46.5
	90	72.2	72.2	74.7	69.5	79.7	60.4	69.0	69.0	71.3	67.2	76.0	58.5	65.6	65.6	67.5	64.6	71.9	56.4
2160	75	67.8	56.6	73.7	44.4	82.0	27.1	64.1	54.2	69.7	42.4	77.7	25.5	60.1	51.6	65.4	40.2	73.1	23.7
	80	69.7	64.8	74.3	55.2	81.4	40.5	66.1	62.2	70.5	53.0	77.3	38.8	62.2	59.5	66.3	50.7	72.8	36.8
	85	72.1	71.5	75.5	64.5	81.4	52.4	68.7	68.7	71.8	62.2	77.4	50.6	64.9	64.9	67.8	59.7	73.1	48.5
	90	75.0	75.0	77.2	72.4	81.9	62.9	71.7	71.7	73.7	69.9	78.1	60.9	68.2	68.2	69.8	67.2	73.9	58.6
2400	75	69.5	58.6	75.1	46.0	83.0	28.4	65.7	56.1	71.0	43.9	78.7	26.7	61.6	53.4	66.5	41.6	74.0	24.8
	80	71.6	67.1	75.9	57.1	82.7	42.1	67.9	64.5	72.0	54.9	78.5	40.2	64.0	61.6	67.7	52.4	74.0	38.2
	85	74.2	74.2	77.4	66.8	83.0	54.3	70.7	70.7	73.6	64.4	78.9	52.3	66.9	66.9	69.5	61.7	74.5	50.1
	90	77.4	77.4	79.4	74.9	83.8	65.0	74.1	74.1	75.7	72.3	79.8	62.9	70.4	70.4	71.8	69.6	75.6	60.5
2640	75	70.8	60.4	76.0	47.4	83.7	29.3	66.9	57.8	71.9	45.2	79.3	27.5	62.7	55.0	67.4	42.8	74.5	25.5
	80	73.1	69.2	77.2	58.8	83.7	43.3	69.4	66.4	73.2	56.4	79.4	41.3	65.3	63.5	68.8	53.8	74.7	39.2
	85	76.0	76.0	78.9	68.7	84.2	55.8	72.4	72.4	75.0	66.2	80.0	53.7	68.5	68.5	70.8	63.5	75.5	51.4
	90	79.5	79.5	81.1	77.1	85.2	66.8	76.0	76.0	77.4	74.5	81.2	64.6	72.6	72.6	73.3	71.6	76.9	62.1
2880	75	71.7	61.8	76.7	48.4	84.1	29.9	67.7	59.1	72.4	46.1	79.5	28.0	63.4	56.2	67.8	43.6	74.6	25.9
	80	74.3	70.9	78.1	60.1	84.3	44.2	70.5	68.1	73.9	57.6	79.8	42.2	66.3	65.0	69.5	55.0	75.1	39.9
	85	77.4	77.4	80.0	70.3	85.0	57.0	73.8	73.8	76.0	67.7	80.7	54.8	69.8	69.8	71.7	64.9	76.2	52.4
	90	81.1	81.1	82.5	79.0	86.3	68.4	77.6	77.6	78.7	76.3	82.2	66.0	73.8	73.8	74.5	73.3	77.7	63.4

**Notes:**

1. All capacities shown are gross and have not considered indoor fan heat. To obtain NET cooling capacity subtract indoor fan heat. For indoor fan heat formula, refer to appropriate airflow table notes.
2. MBh = Total gross capacity
3. SHC = Sensible heat capacity
4. Unit applications below 320 cfm/ton are only applicable on THC models without electric heat. Electric and gas heat applications are restricted to applications 320 cfm/ton and above.

**Note:** Table continues on next page

**Table 29. Gross cooling capacities 6 tons high efficiency — three phase T/YHC072F3,4,W (continued)**

CFM	Ent DB (°F)	Ambient Temperature (°F)						Ambient Temperature (°F)					
		115						125					
		Entering Wet Bulb Temp (°F)						Entering Wet Bulb Temp (°F)					
		61		67		73		61		67		73	
		MBh	SHC	MBh	SHC	MBh	SHC	MBh	SHC	MBh	SHC	MBh	SHC
1200	75	46.4	38.6	52.5	29.2	61.1	14.8	42.0	35.9	47.9	27.0	56.2	13.0
	80	47.7	45.1	52.6	38.4	60.0	26.6	43.5	42.3	48.2	36.0	55.3	24.6
	85	49.5	49.5	53.3	46.1	59.5	36.9	45.5	45.5	49.0	43.6	54.9	34.8
	90	51.9	51.9	54.5	52.3	59.4	45.7	49.8	49.8	50.3	49.6	55.0	43.4
1440	75	49.3	41.6	55.1	31.8	63.4	17.0	44.9	38.8	50.4	29.5	58.4	15.1
	80	50.8	48.4	55.5	41.3	62.6	29.1	46.6	45.6	50.9	38.8	57.7	27.0
	85	52.9	52.9	56.4	49.3	62.3	39.7	48.8	48.8	52.0	46.6	57.6	37.4
	90	57.2	57.2	57.8	55.8	62.5	48.8	53.0	53.0	53.6	53.0	58.0	46.4
1680	75	51.8	44.3	57.4	34.1	65.4	18.9	47.3	41.4	52.6	31.7	60.3	16.9
	80	53.6	51.4	58.0	43.9	64.8	31.3	49.3	48.4	53.3	41.3	59.8	29.1
	85	56.0	56.0	59.1	52.2	64.7	42.1	51.8	51.8	54.6	49.4	59.9	39.8
	90	60.2	60.2	60.8	59.0	65.2	51.5	55.9	55.9	56.5	56.1	60.6	49.1
1920	75	54.0	46.7	59.2	36.1	66.9	20.5	49.4	43.7	54.3	33.6	61.8	18.3
	80	56.0	54.1	60.1	46.2	66.6	33.1	51.6	51.0	55.3	43.5	61.6	30.8
	85	58.6	58.6	61.5	54.7	66.8	44.3	54.3	54.3	56.9	51.9	61.9	41.9
	90	62.8	62.8	63.4	61.8	67.5	54.0	58.4	58.4	59.0	58.8	62.8	51.4
2160	75	55.7	48.7	60.7	37.8	68.1	21.7	51.1	45.7	55.7	35.1	62.9	19.5
	80	58.0	56.5	61.8	48.1	68.0	34.7	53.5	53.3	57.0	45.3	62.9	32.3
	85	60.9	60.9	63.5	57.0	68.5	46.1	56.5	56.5	58.8	54.0	63.5	43.6
	90	65.0	65.0	65.6	64.4	69.5	56.1	61.1	61.1	61.1	61.1	64.7	53.4
2400	75	57.1	50.5	61.8	39.1	68.9	22.7	52.4	47.3	56.7	36.3	63.6	20.3
	80	59.7	58.5	63.2	49.7	69.1	35.9	55.1	55.1	58.3	46.8	63.9	33.4
	85	62.8	62.8	65.1	58.9	69.8	47.7	58.3	58.3	60.3	55.9	64.7	45.0
	90	66.8	66.8	67.5	66.6	71.0	57.9	62.9	62.9	62.9	62.9	66.1	55.1
2640	75	58.2	51.9	62.5	40.1	69.4	23.3	53.3	48.7	57.4	37.3	63.9	20.8
	80	61.0	60.3	64.1	51.1	69.8	36.8	56.3	56.3	59.1	48.1	64.5	34.2
	85	64.3	64.3	66.3	60.5	70.7	48.9	59.8	59.8	61.4	57.4	65.6	46.1
	90	68.3	68.3	69.0	68.5	72.2	59.4	64.3	64.3	64.3	64.3	67.2	56.5
2880	75	58.8	53.0	62.9	40.8	69.4	23.6	53.9	49.7	57.6	37.9	63.9	21.0
	80	61.9	61.7	64.7	52.1	70.1	37.4	57.1	57.1	59.6	49.0	64.7	34.7
	85	65.5	65.5	67.1	61.8	71.3	49.8	60.8	60.8	62.2	58.6	66.0	46.9
	90	70.1	70.1	70.1	70.1	73.0	60.6	65.3	65.3	65.3	65.3	67.9	57.6

**Notes:**

1. All capacities shown are gross and have not considered indoor fan heat. To obtain NET cooling capacity subtract indoor fan heat. For indoor fan heat formula, refer to appropriate airflow table notes.
2. MBh = Total gross capacity
3. SHC = Sensible heat capacity
4. Unit applications below 320 cfm/ton are only applicable on THC models without electric heat. Electric and gas heat applications are restricted to applications 320 cfm/ton and above.



# Gross Cooling Capacities

**Table 30. Gross cooling capacities 6 tons high efficiency — three phase T/YHC072E3,4,W**

CFM	Ent DB (°F)	Ambient Temperature (°F)						Ambient Temperature (°F)						Ambient Temperature (°F)					
		85						95						105					
		Entering Wet Bulb Temp (°F)						Entering Wet Bulb Temp (°F)						Entering Wet Bulb Temp (°F)					
		61		67		73		61		67		73		61		67		73	
MBh	SHC	MBh	SHC	MBh	SHC	MBh	SHC	MBh	SHC	MBh	SHC	MBh	SHC	MBh	SHC	MBh	SHC		
1200	75	62.5	48.5	69.3	36.5	78.5	19.0	59.7	47.2	66.1	35.7	74.8	18.6	56.6	45.7	62.6	34.7	71.0	18.0
	80	63.6	55.8	69.3	46.8	77.3	32.3	60.9	54.3	66.1	45.8	73.8	31.6	57.9	52.6	62.7	44.5	70.0	30.8
	85	65.4	61.5	70.0	55.5	76.9	43.9	62.7	59.7	66.9	54.2	73.4	43.0	59.8	57.7	63.5	52.6	69.7	41.9
	90	67.9	65.5	71.3	62.5	77.1	53.9	65.3	63.5	68.3	60.9	73.7	52.7	62.4	61.3	65.0	59.1	70.0	51.4
1440	75	64.9	51.2	71.3	38.6	80.1	20.4	61.9	49.7	67.9	37.6	76.3	19.9	58.7	48.0	64.3	36.4	72.3	19.1
	80	66.5	59.0	71.7	49.4	79.4	34.2	63.5	57.3	68.4	48.1	75.6	33.4	60.3	55.3	64.8	46.7	71.7	32.3
	85	68.7	65.2	72.8	58.6	79.3	46.4	65.8	63.2	69.5	57.1	75.6	45.3	62.7	61.0	66.0	55.3	71.7	44.0
	90	71.5	69.8	74.5	66.1	79.9	56.9	68.7	67.5	71.3	64.3	76.3	55.5	65.7	65.1	67.9	62.3	72.5	53.9
1680	75	66.9	53.4	72.9	40.2	81.3	21.4	63.7	51.7	69.3	39.0	77.3	20.6	60.3	49.8	65.5	37.5	73.0	19.6
	80	68.8	61.7	73.7	51.5	80.9	35.7	65.7	59.8	70.1	50.0	77.0	34.7	62.3	57.6	66.4	48.3	72.8	33.4
	85	71.4	68.5	75.1	61.2	81.2	48.4	68.3	66.3	71.7	59.5	77.4	47.1	65.0	63.9	68.0	57.5	73.3	45.6
	90	74.6	73.5	77.3	69.3	82.2	59.4	71.7	71.1	73.9	67.3	78.5	57.8	68.4	68.4	70.3	65.0	74.4	56.0
1920	75	68.3	55.1	73.9	41.3	81.9	21.9	64.9	53.2	70.2	39.9	77.7	20.9	61.3	51.1	66.2	38.2	73.3	19.7
	80	70.6	64.0	75.1	53.2	81.9	36.7	67.3	61.8	71.4	51.5	77.8	35.5	63.8	59.5	67.5	49.6	73.5	34.0
	85	73.6	71.2	76.9	63.4	82.7	49.9	70.4	68.8	73.3	61.4	78.6	48.4	66.9	66.2	69.4	59.2	74.4	46.7
	90	77.2	76.8	79.5	71.9	84.0	61.4	74.1	74.1	75.9	69.7	80.1	59.6	70.7	70.7	72.1	67.3	75.9	57.7
2160	75	69.2	56.4	74.4	41.9	82.0	21.9	65.7	54.2	70.5	40.3	77.7	20.7	61.9	51.9	66.3	38.4	73.1	19.3
	80	71.9	65.7	76.0	54.3	82.5	37.3	68.5	63.4	72.1	52.4	78.2	35.8	64.7	60.8	68.0	50.3	73.7	34.1
	85	75.3	73.5	78.2	65.0	83.6	50.9	71.9	70.9	74.4	62.9	79.4	49.2	68.2	68.1	70.4	60.5	74.9	47.3
	90	79.3	79.3	81.2	74.1	85.4	63.0	76.0	76.0	77.4	71.7	81.2	61.0	72.4	72.4	73.5	69.0	76.8	58.8
2400	75	69.7	57.1	74.5	42.1	81.7	21.5	65.9	54.8	70.4	40.2	77.1	20.0	62.0	52.3	66.0	38.2	72.4	18.4
	80	72.7	67.0	76.4	55.0	82.5	37.3	69.1	64.5	72.4	52.9	78.0	35.6	65.2	61.7	68.1	50.5	73.3	33.7
	85	76.5	75.3	79.1	66.2	84.0	51.5	72.9	72.5	75.1	63.8	79.6	49.6	69.1	69.1	70.9	61.2	75.0	47.4
	90	80.9	80.9	82.4	75.8	86.2	64.1	77.4	77.4	78.4	73.2	81.8	61.9	73.7	73.7	74.3	70.3	77.3	59.5
2640	75	69.6	57.4	74.0	41.8	80.8	20.5	65.7	54.9	69.7	39.7	76.1	18.9	61.5	52.2	65.2	37.4	71.1	17.0
	80	73.0	67.8	76.3	55.2	82.0	36.9	69.2	65.1	72.1	52.8	77.4	35.0	65.2	62.1	67.6	50.3	72.5	32.9
	85	77.2	76.6	79.4	66.9	83.9	51.6	73.4	73.4	75.2	64.3	79.3	49.4	69.4	69.4	70.8	61.5	74.5	47.1
	90	82.0	82.0	83.0	77.0	86.4	64.7	78.3	78.3	79.0	74.2	82.0	62.2	74.4	74.4	74.6	71.1	77.2	59.6
2880	75	69.0	57.2	73.0	41.0	79.4	19.1	64.9	54.5	68.5	38.7	74.5	17.2	60.6	51.6	63.8	36.2	69.4	15.2
	80	72.8	68.2	75.7	54.9	81.0	36.0	68.8	65.2	71.3	52.3	76.2	33.9	64.6	62.0	66.7	49.6	71.2	31.6
	85	77.4	77.4	79.1	67.1	83.3	51.2	73.4	73.4	74.8	64.3	78.5	48.8	69.3	69.3	70.2	61.3	73.6	46.3
	90	82.6	82.6	83.2	77.7	86.2	64.8	78.7	78.7	79.0	74.7	81.6	62.2	74.6	74.6	74.5	71.4	76.7	59.3

**Notes:**

1. All capacities shown are gross and have not considered indoor fan heat. To obtain NET cooling capacity subtract indoor fan heat. For indoor fan heat formula, refer to appropriate airflow table notes.
2. MBh = Total gross capacity
3. SHC = Sensible heat capacity
4. Unit applications below 320 cfm/ton are only applicable on THC models without electric heat. Electric and gas heat applications are restricted to applications 320 cfm/ton and above.

*Note: Table continues on next page*

**Table 31. Gross cooling capacities 6 tons high efficiency — three phase T/YHC072E3,4,W (continued)**

CFM	Ent DB (°F)	Ambient Temperature (°F)						Ambient Temperature (°F)					
		115						125					
		Entering Wet Bulb Temp (°F)						Entering Wet Bulb Temp (°F)					
		61		67		73		61		67		73	
		MBh	SHC	MBh	SHC	MBh	SHC	MBh	SHC	MBh	SHC	MBh	SHC
1200	75	53.3	44.1	58.9	33.5	66.9	17.3	49.7	42.2	54.9	32.0	62.5	16.3
	80	54.6	50.6	59.1	43.0	65.9	29.8	51.1	48.5	55.2	41.3	61.7	28.5
	85	56.6	55.5	60.0	50.9	65.7	40.6	53.2	53.2	56.2	48.9	61.5	39.1
	90	59.3	58.8	61.5	57.1	66.1	49.8	56.0	56.0	57.8	54.9	62.0	48.1
1440	75	55.2	46.1	60.4	34.9	68.0	18.1	51.5	44.0	56.3	33.3	63.4	16.9
	80	56.9	53.2	61.0	45.0	67.4	31.1	53.3	50.9	56.9	43.1	63.0	29.6
	85	59.3	58.6	62.3	53.4	67.6	42.5	55.7	55.7	58.3	51.2	63.2	40.8
	90	62.4	62.4	64.2	60.1	68.4	52.2	58.9	58.9	60.3	57.7	64.1	50.2
1680	75	56.6	47.7	61.4	35.9	68.6	18.4	52.7	45.4	57.1	34.0	63.9	17.0
	80	58.7	55.3	62.4	46.4	68.4	32.0	54.9	52.7	58.2	44.3	63.8	30.3
	85	61.5	61.2	64.1	55.4	69.0	43.8	57.8	57.8	59.9	53.0	64.4	41.9
	90	65.0	65.0	66.4	62.6	70.2	54.1	61.3	61.3	62.3	60.0	65.7	51.9
1920	75	57.5	48.8	61.9	36.4	68.7	18.3	53.4	46.3	57.4	34.3	63.8	16.7
	80	60.0	56.9	63.3	47.4	68.9	32.3	56.0	54.2	58.9	45.1	64.1	30.5
	85	63.2	63.2	65.3	56.9	69.9	44.7	59.3	59.3	61.0	54.3	65.1	42.6
	90	67.1	67.1	68.1	64.6	71.5	55.5	63.2	63.2	63.8	61.8	66.8	53.1
2160	75	57.9	49.4	61.9	36.4	68.3	17.7	53.6	46.7	57.3	34.1	63.2	15.9
	80	60.8	58.1	63.7	48.0	68.9	32.2	56.6	55.1	59.1	45.4	63.9	30.2
	85	64.4	64.4	66.1	57.9	70.2	45.1	60.3	60.3	61.6	55.1	65.3	42.8
	90	68.6	68.6	69.2	66.2	72.2	56.4	64.2	64.2	64.8	63.2	67.4	53.8
2400	75	57.8	49.6	61.4	35.9	67.4	16.6	53.3	46.6	56.6	33.4	62.1	14.5
	80	61.1	58.7	63.6	48.0	68.4	31.6	56.7	55.5	58.8	45.3	63.3	29.4
	85	65.0	65.0	66.4	58.4	70.1	45.1	60.7	60.7	61.7	55.5	65.0	42.5
	90	69.7	69.7	69.9	67.3	72.5	56.9	64.6	64.6	65.3	64.0	67.5	54.1
2640	75	57.2	49.2	60.4	34.9	66.0	15.0	52.6	46.1	55.4	32.2	60.6	12.8
	80	60.8	58.9	62.9	47.5	67.4	30.6	56.3	55.5	58.0	44.6	62.1	28.1
	85	65.2	65.2	66.2	58.5	69.5	44.5	60.7	60.7	61.3	55.3	64.2	41.8
	90	70.2	70.2	70.1	67.8	72.3	56.8	64.6	64.6	65.3	64.4	67.1	53.8
2880	75	56.0	48.4	58.9	33.5	64.1	12.9	51.3	45.1	53.7	30.6	58.5	10.5
	80	60.1	58.6	61.8	46.6	65.9	29.0	55.4	55.0	56.7	43.5	60.4	26.3
	85	64.9	64.9	65.4	58.1	68.4	43.5	60.2	60.2	60.4	54.7	62.9	40.5
	90	69.0	69.0	69.7	68.0	71.5	56.3	64.1	64.1	64.8	64.3	66.2	53.1

**Notes:**

1. All capacities shown are gross and have not considered indoor fan heat. To obtain NET cooling capacity subtract indoor fan heat. For indoor fan heat formula, refer to appropriate airflow table notes.
2. MBh = Total gross capacity
3. SHC = Sensible heat capacity
4. Unit applications below 320 cfm/ton are only applicable on THC models without electric heat. Electric and gas heat applications are restricted to applications 320 cfm/ton and above.



# Gross Cooling Capacities

**Table 32. Gross cooling capacities 6 tons high efficiency — three phase T/YHC074F3,4**

CFM	Ent DB (°F)	Ambient Temperature (°F)						Ambient Temperature (°F)						Ambient Temperature (°F)					
		85						95						105					
		Entering Wet Bulb Temp (°F)						Entering Wet Bulb Temp (°F)						Entering Wet Bulb Temp (°F)					
		61		67		73		61		67		73		61		67		73	
MBh	SHC	MBh	SHC	MBh	SHC	MBh	SHC	MBh	SHC	MBh	SHC	MBh	SHC	MBh	SHC	MBh	SHC		
1200	75	58.7	43.3	68.2	35.5	76.0	27.1	56.9	41.2	64.2	33.4	71.6	25.0	53.1	39.0	60.0	31.2	67.1	22.9
	80	58.7	50.0	68.3	42.3	76.1	33.9	57.0	47.8	64.4	40.2	71.7	31.8	53.2	45.6	60.2	38.0	67.2	29.7
	85	60.4	56.0	68.4	48.9	76.2	40.7	57.1	53.6	64.5	46.8	71.9	38.6	53.6	51.2	60.4	44.6	67.4	36.5
	90	61.8	61.8	68.5	55.7	76.3	47.5	59.0	59.0	64.6	53.5	72.0	45.4	55.9	55.9	60.4	51.3	67.5	43.3
1440	75	63.9	47.8	71.5	38.2	79.0	27.9	60.0	45.6	67.3	36.0	74.3	25.8	55.8	43.3	62.8	33.8	69.4	23.6
	80	64.0	55.8	71.7	46.4	79.1	36.1	60.1	53.6	67.4	44.2	74.5	34.0	55.9	50.9	63.0	41.9	69.6	31.8
	85	64.7	62.2	71.9	54.3	79.2	44.2	61.1	59.7	67.6	52.1	74.6	42.1	57.4	57.4	63.1	49.8	69.7	39.9
	90	67.5	67.5	72.0	62.4	79.4	52.7	64.3	64.3	67.7	60.0	74.8	50.2	60.8	60.8	63.2	57.4	69.9	48.0
1680	75	66.4	52.0	74.0	40.7	81.1	28.6	62.2	49.8	69.4	38.5	76.1	26.4	57.9	47.4	64.8	36.2	70.9	24.2
	80	66.4	60.8	74.2	50.2	81.2	38.1	62.5	58.2	69.6	48.0	76.4	35.7	58.4	55.4	65.0	45.7	71.1	33.7
	85	68.3	68.3	74.3	59.3	81.4	47.5	64.9	64.9	69.8	57.1	76.4	45.3	61.2	61.2	65.2	54.8	71.2	43.1
	90	72.1	72.1	74.5	67.9	81.5	57.1	68.6	68.6	70.2	65.2	76.6	54.9	64.8	64.8	65.9	62.4	71.4	52.6
1920	75	68.4	56.1	75.8	43.1	82.6	29.2	64.0	53.8	71.1	40.8	77.4	27.0	59.5	51.4	66.2	38.5	72.0	24.8
	80	69.0	65.1	76.0	53.9	82.8	40.1	64.9	62.5	71.3	51.6	77.6	37.8	60.7	59.8	66.4	49.3	72.1	35.6
	85	72.0	72.0	76.1	64.2	82.9	50.8	68.3	68.3	71.5	61.9	77.7	48.6	64.3	64.3	66.6	59.6	72.3	46.3
	90	75.8	75.8	76.4	73.9	83.1	61.7	72.0	72.0	72.4	70.4	77.9	59.4	67.9	67.9	68.0	66.4	72.5	57.1
2160	75	69.9	60.1	77.1	45.3	83.7	29.8	65.5	57.7	72.3	43.1	78.4	27.6	60.6	54.9	67.3	40.8	72.3	27.2
	80	71.2	69.4	77.4	57.4	83.9	42.0	67.1	67.1	72.6	55.2	78.6	39.7	63.1	63.1	67.6	52.8	72.9	37.4
	85	74.9	74.9	77.5	69.0	84.1	54.0	71.0	71.0	72.7	66.6	78.7	51.7	66.9	66.9	67.7	64.0	73.1	49.4
	90	78.8	78.8	78.9	76.5	84.4	66.2	74.7	74.7	74.8	72.5	79.0	63.9	70.3	70.3	70.4	68.2	73.4	61.5
2400	75	71.0	63.6	78.2	47.5	84.7	30.4	66.6	60.8	73.3	45.2	79.2	28.1	62.0	57.8	68.2	42.9	72.9	28.5
	80	73.3	73.3	78.5	61.0	84.9	43.9	69.3	69.3	73.6	58.7	79.4	41.6	65.1	65.1	68.4	56.2	73.6	39.3
	85	77.4	77.4	78.6	73.5	85.2	57.1	73.2	73.2	73.7	70.4	79.6	54.8	68.8	68.8	69.2	67.1	73.8	52.4
	90	81.3	81.3	81.4	77.1	85.5	70.7	76.9	76.9	77.0	72.9	79.9	68.4	72.1	72.1	72.2	68.4	74.0	65.5
2640	75	72.4	66.5	79.1	49.6	85.5	30.9	67.9	63.6	74.1	47.3	79.9	28.7	63.2	60.7	68.8	44.9	73.9	29.8
	80	75.4	75.4	79.4	64.4	85.8	45.7	71.2	71.2	74.4	62.0	80.1	43.5	66.8	66.8	69.2	59.6	74.2	41.1
	85	79.4	79.4	79.5	76.6	86.0	60.2	75.1	75.1	75.2	73.5	80.3	57.9	70.4	70.4	70.5	69.1	74.4	55.5
	90	83.3	83.3	83.4	78.5	86.1	75.1	78.7	78.7	78.8	74.1	80.7	71.9	73.7	73.7	73.7	69.3	75.0	68.7
2880	75	73.6	69.3	79.8	51.7	86.2	31.5	69.0	66.5	74.7	49.4	80.5	29.3	64.3	64.3	69.4	47.0	74.4	31.1
	80	77.1	77.1	79.9	68.4	86.5	47.6	72.8	72.8	75.1	65.4	80.7	45.3	68.3	68.3	69.6	62.4	74.7	42.8
	85	81.2	81.2	81.3	79.5	86.7	63.3	76.6	76.6	76.7	75.0	80.9	60.9	71.7	71.7	71.8	69.6	74.8	58.4
	90	85.2	85.2	85.3	81.7	87.2	78.2	80.3	80.3	80.4	77.0	81.6	75.1	75.0	75.0	75.1	72.0	75.7	71.8

**Notes:**

1. All capacities shown are gross and have not considered indoor fan heat. To obtain NET cooling capacity subtract indoor fan heat. For indoor fan heat formula, refer to appropriate airflow table notes.
2. MBh = Total gross capacity
3. SHC = Sensible heat capacity
4. Unit applications below 320 cfm/ton are only applicable on THC models without electric heat. Electric and gas heat applications are restricted to applications 320 cfm/ton and above.

*Note: Table continues on next page*

Table 33. Gross cooling capacities 6 tons high efficiency — three phase T/YHC074F3,4 (continued)

CFM	Ent DB (°F)	Ambient Temperature (°F)						Ambient Temperature (°F)					
		115						125					
		Entering Wet Bulb Temp (°F)						Entering Wet Bulb Temp (°F)					
		61		67		73		61		67		73	
		MBh	SHC	MBh	SHC	MBh	SHC	MBh	SHC	MBh	SHC	MBh	SHC
1200	75	49.0	36.7	55.7	29.0	62.3	20.5	44.7	34.4	50.9	26.6	56.7	18.2
	80	49.2	43.4	55.8	35.7	62.3	27.5	45.9	40.7	51.1	33.4	56.9	25.1
	85	49.8	48.2	56.0	42.4	62.4	34.2	46.1	46.1	51.3	40.0	57.1	31.8
	90	52.6	52.6	56.2	49.2	62.6	41.0	49.1	49.1	52.8	46.4	57.2	38.7
1440	75	51.4	40.9	58.0	31.5	64.1	21.3	46.9	38.5	52.9	29.1	58.2	18.8
	80	51.7	48.2	58.3	39.7	64.2	29.5	47.4	45.3	53.2	37.2	58.4	27.0
	85	53.9	53.9	58.5	47.5	64.4	37.5	50.1	50.1	53.4	45.1	58.5	35.1
	90	57.2	57.2	58.8	54.6	64.5	45.7	53.2	53.2	54.1	51.6	58.7	43.2
1680	75	53.3	45.0	59.8	33.9	65.3	21.9	48.6	42.5	54.4	31.4	59.2	19.4
	80	54.2	52.6	60.0	43.3	65.4	31.3	49.8	49.8	54.6	40.8	59.3	28.8
	85	57.4	57.4	60.2	52.4	65.6	40.7	53.2	53.2	54.8	49.8	59.4	38.2
	90	60.8	60.8	61.2	59.6	65.7	50.2	56.3	56.3	56.4	55.2	59.6	47.6
1920	75	54.8	48.9	61.0	36.1	66.2	22.4	49.8	45.8	55.4	33.6	59.9	19.9
	80	56.6	56.6	61.3	46.9	66.4	33.2	52.2	52.2	55.7	44.3	59.9	30.7
	85	60.2	60.2	61.4	57.1	66.4	43.8	55.5	55.5	55.8	53.9	60.1	41.3
	90	63.4	63.4	63.5	62.0	66.6	54.7	58.4	58.4	58.4	57.1	60.2	52.0
2160	75	56.0	51.9	61.9	38.3	66.9	22.9	51.0	48.1	56.2	35.7	60.3	21.0
	80	58.8	58.8	62.2	50.3	67.0	35.0	54.2	54.2	56.5	47.7	60.5	32.5
	85	62.3	62.3	63.1	60.6	67.1	46.9	57.3	57.3	58.0	56.5	60.6	44.3
	90	65.4	65.4	65.5	63.5	67.2	59.0	59.8	59.8	59.9	58.1	60.9	55.4
2400	75	57.1	54.1	62.7	40.4	67.0	24.9	52.2	52.2	56.8	37.8	61.1	21.1
	80	60.6	60.6	63.0	53.7	67.5	36.9	55.7	55.7	57.0	50.8	61.2	34.2
	85	64.0	64.0	64.4	63.0	67.7	50.0	58.6	58.6	58.9	57.1	61.3	47.2
	90	66.9	66.9	67.0	64.9	68.1	62.1	61.0	61.0	61.1	61.1	61.5	58.5
2640	75	58.3	58.3	63.2	42.4	67.7	25.7	53.5	53.5	57.2	39.7	61.4	21.2
	80	62.1	62.1	63.5	56.7	68.0	38.6	56.9	56.9	57.6	53.2	61.6	36.0
	85	65.3	65.3	65.4	63.5	68.1	52.9	59.5	59.5	59.6	57.4	61.7	50.1
	90	68.2	68.2	68.3	65.9	68.8	65.3	61.9	61.9	62.0	62.0	62.0	59.3
2880	75	59.6	59.6	63.7	44.4	68.3	26.9	54.6	54.6	57.6	41.6	61.7	22.1
	80	63.3	63.3	64.1	59.0	68.4	40.3	57.8	57.8	58.1	55.5	61.9	37.7
	85	66.3	66.3	66.3	63.9	68.4	55.8	60.4	60.4	60.4	57.7	62.3	53.0
	90	69.2	69.2	69.3	66.4	69.3	66.3	62.5	62.5	62.6	62.6	62.6	59.9

Notes:

1. All capacities shown are gross and have not considered indoor fan heat. To obtain NET cooling capacity subtract indoor fan heat. For indoor fan heat formula, refer to appropriate airflow table notes.
2. MBh = Total gross capacity
3. SHC = Sensible heat capacity
4. Unit applications below 320 cfm/ton are only applicable on THC models without electric heat. Electric and gas heat applications are restricted to applications 320 cfm/ton and above.



# Gross Cooling Capacities

**Table 34. Gross cooling capacities 7.5 tons high efficiency – three phase T/YHC092F3,4,W**

CFM	Ent DB (°F)	Ambient Temperature (°F)						Ambient Temperature (°F)						Ambient Temperature (°F)					
		85						95						105					
		Entering Wet Bulb Temp (°F)						Entering Wet Bulb Temp (°F)						Entering Wet Bulb Temp (°F)					
		61		67		73		61		67		73		61		67		73	
MBh	SHC	MBh	SHC	MBh	SHC	MBh	SHC	MBh	SHC	MBh	SHC	MBh	SHC	MBh	SHC	MBh	SHC		
1500	75	73.3	55.9	82.4	43.1	94.8	24.4	69.0	53.3	77.7	40.9	89.7	22.7	64.4	50.6	72.8	38.6	84.4	20.9
	80	74.0	64.4	81.6	54.6	92.4	39.1	69.8	61.6	77.1	52.3	87.5	37.1	65.4	58.6	72.3	49.7	82.3	35.0
	85	75.5	71.1	81.6	64.4	90.9	52.0	71.5	68.0	77.2	61.8	86.1	49.8	67.2	64.8	72.5	59.0	81.0	47.4
	90	77.7	76.0	82.3	72.4	90.1	63.1	73.8	72.6	78.0	69.5	85.4	60.6	69.7	69.2	73.5	66.5	80.5	58.0
1800	75	77.3	60.2	86.1	46.9	98.1	27.8	72.8	57.5	81.3	44.6	92.9	25.9	68.1	54.7	76.2	42.2	87.4	23.9
	80	78.3	69.1	85.6	58.9	96.1	42.9	74.0	66.1	80.9	56.3	91.0	40.7	69.5	63.0	76.0	53.6	85.7	38.4
	85	80.1	76.2	85.9	69.1	94.9	56.1	76.0	73.0	81.3	66.3	89.9	53.8	71.5	69.6	76.5	63.3	84.7	51.2
	90	82.7	81.5	86.9	77.5	94.4	67.6	78.7	78.0	82.5	74.4	89.6	65.0	74.4	74.4	77.9	71.2	84.5	62.2
2100	75	80.8	64.2	89.3	50.4	101.0	30.7	76.3	61.3	84.4	47.9	95.7	28.7	71.4	58.3	79.1	45.3	90.1	26.5
	80	82.2	73.5	89.2	62.7	99.3	46.2	77.8	70.3	84.4	60.0	94.1	43.9	73.1	67.1	79.3	57.2	88.6	41.5
	85	84.4	80.9	89.8	73.3	98.4	59.9	80.0	77.6	85.1	70.4	93.3	57.3	75.5	74.0	80.1	67.3	88.0	54.6
	90	87.2	86.6	91.1	82.1	98.3	71.8	83.1	83.0	86.6	78.9	93.3	69.0	78.6	78.6	81.8	75.5	88.1	66.0
2400	75	84.0	67.7	92.2	53.4	103.5	33.3	79.3	64.7	87.0	50.8	98.0	31.1	74.3	61.5	81.7	48.0	92.2	28.7
	80	85.7	77.4	92.3	66.2	102.1	49.1	81.1	74.1	87.3	63.3	96.8	46.7	76.2	70.7	82.1	60.3	91.1	44.1
	85	88.1	85.3	93.2	77.1	101.5	63.2	83.7	81.7	88.4	74.0	96.3	60.5	79.0	78.1	83.3	70.8	90.8	57.7
	90	91.4	91.4	94.9	86.3	101.7	75.5	87.0	87.0	90.2	83.0	96.6	72.5	82.5	82.5	85.3	79.4	91.3	69.4
2700	75	86.7	70.8	94.5	56.0	105.5	35.4	81.8	67.7	89.3	53.3	99.9	33.0	76.7	64.3	83.7	50.4	94.0	30.6
	80	88.7	80.9	95.0	69.2	104.5	51.6	84.0	77.5	89.9	66.2	99.0	49.0	79.0	73.9	84.5	63.0	93.2	46.3
	85	91.5	89.2	96.3	80.6	104.2	66.1	86.9	85.5	91.3	77.3	98.9	63.3	82.0	81.7	86.0	73.9	93.2	60.3
	90	95.0	95.0	98.3	90.1	104.7	78.8	90.6	90.6	93.4	86.6	99.5	75.7	85.8	85.8	88.3	83.0	94.0	72.4
3000	75	89.0	73.6	96.5	58.2	107.2	37.1	83.9	70.2	91.1	55.3	101.4	34.6	78.7	66.7	85.4	52.3	95.3	32.0
	80	91.3	84.0	97.3	71.8	106.4	53.7	86.4	80.4	92.0	68.6	100.8	51.0	81.3	76.7	86.5	65.3	94.9	48.1
	85	94.4	92.7	98.8	83.6	106.5	68.6	89.7	88.9	93.7	80.1	101.0	65.6	84.7	84.7	88.3	76.6	95.2	62.5
	90	98.3	98.3	101.2	93.6	107.3	81.7	93.7	93.7	96.2	89.9	101.9	78.4	88.8	88.8	90.9	86.0	96.2	75.0
3300	75	90.8	75.9	98.0	60.0	108.3	38.4	85.6	72.4	92.4	57.0	102.4	35.7	80.2	68.7	86.6	53.8	96.2	33.0
	80	93.5	86.7	99.1	74.0	107.9	55.4	88.4	83.0	93.7	70.7	102.1	52.5	83.1	79.1	88.0	67.2	96.1	49.5
	85	96.9	95.8	101.0	86.2	108.3	70.7	92.0	91.8	95.7	82.6	102.6	67.6	86.8	86.8	90.2	78.9	96.7	64.2
	90	101.1	101.1	103.6	96.5	109.4	84.2	96.3	96.3	98.5	92.7	103.9	80.8	91.3	91.3	93.1	88.7	98.1	77.2
3600	75	92.2	77.8	99.0	61.4	109.1	39.3	86.9	74.1	93.3	58.2	103.0	36.5	81.3	70.3	87.4	54.8	96.6	33.5
	80	95.2	89.0	100.5	75.8	109.0	56.7	90.0	85.1	94.9	72.3	103.0	53.7	84.6	81.1	89.1	68.7	96.8	50.5
	85	98.9	98.5	102.7	88.4	109.7	72.4	93.9	93.9	97.3	84.6	103.9	69.1	88.6	88.6	91.6	80.7	97.8	65.6
	90	103.4	103.4	105.7	99.1	111.1	86.3	98.5	98.5	100.4	95.1	105.4	82.7	93.4	93.4	94.8	91.0	99.5	79.0

**Notes:**

1. All capacities shown are gross and have not considered indoor fan heat. To obtain NET cooling capacity subtract indoor fan heat. For indoor fan heat formula, refer to appropriate airflow table notes.
2. MBh = Total gross capacity
3. SHC = Sensible heat capacity
4. Unit applications below 320 cfm/ton are only applicable on THC models without electric heat. Electric and gas heat applications are restricted to applications 320 cfm/ton and above.

*Note: Table continues on next page*



**Table 35. Gross cooling capacities 7.5 tons high efficiency – three phase T/YHC092F3,4,W (continued)**

CFM	Ent DB (°F)	Ambient Temperature (°F)						Ambient Temperature (°F)					
		115						125					
		Entering Wet Bulb Temp (°F)						Entering Wet Bulb Temp (°F)					
		61		67		73		61		67		73	
		MBh	SHC	MBh	SHC	MBh	SHC	MBh	SHC	MBh	SHC	MBh	SHC
1500	75	59.6	47.7	67.6	36.2	78.8	18.8	54.5	44.7	62.1	33.6	72.9	16.7
	80	60.7	55.5	67.2	47.0	76.9	32.7	55.8	52.2	61.9	44.2	71.1	30.3
	85	62.6	61.4	67.6	56.0	75.7	44.9	57.8	57.8	62.4	52.9	70.1	42.2
	90	65.3	65.3	68.7	63.3	75.3	55.2	60.6	60.6	63.7	59.9	69.9	52.2
1800	75	63.2	51.6	70.8	39.6	81.7	21.7	57.9	48.5	65.2	36.8	75.7	19.4
	80	64.6	59.8	70.8	50.8	80.1	36.0	59.5	56.3	65.3	47.8	74.2	33.4
	85	66.9	66.1	71.5	60.2	79.3	48.5	61.9	61.9	66.1	57.0	73.5	45.7
	90	69.8	69.8	72.9	67.8	79.2	59.3	65.0	65.0	67.7	64.3	73.6	56.2
2100	75	66.3	55.1	73.6	42.6	84.2	24.2	60.9	51.8	67.9	39.7	78.0	21.7
	80	68.1	63.6	73.9	54.2	82.9	38.9	62.9	60.0	68.3	51.0	76.9	36.1
	85	70.6	70.3	74.9	64.0	82.4	51.8	65.6	65.6	69.4	60.6	76.5	48.8
	90	74.0	74.0	76.7	72.0	82.6	62.9	69.0	69.0	71.4	68.3	76.9	59.7
2400	75	69.0	58.2	76.0	45.1	86.2	26.3	63.5	54.7	70.1	42.1	79.9	23.6
	80	71.1	67.1	76.6	57.1	85.3	41.4	65.7	63.4	70.8	53.8	79.1	38.5
	85	74.0	74.0	77.9	67.3	85.1	54.7	68.8	68.8	72.3	63.8	79.0	51.5
	90	77.6	77.6	80.0	75.8	85.6	66.2	72.5	72.5	74.5	71.9	79.8	62.8
2700	75	71.3	60.9	77.9	47.3	87.8	27.9	65.6	57.2	71.9	44.1	81.4	25.1
	80	73.7	70.2	78.9	59.7	87.2	43.4	68.2	66.3	72.9	56.2	80.9	40.4
	85	76.9	76.9	80.5	70.3	87.3	57.1	71.5	71.5	74.7	66.6	81.2	53.8
	90	80.9	80.9	82.9	79.1	88.2	69.0	75.6	75.6	77.3	75.1	82.2	65.5
3000	75	73.1	63.1	79.4	49.0	89.0	29.2	67.3	59.3	73.3	45.7	82.4	26.2
	80	75.9	72.8	80.7	61.8	88.7	45.1	70.2	68.8	74.6	58.2	82.2	41.8
	85	79.4	79.4	82.7	72.8	89.1	59.2	73.9	73.9	76.7	69.0	82.8	55.7
	90	83.7	83.7	85.4	82.1	90.3	71.5	78.8	78.8	79.6	77.9	84.2	67.7
3300	75	74.5	64.9	80.5	50.4	89.7	30.0	68.6	61.0	74.2	46.9	83.0	26.9
	80	77.6	75.0	82.1	63.6	89.7	46.3	71.8	70.8	75.9	59.8	83.1	42.9
	85	81.4	81.4	84.4	75.0	90.5	60.8	75.8	75.8	78.3	70.9	84.1	57.2
	90	86.0	86.0	87.4	84.6	92.0	73.5	80.7	80.7	81.5	80.3	85.7	69.6
3600	75	75.5	66.4	81.1	51.3	90.0	30.4	69.4	62.3	74.7	47.6	83.1	27.2
	80	78.9	76.9	83.0	64.9	90.3	47.1	72.9	72.5	76.7	61.0	83.6	43.6
	85	83.0	83.0	85.6	76.7	91.4	62.0	77.2	77.2	79.4	72.5	84.8	58.2
	90	88.0	88.0	89.0	86.7	93.3	75.1	82.1	82.1	83.0	82.3	86.8	71.1

**Notes:**

1. All capacities shown are gross and have not considered indoor fan heat. To obtain NET cooling capacity subtract indoor fan heat. For indoor fan heat formula, refer to appropriate airflow table notes.
2. MBh = Total gross capacity
3. SHC = Sensible heat capacity
4. Unit applications below 320 cfm/ton are only applicable on THC models without electric heat. Electric and gas heat applications are restricted to applications 320 cfm/ton and above.



# Gross Cooling Capacities

**Table 36. Gross cooling capacities 8.5 tons high efficiency – three phase T/YHC102F3,4,W**

CFM	Ent DB (°F)	Ambient Temperature (°F)						Ambient Temperature (°F)											
		85						95						105					
		Entering Wet Bulb Temp (°F)						Entering Wet Bulb Temp (°F)						Entering Wet Bulb Temp (°F)					
		61		67		73		61		67		73		61		67		73	
MBh	SHC	MBh	SHC	MBh	SHC	MBh	SHC	MBh	SHC	MBh	SHC	MBh	SHC	MBh	SHC	MBh	SHC		
1700	75	84.4	64.2	93.7	45.5	106.8	18.8	80.3	62.2	89.2	44.2	101.9	31.4	75.7	59.8	84.2	42.6	96.6	30.3
	80	85.8	74.8	92.9	60.7	103.8	38.6	81.7	72.4	88.4	59.0	98.9	37.5	77.1	69.6	83.5	56.9	93.6	36.2
	85	88.0	82.5	92.9	73.0	101.6	55.4	83.9	79.6	88.4	70.8	96.7	54.0	79.4	76.4	83.5	68.3	91.5	52.2
	90	91.0	87.2	93.7	82.3	100.3	69.4	87.0	83.9	89.3	79.7	95.4	67.5	82.5	80.3	84.4	76.8	90.2	65.2
2040	75	87.3	68.6	96.2	50.1	108.8	23.5	83.1	66.4	91.5	48.6	103.8	35.6	78.4	63.9	86.4	46.8	98.3	34.2
	80	88.9	79.4	95.6	65.4	106.0	43.4	84.7	76.7	90.9	63.5	101.0	42.2	80.1	73.7	85.9	61.2	95.6	40.6
	85	91.4	87.1	95.8	77.8	104.1	60.4	87.2	84.0	91.2	75.4	99.1	58.7	82.6	80.6	86.2	72.7	93.7	56.7
	90	94.7	92.0	96.9	87.2	103.0	74.4	90.5	88.5	92.4	84.4	98.1	72.3	86.0	84.6	87.4	81.3	92.7	69.9
2380	75	89.9	72.7	98.3	54.3	110.5	27.9	85.6	70.3	93.5	52.6	105.3	39.4	80.8	67.6	88.3	50.6	99.7	37.9
	80	91.8	83.5	97.9	69.8	107.9	47.9	87.5	80.7	93.2	67.6	102.8	46.5	82.7	77.5	88.1	65.1	97.3	44.7
	85	94.5	91.4	98.5	82.2	106.2	65.0	90.2	88.1	93.8	79.6	101.2	63.1	85.5	84.5	88.6	76.8	95.6	60.9
	90	98.1	96.3	99.8	91.8	105.4	79.1	93.8	92.6	95.2	88.7	100.4	76.8	89.1	88.6	90.1	85.4	94.9	74.2
2720	75	92.2	76.4	100.1	58.2	111.8	31.9	87.7	73.8	95.2	56.3	106.5	43.0	82.8	70.9	89.9	54.1	100.8	41.3
	80	94.3	87.3	100.0	73.7	109.5	52.0	89.9	84.3	95.2	71.4	104.3	50.4	85.0	80.9	89.9	68.7	98.6	48.5
	85	97.3	95.3	100.8	86.3	108.1	69.2	92.9	91.8	96.0	83.5	102.9	67.1	88.0	88.1	90.7	80.4	97.3	64.8
	90	101.1	100.4	102.4	95.9	107.5	83.4	96.7	96.5	97.6	92.7	102.3	80.9	91.9	92.2	92.4	89.2	96.7	78.1
3060	75	94.2	79.8	101.6	61.7	112.8	47.8	89.6	77.0	96.6	59.6	107.5	46.2	84.6	73.8	91.2	57.2	101.6	44.3
	80	96.6	90.8	101.8	77.3	110.8	55.8	92.0	87.6	96.8	74.8	105.5	54.0	87.0	84.0	91.4	72.0	99.7	51.8
	85	99.8	98.9	102.8	90.0	109.6	73.1	95.3	95.2	97.9	87.0	104.3	70.8	90.3	91.2	92.5	83.8	98.6	68.2
	90	103.9	104.0	104.7	99.7	109.3	87.4	99.3	99.9	99.8	96.3	104.0	84.7	94.4	95.5	94.4	92.6	98.3	81.7
3400	75	95.9	82.8	102.8	64.9	113.6	50.8	91.2	79.8	97.7	62.6	108.0	49.1	86.0	76.4	92.1	60.0	102.1	47.0
	80	98.5	93.9	103.2	80.6	111.8	69.2	93.8	90.5	98.1	77.9	106.3	67.0	88.7	86.7	92.6	74.8	100.4	64.6
	85	102.0	102.1	104.5	93.4	110.9	76.6	97.3	98.2	99.4	90.2	105.4	74.1	92.2	94.0	94.0	86.7	99.5	71.4
	90	106.3	107.3	106.6	103.2	110.8	91.0	101.7	103.0	101.6	99.6	105.4	88.1	96.6	98.4	96.2	95.7	99.5	84.9
3740	75	97.2	85.4	103.7	67.7	114.0	53.6	92.4	82.2	98.4	65.2	108.3	51.7	87.1	78.7	92.8	62.4	102.3	49.4
	80	100.1	96.6	104.4	83.5	112.4	72.1	95.3	93.0	99.2	80.6	106.8	69.8	90.1	89.1	93.5	77.3	100.8	67.1
	85	103.8	104.9	105.9	96.4	111.8	79.7	99.0	100.9	100.7	93.0	106.2	77.1	93.9	96.5	95.1	89.3	100.2	74.1
	90	108.4	110.3	108.3	106.3	111.9	94.3	103.6	105.8	103.1	102.5	106.4	91.2	98.5	101.0	97.6	98.4	100.5	87.8
4080	75	98.3	87.7	104.2	70.1	114.1	56.0	93.3	84.3	98.9	67.4	108.3	53.9	87.9	80.6	93.1	64.4	102.1	51.5
	80	101.4	99.0	105.2	86.0	112.8	74.7	96.5	95.2	99.8	82.9	107.1	72.2	91.1	91.0	94.1	79.5	100.9	69.4
	85	105.4	107.4	106.9	99.0	112.4	82.5	100.5	103.1	101.7	95.4	106.7	79.7	95.2	98.6	95.9	91.6	100.6	76.5
	90	110.2	112.9	109.6	104.7	112.8	97.1	105.3	108.2	104.3	105.0	107.1	93.9	100.0	103.2	98.6	100.7	101.1	90.3

**Notes:**

1. All capacities shown are gross and have not considered indoor fan heat. To obtain NET cooling capacity subtract indoor fan heat. For indoor fan heat formula, refer to appropriate airflow table notes.
2. MBh = Total gross capacity
3. SHC = Sensible heat capacity
4. Unit applications below 320 cfm/ton are only applicable on THC models without electric heat. Electric and gas heat applications are restricted to applications 320 cfm/ton and above.

*Note: Table continues on next page*

**Table 37. Gross cooling capacities 8.5 tons high efficiency – three phase T/YHC102F3,4,W (continued)**

CFM	Ent DB (°F)	Ambient Temperature (°F)						Ambient Temperature (°F)					
		115						125					
		Entering Wet Bulb Temp (°F)						Entering Wet Bulb Temp (°F)					
		61		67		73		61		67		73	
		MBh	SHC	MBh	SHC	MBh	SHC	MBh	SHC	MBh	SHC	MBh	SHC
1700	75	70.8	57.2	78.9	40.6	90.8	16.0	65.4	54.2	73.1	38.3	84.6	14.4
	80	72.2	66.5	78.1	54.5	87.9	34.5	66.9	63.1	72.4	51.8	81.7	32.5
	85	74.5	72.9	78.2	65.5	85.8	50.1	69.2	69.0	72.5	62.4	79.7	47.6
	90	77.7	76.3	79.2	73.5	84.5	62.7	72.4	72.0	73.5	70.0	78.5	59.8
2040	75	73.3	61.0	81.0	44.6	92.4	20.1	67.8	57.8	75.1	42.1	86.1	18.4
	80	75.0	70.4	80.5	58.6	89.7	38.8	69.6	66.8	74.6	55.7	83.5	36.6
	85	77.6	76.9	80.8	69.7	87.9	54.4	72.1	72.9	75.0	66.4	81.7	51.8
	90	81.0	80.5	82.0	77.8	86.9	67.1	75.6	76.0	76.2	74.1	80.7	64.1
2380	75	75.6	64.5	82.7	48.3	93.7	23.9	69.9	61.1	76.7	45.6	87.3	22.0
	80	77.5	74.0	82.5	62.4	91.3	42.7	71.9	70.2	76.5	59.3	84.9	40.3
	85	80.3	80.6	83.1	73.5	89.7	58.4	74.8	76.4	77.2	70.0	83.4	55.6
	90	84.0	84.3	84.6	81.8	89.0	71.2	78.5	79.6	78.7	77.8	82.7	68.0
2720	75	77.5	67.6	84.2	51.5	94.7	27.4	71.8	64.1	78.1	48.7	88.2	25.2
	80	79.7	77.3	84.2	65.8	92.5	46.2	74.0	73.3	78.1	62.5	86.0	43.6
	85	82.8	83.9	85.1	77.0	91.2	62.1	77.1	79.5	79.0	73.3	84.7	59.0
	90	86.7	87.7	86.8	85.4	90.7	75.0	81.1	82.8	80.8	81.2	84.3	71.5
3060	75	79.1	70.4	85.3	54.5	95.4	30.5	73.3	66.6	79.1	51.4	88.7	28.1
	80	81.6	80.1	85.6	68.8	93.5	49.4	75.8	75.9	79.4	65.3	86.8	46.6
	85	84.9	86.9	86.7	80.2	92.4	65.3	79.1	82.3	80.5	76.2	85.8	62.1
	90	89.1	90.8	88.7	88.6	92.2	78.4	83.3	85.7	82.6	84.3	85.6	74.7
3400	75	80.4	72.8	86.2	57.0	95.8	44.7	74.5	68.9	79.8	53.8	89.0	30.7
	80	83.2	82.6	86.7	71.5	94.1	52.2	77.2	78.3	80.4	67.8	87.3	49.2
	85	86.7	89.5	88.1	82.9	93.3	68.3	80.8	84.7	81.8	78.8	86.5	64.9
	90	91.2	93.5	90.3	91.5	93.3	81.4	85.3	88.2	84.0	86.9	86.6	77.6
3740	75	81.4	74.9	86.7	59.2	95.8	46.9	75.3	70.7	80.2	55.8	88.9	32.8
	80	84.4	84.8	87.5	73.8	94.4	64.2	78.3	80.2	81.0	69.9	87.5	51.5
	85	88.2	91.8	89.1	85.3	93.8	70.8	82.2	86.8	82.7	81.0	87.0	67.2
	90	92.9	95.8	91.6	94.0	94.1	84.1	86.9	90.4	85.2	89.2	87.3	80.0
4080	75	82.1	76.6	86.9	61.1	95.5	48.8	75.9	72.2	80.3	57.5	88.5	34.6
	80	85.3	86.6	87.9	75.7	94.4	66.2	79.2	81.8	81.4	71.6	87.4	53.4
	85	89.4	93.7	89.8	87.4	94.0	73.0	83.3	88.5	83.3	82.9	87.1	69.3
	90	94.4	97.8	92.5	96.1	94.6	86.4	88.2	92.2	86.0	91.2	87.7	82.2

**Notes:**

1. All capacities shown are gross and have not considered indoor fan heat. To obtain NET cooling capacity subtract indoor fan heat. For indoor fan heat formula, refer to appropriate airflow table notes.
2. MBh = Total gross capacity
3. SHC = Sensible heat capacity
4. Unit applications below 320 cfm/ton are only applicable on THC models without electric heat. Electric and gas heat applications are restricted to applications 320 cfm/ton and above.



## Gross Cooling Capacities

**Table 38. Gross cooling capacities 10 tons high efficiency – three phase T/YHC120F3,4,W**

CFM	Ent DB (°F)	Ambient Temperature (°F)						Ambient Temperature (°F)			Ambient Temperature (°F)								
		85						95			105								
		Entering Wet Bulb Temp (°F)						Entering Wet Bulb Temp (°F)			Entering Wet Bulb Temp (°F)								
		61		67		73		61		67	73	61		67	73				
		MBh	SHC	MBh	SHC	MBh	SHC	MBh	SHC	MBh	SHC	MBh	SHC	MBh	SHC				
2000	75	95.0	71.7	106.7	55.9	122.3	33.1	90.6	69.2	101.8	53.9	116.9	31.6	86.0	66.6	96.7	51.8	111.2	30.1
	80	96.2	81.9	106.0	70.1	119.6	51.3	91.9	79.0	101.1	67.7	114.2	49.5	87.4	76.0	96.0	65.3	108.6	47.6
	85	98.6	89.7	106.3	82.0	118.0	67.2	94.3	86.4	101.5	79.2	112.7	65.0	89.8	83.1	96.5	76.4	107.1	62.7
	90	102.0	95.2	107.9	91.4	117.6	80.7	97.8	91.5	103.1	88.3	112.3	78.1	93.4	87.8	98.2	85.1	106.8	75.4
2400	75	99.5	77.2	110.6	60.8	125.6	37.5	94.9	74.4	105.5	58.6	120.0	35.9	90.2	71.7	100.2	56.4	114.1	34.2
	80	101.2	88.0	110.3	75.6	123.4	56.3	96.7	84.8	105.3	73.1	117.8	54.3	92.0	81.7	100.1	70.5	112.0	52.3
	85	104.0	96.4	111.2	88.1	122.3	72.8	99.6	92.9	106.2	85.1	116.8	70.4	94.9	89.4	101.0	82.2	111.1	68.0
	90	108.0	102.4	113.2	98.2	122.4	86.9	103.6	98.6	108.3	94.8	116.9	84.1	99.0	94.7	103.2	91.5	111.2	81.3
2800	75	103.4	82.1	114.0	65.2	128.4	41.4	98.7	79.2	108.7	62.9	122.6	39.6	93.8	76.3	103.2	60.5	116.6	37.8
	80	105.6	93.5	114.2	80.7	126.7	60.9	101.0	90.2	109.0	77.9	120.9	58.7	96.1	86.9	103.6	75.2	115.0	56.4
	85	109.0	102.5	115.6	93.7	126.1	77.9	104.4	98.9	110.4	90.6	120.4	75.4	99.5	95.2	105.1	87.5	114.5	72.7
	90	113.4	109.2	118.1	104.4	126.6	92.7	108.9	105.2	113.0	100.9	121.0	89.7	104.1	101.1	107.7	97.4	115.1	86.7
3200	75	106.9	86.6	116.8	69.2	130.7	44.8	102.0	83.5	111.4	66.7	124.7	42.8	96.9	80.4	105.8	64.1	118.5	40.8
	80	109.6	98.6	117.6	85.2	129.5	64.9	104.7	95.1	112.2	82.3	123.5	62.5	99.7	91.7	106.6	79.4	117.4	60.1
	85	113.4	108.2	119.4	98.9	129.3	82.6	108.6	104.4	114.1	95.6	123.5	79.8	103.6	100.5	108.5	92.3	117.4	77.0
	90	118.4	115.5	122.4	110.2	130.4	97.9	113.6	111.3	117.1	106.5	124.6	94.7	108.7	107.1	111.7	102.8	118.5	91.6
3600	75	109.8	90.6	119.2	72.6	132.5	47.8	104.8	87.3	113.6	69.9	126.3	45.6	99.5	84.1	107.8	67.2	119.9	43.4
	80	113.0	103.2	120.4	89.3	131.7	68.4	108.0	99.5	114.9	86.2	125.6	65.9	102.8	95.9	109.1	83.1	119.3	63.3
	85	117.3	113.4	122.8	103.5	132.1	86.7	112.4	109.4	117.3	100.1	126.0	83.8	107.2	105.4	111.5	96.6	119.8	80.8
	90	122.8	121.3	126.3	115.4	133.6	102.6	117.9	116.9	120.8	111.6	127.6	99.3	112.7	112.5	115.1	107.7	121.4	96.0
4000	75	112.3	94.0	121.1	75.6	133.7	50.2	107.0	90.6	115.3	72.7	127.4	47.9	101.6	87.2	109.3	69.8	120.8	45.5
	80	115.9	107.2	122.8	92.8	133.5	71.5	110.7	103.5	117.0	89.6	127.2	68.7	105.3	99.7	111.1	86.3	120.7	66.0
	85	120.8	118.1	125.6	107.7	134.3	90.3	115.6	113.9	119.9	104.1	128.1	87.2	110.2	109.7	114.0	100.4	121.7	84.1
	90	126.7	126.6	129.6	120.2	136.4	106.9	121.6	121.6	123.9	116.2	130.2	103.4	116.3	116.3	118.1	112.1	123.8	99.9
4400	75	114.2	97.0	122.4	78.1	134.5	52.1	108.8	93.5	116.4	75.0	128.0	49.6	103.1	89.9	110.2	72.0	121.2	47.1
	80	118.4	110.8	124.6	95.9	134.7	74.0	113.0	106.9	118.7	92.5	128.2	71.1	107.4	102.9	112.5	89.0	121.6	68.2
	85	123.7	122.3	127.9	111.4	136.1	93.5	118.3	117.9	122.1	107.6	129.7	90.2	112.8	112.8	116.0	103.7	123.0	86.9
	90	130.1	130.1	132.4	124.5	138.6	110.6	124.8	124.8	126.6	120.3	132.2	107.0	119.3	119.3	120.5	116.1	125.6	103.3
4800	75	115.6	99.5	123.2	80.0	134.7	53.6	110.0	95.8	117.1	76.8	128.0	50.9	104.2	92.0	110.7	73.6	121.1	48.2
	80	120.3	113.9	125.9	98.5	135.4	76.1	114.7	109.8	119.8	94.9	128.8	73.0	109.0	105.7	113.5	91.3	121.9	69.9
	85	126.1	126.0	129.7	114.5	137.3	96.1	120.6	120.6	123.7	110.6	130.7	92.7	114.8	114.8	117.4	106.6	123.9	89.3
	90	133.0	133.0	134.7	128.2	140.3	113.9	127.5	127.5	128.7	123.9	133.8	110.1	121.9	121.9	122.5	119.5	127.0	106.2

**Notes:**

1. All capacities shown are gross and have not considered indoor fan heat. To obtain NET cooling capacity subtract indoor fan heat. For indoor fan heat formula, refer to appropriate airflow table notes.
2. MBh = Total gross capacity
3. SHC = Sensible heat capacity
4. Unit applications below 320 cfm/ton are only applicable on THC models without electric heat. Electric and gas heat applications are restricted to applications 320 cfm/ton and above.

*Note: Table continues on next page*

Table 39. Gross cooling capacities 10 tons high efficiency – three phase T/YHC120F3,4,W (continued)

CFM	Ent DB (°F)	Ambient Temperature (°F)						Ambient Temperature (°F)											
		115						120						125					
		Entering Wet Bulb Temp (°F)						Entering Wet Bulb Temp (°F)						Entering Wet Bulb Temp (°F)					
		61		67		73		61		67		73		61		67		73	
MBh	SHC	MBh	SHC	MBh	SHC	MBh	SHC	MBh	SHC	MBh	SHC	MBh	SHC	MBh	SHC	MBh	SHC		
2000	75	81.2	64.0	91.3	49.8	105.3	28.6	78.8	62.7	88.6	48.7	102.3	27.8	—	—	—	—		
	80	82.6	73.0	90.7	62.8	102.8	45.7	80.2	71.5	88.0	61.6	99.8	44.7	—	—	—	—		
	85	85.1	79.7	91.3	73.5	101.3	60.4	82.7	78.0	88.6	72.1	98.4	59.3	—	—	—	—		
	90	88.8	84.0	93.0	81.9	101.1	72.8	86.4	82.2	90.3	80.3	98.1	71.4	—	—	—	—		
2400	75	85.2	68.9	94.7	54.2	108.1	32.5	82.6	67.6	91.9	53.1	105.0	31.6	—	—	—	—		
	80	87.1	78.6	94.6	67.9	106.0	50.2	84.5	77.0	91.8	66.5	102.9	49.1	—	—	—	—		
	85	90.1	85.9	95.6	79.2	105.1	65.5	87.6	84.1	92.9	77.7	102.0	64.3	—	—	—	—		
	90	94.2	90.8	97.8	88.1	105.3	78.5	91.7	88.8	95.1	86.4	102.3	77.1	—	—	—	—		
2800	75	88.6	73.4	97.5	58.1	110.3	35.9	86.0	71.9	94.6	56.9	107.1	35.0	—	—	—	—		
	80	91.0	83.6	97.9	72.4	108.8	54.2	88.4	82.0	95.0	71.0	105.6	53.1	—	—	—	—		
	85	94.5	91.5	99.5	84.3	108.3	70.1	91.9	89.7	96.6	82.7	105.2	68.8	—	—	—	—		
	90	99.1	97.0	102.1	93.8	109.0	83.7	96.5	95.0	99.3	92.1	105.9	82.2	—	—	—	—		
3200	75	91.6	77.3	99.9	61.6	112.1	38.8	88.8	75.8	96.9	60.3	108.8	37.8	—	—	—	—		
	80	94.4	88.2	100.8	76.4	111.0	57.7	91.7	86.5	97.8	74.9	107.7	56.5	—	—	—	—		
	85	98.4	96.7	102.8	88.9	111.1	74.2	95.7	94.7	99.8	87.3	107.8	72.8	—	—	—	—		
	90	103.5	102.8	105.9	99.1	112.3	88.4	100.8	100.7	103.0	97.2	109.1	86.8	—	—	—	—		
3600	75	94.0	80.8	101.7	64.5	113.3	41.2	91.1	79.2	98.6	63.1	110.0	40.1	—	—	—	106.5 39.0		
	80	97.3	92.3	103.1	80.0	112.7	60.7	94.5	90.4	100.0	78.4	109.4	59.4	—	—	—	106.0 58.1		
	85	101.8	101.4	105.6	93.1	113.3	77.9	99.0	99.0	102.5	91.3	110.0	76.4	—	—	—	106.6 74.9		
	90	107.4	107.4	109.2	103.8	115.0	92.6	104.6	104.6	106.2	101.9	111.7	91.0	—	—	—	108.3 89.3		
4000	75	95.9	83.8	103.0	67.0	114.1	43.2	93.0	82.1	99.8	65.5	110.6	42.0	—	—	—	107.1 40.8		
	80	99.7	95.8	104.9	83.0	114.0	63.3	96.8	93.9	101.7	81.4	110.5	61.9	—	—	—	107.0 60.5		
	85	104.7	104.7	107.9	96.7	115.0	81.0	101.8	101.8	104.7	94.9	111.6	79.4	—	—	—	108.1 77.8		
	90	110.8	110.8	112.0	108.1	117.2	96.4	107.9	107.9	108.9	106.1	113.8	94.6	—	—	—	110.3 92.8		
4400	75	97.3	86.3	103.8	68.9	114.3	44.6	94.3	84.5	100.6	67.4	110.7	43.3	—	—	97.2 65.8	107.1 42.0		
	80	101.6	98.9	106.2	85.6	114.7	65.3	98.6	96.9	102.9	83.9	111.1	63.8	—	—	99.6 82.1	107.6 62.4		
	85	107.0	107.0	109.7	99.9	116.2	83.6	104.1	104.1	106.4	98.0	112.7	82.0	—	—	103.2 96.1	109.1 80.3		
	90	113.6	113.6	114.3	111.9	118.9	99.6	110.7	110.7	111.1	109.7	115.4	97.8	—	—	107.8 107.6	111.9 95.9		
4800	75	98.2	88.3	104.1	70.4	114.0	45.5	95.1	86.4	100.8	68.8	110.3	44.2	—	—	97.3 67.1	106.6 42.8		
	80	103.0	101.5	107.0	87.7	114.9	66.8	99.9	99.5	103.6	85.8	111.2	65.3	—	—	100.2 84.0	107.6 63.7		
	85	108.9	108.9	111.0	102.6	116.9	85.8	105.9	105.9	107.6	100.6	113.3	84.0	—	—	104.3 98.6	109.6 82.3		
	90	116.0	116.0	116.1	115.1	120.0	102.4	113.0	113.0	112.8	112.8	116.5	100.4	—	—	109.4 109.4	112.9 98.5		

Notes:

1. All capacities shown are gross and have not considered indoor fan heat. To obtain NET cooling capacity subtract indoor fan heat. For indoor fan heat formula, refer to appropriate airflow table notes.
2. MBh = Total gross capacity
3. SHC = Sensible heat capacity
4. Unit applications below 320 cfm/ton are only applicable on THC models without electric heat. Electric and gas heat applications are restricted to applications 320 cfm/ton and above.



# Direct Drive - Evaporator Fan Performance

Table 40. Multispeed direct drive evaporator fan performance 3 to 5 tons - standard efficiency - no electric heat

Tons	Model Number	cfm	External Static Pressure (in./water) & Motor Power (Bhp)														
			Speed Set 1			Speed Set 2			Speed Set 3			Speed Set 4			Speed Set 5		
			ESP	rpm	Bhp	ESP	rpm	Bhp	ESP	rpm	Bhp	ESP	rpm	Bhp	ESP	rpm	Bhp
3	TSC036G3,4, W Downflow Airflow	960	0.36	699	0.17	0.75	859	0.29	1.12	1017	0.44	1.57	1157	0.61	—	—	—
		1020	0.30	674	0.17	0.68	841	0.29	1.05	997	0.43	1.48	1139	0.60	—	—	—
		1080	0.24	649	0.16	0.61	822	0.28	0.96	978	0.42	1.38	1121	0.59	—	—	—
		1140	0.18	624	0.15	0.54	804	0.27	0.88	958	0.42	1.29	1102	0.58	—	—	—
		1200	0.11	599	0.15	0.47	785	0.27	0.79	939	0.41	1.20	1084	0.57	1.45	1148	0.71
		1260	0.05	574	0.14	0.40	767	0.26	0.71	919	0.40	1.10	1066	0.56	1.34	1127	0.70
		1320	—	—	—	0.34	749	0.25	0.62	899	0.39	1.01	1047	0.55	1.24	1106	0.68
		1380	—	—	—	0.27	730	0.25	0.54	880	0.38	0.92	1029	0.54	1.13	1085	0.67
	1440	—	—	—	0.20	712	0.24	0.45	860	0.37	0.82	1011	0.53	1.02	1064	0.66	
3	TSC036G3,4, W Horizontal Airflow	960	0.39	676	0.17	0.70	828	0.28	1.05	982	0.43	1.46	1106	0.58	—	—	—
		1020	0.33	650	0.16	0.63	805	0.27	0.97	961	0.42	1.37	1085	0.57	—	—	—
		1080	0.27	625	0.15	0.56	783	0.27	0.90	940	0.41	1.29	1064	0.56	—	—	—
		1140	0.22	599	0.15	0.49	761	0.26	0.82	919	0.40	1.20	1043	0.55	—	—	—
		1200	0.16	574	0.14	0.43	739	0.25	0.75	898	0.39	1.11	1023	0.54	1.59	1171	0.72
		1260	0.10	548	0.14	0.36	716	0.24	0.68	877	0.38	1.02	1002	0.53	1.48	1150	0.71
		1320	0.04	522	0.13	0.29	694	0.24	0.60	856	0.37	0.93	981	0.52	1.38	1128	0.70
		1380	—	—	—	0.22	672	0.23	0.53	835	0.36	0.84	960	0.51	1.28	1107	0.68
	1440	—	—	—	0.16	650	0.22	0.45	814	0.35	0.76	940	0.49	1.17	1085	0.67	
4	TSC048G3,4, W Downflow Airflow	1280	0.60	842	0.33	0.98	1023	0.50	—	—	—	—	—	—	—	—	—
		1360	0.50	811	0.32	0.84	990	0.48	0.94	1112	0.65	1.17	1133	0.77	—	—	—
		1440	0.39	781	0.30	0.70	956	0.46	0.80	1080	0.63	1.02	1098	0.74	—	—	—
		1520	0.29	750	0.29	0.56	922	0.45	0.65	1048	0.61	0.87	1063	0.72	1.30	1210	0.87
		1600	0.18	719	0.28	0.43	889	0.43	0.51	1016	0.59	0.72	1028	0.70	1.19	1181	0.84
		1680	0.08	689	0.27	0.29	855	0.42	0.37	984	0.57	0.57	993	0.67	1.07	1151	0.82
		1760	—	—	—	0.15	821	0.40	0.23	952	0.55	0.42	958	0.65	0.96	1121	0.80
		1840	—	—	—	0.01	787	0.38	0.08	919	0.54	0.28	923	0.63	0.85	1092	0.78
	1920	—	—	—	—	—	—	—	—	0.13	888	0.60	0.73	1062	0.76		
4	TSC048G3,4, W Horizontal Airflow	1280	0.69	872	0.34	0.92	983	0.48	—	—	—	—	—	—	—	—	—
		1360	0.58	839	0.33	0.81	950	0.46	1.14	1078	0.63	1.14	1190	0.81	—	—	—
		1440	0.47	806	0.31	0.70	916	0.44	1.02	1046	0.61	1.01	1159	0.79	—	—	—
		1520	0.35	773	0.30	0.59	883	0.43	0.90	1014	0.59	0.89	1128	0.77	1.42	1200	0.86
		1600	0.24	739	0.29	0.48	850	0.41	0.79	982	0.57	0.77	1097	0.74	1.31	1175	0.84
		1680	0.13	706	0.28	0.37	817	0.40	0.67	950	0.55	0.64	1066	0.72	1.20	1150	0.82
		1760	0.02	673	0.26	0.26	784	0.38	0.55	918	0.54	0.52	1035	0.70	1.09	1125	0.80
		1840	—	—	—	0.15	751	0.36	0.44	886	0.52	0.40	1004	0.68	0.98	1100	0.79
	1920	—	—	—	—	—	—	0.32	854	0.50	0.27	973	0.66	0.87	1075	0.77	
5	TSC060G3,4, W Downflow Airflow	1600	0.79	998	0.57	1.07	1083	0.68	1.31	1183	0.85	—	—	—	—	—	—
		1700	0.62	956	0.55	0.92	1043	0.66	1.12	1144	0.82	1.34	1208	0.97	—	—	—
		1800	0.45	913	0.52	0.77	1004	0.63	0.93	1105	0.79	1.15	1176	0.94	—	—	—
		1900	0.28	870	0.50	0.62	964	0.61	0.74	1066	0.76	0.97	1143	0.92	1.24	1188	1.04
		2000	0.11	828	0.47	0.47	924	0.58	0.54	1027	0.73	0.78	1111	0.89	1.06	1150	1.01
		2100	—	—	—	0.32	885	0.56	0.35	987	0.71	0.60	1078	0.86	0.87	1111	0.97
		2200	—	—	—	0.17	845	0.53	0.16	948	0.68	0.41	1046	0.84	0.69	1073	0.94
		2300	—	—	—	0.02	805	0.51	—	—	—	0.22	1013	0.81	0.50	1035	0.91
	2400	—	—	—	—	—	—	—	—	0.04	980	0.79	0.32	997	0.87		

## Direct Drive - Evaporator Fan Performance

**Table 40. Multispeed direct drive evaporator fan performance 3 to 5 tons - standard efficiency - no electric heat (continued)**

Tons	Model Number	cfm	External Static Pressure (in./water) & Motor Power (Bhp)														
			Speed Set 1			Speed Set 2			Speed Set 3			Speed Set 4			Speed Set 5		
			ESP	rpm	Bhp	ESP	rpm	Bhp	ESP	rpm	Bhp	ESP	rpm	Bhp	ESP	rpm	Bhp
5	TSC060G3,4, W Horizontal Airflow	1600	0.89	1002	0.57	1.04	1049	0.66	1.32	1144	0.82	1.55	1159	0.93	—	—	—
		1700	0.73	959	0.55	0.88	1008	0.63	1.16	1104	0.79	1.39	1119	0.90	—	—	—
		1800	0.57	916	0.52	0.72	966	0.61	0.99	1064	0.76	1.22	1079	0.86	—	—	—
		1900	0.42	872	0.50	0.56	924	0.58	0.83	1024	0.73	1.06	1039	0.83	1.37	1213	1.06
		2000	0.26	829	0.47	0.40	882	0.56	0.67	984	0.70	0.89	999	0.80	1.21	1148	1.00
		2100	0.11	769	0.44	0.24	840	0.53	0.51	944	0.68	0.72	959	0.77	1.04	1106	0.97
		2200	—	—	—	0.08	799	0.50	0.34	904	0.65	0.56	918	0.74	0.87	1065	0.93
		2300	—	—	—	—	—	—	0.18	864	0.62	0.39	878	0.70	0.70	1023	0.90
		2400	—	—	—	—	—	—	—	—	—	—	—	—	0.53	982	0.86

**Notes:**

1. For 036 models, fan motor heat (MBh) = 2.72 x Fan Bhp + 0.16. For 048 & 060 models, fan motor heat (MBh) = 2.87 x Fan Bhp + 0.15.
2. Factory supplied motors, in commercial equipment, are definite purpose motors, specifically designed and tested to operate reliably and continuously at all cataloged conditions. Using the full horsepower range of our fan motors as shown in our tabular data will not result in nuisance tripping or premature motor failure. Our product's warranty will not be affected.
3. For electric heat applications, minimum airflow is set to 320/ton, unless specified otherwise, values found in electric heat temperature rise table.
4. Data includes pressure drop due to wet coil and filters.



## Direct Drive - Evaporator Fan Performance

**Table 41. Multispeed direct drive evaporator fan performance 3 to 5 tons - standard efficiency - no electric heat – oversized motor**

Tons	Model Number	cfm	External Static Pressure (in./water) & Motor Power (Bhp)															
			Speed Set 1			Speed Set 2			Speed Set 3			Speed Set 4			Speed Set 5			
			ESP	rpm	Bhp	ESP	rpm	Bhp	ESP	rpm	Bhp	ESP	rpm	Bhp	ESP	rpm	Bhp	
3	TSC036G3,4, W Downflow Airflow	960	1.16	967	0.44	—	—	—	—	—	—	—	—	—	—	—	—	—
		1020	1.07	948	0.43	—	—	—	—	—	—	—	—	—	—	—	—	—
		1080	0.99	928	0.42	—	—	—	—	—	—	—	—	—	—	—	—	—
		1140	0.90	908	0.41	1.44	1101	0.66	—	—	—	—	—	—	—	—	—	—
		1200	0.81	889	0.40	1.35	1082	0.64	1.48	1127	0.71	—	—	—	—	—	—	—
		1260	0.73	869	0.39	1.26	1062	0.63	1.39	1107	0.70	—	—	—	—	—	—	—
		1320	0.64	849	0.38	1.18	1042	0.62	1.30	1087	0.68	1.51	1163	0.80	—	—	—	—
		1380	0.55	830	0.38	1.09	1023	0.61	1.22	1068	0.67	1.43	1143	0.78	—	—	—	—
		1440	0.47	810	0.37	1.00	1003	0.60	1.13	1048	0.66	1.34	1124	0.77	1.45	1164	0.83	—
3	TSC036G3,4, W Horizontal Airflow	960	1.00	1009	0.46	1.42	1200	0.71	—	—	—	—	—	—	—	—	—	
		1020	0.92	986	0.45	1.35	1177	0.70	1.45	1221	0.77	—	—	—	—	—	—	
		1080	0.85	963	0.44	1.28	1154	0.69	1.38	1199	0.75	—	—	—	—	—	—	
		1140	0.78	941	0.43	1.21	1132	0.67	1.31	1176	0.74	1.48	1251	0.86	—	—	—	
		1200	0.71	918	0.42	1.14	1109	0.66	1.24	1153	0.72	1.40	1228	0.84	1.49	1268	0.91	—
		1260	0.64	895	0.40	1.06	1086	0.65	1.16	1131	0.71	1.33	1206	0.82	1.42	1245	0.89	—
		1320	0.56	872	0.39	0.99	1063	0.63	1.09	1108	0.70	1.26	1183	0.81	1.35	1223	0.87	—
		1380	0.49	850	0.38	0.92	1041	0.62	1.02	1085	0.68	1.19	1160	0.79	1.28	1200	0.86	—
		1440	0.42	827	0.37	0.85	1018	0.61	0.95	1063	0.67	1.12	1137	0.78	1.21	1177	0.84	—
4	TSC048G3,4, W Downflow Airflow	1280	1.15	1023	0.58	—	—	—	—	—	—	—	—	—	—	—	—	
		1360	1.03	997	0.57	1.42	1137	0.77	—	—	—	—	—	—	—	—	—	
		1440	0.91	971	0.55	1.30	1111	0.75	—	—	—	—	—	—	—	—	—	
		1520	0.80	945	0.54	1.19	1085	0.73	—	—	—	—	—	—	—	—	—	
		1600	0.68	919	0.52	1.07	1059	0.71	1.54	1224	0.98	—	—	—	—	—	—	
		1680	0.57	893	0.51	0.96	1032	0.70	1.42	1198	0.96	—	—	—	—	—	—	
		1760	0.45	866	0.49	0.84	1006	0.68	1.30	1172	0.93	—	—	—	—	—	—	
		1840	0.34	840	0.48	0.73	980	0.66	1.19	1146	0.91	1.55	1274	1.14	—	—	—	
		1920	0.22	814	0.46	0.61	954	0.64	1.07	1120	0.89	1.43	1248	1.11	1.54	1289	1.19	—
4	TSC048G3,4, W Horizontal Airflow	1280	0.97	1047	0.60	1.28	1185	0.80	—	—	—	—	—	—	—	—	—	
		1360	0.87	1017	0.58	1.18	1155	0.78	—	—	—	—	—	—	—	—	—	
		1440	0.78	986	0.56	1.09	1125	0.76	1.46	1289	1.03	—	—	—	—	—	—	
		1520	0.68	956	0.55	0.99	1094	0.74	1.36	1258	1.00	—	—	—	—	—	—	
		1600	0.59	926	0.53	0.90	1064	0.72	1.26	1228	0.98	—	—	—	—	—	—	
		1680	0.49	896	0.51	0.80	1034	0.70	1.17	1198	0.96	1.45	1325	1.18	—	—	—	
		1760	0.39	865	0.49	0.70	1004	0.68	1.07	1168	0.93	1.36	1295	1.16	1.45	1335	1.23	—
		1840	0.30	835	0.48	0.61	973	0.66	0.98	1137	0.91	1.26	1265	1.13	1.35	1305	1.20	—
		1920	0.20	805	0.46	0.51	943	0.64	0.88	1107	0.88	1.17	1234	1.10	1.26	1274	1.18	—
5	TSC060G3,4, W Downflow Airflow	1600	—	—	—	—	—	—	—	—	—	—	—	—	—	—	—	
		1700	1.36	1141	0.83	—	—	—	—	—	—	—	—	—	—	—	—	
		1800	1.17	1107	0.80	1.43	1193	0.95	—	—	—	—	—	—	—	—	—	
		1900	0.99	1073	0.78	1.25	1159	0.92	—	—	—	—	—	—	—	—	—	
		2000	0.80	1038	0.75	1.06	1125	0.90	1.49	1265	1.16	—	—	—	—	—	—	
		2100	0.62	1004	0.73	0.88	1090	0.87	1.30	1231	1.12	1.45	1280	1.22	—	—	—	
		2200	0.43	970	0.70	0.69	1056	0.84	1.12	1197	1.09	1.26	1245	1.19	1.55	1339	1.38	—
		2300	0.25	935	0.68	0.51	1022	0.81	0.93	1162	1.06	1.08	1211	1.16	1.36	1305	1.35	—
		2400	0.06	901	0.65	0.32	987	0.79	0.74	1128	1.03	0.89	1177	1.12	1.17	1271	1.31	—



## Direct Drive - Evaporator Fan Performance

**Table 41. Multispeed direct drive evaporator fan performance 3 to 5 tons - standard efficiency - no electric heat – oversized motor (continued)**

Tons	Model Number	cfm	External Static Pressure (in./water) & Motor Power (Bhp)														
			Speed Set 1			Speed Set 2			Speed Set 3			Speed Set 4			Speed Set 5		
			ESP	rpm	Bhp	ESP	rpm	Bhp	ESP	rpm	Bhp	ESP	rpm	Bhp	ESP	rpm	Bhp
5	TSC060G3,4, W Horizontal Airflow	1600	1.16	1199	0.87	1.34	1289	1.03	—	—	—	—	—	—	—	—	—
		1700	1.04	1162	0.84	1.23	1251	1.00	1.53	1398	1.28	—	—	—	—	—	—
		1800	0.92	1124	0.82	1.11	1214	0.97	1.41	1360	1.24	1.51	1411	1.35	—	—	—
		1900	0.80	1087	0.79	0.99	1176	0.94	1.29	1323	1.21	1.39	1374	1.31	—	—	—
		2000	0.69	1049	0.76	0.87	1139	0.91	1.17	1286	1.17	1.27	1336	1.28	1.47	1434	1.48
		2100	0.57	1012	0.73	0.75	1101	0.88	1.05	1248	1.14	1.16	1299	1.24	1.36	1397	1.44
		2200	0.45	974	0.71	0.63	1064	0.85	0.93	1211	1.11	1.04	1261	1.20	1.24	1359	1.40
		2300	0.33	937	0.68	0.51	1027	0.82	0.81	1173	1.07	0.92	1224	1.17	1.12	1322	1.36
		2400	0.21	899	0.65	0.39	989	0.79	0.69	1136	1.04	0.80	1187	1.13	1.00	1284	1.33

**Notes:**

1. For 036 models, fan motor heat (MBh) = 2.72 x Fan Bhp + 0.16. For 048 & 060 models, fan motor heat (MBh) = 2.87 x Fan Bhp + 0.15.
2. Factory supplied motors, in commercial equipment, are definite purpose motors, specifically designed and tested to operate reliably and continuously at all cataloged conditions. Using the full horsepower range of our fan motors as shown in our tabular data will not result in nuisance tripping or premature motor failure. Our product's warranty will not be affected.
3. For electric heat applications, minimum airflow is set to 320/ton, unless specified otherwise, values found in electric heat temperature rise table.
4. Data includes pressure drop due to wet coil and filters.



## Direct Drive - Evaporator Fan Performance

**Table 42. Multispeed direct drive evaporator fan performance 3 to 5 tons — standard efficiency — low & medium gas heat**

Tons	Model Number	cfm	External Static Pressure (in./water) & Motor Power (Bhp)														
			Speed Set 1			Speed Set 2			Speed Set 3			Speed Set 4			Speed Set 5		
			ESP	rpm	Bhp	ESP	rpm	Bhp	ESP	rpm	Bhp	ESP	rpm	Bhp	ESP	rpm	Bhp
3	YSC036G3,4, W Downflow Airflow	960	0.39	689	0.18	0.72	853	0.29	1.10	998	0.43	1.53	1136	0.61	—	—	—
		1020	0.32	663	0.17	0.64	832	0.28	1.02	978	0.42	1.43	1117	0.60	—	—	—
		1080	0.25	637	0.16	0.56	811	0.28	0.93	958	0.42	1.34	1099	0.59	—	—	—
		1140	0.18	612	0.16	0.48	790	0.27	0.84	938	0.41	1.24	1080	0.58	—	—	—
		1200	0.11	586	0.15	0.40	769	0.26	0.75	918	0.40	1.15	1061	0.57	1.47	1162	0.71
		1260	0.04	561	0.14	0.32	748	0.25	0.67	898	0.39	1.05	1043	0.56	1.39	1143	0.69
		1320	—	—	—	0.25	726	0.25	0.58	878	0.38	0.96	1024	0.55	1.30	1123	0.68
		1380	—	—	—	0.17	705	0.24	0.49	858	0.37	0.86	1005	0.54	1.22	1104	0.67
		1440	—	—	—	0.09	684	0.23	0.41	838	0.36	0.77	987	0.53	1.13	1084	0.66
3	YSC036G3,4, W Horizontal Airflow	960	0.42	681	0.17	0.70	839	0.29	1.05	982	0.43	1.42	1099	0.59	—	—	—
		1020	0.35	656	0.17	0.63	816	0.28	0.97	961	0.42	1.34	1080	0.58	—	—	—
		1080	0.28	630	0.16	0.56	793	0.27	0.90	940	0.41	1.25	1061	0.57	—	—	—
		1140	0.22	605	0.15	0.49	770	0.26	0.82	919	0.40	1.17	1042	0.56	1.46	1152	0.70
		1200	0.15	579	0.15	0.43	747	0.25	0.75	898	0.39	1.09	1023	0.55	1.39	1135	0.69
		1260	0.08	554	0.14	0.36	724	0.25	0.68	877	0.38	1.01	1005	0.54	1.33	1117	0.68
		1320	0.01	528	0.14	0.29	701	0.24	0.60	856	0.37	0.93	986	0.53	1.26	1100	0.67
		1380	—	—	—	0.22	678	0.23	0.53	835	0.36	0.85	967	0.52	1.19	1083	0.66
		1440	—	—	—	0.16	655	0.22	0.45	814	0.35	0.77	948	0.51	1.12	1066	0.65
4	YSC048G3,4, W Downflow Airflow	1280	0.67	887	0.36	0.84	994	0.46	—	—	—	—	—	—	—	—	—
		1360	0.55	854	0.34	0.70	959	0.45	0.94	1049	0.56	1.17	1133	0.68	—	—	—
		1440	0.44	821	0.33	0.57	924	0.43	0.80	1015	0.54	1.02	1098	0.66	—	—	—
		1520	0.32	788	0.32	0.44	889	0.41	0.65	980	0.52	0.87	1063	0.64	1.47	1210	0.87
		1600	0.20	755	0.30	0.30	854	0.40	0.51	945	0.50	0.72	1028	0.61	1.32	1181	0.84
		1680	0.08	722	0.29	0.17	819	0.38	0.37	910	0.48	0.57	993	0.59	1.17	1151	0.82
		1760	—	—	—	0.03	783	0.37	0.23	876	0.47	0.42	958	0.57	1.03	1121	0.80
		1840	—	—	—	—	—	—	0.08	841	0.45	0.28	923	0.55	0.88	1092	0.78
		1920	—	—	—	—	—	—	—	—	0.13	888	0.53	0.73	1062	0.76	
4	YSC048G3,4, W Horizontal Airflow	1280	0.69	872	0.35	0.83	934	0.44	—	—	—	—	—	—	—	—	—
		1360	0.58	839	0.34	0.72	902	0.42	0.91	980	0.52	1.09	1057	0.63	—	—	—
		1440	0.47	806	0.32	0.62	869	0.41	0.80	948	0.50	0.97	1026	0.61	—	—	—
		1520	0.35	773	0.31	0.51	837	0.39	0.69	915	0.49	0.86	994	0.59	1.47	1204	0.86
		1600	0.24	739	0.30	0.40	804	0.38	0.58	883	0.47	0.74	962	0.57	1.33	1173	0.84
		1680	0.13	706	0.28	0.30	772	0.36	0.47	851	0.45	0.62	931	0.56	1.20	1142	0.82
		1760	0.02	673	0.27	0.19	739	0.34	0.36	819	0.44	0.51	899	0.54	1.06	1112	0.80
		1840	—	—	—	0.09	707	0.33	0.25	787	0.42	0.39	868	0.52	0.93	1081	0.77
		1920	—	—	—	—	—	—	0.13	755	0.40	0.28	836	0.50	0.79	1051	0.75
5	YSC060G3,4, W Downflow Airflow	1600	0.79	998	0.58	1.07	1083	0.69	1.31	1183	0.83	—	—	—	—	—	—
		1700	0.62	956	0.55	0.92	1043	0.67	1.12	1144	0.80	1.21	1179	0.89	—	—	—
		1800	0.45	913	0.53	0.77	1004	0.64	0.93	1105	0.77	1.01	1136	0.86	—	—	—
		1900	0.28	870	0.50	0.62	964	0.62	0.74	1066	0.75	0.82	1094	0.83	1.23	1188	1.02
		2000	0.11	828	0.48	0.47	924	0.59	0.54	1027	0.72	0.62	1052	0.80	1.03	1150	0.99
		2100	—	—	—	0.32	885	0.57	0.35	987	0.69	0.43	1009	0.76	0.82	1111	0.96
		2200	—	—	—	0.17	845	0.54	0.16	948	0.66	0.23	967	0.73	0.61	1073	0.93
		2300	—	—	—	0.02	805	0.52	—	—	—	0.04	924	0.70	0.40	1035	0.89
		2400	—	—	—	—	—	—	—	—	—	—	0.20	997	0.86		

## Direct Drive - Evaporator Fan Performance

**Table 42. Multispeed direct drive evaporator fan performance 3 to 5 tons — standard efficiency — low & medium gas heat (continued)**

Tons	Model Number	cfm	External Static Pressure (in./water) & Motor Power (Bhp)														
			Speed Set 1			Speed Set 2			Speed Set 3			Speed Set 4			Speed Set 5		
			ESP	rpm	Bhp	ESP	rpm	Bhp	ESP	rpm	Bhp	ESP	rpm	Bhp	ESP	rpm	Bhp
5	YSC060G3,4, W Horizontal Airflow	1600	0.84	989	0.57	0.97	1049	0.67	1.16	1144	0.80	1.32	1159	0.88	—	—	—
		1700	0.68	945	0.55	0.82	1008	0.65	1.00	1104	0.77	1.16	1119	0.85	—	—	—
		1800	0.52	901	0.52	0.66	966	0.62	0.84	1064	0.74	1.00	1079	0.82	—	—	—
		1900	0.36	857	0.49	0.51	924	0.59	0.68	1024	0.72	0.84	1039	0.79	1.26	1189	1.03
		2000	0.20	813	0.47	0.36	882	0.57	0.52	984	0.69	0.67	999	0.76	1.07	1148	0.99
		2100	0.04	769	0.44	0.21	840	0.54	0.36	944	0.66	0.51	959	0.73	0.89	1106	0.95
		2200	—	—	—	0.05	799	0.51	0.20	904	0.63	0.35	918	0.70	0.70	1065	0.92
		2300	—	—	—	—	—	—	0.04	864	0.60	0.19	878	0.67	0.52	1023	0.88
		2400	—	—	—	—	—	—	—	—	—	0.03	838	0.64	0.33	982	0.85

**Notes:**

1. For 036 models, fan motor heat (MBh) = 2.72 x Fan Bhp + 0.16. For 048 & 060 models, fan motor heat (MBh) = 2.87 x Fan Bhp + 0.15.
2. Factory supplied motors, in commercial equipment, are definite purpose motors, specifically designed and tested to operate reliably and continuously at all cataloged conditions. Using the full horsepower range of our fan motors as shown in our tabular data will not result in nuisance tripping or premature motor failure. Our product's warranty will not be affected.
3. Data includes pressure drop due to wet coil and filters.



## Direct Drive - Evaporator Fan Performance

**Table 43. Multispeed direct drive evaporator fan performance 3 to 5 tons — standard efficiency — low & medium gas heat — oversized motor**

Tons	Model Number	cfm	External Static Pressure (in./water) & Motor Power (Bhp)														
			Speed Set 1			Speed Set 2			Speed Set 3			Speed Set 4			Speed Set 5		
			ESP	rpm	Bhp	ESP	rpm	Bhp	ESP	rpm	Bhp	ESP	rpm	Bhp	ESP	rpm	Bhp
3	YSC036G3,4, W Downflow Airflow	960	1.16	967	0.44	—	—	—	—	—	—	—	—	—	—	—	—
		1020	1.07	948	0.43	—	—	—	—	—	—	—	—	—	—	—	—
		1080	0.99	928	0.42	—	—	—	—	—	—	—	—	—	—	—	—
		1140	0.90	908	0.41	1.44	1101	0.66	—	—	—	—	—	—	—	—	—
		1200	0.81	889	0.40	1.35	1082	0.64	1.48	1127	0.71	—	—	—	—	—	—
		1260	0.73	869	0.39	1.26	1062	0.63	1.39	1107	0.70	—	—	—	—	—	—
		1320	0.64	849	0.38	1.18	1042	0.62	1.30	1087	0.68	—	—	—	—	—	—
		1380	0.55	830	0.38	1.09	1023	0.61	1.22	1068	0.67	1.43	1143	0.78	—	—	—
		1440	0.47	810	0.37	1.00	1003	0.60	1.13	1048	0.66	1.34	1124	0.77	1.45	1164	0.83
3	YSC036G3,4, W Horizontal Airflow	960	1.00	1009	0.46	1.42	1200	0.71	—	—	—	—	—	—	—	—	
		1020	0.92	986	0.45	1.35	1177	0.70	1.45	1221	0.77	—	—	—	—	—	
		1080	0.85	963	0.44	1.28	1154	0.69	1.38	1199	0.75	—	—	—	—	—	
		1140	0.78	941	0.43	1.21	1132	0.67	1.31	1176	0.74	1.48	1251	0.86	—	—	—
		1200	0.71	918	0.42	1.14	1109	0.66	1.24	1153	0.72	1.40	1228	0.84	1.49	1268	0.91
		1260	0.64	895	0.40	1.06	1086	0.65	1.16	1131	0.71	1.33	1206	0.82	1.42	1245	0.89
		1320	0.56	872	0.39	0.99	1063	0.63	1.09	1108	0.70	1.26	1183	0.81	1.35	1223	0.87
		1380	0.49	850	0.38	0.92	1041	0.62	1.02	1085	0.68	1.19	1160	0.79	1.28	1200	0.86
		1440	0.42	827	0.37	0.85	1018	0.61	0.95	1063	0.67	1.12	1137	0.78	1.21	1177	0.84
4	YSC048G3,4, W Downflow Airflow	1280	1.15	1023	0.58	—	—	—	—	—	—	—	—	—	—	—	
		1360	1.03	997	0.57	1.42	1137	0.77	—	—	—	—	—	—	—	—	
		1440	0.91	971	0.55	1.30	1111	0.75	—	—	—	—	—	—	—	—	
		1520	0.80	945	0.54	1.19	1085	0.73	—	—	—	—	—	—	—	—	
		1600	0.68	919	0.52	1.07	1059	0.71	1.54	1224	0.98	—	—	—	—	—	—
		1680	0.57	893	0.51	0.96	1032	0.70	1.42	1198	0.96	1.55	1246	1.04	—	—	—
		1760	0.45	866	0.49	0.84	1006	0.68	1.30	1172	0.93	1.44	1220	1.02	—	—	—
		1840	0.34	840	0.48	0.73	980	0.66	1.19	1146	0.91	1.32	1194	0.99	1.55	1274	1.14
		1920	0.22	814	0.46	0.61	954	0.64	1.07	1120	0.89	1.21	1168	0.97	1.43	1248	1.11
4	YSC048G3,4, W Horizontal Airflow	1280	0.97	1047	0.60	1.28	1185	0.80	—	—	—	—	—	—	—	—	
		1360	0.87	1017	0.58	1.18	1155	0.78	—	—	—	—	—	—	—	—	
		1440	0.78	986	0.56	1.09	1125	0.76	1.46	1289	1.03	—	—	—	—	—	
		1520	0.68	956	0.55	0.99	1094	0.74	1.36	1258	1.00	1.47	1306	1.09	—	—	—
		1600	0.59	926	0.53	0.90	1064	0.72	1.26	1228	0.98	1.37	1276	1.06	1.55	1355	1.21
		1680	0.49	896	0.51	0.80	1034	0.70	1.17	1198	0.96	1.28	1246	1.04	1.45	1325	1.18
		1760	0.39	865	0.49	0.70	1004	0.68	1.07	1168	0.93	1.18	1215	1.01	1.36	1295	1.16
		1840	0.30	835	0.48	0.61	973	0.66	0.98	1137	0.91	1.08	1185	0.99	1.26	1265	1.13
		1920	0.20	805	0.46	0.51	943	0.64	0.88	1107	0.88	0.99	1155	0.96	1.17	1234	1.10
5	YSC060G3,4, W Downflow Airflow	1600	1.44	1134	0.82	—	—	—	—	—	—	—	—	—	—	—	
		1700	1.25	1100	0.80	1.51	1182	0.94	—	—	—	—	—	—	—	—	
		1800	1.05	1066	0.77	1.31	1148	0.92	—	—	—	—	—	—	—	—	
		1900	0.85	1031	0.75	1.11	1113	0.89	1.53	1247	1.14	—	—	—	—	—	—
		2000	0.65	997	0.72	0.91	1079	0.86	1.34	1213	1.11	1.48	1260	1.20	—	—	—
		2100	0.45	963	0.70	0.71	1045	0.83	1.14	1179	1.08	1.29	1225	1.17	—	—	—
		2200	0.26	929	0.67	0.52	1011	0.81	0.94	1145	1.05	1.09	1191	1.14	1.37	1281	1.32
		2300	0.06	894	0.65	0.32	976	0.78	0.74	1110	1.01	0.89	1157	1.10	1.17	1246	1.29
		2400	—	—	—	0.12	942	0.75	0.54	1076	0.98	0.69	1123	1.07	0.98	1212	1.25

## Direct Drive - Evaporator Fan Performance

**Table 43. Multispeed direct drive evaporator fan performance 3 to 5 tons — standard efficiency — low & medium gas heat — oversized motor (continued)**

Tons	Model Number	cfm	External Static Pressure (in./water) & Motor Power (Bhp)														
			Speed Set 1			Speed Set 2			Speed Set 3			Speed Set 4			Speed Set 5		
			ESP	rpm	Bhp	ESP	rpm	Bhp	ESP	rpm	Bhp	ESP	rpm	Bhp	ESP	rpm	Bhp
5	YSC060G3,4, W Horizontal Airflow	1600	1.06	1152	0.84	1.24	1238	0.99	—	—	—	—	—	—	—	—	—
		1700	0.93	1114	0.81	1.11	1200	0.96	1.41	1341	1.23	1.52	1390	1.33	—	—	—
		1800	0.80	1077	0.78	0.98	1163	0.93	1.28	1303	1.19	1.39	1352	1.29	—	—	—
		1900	0.66	1039	0.75	0.85	1125	0.90	1.15	1266	1.16	1.25	1315	1.25	1.46	1409	1.45
		2000	0.53	1002	0.73	0.72	1088	0.87	1.02	1228	1.12	1.12	1277	1.22	1.32	1371	1.42
		2100	0.40	964	0.70	0.59	1050	0.84	0.89	1191	1.09	0.99	1240	1.18	1.19	1334	1.38
		2200	0.27	927	0.67	0.45	1013	0.81	0.76	1153	1.05	0.86	1202	1.15	1.06	1296	1.34
		2300	0.14	889	0.65	0.32	975	0.78	0.62	1116	1.02	0.73	1165	1.11	0.93	1259	1.30
		2400	0.01	852	0.62	0.19	938	0.75	0.49	1078	0.99	0.60	1127	1.08	0.80	1221	1.26

**Notes:**

1. For 036 models, fan motor heat (MBh) = 2.72 x Fan Bhp + 0.16. For 048 & 060 models, fan motor heat (MBh) = 2.87 x Fan Bhp + 0.15.
2. Factory supplied motors, in commercial equipment, are definite purpose motors, specifically designed and tested to operate reliably and continuously at all cataloged conditions. Using the full horsepower range of our fan motors as shown in our tabular data will not result in nuisance tripping or premature motor failure. Our product's warranty will not be affected.
3. Data includes pressure drop due to wet coil and filters.



## Direct Drive - Evaporator Fan Performance

**Table 44. Multispeed direct drive evaporator fan performance 3 to 5 tons — standard efficiency — high gas heat**

Tons	Model Number	cfm	External Static Pressure (in./water) & Motor Power (Bhp)														
			Speed Set 1			Speed Set 2			Speed Set 3			Speed Set 4			Speed Set 5		
			ESP	rpm	Bhp	ESP	rpm	Bhp	ESP	rpm	Bhp	ESP	rpm	Bhp	ESP	rpm	Bhp
3	YSC036G3,4, W Downflow Airflow	960	0.40	699	0.18	0.74	865	0.30	1.14	1017	0.44	1.57	1157	0.62	—	—	—
		1020	0.33	674	0.17	0.66	844	0.29	1.05	997	0.43	1.48	1139	0.61	—	—	—
		1080	0.26	649	0.17	0.58	823	0.28	0.96	978	0.42	1.38	1121	0.60	—	—	—
		1140	0.19	624	0.16	0.50	801	0.27	0.88	958	0.42	1.29	1102	0.59	—	—	—
		1200	0.12	599	0.15	0.43	780	0.27	0.79	939	0.41	1.20	1084	0.58	1.44	1154	0.70
		1260	0.05	574	0.15	0.35	759	0.26	0.71	919	0.40	1.10	1066	0.57	1.35	1135	0.69
		1320	—	—	—	0.27	737	0.25	0.62	899	0.39	1.01	1047	0.56	1.27	1117	0.68
		1380	—	—	—	0.19	716	0.24	0.54	880	0.38	0.92	1029	0.55	1.18	1098	0.67
		1440	—	—	—	0.11	695	0.24	0.45	860	0.37	0.82	1011	0.54	1.09	1079	0.66
3	YSC036G3,4, W Horizontal Airflow	960	0.42	695	0.18	0.70	839	0.29	1.05	982	0.43	1.43	1112	0.60	—	—	—
		1020	0.35	671	0.17	0.63	816	0.28	0.97	961	0.42	1.35	1093	0.59	—	—	—
		1080	0.29	646	0.17	0.56	793	0.27	0.90	940	0.41	1.27	1075	0.58	—	—	—
		1140	0.22	622	0.16	0.49	770	0.26	0.82	919	0.40	1.19	1057	0.57	1.49	1165	0.71
		1200	0.15	597	0.15	0.43	747	0.25	0.75	898	0.39	1.11	1038	0.56	1.41	1147	0.70
		1260	0.09	573	0.15	0.36	724	0.25	0.68	877	0.38	1.03	1020	0.55	1.34	1129	0.69
		1320	0.02	549	0.14	0.29	701	0.24	0.60	856	0.37	0.95	1002	0.54	1.26	1111	0.67
		1380	—	—	—	0.22	678	0.23	0.53	835	0.36	0.87	983	0.53	1.18	1093	0.66
		1440	—	—	—	0.16	655	0.22	0.45	814	0.35	0.79	965	0.52	1.10	1075	0.65
4	YSC048G3,4, W Downflow Airflow	1280	0.60	842	0.34	0.88	1023	0.47	—	—	—	—	—	—	—	—	—
		1360	0.50	811	0.33	0.74	990	0.45	1.18	1112	0.58	1.24	1141	0.66	—	—	—
		1440	0.39	781	0.31	0.60	956	0.44	1.04	1080	0.56	1.09	1107	0.64	—	—	—
		1520	0.29	750	0.30	0.47	922	0.42	0.90	1048	0.54	0.94	1074	0.62	—	—	—
		1600	0.18	719	0.29	0.33	889	0.41	0.76	1016	0.53	0.79	1040	0.60	1.28	1183	0.85
		1680	0.08	689	0.28	0.19	855	0.39	0.62	984	0.51	0.64	1007	0.58	1.13	1154	0.83
		1760	—	—	—	0.06	821	0.38	0.48	952	0.49	0.49	974	0.56	0.99	1126	0.81
		1840	—	—	—	—	—	—	0.34	919	0.48	0.34	940	0.54	0.84	1097	0.78
		1920	—	—	—	—	—	—	0.20	887	0.46	0.18	907	0.52	0.69	1068	0.76
4	YSC048G3,4, W Horizontal Airflow	1280	0.69	883	0.35	0.83	948	0.44	—	—	—	—	—	—	—	—	—
		1360	0.58	850	0.34	0.72	916	0.42	0.94	1007	0.52	1.16	1091	0.63	—	—	—
		1440	0.46	817	0.33	0.61	885	0.41	0.82	975	0.50	1.04	1060	0.61	—	—	—
		1520	0.35	784	0.31	0.51	853	0.39	0.71	944	0.49	0.92	1029	0.59	—	—	—
		1600	0.23	751	0.30	0.40	822	0.38	0.59	912	0.47	0.80	998	0.57	1.33	1181	0.84
		1680	0.12	718	0.29	0.29	790	0.36	0.48	880	0.46	0.68	967	0.56	1.19	1150	0.82
		1760	0.01	685	0.27	0.18	759	0.35	0.37	849	0.44	0.56	936	0.54	1.04	1119	0.80
		1840	—	—	—	0.08	727	0.33	0.25	817	0.42	0.44	905	0.52	0.90	1088	0.78
		1920	—	—	—	—	—	—	0.14	785	0.41	0.32	874	0.50	0.76	1057	0.76
5	YSC060G3,4, W Downflow Airflow	1600	0.79	998	0.58	1.08	1115	0.72	1.31	1193	0.85	—	—	—	—	—	—
		1700	0.62	956	0.56	0.89	1074	0.70	1.11	1151	0.82	1.25	1165	0.91	—	—	—
		1800	0.45	913	0.53	0.71	1032	0.67	0.92	1109	0.79	1.07	1123	0.87	—	—	—
		1900	0.28	870	0.51	0.52	991	0.64	0.73	1067	0.76	0.90	1081	0.84	1.17	1200	1.04
		2000	0.11	828	0.48	0.33	949	0.61	0.53	1025	0.73	0.73	1039	0.81	0.97	1158	1.00
		2100	—	—	—	0.14	908	0.59	0.34	983	0.70	0.56	997	0.77	0.77	1116	0.96
		2200	—	—	—	—	—	—	0.15	941	0.67	0.39	955	0.74	0.57	1074	0.93
		2300	—	—	—	—	—	—	—	—	—	0.21	913	0.71	0.37	1032	0.89
		2400	—	—	—	—	—	—	—	—	0.04	871	0.68	0.17	990	0.85	

## Direct Drive - Evaporator Fan Performance

**Table 44. Multispeed direct drive evaporator fan performance 3 to 5 tons — standard efficiency — high gas heat (continued)**

Tons	Model Number	cfm	External Static Pressure (in./water) & Motor Power (Bhp)														
			Speed Set 1			Speed Set 2			Speed Set 3			Speed Set 4			Speed Set 5		
			ESP	rpm	Bhp	ESP	rpm	Bhp	ESP	rpm	Bhp	ESP	rpm	Bhp	ESP	rpm	Bhp
5	YSC060G3,4, W Horizontal Airflow	1600	0.84	1006	0.59	1.00	1061	0.69	1.20	1132	0.81	1.42	1207	0.94	—	—	—
		1700	0.67	962	0.56	0.84	1017	0.66	1.03	1090	0.78	1.25	1165	0.91	—	—	—
		1800	0.51	918	0.54	0.69	974	0.63	0.87	1047	0.75	1.07	1123	0.87	—	—	—
		1900	0.34	874	0.51	0.53	931	0.60	0.71	1005	0.72	0.90	1081	0.84	1.26	1205	1.04
		2000	0.18	831	0.48	0.37	888	0.57	0.54	963	0.69	0.73	1039	0.81	1.06	1163	1.00
		2100	0.01	787	0.46	0.21	845	0.55	0.38	920	0.65	0.56	997	0.77	0.86	1120	0.97
		2200	—	—	—	0.05	802	0.52	0.21	878	0.62	0.39	955	0.74	0.66	1077	0.93
		2300	—	—	—	—	—	—	0.05	836	0.59	0.21	913	0.71	0.46	1034	0.89
		2400	—	—	—	—	—	—	—	—	—	0.04	871	0.68	0.26	991	0.86

**Notes:**

1. For 036 models, fan motor heat (MBh) = 2.72 x Fan Bhp + 0.16. For 048 & 060 models, fan motor heat (MBh) = 2.87 x Fan Bhp + 0.15.
2. Factory supplied motors, in commercial equipment, are definite purpose motors, specifically designed and tested to operate reliably and continuously at all cataloged conditions. Using the full horsepower range of our fan motors as shown in our tabular data will not result in nuisance tripping or premature motor failure. Our product's warranty will not be affected.
3. Data includes pressure drop due to wet coil and filters.



## Direct Drive - Evaporator Fan Performance

**Table 45. Multispeed direct drive evaporator fan performance 3 to 5 tons — standard efficiency — high gas heat — oversized motor**

Tons	Model Number	cfm	External Static Pressure (in./water) & Motor Power (Bhp)														
			Speed Set 1			Speed Set 2			Speed Set 3			Speed Set 4			Speed Set 5		
			ESP	rpm	Bhp	ESP	rpm	Bhp	ESP	rpm	Bhp	ESP	rpm	Bhp	ESP	rpm	Bhp
3	YSC036G3,4, W Downflow Airflow	960	1.16	967	0.44	—	—	—	—	—	—	—	—	—	—	—	—
		1020	1.07	948	0.43	—	—	—	—	—	—	—	—	—	—	—	—
		1080	0.99	928	0.42	—	—	—	—	—	—	—	—	—	—	—	—
		1140	0.90	908	0.41	1.44	1101	0.66	—	—	—	—	—	—	—	—	—
		1200	0.81	889	0.40	1.35	1082	0.64	1.48	1127	0.71	—	—	—	—	—	—
		1260	0.73	869	0.39	1.26	1062	0.63	1.39	1107	0.70	—	—	—	—	—	—
		1320	0.64	849	0.38	1.18	1042	0.62	1.30	1087	0.68	1.51	1163	0.80	—	—	—
		1380	0.55	830	0.38	1.09	1023	0.61	1.22	1068	0.67	1.43	1143	0.78	1.54	1184	0.85
1440	0.47	810	0.37	1.00	1003	0.60	1.13	1048	0.66	1.34	1124	0.77	1.45	1164	0.83		
3	YSC036G3,4, W Horizontal Airflow	960	1.00	1009	0.46	1.42	1200	0.71	—	—	—	—	—	—	—	—	—
		1020	0.92	986	0.45	1.35	1177	0.70	1.45	1221	0.77	—	—	—	—	—	—
		1080	0.85	963	0.44	1.28	1154	0.69	1.38	1199	0.75	—	—	—	—	—	—
		1140	0.78	941	0.43	1.21	1132	0.67	1.31	1176	0.74	1.48	1251	0.86	—	—	—
		1200	0.71	918	0.42	1.14	1109	0.66	1.24	1153	0.72	1.40	1228	0.84	1.49	1268	0.91
		1260	0.64	895	0.40	1.06	1086	0.65	1.16	1131	0.71	1.33	1206	0.82	1.42	1245	0.89
		1320	0.56	872	0.39	0.99	1063	0.63	1.09	1108	0.70	1.26	1183	0.81	1.35	1223	0.87
		1380	0.49	850	0.38	0.92	1041	0.62	1.02	1085	0.68	1.19	1160	0.79	1.28	1200	0.86
1440	0.42	827	0.37	0.85	1018	0.61	0.95	1063	0.67	1.12	1137	0.78	1.21	1177	0.84		
4	YSC048G3,4, W Downflow Airflow	1280	1.15	1023	0.58	—	—	—	—	—	—	—	—	—	—	—	—
		1360	1.03	997	0.57	1.42	1137	0.77	—	—	—	—	—	—	—	—	—
		1440	0.91	971	0.55	1.30	1111	0.75	—	—	—	—	—	—	—	—	—
		1520	0.80	945	0.54	1.19	1085	0.73	—	—	—	—	—	—	—	—	—
		1600	0.68	919	0.52	1.07	1059	0.71	1.54	1224	0.98	—	—	—	—	—	—
		1680	0.57	893	0.51	0.96	1032	0.70	1.42	1198	0.96	—	—	—	—	—	—
		1760	0.45	866	0.49	0.84	1006	0.68	1.30	1172	0.93	—	—	—	—	—	—
		1840	0.34	840	0.48	0.73	980	0.66	1.19	1146	0.91	1.55	1274	1.14	—	—	—
1920	0.22	814	0.46	0.61	954	0.64	1.07	1120	0.89	1.43	1248	1.11	1.54	1289	1.19		
4	YSC048G3,4, W Horizontal Airflow	1280	0.97	1047	0.60	1.28	1185	0.80	—	—	—	—	—	—	—	—	—
		1360	0.87	1017	0.58	1.18	1155	0.78	—	—	—	—	—	—	—	—	—
		1440	0.78	986	0.56	1.09	1125	0.76	1.46	1289	1.03	—	—	—	—	—	—
		1520	0.68	956	0.55	0.99	1094	0.74	1.36	1258	1.00	—	—	—	—	—	—
		1600	0.59	926	0.53	0.90	1064	0.72	1.26	1228	0.98	—	—	—	—	—	—
		1680	0.49	896	0.51	0.80	1034	0.70	1.17	1198	0.96	1.45	1325	1.18	—	—	—
		1760	0.39	865	0.49	0.70	1004	0.68	1.07	1168	0.93	1.36	1295	1.16	1.45	1335	1.23
		1840	0.30	835	0.48	0.61	973	0.66	0.98	1137	0.91	1.26	1265	1.13	1.35	1305	1.20
1920	0.20	805	0.46	0.51	943	0.64	0.88	1107	0.88	1.17	1234	1.10	1.26	1274	1.18		
5	YSC060G3,4, W Downflow Airflow	1600	1.44	1134	0.82	—	—	—	—	—	—	—	—	—	—	—	—
		1700	1.25	1100	0.80	1.51	1182	0.94	—	—	—	—	—	—	—	—	—
		1800	1.05	1066	0.77	1.31	1148	0.92	—	—	—	—	—	—	—	—	—
		1900	0.85	1031	0.75	1.11	1113	0.89	—	—	—	—	—	—	—	—	—
		2000	0.65	997	0.72	0.91	1079	0.86	1.34	1213	1.11	1.48	1260	1.20	—	—	—
		2100	0.45	963	0.70	0.71	1045	0.83	1.14	1179	1.08	1.29	1225	1.17	—	—	—
		2200	0.26	929	0.67	0.52	1011	0.81	0.94	1145	1.05	1.09	1191	1.14	1.37	1281	1.32
		2300	0.06	894	0.65	0.32	976	0.78	0.74	1110	1.01	0.89	1157	1.10	1.17	1246	1.29
2400	—	—	—	0.12	942	0.75	0.54	1076	0.98	0.69	1123	1.07	0.98	1212	1.25		



## Direct Drive - Evaporator Fan Performance

**Table 45. Multispeed direct drive evaporator fan performance 3 to 5 tons — standard efficiency — high gas heat — oversized motor (continued)**

Tons	Model Number	cfm	External Static Pressure (in./water) & Motor Power (Bhp)														
			Speed Set 1			Speed Set 2			Speed Set 3			Speed Set 4			Speed Set 5		
			ESP	rpm	Bhp	ESP	rpm	Bhp	ESP	rpm	Bhp	ESP	rpm	Bhp	ESP	rpm	Bhp
5	YSC060G3,4, W Horizontal Airflow	1600	1.06	1152	0.84	1.24	1238	0.99	—	—	—	—	—	—	—	—	—
		1700	0.93	1114	0.81	1.11	1200	0.96	1.41	1341	1.23	1.52	1390	1.33	—	—	—
		1800	0.80	1077	0.78	0.98	1163	0.93	1.28	1303	1.19	1.39	1352	1.29	—	—	—
		1900	0.66	1039	0.75	0.85	1125	0.90	1.15	1266	1.16	1.25	1315	1.25	1.46	1409	1.45
		2000	0.53	1002	0.73	0.72	1088	0.87	1.02	1228	1.12	1.12	1277	1.22	1.32	1371	1.42
		2100	0.40	964	0.70	0.59	1050	0.84	0.89	1191	1.09	0.99	1240	1.18	1.19	1334	1.38
		2200	0.27	927	0.67	0.45	1013	0.81	0.76	1153	1.05	0.86	1202	1.15	1.06	1296	1.34
		2300	0.14	889	0.65	0.32	975	0.78	0.62	1116	1.02	0.73	1165	1.11	0.93	1259	1.30
		2400	0.01	852	0.62	0.19	938	0.75	0.49	1078	0.99	0.60	1127	1.08	0.80	1221	1.26

**Notes:**

1. For 036 models, fan motor heat (MBh) = 2.72 x Fan Bhp + 0.16. For 048 & 060 models, fan motor heat (MBh) = 2.87 x Fan Bhp + 0.15.
2. Factory supplied motors, in commercial equipment, are definite purpose motors, specifically designed and tested to operate reliably and continuously at all cataloged conditions. Using the full horsepower range of our fan motors as shown in our tabular data will not result in nuisance tripping or premature motor failure. Our product's warranty will not be affected.
3. Data includes pressure drop due to wet coil and filters.



## Direct Drive - Evaporator Fan Performance

**Table 46. Multispeed direct drive evaporator fan performance 3 to 5 tons — high efficiency — no electric heat**

Tons	Model Number	cfm	External Static Pressure (in./water) & Motor Power (Bhp)														
			Speed Set 1			Speed Set 2			Speed Set 3			Speed Set 4			Speed Set 5		
			ESP	rpm	Bhp	ESP	rpm	Bhp	ESP	rpm	Bhp	ESP	rpm	Bhp	ESP	rpm	Bhp
3	THC036E3,4,W Downflow Airflow	960	0.45	715	0.21	0.74	851	0.31	0.92	929	0.38	1.07	993	0.44	1.25	1053	0.52
		1020	0.39	695	0.20	0.66	826	0.30	0.84	905	0.37	0.99	969	0.43	1.17	1030	0.50
		1080	0.33	675	0.20	0.59	800	0.29	0.77	880	0.36	0.91	945	0.42	1.08	1007	0.49
		1140	0.27	654	0.19	0.51	774	0.28	0.69	855	0.35	0.83	921	0.41	1.00	985	0.48
		1200	0.21	634	0.18	0.43	749	0.27	0.61	831	0.34	0.75	898	0.40	0.91	962	0.47
		1260	0.15	614	0.18	0.35	723	0.26	0.53	806	0.33	0.67	874	0.39	0.83	939	0.46
		1320	0.09	593	0.17	0.28	697	0.25	0.45	782	0.32	0.59	850	0.38	0.74	916	0.45
		1380	0.03	573	0.17	0.20	671	0.24	0.37	757	0.31	0.51	826	0.37	0.66	893	0.44
		1440	—	—	—	0.12	646	0.23	0.29	732	0.30	0.43	802	0.36	0.57	871	0.43
3	THC036E3,4,W Horizontal Airflow	960	0.45	711	0.21	0.70	835	0.30	0.89	913	0.37	1.04	978	0.44	1.21	1037	0.51
		1020	0.39	689	0.20	0.63	811	0.29	0.81	890	0.36	0.96	957	0.43	1.13	1016	0.50
		1080	0.32	667	0.19	0.56	787	0.28	0.73	868	0.35	0.88	935	0.42	1.04	996	0.49
		1140	0.26	644	0.19	0.48	763	0.28	0.65	845	0.34	0.80	913	0.41	0.95	975	0.48
		1200	0.20	622	0.18	0.41	739	0.27	0.57	823	0.33	0.72	892	0.40	0.87	955	0.47
		1260	0.13	599	0.17	0.33	715	0.26	0.50	800	0.32	0.64	870	0.39	0.78	934	0.46
		1320	0.07	577	0.17	0.26	691	0.25	0.42	777	0.32	0.56	848	0.38	0.69	913	0.45
		1380	0.01	555	0.16	0.18	667	0.24	0.34	755	0.31	0.48	826	0.37	0.61	893	0.44
		1440	—	—	—	0.11	642	0.23	0.26	732	0.30	0.40	805	0.36	0.52	872	0.43
4	THC048E3,4,W THC048F3,4,W Downflow Airflow	1280	0.65	805	0.31	0.86	902	0.40	1.04	966	0.48	1.27	1042	0.58	—	—	—
		1360	0.55	769	0.30	0.76	866	0.38	0.94	934	0.46	1.17	1010	0.56	1.43	1113	0.68
		1440	0.46	733	0.28	0.66	830	0.37	0.84	902	0.44	1.06	977	0.54	1.31	1078	0.66
		1520	0.36	696	0.27	0.56	794	0.35	0.74	869	0.43	0.95	944	0.52	1.20	1043	0.64
		1600	0.27	660	0.25	0.46	758	0.33	0.63	837	0.41	0.85	912	0.50	1.08	1009	0.62
		1680	0.17	624	0.24	0.36	722	0.32	0.53	805	0.40	0.74	879	0.49	0.97	974	0.60
		1760	—	—	—	0.26	686	0.30	0.43	772	0.38	0.63	847	0.47	0.85	939	0.58
		1840	—	—	—	0.16	650	0.29	0.33	740	0.36	0.53	814	0.45	0.74	905	0.55
		1920	—	—	—	0.06	614	0.27	0.23	707	0.35	0.42	782	0.43	0.62	870	0.53
4	THC048E3,4,W THC048F3,4,W Horizontal Airflow	1280	0.56	795	0.31	0.77	880	0.39	0.95	967	0.48	1.16	1040	0.57	—	—	—
		1360	0.48	760	0.29	0.67	847	0.37	0.86	935	0.46	1.06	1010	0.56	1.26	1105	0.68
		1440	0.39	725	0.28	0.58	814	0.36	0.76	903	0.44	0.96	980	0.54	1.16	1075	0.66
		1520	0.30	690	0.27	0.48	780	0.34	0.66	871	0.43	0.86	951	0.53	1.06	1045	0.64
		1600	0.22	655	0.25	0.39	747	0.33	0.57	838	0.41	0.76	921	0.51	0.96	1016	0.62
		1680	0.13	619	0.24	0.30	714	0.31	0.47	806	0.40	0.66	891	0.49	0.86	986	0.60
		1760	—	—	—	0.20	681	0.30	0.37	774	0.38	0.56	861	0.48	0.76	956	0.59
		1840	—	—	—	0.11	647	0.29	0.28	742	0.37	0.46	831	0.46	0.66	926	0.57
		1920	—	—	—	0.01	614	0.27	0.18	710	0.35	0.36	802	0.44	0.56	896	0.55
5	THC060E3,4,W THC060F3,4,W Downflow Airflow	1600	0.82	918	0.50	1.04	1002	0.60	1.26	1087	0.72	—	—	—	—	—	—
		1700	0.67	873	0.47	0.89	957	0.58	1.11	1043	0.69	—	—	—	—	—	—
		1800	0.53	828	0.45	0.74	913	0.55	0.96	1000	0.66	1.16	1083	0.78	—	—	—
		1900	0.39	782	0.42	0.59	869	0.52	0.82	957	0.63	1.02	1041	0.75	1.17	1099	0.85
		2000	0.25	737	0.40	0.45	824	0.50	0.67	914	0.60	0.87	999	0.72	1.02	1056	0.82
		2100	0.11	692	0.37	0.30	780	0.47	0.52	870	0.58	0.72	957	0.69	0.87	1014	0.78
		2200	—	—	—	0.15	735	0.44	0.37	827	0.55	0.57	914	0.66	0.71	971	0.75
		2300	—	—	—	0.00	691	0.42	0.22	784	0.52	0.42	872	0.63	0.56	929	0.72
		2400	—	—	—	—	—	—	0.07	741	0.49	0.27	830	0.60	0.41	886	0.68

## Direct Drive - Evaporator Fan Performance

**Table 46. Multispeed direct drive evaporator fan performance 3 to 5 tons — high efficiency — no electric heat (continued)**

Tons	Model Number	cfm	External Static Pressure (in./water) & Motor Power (Bhp)														
			Speed Set 1			Speed Set 2			Speed Set 3			Speed Set 4			Speed Set 5		
			ESP	rpm	Bhp	ESP	rpm	Bhp	ESP	rpm	Bhp	ESP	rpm	Bhp	ESP	rpm	Bhp
5	THC060E3,4,W THC060F3,4,W Horizontal Airflow	1600	0.71	918	0.50	0.91	1001	0.60	1.09	1070	0.71	—	—	—	—	—	—
		1700	0.59	875	0.47	0.78	959	0.58	0.96	1029	0.68	1.11	1102	0.79	—	—	—
		1800	0.46	832	0.45	0.65	916	0.55	0.82	987	0.65	0.97	1063	0.77	—	—	—
		1900	0.33	788	0.43	0.51	874	0.53	0.68	945	0.62	0.84	1023	0.74	1.01	1093	0.85
		2000	0.21	745	0.40	0.38	831	0.50	0.54	903	0.60	0.71	984	0.71	0.87	1052	0.81
		2100	0.08	701	0.38	0.25	788	0.47	0.41	861	0.57	0.57	944	0.68	0.73	1010	0.78
		2200	—	—	—	0.12	746	0.45	0.27	819	0.54	0.44	904	0.65	0.59	968	0.75
		2300	—	—	—	—	—	—	0.13	778	0.51	0.31	865	0.62	0.45	926	0.72
		2400	—	—	—	—	—	—	—	—	—	0.17	825	0.59	0.31	884	0.68

**Notes:**

1. For 036 models, fan motor heat (MBh) = 2.72 x Fan Bhp + 0.16. For 048 & 060 models, fan motor heat (MBh) = 2.87 x Fan Bhp + 0.15.
2. Factory supplied motors, in commercial equipment, are definite purpose motors, specifically designed and tested to operate reliably and continuously at all cataloged conditions. Using the full horsepower range of our fan motors as shown in our tabular data will not result in nuisance tripping or premature motor failure. Our product's warranty will not be affected.
3. For electric heat applications, minimum airflow is set to 320/ton, unless specified otherwise, values found in electric heat temperature rise table.
4. Data includes pressure drop due to wet coil and filters.



## Direct Drive - Evaporator Fan Performance

**Table 47. Multispeed direct drive evaporator fan performance 3 to 5 tons — high efficiency — low & medium gas heat**

Tons	Model Number	cfm	External Static Pressure (in./water) & Motor Power (Bhp)														
			Speed Set 1			Speed Set 2			Speed Set 3			Speed Set 4			Speed Set 5		
			ESP	rpm	Bhp	ESP	rpm	Bhp	ESP	rpm	Bhp	ESP	rpm	Bhp	ESP	rpm	Bhp
3	YHC036E3,4, W*L,M Downflow Airflow	960	0.43	718	0.19	0.64	825	0.27	0.88	923	0.35	1.12	1017	0.46	1.28	1074	0.52
		1020	0.37	696	0.18	0.57	800	0.26	0.80	900	0.35	1.04	997	0.45	1.20	1053	0.51
		1080	0.30	675	0.18	0.49	775	0.26	0.72	877	0.34	0.96	977	0.44	1.11	1033	0.50
		1140	0.24	654	0.17	0.42	749	0.25	0.64	854	0.33	0.87	957	0.43	1.03	1013	0.49
		1200	0.18	633	0.17	0.34	724	0.24	0.56	832	0.32	0.79	938	0.42	0.94	992	0.48
		1260	0.11	612	0.16	0.26	698	0.23	0.48	809	0.31	0.71	918	0.41	0.86	972	0.47
		1320	0.05	590	0.16	0.19	673	0.22	0.39	786	0.30	0.63	898	0.40	0.77	951	0.46
		1380	—	—	—	0.11	647	0.21	0.31	763	0.29	0.55	878	0.39	0.68	931	0.45
1440	—	—	—	0.03	622	0.21	0.23	740	0.28	0.47	859	0.38	0.60	910	0.44		
3	YHC036E3,4, W*L,M Horizontal Airflow	960	0.42	715	0.19	0.67	842	0.28	0.90	937	0.36	1.15	1037	0.46	1.25	1062	0.51
		1020	0.37	695	0.18	0.61	819	0.27	0.83	916	0.35	1.07	1014	0.45	1.18	1047	0.50
		1080	0.31	675	0.18	0.54	796	0.26	0.75	895	0.34	0.99	992	0.44	1.11	1032	0.50
		1140	0.26	654	0.17	0.47	772	0.26	0.68	874	0.34	0.91	970	0.43	1.04	1017	0.49
		1200	0.20	634	0.17	0.41	749	0.25	0.61	853	0.33	0.83	948	0.42	0.97	1002	0.48
		1260	0.14	614	0.16	0.34	725	0.24	0.54	832	0.32	0.75	926	0.41	0.90	987	0.48
		1320	0.09	594	0.16	0.27	702	0.23	0.47	811	0.31	0.67	903	0.40	0.83	972	0.47
		1380	0.03	574	0.15	0.20	678	0.22	0.40	789	0.30	0.59	881	0.39	0.76	957	0.46
1440	—	—	—	0.14	654	0.22	0.33	768	0.29	0.51	859	0.38	0.69	942	0.45		
4	YHC048***L,M Downflow Airflow	1280	0.69	820	0.33	0.88	903	0.41	1.07	969	0.49	1.07	969	0.49	1.27	1039	0.58
		1360	0.59	785	0.32	0.78	869	0.40	0.96	936	0.48	0.96	936	0.48	1.16	1007	0.56
		1440	0.49	750	0.30	0.68	835	0.38	0.86	903	0.46	0.86	903	0.46	1.05	976	0.55
		1520	0.40	714	0.29	0.58	801	0.37	0.75	870	0.44	0.75	870	0.44	0.94	944	0.53
		1600	0.30	679	0.27	0.48	767	0.35	0.65	837	0.42	0.65	837	0.42	0.84	912	0.51
		1680	0.20	643	0.26	0.38	733	0.34	0.54	804	0.41	0.54	804	0.41	0.73	881	0.49
		1760	0.10	608	0.25	0.28	699	0.32	0.44	771	0.39	0.44	771	0.39	0.62	849	0.48
		1840	0.01	572	0.23	0.18	666	0.31	0.33	738	0.37	0.33	738	0.37	0.51	817	0.46
1920	—	—	—	0.08	632	0.29	0.23	705	0.36	0.23	705	0.36	0.41	786	0.44		
4	YHC048***L,M Horizontal Airflow	1280	0.61	813	0.33	0.81	896	0.41	1.00	977	0.50	1.00	977	0.50	1.17	1044	0.58
		1360	0.51	777	0.31	0.70	862	0.40	0.89	944	0.48	0.89	944	0.48	1.06	1011	0.57
		1440	0.42	742	0.30	0.60	828	0.38	0.79	911	0.46	0.79	911	0.46	0.95	979	0.55
		1520	0.32	707	0.28	0.50	794	0.36	0.68	878	0.45	0.68	878	0.45	0.84	946	0.53
		1600	0.22	671	0.27	0.40	760	0.35	0.57	845	0.43	0.57	845	0.43	0.73	913	0.51
		1680	0.13	636	0.26	0.29	725	0.33	0.46	812	0.41	0.46	812	0.41	0.62	881	0.49
		1760	0.03	600	0.24	0.19	691	0.32	0.36	779	0.40	0.36	779	0.40	0.51	848	0.47
		1840	—	—	—	0.09	657	0.30	0.25	746	0.38	0.25	746	0.38	0.40	815	0.46
1920	—	—	—	—	—	—	0.14	713	0.36	0.14	713	0.36	0.29	783	0.44		
5	YHC060***L,M Downflow Airflow	1600	0.90	962	0.55	1.07	1027	0.64	1.28	1099	0.75	—	—	—	—	—	—
		1700	0.76	919	0.53	0.93	985	0.61	1.14	1060	0.72	—	—	—	—	—	—
		1800	0.62	875	0.50	0.78	943	0.59	0.99	1022	0.70	1.15	1092	0.81	—	—	—
		1900	0.48	832	0.48	0.64	900	0.56	0.84	984	0.67	1.00	1051	0.78	1.18	1116	0.89
		2000	0.34	788	0.45	0.49	858	0.53	0.70	945	0.65	0.86	1010	0.75	1.03	1076	0.86
		2100	0.20	745	0.43	0.35	815	0.51	0.55	907	0.62	0.71	969	0.72	0.88	1037	0.83
		2200	0.06	701	0.40	0.20	773	0.48	0.41	868	0.59	0.56	928	0.69	0.73	997	0.80
		2300	—	—	—	0.06	730	0.46	0.26	830	0.57	0.41	887	0.66	0.58	958	0.77
2400	—	—	—	—	—	—	0.12	792	0.54	0.26	846	0.63	0.43	918	0.73		

## Direct Drive - Evaporator Fan Performance

**Table 47. Multispeed direct drive evaporator fan performance 3 to 5 tons — high efficiency — low & medium gas heat (continued)**

Tons	Model Number	cfm	External Static Pressure (in./water) & Motor Power (Bhp)														
			Speed Set 1			Speed Set 2			Speed Set 3			Speed Set 4			Speed Set 5		
			ESP	rpm	Bhp	ESP	rpm	Bhp	ESP	rpm	Bhp	ESP	rpm	Bhp	ESP	rpm	Bhp
5	YHC060***L,M Horizontal Airflow	1600	0.75	944	0.54	0.91	1010	0.63	1.10	1094	0.75	—	—	—	—	—	—
		1700	0.61	899	0.52	0.77	969	0.60	0.96	1052	0.72	1.12	1114	0.82	—	—	—
		1800	0.48	855	0.49	0.63	927	0.58	0.82	1011	0.69	0.97	1074	0.79	—	—	—
		1900	0.34	811	0.47	0.49	885	0.55	0.67	969	0.66	0.83	1035	0.76	1.01	1111	0.89
		2000	0.20	766	0.44	0.35	843	0.53	0.53	928	0.63	0.68	995	0.74	0.87	1070	0.85
		2100	0.07	722	0.42	0.21	801	0.50	0.39	887	0.61	0.54	956	0.71	0.72	1028	0.82
		2200	—	—	—	0.07	759	0.47	0.25	845	0.58	0.39	916	0.68	0.57	987	0.79
		2300	—	—	—	—	—	—	0.10	804	0.55	0.25	877	0.65	0.42	945	0.76
		2400	—	—	—	—	—	—	—	—	—	0.10	837	0.62	0.27	904	0.72

**Notes:**

1. For 036 models, fan motor heat (MBh) = 2.72 x Fan Bhp + 0.16. For 048 & 060 models, fan motor heat (MBh) = 2.87 x Fan Bhp + 0.15.
2. Factory supplied motors, in commercial equipment, are definite purpose motors, specifically designed and tested to operate reliably and continuously at all cataloged conditions. Using the full horsepower range of our fan motors as shown in our tabular data will not result in nuisance tripping or premature motor failure. Our product's warranty will not be affected.
3. Data includes pressure drop due to wet coil and filters.



## Direct Drive - Evaporator Fan Performance

**Table 48. Multispeed direct drive evaporator fan performance 3 to 5 tons – high efficiency – high heat**

Tons	Model Number	cfm	External Static Pressure (in./water) & Motor Power (Bhp)														
			Speed Set 1			Speed Set 2			Speed Set 3			Speed Set 4			Speed Set 5		
			ESP	rpm	Bhp	ESP	rpm	Bhp	ESP	rpm	Bhp	ESP	rpm	Bhp	ESP	rpm	Bhp
3	YHC036E3,4, W*H Downflow Airflow	960	0.43	718	0.19	0.64	825	0.26	0.88	923	0.34	1.12	1017	0.44	1.28	1074	0.51
		1020	0.37	696	0.19	0.57	800	0.26	0.80	900	0.34	1.04	997	0.43	1.20	1053	0.50
		1080	0.30	675	0.18	0.49	775	0.25	0.72	877	0.33	0.96	977	0.42	1.11	1033	0.49
		1140	0.24	654	0.18	0.42	749	0.24	0.64	854	0.32	0.87	957	0.42	1.03	1013	0.48
		1200	0.18	633	0.17	0.34	724	0.23	0.56	832	0.31	0.79	938	0.41	0.94	992	0.47
		1260	0.11	612	0.16	0.26	698	0.22	0.48	809	0.30	0.71	918	0.40	0.86	972	0.46
		1320	0.05	590	0.16	0.19	673	0.21	0.39	786	0.29	0.63	898	0.39	0.77	951	0.45
		1380	—	—	—	0.11	647	0.21	0.31	763	0.28	0.55	878	0.38	0.68	931	0.44
		1440	—	—	—	0.03	622	0.20	0.23	740	0.28	0.47	859	0.37	0.60	910	0.43
3	YHC036E3,4, W*H Horizontal Airflow	960	0.44	732	0.20	0.65	836	0.27	0.87	935	0.35	1.12	1033	0.45	1.25	1078	0.51
		1020	0.37	708	0.19	0.58	811	0.26	0.80	911	0.34	1.03	1010	0.44	1.17	1059	0.50
		1080	0.31	684	0.18	0.51	787	0.25	0.72	886	0.33	0.95	987	0.43	1.09	1040	0.49
		1140	0.24	660	0.18	0.43	762	0.24	0.64	862	0.32	0.87	964	0.42	1.01	1021	0.48
		1200	0.18	636	0.17	0.36	737	0.24	0.56	838	0.31	0.79	941	0.41	0.93	1002	0.47
		1260	0.11	612	0.16	0.29	712	0.23	0.48	814	0.30	0.70	918	0.40	0.85	983	0.47
		1320	0.05	588	0.16	0.21	688	0.22	0.40	789	0.29	0.62	895	0.39	0.77	964	0.46
		1380	—	—	—	0.14	663	0.21	0.32	765	0.28	0.54	872	0.38	0.69	945	0.45
		1440	—	—	—	0.07	638	0.20	0.24	741	0.28	0.45	849	0.37	0.61	926	0.44
4	YHC048***H Downflow Airflow	1280	0.69	833	0.35	0.90	924	0.43	1.07	989	0.51	1.07	989	0.51	1.27	1066	0.61
		1360	0.60	796	0.33	0.80	889	0.42	0.97	956	0.50	0.97	956	0.50	1.17	1033	0.59
		1440	0.50	759	0.32	0.71	855	0.40	0.87	922	0.48	0.87	922	0.48	1.06	1000	0.57
		1520	0.40	722	0.30	0.61	820	0.39	0.77	889	0.46	0.77	889	0.46	0.96	966	0.56
		1600	0.31	684	0.29	0.51	785	0.37	0.67	855	0.44	0.67	855	0.44	0.85	933	0.54
		1680	0.21	647	0.27	0.41	751	0.35	0.57	822	0.43	0.57	822	0.43	0.75	900	0.52
		1760	0.12	610	0.26	0.31	716	0.34	0.47	788	0.41	0.47	788	0.41	0.64	867	0.50
		1840	—	—	—	0.22	681	0.32	0.37	755	0.39	0.37	755	0.39	0.54	834	0.48
		1920	—	—	—	0.12	647	0.30	0.27	721	0.37	0.27	721	0.37	0.43	801	0.46
4	YHC048***H Horizontal Airflow	1280	0.60	822	0.34	0.81	912	0.43	0.97	986	0.51	0.97	986	0.51	1.18	1063	0.61
		1360	0.51	787	0.33	0.70	876	0.41	0.87	952	0.49	0.87	952	0.49	1.07	1031	0.59
		1440	0.41	752	0.31	0.60	840	0.40	0.76	918	0.48	0.76	918	0.48	0.96	998	0.57
		1520	0.31	718	0.30	0.49	805	0.38	0.66	885	0.46	0.66	885	0.46	0.84	966	0.56
		1600	0.22	683	0.29	0.38	769	0.36	0.55	851	0.44	0.55	851	0.44	0.73	933	0.54
		1680	0.12	648	0.27	0.28	733	0.34	0.45	818	0.42	0.45	818	0.42	0.62	901	0.52
		1760	0.03	613	0.26	0.17	697	0.33	0.34	784	0.41	0.34	784	0.41	0.51	868	0.50
		1840	—	—	—	0.07	661	0.31	0.23	750	0.39	0.23	750	0.39	0.40	836	0.48
		1920	—	—	—	—	—	—	0.13	717	0.37	0.13	717	0.37	0.29	803	0.46
5	YHC060***H Downflow Airflow	1600	0.90	955	0.57	1.06	1022	0.66	1.25	1095	0.77	—	—	—	—	—	—
		1700	0.76	910	0.54	0.92	977	0.63	1.11	1052	0.74	1.28	1113	0.85	—	—	—
		1800	0.62	865	0.52	0.77	932	0.60	0.96	1009	0.71	1.13	1072	0.82	—	—	—
		1900	0.47	819	0.49	0.63	888	0.57	0.82	966	0.68	0.98	1031	0.79	1.18	1105	0.91
		2000	0.33	774	0.46	0.49	843	0.54	0.67	922	0.65	0.83	990	0.75	1.02	1062	0.87
		2100	0.19	729	0.44	0.34	798	0.52	0.52	879	0.62	0.68	949	0.72	0.87	1019	0.84
		2200	0.04	683	0.41	0.20	754	0.49	0.38	836	0.59	0.54	908	0.69	0.71	976	0.80
		2300	—	—	—	0.05	709	0.46	0.23	793	0.56	0.39	867	0.66	0.55	933	0.77
		2400	—	—	—	—	—	—	0.09	750	0.53	0.24	826	0.63	0.40	890	0.73

## Direct Drive - Evaporator Fan Performance

**Table 48. Multispeed direct drive evaporator fan performance 3 to 5 tons — high efficiency — high heat (continued)**

Tons	Model Number	cfm	External Static Pressure (in./water) & Motor Power (Bhp)														
			Speed Set 1			Speed Set 2			Speed Set 3			Speed Set 4			Speed Set 5		
			ESP	rpm	Bhp	ESP	rpm	Bhp	ESP	rpm	Bhp	ESP	rpm	Bhp	ESP	rpm	Bhp
5	YHC060***H Horizontal Airflow	1600	0.77	948	0.57	0.95	1016	0.66	1.10	1093	0.77	—	—	—	—	—	—
		1700	0.63	903	0.54	0.80	973	0.63	0.96	1052	0.74	—	—	—	—	—	—
		1800	0.48	859	0.51	0.66	930	0.60	0.81	1012	0.71	1.00	1084	0.83	—	—	—
		1900	0.34	814	0.49	0.51	888	0.57	0.67	971	0.68	0.85	1042	0.79	1.01	1106	0.91
		2000	0.20	770	0.46	0.36	845	0.55	0.52	931	0.65	0.70	1000	0.76	0.86	1063	0.87
		2100	0.06	725	0.43	0.22	803	0.52	0.38	890	0.62	0.55	959	0.73	0.70	1021	0.84
		2200	—	—	—	0.07	760	0.49	0.23	850	0.60	0.39	917	0.70	0.54	979	0.80
		2300	—	—	—	—	—	—	0.09	809	0.57	0.24	875	0.67	0.39	937	0.77
		2400	—	—	—	—	—	—	—	—	0.00	0.09	833	0.63	0.23	894	0.73

**Notes:**

1. For 036 models, fan motor heat (MBh) = 2.72 x Fan Bhp + 0.16. For 048 & 060 models, fan motor heat (MBh) = 2.87 x Fan Bhp + 0.15.
2. Factory supplied motors, in commercial equipment, are definite purpose motors, specifically designed and tested to operate reliably and continuously at all cataloged conditions. Using the full horsepower range of our fan motors as shown in our tabular data will not result in nuisance tripping or premature motor failure. Our product's warranty will not be affected.
3. Data includes pressure drop due to wet coil and filters.



# Evaporator Fan Performance – Standard Efficiency

**Table 49. Belt drive evaporator fan performance – 6 tons standard efficiency – TSC072H3,4,W downflow airflow**

External Static Pressure (Inches of Water Gauge)																						
		0.10"		0.20"		0.30"		0.40"		0.50"		0.60"		0.70"		0.80"		0.90"		1.00"		
CFM	RPM	BHP	RPM	BHP	RPM	BHP	RPM	BHP	RPM	BHP	RPM	BHP	RPM	BHP	RPM	BHP	RPM	BHP	RPM	BHP	RPM	BHP
1-hp Standard Motor & Field Supplied Low Static Drive <sup>(a)</sup>											1-hp Standard Motor & Drive											
1920	—	—	—	—	588	0.35	643	0.43	693	0.50	738	0.57	782	0.65	823	0.73	862	0.81	900	0.89		
2160	—	—	564	0.37	618	0.44	672	0.52	721	0.60	765	0.68	806	0.76	847	0.85	885	0.93	922	1.02		
2400	—	—	602	0.47	652	0.54	701	0.63	750	0.72	794	0.81	834	0.90	873	0.98	909	1.08	945	1.17		
2640	589	0.50	642	0.59	690	0.67	734	0.76	779	0.85	822	0.95	864	1.05	901	1.15	936	1.24	971	1.34		
2880	634	0.63	682	0.74	728	0.82	770	0.91	810	1.01	851	1.11	892	1.22	930	1.33	965	1.44	999	1.54		

External Static Pressure (Inches of Water Gauge)																						
		1.10"		1.20"		1.30"		1.40"		1.50"		1.60"		1.70"		1.80"		1.90"		2.00"		
CFM	RPM	BHP	RPM	BHP	RPM	BHP	RPM	BHP	RPM	BHP	RPM	BHP	RPM	BHP	RPM	BHP	RPM	BHP	RPM	BHP	RPM	BHP
1-hp Standard Motor & High Static Drive Kit (or 2-hp Oversized Motor & Drive)																						
1920	937	0.98	971	1.06	1004	1.14	1037	1.22	1068	1.30	1097	1.38	1127	1.47	1154	1.55	1182	1.64	1210	1.74		
2160	957	1.12	991	1.21	1024	1.30	1057	1.40	1087	1.49	1117	1.58	1146	1.67	1174	1.76	1201	1.85	1227	1.95		
2400	980	1.27	1013	1.37	1046	1.47	1076	1.57	1106	1.68	1137	1.78	1166	1.89	1194	1.99	1220	2.08	1248	2.19		
2640	1004	1.44	1036	1.55	1067	1.65	1098	1.77	1129	1.88	1158	1.99	1185	2.10	1214	2.22	—	—	—	—		
2880	1030	1.64	1061	1.75	1092	1.86	1123	1.98	1151	2.09	1181	2.22	—	—	—	—	—	—	—	—		

**Notes:**

- For standard evaporator fan speed (rpm), reference the standard motor and sheave/fan speed applicable table in the fan performance section.
- Data includes pressure drop due to standard filters and wet coils. No accessories or options are included in pressure drop data.
- To determine static pressure drop due to other options/accessories, refer to the applicable table in the fan performance section.
- 1-hp fan motor heat (MBh) = 2.829 x fan bhp + .4024. 2-hp fan motor heat (MBh) = 3.000 x fan bhp + .5000.
- Factory supplied motors, in commercial equipment, are definite purpose motors, specifically designed and tested to operate reliably and continuously at all cataloged conditions. Using the full horsepower range of our fan motors as shown in our tabular data will not result in nuisance tripping or premature motor failure. Our product's warranty will not be affected.
- For electric heat applications, minimum airflow is set to 320 cfm/ton, unless specified otherwise, values found in electric heat temperature rise table.

<sup>(a)</sup> Field supplied fan sheave AK84 and belt AX36 required.  
<sup>(b)</sup> 1-hp standard motor & high static drive kit (or 2-hp oversized motor & drive)



## Evaporator Fan Performance — Standard Efficiency

**Table 50. Belt drive evaporator fan performance – 6 tons standard efficiency – TSC072H3,4,W horizontal airflow**

External Static Pressure (Inches of Water Gauge)																					
		0.10"		0.20"		0.30"		0.40"		0.50"		0.60"		0.70"		0.80"		0.90"		1.00"	
CFM	RPM	BHP	RPM	BHP	RPM	BHP	RPM	BHP	RPM	BHP	RPM	BHP	RPM	BHP	RPM	BHP	RPM	BHP	RPM	BHP	
<b>1-hp Standard Motor &amp; Field Supplied Low Static Drive<sup>(a)</sup></b>											<b>1-hp Standard Motor &amp; Drive</b>										
1920	—	—	580	0.33	641	0.41	692	0.47	738	0.54	783	0.63	827	0.71	870	0.79	912	0.88	951	0.96	
2160	578	0.37	623	0.43	679	0.51	731	0.59	775	0.67	817	0.74	857	0.83	896	0.93	935	1.02	974	1.12	
2400	633	0.49	673	0.56	718	0.63	769	0.72	814	0.82	855	0.90	893	0.98	929	1.08	965	1.18	999	1.29	
2640	688	0.64	725	0.71	762	0.79	808	0.87	853	0.98	894	1.09	931	1.17	966	1.26	1000	1.36	1032	1.47	
2880	743	0.81	778	0.90	811	0.98	848	1.06	891	1.16	932	1.28	970	1.40	1004	1.49	1037	1.59	1068	1.69	

External Static Pressure (Inches of Water Gauge)																															
		1.10"		1.20"		1.30"		1.40"		1.50"		1.60"		1.70"		1.80"		1.90"		2.00"											
CFM	RPM	BHP	RPM	BHP	RPM	BHP	RPM	BHP	RPM	BHP	RPM	BHP	RPM	BHP	RPM	BHP	RPM	BHP	RPM	BHP											
		<b>1-hp Standard Motor &amp; Drive</b>										<b>1-hp Standard Motor &amp; High Static Drive Kit (or 2-hp Oversized Motor &amp; Drive)</b>										<b>2-hp Oversized Motor &amp; Drive</b>									
1920	990	1.05	1026	1.14	1062	1.24	1096	1.33	1130	1.43	1160	1.52	1190	1.61	1218	1.71	1247	1.80	1273	1.90											
2160	1010	1.21	1047	1.31	1082	1.40	1116	1.50	1150	1.61	1182	1.71	1211	1.81	1242	1.92	1271	2.03	1298	2.14											
2400	1035	1.39	1070	1.50	1104	1.60	1137	1.70	1168	1.81	1201	1.92	1232	2.03	1261	2.14	1291	2.26	—	—											
2640	1065	1.59	1097	1.71	1129	1.82	1161	1.93	1192	2.05	1223	2.16	1252	2.27	—	—	—	—	—	—											
2880	1099	1.80	1130	1.93	1159	2.05	1188	2.18	1217	2.30	—	—	—	—	—	—	—	—	—	—											
											<b>2-hp Oversized Motor &amp; Field Supplied Drive<sup>(b)</sup></b>																				

**Notes:**

1. For standard evaporator fan speed (rpm), reference the standard motor and sheave/fan speed applicable table in the fan performance section.
2. Data includes pressure drop due to standard filters and wet coils. No accessories or options are included in pressure drop data.
3. To determine static pressure drop due to other options/accessories, refer to the applicable table in the fan performance section.
4. 1-hp fan motor heat (MBh) = 2.829 x fan bhp + .4024. 2-hp fan motor heat (MBh) = 3.000 x fan bhp + .5000.
5. Factory supplied motors, in commercial equipment, are definite purpose motors, specifically designed and tested to operate reliably and continuously at all cataloged conditions. Using the full horsepower range of our fan motors as shown in our tabular data will not result in nuisance tripping or premature motor failure. Our product's warranty will not be affected.
6. For electric heat applications, minimum airflow is set to 320 cfm/ton, unless specified otherwise, values found in electric heat temperature rise table.

<sup>(a)</sup> Field supplied fan sheave AK84 and belt AX36 required.

<sup>(b)</sup> Field supplied fan sheave AK56 and belt AX30 required.



## Evaporator Fan Performance – Standard Efficiency

**Table 51. Belt drive evaporator fan performance – 6 tons standard efficiency with gas heat – YSC072H3,4,W\*L,M low & medium heat downflow airflow**

External Static Pressure (Inches of Water Gauge)																						
		0.10"		0.20"		0.30"		0.40"		0.50"		0.60"		0.70"		0.80"		0.90"		1.00"		
CFM	RPM	BHP	RPM	BHP	RPM	BHP	RPM	BHP	RPM	BHP	RPM	BHP	RPM	BHP	RPM	BHP	RPM	BHP	RPM	BHP	RPM	BHP
1-hp Standard Motor & Field Supplied Low Static Drive <sup>(a)</sup>											1-hp Standard Motor & Drive											
1920	—	—	—	—	597	0.37	652	0.44	700	0.51	745	0.58	788	0.66	829	0.74	869	0.82	906	0.91		
2160	—	—	575	0.38	629	0.46	683	0.54	730	0.62	774	0.70	815	0.78	854	0.86	893	0.95	929	1.04		
2400	561	0.41	615	0.49	664	0.57	714	0.65	762	0.74	805	0.83	844	0.92	882	1.01	918	1.10	954	1.20		
2640	606	0.53	657	0.62	703	0.70	747	0.79	792	0.88	835	0.98	875	1.08	912	1.18	947	1.27	980	1.37		
2880	651	0.67	699	0.77	743	0.85	785	0.94	825	1.05	867	1.15	906	1.26	943	1.37	978	1.47	1010	1.58		
External Static Pressure (Inches of Water Gauge)																						
		1.10"		1.20"		1.30"		1.40"		1.50"		1.60"		1.70"		1.80"		1.90"		2.00"		
CFM	RPM	BHP	RPM	BHP	RPM	BHP	RPM	BHP	RPM	BHP	RPM	BHP	RPM	BHP	RPM	BHP	RPM	BHP	RPM	BHP	RPM	BHP
1-hp Standard Motor & Drive				1-hp Standard Motor & High Static Drive (or 2-hp Oversized Motor & Drive)												2-hp Oversized Motor & Drive						
1920	941	0.99	977	1.07	1009	1.15	1041	1.23	1073	1.32	1103	1.40	1132	1.49	1159	1.57	1187	1.66	1213	1.75		
2160	964	1.13	997	1.23	1031	1.32	1061	1.41	1093	1.50	1123	1.60	1151	1.69	1179	1.78	1207	1.87	1234	1.97		
2400	988	1.29	1020	1.39	1054	1.50	1085	1.60	1114	1.70	1143	1.80	1171	1.90	1200	2.01	1227	2.11	1254	2.21		
2640	1014	1.47	1046	1.58	1077	1.69	1107	1.80	1138	1.91	1166	2.02	1193	2.13	1222	2.25	—	—	—	—		
2880	1042	1.68	1073	1.79	1103	1.90	1132	2.02	1162	2.14	1190	2.26	—	—	—	—	—	—	—	—		

**Notes:**

1. For standard evaporator fan speed (rpm), reference the standard motor and sheave/fan speed applicable table in the fan performance section.
2. Data includes pressure drop due to standard filters and wet coils. No accessories or options are included in pressure drop data.
3. To determine static pressure drop due to other options/accessories, refer to the applicable table in the fan performance section.
4. 1-hp fan motor heat (MBh) = 2.829 x fan bhp + .4024. 2-hp fan motor heat (MBh) = 3.000 x fan bhp + .5000.
5. Factory supplied motors, in commercial equipment, are definite purpose motors, specifically designed and tested to operate reliably and continuously at all cataloged conditions. Using the full horsepower range of our fan motors as shown in our tabular data will not result in nuisance tripping or premature motor failure. Our product's warranty will not be affected.

<sup>(a)</sup> Field supplied fan sheave AK84 and belt AX36 required.

## Evaporator Fan Performance — Standard Efficiency

**Table 52. Belt drive evaporator fan performance – 6 tons standard efficiency with gas heat – YSC072H3,4,W\*L,M low & medium heat horizontal airflow**

External Static Pressure (Inches of Water Gauge)																					
		0.10"		0.20"		0.30"		0.40"		0.50"		0.60"		0.70"		0.80"		0.90"		1.00"	
CFM	RPM	BHP	RPM	BHP	RPM	BHP	RPM	BHP	RPM	BHP	RPM	BHP	RPM	BHP	RPM	BHP	RPM	BHP	RPM	BHP	
<b>1-hp Standard Motor &amp; Field Supplied Low Static Drive<sup>(a)</sup></b>											<b>1-hp Standard Motor &amp; Drive</b>										
1920	—	—	591	0.34	649	0.42	699	0.48	745	0.56	789	0.64	834	0.72	877	0.81	918	0.89	957	0.97	
2160	587	0.38	633	0.44	690	0.52	740	0.61	784	0.68	825	0.76	865	0.85	904	0.95	943	1.04	981	1.13	
2400	643	0.51	682	0.58	732	0.65	781	0.75	825	0.84	864	0.92	902	1.01	938	1.11	974	1.21	1010	1.32	
2640	700	0.66	736	0.74	775	0.81	822	0.90	866	1.01	906	1.11	942	1.20	976	1.29	1009	1.40	1042	1.51	
2880	756	0.84	790	0.93	823	1.01	864	1.09	907	1.20	947	1.32	983	1.43	1017	1.53	1048	1.62	1080	1.73	
External Static Pressure (Inches of Water Gauge)																					
		1.10"		1.20"		1.30"		1.40"		1.50"		1.60"		1.70"		1.80"		1.90"		2.00"	
CFM	RPM	BHP	RPM	BHP	RPM	BHP	RPM	BHP	RPM	BHP	RPM	BHP	RPM	BHP	RPM	BHP	RPM	BHP	RPM	BHP	
<b>1-hp Standard Motor &amp; Drive</b>			<b>1-hp Standard Motor &amp; High Static Drive (or 2-hp Oversized Motor &amp; Drive)</b>						<b>2-hp Oversized Motor &amp; Drive</b>												
1920	996	1.06	1033	1.16	1067	1.25	1102	1.35	1134	1.44	1165	1.53	1195	1.63	1223	1.72	1251	1.82	1277	1.91	
2160	1018	1.23	1054	1.32	1090	1.42	1123	1.52	1156	1.63	1188	1.73	1218	1.84	1247	1.94	1276	2.05	1304	2.16	
2400	1044	1.42	1079	1.52	1112	1.62	1145	1.73	1177	1.83	1208	1.94	1240	2.06	1268	2.17	1298	2.29	—	—	
2640	1075	1.62	1107	1.74	1139	1.85	1170	1.96	1201	2.08	1232	2.19	—	—	—	—	—	—	—	—	
2880	1111	1.85	1140	1.97	1169	2.09	1200	2.22	—	—	—	—	—	—	—	—	—	—	—	—	
<b>2-hp Oversized Motor &amp; Drive &amp; Field Supplied High Static Drive<sup>(b)</sup></b>																					

**Notes:**

1. For standard evaporator fan speed (rpm), reference the standard motor and sheave/fan speed applicable table in the fan performance section.
2. Data includes pressure drop due to standard filters and wet coils. No accessories or options are included in pressure drop data.
3. To determine static pressure drop due to other options/accessories, refer to the applicable table in the fan performance section.
4. 1-hp fan motor heat (MBh) = 2.829 x fan bhp + .4024. 2-hp fan motor heat (MBh) = 3.000 x fan bhp + .5000.
5. Factory supplied motors, in commercial equipment, are definite purpose motors, specifically designed and tested to operate reliably and continuously at all cataloged conditions. Using the full horsepower range of our fan motors as shown in our tabular data will not result in nuisance tripping or premature motor failure. Our product's warranty will not be affected.

<sup>(a)</sup> Field supplied fan sheave AK84 and belt AX36 required.

<sup>(b)</sup> Field supplied fan sheave AK56 and belt AX30 required.



## Evaporator Fan Performance – Standard Efficiency

**Table 53. Belt drive evaporator fan performance – 6 tons standard efficiency with gas heat – YSC072H3,4,W\*H high heat downflow airflow**

External Static Pressure (Inches of Water Gauge)																					
		0.10"		0.20"		0.30"		0.40"		0.50"		0.60"		0.70"		0.80"		0.90"		1.00"	
CFM	RPM	BHP	RPM	BHP	RPM	BHP	RPM	BHP	RPM	BHP	RPM	BHP	RPM	BHP	RPM	BHP	RPM	BHP	RPM	BHP	
1-hp Standard Motor & Field Supplied Low Static Drive <sup>(a)</sup>											1-hp Standard Motor & Drive										
1920	—	—	574	0.34	631	0.41	681	0.48	727	0.55	771	0.63	814	0.71	853	0.79	892	0.87	928	0.95	
2160	562	0.36	616	0.44	671	0.52	719	0.60	763	0.68	805	0.76	845	0.84	884	0.93	921	1.02	957	1.11	
2400	612	0.48	662	0.56	711	0.65	759	0.74	802	0.83	842	0.91	879	1.00	916	1.09	951	1.19	986	1.29	
2640	663	0.63	709	0.71	754	0.80	798	0.90	842	1.00	881	1.10	917	1.19	951	1.29	986	1.39	1018	1.49	
2880	715	0.80	758	0.88	799	0.98	840	1.08	880	1.19	920	1.30	955	1.41	990	1.51	1022	1.62	1053	1.72	
External Static Pressure (Inches of Water Gauge)																					
		1.10"		1.20"		1.30"		1.40"		1.50"		1.60"		1.70"		1.80"		1.90"		2.00"	
CFM	RPM	BHP	RPM	BHP	RPM	BHP	RPM	BHP	RPM	BHP	RPM	BHP	RPM	BHP	RPM	BHP	RPM	BHP	RPM	BHP	
1-hp Standard Motor & Drive				1-hp Standard Motor & High Static Drive (or 2-hp Oversized Motor & Drive)								2-hp Oversized Motor & Drive									
1920	963	1.04	997	1.12	1028	1.20	1061	1.28	1090	1.36	1119	1.45	1149	1.54	1177	1.63	1203	1.71	1229	1.80	
2160	990	1.21	1023	1.30	1055	1.39	1086	1.48	1115	1.57	1144	1.66	1173	1.76	1200	1.85	1227	1.95	1253	2.04	
2400	1019	1.39	1051	1.49	1083	1.60	1113	1.70	1141	1.80	1171	1.90	1199	2.01	1225	2.10	1252	2.20	—	—	
2640	1050	1.59	1081	1.70	1111	1.81	1141	1.93	1170	2.04	1198	2.15	1226	2.27	—	—	—	—	—	—	
2880	1084	1.83	1114	1.94	1143	2.06	1172	2.18	1199	2.30	—	—	—	—	—	—	—	—	—	—	

**Notes:**

1. For standard evaporator fan speed (rpm), reference the standard motor and sheave/fan speed applicable table in the fan performance section.
2. Data includes pressure drop due to standard filters and wet coils. No accessories or options are included in pressure drop data.
3. To determine static pressure drop due to other options/accessories, refer to the applicable table in the fan performance section.
4. 1-hp fan motor heat (MBh) = 2.829 x fan bhp + .4024. 2-hp fan motor heat (MBh) = 3.000 x fan bhp + .5000.
5. Factory supplied motors, in commercial equipment, are definite purpose motors, specifically designed and tested to operate reliably and continuously at all cataloged conditions. Using the full horsepower range of our fan motors as shown in our tabular data will not result in nuisance tripping or premature motor failure. Our product's warranty will not be affected.

<sup>(a)</sup> Field supplied fan sheave AK84 and belt AX36 required.

## Evaporator Fan Performance — Standard Efficiency

**Table 54. Belt drive evaporator fan performance – 6 tons standard efficiency with gas heat – YSC072H3,4,W\*H high heat horizontal airflow**

External Static Pressure (Inches of Water Gauge)																					
		0.10"		0.20"		0.30"		0.40"		0.50"		0.60"		0.70"		0.80"		0.90"		1.00"	
CFM	RPM	BHP	RPM	BHP	RPM	BHP	RPM	BHP	RPM	BHP	RPM	BHP	RPM	BHP	RPM	BHP	RPM	BHP	RPM	BHP	
<b>1-hp Standard Motor &amp; Field Supplied Low Static Drive<sup>(a)</sup></b>											<b>1-hp Standard Motor &amp; Drive</b>										
1920	565	0.31	627	0.39	680	0.46	727	0.52	772	0.61	816	0.69	859	0.77	902	0.86	942	0.94	981	1.03	
2160	621	0.43	677	0.50	729	0.59	774	0.66	816	0.74	856	0.83	895	0.93	934	1.02	973	1.11	1009	1.21	
2400	680	0.57	729	0.65	778	0.74	823	0.84	862	0.92	900	1.00	936	1.10	972	1.20	1006	1.31	1041	1.41	
2640	741	0.75	782	0.82	828	0.92	872	1.03	911	1.13	947	1.21	981	1.31	1014	1.41	1048	1.53	1079	1.64	
2880	802	0.95	837	1.04	880	1.13	921	1.24	960	1.36	995	1.47	1028	1.56	1060	1.66	1091	1.77	1122	1.89	
External Static Pressure (Inches of Water Gauge)																					
		1.10"		1.20"		1.30"		1.40"		1.50"		1.60"		1.70"		1.80"		1.90"		2.00"	
CFM	RPM	BHP	RPM	BHP	RPM	BHP	RPM	BHP	RPM	BHP	RPM	BHP	RPM	BHP	RPM	BHP	RPM	BHP	RPM	BHP	
<b>1-hp Standard Motor &amp; High Static Drive (or 2-hp Oversized Motor &amp; Drive)</b>											<b>2-hp Oversized Motor &amp; Drive</b>										
1920	1018	1.12	1054	1.21	1089	1.31	1122	1.40	1154	1.50	1184	1.59	1212	1.69	1241	1.78	1268	1.88	1293	1.97	
2160	1045	1.30	1081	1.40	1114	1.50	1149	1.61	1181	1.71	1211	1.81	1241	1.92	1270	2.03	1298	2.13	1324	2.24	
2400	1076	1.51	1110	1.62	1143	1.72	1176	1.83	1206	1.94	1238	2.05	1267	2.16	1297	2.28	—	—	—	—	
2640	1111	1.75	1144	1.87	1174	1.98	1205	2.09	1236	2.21	—	—	—	—	—	—	—	—	—	—	
2880	1151	2.02	1180	2.14	1209	2.27	—	—	—	—	—	—	—	—	—	—	—	—	—	—	
											<b>2-hp Oversized Motor &amp; Field Supplied High Static Drive<sup>(b)</sup></b>										

**Notes:**

1. For standard evaporator fan speed (rpm), reference the standard motor and sheave/fan speed applicable table in the fan performance section.
2. Data includes pressure drop due to standard filters and wet coils. No accessories or options are included in pressure drop data.
3. To determine static pressure drop due to other options/accessories, refer to the applicable table in the fan performance section.
4. 1-hp fan motor heat (MBh) = 2.829 x fan bhp + .4024. 2-hp fan motor heat (MBh) = 3.000 x fan bhp + .5000.
5. Factory supplied motors, in commercial equipment, are definite purpose motors, specifically designed and tested to operate reliably and continuously at all cataloged conditions. Using the full horsepower range of our fan motors as shown in our tabular data will not result in nuisance tripping or premature motor failure. Our product's warranty will not be affected.

<sup>(a)</sup> Field supplied fan sheave AK84 and belt AX36 required.

<sup>(b)</sup> Field supplied fan sheave AK56 and belt AX30 required.



## Evaporator Fan Performance – Standard Efficiency

**Table 55. Belt drive evaporator fan performance – 7.5 tons standard efficiency – TSC090H3,4,W downflow airflow**

		External Static Pressure (Inches of Water Gauge)																						
		0.10"		0.20"		0.30"		0.40"		0.50"		0.60"		0.70"		0.80"		0.90"		1.00"				
CFM	RPM	BHP	RPM	BHP	RPM	BHP	RPM	BHP	RPM	BHP	RPM	BHP	RPM	BHP	RPM	BHP	RPM	BHP	RPM	BHP	RPM	BHP		
<b>1-hp Standard Motor &amp; Field Supplied Low Static Drive<sup>(a)</sup></b>											<b>1-hp Standard Motor &amp; Drive</b>													
2400	613	0.42	668	0.50	711	0.57	756	0.65	798	0.72	838	0.80	875	0.88	911	0.96	945	1.04	978	1.12				
2700	676	0.56	733	0.69	767	0.74	808	0.83	848	0.91	886	1.00	922	1.09	956	1.18	989	1.27	1021	1.36				
3000	741	0.75	793	0.89	832	0.98	863	1.04	901	1.14	936	1.24	971	1.33	1003	1.43	1036	1.53	1067	1.63				
3300	807	0.98	849	1.10	897	1.26	925	1.32	954	1.40	989	1.51	1022	1.62	1053	1.73	1084	1.83	1113	1.94				
3600	874	1.25	909	1.36	957	1.55	990	1.67	1015	1.73	1042	1.82	1074	1.95	1104	2.07	1134	2.18	1163	2.30				
		External Static Pressure (Inches of Water Gauge)																						
		1.10"		1.20"		1.30"		1.40"		1.50"		1.60"		1.70"		1.80"		1.90"		2.00"				
CFM	RPM	BHP	RPM	BHP	RPM	BHP	RPM	BHP	RPM	BHP	RPM	BHP	RPM	BHP	RPM	BHP	RPM	BHP	RPM	BHP	RPM	BHP		
<b>1-hp Standard Motor &amp; Drive</b>											<b>3-hp Oversized Motor &amp; Drive</b>													
2400	1011	1.20	1041	1.28	1070	1.36	1099	1.44	1127	1.52	1153	1.60	1178	1.68	1203	1.76	1229	1.84	1252	1.92				
2700	1051	1.45	1082	1.54	1111	1.63	1139	1.72	1166	1.81	1192	1.90	1217	1.98	1243	2.08	1268	2.17	1291	2.25				
3000	1096	1.73	1124	1.83	1153	1.93	1180	2.03	1207	2.13	1233	2.23	1258	2.33	1283	2.43	1308	2.53	1331	2.63				
3300	1142	2.05	1170	2.16	1197	2.27	1223	2.37	1249	2.48	1275	2.59	1300	2.71	1324	2.82	1347	2.92	1371	3.03				
3600	1191	2.41	1218	2.53	1244	2.65	1269	2.77	1294	2.89	1319	3.01	1342	3.12	1366	3.24	1389	3.36	—	—				
											<b>3-hp Oversized Motor &amp; Field Supplied High Static Drive<sup>(b)</sup></b>													

**Notes:**

1. For standard evaporator fan speed (rpm), reference the standard motor and sheave/fan speed applicable table in the fan performance section.
2. Data includes pressure drop due to standard filters and wet coils. No accessories or options are included in pressure drop data.
3. To determine static pressure drop due to other options/accessories, refer to the applicable table in the fan performance section.
4. 1-hp fan motor heat (MBh) = 2.829 x fan bhp + .4024. 2-hp fan motor heat (MBh) = 3.000 x fan bhp + .5000.
5. Factory supplied motors, in commercial equipment, are definite purpose motors, specifically designed and tested to operate reliably and continuously at all cataloged conditions. Using the full horsepower range of our fan motors as shown in our tabular data will not result in nuisance tripping or premature motor failure. Our product's warranty will not be affected.

<sup>(a)</sup> Field supplied fan sheave AK74 and belt AX35 required.

<sup>(b)</sup> Field supplied fan sheave BK52 and belt BX30 required.

## Evaporator Fan Performance — Standard Efficiency

**Table 56. Belt drive evaporator fan performance – 7.5 tons standard efficiency – TSC090H3,4,W horizontal airflow**

External Static Pressure (Inches of Water Gauge)																					
		0.10"		0.20"		0.30"		0.40"		0.50"		0.60"		0.70"		0.80"		0.90"		1.00"	
CFM	RPM	BHP	RPM	BHP	RPM	BHP	RPM	BHP	RPM	BHP	RPM	BHP	RPM	BHP	RPM	BHP	RPM	BHP	RPM	BHP	
<b>1-hp Standard Motor &amp; Field Supplied Low Static Drive</b>											<b>1-hp Standard Motor &amp; Drive</b>										
<b>(a)</b>																					
2400	681	0.52	726	0.60	770	0.69	811	0.77	852	0.85	892	0.94	931	1.02	969	1.11	1007	1.20	1046	1.31	
2700	754	0.72	796	0.81	835	0.90	874	0.99	910	1.08	947	1.18	983	1.27	1018	1.37	1052	1.47	1087	1.57	
3000	828	0.97	868	1.07	903	1.17	938	1.27	973	1.37	1005	1.47	1039	1.57	1072	1.68	1103	1.78	1135	1.90	
3300	904	1.26	940	1.37	974	1.48	1004	1.59	1037	1.71	1069	1.82	1098	1.93	1129	2.04	1159	2.15	1188	2.27	
3600	979	1.62	1013	1.74	1045	1.86	1074	1.98	1103	2.10	1133	2.22	1162	2.35	1189	2.46	1217	2.58	1245	2.71	
<b>External Static Pressure (Inches of Water Gauge)</b>																					
		1.10"		1.20"		1.30"		1.40"		1.50"		1.60"		1.70"		1.80"		1.90"		2.00"	
CFM	RPM	BHP	RPM	BHP	RPM	BHP	RPM	BHP	RPM	BHP	RPM	BHP	RPM	BHP	RPM	BHP	RPM	BHP	RPM	BHP	
<b>3-hp Oversized Motor &amp; Drive</b>																					
2400	1083	1.42	1119	1.52	1153	1.63	1185	1.73	1218	1.84	1249	1.95	1278	2.06	1307	2.16	1337	2.28	1364	2.38	
2700	1120	1.67	1154	1.79	1188	1.91	1220	2.02	1252	2.14	1283	2.26	1313	2.39	1342	2.51	1370	2.63	1397	2.74	
3000	1166	2.00	1197	2.12	1227	2.23	1256	2.34	1288	2.47	1318	2.61	1347	2.73	1377	2.87	1406	3.01	1433	3.14	
3300	1217	2.39	1246	2.51	1274	2.63	1302	2.75	1330	2.88	1357	3.00	1384	3.13	1413	3.27	1441	3.42	—	—	
3600	1272	2.83	1299	2.96	1326	3.09	1352	3.22	1378	3.35	—	—	—	—	—	—	—	—	—	—	
<b>3-hp Oversized Motor &amp; Field Supplied High Static Drive<sup>(b)</sup></b>																					

**Notes:**

1. For standard evaporator fan speed (rpm), reference the standard motor and sheave/fan speed applicable table in the fan performance section.
2. Data includes pressure drop due to standard filters and wet coils. No accessories or options are included in pressure drop data.
3. To determine static pressure drop due to other options/accessories, refer to the applicable table in the fan performance section.
4. 1-hp fan motor heat (MBh) = 2.829 x fan bhp + .4024. 2-hp fan motor heat (MBh) = 3.000 x fan bhp + .5000.
5. Factory supplied motors, in commercial equipment, are definite purpose motors, specifically designed and tested to operate reliably and continuously at all cataloged conditions. Using the full horsepower range of our fan motors as shown in our tabular data will not result in nuisance tripping or premature motor failure. Our product's warranty will not be affected.

<sup>(a)</sup> Field supplied fan sheave AK74 and belt AX35 required.

<sup>(b)</sup> Field supplied fan sheave BK52 and belt BX30 required.



## Evaporator Fan Performance – Standard Efficiency

**Table 57. Belt drive evaporator fan performance – 7.5 tons standard efficiency with gas heat – YSC090H3,4,W low & medium gas heat downflow airflow**

External Static Pressure (Inches of Water Gauge)																					
		0.10"		0.20"		0.30"		0.40"		0.50"		0.60"		0.70"		0.80"		0.90"		1.00"	
CFM	RPM	BHP	RPM	BHP	RPM	BHP	RPM	BHP	RPM	BHP	RPM	BHP	RPM	BHP	RPM	BHP	RPM	BHP	RPM	BHP	
1-hp Standard Motor & Field Supplied Low Static Drive <sup>(a)</sup>											1-hp Standard Motor & Drive										
2400	655	0.47	707	0.55	758	0.64	802	0.72	845	0.80	886	0.88	925	0.97	961	1.05	997	1.14	1028	1.22	
2700	724	0.64	770	0.73	817	0.83	861	0.92	900	1.02	939	1.11	976	1.20	1011	1.30	1045	1.39	1077	1.49	
3000	794	0.86	837	0.96	878	1.06	920	1.17	958	1.27	994	1.38	1029	1.48	1063	1.58	1096	1.69	1128	1.79	
3300	865	1.12	905	1.23	942	1.34	980	1.45	1018	1.57	1053	1.69	1085	1.80	1117	1.92	1148	2.03	1179	2.14	
3600	937	1.43	973	1.55	1008	1.67	1042	1.79	1077	1.91	1112	2.05	1144	2.18	1174	2.30	1203	2.42	1232	2.55	
External Static Pressure (Inches of Water Gauge)																					
		1.10"		1.20"		1.30"		1.40"		1.50"		1.60"		1.70"		1.80"		1.90"		2.00"	
CFM	RPM	BHP	RPM	BHP	RPM	BHP	RPM	BHP	RPM	BHP	RPM	BHP	RPM	BHP	RPM	BHP	RPM	BHP	RPM	BHP	
1-hp Standard Motor & Drive											3-hp Oversized Motor & Drive										
2400	1060	1.30	1091	1.39	1120	1.48	1150	1.57	1178	1.65	1204	1.74	1231	1.83	1256	1.91	1281	2.00	1304	2.09	
2700	1109	1.58	1139	1.68	1167	1.77	1195	1.86	1223	1.96	1249	2.06	1275	2.16	1301	2.26	1325	2.35	1349	2.45	
3000	1158	1.90	1188	2.00	1216	2.11	1244	2.21	1271	2.32	1296	2.42	1321	2.53	1346	2.64	1371	2.75	1393	2.85	
3300	1209	2.26	1238	2.37	1265	2.49	1293	2.61	1319	2.72	1344	2.84	1369	2.95	1393	3.07	1416	3.18	1441	3.30	
3600	1261	2.67	1289	2.80	1316	2.92	1342	3.04	1368	3.17	1393	3.30	1419	3.43	—	—	—	—	—	—	
											3-hp Oversized Motor & Field Supplied High Static Drive <sup>(b)</sup>										

**Notes:**

- For standard evaporator fan speed (rpm), reference the standard motor and sheave/fan speed applicable table in the fan performance section.
- Data includes pressure drop due to standard filters and wet coils. No accessories or options are included in pressure drop data.
- To determine static pressure drop due to other options/accessories, refer to the applicable table in the fan performance section.
- 1-hp fan motor heat (MBh) = 2.829 x Fan bhp + .4024. 3-hp fan motor heat (MBh) = 2.900 x Fan bhp + .4750
- Factory supplied motors, in commercial equipment, are definite purpose motors, specifically designed and tested to operate reliably and continuously at all cataloged conditions. Using the full horsepower range of our fan motors as shown in our tabular data will not result in nuisance tripping or premature motor failure. Our product's warranty will not be affected.

<sup>(a)</sup> Field Supplied Fan Sheave AK74 and Belt AX35

<sup>(b)</sup> Field Supplied Fan Sheave BK52 and Belt BX30



## Evaporator Fan Performance — Standard Efficiency

**Table 58. Belt drive evaporator fan performance – 7.5 tons standard efficiency with gas heat – YSC090H3,4,W low & medium gas heat - horizontal airflow**

External Static Pressure (Inches of Water Gauge)																					
		0.10"		0.20"		0.30"		0.40"		0.50"		0.60"		0.70"		0.80"		0.90"		1.00"	
CFM	RPM	BHP	RPM	BHP	RPM	BHP	RPM	BHP	RPM	BHP	RPM	BHP	RPM	BHP	RPM	BHP	RPM	BHP	RPM	BHP	
1-hp Standard Motor & Field Supplied Low Static Drive <sup>(a)</sup>											1-hp Standard Motor & Drive										
2400	739	0.61	783	0.69	825	0.77	866	0.85	903	0.93	941	1.02	978	1.11	1013	1.20	1046	1.28	1078	1.37	
2700	821	0.85	861	0.94	898	1.03	935	1.12	972	1.21	1005	1.30	1038	1.39	1072	1.49	1104	1.59	1135	1.69	
3000	904	1.14	940	1.24	974	1.34	1008	1.44	1042	1.54	1075	1.65	1105	1.74	1135	1.85	1164	1.95	1195	2.06	
3300	987	1.49	1020	1.60	1052	1.71	1083	1.82	1113	1.93	1144	2.04	1174	2.16	1203	2.27	1230	2.38	1257	2.49	
3600	1071	1.92	1101	2.04	1131	2.15	1160	2.27	1188	2.39	1216	2.51	1244	2.64	1272	2.76	1298	2.88	1323	3.00	
External Static Pressure (Inches of Water Gauge)																					
		1.10"		1.20"		1.30"		1.40"		1.50"		1.60"		1.70"		1.80"		1.90"		2.00"	
CFM	RPM	BHP	RPM	BHP	RPM	BHP	RPM	BHP	RPM	BHP	RPM	BHP	RPM	BHP	RPM	BHP	RPM	BHP	RPM	BHP	
3-hp Oversized Motor & Drive											3-hp Oversized Motor & Field Supplied Drive <sup>(b)</sup>										
2400	1110	1.46	1140	1.55	1169	1.64	1198	1.73	1225	1.82	1251	1.91	1277	2.01	1301	2.10	1326	2.19	1350	2.28	
2700	1165	1.78	1195	1.88	1223	1.98	1251	2.08	1277	2.18	1304	2.29	1330	2.39	1355	2.49	1378	2.59	1402	2.70	
3000	1224	2.17	1252	2.28	1279	2.39	1306	2.49	1332	2.60	1358	2.71	1383	2.83	1407	2.94	1430	3.05	1454	3.16	
3300	1283	2.61	1311	2.73	1338	2.85	1364	2.97	1389	3.09	1413	3.21	1439	3.33	—	—	—	—	—	—	
3600	1349	3.13	1373	3.25	1398	3.38	—	—	—	—	—	—	—	—	—	—	—	—	—	—	

**Notes:**

1. For standard evaporator fan speed (rpm), reference the standard motor and sheave/fan speed applicable table in the fan performance section.
2. Data includes pressure drop due to standard filters and wet coils. No accessories or options are included in pressure drop data.
3. To determine static pressure drop due to other options/accessories, refer to the applicable table in the fan performance section.
4. 1-hp fan motor heat (MBh) = 2.829 x Fan bhp + .4024. 3-hp fan motor heat (MBh) = 2.900 x Fan bhp + .4750
5. Factory supplied motors, in commercial equipment, are definite purpose motors, specifically designed and tested to operate reliably and continuously at all cataloged conditions. Using the full horsepower range of our fan motors as shown in our tabular data will not result in nuisance tripping or premature motor failure. Our product's warranty will not be affected.

<sup>(a)</sup> Field Supplied Fan Sheave AK74 and Belt AX35

<sup>(b)</sup> Field Supplied Fan Sheave BK52 and Belt BX30



## Evaporator Fan Performance – Standard Efficiency

**Table 59. Belt drive evaporator fan performance – 7.5 tons standard efficiency with gas heat – YSC090H3,4,W high gas heat downflow airflow**

External Static Pressure (Inches of Water Gauge)																					
		0.10"		0.20"		0.30"		0.40"		0.50"		0.60"		0.70"		0.80"		0.90"		1.00"	
CFM	RPM	BHP	RPM	BHP	RPM	BHP	RPM	BHP	RPM	BHP	RPM	BHP	RPM	BHP	RPM	BHP	RPM	BHP	RPM	BHP	
1-hp Standard Motor & Field Supplied Low Static Drive <sup>(a)</sup>											1-hp Standard Motor & Drive										
2400	675	0.51	727	0.60	772	0.68	815	0.76	857	0.85	896	0.93	935	1.02	971	1.11	1006	1.19	1041	1.29	
2700	748	0.70	793	0.80	837	0.89	877	0.98	915	1.08	952	1.17	988	1.27	1022	1.37	1056	1.47	1089	1.57	
3000	821	0.94	862	1.04	903	1.15	941	1.25	976	1.35	1011	1.46	1045	1.57	1077	1.67	1109	1.78	1140	1.89	
3300	895	1.23	932	1.34	970	1.46	1007	1.58	1040	1.69	1072	1.79	1104	1.91	1134	2.03	1164	2.15	1194	2.27	
3600	969	1.57	1004	1.70	1038	1.82	1073	1.95	1106	2.07	1136	2.19	1166	2.32	1195	2.44	1223	2.57	1251	2.70	
External Static Pressure (Inches of Water Gauge)																					
		1.10"		1.20"		1.30"		1.40"		1.50"		1.60"		1.70"		1.80"		1.90"		2.00"	
CFM	RPM	BHP	RPM	BHP	RPM	BHP	RPM	BHP	RPM	BHP	RPM	BHP	RPM	BHP	RPM	BHP	RPM	BHP	RPM	BHP	
3-hp Oversized Motor & Drive											3-hp Oversized Motor & Field Supplied High Static Drive <sup>(b)</sup>										
2400	1074	1.37	1105	1.46	1136	1.55	1165	1.64	1194	1.73	1222	1.83	1250	1.92	1275	2.00	1301	2.10	1326	2.18	
2700	1121	1.66	1151	1.76	1181	1.86	1211	1.97	1238	2.06	1266	2.17	1292	2.27	1318	2.37	1344	2.47	1369	2.57	
3000	1170	2.00	1199	2.11	1229	2.22	1256	2.33	1285	2.44	1311	2.55	1336	2.66	1363	2.77	1388	2.89	1413	3.00	
3300	1223	2.39	1251	2.50	1279	2.62	1305	2.74	1333	2.87	1358	2.98	1384	3.11	1408	3.23	1434	3.35	—	—	
3600	1279	2.83	1305	2.95	1331	3.08	1357	3.21	1383	3.34	—	—	—	—	—	—	—	—	—	—	

**Notes:**

1. For standard evaporator fan speed (rpm), reference the standard motor and sheave/fan speed applicable table in the fan performance section.
2. Data includes pressure drop due to standard filters and wet coils. No accessories or options are included in pressure drop data.
3. To determine static pressure drop due to other options/accessories, refer to the applicable table in the fan performance section.
4. 1-hp fan motor heat (MBh) = 2.829 x Fan bhp + .4024. 3-hp fan motor heat (MBh) = 2.900 x Fan bhp + .4750
5. Factory supplied motors, in commercial equipment, are definite purpose motors, specifically designed and tested to operate reliably and continuously at all cataloged conditions. Using the full horsepower range of our fan motors as shown in our tabular data will not result in nuisance tripping or premature motor failure. Our product's warranty will not be affected.

<sup>(a)</sup> Field Supplied Fan Sheave AK74 and Belt AX35

<sup>(b)</sup> Field Supplied Fan Sheave BK52 and Belt BX30

## Evaporator Fan Performance — Standard Efficiency

**Table 60. Belt drive evaporator fan performance – 7.5 tons standard efficiency with gas heat – YSC090H3,4,W high gas heat horizontal airflow**

External Static Pressure (Inches of Water Gauge)																					
		0.10"		0.20"		0.30"		0.40"		0.50"		0.60"		0.70"		0.80"		0.90"		1.00"	
CFM	RPM	BHP	RPM	BHP	RPM	BHP	RPM	BHP	RPM	BHP	RPM	BHP	RPM	BHP	RPM	BHP	RPM	BHP	RPM	BHP	
1-hp Standard Motor & Field Supplied Low Static Drive <sup>(a)</sup>											1-hp Standard Motor & Drive										
2400	776	0.70	819	0.79	859	0.87	898	0.96	936	1.05	972	1.13	1007	1.22	1039	1.31	1071	1.40	1102	1.49	
2700	863	0.97	901	1.07	938	1.16	974	1.26	1009	1.36	1043	1.46	1075	1.55	1106	1.65	1136	1.75	1165	1.85	
3000	951	1.31	985	1.42	1019	1.52	1052	1.63	1084	1.73	1116	1.84	1146	1.95	1176	2.06	1205	2.17	1232	2.28	
3300	1039	1.72	1071	1.84	1102	1.95	1132	2.07	1162	2.18	1191	2.30	1220	2.42	1248	2.54	1275	2.66	1302	2.78	
3600	1128	2.21	1157	2.34	1186	2.46	1214	2.59	1242	2.71	1269	2.84	1296	2.97	1322	3.10	1348	3.23	1373	3.36	
External Static Pressure (Inches of Water Gauge)																					
		1.10"		1.20"		1.30"		1.40"		1.50"		1.60"		1.70"		1.80"		1.90"		2.00"	
CFM	RPM	BHP	RPM	BHP	RPM	BHP	RPM	BHP	RPM	BHP	RPM	BHP	RPM	BHP	RPM	BHP	RPM	BHP	RPM	BHP	
3-hp Oversized Motor & Drive											3-hp Oversized Motor & Field Supplied High Static Drive <sup>(b)</sup>										
2400	1132	1.58	1161	1.68	1189	1.77	1216	1.86	1242	1.95	1268	2.04	1293	2.13	1318	2.23	1342	2.33	1364	2.42	
2700	1194	1.95	1222	2.05	1249	2.16	1276	2.26	1301	2.37	1327	2.48	1350	2.57	1374	2.68	1398	2.78	1421	2.88	
3000	1260	2.39	1286	2.50	1312	2.61	1337	2.72	1363	2.84	1387	2.96	1410	3.07	1434	3.19	1457	3.31	—	—	
3300	1328	2.90	1353	3.02	1378	3.14	1402	3.26	1426	3.39	—	—	—	—	—	—	—	—	—	—	
3600	—	—	—	—	—	—	—	—	—	—	—	—	—	—	—	—	—	—	—	—	

**Notes:**

1. For standard evaporator fan speed (rpm), reference the standard motor and sheave/fan speed applicable table in the fan performance section.
2. Data includes pressure drop due to standard filters and wet coils. No accessories or options are included in pressure drop data.
3. To determine static pressure drop due to other options/accessories, refer to the applicable table in the fan performance section.
4. 1-hp fan motor heat (MBh) = 2.829 x Fan bhp + .4024. 3-hp fan motor heat (MBh) = 2.900 x Fan bhp + .4750
5. Factory supplied motors, in commercial equipment, are definite purpose motors, specifically designed and tested to operate reliably and continuously at all cataloged conditions. Using the full horsepower range of our fan motors as shown in our tabular data will not result in nuisance tripping or premature motor failure. Our product's warranty will not be affected.

<sup>(a)</sup> Field Supplied Fan Sheave AK74 and Belt AX35

<sup>(b)</sup> Field Supplied Fan Sheave BK52 and Belt BX30



## Evaporator Fan Performance – Standard Efficiency

**Table 61. Belt drive evaporator fan performance – 7.5 tons standard efficiency – TSC092H3,4,W downflow airflow**

External Static Pressure (Inches of Water Gauge)																					
		0.10"		0.20"		0.30"		0.40"		0.50"		0.60"		0.70"		0.80"		0.90"		1.00"	
CFM	RPM	BHP	RPM	BHP	RPM	BHP	RPM	BHP	RPM	BHP	RPM	BHP	RPM	BHP	RPM	BHP	RPM	BHP	RPM	BHP	
1-hp Standard Motor & Field Supplied Low Static Drive <sup>(a)</sup>											1-hp Standard Motor & Drive										
2400	—	—	474	0.36	524	0.44	570	0.52	611	0.59	650	0.68	686	0.76	720	0.84	752	0.93	783	1.02	
2700	458	0.39	508	0.47	554	0.55	598	0.64	638	0.73	676	0.82	711	0.91	745	1.00	776	1.09	806	1.19	
3000	498	0.52	544	0.60	587	0.69	628	0.78	666	0.88	704	0.98	738	1.08	770	1.18	801	1.28	831	1.38	
3300	539	0.67	581	0.76	621	0.85	660	0.96	696	1.06	732	1.17	766	1.28	797	1.39	828	1.49	856	1.60	
3600	580	0.85	620	0.95	657	1.05	693	1.16	728	1.27	761	1.38	794	1.50	825	1.62	855	1.74	882	1.85	
External Static Pressure (Inches of Water Gauge)																					
		1.10"		1.20"		1.30"		1.40"		1.50"		1.60"		1.70"		1.80"		1.90"		2.00"	
CFM	RPM	BHP	RPM	BHP	RPM	BHP	RPM	BHP	RPM	BHP	RPM	BHP	RPM	BHP	RPM	BHP	RPM	BHP	RPM	BHP	
1-hp Standard Motor & Drive											3-hp Oversized Motor & Drive <sup>(b)</sup>										
2400	813	1.10	841	1.19	868	1.28	894	1.37	920	1.46	943	1.54	967	1.63	990	1.72	1012	1.81	1035	1.90	
2700	836	1.29	864	1.39	891	1.48	917	1.58	942	1.68	966	1.78	990	1.88	1012	1.97	1035	2.07	1056	2.17	
3000	860	1.49	887	1.60	914	1.70	940	1.81	964	1.92	988	2.03	1012	2.13	1035	2.24	1056	2.35	1079	2.46	
3300	885	1.72	911	1.83	938	1.94	963	2.06	988	2.18	1012	2.30	1035	2.42	1057	2.54	1079	2.65	1100	2.77	
3600	910	1.97	937	2.09	963	2.22	988	2.34	1012	2.46	1035	2.59	1059	2.72	1081	2.85	1104	2.98	1124	3.11	
3-hp Oversized Motor & Field Supplied High Static Drive <sup>(c)</sup>																					

**Notes:**

1. For standard evaporator fan speed (rpm), reference the standard motor and sheave/fan speed applicable table in the fan performance section.
2. Data includes pressure drop due to standard filters and wet coils. No accessories or options are included in pressure drop data.
3. To determine static pressure drop due to other options/accessories, refer to the applicable table in the fan performance section.
4. 1-hp fan motor heat (MBh) = 2.829 x fan bhp + .4024. 3-hp fan motor heat (MBh) = 2.900 x Fan bhp - .3800
5. Factory supplied motors, in commercial equipment, are definite purpose motors, specifically designed and tested to operate reliably and continuously at all cataloged conditions. Using the full horsepower range of our fan motors as shown in our tabular data will not result in nuisance tripping or premature motor failure. Our product's warranty will not be affected.

<sup>(a)</sup> BAYLSDR009A

<sup>(b)</sup> BAYHSMT400A

<sup>(c)</sup> Field Supplied AK56 x 1" Fan Sheave

## Evaporator Fan Performance — Standard Efficiency

**Table 62. Direct drive evaporator fan performance – 7.5 tons standard efficiency Title 24 single zone VAV – TSC092H3,4,W downflow airflow**

External Static Pressure (Inches of Water Gauge)																						
		0.10"		0.20"		0.30"		0.40"		0.50"		0.60"		0.70"		0.80"		0.90"		1.00"		
CFM	RPM	BHP	RPM	BHP	RPM	BHP	RPM	BHP	RPM	BHP	RPM	BHP	RPM	BHP	RPM	BHP	RPM	BHP	RPM	BHP	RPM	BHP
2400	713	0.21	763	0.26	807	0.32	851	0.39	892	0.45	924	0.50	957	0.56	991	0.62	1024	0.68	1054	0.74		
2700	792	0.28	834	0.34	880	0.41	914	0.47	955	0.54	992	0.62	1023	0.68	1051	0.74	1081	0.81	1112	0.88		
3000	871	0.36	908	0.43	949	0.51	987	0.58	1018	0.65	1054	0.73	1090	0.81	1120	0.89	1145	0.96	1171	1.02- c		
3300	950	0.47	985	0.54	1020	0.62	1058	0.71	1090	0.79	1118	0.86	1151	0.95	1184	1.04	1214	1.13	1240	1.21		
3600	1030	0.60	1062	0.67	1094	0.76	1128	0.84	1162	0.94	1191	1.03	1216	1.10	1245	1.20	1276	1.30	1305	1.40		
External Static Pressure (Inches of Water Gauge)																						
		1.10"		1.20"		1.30"		1.40"		1.50"		1.60"		1.70"		1.80"		1.90"		2.00"		
CFM	RPM	BHP	RPM	BHP	RPM	BHP	RPM	BHP	RPM	BHP	RPM	BHP	RPM	BHP	RPM	BHP	RPM	BHP	RPM	BHP	RPM	BHP
2400	1084	0.79	1113	0.85	1141	0.90	1168	0.95	1194	1.00	1218	1.05	1243	1.10	1267	1.14	1290	1.19	1314	1.23		
2700	1140	0.94	1169	1.01	1195	1.07	1222	1.13	1248	1.20	1273	1.25	1296	1.31	1321	1.37	1343	1.43	1366	1.48		
3000	1198	1.10	1225	1.18	1252	1.25	1278	1.32	1303	1.40	1328	1.47	1351	1.54	1375	1.61	1398	1.67	1419	1.74		
3300	1262	1.28	1285	1.35	1309	1.43	1335	1.52	1360	1.60	1384	1.69	1407	1.77	1429	1.84	1452	1.92	1475	2.00		
3600	1331	1.49	1355	1.58	1375	1.65	1396	1.74	1418	1.82	1441	1.91	1464	2.01	1487	2.10	1509	2.19	1530	2.27		

**Notes:**

1. For direct drive fan speed (rpm), reference the applicable table in the fan performance section.
2. Data includes pressure drop due to standard filters and wet coils. No accessories or options are included in pressure drop data.
3. To determine static pressure drop due to other options/accessories, refer to the applicable table in the fan performance section.
4. Direct drive fan motor heat (MBh) = 2.7912 x fan bhp + 0.1388
5. Factory supplied motors, in commercial equipment, are definite purpose motors, specifically designed and tested to operate reliably and continuously at all cataloged conditions. Using the full horsepower range of our fan motors as shown in our tabular data will not result in nuisance tripping or premature motor failure. Our product's warranty will not be affected.



## Evaporator Fan Performance – Standard Efficiency

**Table 63. Belt drive evaporator fan performance – 7.5 tons standard efficiency – TSC092H3,4,W horizontal airflow**

External Static Pressure (Inches of Water Gauge)																						
		0.10"		0.20"		0.30"		0.40"		0.50"		0.60"		0.70"		0.80"		0.90"		1.00"		
CFM	RPM	BHP	RPM	BHP	RPM	BHP	RPM	BHP	RPM	BHP	RPM	BHP	RPM	BHP	RPM	BHP	RPM	BHP	RPM	BHP	RPM	BHP
<b>1-hp Standard Motor &amp; Field Supplied Low Static Drive<sup>(a)</sup></b>											<b>1-hp Standard Motor &amp; Drive</b>											
2400	478	0.36	528	0.43	576	0.52	626	0.62	681	0.75	731	0.88	778	1.02	821	1.15	862	1.29	901	1.43		
2700	526	0.49	570	0.57	614	0.66	656	0.76	701	0.88	751	1.02	797	1.17	840	1.32	880	1.47	920	1.63		
3000	575	0.65	615	0.74	655	0.84	694	0.94	731	1.05	770	1.17	817	1.34	859	1.50	900	1.67	938	1.83		
3300	624	0.84	661	0.94	698	1.04	734	1.15	768	1.27	802	1.39	838	1.52	878	1.69	919	1.87	957	2.05		
3600	675	1.07	709	1.17	742	1.28	776	1.41	809	1.53	840	1.65	871	1.79	903	1.92	939	2.10	977	2.29		
External Static Pressure (Inches of Water Gauge)																						
		1.10"		1.20"		1.30"		1.40"		1.50"		1.60"		1.70"		1.80"		1.90"		2.00"		
CFM	RPM	BHP	RPM	BHP	RPM	BHP	RPM	BHP	RPM	BHP	RPM	BHP	RPM	BHP	RPM	BHP	RPM	BHP	RPM	BHP	RPM	BHP
<b>3-hp Oversized Motor &amp; Drive<sup>(b)</sup></b>											<b>3-hp Oversized Motor &amp; Field Supplied High Static Drive<sup>(c)</sup></b>											
2400	938	1.57	973	1.71	1007	1.86	1038	1.99	1070	2.14	1101	2.29	1130	2.44	1159	2.59	1187	2.74	1214	2.89		
2700	956	1.78	991	1.93	1024	2.08	1057	2.25	1088	2.40	1119	2.56	1149	2.73	1177	2.89	1206	3.06	1233	3.22		
3000	975	2.00	1009	2.16	1044	2.34	1075	2.51	1108	2.69	1138	2.86	1167	3.03	1195	3.21	1222	3.38	—	—		
3300	994	2.24	1028	2.42	1063	2.61	1094	2.79	1126	2.98	1155	3.16	1185	3.35	—	—	—	—	—	—		
3600	1013	2.49	1048	2.69	1081	2.88	1114	3.09	1145	3.29	—	—	—	—	—	—	—	—	—	—		

**Notes:**

- For standard evaporator fan speed (rpm), reference the standard motor and sheave/fan speed applicable table in the fan performance section.
- Data includes pressure drop due to standard filters and wet coils. No accessories or options are included in pressure drop data.
- To determine static pressure drop due to other options/accessories, refer to the applicable table in the fan performance section.
- 1-hp fan motor heat (MBh) = 2.829 x fan bhp + .4024. 3-hp fan motor heat (MBh) = 2.900 x Fan bhp - .3800
- Factory supplied motors, in commercial equipment, are definite purpose motors, specifically designed and tested to operate reliably and continuously at all cataloged conditions. Using the full horsepower range of our fan motors as shown in our tabular data will not result in nuisance tripping or premature motor failure. Our product's warranty will not be affected.

<sup>(a)</sup> BAYLSDR009A

<sup>(b)</sup> BAYHSMT400A

<sup>(c)</sup> Field Supplied AK56 x 1" Fan Sheave

## Evaporator Fan Performance — Standard Efficiency

**Table 64. Direct drive evaporator fan performance — 7.5 tons standard efficiency Title 24 single zone VAV — TSC092H3,4,W horizontal airflow**

External Static Pressure (Inches of Water Gauge)																						
		0.10"		0.20"		0.30"		0.40"		0.50"		0.60"		0.70"		0.80"		0.90"		1.00"		
CFM	RPM	BHP	RPM	BHP	RPM	BHP	RPM	BHP	RPM	BHP	RPM	BHP	RPM	BHP	RPM	BHP	RPM	BHP	RPM	BHP	RPM	BHP
2400	720	0.21	769	0.27	817	0.33	856	0.39	894	0.44	929	0.50	964	0.56	997	0.62	1028	0.69	1060	0.75		
2700	800	0.29	841	0.34	888	0.42	927	0.48	962	0.55	995	0.61	1027	0.67	1058	0.74	1088	0.81	1118	0.88		
3000	880	0.38	917	0.44	956	0.51	999	0.59	1032	0.67	1063	0.74	1094	0.81	1123	0.88	1151	0.95	1178	1.02		
3300	961	0.49	994	0.55	1028	0.63	1067	0.72	1104	0.80	1133	0.88	1162	0.96	1190	1.04	1218	1.12	1243	1.19		
3600	1042	0.62	1073	0.69	1104	0.77	1136	0.85	1173	0.95	1205	1.05	1233	1.13	1259	1.22	1285	1.30	1310	1.39		
External Static Pressure (Inches of Water Gauge)																						
		1.10"		1.20"		1.30"		1.40"		1.50"		1.60"		1.70"		1.80"		1.90"		2.00"		
CFM	RPM	BHP	RPM	BHP	RPM	BHP	RPM	BHP	RPM	BHP	RPM	BHP	RPM	BHP	RPM	BHP	RPM	BHP	RPM	BHP	RPM	BHP
2400	1090	0.82	1119	0.89	1147	0.96	1174	1.03	1200	1.10	1226	1.18	1251	1.25	1276	1.33	1299	1.41	1323	1.49		
2700	1147	0.95	1175	1.02	1202	1.10	1228	1.17	1254	1.25	1279	1.33	1304	1.41	1327	1.49	1350	1.57	1374	1.66		
3000	1206	1.10	1233	1.18	1259	1.26	1285	1.34	1309	1.42	1333	1.50	1359	1.59	1381	1.67	1405	1.76	1427	1.85		
3300	1269	1.27	1294	1.35	1320	1.44	1344	1.52	1367	1.61	1391	1.70	1414	1.78	1438	1.88	1460	1.97	1482	2.06		
3600	1335	1.48	1359	1.56	1382	1.64	1405	1.73	1428	1.82	1451	1.91	1473	2.01	1496	2.10	1518	2.20	1538	2.29		

**Notes:**

1. For direct drive evaporator fan speed (rpm), refer to the applicable table in the fan performance section.
2. Data includes pressure drop due to standard filters and wet coils.
3. To determine static pressure drop due to other options/accessories, refer to the applicable table in the fan performance section.
4. Direct drive fan motor heat (MBh) = 2.7912 x fan bhp + 0.1388
5. Factory supplied motors, in commercial equipment, are definite purpose motors, specifically designed and tested to operate reliably and continuously at all cataloged conditions. Using the full horsepower range of our fan motors as shown in our tabular data will not result in nuisance tripping or premature motor failure. Our product's warranty will not be affected.



## Evaporator Fan Performance – Standard Efficiency

**Table 65. Belt drive evaporator fan performance – 7.5 tons standard efficiency with gas heat – YSC092H3,4,W low & medium heat downflow airflow**

External Static Pressure (Inches of Water Gauge)																					
		0.10"		0.20"		0.30"		0.40"		0.50"		0.60"		0.70"		0.80"		0.90"		1.00"	
CFM	RPM	BHP	RPM	BHP	RPM	BHP	RPM	BHP	RPM	BHP	RPM	BHP	RPM	BHP	RPM	BHP	RPM	BHP	RPM	BHP	
1-hp Standard Motor & Field Supplied Low Static Drive <sup>(a)</sup>											1-hp Standard Motor & Drive										
2400	—	—	500	0.39	549	0.47	594	0.55	636	0.63	674	0.71	709	0.80	742	0.88	772	0.96	800	1.04	
2700	493	0.44	533	0.50	584	0.60	626	0.69	666	0.78	704	0.87	739	0.96	772	1.05	802	1.15	830	1.24	
3000	536	0.58	575	0.65	620	0.75	661	0.86	698	0.95	734	1.05	769	1.15	802	1.25	832	1.35	861	1.46	
3300	580	0.75	620	0.84	653	0.91	696	1.05	732	1.16	766	1.26	799	1.37	831	1.48	862	1.59	891	1.70	
3600	625	0.96	665	1.07	693	1.13	730	1.25	768	1.39	800	1.51	832	1.62	861	1.74	891	1.86	920	1.98	
External Static Pressure (Inches of Water Gauge)																					
		1.10"		1.20"		1.30"		1.40"		1.50"		1.60"		1.70"		1.80"		1.90"		2.00"	
CFM	RPM	BHP	RPM	BHP	RPM	BHP	RPM	BHP	RPM	BHP	RPM	BHP	RPM	BHP	RPM	BHP	RPM	BHP	RPM	BHP	
1-hp Standard Motor & Drive											3-hp Oversized Motor & Drive <sup>(b)</sup>										
2400	828	1.12	855	1.20	881	1.29	905	1.37	928	1.45	952	1.53	974	1.61	996	1.69	1017	1.77	1038	1.86	
2700	858	1.33	884	1.42	909	1.51	933	1.60	957	1.69	980	1.79	1002	1.88	1024	1.97	1044	2.06	1066	2.15	
3000	888	1.56	913	1.66	939	1.77	963	1.87	986	1.97	1008	2.07	1032	2.17	1053	2.27	1073	2.37	1093	2.47	
3300	918	1.82	944	1.93	969	2.04	994	2.16	1016	2.26	1039	2.38	1061	2.49	1082	2.60	1103	2.71	1123	2.83	
3600	948	2.10	974	2.22	1000	2.35	1024	2.47	1046	2.59	1069	2.72	1091	2.84	1112	2.96	1133	3.08	1152	3.20	
											3-hp Oversized Motor & Field Supplied High Static Drive <sup>(c)</sup>										

**Notes:**

- For standard evaporator fan speed (rpm), reference the standard motor and sheave/fan speed applicable table in the fan performance section.
- Data includes pressure drop due to standard filters and wet coils. No accessories or options are included in pressure drop data.
- To determine static pressure drop due to other options/accessories, refer to the applicable table in the fan performance section.
- 1-hp fan motor heat (MBh) = 2.829 x fan bhp + .4024. 3-hp fan motor heat (MBh) = 2.900 x Fan bhp - .3800
- Factory supplied motors, in commercial equipment, are definite purpose motors, specifically designed and tested to operate reliably and continuously at all cataloged conditions. Using the full horsepower range of our fan motors as shown in our tabular data will not result in nuisance tripping or premature motor failure. Our product's warranty will not be affected.

<sup>(a)</sup> BAYLSDR009A

<sup>(b)</sup> BAYHSMT400A

<sup>(c)</sup> Field Supplied AK56 x 1" Fan Sheave



## Evaporator Fan Performance — Standard Efficiency

**Table 66. Direct drive evaporator fan performance – 7.5 tons standard efficiency Title 24 single zone VAV with gas heat – YSC092H3,4,W low & medium heat downflow airflow**

External Static Pressure (Inches of Water Gauge)																						
		0.10"		0.20"		0.30"		0.40"		0.50"		0.60"		0.70"		0.80"		0.90"		1.00"		
CFM	RPM	BHP	RPM	BHP	RPM	BHP	RPM	BHP	RPM	BHP	RPM	BHP	RPM	BHP	RPM	BHP	RPM	BHP	RPM	BHP	RPM	BHP
2400	724	0.21	770	0.27	814	0.33	856	0.39	899	0.46	933	0.51	968	0.57	1004	0.64	1039	0.71	1071	0.78		
2700	803	0.29	845	0.35	885	0.41	923	0.48	961	0.55	999	0.63	1033	0.69	1062	0.76	1094	0.83	1126	0.90		
3000	883	0.38	922	0.45	958	0.52	993	0.59	1027	0.67	1061	0.74	1096	0.83	1130	0.91	1157	0.98	1183	1.05		
3300	964	0.49	1000	0.56	1033	0.64	1065	0.72	1097	0.80	1129	0.88	1160	0.97	1191	1.06	1222	1.15	1251	1.23		
3600	1046	0.62	1078	0.70	1110	0.79	1140	0.87	1169	0.95	1198	1.04	1227	1.13	1256	1.23	1284	1.32	1313	1.42		
External Static Pressure (Inches of Water Gauge)																						
		1.10"		1.20"		1.30"		1.40"		1.50"		1.60"		1.70"		1.80"		1.90"		2.00"		
CFM	RPM	BHP	RPM	BHP	RPM	BHP	RPM	BHP	RPM	BHP	RPM	BHP	RPM	BHP	RPM	BHP	RPM	BHP	RPM	BHP	RPM	BHP
2400	1102	0.85	1132	0.92	1161	0.99	1189	1.07	1216	1.14	1242	1.22	1269	1.30	1293	1.38	1318	1.46	1341	1.54		
2700	1156	0.98	1186	1.06	1214	1.14	1241	1.21	1269	1.30	1295	1.38	1319	1.46	1344	1.54	1368	1.63	1393	1.72		
3000	1213	1.13	1241	1.21	1269	1.29	1296	1.38	1322	1.47	1348	1.55	1373	1.64	1397	1.73	1420	1.82	1444	1.91		
3300	1276	1.31	1299	1.39	1325	1.47	1351	1.56	1377	1.66	1403	1.75	1427	1.84	1451	1.94	1475	2.03	1498	2.13		
3600	1342	1.52	1368	1.61	1390	1.69	1412	1.78	1433	1.86	1458	1.96	1482	2.06	1506	2.16	1529	2.27	1551	2.36		

**Notes:**

1. For direct drive evaporator fan speed (rpm), refer to the applicable table in the fan performance section.
2. Data includes pressure drop due to standard filters and wet coils.
3. To determine static pressure drop due to other options/accessories, refer to the applicable table in the fan performance section.
4. Direct drive fan motor heat (MBh) = 2.7912 x fan bhp + 0.1388
5. Factory supplied motors, in commercial equipment, are definite purpose motors, specifically designed and tested to operate reliably and continuously at all cataloged conditions. Using the full horsepower range of our fan motors as shown in our tabular data will not result in nuisance tripping or premature motor failure. Our product's warranty will not be affected.



## Evaporator Fan Performance – Standard Efficiency

**Table 67. Belt drive evaporator fan performance – 7.5 tons standard efficiency with gas heat – YSC092H3,4,W low & medium heat horizontal airflow**

External Static Pressure (Inches of Water Gauge)																					
		0.10"		0.20"		0.30"		0.40"		0.50"		0.60"		0.70"		0.80"		0.90"		1.00"	
CFM	RPM	BHP	RPM	BHP	RPM	BHP	RPM	BHP	RPM	BHP	RPM	BHP	RPM	BHP	RPM	BHP	RPM	BHP	RPM	BHP	
1-hp Standard Motor & Field Supplied Low Static Drive <sup>(a)</sup>											1-hp Standard Motor & Drive										
2400	527	0.43	573	0.51	615	0.59	656	0.68	693	0.77	728	0.86	760	0.95	791	1.04	819	1.13	847	1.22	
2700	581	0.59	624	0.68	663	0.77	699	0.86	736	0.96	770	1.07	801	1.17	830	1.27	859	1.37	886	1.47	
3000	636	0.78	675	0.88	712	0.98	747	1.09	779	1.19	812	1.30	843	1.42	872	1.53	899	1.64	926	1.75	
3300	692	1.02	728	1.13	763	1.24	795	1.35	827	1.47	856	1.58	886	1.70	915	1.83	942	1.95	968	2.08	
3600	748	1.30	782	1.42	814	1.54	845	1.66	874	1.78	903	1.91	929	2.04	957	2.17	985	2.30	1010	2.44	
External Static Pressure (Inches of Water Gauge)																					
		1.10"		1.20"		1.30"		1.40"		1.50"		1.60"		1.70"		1.80"		1.90"		2.00"	
CFM	RPM	BHP	RPM	BHP	RPM	BHP	RPM	BHP	RPM	BHP	RPM	BHP	RPM	BHP	RPM	BHP	RPM	BHP	RPM	BHP	
1-hp Standard Motor & Drive											3-hp Oversized Motor & Drive <sup>(b)</sup>										
2400	873	1.31	899	1.40	923	1.48	946	1.57	969	1.66	992	1.75	1013	1.84	1034	1.93	1054	2.02	1074	2.11	
2700	912	1.57	937	1.67	961	1.77	984	1.87	1007	1.97	1028	2.07	1050	2.17	1071	2.27	1090	2.36	1110	2.47	
3000	951	1.86	976	1.97	1000	2.09	1023	2.20	1045	2.31	1067	2.42	1088	2.53	1107	2.64	1128	2.75	1147	2.86	
3300	992	2.20	1016	2.32	1040	2.44	1062	2.57	1084	2.68	1105	2.81	1126	2.93	1147	3.06	1166	3.17	1186	3.30	
3600	1034	2.57	1057	2.70	1081	2.84	1103	2.98	1124	3.11	1145	3.24	1165	3.37	—	—	—	—	—	—	
											3-hp Oversized Motor & Field Supplied High Static Drive <sup>(c)</sup>										

**Notes:**

- For standard evaporator fan speed (rpm), reference the standard motor and sheave/fan speed applicable table in the fan performance section.
- Data includes pressure drop due to standard filters and wet coils. No accessories or options are included in pressure drop data.
- To determine static pressure drop due to other options/accessories, refer to the applicable table in the fan performance section.
- 1-hp fan motor heat (MBh) = 2.829 x fan bhp + .4024. 3-hp fan motor heat (MBh) = 2.900 x Fan bhp - .3800
- Factory supplied motors, in commercial equipment, are definite purpose motors, specifically designed and tested to operate reliably and continuously at all cataloged conditions. Using the full horsepower range of our fan motors as shown in our tabular data will not result in nuisance tripping or premature motor failure. Our product's warranty will not be affected.

<sup>(a)</sup> BAYLSDR009A

<sup>(b)</sup> BAYHSMT400A

<sup>(c)</sup> Field Supplied AK56 x 1" Fan Sheave

## Evaporator Fan Performance — Standard Efficiency

**Table 68. Direct drive evaporator fan performance – 7.5 tons standard efficiency Title 24 single zone VAV – YSC092H3,4,W low & medium gas heat horizontal airflow**

External Static Pressure (Inches of Water Gauge)																					
		0.10"		0.20"		0.30"		0.40"		0.50"		0.60"		0.70"		0.80"		0.90"		1.00"	
CFM	RPM	BHP	RPM	BHP	RPM	BHP	RPM	BHP	RPM	BHP	RPM	BHP	RPM	BHP	RPM	BHP	RPM	BHP	RPM	BHP	
2400	719	0.21	770	0.27	814	0.33	855	0.39	895	0.45	931	0.51	965	0.57	997	0.63	1027	0.68	1056	0.73	
2700	797	0.28	843	0.35	886	0.41	923	0.48	959	0.55	996	0.62	1030	0.69	1061	0.76	1090	0.83	1118	0.89	
3000	877	0.37	918	0.44	957	0.51	994	0.59	1027	0.66	1061	0.74	1093	0.82	1125	0.90	1154	0.98	1182	1.05	
3300	958	0.48	994	0.55	1031	0.63	1066	0.71	1099	0.79	1129	0.87	1159	0.96	1189	1.05	1218	1.14	1246	1.23	
3600	1039	0.61	1070	0.68	1106	0.77	1139	0.86	1170	0.95	1200	1.04	1227	1.12	1255	1.22	1282	1.31	1310	1.41	
External Static Pressure (Inches of Water Gauge)																					
		1.10"		1.20"		1.30"		1.40"		1.50"		1.60"		1.70"		1.80"		1.90"		2.00"	
CFM	RPM	BHP	RPM	BHP	RPM	BHP	RPM	BHP	RPM	BHP	RPM	BHP	RPM	BHP	RPM	BHP	RPM	BHP	RPM	BHP	
2400	1084	0.78	1111	0.83	1137	0.87	1163	0.91	1187	0.95	1210	0.99	1234	1.03	1257	1.06	1279	1.10	1301	1.13	
2700	1146	0.95	1172	1.01	1197	1.06	1222	1.12	1245	1.17	1270	1.22	1292	1.27	1314	1.31	1336	1.36	1357	1.40	
3000	1208	1.13	1234	1.19	1258	1.26	1282	1.33	1306	1.39	1329	1.45	1351	1.51	1373	1.57	1395	1.63	1416	1.69	
3300	1272	1.31	1297	1.39	1322	1.47	1344	1.55	1368	1.63	1390	1.70	1413	1.77	1434	1.85	1454	1.91	1475	1.98	
3600	1336	1.51	1362	1.60	1386	1.69	1409	1.78	1431	1.87	1453	1.96	1475	2.04	1495	2.12	1516	2.21	1537	2.29	

**Notes:**

1. For direct drive evaporator fan speed (rpm), refer to the applicable table in the fan performance section.
2. Data includes pressure drop due to standard filters and wet coils.
3. To determine static pressure drop due to other options/accessories, refer to the applicable table in the fan performance section.
4. Direct drive fan motor heat (MBh) = 2.7912 x fan bhp + 0.1388
5. Factory supplied motors, in commercial equipment, are definite purpose motors, specifically designed and tested to operate reliably and continuously at all cataloged conditions. Using the full horsepower range of our fan motors as shown in our tabular data will not result in nuisance tripping or premature motor failure. Our product's warranty will not be affected.



## Evaporator Fan Performance – Standard Efficiency

**Table 69. Belt drive evaporator fan performance – 7.5 tons standard efficiency with gas heat – YSC092H3,4,W high heat downflow airflow**

External Static Pressure (Inches of Water Gauge)																					
		0.10"		0.20"		0.30"		0.40"		0.50"		0.60"		0.70"		0.80"		0.90"		1.00"	
CFM	RPM	BHP	RPM	BHP	RPM	BHP	RPM	BHP	RPM	BHP	RPM	BHP	RPM	BHP	RPM	BHP	RPM	BHP	RPM	BHP	
1-hp Standard Motor & Field Supplied Low Static Drive <sup>(a)</sup>											1-hp Standard Motor & Drive										
2400	—	—	508	0.40	556	0.48	603	0.56	645	0.65	683	0.73	718	0.81	751	0.90	782	0.98	811	1.06	
2700	500	0.45	549	0.54	592	0.61	635	0.70	676	0.80	714	0.89	749	0.99	782	1.08	812	1.17	842	1.27	
3000	545	0.60	591	0.70	630	0.78	669	0.87	707	0.97	744	1.08	780	1.18	812	1.28	843	1.39	873	1.49	
3300	591	0.77	632	0.88	672	0.98	706	1.07	741	1.18	776	1.29	810	1.40	842	1.52	874	1.63	903	1.75	
3600	637	0.98	675	1.10	713	1.22	747	1.32	778	1.42	810	1.53	843	1.65	874	1.78	904	1.90	933	2.03	

External Static Pressure (Inches of Water Gauge)																					
		1.10"		1.20"		1.30"		1.40"		1.50"		1.60"		1.70"		1.80"		1.90"		2.00"	
CFM	RPM	BHP	RPM	BHP	RPM	BHP	RPM	BHP	RPM	BHP	RPM	BHP	RPM	BHP	RPM	BHP	RPM	BHP	RPM	BHP	
1-hp Standard Motor & Drive											3-hp Oversized Motor & Drive <sup>(b)</sup>										
2400	839	1.15	866	1.23	891	1.31	916	1.39	941	1.48	963	1.56	986	1.64	1008	1.73	1029	1.81	1050	1.89	
2700	869	1.36	895	1.45	921	1.54	946	1.64	969	1.73	992	1.82	1015	1.92	1037	2.01	1058	2.11	1078	2.20	
3000	900	1.59	926	1.70	952	1.80	975	1.90	999	2.01	1022	2.11	1044	2.22	1066	2.32	1088	2.43	1108	2.53	
3300	930	1.86	957	1.98	983	2.09	1007	2.21	1029	2.31	1053	2.43	1075	2.55	1096	2.66	1117	2.77	1137	2.88	
3600	961	2.15	987	2.28	1013	2.41	1037	2.53	1061	2.65	1083	2.78	1105	2.90	1127	3.03	1147	3.15	1168	3.28	

**Notes:**

1. For standard evaporator fan speed (rpm), reference the standard motor and sheave/fan speed applicable table in the fan performance section.
2. Data includes pressure drop due to standard filters and wet coils. No accessories or options are included in pressure drop data.
3. To determine static pressure drop due to other options/accessories, refer to the applicable table in the fan performance section.
4. 1-hp fan motor heat (MBh) = 2.829 x fan bhp + .4024. 3-hp fan motor heat (MBh) = 2.900 x Fan bhp - .3800
5. Factory supplied motors, in commercial equipment, are definite purpose motors, specifically designed and tested to operate reliably and continuously at all cataloged conditions. Using the full horsepower range of our fan motors as shown in our tabular data will not result in nuisance tripping or premature motor failure. Our product's warranty will not be affected.

<sup>(a)</sup> BAYLSDR009A

<sup>(b)</sup> BAYHSMT400A

<sup>(c)</sup> Field Supplied AK56 x 1" Fan Sheave

## Evaporator Fan Performance — Standard Efficiency

**Table 70. Direct drive evaporator fan performance – 7.5 tons standard efficiency Title 24 single zone VAV – YSC092H3,4,W high gas heat downflow airflow**

External Static Pressure (Inches of Water Gauge)																						
		0.10"		0.20"		0.30"		0.40"		0.50"		0.60"		0.70"		0.80"		0.90"		1.00"		
CFM	RPM	BHP	RPM	BHP	RPM	BHP	RPM	BHP	RPM	BHP	RPM	BHP	RPM	BHP	RPM	BHP	RPM	BHP	RPM	BHP	RPM	BHP
2400	741	0.23	786	0.29	828	0.35	869	0.41	910	0.48	945	0.54	978	0.60	1008	0.66	1037	0.72	1065	0.79		
2700	822	0.31	863	0.38	902	0.44	939	0.51	976	0.58	1012	0.65	1046	0.72	1075	0.79	1103	0.86	1131	0.93		
3000	904	0.41	942	0.48	979	0.56	1012	0.63	1046	0.70	1079	0.78	1111	0.87	1142	0.94	1171	1.02	1197	1.09		
3300	987	0.53	1022	0.61	1056	0.69	1088	0.77	1119	0.85	1149	0.93	1179	1.02	1208	1.11	1237	1.20	1266	1.28		
3600	1070	0.67	1103	0.76	1134	0.85	1165	0.93	1194	1.02	1222	1.11	1250	1.20	1278	1.30	1304	1.39	1330	1.49		
External Static Pressure (Inches of Water Gauge)																						
		1.10"		1.20"		1.30"		1.40"		1.50"		1.60"		1.70"		1.80"		1.90"		2.00"		
CFM	RPM	BHP	RPM	BHP	RPM	BHP	RPM	BHP	RPM	BHP	RPM	BHP	RPM	BHP	RPM	BHP	RPM	BHP	RPM	BHP	RPM	BHP
2400	1093	0.85	1119	0.92	1144	0.98	1168	1.05	1192	1.12	1215	1.19	1238	1.26	1260	1.34	1281	1.40	1302	1.48		
2700	1158	1.00	1183	1.07	1207	1.14	1231	1.22	1254	1.29	1277	1.37	1299	1.45	1321	1.52	1341	1.60	1362	1.68		
3000	1223	1.17	1248	1.25	1271	1.33	1296	1.41	1318	1.49	1340	1.57	1362	1.65	1383	1.73	1404	1.81	1423	1.89		
3300	1291	1.37	1315	1.45	1339	1.53	1361	1.62	1384	1.70	1405	1.79	1426	1.88	1446	1.96	1467	2.05	1486	2.14		
3600	1358	1.58	1383	1.68	1406	1.77	1429	1.86	1451	1.95	1471	2.04	1491	2.13	1513	2.23	1532	2.32	1551	2.41		

**Notes:**

1. For direct drive evaporator fan speed (rpm), refer to the applicable table in the fan performance section.
2. Data includes pressure drop due to standard filters and wet coils.
3. To determine static pressure drop due to other options/accessories, refer to the applicable table in the fan performance section.
4. Direct drive fan motor heat (MBh) = 2.7912 x fan bhp + 0.1388
5. Factory supplied motors, in commercial equipment, are definite purpose motors, specifically designed and tested to operate reliably and continuously at all cataloged conditions. Using the full horsepower range of our fan motors as shown in our tabular data will not result in nuisance tripping or premature motor failure. Our product's warranty will not be affected.



## Evaporator Fan Performance – Standard Efficiency

**Table 71. Belt drive evaporator fan performance – 7.5 tons standard efficiency with gas heat – YSC092H3,4,W high heat horizontal airflow**

External Static Pressure (Inches of Water Gauge)																					
		0.10"		0.20"		0.30"		0.40"		0.50"		0.60"		0.70"		0.80"		0.90"		1.00"	
CFM	RPM	BHP	RPM	BHP	RPM	BHP	RPM	BHP	RPM	BHP	RPM	BHP	RPM	BHP	RPM	BHP	RPM	BHP	RPM	BHP	
1-hp Standard Motor & Field Supplied Low Static Drive <sup>(a)</sup>											1-hp Standard Motor & Drive										
2400	548	0.47	593	0.56	635	0.64	674	0.74	709	0.82	744	0.92	777	1.01	808	1.10	837	1.20	865	1.29	
2700	605	0.65	647	0.74	686	0.84	721	0.94	756	1.04	787	1.14	818	1.24	849	1.35	878	1.45	905	1.56	
3000	663	0.86	702	0.97	737	1.08	772	1.18	803	1.29	834	1.41	864	1.52	891	1.63	919	1.74	946	1.86	
3300	722	1.12	757	1.24	791	1.36	823	1.48	853	1.59	882	1.72	911	1.85	938	1.97	964	2.09	988	2.21	
3600	782	1.44	814	1.56	846	1.69	875	1.82	905	1.95	933	2.08	959	2.21	985	2.35	1010	2.49	1034	2.62	
External Static Pressure (Inches of Water Gauge)																					
		1.10"		1.20"		1.30"		1.40"		1.50"		1.60"		1.70"		1.80"		1.90"		2.00"	
CFM	RPM	BHP	RPM	BHP	RPM	BHP	RPM	BHP	RPM	BHP	RPM	BHP	RPM	BHP	RPM	BHP	RPM	BHP	RPM	BHP	
3-hp Oversized Motor & Drive <sup>(b)</sup>																					
2400	892	1.38	917	1.48	942	1.57	966	1.66	989	1.76	1012	1.85	1034	1.94	1055	2.04	1076	2.14	1096	2.23	
2700	931	1.66	957	1.77	982	1.87	1005	1.98	1027	2.08	1050	2.19	1072	2.29	1093	2.40	1113	2.50	1133	2.61	
3000	972	1.98	997	2.10	1021	2.21	1044	2.33	1067	2.45	1089	2.56	1111	2.68	1131	2.80	1152	2.91	1171	3.03	
3300	1014	2.34	1038	2.46	1062	2.59	1085	2.72	1107	2.85	1129	2.98	1151	3.11	1171	3.24	1192	3.37	—	—	
3600	1058	2.75	1081	2.88	1105	3.02	1127	3.16	1149	3.30	1171	3.45	—	—	—	—	—	—	—	—	
3-hp Oversized Motor & Field Supplied High Static Drive <sup>(c)</sup>																					

**Notes:**

- For standard evaporator fan speed (rpm), reference the standard motor and sheave/fan speed applicable table in the fan performance section.
- Data includes pressure drop due to standard filters and wet coils. No accessories or options are included in pressure drop data.
- To determine static pressure drop due to other options/accessories, refer to the applicable table in the fan performance section.
- 1-hp fan motor heat (MBh) = 2.829 x fan bhp + .4024. 3-hp fan motor heat (MBh) = 2.900 x Fan bhp - .3800
- Factory supplied motors, in commercial equipment, are definite purpose motors, specifically designed and tested to operate reliably and continuously at all cataloged conditions. Using the full horsepower range of our fan motors as shown in our tabular data will not result in nuisance tripping or premature motor failure. Our product's warranty will not be affected.

<sup>(a)</sup> BAYLSDR009A

<sup>(b)</sup> BAYHSMT400A

<sup>(c)</sup> Field Supplied AK56 x 1" Fan Sheave

## Evaporator Fan Performance — Standard Efficiency

**Table 72. Direct drive evaporator fan performance – 7.5 tons standard efficiency Title 24 single zone VAV – YSC092H3,4,W high gas heat horizontal airflow**

External Static Pressure (Inches of Water Gauge)																						
		0.10"		0.20"		0.30"		0.40"		0.50"		0.60"		0.70"		0.80"		0.90"		1.00"		
CFM	RPM	BHP	RPM	BHP	RPM	BHP	RPM	BHP	RPM	BHP	RPM	BHP	RPM	BHP	RPM	BHP	RPM	BHP	RPM	BHP	RPM	BHP
2400	720	0.20	768	0.26	815	0.32	859	0.38	901	0.45	936	0.51	972	0.57	1006	0.64	1038	0.70	1069	0.77		
2700	798	0.28	840	0.34	885	0.40	925	0.47	963	0.54	1002	0.62	1035	0.69	1066	0.75	1098	0.83	1128	0.90		
3000	878	0.36	916	0.43	954	0.50	995	0.58	1030	0.65	1065	0.73	1100	0.81	1132	0.90	1160	0.97	1188	1.04		
3300	958	0.47	994	0.54	1027	0.61	1064	0.69	1099	0.78	1131	0.86	1163	0.95	1195	1.04	1227	1.13	1254	1.22		
3600	1039	0.59	1072	0.67	1103	0.75	1134	0.83	1169	0.92	1201	1.01	1230	1.10	1259	1.19	1288	1.29	1318	1.40		
External Static Pressure (Inches of Water Gauge)																						
		1.10"		1.20"		1.30"		1.40"		1.50"		1.60"		1.70"		1.80"		1.90"		2.00"		
CFM	RPM	BHP	RPM	BHP	RPM	BHP	RPM	BHP	RPM	BHP	RPM	BHP	RPM	BHP	RPM	BHP	RPM	BHP	RPM	BHP	RPM	BHP
2400	1099	0.84	1127	0.91	1155	0.98	1181	1.05	1208	1.13	1232	1.20	1257	1.28	1281	1.35	1305	1.43	1328	1.51		
2700	1157	0.98	1185	1.05	1212	1.13	1238	1.20	1264	1.28	1289	1.36	1313	1.44	1336	1.52	1359	1.61	1381	1.69		
3000	1216	1.12	1244	1.21	1271	1.29	1296	1.37	1322	1.46	1346	1.54	1369	1.63	1393	1.71	1416	1.80	1437	1.89		
3300	1278	1.30	1305	1.38	1331	1.47	1355	1.56	1379	1.65	1404	1.74	1427	1.83	1449	1.92	1472	2.02	1494	2.11		
3600	1345	1.50	1369	1.59	1393	1.68	1417	1.77	1440	1.86	1464	1.96	1486	2.06	1509	2.16	1530	2.25	1552	2.36		

**Notes:**

1. For direct drive evaporator fan speed (rpm), refer to the applicable table in the fan performance section.
2. Data includes pressure drop due to standard filters and wet coils.
3. To determine static pressure drop due to other options/accessories, refer to the applicable table in the fan performance section.
4. Direct drive fan motor heat (MBh) = 2.7912 x fan bhp + 0.1388
5. Factory supplied motors, in commercial equipment, are definite purpose motors, specifically designed and tested to operate reliably and continuously at all cataloged conditions. Using the full horsepower range of our fan motors as shown in our tabular data will not result in nuisance tripping or premature motor failure. Our product's warranty will not be affected.



## Evaporator Fan Performance – Standard Efficiency

**Table 73. Belt drive evaporator fan performance – 8.5 tons standard efficiency – TSC102H3,4,W downflow airflow**

External Static Pressure (Inches of Water Gauge)																					
		0.10"		0.20"		0.30"		0.40"		0.50"		0.60"		0.70"		0.80"		0.90"		1.00"	
CFM	RPM	BHP	RPM	BHP	RPM	BHP	RPM	BHP	RPM	BHP	RPM	BHP	RPM	BHP	RPM	BHP	RPM	BHP	RPM	BHP	
<b>2-hp Standard Motor &amp; Field Supplied Low Static Drive<sup>(a)</sup></b>																					
2720	-	-	519	0.43	563	0.50	603	0.57	644	0.65	681	0.73	716	0.81	749	0.88	780	0.96	809	1.03	
3060	513	0.48	558	0.56	604	0.65	640	0.73	676	0.81	713	0.90	747	0.99	779	1.07	810	1.16	840	1.25	
3400	558	0.63	600	0.72	643	0.82	681	0.92	714	1.00	745	1.09	779	1.19	811	1.29	841	1.39	870	1.49	
3740	605	0.82	645	0.92	683	1.02	722	1.13	754	1.24	783	1.33	811	1.42	842	1.53	872	1.64	901	1.75	
4080	654	1.04	691	1.16	724	1.26	760	1.38	795	1.50	824	1.61	851	1.71	876	1.81	904	1.92	932	2.04	
<b>External Static Pressure (Inches of Water Gauge)</b>																					
		1.10"		1.20"		1.30"		1.40"		1.50"		1.60"		1.70"		1.80"		1.90"		2.00"	
CFM	RPM	BHP	RPM	BHP	RPM	BHP	RPM	BHP	RPM	BHP	RPM	BHP	RPM	BHP	RPM	BHP	RPM	BHP	RPM	BHP	
<b>2-hp Standard Motor &amp; Drive</b>																					
2720	838	1.11	865	1.18	891	1.26	916	1.33	940	1.40	963	1.47	986	1.54	1008	1.61	1030	1.69	1051	1.76	
3060	867	1.33	893	1.41	919	1.50	945	1.59	968	1.66	992	1.75	1014	1.83	1037	1.91	1058	2.00	1079	2.08	
3400	897	1.58	923	1.68	949	1.77	974	1.87	997	1.96	1020	2.05	1044	2.15	1065	2.24	1087	2.33	1107	2.42	
3740	928	1.86	954	1.96	980	2.07	1003	2.18	1027	2.28	1050	2.39	1072	2.49	1094	2.59	1115	2.70	1136	2.80	
4080	959	2.16	985	2.29	1010	2.40	1034	2.52	1058	2.64	1079	2.75	1102	2.87	1124	2.98	1145	3.10	1165	3.21	
<b>3-hp Oversized Motor &amp; Drive<sup>(b)</sup></b>																					

**Notes:**

- For standard evaporator fan speed (rpm), reference the standard motor and sheave/fan speed applicable table in the fan performance section.
- Data includes pressure drop due to standard filters and wet coils. No accessories or options are included in pressure drop data.
- To determine static pressure drop due to other options/accessories, refer to the applicable table in the fan performance section.
- 1 hp fan motor heat (MBh) = 2.829 x fan bhp + .4024. 2-hp fan motor heat (MBh) = 2.000 x fan bhp + .5000. 3-hp fan motor heat (MBh) = 2.900 x fan bhp + .4750
- Factory supplied motors, in commercial equipment, are definite purpose motors, specifically designed and tested to operate reliably and continuously at all cataloged conditions. Using the full horsepower range of our fan motors as shown in our tabular data will not result in nuisance tripping or premature motor failure. Our product's warranty will not be affected.
- For electric heat applications, minimum airflow is set to 320 cfm/ton, unless specified otherwise, values found in electric heat temperature rise table.

<sup>(a)</sup> BAYLSDR009A

<sup>(b)</sup> BAYHSMT097A



## Evaporator Fan Performance — Standard Efficiency

**Table 74. Direct drive evaporator fan performance – 8.5 tons standard efficiency Title 24 single zone VAV – TSC102H3,4,W downflow airflow**

External Static Pressure (Inches of Water Gauge)																						
		0.10"		0.20"		0.30"		0.40"		0.50"		0.60"		0.70"		0.80"		0.90"		1.00"		
CFM	RPM	BHP	RPM	BHP	RPM	BHP	RPM	BHP	RPM	BHP	RPM	BHP	RPM	BHP	RPM	BHP	RPM	BHP	RPM	BHP	RPM	BHP
2720	812	0.31	857	0.37	899	0.44	935	0.50	976	0.58	1011	0.65	1040	0.72	1068	0.78	1099	0.85	1129	0.92		
3060	904	0.42	942	0.49	983	0.57	1017	0.64	1049	0.71	1086	0.80	1119	0.89	1149	0.96	1174	1.03	1197	1.10		
3400	997	0.55	1030	0.63	1066	0.71	1103	0.81	1132	0.89	1160	0.96	1193	1.06	1225	1.16	1254	1.25	1279	1.33		
3740	1090	0.72	1120	0.80	1152	0.89	1185	0.99	1218	1.09	1244	1.17	1269	1.25	1298	1.36	1329	1.47	1356	1.57		
4080	1183	0.92	1211	1.01	1240	1.10	1270	1.20	1301	1.31	1330	1.42	1354	1.51	1377	1.60	1402	1.70	1430	1.82		
External Static Pressure (Inches of Water Gauge)																						
		1.10"		1.20"		1.30"		1.40"		1.50"		1.60"		1.70"		1.80"		1.90"		2.00"		
CFM	RPM	BHP	RPM	BHP	RPM	BHP	RPM	BHP	RPM	BHP	RPM	BHP	RPM	BHP	RPM	BHP	RPM	BHP	RPM	BHP	RPM	BHP
2720	1158	0.99	1186	1.05	1213	1.11	1238	1.18	1264	1.24	1289	1.30	1313	1.36	1336	1.42	1359	1.47	1382	1.53		
3060	1226	1.18	1253	1.26	1279	1.33	1305	1.41	1329	1.48	1353	1.55	1377	1.63	1400	1.70	1422	1.76	1444	1.83		
3400	1301	1.40	1323	1.48	1347	1.56	1372	1.65	1396	1.74	1421	1.83	1444	1.91	1465	1.99	1487	2.07	1509	2.15		
3740	1382	1.67	1406	1.76	1426	1.84	1445	1.92	1465	2.01	1489	2.11	1510	2.20	1533	2.30	1554	2.39	1576	2.49		
4080	1457	1.94	1482	2.05	1506	2.16	1527	2.26	1546	2.35	1565	2.44	1583	2.53	1602	2.63	1623	2.73	1643	2.84		

**Notes:**

1. For direct drive evaporator fan speed (rpm), refer to the applicable table in the fan performance section.
2. Data includes pressure drop due to standard filters and wet coils.
3. To determine static pressure drop due to other options/accessories, refer to the applicable table in the fan performance section.
4. Direct drive fan motor heat (MBh) = 2.7912 x fan bhp + 0.1388
5. Factory supplied motors, in commercial equipment, are definite purpose motors, specifically designed and tested to operate reliably and continuously at all cataloged conditions. Using the full horsepower range of our fan motors as shown in our tabular data will not result in nuisance tripping or premature motor failure. Our product's warranty will not be affected.



## Evaporator Fan Performance – Standard Efficiency

**Table 75. Belt drive evaporator fan performance – 8.5 tons standard efficiency – TSC102H3,4,W horizontal airflow**

External Static Pressure (Inches of Water Gauge)																						
		0.10"		0.20"		0.30"		0.40"		0.50"		0.60"		0.70"		0.80"		0.90"		1.00"		
CFM	RPM	BHP	RPM	BHP	RPM	BHP	RPM	BHP	RPM	BHP	RPM	BHP	RPM	BHP	RPM	BHP	RPM	BHP	RPM	BHP	RPM	BHP
<b>2-hp Standard Motor &amp; Field Supplied Low Static Drive Accessory Kit<sup>(a)</sup></b>											<b>2-hp Standard Motor &amp; Drive</b>											
2720	523	0.43	571	0.50	619	0.59	676	0.69	721	0.80	759	0.90	795	1.00	830	1.10	862	1.20	893	1.30		
3060	578	0.59	625	0.68	659	0.75	706	0.86	757	0.98	800	1.10	834	1.21	866	1.33	899	1.44	929	1.55		
3400	633	0.79	673	0.88	710	0.97	744	1.07	788	1.19	833	1.32	874	1.46	907	1.58	937	1.71	967	1.84		
3740	690	1.03	723	1.12	764	1.24	791	1.33	825	1.44	864	1.57	907	1.72	945	1.87	979	2.02	1007	2.15		
4080	747	1.31	777	1.41	812	1.53	844	1.65	869	1.75	901	1.87	938	2.02	976	2.18	1013	2.35	1048	2.51		
											<b>3-hp Oversized Motor &amp; Drive<sup>(b)</sup></b>											
External Static Pressure (Inches of Water Gauge)																						
		1.10"		1.20"		1.30"		1.40"		1.50"		1.60"		1.70"		1.80"		1.90"		2.00"		
CFM	RPM	BHP	RPM	BHP	RPM	BHP	RPM	BHP	RPM	BHP	RPM	BHP	RPM	BHP	RPM	BHP	RPM	BHP	RPM	BHP	RPM	BHP
<b>2-hp Standard Motor &amp; Drive</b>																						
2720	924	1.40	952	1.50	980	1.60	1006	1.70	1032	1.81	1057	1.91	1081	2.01	1105	2.11	1127	2.21	1150	2.31		
3060	959	1.66	987	1.77	1014	1.89	1041	2.01	1066	2.11	1091	2.23	1115	2.34	1138	2.46	1161	2.57	1184	2.69		
3400	995	1.96	1024	2.09	1051	2.21	1077	2.34	1102	2.46	1126	2.59	1150	2.72	1173	2.84	1196	2.97	1217	3.09		
3740	1034	2.29	1060	2.43	1087	2.57	1113	2.71	1138	2.84	1162	2.98	1185	3.12	1208	3.25	1230	3.39	-	-		
4080	1076	2.66	1101	2.81	1126	2.96	1150	3.11	1175	3.26	1198	3.41	-	-	-	-	-	-	-	-		
											<b>3-hp Oversized Motor &amp; Drive<sup>(c)</sup></b>											

**Notes:**

- For standard evaporator fan speed (rpm), reference the standard motor and sheave/fan speed applicable table in the fan performance section.
- Data includes pressure drop due to standard filters and wet coils. No accessories or options are included in pressure drop data.
- To determine static pressure drop due to other options/accessories, refer to the applicable table in the fan performance section.
- 1 hp fan motor heat (MBh) = 2.829 x fan bhp + .4024. 2-hp fan motor heat (MBh) = 2.000 x fan bhp + .5000. 3-hp fan motor heat (MBh) = 2.900 x fan bhp + .4750
- Factory supplied motors, in commercial equipment, are definite purpose motors, specifically designed and tested to operate reliably and continuously at all cataloged conditions. Using the full horsepower range of our fan motors as shown in our tabular data will not result in nuisance tripping or premature motor failure. Our product's warranty will not be affected.
- For electric heat applications, minimum airflow is set to 320 cfm/ton, unless specified otherwise, values found in electric heat temperature rise table.

(a) BAYLSDR009A  
 (b) BAYHSMT097A  
 (c) BAYHSMT097A

## Evaporator Fan Performance — Standard Efficiency

**Table 76. Direct drive evaporator fan performance – 8.5 tons standard efficiency Title 24 single zone VAV – TSC102H3,4,W horizontal airflow**

External Static Pressure (Inches of Water Gauge)																						
		0.10"		0.20"		0.30"		0.40"		0.50"		0.60"		0.70"		0.80"		0.90"		1.00"		
CFM	RPM	BHP	RPM	BHP	RPM	BHP	RPM	BHP	RPM	BHP	RPM	BHP	RPM	BHP	RPM	BHP	RPM	BHP	RPM	BHP	RPM	BHP
2720	821	0.31	864	0.38	911	0.45	947	0.52	982	0.58	1015	0.65	1046	0.71	1077	0.78	1107	0.85	1137	0.93		
3060	914	0.43	951	0.50	993	0.58	1032	0.66	1063	0.73	1095	0.81	1125	0.88	1153	0.95	1181	1.03	1208	1.10		
3400	1008	0.57	1041	0.64	1076	0.73	1115	0.82	1148	0.91	1177	0.99	1204	1.07	1232	1.15	1259	1.24	1284	1.32		
3740	1103	0.75	1132	0.82	1163	0.91	1197	1.01	1232	1.11	1262	1.21	1288	1.30	1313	1.38	1339	1.47	1364	1.57		
4080	1198	0.95	1225	1.04	1253	1.13	1281	1.22	1314	1.33	1345	1.45	1372	1.55	1397	1.65	1420	1.75	1444	1.84		
External Static Pressure (Inches of Water Gauge)																						
		1.10"		1.20"		1.30"		1.40"		1.50"		1.60"		1.70"		1.80"		1.90"		2.00"		
CFM	RPM	BHP	RPM	BHP	RPM	BHP	RPM	BHP	RPM	BHP	RPM	BHP	RPM	BHP	RPM	BHP	RPM	BHP	RPM	BHP	RPM	BHP
2720	1165	1.00	1193	1.07	1220	1.15	1245	1.22	1271	1.30	1296	1.38	1322	1.47	1344	1.55	1368	1.63	1391	1.72		
3060	1235	1.18	1261	1.26	1288	1.34	1313	1.43	1337	1.51	1361	1.59	1385	1.68	1408	1.77	1431	1.86	1453	1.95		
3400	1310	1.40	1334	1.48	1359	1.57	1382	1.66	1406	1.75	1430	1.84	1453	1.93	1474	2.02	1496	2.12	1518	2.21		
3740	1388	1.66	1411	1.75	1433	1.83	1456	1.93	1477	2.02	1500	2.11	1522	2.21	1544	2.31	1565	2.41	1586	2.51		
4080	1467	1.95	1489	2.04	1512	2.14	1533	2.24	1554	2.34	1575	2.43	1594	2.53	1616	2.64	1636	2.74	-	-		

**Notes:**

1. For direct drive evaporator fan speed (rpm), refer to the applicable table in the fan performance section.
2. Data includes pressure drop due to standard filters and wet coils.
3. To determine static pressure drop due to other options/accessories, refer to the applicable table in the fan performance section.
4. Direct drive fan motor heat (MBh) = 2.7912 x fan bhp + 0.1388
5. Factory supplied motors, in commercial equipment, are definite purpose motors, specifically designed and tested to operate reliably and continuously at all cataloged conditions. Using the full horsepower range of our fan motors as shown in our tabular data will not result in nuisance tripping or premature motor failure. Our product's warranty will not be affected.



## Evaporator Fan Performance – Standard Efficiency

**Table 77. Belt drive evaporator fan performance – 8.5 tons standard efficiency with gas heat – YSC102H3,4,W\*L low heat downflow airflow**

External Static Pressure (Inches of Water Gauge)																						
		0.10"		0.20"		0.30"		0.40"		0.50"		0.60"		0.70"		0.80"		0.90"		1.00"		
CFM	RPM	BHP	RPM	BHP	RPM	BHP	RPM	BHP	RPM	BHP	RPM	BHP	RPM	BHP	RPM	BHP	RPM	BHP	RPM	BHP	RPM	BHP
<b>2-hp Standard Motor &amp; Low Static Drive<sup>(a)</sup></b>																						
2720	-	-	536	0.45	581	0.52	623	0.60	663	0.68	701	0.75	735	0.82	768	0.90	799	0.96	829	1.03		
3060	543	0.53	582	0.60	623	0.68	662	0.76	698	0.85	735	0.94	768	1.02	801	1.11	831	1.18	861	1.26		
3400	595	0.72	631	0.79	665	0.87	703	0.96	737	1.05	770	1.15	803	1.25	835	1.34	865	1.44	894	1.53		
3740	647	0.93	680	1.02	712	1.10	744	1.19	778	1.29	809	1.40	839	1.50	870	1.61	899	1.72	927	1.82		
4080	699	1.19	731	1.29	760	1.38	789	1.47	820	1.58	851	1.68	879	1.80	907	1.92	934	2.03	961	2.15		
<b>External Static Pressure (Inches of Water Gauge)</b>																						
		1.10"		1.20"		1.30"		1.40"		1.50"		1.60"		1.70"		1.80"		1.90"		2.00"		
CFM	RPM	BHP	RPM	BHP	RPM	BHP	RPM	BHP	RPM	BHP	RPM	BHP	RPM	BHP	RPM	BHP	RPM	BHP	RPM	BHP	RPM	BHP
<b>2-hp Standard Motor &amp; Drive</b>																						
2720	857	1.10	884	1.16	910	1.22	935	1.29	960	1.35	983	1.41	1006	1.47	1028	1.53	1050	1.59	1072	1.65		
3060	889	1.34	915	1.42	941	1.49	966	1.57	990	1.64	1013	1.71	1036	1.78	1059	1.85	1080	1.92	1101	1.99		
3400	921	1.62	948	1.70	973	1.79	998	1.88	1022	1.96	1045	2.04	1068	2.13	1089	2.21	1111	2.29	1132	2.37		
3740	954	1.92	981	2.02	1006	2.12	1029	2.22	1054	2.32	1077	2.41	1099	2.50	1120	2.60	1142	2.69	1162	2.78		
4080	989	2.27	1014	2.38	1039	2.49	1063	2.60	1086	2.70	1108	2.81	1130	2.91	1153	3.02	1174	3.12	1194	3.23		
<b>3-hp Oversized Motor &amp; Drive<sup>(b)</sup></b>																						

**Notes:**

1. For standard evaporator fan speed (rpm), reference the standard motor and sheave/fan speed applicable table in the fan performance section.
2. Data includes pressure drop due to standard filters and wet coils. No accessories or options are included in pressure drop data.
3. To determine static pressure drop due to other options/accessories, refer to the applicable table in the fan performance section.
4. 2-hp fan motor heat (MBh) = 2.000 x fan bhp + .5000. 3-hp fan motor heat (MBh) = 2.900 x fan bhp + .4750
5. Factory supplied motors, in commercial equipment, are definite purpose motors, specifically designed and tested to operate reliably and continuously at all cataloged conditions. Using the full horsepower range of our fan motors as shown in our tabular data will not result in nuisance tripping or premature motor failure. Our product's warranty will not be affected.

<sup>(a)</sup> BAYLSDR009A

<sup>(b)</sup> BAYHSMT097A

## Evaporator Fan Performance — Standard Efficiency

**Table 78. Belt drive evaporator fan performance – 8.5 tons standard efficiency with gas heat – YSC102H3,4,W\*L low heat horizontal airflow**

External Static Pressure (Inches of Water Gauge)																					
		0.10"		0.20"		0.30"		0.40"		0.50"		0.60"		0.70"		0.80"		0.90"		1.00"	
CFM	RPM	BHP	RPM	BHP	RPM	BHP	RPM	BHP	RPM	BHP	RPM	BHP	RPM	BHP	RPM	BHP	RPM	BHP	RPM	BHP	
2-hp Standard Motor & Low Static Drive <sup>(a)</sup>											2-hp Standard Motor & Drive										
2720	573	0.50	620	0.59	660	0.67	701	0.75	739	0.83	774	0.91	808	1.00	839	1.09	869	1.17	898	1.26	
3060	633	0.69	677	0.79	714	0.88	749	0.97	787	1.06	820	1.15	853	1.24	884	1.34	913	1.44	941	1.54	
3400	696	0.93	734	1.03	770	1.14	803	1.23	835	1.33	869	1.44	899	1.54	929	1.64	957	1.74	985	1.85	
3740	759	1.22	791	1.32	828	1.44	858	1.55	887	1.66	917	1.77	948	1.88	976	1.99	1004	2.11	1030	2.22	
4080	823	1.56	851	1.67	885	1.80	916	1.92	943	2.04	969	2.16	996	2.28	1025	2.40	1052	2.53	1078	2.65	
3-hp Oversized Motor & Drive <sup>(b)</sup>																					
External Static Pressure (Inches of Water Gauge)																					
		1.10"		1.20"		1.30"		1.40"		1.50"		1.60"		1.70"		1.80"		1.90"		2.00"	
CFM	RPM	BHP	RPM	BHP	RPM	BHP	RPM	BHP	RPM	BHP	RPM	BHP	RPM	BHP	RPM	BHP	RPM	BHP	RPM	BHP	
2-hp Standard Motor & Drive																					
2720	926	1.34	952	1.43	978	1.51	1001	1.59	1026	1.68	1049	1.76	1071	1.84	1092	1.93	1115	2.02	1135	2.10	
3060	968	1.63	994	1.73	1019	1.82	1043	1.92	1067	2.02	1090	2.11	1112	2.20	1133	2.30	1154	2.39	1174	2.48	
3400	1011	1.96	1037	2.07	1061	2.18	1085	2.28	1109	2.39	1131	2.50	1153	2.60	1174	2.71	1195	2.81	1215	2.92	
3740	1055	2.33	1081	2.45	1105	2.57	1129	2.69	1151	2.81	1174	2.93	1195	3.04	1216	3.16	1237	3.28	1257	3.40	
4080	1102	2.77	1126	2.89	1150	3.02	1173	3.15	1196	3.28	1217	3.41	-	-	-	-	-	-	-	-	
3-hp Oversized Motor & Drive <sup>(c)</sup>																					

**Notes:**

1. For standard evaporator fan speed (rpm), reference the standard motor and sheave/fan speed applicable table in the fan performance section.
2. Data includes pressure drop due to standard filters and wet coils. No accessories or options are included in pressure drop data.
3. To determine static pressure drop due to other options/accessories, refer to the applicable table in the fan performance section.
4. 2-hp fan motor heat (MBh) = 2.000 x fan bhp + .5000. 3-hp fan motor heat (MBh) = 2.900 x fan bhp + .4750
5. Factory supplied motors, in commercial equipment, are definite purpose motors, specifically designed and tested to operate reliably and continuously at all cataloged conditions. Using the full horsepower range of our fan motors as shown in our tabular data will not result in nuisance tripping or premature motor failure. Our product's warranty will not be affected.

<sup>(a)</sup> BAYLSDR009A

<sup>(b)</sup> BAYHSMT097A

<sup>(c)</sup> BAYHSMT097A



## Evaporator Fan Performance – Standard Efficiency

**Table 79. Belt drive evaporator fan performance – 8.5 tons with gas heat – YSC102H3,4,W\*M medium heat downflow airflow**

External Static Pressure (Inches of Water Gauge)																						
		0.10"		0.20"		0.30"		0.40"		0.50"		0.60"		0.70"		0.80"		0.90"		1.00"		
CFM	RPM	BHP	RPM	BHP	RPM	BHP	RPM	BHP	RPM	BHP	RPM	BHP	RPM	BHP	RPM	BHP	RPM	BHP	RPM	BHP	RPM	BHP
<b>2-hp Standard Motor &amp; Low Static Drive<sup>(a)</sup></b>																						
2720	-	-	545	0.47	588	0.54	631	0.62	672	0.70	703	0.77	732	0.83	761	0.89	787	0.95	812	1.01		
3060	542	0.53	594	0.63	632	0.70	669	0.79	707	0.88	747	0.98	775	1.05	802	1.12	828	1.19	853	1.26		
3400	592	0.71	641	0.82	677	0.90	713	1.00	745	1.09	779	1.18	816	1.30	845	1.39	870	1.47	894	1.54		
3740	645	0.93	687	1.04	726	1.15	756	1.23	789	1.34	818	1.44	848	1.54	883	1.67	913	1.78	937	1.87		
4080	699	1.19	732	1.29	774	1.43	804	1.53	832	1.63	862	1.75	889	1.85	915	1.96	947	2.10	978	2.24		
<b>External Static Pressure (Inches of Water Gauge)</b>																						
		1.10"		1.20"		1.30"		1.40"		1.50"		1.60"		1.70"		1.80"		1.90"		2.00"		
CFM	RPM	BHP	RPM	BHP	RPM	BHP	RPM	BHP	RPM	BHP	RPM	BHP	RPM	BHP	RPM	BHP	RPM	BHP	RPM	BHP	RPM	BHP
<b>2-hp Standard Motor &amp; Drive</b>																						
2720	836	1.07	859	1.12	882	1.18	903	1.23	924	1.29	944	1.34	965	1.39	983	1.45	1002	1.50	1021	1.55		
3060	876	1.32	899	1.39	921	1.45	942	1.52	962	1.58	983	1.65	1002	1.71	1021	1.77	1040	1.83	1058	1.89		
3400	917	1.62	940	1.70	961	1.77	982	1.85	1003	1.92	1022	1.99	1042	2.07	1060	2.14	1078	2.21	1096	2.27		
3740	960	1.96	982	2.05	1002	2.13	1023	2.22	1043	2.30	1062	2.38	1081	2.46	1099	2.54	1118	2.62	1135	2.70		
4080	1003	2.35	1024	2.44	1045	2.54	1065	2.63	1084	2.72	1104	2.82	1122	2.91	1141	3.00	1158	3.09	1175	3.18		
<b>3-hp Oversized Motor &amp; Drive<sup>(b)</sup></b>																						

**Notes:**

1. For standard evaporator fan speed (rpm), reference the standard motor and sheave/fan speed applicable table in the fan performance section.
2. Data includes pressure drop due to standard filters and wet coils. No accessories or options are included in pressure drop data.
3. To determine static pressure drop due to other options/accessories, refer to the applicable table in the fan performance section.
4. 2-hp fan motor heat (MBh) = 2.000 x fan bhp + .5000. 3-hp fan motor heat (MBh) = 2.900 x fan bhp + .4750
5. Factory supplied motors, in commercial equipment, are definite purpose motors, specifically designed and tested to operate reliably and continuously at all cataloged conditions. Using the full horsepower range of our fan motors as shown in our tabular data will not result in nuisance tripping or premature motor failure. Our product's warranty will not be affected.

<sup>(a)</sup> BAYLSDR009A

<sup>(b)</sup> BAYHSMT097A

## Evaporator Fan Performance — Standard Efficiency

**Table 80. Belt drive evaporator fan performance – 8.5 tons with gas heat – YSC102H3,4,W\*M medium heat horizontal airflow**

External Static Pressure (Inches of Water Gauge)																					
		0.10"		0.20"		0.30"		0.40"		0.50"		0.60"		0.70"		0.80"		0.90"		1.00"	
CFM	RPM	BHP	RPM	BHP	RPM	BHP	RPM	BHP	RPM	BHP	RPM	BHP	RPM	BHP	RPM	BHP	RPM	BHP	RPM	BHP	
<b>2-hp Standard Motor &amp; Low Static Drive<sup>(a)</sup></b>											<b>2-hp Standard Motor &amp; Drive</b>										
2720	592	0.55	636	0.63	677	0.72	717	0.81	755	0.90	788	0.99	816	1.05	845	1.12	877	1.21	909	1.30	
3060	655	0.75	695	0.85	733	0.95	769	1.05	805	1.15	839	1.25	870	1.35	897	1.44	922	1.51	947	1.58	
3400	719	1.01	756	1.12	791	1.23	825	1.33	855	1.44	888	1.55	920	1.66	949	1.78	976	1.89	999	1.98	
3740	783	1.32	818	1.44	850	1.55	881	1.67	912	1.80	940	1.91	969	2.03	999	2.16	1027	2.29	1052	2.41	
4080	848	1.69	881	1.81	911	1.94	939	2.07	969	2.21	996	2.34	1022	2.46	1048	2.60	1075	2.73	1102	2.86	
<b>External Static Pressure (Inches of Water Gauge)</b>																					
		1.10"		1.20"		1.30"		1.40"		1.50"		1.60"		1.70"		1.80"		1.90"		2.00"	
CFM	RPM	BHP	RPM	BHP	RPM	BHP	RPM	BHP	RPM	BHP	RPM	BHP	RPM	BHP	RPM	BHP	RPM	BHP	RPM	BHP	
<b>2-hp Standard Motor &amp; Drive</b>											<b>3-hp Oversized Motor &amp; Drive<sup>(b)</sup></b>										
2720	938	1.39	967	1.48	994	1.57	1020	1.66	1045	1.74	1071	1.83	1094	1.91	1119	2.00	1142	2.09	1163	2.17	
3060	976	1.69	1004	1.79	1031	1.89	1057	1.99	1082	2.09	1107	2.19	1131	2.29	1154	2.38	1177	2.48	1198	2.58	
3400	1022	2.06	1044	2.14	1070	2.25	1096	2.36	1121	2.48	1145	2.59	1168	2.70	1191	2.81	1213	2.92	1236	3.03	
3740	1076	2.53	1097	2.63	1117	2.71	1137	2.80	1159	2.90	1184	3.03	1206	3.15	1230	3.28	1252	3.40	-	-	
4080	1126	3.01	1150	3.15	1172	3.28	1192	3.38	-	-	-	-	-	-	-	-	-	-	-	-	

**Notes:**

1. For standard evaporator fan speed (rpm), reference the standard motor and sheave/fan speed applicable table in the fan performance section.
2. Data includes pressure drop due to standard filters and wet coils. No accessories or options are included in pressure drop data.
3. To determine static pressure drop due to other options/accessories, refer to the applicable table in the fan performance section.
4. 2-hp fan motor heat (MBh) = 2.000 x fan bhp + .5000. 3-hp fan motor heat (MBh) = 2.900 x fan bhp + .4750
5. Factory supplied motors, in commercial equipment, are definite purpose motors, specifically designed and tested to operate reliably and continuously at all cataloged conditions. Using the full horsepower range of our fan motors as shown in our tabular data will not result in nuisance tripping or premature motor failure. Our product's warranty will not be affected.

<sup>(a)</sup> BAYLSDR009A

<sup>(b)</sup> BAYHSMT097A



## Evaporator Fan Performance – Standard Efficiency

**Table 81. Direct drive evaporator fan performance – 8.5 tons standard efficiency Title 24 single zone VAV – YSC102H3,4,W low and medium gas heat downflow airflow**

External Static Pressure (Inches of Water Gauge)																						
		0.10"		0.20"		0.30"		0.40"		0.50"		0.60"		0.70"		0.80"		0.90"		1.00"		
CFM	RPM	BHP	RPM	BHP	RPM	BHP	RPM	BHP	RPM	BHP	RPM	BHP	RPM	BHP	RPM	BHP	RPM	BHP	RPM	BHP	RPM	BHP
2720	825	0.32	865	0.38	905	0.45	943	0.52	981	0.59	1020	0.67	1051	0.73	1079	0.80	1112	0.87	1144	0.95		
3060	918	0.43	955	0.50	990	0.58	1025	0.65	1059	0.73	1092	0.81	1128	0.90	1160	0.98	1186	1.05	1211	1.12		
3400	1011	0.57	1046	0.66	1078	0.73	1110	0.82	1141	0.90	1171	0.99	1202	1.08	1233	1.17	1264	1.27	1292	1.36		
3740	1106	0.75	1138	0.84	1168	0.92	1196	1.01	1225	1.10	1253	1.20	1281	1.29	1309	1.39	1336	1.49	1365	1.59		
4080	1201	0.95	1230	1.05	1259	1.15	1285	1.24	1311	1.33	1338	1.43	1363	1.54	1389	1.64	1415	1.75	1439	1.86		
External Static Pressure (Inches of Water Gauge)																						
		1.10"		1.20"		1.30"		1.40"		1.50"		1.60"		1.70"		1.80"		1.90"		2.00"		
CFM	RPM	BHP	RPM	BHP	RPM	BHP	RPM	BHP	RPM	BHP	RPM	BHP	RPM	BHP	RPM	BHP	RPM	BHP	RPM	BHP	RPM	BHP
2720	1175	1.03	1203	1.10	1231	1.18	1260	1.27	1286	1.35	1311	1.43	1336	1.52	1360	1.60	1385	1.69	1408	1.78		
3060	1240	1.21	1269	1.29	1297	1.38	1323	1.47	1349	1.56	1374	1.64	1399	1.74	1424	1.83	1447	1.92	1470	2.02		
3400	1316	1.44	1338	1.52	1363	1.60	1389	1.70	1414	1.79	1439	1.89	1464	1.99	1488	2.09	1510	2.18	1533	2.29		
3740	1393	1.70	1419	1.80	1440	1.88	1461	1.97	1482	2.06	1506	2.16	1530	2.27	1552	2.37	1576	2.48	1597	2.58		
4080	1465	1.96	1491	2.08	1517	2.19	1541	2.30	1562	2.40	1581	2.49	1600	2.59	1619	2.69	1641	2.80	-	-		

**Notes:**

1. For direct drive evaporator fan speed (rpm), refer to the applicable table in the fan performance section.
2. Data includes pressure drop due to standard filters and wet coils.
3. To determine static pressure drop due to other options/accessories, refer to the applicable table in the fan performance section.
4. Direct drive fan motor heat (MBh) = 2.7912 x fan bhp + 0.1388
5. Factory supplied motors, in commercial equipment, are definite purpose motors, specifically designed and tested to operate reliably and continuously at all cataloged conditions. Using the full horsepower range of our fan motors as shown in our tabular data will not result in nuisance tripping or premature motor failure. Our product's warranty will not be affected.



## Evaporator Fan Performance — Standard Efficiency

**Table 82. Direct drive evaporator fan performance – 8.5 tons standard efficiency Title 24 single zone VAV – YSC102H3,4,W low and medium gas heat horizontal airflow**

External Static Pressure (Inches of Water Gauge)																						
		0.10"		0.20"		0.30"		0.40"		0.50"		0.60"		0.70"		0.80"		0.90"		1.00"		
CFM	RPM	BHP	RPM	BHP	RPM	BHP	RPM	BHP	RPM	BHP	RPM	BHP	RPM	BHP	RPM	BHP	RPM	BHP	RPM	BHP	RPM	BHP
2720	820	0.31	865	0.38	906	0.45	943	0.51	979	0.59	1016	0.66	1048	0.73	1078	0.80	1107	0.87	1135	0.93		
3060	911	0.42	953	0.50	991	0.57	1026	0.65	1059	0.73	1092	0.81	1124	0.89	1154	0.97	1183	1.05	1210	1.13		
3400	1004	0.56	1042	0.65	1077	0.73	1111	0.81	1142	0.90	1171	0.98	1200	1.07	1230	1.17	1258	1.26	1286	1.35		
3740	1098	0.73	1131	0.82	1165	0.91	1196	1.00	1227	1.10	1255	1.19	1281	1.28	1308	1.38	1335	1.48	1362	1.58		
4080	1193	0.93	1222	1.02	1254	1.13	1283	1.22	1311	1.32	1340	1.43	1365	1.53	1389	1.63	1414	1.73	1439	1.84		
External Static Pressure (Inches of Water Gauge)																						
		1.10"		1.20"		1.30"		1.40"		1.50"		1.60"		1.70"		1.80"		1.90"		2.00"		
CFM	RPM	BHP	RPM	BHP	RPM	BHP	RPM	BHP	RPM	BHP	RPM	BHP	RPM	BHP	RPM	BHP	RPM	BHP	RPM	BHP	RPM	BHP
2720	1163	0.99	1189	1.05	1214	1.10	1239	1.16	1262	1.21	1285	1.26	1308	1.31	1330	1.36	1351	1.40	1372	1.44		
3060	1236	1.20	1261	1.28	1285	1.34	1310	1.41	1332	1.48	1355	1.54	1377	1.60	1399	1.66	1420	1.72	1440	1.78		
3400	1311	1.43	1336	1.52	1360	1.60	1382	1.68	1406	1.77	1427	1.84	1449	1.92	1470	1.99	1490	2.06	1511	2.13		
3740	1387	1.69	1413	1.79	1436	1.88	1458	1.97	1479	2.07	1502	2.16	1523	2.25	1542	2.33	1563	2.42	1582	2.50		
4080	1463	1.96	1487	2.07	1512	2.18	1534	2.29	1556	2.39	1578	2.50	1598	2.60	1617	2.70	1637	2.80	-	-		

**Notes:**

1. For direct drive evaporator fan speed (rpm), refer to the applicable table in the fan performance section.
2. Data includes pressure drop due to standard filters and wet coils.
3. To determine static pressure drop due to other options/accessories, refer to the applicable table in the fan performance section.
4. Direct drive fan motor heat (MBh) = 2.7912 x fan bhp + 0.1388
5. Factory supplied motors, in commercial equipment, are definite purpose motors, specifically designed and tested to operate reliably and continuously at all cataloged conditions. Using the full horsepower range of our fan motors as shown in our tabular data will not result in nuisance tripping or premature motor failure. Our product's warranty will not be affected.



## Evaporator Fan Performance – Standard Efficiency

**Table 83. Belt drive evaporator fan performance – 8.5 tons standard efficiency with gas heat – YSC102H3,4,W\*H high heat downflow airflow**

External Static Pressure (Inches of Water Gauge)																					
		0.10"		0.20"		0.30"		0.40"		0.50"		0.60"		0.70"		0.80"		0.90"		1.00"	
CFM	RPM	BHP	RPM	BHP	RPM	BHP	RPM	BHP	RPM	BHP	RPM	BHP	RPM	BHP	RPM	BHP	RPM	BHP	RPM	BHP	
<b>2-hp Standard Motor &amp; Low Static Drive<sup>(a)</sup></b>											<b>2-hp Standard Motor &amp; Drive</b>										
2720	-	-	552	0.48	595	0.56	634	0.63	672	0.71	710	0.79	745	0.87	778	0.95	809	1.02	839	1.10	
3060	560	0.57	602	0.65	639	0.73	677	0.81	711	0.89	745	0.97	779	1.07	812	1.16	842	1.25	871	1.33	
3400	614	0.76	651	0.84	686	0.93	721	1.02	754	1.12	785	1.21	815	1.30	846	1.40	877	1.50	905	1.60	
3740	667	0.99	700	1.07	736	1.19	766	1.28	798	1.38	828	1.48	856	1.58	884	1.68	911	1.78	940	1.90	
4080	720	1.26	753	1.36	785	1.47	815	1.58	843	1.68	872	1.79	899	1.91	926	2.02	951	2.12	976	2.24	
<b>External Static Pressure (Inches of Water Gauge)</b>																					
		1.10"		1.20"		1.30"		1.40"		1.50"		1.60"		1.70"		1.80"		1.90"		2.00"	
CFM	RPM	BHP	RPM	BHP	RPM	BHP	RPM	BHP	RPM	BHP	RPM	BHP	RPM	BHP	RPM	BHP	RPM	BHP	RPM	BHP	
<b>2-hp Standard Motor &amp; Drive</b>											<b>3-hp Oversized Motor &amp; Drive<sup>(b)</sup></b>										
2720	867	1.18	895	1.25	921	1.33	946	1.40	971	1.48	995	1.55	1018	1.62	1040	1.69	1062	1.76	1084	1.84	
3060	900	1.42	927	1.51	953	1.60	979	1.68	1003	1.77	1026	1.85	1049	1.94	1070	2.02	1092	2.10	1113	2.18	
3400	933	1.70	960	1.80	985	1.90	1010	1.99	1034	2.09	1058	2.19	1080	2.28	1102	2.37	1124	2.47	1145	2.56	
3740	967	2.01	993	2.12	1019	2.23	1043	2.33	1067	2.45	1090	2.55	1113	2.66	1135	2.77	1155	2.87	1176	2.97	
4080	1002	2.35	1027	2.47	1052	2.59	1076	2.71	1100	2.83	1123	2.95	1145	3.07	1168	3.20	1189	3.31	1209	3.43	

**Notes:**

1. For standard evaporator fan speed (rpm), reference the standard motor and sheave/fan speed applicable table in the fan performance section.
2. Data includes pressure drop due to standard filters and wet coils. No accessories or options are included in pressure drop data.
3. To determine static pressure drop due to other options/accessories, refer to the applicable table in the fan performance section.
4. 2-hp fan motor heat (MBh) = 2.000 x fan bhp + .5000. 3-hp fan motor heat (MBh) = 2.900 x fan bhp + .4750
5. Factory supplied motors, in commercial equipment, are definite purpose motors, specifically designed and tested to operate reliably and continuously at all cataloged conditions. Using the full horsepower range of our fan motors as shown in our tabular data will not result in nuisance tripping or premature motor failure. Our product's warranty will not be affected.

<sup>(a)</sup> BAYLSDR009A

<sup>(b)</sup> BAYHSMT097A

## Evaporator Fan Performance — Standard Efficiency

**Table 84. Direct drive evaporator fan performance – 8.5 tons standard efficiency Title 24 single zone VAV – YSC102H3,4,W\*H high gas heat downflow airflow**

External Static Pressure (Inches of Water Gauge)																						
		0.10"		0.20"		0.30"		0.40"		0.50"		0.60"		0.70"		0.80"		0.90"		1.00"		
CFM	RPM	BHP	RPM	BHP	RPM	BHP	RPM	BHP	RPM	BHP	RPM	BHP	RPM	BHP	RPM	BHP	RPM	BHP	RPM	BHP	RPM	BHP
2720	843	0.34	884	0.41	922	0.48	959	0.55	996	0.62	1031	0.69	1063	0.76	1093	0.83	1121	0.90	1148	0.97		
3060	939	0.47	976	0.54	1011	0.62	1044	0.69	1077	0.77	1110	0.86	1141	0.94	1173	1.02	1200	1.10	1227	1.18		
3400	1035	0.62	1069	0.71	1102	0.79	1133	0.87	1162	0.96	1192	1.05	1221	1.14	1250	1.23	1279	1.32	1306	1.41		
3740	1132	0.81	1163	0.90	1193	0.99	1222	1.08	1250	1.18	1277	1.27	1305	1.37	1331	1.47	1357	1.57	1383	1.67		
4080	1230	1.03	1258	1.13	1286	1.23	1313	1.33	1340	1.43	1365	1.53	1390	1.64	1415	1.74	1439	1.85	1464	1.96		
External Static Pressure (Inches of Water Gauge)																						
		1.10"		1.20"		1.30"		1.40"		1.50"		1.60"		1.70"		1.80"		1.90"		2.00"		
CFM	RPM	BHP	RPM	BHP	RPM	BHP	RPM	BHP	RPM	BHP	RPM	BHP	RPM	BHP	RPM	BHP	RPM	BHP	RPM	BHP	RPM	BHP
2720	1174	1.05	1199	1.12	1223	1.19	1246	1.27	1269	1.34	1293	1.42	1314	1.50	1336	1.57	1357	1.65	1376	1.73		
3060	1252	1.26	1276	1.34	1299	1.41	1322	1.49	1345	1.58	1367	1.66	1387	1.74	1409	1.83	1429	1.91	1448	2.00		
3400	1331	1.50	1355	1.58	1378	1.67	1400	1.76	1422	1.85	1443	1.94	1463	2.03	1483	2.12	1503	2.21	1523	2.30		
3740	1409	1.77	1434	1.87	1457	1.96	1479	2.06	1500	2.15	1520	2.25	1540	2.34	1560	2.44	1580	2.54	1599	2.64		
4080	1488	2.07	1512	2.18	1535	2.29	1559	2.40	1581	2.50	1600	2.60	1620	2.71	1640	2.82	-	-	-	-		

**Notes:**

1. For direct drive evaporator fan speed (rpm), refer to the applicable table in the fan performance section.
2. Data includes pressure drop due to standard filters and wet coils.
3. To determine static pressure drop due to other options/accessories, refer to the applicable table in the fan performance section.
4. Direct drive fan motor heat (MBh) = 2.7912 x fan bhp + 0.1388
5. Factory supplied motors, in commercial equipment, are definite purpose motors, specifically designed and tested to operate reliably and continuously at all cataloged conditions. Using the full horsepower range of our fan motors as shown in our tabular data will not result in nuisance tripping or premature motor failure. Our product's warranty will not be affected.



## Evaporator Fan Performance – Standard Efficiency

**Table 85. Belt drive evaporator fan performance – 8.5 tons standard efficiency with gas heat – YSC102H3,4,W\*H high heat horizontal airflow**

External Static Pressure (Inches of Water Gauge)																						
		0.10"		0.20"		0.30"		0.40"		0.50"		0.60"		0.70"		0.80"		0.90"		1.00"		
CFM	RPM	BHP	RPM	BHP	RPM	BHP	RPM	BHP	RPM	BHP	RPM	BHP	RPM	BHP	RPM	BHP	RPM	BHP	RPM	BHP	RPM	BHP
2-hp Standard Motor & Low Static Drive <sup>(a)</sup>											2-hp Standard Motor & Drive											
2720	593	0.53	639	0.62	679	0.70	719	0.79	754	0.87	788	0.95	821	1.04	853	1.13	883	1.21	913	1.30		
3060	657	0.74	698	0.83	736	0.93	770	1.02	807	1.12	838	1.21	868	1.29	898	1.39	928	1.49	957	1.59		
3400	721	0.99	758	1.09	794	1.20	827	1.30	858	1.41	890	1.52	920	1.62	947	1.71	974	1.81	1002	1.92		
3740	786	1.29	820	1.40	853	1.52	885	1.63	914	1.75	942	1.87	972	1.99	1001	2.11	1025	2.21	1050	2.31		
4080	851	1.65	882	1.77	913	1.90	944	2.03	972	2.15	998	2.28	1024	2.40	1051	2.54	1078	2.67	1102	2.79		
											3-hp Oversized Motor & Drive <sup>(b)</sup>											
External Static Pressure (Inches of Water Gauge)																						
		1.10"		1.20"		1.30"		1.40"		1.50"		1.60"		1.70"		1.80"		1.90"		2.00"		
CFM	RPM	BHP	RPM	BHP	RPM	BHP	RPM	BHP	RPM	BHP	RPM	BHP	RPM	BHP	RPM	BHP	RPM	BHP	RPM	BHP	RPM	BHP
2-hp Standard Motor & Drive											3-hp Oversized Motor & Drive <sup>(c)</sup>											
2720	941	1.39	967	1.48	992	1.56	1018	1.65	1043	1.74	1065	1.83	1088	1.91	1110	2.00	1131	2.08	1152	2.17		
3060	984	1.69	1010	1.79	1035	1.89	1060	1.99	1084	2.09	1107	2.18	1129	2.28	1151	2.38	1173	2.48	1193	2.57		
3400	1028	2.03	1053	2.14	1078	2.25	1103	2.37	1126	2.48	1149	2.58	1172	2.70	1193	2.81	1215	2.92	1234	3.02		
3740	1074	2.42	1099	2.54	1123	2.67	1146	2.79	1170	2.91	1193	3.04	1214	3.16	1235	3.27	1257	3.40	-	-		
4080	1125	2.90	1148	3.01	1170	3.14	1193	3.27	1214	3.40	-	-	-	-	-	-	-	-	-	-		

**Notes:**

1. For standard evaporator fan speed (rpm), reference the standard motor and sheave/fan speed applicable table in the fan performance section.
2. Data includes pressure drop due to standard filters and wet coils. No accessories or options are included in pressure drop data.
3. To determine static pressure drop due to other options/accessories, refer to the applicable table in the fan performance section.
4. 2-hp fan motor heat (MBh) = 2.000 x fan bhp + .5000. 3-hp fan motor heat (MBh) = 2.900 x fan bhp + .4750
5. Factory supplied motors, in commercial equipment, are definite purpose motors, specifically designed and tested to operate reliably and continuously at all cataloged conditions. Using the full horsepower range of our fan motors as shown in our tabular data will not result in nuisance tripping or premature motor failure. Our product's warranty will not be affected.

(a) BAYLSDR009A  
 (b) BAYHSMT097A  
 (c) BAYHSMT097A

## Evaporator Fan Performance — Standard Efficiency

**Table 86. Direct drive evaporator fan performance – 8.5 tons standard efficiency Title 24 single zone VAV – YSC102H3,4,W\*H high gas heat horizontal airflow**

External Static Pressure (Inches of Water Gauge)																						
		0.10"		0.20"		0.30"		0.40"		0.50"		0.60"		0.70"		0.80"		0.90"		1.00"		
CFM	RPM	BHP	RPM	BHP	RPM	BHP	RPM	BHP	RPM	BHP	RPM	BHP	RPM	BHP	RPM	BHP	RPM	BHP	RPM	BHP	RPM	BHP
2720	820	0.30	861	0.37	906	0.44	945	0.50	985	0.58	1022	0.66	1053	0.72	1084	0.79	1116	0.87	1145	0.94		
3060	912	0.41	949	0.48	989	0.56	1026	0.64	1061	0.71	1096	0.80	1130	0.88	1161	0.97	1188	1.04	1217	1.12		
3400	1005	0.55	1039	0.63	1072	0.70	1110	0.79	1142	0.88	1173	0.96	1205	1.05	1237	1.15	1267	1.25	1294	1.34		
3740	1099	0.71	1130	0.80	1160	0.88	1192	0.97	1226	1.07	1255	1.16	1284	1.26	1312	1.35	1341	1.46	1369	1.57		
4080	1193	0.91	1222	1.00	1250	1.09	1277	1.18	1308	1.29	1338	1.39	1366	1.50	1392	1.60	1417	1.70	1443	1.81		
External Static Pressure (Inches of Water Gauge)																						
		1.10"		1.20"		1.30"		1.40"		1.50"		1.60"		1.70"		1.80"		1.90"		2.00"		
CFM	RPM	BHP	RPM	BHP	RPM	BHP	RPM	BHP	RPM	BHP	RPM	BHP	RPM	BHP	RPM	BHP	RPM	BHP	RPM	BHP	RPM	BHP
2720	1174	1.02	1203	1.10	1229	1.17	1255	1.25	1280	1.33	1304	1.41	1328	1.50	1352	1.58	1374	1.66	1397	1.75		
3060	1245	1.20	1272	1.29	1298	1.37	1323	1.46	1348	1.55	1372	1.63	1395	1.72	1417	1.81	1440	1.90	1461	1.99		
3400	1318	1.42	1343	1.51	1368	1.60	1393	1.69	1417	1.79	1440	1.88	1463	1.97	1485	2.07	1508	2.17	1529	2.26		
3740	1396	1.68	1420	1.77	1443	1.86	1465	1.96	1489	2.06	1512	2.16	1534	2.26	1556	2.36	1577	2.46	1598	2.57		
4080	1470	1.93	1497	2.05	1522	2.17	1543	2.27	1564	2.37	1584	2.47	1606	2.58	1626	2.68	1648	2.79	-	-		

**Notes:**

1. For direct drive evaporator fan speed (rpm), refer to the applicable table in the fan performance section.
2. Data includes pressure drop due to standard filters and wet coils.
3. To determine static pressure drop due to other options/accessories, refer to the applicable table in the fan performance section.
4. Direct drive fan motor heat (MBh) = 2.7912 x fan bhp + 0.1388
5. Factory supplied motors, in commercial equipment, are definite purpose motors, specifically designed and tested to operate reliably and continuously at all cataloged conditions. Using the full horsepower range of our fan motors as shown in our tabular data will not result in nuisance tripping or premature motor failure. Our product's warranty will not be affected.



## Evaporator Fan Performance – Standard Efficiency

**Table 87. Direct drive evaporator fan performance – 10 tons standard efficiency – TSC120H3,4,W downflow airflow**

External Static Pressure (Inches of Water Gauge)																						
		0.10"		0.20"		0.30"		0.40"		0.50"		0.60"		0.70"		0.80"		0.90"		1.00"		
CFM	RPM	BHP	RPM	BHP	RPM	BHP	RPM	BHP	RPM	BHP	RPM	BHP	RPM	BHP	RPM	BHP	RPM	BHP	RPM	BHP	RPM	BHP
3200	942	0.47	978	0.54	1017	0.63	1053	0.71	1082	0.78	1116	0.87	1150	0.96	1181	1.04	1207	1.12	1231	1.19		
3600	1051	0.65	1083	0.73	1116	0.81	1152	0.91	1183	1.00	1209	1.08	1237	1.17	1268	1.27	1298	1.38	1325	1.47		
4000	1161	0.87	1190	0.96	1219	1.05	1249	1.15	1282	1.26	1310	1.36	1334	1.45	1357	1.54	1385	1.65	1412	1.76		
4400	1272	1.13	1298	1.23	1324	1.33	1351	1.44	1379	1.54	1409	1.67	1435	1.79	1457	1.88	1478	1.98	1501	2.08		
4800	1383	1.45	1407	1.56	1431	1.66	1455	1.78	1480	1.89	1506	2.01	1532	2.14	1558	2.28	1579	2.39	1599	2.49		
External Static Pressure (Inches of Water Gauge)																						
		1.10"		1.20"		1.30"		1.40"		1.50"		1.60"		1.70"		1.80"		1.90"		2.00"		
CFM	RPM	BHP	RPM	BHP	RPM	BHP	RPM	BHP	RPM	BHP	RPM	BHP	RPM	BHP	RPM	BHP	RPM	BHP	RPM	BHP	RPM	BHP
3200	1254	1.26	1282	1.35	1307	1.43	1332	1.51	1357	1.59	1381	1.66	1404	1.74	1427	1.82	1449	1.89	1471	1.96		
3600	1350	1.56	1372	1.64	1392	1.72	1412	1.80	1437	1.90	1460	1.99	1483	2.08	1504	2.17	1526	2.26	1548	2.35		
4000	1440	1.88	1464	1.98	1488	2.08	1508	2.18	1527	2.26	1545	2.35	1564	2.44	1586	2.55	1606	2.65	1627	2.75		
4400	1526	2.20	1552	2.33	1576	2.46	1600	2.58	1621	2.69	1642	2.80	1660	2.90	-	-	-	-	-	-	-	-
4800	1618	2.60	1639	2.71	1663	2.85	-	-	-	-	-	-	-	-	-	-	-	-	-	-	-	-

**Notes:**

1. For direct drive evaporator fan speed (rpm), refer to the applicable table in the fan performance section.
2. Data includes pressure drop due to standard filters and wet coils. No accessories or options are included in pressure drop data.
3. To determine static pressure drop due to other options/accessories, refer to the applicable table in the fan performance section.
4. Direct drive fan motor heat (MBh) = 2.7912 x fan bhp + 0.1388
5. Factory supplied motors, in commercial equipment, are definite purpose motors, specifically designed and tested to operate reliably and continuously at all cataloged conditions. Using the full horsepower range of our fan motors as shown in our tabular data will not result in nuisance tripping or premature motor failure. Our product's warranty will not be affected.
6. For electric heat applications, minimum airflow is set to 320 cfm/ton, unless specified otherwise, values found in electric heat temperature rise table.

## Evaporator Fan Performance — Standard Efficiency

**Table 88. Direct drive evaporator fan performance – 10 tons standard efficiency – TSC120H3,4,W horizontal airflow**

External Static Pressure (Inches of Water Gauge)																						
		0.10"		0.20"		0.30"		0.40"		0.50"		0.60"		0.70"		0.80"		0.90"		1.00"		
CFM	RPM	BHP	RPM	BHP	RPM	BHP	RPM	BHP	RPM	BHP	RPM	BHP	RPM	BHP	RPM	BHP	RPM	BHP	RPM	BHP	RPM	BHP
3200	953	0.48	988	0.55	1027	0.64	1067	0.73	1098	0.80	1128	0.88	1157	0.96	1186	1.03	1213	1.11	1239	1.19		
3600	1064	0.67	1095	0.75	1126	0.83	1163	0.93	1198	1.03	1226	1.11	1253	1.20	1280	1.29	1306	1.37	1331	1.46		
4000	1175	0.90	1203	0.98	1231	1.07	1260	1.17	1294	1.28	1327	1.39	1353	1.49	1377	1.58	1401	1.68	1425	1.78		
4400	1288	1.18	1313	1.27	1338	1.36	1364	1.46	1392	1.57	1422	1.70	1452	1.82	1477	1.93	1500	2.04	1522	2.14		
4800	1400	1.51	1423	1.61	1446	1.71	1470	1.82	1494	1.93	1519	2.05	1547	2.18	1575	2.32	1600	2.45	1622	2.56		
External Static Pressure (Inches of Water Gauge)																						
		1.10"		1.20"		1.30"		1.40"		1.50"		1.60"		1.70"		1.80"		1.90"		2.00"		
CFM	RPM	BHP	RPM	BHP	RPM	BHP	RPM	BHP	RPM	BHP	RPM	BHP	RPM	BHP	RPM	BHP	RPM	BHP	RPM	BHP	RPM	BHP
3200	1265	1.27	1291	1.35	1316	1.43	1342	1.52	1365	1.60	1389	1.69	1412	1.78	1435	1.87	1458	1.96	1479	2.05		
3600	1355	1.54	1378	1.63	1401	1.72	1425	1.81	1447	1.90	1471	2.00	1492	2.09	1515	2.19	1536	2.28	1557	2.38		
4000	1448	1.87	1471	1.97	1494	2.07	1515	2.16	1536	2.26	1557	2.36	1578	2.46	1598	2.56	1619	2.66	1640	2.77		
4400	1543	2.24	1565	2.35	1586	2.46	1607	2.56	1628	2.67	1647	2.77	1667	2.88	1686	2.98	-	-	-	-		
4800	1642	2.68	1662	2.79	1682	2.91	1701	3.02	-	-	-	-	-	-	-	-	-	-	-	-		

**Notes:**

1. For direct drive evaporator fan speed (rpm), refer to the applicable table in the fan performance section.
2. Data includes pressure drop due to standard filters and wet coils. No accessories or options are included in pressure drop data.
3. To determine static pressure drop due to other options/accessories, refer to the applicable table in the fan performance section.
4. Direct drive fan motor heat (MBh) = 2.7912 x fan bhp + 0.1388
5. Factory supplied motors, in commercial equipment, are definite purpose motors, specifically designed and tested to operate reliably and continuously at all cataloged conditions. Using the full horsepower range of our fan motors as shown in our tabular data will not result in nuisance tripping or premature motor failure. Our product's warranty will not be affected.
6. For electric heat applications, minimum airflow is set to 320 cfm/ton, unless specified otherwise, values found in electric heat temperature rise table.



## Evaporator Fan Performance – Standard Efficiency

**Table 89. Direct drive evaporator fan performance – 10 tons standard efficiency with gas heat – YSC120H3,4,W\*L,M low & medium heat downflow airflow**

External Static Pressure (Inches of Water Gauge)																						
		0.10"		0.20"		0.30"		0.40"		0.50"		0.60"		0.70"		0.80"		0.90"		1.00"		
CFM	RPM	BHP	RPM	BHP	RPM	BHP	RPM	BHP	RPM	BHP	RPM	BHP	RPM	BHP	RPM	BHP	RPM	BHP	RPM	BHP	RPM	BHP
3200	956	0.49	992	0.56	1026	0.64	1060	0.72	1092	0.80	1124	0.88	1157	0.97	1190	1.06	1219	1.14	1244	1.21		
3600	1067	0.67	1100	0.76	1130	0.84	1160	0.93	1190	1.01	1219	1.11	1248	1.20	1276	1.30	1305	1.39	1335	1.49		
4000	1179	0.90	1208	0.99	1237	1.09	1264	1.18	1291	1.28	1318	1.38	1344	1.48	1370	1.58	1395	1.68	1421	1.79		
4400	1291	1.18	1318	1.28	1345	1.39	1370	1.49	1394	1.59	1419	1.69	1443	1.80	1467	1.91	1491	2.02	1514	2.14		
4800	1404	1.51	1428	1.62	1453	1.73	1477	1.85	1500	1.96	1522	2.07	1544	2.18	1567	2.30	1590	2.42	1611	2.54		
External Static Pressure (Inches of Water Gauge)																						
		1.10"		1.20"		1.30"		1.40"		1.50"		1.60"		1.70"		1.80"		1.90"		2.00"		
CFM	RPM	BHP	RPM	BHP	RPM	BHP	RPM	BHP	RPM	BHP	RPM	BHP	RPM	BHP	RPM	BHP	RPM	BHP	RPM	BHP	RPM	BHP
3200	1268	1.29	1296	1.38	1323	1.47	1350	1.56	1376	1.65	1400	1.74	1426	1.84	1450	1.93	1473	2.03	1496	2.13		
3600	1362	1.59	1386	1.68	1407	1.76	1429	1.85	1454	1.95	1479	2.05	1502	2.14	1525	2.25	1548	2.35	1571	2.46		
4000	1448	1.90	1475	2.01	1500	2.12	1523	2.22	1543	2.31	1562	2.41	1581	2.50	1604	2.61	1626	2.72	1647	2.83		
4400	1538	2.25	1561	2.37	1586	2.49	1609	2.61	1634	2.74	1656	2.85	-	-	-	-	-	-	-	-	-	-
4800	1633	2.67	1655	2.79	-	-	-	-	-	-	-	-	-	-	-	-	-	-	-	-	-	-

**Notes:**

1. For direct drive evaporator fan speed (rpm), refer to the applicable table in the fan performance section.
2. Data includes pressure drop due to standard filters and wet coils. No accessories or options are included in pressure drop data.
3. To determine static pressure drop due to other options/accessories, refer to the applicable table in the fan performance section.
4. Direct drive fan motor heat (MBh) = 2.7912 x fan bhp + 0.1388
5. Factory supplied motors, in commercial equipment, are definite purpose motors, specifically designed and tested to operate reliably and continuously at all cataloged conditions. Using the full horsepower range of our fan motors as shown in our tabular data will not result in nuisance tripping or premature motor failure. Our product's warranty will not be affected.



## Evaporator Fan Performance — Standard Efficiency

**Table 90. Direct drive evaporator fan performance – 10 tons standard efficiency with gas heat – YSC120H3,4,W\*L,M low & medium heat horizontal airflow**

External Static Pressure (Inches of Water Gauge)																						
		0.10"		0.20"		0.30"		0.40"		0.50"		0.60"		0.70"		0.80"		0.90"		1.00"		
CFM	RPM	BHP	RPM	BHP	RPM	BHP	RPM	BHP	RPM	BHP	RPM	BHP	RPM	BHP	RPM	BHP	RPM	BHP	RPM	BHP	RPM	BHP
3200	949	0.48	989	0.56	1026	0.63	1061	0.71	1092	0.79	1124	0.88	1155	0.96	1186	1.05	1214	1.13	1241	1.22		
3600	1059	0.66	1094	0.74	1128	0.83	1161	0.92	1192	1.01	1220	1.10	1248	1.19	1276	1.29	1303	1.39	1330	1.48		
4000	1170	0.88	1200	0.97	1233	1.07	1262	1.17	1291	1.27	1320	1.37	1346	1.47	1370	1.57	1395	1.67	1420	1.78		
4400	1282	1.15	1308	1.25	1338	1.36	1366	1.47	1393	1.57	1420	1.68	1445	1.79	1469	1.90	1492	2.01	1514	2.12		
4800	1394	1.48	1417	1.58	1444	1.69	1471	1.82	1496	1.93	1520	2.05	1545	2.17	1569	2.29	1592	2.41	1613	2.52		
External Static Pressure (Inches of Water Gauge)																						
		1.10"		1.20"		1.30"		1.40"		1.50"		1.60"		1.70"		1.80"		1.90"		2.00"		
CFM	RPM	BHP	RPM	BHP	RPM	BHP	RPM	BHP	RPM	BHP	RPM	BHP	RPM	BHP	RPM	BHP	RPM	BHP	RPM	BHP	RPM	BHP
3200	1267	1.30	1292	1.38	1316	1.45	1339	1.52	1362	1.59	1384	1.66	1407	1.73	1428	1.80	1448	1.86	1469	1.92		
3600	1356	1.58	1381	1.67	1404	1.76	1427	1.85	1449	1.94	1471	2.03	1492	2.11	1512	2.19	1533	2.27	1552	2.35		
4000	1445	1.89	1470	2.00	1493	2.11	1517	2.21	1539	2.32	1559	2.42	1580	2.52	1600	2.61	1620	2.71	1639	2.80		
4400	1537	2.24	1560	2.36	1582	2.47	1605	2.60	1627	2.72	1649	2.84	-	-	-	-	-	-	-	-		
4800	1634	2.64	1654	2.76	-	-	-	-	-	-	-	-	-	-	-	-	-	-	-	-		

**Notes:**

1. For direct drive evaporator fan speed (rpm), refer to the applicable table in the fan performance section.
2. Data includes pressure drop due to standard filters and wet coils. No accessories or options are included in pressure drop data.
3. To determine static pressure drop due to other options/accessories, refer to the applicable table in the fan performance section.
4. Direct drive fan motor heat (MBh) = 2.7912 x fan bhp + 0.1388
5. Factory supplied motors, in commercial equipment, are definite purpose motors, specifically designed and tested to operate reliably and continuously at all cataloged conditions. Using the full horsepower range of our fan motors as shown in our tabular data will not result in nuisance tripping or premature motor failure. Our product's warranty will not be affected.



## Evaporator Fan Performance – Standard Efficiency

**Table 91. Direct drive evaporator fan performance – 10 tons standard efficiency with gas heat – YSC120H3,4,W\*H high heat downflow airflow**

External Static Pressure (Inches of Water Gauge)																						
		0.10"		0.20"		0.30"		0.40"		0.50"		0.60"		0.70"		0.80"		0.90"		1.00"		
CFM	RPM	BHP	RPM	BHP	RPM	BHP	RPM	BHP	RPM	BHP	RPM	BHP	RPM	BHP	RPM	BHP	RPM	BHP	RPM	BHP	RPM	BHP
3200	979	0.53	1014	0.61	1048	0.68	1081	0.77	1112	0.85	1143	0.93	1174	1.02	1204	1.10	1233	1.19	1259	1.27		
3600	1092	0.73	1124	0.82	1155	0.91	1185	0.99	1214	1.08	1242	1.18	1270	1.27	1297	1.36	1325	1.47	1351	1.56		
4000	1207	0.98	1236	1.08	1264	1.17	1292	1.27	1319	1.37	1344	1.47	1370	1.57	1394	1.67	1420	1.78	1445	1.89		
4400	1322	1.28	1348	1.39	1374	1.49	1400	1.60	1425	1.71	1449	1.82	1473	1.93	1496	2.04	1519	2.15	1542	2.26		
4800	1437	1.64	1462	1.75	1486	1.87	1509	1.99	1533	2.11	1555	2.22	1578	2.34	1599	2.46	1621	2.58	1642	2.70		
External Static Pressure (Inches of Water Gauge)																						
		1.10"		1.20"		1.30"		1.40"		1.50"		1.60"		1.70"		1.80"		1.90"		2.00"		
CFM	RPM	BHP	RPM	BHP	RPM	BHP	RPM	BHP	RPM	BHP	RPM	BHP	RPM	BHP	RPM	BHP	RPM	BHP	RPM	BHP	RPM	BHP
3200	1284	1.35	1308	1.43	1331	1.51	1354	1.60	1376	1.68	1398	1.77	1419	1.86	1440	1.95	1460	2.03	1480	2.12		
3600	1377	1.65	1402	1.75	1424	1.84	1446	1.93	1467	2.02	1489	2.12	1508	2.21	1529	2.30	1548	2.40	1567	2.49		
4000	1468	2.00	1493	2.10	1517	2.21	1540	2.31	1562	2.42	1581	2.52	1601	2.62	1621	2.72	1639	2.82	1659	2.93		
4400	1565	2.38	1586	2.50	1609	2.62	1631	2.74	1654	2.86	1675	2.97	-	-	-	-	-	-	-	-	-	-
4800	1663	2.82	1684	2.95	-	-	-	-	-	-	-	-	-	-	-	-	-	-	-	-	-	-

**Notes:**

1. For direct drive evaporator fan speed (rpm), refer to the applicable table in the fan performance section.
2. Data includes pressure drop due to standard filters and wet coils. No accessories or options are included in pressure drop data.
3. To determine static pressure drop due to other options/accessories, refer to the applicable table in the fan performance section.
4. Direct drive fan motor heat (MBh) = 2.7912 x fan bhp + 0.1388
5. Factory supplied motors, in commercial equipment, are definite purpose motors, specifically designed and tested to operate reliably and continuously at all cataloged conditions. Using the full horsepower range of our fan motors as shown in our tabular data will not result in nuisance tripping or premature motor failure. Our product's warranty will not be affected.

## Evaporator Fan Performance — Standard Efficiency

**Table 92. Direct drive evaporator fan performance – 10 tons standard efficiency with gas heat – YSC120H3,4,W\*H high heat horizontal airflow**

External Static Pressure (Inches of Water Gauge)																						
		0.10"		0.20"		0.30"		0.40"		0.50"		0.60"		0.70"		0.80"		0.90"		1.00"		
CFM	RPM	BHP	RPM	BHP	RPM	BHP	RPM	BHP	RPM	BHP	RPM	BHP	RPM	BHP	RPM	BHP	RPM	BHP	RPM	BHP	RPM	BHP
3200	950	0.47	986	0.54	1023	0.61	1061	0.70	1094	0.78	1127	0.86	1161	0.95	1193	1.05	1221	1.13	1247	1.20		
3600	1060	0.64	1093	0.72	1124	0.80	1158	0.89	1191	0.99	1222	1.08	1251	1.17	1280	1.26	1310	1.37	1339	1.48		
4000	1171	0.86	1201	0.95	1229	1.04	1256	1.13	1288	1.23	1319	1.34	1346	1.44	1373	1.54	1400	1.64	1425	1.75		
4400	1282	1.13	1309	1.22	1336	1.32	1361	1.42	1387	1.52	1416	1.63	1444	1.75	1469	1.86	1494	1.97	1518	2.08		
4800	1394	1.44	1419	1.55	1444	1.65	1467	1.76	1490	1.87	1514	1.98	1541	2.10	1567	2.23	1591	2.35	1614	2.47		
External Static Pressure (Inches of Water Gauge)																						
		1.10"		1.20"		1.30"		1.40"		1.50"		1.60"		1.70"		1.80"		1.90"		2.00"		
CFM	RPM	BHP	RPM	BHP	RPM	BHP	RPM	BHP	RPM	BHP	RPM	BHP	RPM	BHP	RPM	BHP	RPM	BHP	RPM	BHP	RPM	BHP
3200	1274	1.29	1301	1.38	1326	1.46	1351	1.55	1376	1.64	1400	1.73	1423	1.82	1445	1.91	1468	2.01	1489	2.1		
3600	1364	1.57	1388	1.66	1411	1.75	1435	1.84	1459	1.94	1482	2.04	1505	2.14	1527	2.24	1548	2.34	1570	2.44		
4000	1453	1.87	1479	1.98	1503	2.09	1525	2.19	1546	2.29	1567	2.39	1588	2.5	1610	2.61	1631	2.72	1652	2.82		
4400	1541	2.2	1566	2.32	1591	2.45	1615	2.57	1638	2.7	1659	2.82	-	-	-	-	-	-	-	-		
4800	1636	2.6	1658	2.71	1679	2.84	-	-	-	-	-	-	-	-	-	-	-	-	-	-		

**Notes:**

1. For direct drive evaporator fan speed (rpm), refer to the applicable table in the fan performance section.
2. Data includes pressure drop due to standard filters and wet coils. No accessories or options are included in pressure drop data.
3. To determine static pressure drop due to other options/accessories, refer to the applicable table in the fan performance section.
4. Direct drive fan motor heat (MBh) = 2.7912 x fan bhp + 0.1388
5. Factory supplied motors, in commercial equipment, are definite purpose motors, specifically designed and tested to operate reliably and continuously at all cataloged conditions. Using the full horsepower range of our fan motors as shown in our tabular data will not result in nuisance tripping or premature motor failure. Our product's warranty will not be affected.



# Evaporator Fan Performance – High Efficiency

Table 93. Belt drive evaporator fan performance – 3 tons high efficiency – THC036E3,E4 downflow airflow

External Static Pressure (Inches of Water Gauge)																					
		0.10"		0.20"		0.30"		0.40"		0.50"		0.60"		0.70"		0.80"		0.90"		1.00"	
CFM	RPM	BHP	RPM	BHP	RPM	BHP	RPM	BHP	RPM	BHP	RPM	BHP	RPM	BHP	RPM	BHP	RPM	BHP	RPM	BHP	
1-hp Standard Motor & Low Static Drive Accessory Kit <sup>(a)</sup>											1-hp Standard Motor & Drive										
600*	—	—	468	0.07	547	0.10	616	0.13	677	0.17	729	0.21	776	0.24	819	0.28	860	0.32	898	0.36	
720*	386	0.05	490	0.08	570	0.12	638	0.16	697	0.12	752	0.24	802	0.28	848	0.33	889	0.37	928	0.42	
840*	416	0.06	511	0.10	593	0.14	661	0.19	719	0.23	773	0.28	823	0.32	870	0.37	914	0.42	954	0.47	
960	449	0.08	534	0.12	614	0.17	683	0.22	742	0.27	795	0.32	845	0.37	891	0.42	935	0.47	977	0.53	
1080	483	0.11	561	0.15	635	0.20	704	0.25	765	0.30	818	0.36	868	0.42	913	0.47	957	0.53	998	0.59	
1200	518	0.14	592	0.18	658	0.23	725	0.29	786	0.35	842	0.41	891	0.47	936	0.53	979	0.59	1019	0.66	
1320	555	0.17	625	0.22	686	0.27	747	0.33	807	0.39	862	0.46	914	0.53	959	0.59	1002	0.66	1043	0.73	
1440	592	0.21	658	0.27	717	0.32	772	0.38	828	0.44	882	0.51	933	0.58	980	0.66	1025	0.73	1065	0.80	

External Static Pressure (Inches of Water Gauge)											
		1.10"		1.20"		1.30"		1.40"		1.50"	
CFM	RPM	BHP	RPM	BHP	RPM	BHP	RPM	BHP	RPM	BHP	
1-hp Standard Motor & Drive											
600*	934	0.41	968	0.45	1001	0.49	1034	0.54	1066	0.59	
720*	965	0.46	999	0.51	1032	0.56	1065	0.61	1095	0.66	
840*	992	0.53	1029	0.58	1063	0.63	1096	0.68	1125	0.74	
960	1016	0.59	1054	0.65	1089	0.70	1124	0.76	1155	0.82	
1080	1036	0.65	1075	0.72	1111	0.78	1146	0.84	1180	0.91	
1200	1058	0.72	1095	0.78	1131	0.85	1167	0.92	1201	0.99	
1320	1082	0.80	1119	0.87	1153	0.94	1188	1.01	1221	1.08	
1440	1104	0.88	1141	0.95	1176	1.03	1211	1.10	1243	1.18	
1-hp Std. Motor & Field Supplied High Static Drive <sup>(b)</sup>											

**Notes:**

- For standard evaporator fan speed (rpm), reference the standard motor and sheave/fan speed applicable table in the fan performance section.
- Data includes pressure drop due to standard filters and wet coils. No accessories or options are included in pressure drop data.
- To determine static pressure drop due to other options/accessories, refer to the applicable table in the fan performance section.
- 1-hp fan motor heat (MBh) = 2.7672 x fan bhp + 0.4705.
- Factory supplied motors, in commercial equipment, are definite purpose motors, specifically designed and tested to operate reliably and continuously at all cataloged conditions. Using the full horsepower range of our fan motors as shown in our tabular data will not result in nuisance tripping or premature motor failure. Our product's warranty will not be affected.
- \* For 600, 720, and 840 CFM, unit application below 320 cfm/ton are only applicable on T\_C models only (no gas heat). See below for restrictions.
- \* For electric heat applications, minimum airflow is set to 320 cfm/ton, unless specified otherwise, values found in electric heat temperature rise table.
- \* Dehumidification (hot gas reheat) or TXV with frostat and crankcase heaters are required on applications below 320 cfm/ton

<sup>(a)</sup> BAYLSDR006AB

<sup>(b)</sup> Field supplied fan sheave AK41x3/4" required. Field supplied belt may be necessary.

## Evaporator Fan Performance – High Efficiency

**Table 94. Belt drive evaporator fan performance – 3 tons high efficiency – THC036E3,E4 horizontal airflow**

	External Static Pressure (Inches of Water Gauge)																			
	0.10"		0.20"		0.30"		0.40"		0.50"		0.60"		0.70"		0.80"		0.90"		1.00"	
CFM	RPM	BHP	RPM	BHP	RPM	BHP	RPM	BHP	RPM	BHP	RPM	BHP	RPM	BHP	RPM	BHP	RPM	BHP	RPM	BHP
<b>1-hp Standard Motor &amp; Low Static Drive Accessory Kit<sup>(a)</sup></b>										<b>1-hp Standard Motor &amp; Drive</b>										
600*	372	0.04	472	0.06	552	0.09	619	0.12	678	0.15	730	0.18	778	0.22	823	0.25	865	0.29	904	0.32
720*	398	0.05	496	0.08	575	0.11	643	0.15	702	0.18	756	0.22	805	0.26	849	0.29	892	0.33	931	0.37
840*	422	0.06	524	0.10	598	0.13	665	0.17	726	0.22	780	0.26	829	0.30	875	0.34	918	0.39	957	0.43
960	449	0.08	552	0.12	626	0.16	689	0.20	748	0.25	802	0.30	852	0.35	898	0.39	942	0.44	982	0.49
1080	482	0.10	576	0.14	654	0.19	716	0.24	772	0.29	825	0.34	874	0.39	921	0.45	964	0.50	1005	0.55
1200	517	0.13	600	0.17	681	0.23	744	0.28	799	0.33	850	0.39	898	0.44	943	0.50	987	0.56	1028	0.62
1320	554	0.16	627	0.20	705	0.27	773	0.33	828	0.38	877	0.44	923	0.50	967	0.56	1010	0.62	1052	0.69
1440	590	0.20	657	0.24	728	0.30	797	0.37	855	0.44	904	0.50	950	0.56	993	0.63	1034	0.69	1074	0.76

	External Static Pressure (Inches of Water Gauge)									
	1.10"		1.20"		1.30"		1.40"		1.50"	
CFM	RPM	BHP	RPM	BHP	RPM	BHP	RPM	BHP	RPM	BHP
<b>1-hp Standard Motor &amp; Drive</b>										
600*	941	0.36	977	0.40	1010	0.44	1042	0.48	1074	0.53
720*	969	0.41	1005	0.45	1040	0.50	1073	0.54	1105	0.59
840*	995	0.47	1031	0.52	1066	0.56	1100	0.61	1131	0.66
960	1020	0.54	1057	0.59	1092	0.64	1126	0.69	1158	0.74
1080	1045	0.61	1082	0.67	1116	0.72	1151	0.77	1183	0.83
1200	1067	0.68	1104	0.74	1141	0.80	1174	0.86	1207	0.92
1320	1091	0.75	1127	0.82	1163	0.88	1198	0.95	1230	1.02
1440	1112	0.83	1150	0.90	1186	0.97	1221	1.04	1254	1.11
<b>1-hp Std. Motor &amp; Field Supplied High Static Drive<sup>(b)</sup></b>										

**Notes:**

1. For standard evaporator fan speed (rpm), reference the standard motor and sheave/fan speed applicable table in the fan performance section.
2. Data includes pressure drop due to standard filters and wet coils. No accessories or options are included in pressure drop data.
3. To determine static pressure drop due to other options/accessories, refer to the applicable table in the fan performance section.
4. 1-hp fan motor heat (MBh) = 2.7672 x fan bhp + 0.4705.
5. Factory supplied motors, in commercial equipment, are definite purpose motors, specifically designed and tested to operate reliably and continuously at all cataloged conditions. Using the full horsepower range of our fan motors as shown in our tabular data will not result in nuisance tripping or premature motor failure. Our product's warranty will not be affected.
6. \* For 600, 720, and 840 cfm, unit application below 320 cfm/ton are only applicable on T\_C models only (no gas heat). See below for restrictions.
7. \* For electric heat applications, minimum airflow is set to 320 cfm/ton, unless specified otherwise, values found in electric heat temperature rise table.
8. \* Dehumidification (hot gas reheat) or TXV with frostat and crankcase heaters are required on applications below 320 cfm/ton

<sup>(a)</sup> BAYLSDR006AB

<sup>(b)</sup> Field supplied fan sheave AK41x3/4" required. Field supplied belt may be necessary.



## Evaporator Fan Performance – High Efficiency

**Table 95. Belt drive evaporator fan performance – 3 tons high efficiency – YHC036E3,E4,EW\*L,M low & medium gas heat downflow airflow**

External Static Pressure (Inches of Water Gauge)																					
		0.10"		0.20"		0.30"		0.40"		0.50"		0.60"		0.70"		0.80"		0.90"		1.00"	
CFM	RPM	BHP	RPM	BHP	RPM	BHP	RPM	BHP	RPM	BHP	RPM	BHP	RPM	BHP	RPM	BHP	RPM	BHP	RPM	BHP	
1-hp Standard Motor & Field Supplied Low Static Drive Accessory Kit <sup>(a)</sup>											1-hp Standard Motor & Drive										
960	—	—	—	—	605	0.15	671	0.19	730	0.23	784	0.27	835	0.31	881	0.36	924	0.41	965	0.45	
1080	—	—	563	0.14	630	0.17	693	0.22	751	0.26	804	0.31	854	0.35	901	0.40	946	0.46	986	0.50	
1200	—	—	596	0.17	659	0.21	718	0.25	773	0.30	825	0.35	875	0.40	921	0.45	964	0.51	1005	0.56	
1320	555	0.16	629	0.20	689	0.25	745	0.29	797	0.34	848	0.40	897	0.45	941	0.51	984	0.56	1026	0.62	
1440	593	0.20	663	0.25	721	0.29	775	0.34	824	0.39	873	0.45	919	0.51	963	0.57	1006	0.63	1046	0.69	
External Static Pressure (Inches of Water Gauge)																					
		1.10"		1.20"		1.30"		1.40"		1.50"											
CFM	RPM	BHP	RPM	BHP	RPM	BHP	RPM	BHP	RPM	BHP											
1-hp Standard Motor & Drive																					
960	1004	0.50	1039	0.55	1073	0.59	1105	0.64	1137	0.69											
1080	1025	0.56	1063	0.61	1098	0.66	1132	0.72	1163	0.77											
1200	1046	0.62	1082	0.67	1119	0.73	1153	0.79	1187	0.85											
1320	1064	0.68	1103	0.74	1139	0.80	1174	0.86	1207	0.93											
1440	1085	0.75	1123	0.81	1159	0.88	1193	0.94	—	—											
1-hp Std. Motor & Field Supplied High Static Drive <sup>(b)</sup>																					

**Notes:**

1. For standard evaporator fan speed (rpm), reference the standard motor and sheave/fan speed applicable table in the fan performance section.
2. Data includes pressure drop due to standard filters and wet coils. No accessories or options are included in pressure drop data.
3. To determine static pressure drop due to other options/accessories, refer to the applicable table in the fan performance section.
4. 1-hp fan motor heat (MBh) = 2.7672 x fan bhp + 0.4705.
5. Factory supplied motors, in commercial equipment, are definite purpose motors, specifically designed and tested to operate reliably and continuously at all cataloged conditions. Using the full horsepower range of our fan motors as shown in our tabular data will not result in nuisance tripping or premature motor failure. Our product's warranty will not be affected.

<sup>(a)</sup> BAYLSDR006AB

<sup>(b)</sup> Field supplied fan sheave AK41x3/4" required. Field supplied belt may be necessary.

## Evaporator Fan Performance – High Efficiency

**Table 96. Belt drive evaporator fan performance – 3 tons high efficiency – YHC036E3,E4,EW\*L,M low & medium gas heat horizontal airflow**

External Static Pressure (Inches of Water Gauge)																					
		0.10"		0.20"		0.30"		0.40"		0.50"		0.60"		0.70"		0.80"		0.90"		1.00"	
CFM	RPM	BHP	RPM	BHP	RPM	BHP	RPM	BHP	RPM	BHP	RPM	BHP	RPM	BHP	RPM	BHP	RPM	BHP	RPM	BHP	
<b>1-hp Standard Motor &amp; Field Supplied Low Static Drive<sup>(a)</sup></b>											<b>1-hp Standard Motor &amp; Drive</b>										
960	—	—	—	—	613	0.15	679	0.20	736	0.24	788	0.28	837	0.32	886	0.37	930	0.42	973	0.47	
1080	—	—	561	0.14	636	0.18	702	0.23	761	0.28	812	0.32	860	0.37	904	0.42	947	0.47	991	0.52	
1200	—	—	589	0.16	661	0.21	726	0.26	784	0.31	836	0.37	884	0.42	929	0.47	970	0.52	1011	0.58	
1320	—	—	619	0.20	687	0.25	750	0.30	807	0.36	859	0.41	909	0.47	953	0.53	995	0.59	1034	0.65	
1440	585	0.19	651	0.24	715	0.29	775	0.35	831	0.40	883	0.47	931	0.53	976	0.59	1019	0.66	1058	0.72	
External Static Pressure (Inches of Water Gauge)																					
		1.10"		1.20"		1.30"		1.40"		1.50"											
CFM	RPM	BHP	RPM	BHP	RPM	BHP	RPM	BHP	RPM	BHP											
<b>1-hp Standard Motor &amp; Drive</b>																					
960	1014	0.53	1051	0.58	1087	0.63	1121	0.68	1155	0.74											
1080	1031	0.58	1071	0.64	1108	0.69	1142	0.75	1177	0.81											
1200	1049	0.63	1087	0.69	1124	0.75	1161	0.82	1195	0.88											
1320	1071	0.70	1107	0.76	1143	0.82	1178	0.89	1213	0.96											
1440	1095	0.78	1130	0.84	1166	0.91	1199	0.97	—	—											
<b>1-hp Std. Motor &amp; Field Supplied High Static Drive<sup>(b)</sup></b>																					

**Notes:**

1. For standard evaporator fan speed (rpm), reference the standard motor and sheave/fan speed applicable table in the fan performance section.
2. Data includes pressure drop due to standard filters and wet coils. No accessories or options are included in pressure drop data.
3. To determine static pressure drop due to other options/accessories, refer to the applicable table in the fan performance section.
4. 1-hp fan motor heat (MBh) = 2.7672 x fan bhp + 0.4705.
5. Factory supplied motors, in commercial equipment, are definite purpose motors, specifically designed and tested to operate reliably and continuously at all cataloged conditions. Using the full horsepower range of our fan motors as shown in our tabular data will not result in nuisance tripping or premature motor failure. Our product's warranty will not be affected.

<sup>(a)</sup> Field supplied fan sheave AK71x3/4" required. Field supplied belt may be necessary

<sup>(b)</sup> Field supplied fan sheave AK41x3/4" required. Field supplied belt may be necessary.



## Evaporator Fan Performance – High Efficiency

**Table 97. Belt drive evaporator fan performance – 3 tons high efficiency – YHC036E3,E4,EW\*H high gas heat downflow airflow**

External Static Pressure (Inches of Water Gauge)																						
		0.10"		0.20"		0.30"		0.40"		0.50"		0.60"		0.70"		0.80"		0.90"		1.00"		
CFM	RPM	BHP	RPM	BHP	RPM	BHP	RPM	BHP	RPM	BHP	RPM	BHP	RPM	BHP	RPM	BHP	RPM	BHP	RPM	BHP	RPM	BHP
1-hp Standard Motor & Field Supplied Low Static Drive <sup>(a)</sup>											1-hp Standard Motor & Drive											
960	—	—	—	—	609	0.15	671	0.19	730	0.24	785	0.28	835	0.33	881	0.37	924	0.42	966	0.47		
1080	—	—	572	0.14	638	0.18	697	0.23	752	0.27	805	0.32	855	0.37	900	0.42	945	0.47	986	0.53		
1200	—	—	606	0.18	668	0.22	725	0.26	778	0.31	827	0.36	876	0.42	922	0.47	964	0.52	1007	0.58		
1320	573	0.17	641	0.22	700	0.26	754	0.31	805	0.36	853	0.41	898	0.47	942	0.53	985	0.59	1026	0.65		
1440	613	0.21	677	0.27	733	0.31	786	0.36	835	0.42	881	0.47	925	0.53	966	0.59	1007	0.65	1047	0.71		
External Static Pressure (Inches of Water Gauge)																						
		1.10"		1.20"		1.30"		1.40"		1.50"												
CFM	RPM	BHP	RPM	BHP	RPM	BHP	RPM	BHP	RPM	BHP												
1-hp Standard Motor & Drive																						
960	1004	0.52	1041	0.58	1076	0.63	1109	0.68	1142	0.73												
1080	1026	0.58	1063	0.64	1098	0.69	1133	0.75	1165	0.81												
1200	1046	0.64	1083	0.70	1120	0.76	1154	0.82	1187	0.88												
1320	1065	0.71	1103	0.77	1139	0.83	1175	0.9	1207	0.96												
1440	1086	0.78	1123	0.84	1160	0.91	1194	0.98	1227	1.05												
1-hp Std. Motor & Field Supplied High Static Drive <sup>(b)</sup>																						

**Notes:**

- For standard evaporator fan speed (rpm), reference the standard motor and sheave/fan speed applicable table in the fan performance section.
- Data includes pressure drop due to standard filters and wet coils. No accessories or options are included in pressure drop data.
- To determine static pressure drop due to other options/accessories, refer to the applicable table in the fan performance section.
- 1-hp fan motor heat (MBh) = 2.7672 x fan bhp + 0.4705.
- Factory supplied motors, in commercial equipment, are definite purpose motors, specifically designed and tested to operate reliably and continuously at all cataloged conditions. Using the full horsepower range of our fan motors as shown in our tabular data will not result in nuisance tripping or premature motor failure. Our product's warranty will not be affected.

<sup>(a)</sup> Field supplied fan sheave AK71x3/4" required. Field supplied belt may be necessary

<sup>(b)</sup> Field supplied fan sheave AK41x3/4" required. Field supplied belt may be necessary.



## Evaporator Fan Performance – High Efficiency

**Table 98. Belt drive evaporator fan performance – 3 tons high efficiency – YHC036E3,E4,EW\*H high gas heat horizontal airflow**

External Static Pressure (Inches of Water Gauge)																								
		0.10"		0.20"		0.30"		0.40"		0.50"		0.60"		0.70"		0.80"		0.90"		1.00"				
CFM	RPM	BHP	RPM	BHP	RPM	BHP	RPM	BHP	RPM	BHP	RPM	BHP	RPM	BHP	RPM	BHP	RPM	BHP	RPM	BHP	RPM	BHP		
1-hp Standard Motor & Field Supplied Low Static Drive <sup>(a)</sup>												1-hp Standard Motor & Drive												
960	—	—	—	—	621	0.15	685	0.20	745	0.24	799	0.29	849	0.33	894	0.38	936	0.42	975	0.47				
1080	—	—	580	0.14	649	0.19	711	0.23	768	0.28	821	0.32	871	0.38	917	0.43	960	0.48	1000	0.53				
1200	—	—	613	0.18	679	0.22	738	0.27	793	0.32	845	0.37	892	0.42	939	0.48	982	0.53	1024	0.59				
1320	574	0.17	647	0.22	710	0.26	767	0.31	820	0.37	870	0.42	917	0.48	962	0.53	1004	0.59	1046	0.66				
1440	612	0.21	682	0.26	742	0.31	797	0.37	849	0.42	897	0.48	943	0.54	986	0.60	1028	0.66	1068	0.72				
External Static Pressure (Inches of Water Gauge)																								
		1.10"		1.20"		1.30"		1.40"		1.50"														
CFM	RPM	BHP	RPM	BHP	RPM	BHP	RPM	BHP	RPM	BHP	RPM	BHP												
1-hp Standard Motor & Drive																								
960	1012	0.52	1048	0.57	1082	0.62	1116	0.67	1148	0.72														
1080	1039	0.59	1075	0.64	1109	0.69	1142	0.74	1173	0.80														
1200	1063	0.65	1100	0.71	1134	0.77	1168	0.83	1199	0.88														
1320	1085	0.72	1122	0.78	1159	0.85	1193	0.91	1226	0.98														
1440	1107	0.79	1145	0.86	1181	0.93	1216	1.00	1248	1.07														
1-hp Std. Motor & Field Supplied High Static Drive <sup>(b)</sup>																								

**Notes:**

1. For standard evaporator fan speed (rpm), reference the standard motor and sheave/fan speed applicable table in the fan performance section.
2. Data includes pressure drop due to standard filters and wet coils. No accessories or options are included in pressure drop data.
3. To determine static pressure drop due to other options/accessories, refer to the applicable table in the fan performance section.
4. 1-hp fan motor heat (MBh) = 2.7672 x fan bhp + 0.4705.
5. Factory supplied motors, in commercial equipment, are definite purpose motors, specifically designed and tested to operate reliably and continuously at all cataloged conditions. Using the full horsepower range of our fan motors as shown in our tabular data will not result in nuisance tripping or premature motor failure. Our product's warranty will not be affected.

<sup>(a)</sup> Field supplied fan sheave AK71x3/4" required. Field supplied belt may be necessary  
<sup>(b)</sup> Field supplied fan sheave AK41x3/4" required. Field supplied belt may be necessary.



## Evaporator Fan Performance – High Efficiency

**Table 99. Belt drive evaporator fan performance – 4 tons high efficiency – THC048E3,E4,EW, F3, F4, FW downflow airflow**

External Static Pressure (Inches of Water Gauge)																					
		0.10"		0.20"		0.30"		0.40"		0.50"		0.60"		0.70"		0.80"		0.90"		1.00"	
CFM	RPM	BHP	RPM	BHP	RPM	BHP	RPM	BHP	RPM	BHP	RPM	BHP	RPM	BHP	RPM	BHP	RPM	BHP	RPM	BHP	
<b>1-hp Standard Motor &amp; Low Static Drive Accessory Kit<sup>(a)</sup></b>											<b>1-hp Standard Motor &amp; Drive</b>										
800*	—	—	444	0.06	526	0.09	598	0.13	663	0.16	720	0.20	772	0.24	820	0.28	863	0.32	905	0.36	
960*	—	—	462	0.08	542	0.12	610	0.15	672	0.19	731	0.23	785	0.27	835	0.32	881	0.36	923	0.41	
1120*	399	0.07	485	0.11	559	0.14	626	0.18	687	0.22	743	0.26	795	0.31	846	0.36	893	0.41	937	0.46	
1280	429	0.10	510	0.14	581	0.17	644	0.21	703	0.26	757	0.30	809	0.35	857	0.40	903	0.45	947	0.51	
1440	459	0.12	537	0.17	604	0.21	665	0.26	722	0.30	774	0.35	823	0.40	871	0.45	916	0.51	959	0.56	
1600	492	0.16	567	0.21	630	0.26	689	0.31	742	0.36	793	0.41	842	0.46	887	0.51	932	0.57	974	0.63	
1760	526	0.20	597	0.26	658	0.31	713	0.36	765	0.42	814	0.47	860	0.53	905	0.58	947	0.64	989	0.70	
1920	561	0.25	627	0.31	687	0.37	739	0.43	790	0.49	838	0.55	882	0.60	924	0.66	966	0.72	1006	0.79	
External Static Pressure (Inches of Water Gauge)																					
		1.10"		1.20"		1.30"		1.40"		1.50"											
CFM	RPM	BHP	RPM	BHP	RPM	BHP	RPM	BHP	RPM	BHP											
<b>1-hp Standard Motor &amp; Drive</b>																					
800*	942	0.40	980	0.44	1015	0.48	1047	0.53	1079	0.57											
960*	964	0.46	1002	0.50	1038	0.55	1072	0.60	1105	0.65											
1120*	979	0.51	1019	0.56	1055	0.62	1091	0.67	1125	0.73											
1280	990	0.56	1031	0.62	1069	0.68	1105	0.74	1140	0.80											
1440	999	0.62	1040	0.68	1079	0.75	1115	0.81	1152	0.87											
1600	1014	0.69	1051	0.75	1089	0.82	1125	0.88	1162	0.95											
1760	1028	0.77	1066	0.83	1104	0.90	1139	0.96	1175	1.04											
1920	1044	0.85	1083	0.92	1118	0.99	1155	1.06	1188	1.13											
<b>1-hp Std. Motor &amp; Field Supplied High Static Drive<sup>(b)</sup></b>																					

**Notes:**

- For standard evaporator fan speed (rpm), reference the standard motor and sheave/fan speed applicable table in the fan performance section.
- Data includes pressure drop due to standard filters and wet coils. No accessories or options are included in pressure drop data.
- To determine static pressure drop due to other options/accessories, refer to the applicable table in the fan performance section.
- 1-hp fan motor heat (MBh) = 2.7672 x fan bhp + 0.4705.
- Factory supplied motors, in commercial equipment, are definite purpose motors, specifically designed and tested to operate reliably and continuously at all cataloged conditions. Using the full horsepower range of our fan motors as shown in our tabular data will not result in nuisance tripping or premature motor failure. Our product's warranty will not be affected.
- \* For 800, 960, and 1120 cfm, unit application below 320 cfm/ton are only applicable on T\_C models only (no gas heat). See below for restrictions.
- \* For electric heat applications, minimum airflow is set to 320 cfm/ton, unless specified otherwise, values found in electric heat temperature rise table.
- \* Dehumidification (hot gas reheat) or TXV with frostat and crankcase heaters are required on applications below 320 cfm/ton

<sup>(a)</sup> BAYLSDR006AB

<sup>(b)</sup> Field supplied fan sheave AK41x3/4" required. Field supplied belt may be necessary.

## Evaporator Fan Performance – High Efficiency

**Table 100. Belt drive evaporator fan performance – 4 tons high efficiency – THC048E3,E4,EW, F3, F4, FW horizontal airflow**

External Static Pressure (Inches of Water Gauge)																					
		0.10"		0.20"		0.30"		0.40"		0.50"		0.60"		0.70"		0.80"		0.90"		1.00"	
CFM	RPM	BHP	RPM	BHP	RPM	BHP	RPM	BHP	RPM	BHP	RPM	BHP	RPM	BHP	RPM	BHP	RPM	BHP	RPM	BHP	
<b>1-hp Standard Motor &amp; Low Static Drive Accessory Kit<sup>(a)</sup></b>											<b>1-hp Standard Motor &amp; Drive</b>										
800*	368	0.05	481	0.08	562	0.12	623	0.16	677	0.20	730	0.24	780	0.28	825	0.32	870	0.37	911	0.41	
960*	392	0.06	501	0.10	587	0.15	655	0.20	711	0.24	759	0.29	804	0.33	848	0.38	891	0.43	932	0.48	
1120*	420	0.08	519	0.13	607	0.18	679	0.23	740	0.29	792	0.34	837	0.39	879	0.45	918	0.50	955	0.55	
1280	449	0.11	541	0.16	625	0.21	700	0.27	764	0.33	819	0.40	868	0.46	912	0.52	951	0.58	989	0.64	
1440	482	0.14	567	0.19	644	0.25	718	0.32	783	0.38	841	0.45	892	0.52	939	0.59	982	0.66	1022	0.73	
1600	518	0.18	596	0.24	668	0.30	736	0.36	801	0.44	861	0.51	915	0.59	963	0.67	1007	0.74	1048	0.82	
1760	555	0.23	625	0.29	694	0.35	757	0.42	820	0.50	879	0.58	933	0.66	984	0.74	1030	0.83	1072	0.91	
1920	593	0.28	657	0.35	723	0.42	783	0.49	840	0.57	897	0.65	951	0.74	1001	0.83	1049	0.92	1093	1.01	
<b>1-hp Std. Motor &amp; Field Supplied High Static Drive<sup>(b)</sup></b>																					
External Static Pressure (Inches of Water Gauge)																					
		1.10"		1.20"		1.30"		1.40"		1.50"											
CFM	RPM	BHP	RPM	BHP	RPM	BHP	RPM	BHP	RPM	BHP											
<b>1-hp Standard Motor &amp; Drive</b>																					
800*	950	0.46	986	0.51	1024	0.56	1057	0.60	1090	0.65											
960*	972	0.53	1009	0.58	1045	0.64	1080	0.69	1111	0.74											
1120*	994	0.61	1031	0.67	1067	0.73	1101	0.79	1134	0.85											
1280	1023	0.70	1057	0.76	1090	0.82	1123	0.89	1157	0.95											
1440	1057	0.80	1091	0.86	1123	0.93	1155	1.00	1184	1.07											
1600	1087	0.90	1123	0.97	1156	1.05	1187	1.12	1217	1.20											
1760	1113	1.00	1150	1.08	1184	1.17	1219	1.25	1250	1.34											
1920	1135	1.10	1174	1.19	1210	1.29	1244	1.38	1278	1.47											
<b>1-hp Std. Motor &amp; Field Supplied High Static Drive<sup>(c)</sup></b>																					

**Notes:**

1. For standard evaporator fan speed (rpm), reference the standard motor and sheave/fan speed applicable table in the fan performance section.
2. Data includes pressure drop due to standard filters and wet coils. No accessories or options are included in pressure drop data.
3. To determine static pressure drop due to other options/accessories, refer to the applicable table in the fan performance section.
4. 1-hp fan motor heat (MBh) = 2.7672 x fan bhp + 0.4705.
5. Factory supplied motors, in commercial equipment, are definite purpose motors, specifically designed and tested to operate reliably and continuously at all cataloged conditions. Using the full horsepower range of our fan motors as shown in our tabular data will not result in nuisance tripping or premature motor failure. Our product's warranty will not be affected.
6. \* For 800, 960, and 1120 cfm, unit application below 320 cfm/ton are only applicable on T\_C models only (no gas heat). See below for restrictions.
7. \* For electric heat applications, minimum airflow is set to 320 cfm/ton, unless specified otherwise, values found in electric heat temperature rise table.
8. \* Dehumidification (hot gas reheat) or TXV with frostat and crankcase heaters are required on applications below 320 cfm/ton

<sup>(a)</sup> BAYLSDR006AB

<sup>(b)</sup> Field supplied fan sheave AK41x3/4" required. Field supplied belt may be necessary.

<sup>(c)</sup> Field supplied fan sheave AK41x3/4" required. Field supplied belt may be necessary.



## Evaporator Fan Performance – High Efficiency

**Table 101. Belt drive evaporator fan performance – 4 tons high efficiency – YHC048E3,E4,EW,F3,F4,FW\*L,M low & medium gas heat downflow airflow**

External Static Pressure (Inches of Water Gauge)																						
		0.10"		0.20"		0.30"		0.40"		0.50"		0.60"		0.70"		0.80"		0.90"		1.00"		
CFM	RPM	BHP	RPM	BHP	RPM	BHP	RPM	BHP	RPM	BHP	RPM	BHP	RPM	BHP	RPM	BHP	RPM	BHP	RPM	BHP		
<b>1-hp Standard Motor &amp; Field Supplied Low Static Drive<sup>(a)</sup></b>														<b>1-hp Standard Motor &amp; Drive</b>								
1280	—	—	—	—	589	0.18	652	0.23	710	0.27	763	0.32	812	0.37	858	0.42	905	0.47	949	0.53		
1440	—	—	546	0.18	614	0.22	675	0.27	731	0.32	782	0.37	830	0.42	876	0.48	919	0.53	961	0.59		
1600	—	—	575	0.22	641	0.27	699	0.32	752	0.37	803	0.43	851	0.49	895	0.54	938	0.60	978	0.66		
1760	538	0.21	606	0.27	668	0.32	725	0.38	776	0.44	826	0.50	872	0.56	916	0.62	958	0.68	997	0.75		
1920	574	0.27	638	0.32	696	0.38	752	0.45	802	0.51	850	0.57	895	0.63	938	0.70	978	0.77	1018	0.84		
														<b>1-hp Std. Motor &amp; Field Supplied High Static Drive<sup>(b)</sup></b>								
External Static Pressure (Inches of Water Gauge)																						
		1.10"		1.20"		1.30"		1.40"		1.50"												
CFM	RPM	BHP	RPM	BHP	RPM	BHP	RPM	BHP	RPM	BHP	RPM	BHP										
<b>1-hp Standard Motor &amp; Drive</b>																						
1280	993	0.58	1032	0.64	1070	0.70	1107	0.76	1143	0.82												
1440	1003	0.65	1043	0.71	1082	0.77	1118	0.84	1154	0.90												
1600	1017	0.72	1054	0.78	1092	0.85	1129	0.92	1165	0.98												
1760	1036	0.81	1073	0.88	1108	0.94	1142	1.01	1177	1.08												
1920	1056	0.91	1092	0.98	1127	1.04	1160	1.11	1193	1.19												
<b>1-hp Std. Motor &amp; Field Supplied High Static Drive<sup>(c)</sup></b>																						

**Notes:**

1. For standard evaporator fan speed (rpm), reference the standard motor and sheave/fan speed applicable table in the fan performance section.
2. Data includes pressure drop due to standard filters and wet coils. No accessories or options are included in pressure drop data.
3. To determine static pressure drop due to other options/accessories, refer to the applicable table in the fan performance section.
4. 1-hp fan motor heat (MBh) = 2.7672 x fan bhp + 0.4705.
5. Factory supplied motors, in commercial equipment, are definite purpose motors, specifically designed and tested to operate reliably and continuously at all cataloged conditions. Using the full horsepower range of our fan motors as shown in our tabular data will not result in nuisance tripping or premature motor failure. Our product's warranty will not be affected.

(a) Field supplied fan sheave AK74x3/4" required. Field supplied belt may be necessary.

(b) Field supplied fan sheave AK41x3/4" required. Field supplied belt may be necessary.

(c) Field supplied fan sheave AK41x3/4" required. Field supplied belt may be necessary.

## Evaporator Fan Performance – High Efficiency

**Table 102. Belt drive evaporator fan performance – 4 tons high efficiency – YHC048E3,E4,EW,F3,F4,FW\*L,M low & medium gas heat horizontal airflow**

External Static Pressure (Inches of Water Gauge)																					
		0.10"		0.20"		0.30"		0.40"		0.50"		0.60"		0.70"		0.80"		0.90"		1.00"	
CFM	RPM	BHP	RPM	BHP	RPM	BHP	RPM	BHP	RPM	BHP	RPM	BHP	RPM	BHP	RPM	BHP	RPM	BHP	RPM	BHP	
<b>1-hp Standard Motor &amp; Field Supplied Low Static Drive<sup>(a)</sup></b>											<b>1-hp Standard Motor &amp; Drive</b>										
1280	—	—	554	0.16	622	0.21	685	0.26	741	0.31	794	0.36	842	0.42	888	0.47	931	0.53	973	0.59	
1440	—	—	590	0.21	652	0.26	712	0.31	767	0.36	818	0.42	866	0.48	911	0.54	953	0.60	995	0.67	
1600	561	0.21	628	0.26	686	0.32	741	0.37	794	0.43	844	0.49	890	0.55	935	0.62	976	0.68	1017	0.75	
1760	602	0.27	667	0.33	722	0.38	773	0.44	822	0.50	871	0.57	917	0.63	960	0.70	1001	0.77	1040	0.84	
1920	644	0.33	706	0.40	760	0.46	809	0.52	855	0.59	900	0.66	944	0.73	987	0.80	1027	0.87	1066	0.95	
External Static Pressure (Inches of Water Gauge)																					
		1.10"		1.20"		1.30"		1.40"		1.50"											
CFM	RPM	BHP	RPM	BHP	RPM	BHP	RPM	BHP	RPM	BHP											
<b>1-hp Standard Motor &amp; Drive</b>																					
1280	1012	0.65	1052	0.72	1090	0.78	1127	0.84	1162	0.91											
1440	1032	0.73	1070	0.80	1107	0.87	1142	0.94	1175	1.01											
1600	1055	0.82	1093	0.89	1128	0.96	1162	1.03	1195	1.11											
1760	1078	0.91	1114	0.99	1150	1.06	1183	1.14	1217	1.22											
1920	1103	1.02	1139	1.10	1174	1.18	1207	1.26	1239	1.34											
<b>1-hp Std. Motor &amp; Field Supplied High Static Drive<sup>(b)</sup></b>																					

**Notes:**

1. For standard evaporator fan speed (rpm), reference the standard motor and sheave/fan speed applicable table in the fan performance section.
2. Data includes pressure drop due to standard filters and wet coils. No accessories or options are included in pressure drop data.
3. To determine static pressure drop due to other options/accessories, refer to the applicable table in the fan performance section.
4. 1-hp fan motor heat (MBh) = 2.7672 x fan bhp + 0.4705.
5. Factory supplied motors, in commercial equipment, are definite purpose motors, specifically designed and tested to operate reliably and continuously at all cataloged conditions. Using the full horsepower range of our fan motors as shown in our tabular data will not result in nuisance tripping or premature motor failure. Our product's warranty will not be affected.

<sup>(a)</sup> Field supplied fan sheave AK74x3/4" required. Field supplied belt may be necessary.

<sup>(b)</sup> Field supplied fan sheave AK41x3/4" required. Field supplied belt may be necessary.



## Evaporator Fan Performance – High Efficiency

**Table 103. Belt drive evaporator fan performance – 4 tons high efficiency – YHC048E3,E4,F3,EW,F4,FW\*H high gas heat downflow airflow**

External Static Pressure (Inches of Water Gauge)																					
		0.10"		0.20"		0.30"		0.40"		0.50"		0.60"		0.70"		0.80"		0.90"		1.00"	
CFM	RPM	BHP	RPM	BHP	RPM	BHP	RPM	BHP	RPM	BHP	RPM	BHP	RPM	BHP	RPM	BHP	RPM	BHP	RPM	BHP	
<b>1-hp Standard Motor &amp; Field Supplied Low Static Drive<sup>(a)</sup></b>											<b>1-hp Standard Motor &amp; Drive</b>										
1280	—	—	528	0.15	600	0.19	661	0.23	717	0.28	771	0.33	821	0.38	870	0.43	915	0.48	959	0.54	
1440	—	—	556	0.18	626	0.23	687	0.28	740	0.33	790	0.38	839	0.43	886	0.49	930	0.54	974	0.61	
1600	—	—	586	0.22	651	0.28	712	0.34	766	0.39	814	0.44	860	0.50	904	0.55	947	0.61	990	0.68	
1760	554	0.22	619	0.28	680	0.33	738	0.39	792	0.46	841	0.52	884	0.58	926	0.63	967	0.69	1007	0.76	
1920	592	0.28	653	0.34	710	0.39	765	0.46	817	0.53	866	0.60	912	0.67	953	0.73	992	0.79	1028	0.85	
External Static Pressure (Inches of Water Gauge)																					
		1.10"		1.20"		1.30"		1.40"		1.50"											
CFM	RPM	BHP	RPM	BHP	RPM	BHP	RPM	BHP	RPM	BHP											
<b>1-hp Standard Motor &amp; Drive</b>																					
1280	1003	0.60	1045	0.66	1083	0.71	1121	0.77	1156	0.83											
1440	1013	0.66	1054	0.73	1094	0.79	1132	0.86	1168	0.92											
1600	1029	0.74	1069	0.81	1106	0.87	1142	0.94	1177	1.01											
1760	1046	0.82	1084	0.89	1121	0.96	1156	1.03	1191	1.11											
1920	1066	0.92	1103	0.99	1139	1.06	1174	1.14	1206	1.21											
<b>1-hp Std. Motor &amp; Field Supplied High Static Drive<sup>(b)</sup></b>																					

**Notes:**

- For standard evaporator fan speed (rpm), reference the standard motor and sheave/fan speed applicable table in the fan performance section.
- Data includes pressure drop due to standard filters and wet coils. No accessories or options are included in pressure drop data.
- To determine static pressure drop due to other options/accessories, refer to the applicable table in the fan performance section.
- 1-hp fan motor heat (MBh) = 2.7672 x fan bhp + 0.4705.
- Factory supplied motors, in commercial equipment, are definite purpose motors, specifically designed and tested to operate reliably and continuously at all cataloged conditions. Using the full horsepower range of our fan motors as shown in our tabular data will not result in nuisance tripping or premature motor failure. Our product's warranty will not be affected.

<sup>(a)</sup> Field supplied fan sheave AK74x3/4" required. Field supplied belt may be necessary.

<sup>(b)</sup> Field supplied fan sheave AK41x3/4" required. Field supplied belt may be necessary.

## Evaporator Fan Performance – High Efficiency

**Table 104. Belt drive evaporator fan performance – 4 tons high efficiency – YHC048E3,E4,EW,F3,F4,FW\*H high gas heat horizontal airflow**

External Static Pressure (Inches of Water Gauge)																					
		0.10"		0.20"		0.30"		0.40"		0.50"		0.60"		0.70"		0.80"		0.90"		1.00"	
CFM	RPM	BHP	RPM	BHP	RPM	BHP	RPM	BHP	RPM	BHP	RPM	BHP	RPM	BHP	RPM	BHP	RPM	BHP	RPM	BHP	
<b>1-hp Standard Motor &amp; Field Supplied Low Static Drive<sup>(a)</sup></b>											<b>1-hp Standard Motor &amp; Drive</b>										
1280	—	—	561	0.16	626	0.20	684	0.25	739	0.29	792	0.34	842	0.39	890	0.45	935	0.50	977	0.56	
1440	—	—	595	0.20	659	0.25	715	0.30	766	0.35	816	0.40	864	0.45	909	0.51	953	0.57	995	0.63	
1600	561	0.20	628	0.25	694	0.31	748	0.36	798	0.41	843	0.47	888	0.52	932	0.58	974	0.64	1015	0.71	
1760	603	0.26	665	0.31	727	0.37	782	0.43	830	0.49	875	0.54	917	0.60	958	0.67	998	0.73	1038	0.80	
1920	646	0.32	705	0.38	761	0.44	816	0.52	864	0.58	908	0.63	949	0.70	988	0.76	1026	0.83	1063	0.90	
External Static Pressure (Inches of Water Gauge)																					
		1.10"		1.20"		1.30"		1.40"		1.50"											
CFM	RPM	BHP	RPM	BHP	RPM	BHP	RPM	BHP	RPM	BHP											
<b>1-hp Standard Motor &amp; Drive</b>																					
1280	1018	0.62	1058	0.68	1095	0.74	1131	0.81	1166	0.87											
1440	1036	0.69	1075	0.76	1113	0.82	1148	0.89	1183	0.96											
1600	1055	0.77	1093	0.84	1130	0.91	1166	0.98	1201	1.05											
1760	1075	0.86	1113	0.93	1149	1.00	1184	1.08	1219	1.15											
1920	1100	0.97	1135	1.04	1171	1.11	1204	1.19	1237	1.26											
<b>1-hp Std. Motor &amp; Field Supplied High Static Drive<sup>(b)</sup></b>																					

**Notes:**

1. For standard evaporator fan speed (rpm), reference the standard motor and sheave/fan speed applicable table in the fan performance section.
2. Data includes pressure drop due to standard filters and wet coils. No accessories or options are included in pressure drop data.
3. To determine static pressure drop due to other options/accessories, refer to the applicable table in the fan performance section.
4. 1-hp fan motor heat (MBh) = 2.7672 x fan bhp + 0.4705.
5. Factory supplied motors, in commercial equipment, are definite purpose motors, specifically designed and tested to operate reliably and continuously at all cataloged conditions. Using the full horsepower range of our fan motors as shown in our tabular data will not result in nuisance tripping or premature motor failure. Our product's warranty will not be affected.

<sup>(a)</sup> Field supplied fan sheave AK74x3/4" required. Field supplied belt may be necessary.

<sup>(b)</sup> Field supplied fan sheave AK41x3/4" required. Field supplied belt may be necessary.



## Evaporator Fan Performance – High Efficiency

**Table 105. Belt drive evaporator fan performance – 5 tons high efficiency – THC060E3,E4,EW,F3,F4,FW downflow airflow**

External Static Pressure (Inches of Water Gauge)																								
		0.10"		0.20"		0.30"		0.40"		0.50"		0.60"		0.70"		0.80"		0.90"		1.00"				
CFM	RPM	BHP	RPM	BHP	RPM	BHP	RPM	BHP	RPM	BHP	RPM	BHP	RPM	BHP	RPM	BHP	RPM	BHP	RPM	BHP	RPM	BHP		
1-hp Standard Motor & Low Static Drive Accessory Kit <sup>(a)</sup>														1-hp Standard Motor & Drive										
1000*	379	0.06	469	0.09	546	0.12	614	0.16	676	0.20	732	0.24	784	0.28	833	0.33	879	0.37	922	0.42				
1200*	416	0.09	498	0.12	571	0.16	635	0.20	694	0.24	749	0.28	800	0.33	849	0.38	894	0.43	938	0.48				
1400*	456	0.12	531	0.16	599	0.20	662	0.25	717	0.29	769	0.34	820	0.39	867	0.44	911	0.50	955	0.56				
1600	499	0.16	570	0.21	631	0.25	691	0.31	745	0.36	794	0.41	842	0.46	887	0.52	930	0.57	972	0.63				
1800	544	0.22	609	0.27	667	0.32	721	0.37	773	0.43	823	0.49	868	0.55	911	0.61	953	0.67	992	0.73				
2000	589	0.29	650	0.35	706	0.40	755	0.46	804	0.52	851	0.58	897	0.65	938	0.71	978	0.77	1017	0.84				
2200	636	0.37	692	0.43	745	0.50	793	0.56	838	0.62	882	0.68	925	0.75	967	0.83	1007	0.90	1044	0.97				
2400	683	0.47	736	0.54	785	0.61	833	0.68	875	0.74	916	0.81	956	0.88	996	0.95	1036	1.03	1073	1.11				
External Static Pressure (Inches of Water Gauge)																								
		1.10"		1.20"		1.30"		1.40"		1.50"														
CFM	RPM	BHP	RPM	BHP	RPM	BHP	RPM	BHP	RPM	BHP	RPM	BHP												
1-hp Standard Motor & Drive																								
1000*	962	0.46	1002	0.51	1040	0.56	1076	0.61	1111	0.66														
1200*	979	0.54	1018	0.50	1055	0.64	1091	0.70	1126	0.75														
1400*	996	0.61	1035	0.67	1072	0.73	1107	0.79	1143	0.85														
1600	1013	0.70	1051	0.76	1088	0.82	1124	0.89	1160	0.96														
1800	1031	0.79	1070	0.86	1106	0.93	1142	1.00	1176	1.07														
2000	1054	0.91	1091	0.98	1126	1.04	1161	1.12	1195	1.19														
2200	1080	1.04	1115	1.11	1148	1.18	1183	1.26	1215	1.33														
2400	1108	1.19	1142	1.27	1176	1.34	1207	1.42	1238	1.49														
1-hp Std. Motor & Field Supplied High Static Drive <sup>(b)</sup>																								

**Notes:**

- For standard evaporator fan speed (rpm), reference the standard motor and sheave/fan speed applicable table in the fan performance section.
- Data includes pressure drop due to standard filters and wet coils. No accessories or options are included in pressure drop data.
- To determine static pressure drop due to other options/accessories, refer to the applicable table in the fan performance section.
- 1-hp fan motor heat (MBh) = 2.7672 x fan bhp + 0.4705.
- Factory supplied motors, in commercial equipment, are definite purpose motors, specifically designed and tested to operate reliably and continuously at all cataloged conditions. Using the full horsepower range of our fan motors as shown in our tabular data will not result in nuisance tripping or premature motor failure. Our product's warranty will not be affected.
- \* For 1000, 1200, and 1400 cfm, unit application below 320 cfm/ton are only applicable on T\_C models only (no gas heat). See below for restrictions.
- \* For electric heat applications, minimum airflow is set to 320 cfm/ton, unless specified otherwise, values found in electric heat temperature rise table.
- \* Dehumidification (hot gas reheat) or TXV with frostat and crankcase heaters are required on applications below 320 cfm/ton

<sup>(a)</sup> BAYLSDR006AB

<sup>(b)</sup> Field supplied fan sheave AK41x3/4" required. Field supplied belt may be necessary.



## Evaporator Fan Performance — High Efficiency

**Table 106. Belt drive evaporator fan performance – 5 tons high efficiency – THC060E3,E4,EW,F3,F4,FW horizontal airflow**

CFM	External Static Pressure (Inches of Water Gauge)																				
	0.10"		0.20"		0.30"		0.40"		0.50"		0.60"		0.70"		0.80"		0.90"		1.00"		
	RPM	BHP	RPM	BHP	RPM	BHP	RPM	BHP	RPM	BHP	RPM	BHP	RPM	BHP	RPM	BHP	RPM	BHP	RPM	BHP	
<b>1-hp Standard Motor &amp; Low Static Drive Accessory Kit<sup>(a)</sup></b>															<b>1-hp Standard Motor &amp; Drive</b>						
1000*	412	0.07	517	0.10	601	0.15	664	0.19	716	0.23	764	0.27	810	0.31	853	0.35	897	0.40	939	0.44	
1200*	456	0.1	542	0.14	631	0.19	702	0.24	758	0.29	808	0.33	851	0.38	892	0.43	932	0.48	970	0.53	
1400*	502	0.14	580	0.18	654	0.23	730	0.29	795	0.35	848	0.41	893	0.46	936	0.52	974	0.58	1010	0.63	
1600	550	0.19	622	0.24	688	0.29	753	0.35	820	0.41	881	0.49	930	0.55	975	0.62	1015	0.68	1052	0.75	
1800	598	0.25	668	0.31	728	0.37	785	0.42	843	0.49	903	0.56	960	0.64	1010	0.72	1053	0.80	1092	0.87	
2000	648	0.33	714	0.39	771	0.46	824	0.52	875	0.58	927	0.66	982	0.74	1034	0.83	1082	0.91	1126	1.00	
2200	699	0.42	762	0.50	816	0.57	866	0.63	914	0.70	960	0.77	1006	0.85	1056	0.94	1106	1.03	1152	1.13	
2400	750	0.54	810	0.61	863	0.69	911	0.77	956	0.84	999	0.92	1042	1.00	1084	1.08	1130	1.17	1176	1.27	
<b>External Static Pressure (Inches of Water Gauge)</b>																					
	1.10"		1.20"		1.30"		1.40"		1.50"												
CFM	RPM	BHP	RPM	BHP	RPM	BHP	RPM	BHP	RPM	BHP											
<b>1-hp Standard Motor &amp; Drive</b>																					
1000*	977	0.49	1014	0.53	1049	0.58	1084	0.63	1118	0.68											
1200*	1006	0.58	1042	0.63	1078	0.69	1112	0.74	1145	0.80											
1400*	1045	0.69	1078	0.74	1111	0.8	1144	0.86	1174	0.92											
1600	1087	0.81	1121	0.88	1152	0.94	1182	1.00	1213	1.07											
1800	1129	0.95	1163	1.02	1195	1.09	1226	1.16	1255	1.23											
2000	1165	1.08	1201	1.17	1236	1.25	1268	1.33	1298	1.41											
2200	1196	1.23	1237	1.33	1271	1.42	1305	1.51	1338	1.60											
2400	1219	1.37	1261	1.48	1301	1.58	1339	1.69	1373	1.79											
<b>1-hp Std. Motor &amp; Field Supplied High Static Drive<sup>(b)</sup></b>																					

**Notes:**

1. For standard evaporator fan speed (rpm), reference the standard motor and sheave/fan speed applicable table in the fan performance section.
2. Data includes pressure drop due to standard filters and wet coils. No accessories or options are included in pressure drop data.
3. To determine static pressure drop due to other options/accessories, refer to the applicable table in the fan performance section.
4. 1-hp fan motor heat (MBh) = 2.7672 x fan bhp + 0.4705.
5. Factory supplied motors, in commercial equipment, are definite purpose motors, specifically designed and tested to operate reliably and continuously at all cataloged conditions. Using the full horsepower range of our fan motors as shown in our tabular data will not result in nuisance tripping or premature motor failure. Our product's warranty will not be affected.
6. \* For 1000, 1200, and 1400 cfm, unit application below 320 cfm/ton are only applicable on T\_C models only (no gas heat). See below for restrictions.
7. \* For electric heat applications, minimum airflow is set to 320 cfm/ton, unless specified otherwise, values found in electric heat temperature rise table.
8. \* Dehumidification (hot gas reheat) or TXV with frostat and crankcase heaters are required on applications below 320 cfm/ton

<sup>(a)</sup> BAYLSDR006AB

<sup>(b)</sup> Field supplied fan sheave AK41x3/4" required. Field supplied belt may be necessary.



## Evaporator Fan Performance – High Efficiency

**Table 107. Belt drive evaporator fan performance – 5 tons high efficiency – YHC060E3,E4,F3,EW,F4,FW\*L,M low & medium gas heat downflow airflow**

External Static Pressure (Inches of Water Gauge)																						
		0.10"		0.20"		0.30"		0.40"		0.50"		0.60"		0.70"		0.80"		0.90"		1.00"		
CFM	RPM	BHP	RPM	BHP	RPM	BHP	RPM	BHP	RPM	BHP	RPM	BHP	RPM	BHP	RPM	BHP	RPM	BHP	RPM	BHP		
<b>1-hp Standard Motor &amp; Field Supplied Low Static Drive<sup>(a)</sup></b>											<b>1-hp Standard Motor &amp; Drive</b>											
1600	—	—	583	0.22	648	0.27	705	0.32	755	0.37	804	0.42	852	0.47	897	0.53	941	0.59	982	0.65		
1800	—	—	623	0.28	683	0.34	740	0.40	790	0.45	835	0.50	879	0.56	922	0.62	964	0.68	1004	0.74		
2000	605	0.30	665	0.36	721	0.42	774	0.48	824	0.55	870	0.61	911	0.66	951	0.73	991	0.79	1028	0.86		
2200	653	0.39	709	0.45	762	0.51	812	0.58	859	0.65	905	0.72	948	0.79	986	0.86	1022	0.92	1057	0.99		
2400	701	0.49	756	0.56	803	0.63	851	0.70	896	0.77	939	0.85	982	0.93	1022	1.00	1057	1.07	1092	1.14		
External Static Pressure (Inches of Water Gauge)																						
		1.10"		1.20"		1.30"		1.40"		1.50"												
CFM	RPM	BHP	RPM	BHP	RPM	BHP	RPM	BHP	RPM	BHP	RPM	BHP										
<b>1-hp Standard Motor &amp; Drive</b>																						
1600	1024	0.71	1061	0.77	1099	0.83	1136	0.90	1170	0.96												
1800	1044	0.81	1081	0.87	1118	0.94	1155	1.01	1188	1.08												
2000	1067	0.93	1103	1.00	1139	1.07	1175	1.14	1209	1.22												
2200	1094	1.06	1129	1.13	1163	1.21	1197	1.29	1229	1.36												
2400	1124	1.21	1157	1.29	1189	1.37	1222	1.45	—	—												
<b>1-hp Std. Motor &amp; Field Supplied High Static Drive<sup>(b)</sup></b>																						

**Notes:**

1. For standard evaporator fan speed (rpm), reference the standard motor and sheave/fan speed applicable table in the fan performance section.
2. Data includes pressure drop due to standard filters and wet coils. No accessories or options are included in pressure drop data.
3. To determine static pressure drop due to other options/accessories, refer to the applicable table in the fan performance section.
4. 1-hp fan motor heat (MBh) = 2.7672 x fan bhp + 0.4705.
5. Factory supplied motors, in commercial equipment, are definite purpose motors, specifically designed and tested to operate reliably and continuously at all cataloged conditions. Using the full horsepower range of our fan motors as shown in our tabular data will not result in nuisance tripping or premature motor failure. Our product's warranty will not be affected.

<sup>(a)</sup> Field supplied fan sheave AK69x3/4" required. Field supplied belt may be necessary.

<sup>(b)</sup> Field supplied fan sheave AK41x3/4" required. Field supplied belt may be necessary.

## Evaporator Fan Performance – High Efficiency

**Table 108. Belt drive evaporator fan performance – 5 tons high efficiency – YHC060E3,E4,F3,EW,F4,FW\*L,M low & medium gas heat horizontal airflow**

External Static Pressure (Inches of Water Gauge)																					
		0.10"		0.20"		0.30"		0.40"		0.50"		0.60"		0.70"		0.80"		0.90"		1.00"	
CFM	RPM	BHP	RPM	BHP	RPM	BHP	RPM	BHP	RPM	BHP	RPM	BHP	RPM	BHP	RPM	BHP	RPM	BHP	RPM	BHP	
<b>1-hp Standard Motor &amp; Field Supplied Low Static Drive<sup>(a)</sup></b>											<b>1-hp Standard Motor &amp; Drive</b>										
1600	566	0.21	633	0.26	694	0.31	747	0.36	798	0.41	848	0.47	895	0.52	939	0.58	981	0.65	1021	0.71	
1800	621	0.28	681	0.33	739	0.39	790	0.45	837	0.51	884	0.57	929	0.63	971	0.69	1013	0.76	1052	0.82	
2000	676	0.37	731	0.43	785	0.49	836	0.56	880	0.62	923	0.69	966	0.75	1006	0.82	1046	0.89	1084	0.96	
2200	732	0.48	784	0.54	832	0.61	881	0.68	927	0.75	967	0.83	1005	0.90	1044	0.97	1082	1.04	1118	1.12	
2400	789	0.61	838	0.68	882	0.75	927	0.82	972	0.90	1012	0.98	1049	1.06	1085	1.14	1121	1.22	1155	1.30	
External Static Pressure (Inches of Water Gauge)																					
		1.10"		1.20"		1.30"		1.40"		1.50"											
CFM	RPM	BHP	RPM	BHP	RPM	BHP	RPM	BHP	RPM	BHP											
<b>1-hp Standard Motor &amp; Drive</b>																					
1600	1060	0.78	1097	0.84	1135	0.91	1169	0.98	1203	1.04											
1800	1090	0.89	1126	0.96	1161	1.04	1195	1.11	1229	1.19											
2000	1121	1.03	1156	1.10	1192	1.18	1224	1.26	1257	1.34											
2200	1155	1.19	1189	1.27	1223	1.34	1256	1.42	—	—											
2400	1190	1.38	1223	1.46	—	—	—	—	—	—											
<b>1-hp Std. Motor &amp; Field Supplied High Static Drive<sup>(b)</sup></b>																					

**Notes:**

1. For standard evaporator fan speed (rpm), reference the standard motor and sheave/fan speed applicable table in the fan performance section.
2. Data includes pressure drop due to standard filters and wet coils. No accessories or options are included in pressure drop data.
3. Data does not include pressure drop due to reheat coil.
4. To determine static pressure drop due to other options/accessories, refer to the applicable table in the fan performance section.
5. 1-hp fan motor heat (MBh) = 2.7672 x fan bhp + 0.4705.
6. Factory supplied motors, in commercial equipment, are definite purpose motors, specifically designed and tested to operate reliably and continuously at all cataloged conditions. Using the full horsepower range of our fan motors as shown in our tabular data will not result in nuisance tripping or premature motor failure. Our product's warranty will not be affected.

<sup>(a)</sup> Field supplied fan sheave AK69x3/4" required. Field supplied belt may be necessary.

<sup>(b)</sup> Field supplied fan sheave AK41x3/4" required. Field supplied belt may be necessary.



## Evaporator Fan Performance – High Efficiency

**Table 109. Belt drive evaporator fan performance – 5 tons high efficiency – YHC060E3,E4,EW,F3,F4,FW\*H high gas heat downflow airflow**

External Static Pressure (Inches of Water Gauge)																					
		0.10"		0.20"		0.30"		0.40"		0.50"		0.60"		0.70"		0.80"		0.90"		1.00"	
CFM	RPM	BHP	RPM	BHP	RPM	BHP	RPM	BHP	RPM	BHP	RPM	BHP	RPM	BHP	RPM	BHP	RPM	BHP	RPM	BHP	
1-hp Standard Motor & Field Supplied Low Static Drive <sup>(a)</sup>											1-hp Standard Motor & Drive										
1600	—	—	595	0.22	658	0.27	716	0.32	768	0.37	817	0.42	864	0.47	910	0.53	954	0.59	996	0.65	
1800	—	—	637	0.29	697	0.34	752	0.40	802	0.45	849	0.51	893	0.56	936	0.62	979	0.68	1019	0.75	
2000	621	0.31	680	0.36	737	0.42	790	0.49	838	0.55	884	0.61	927	0.67	967	0.73	1007	0.80	1046	0.86	
2200	671	0.40	726	0.46	779	0.52	829	0.59	876	0.66	919	0.72	962	0.79	1002	0.86	1039	0.93	1076	1.00	
2400	721	0.50	773	0.57	822	0.64	870	0.71	916	0.78	957	0.86	998	0.93	1036	1.00	1074	1.08	1109	1.15	
External Static Pressure (Inches of Water Gauge)																					
		1.10"		1.20"		1.30"		1.40"		1.50"											
CFM	RPM	BHP	RPM	BHP	RPM	BHP	RPM	BHP	RPM	BHP											
1-hp Standard Motor & Drive																					
1600	1037	0.72	1076	0.78	1114	0.85	1151	0.91	1184	0.98											
1800	1058	0.82	1096	0.88	1133	0.95	1169	1.02	1204	1.10											
2000	1083	0.93	1120	1.00	1155	1.07	1189	1.15	1224	1.23											
2200	1111	1.07	1146	1.14	1181	1.22	1214	1.29	1248	1.37											
2400	1144	1.23	1177	1.30	1210	1.38	1241	1.46	1274	1.54											
1-hp Std. Motor & Field Supplied High Static Drive <sup>(b)</sup>																					

**Notes:**

- For standard evaporator fan speed (rpm), reference the standard motor and sheave/fan speed applicable table in the fan performance section.
- Data includes pressure drop due to standard filters and wet coils. No accessories or options are included in pressure drop data.
- Data does not include pressure drop due to reheat coil.
- To determine static pressure drop due to other options/accessories, refer to the applicable table in the fan performance section.
- 1-hp fan motor heat (MBh) = 2.7672 x fan bhp + 0.4705.
- Factory supplied motors, in commercial equipment, are definite purpose motors, specifically designed and tested to operate reliably and continuously at all cataloged conditions. Using the full horsepower range of our fan motors as shown in our tabular data will not result in nuisance tripping or premature motor failure. Our product's warranty will not be affected.

<sup>(a)</sup> Field supplied fan sheave AK69x3/4" required. Field supplied belt may be necessary.

<sup>(b)</sup> Field supplied fan sheave AK41x3/4" required. Field supplied belt may be necessary.

## Evaporator Fan Performance – High Efficiency

**Table 110. Belt drive evaporator fan performance – 5 tons high efficiency – YHC060E3,E4,EW,F3,F4,FW\*H high gas heat horizontal airflow**

External Static Pressure (Inches of Water Gauge)																					
		0.10"		0.20"		0.30"		0.40"		0.50"		0.60"		0.70"		0.80"		0.90"		1.00"	
CFM	RPM	BHP	RPM	BHP	RPM	BHP	RPM	BHP	RPM	BHP	RPM	BHP	RPM	BHP	RPM	BHP	RPM	BHP	RPM	BHP	
<b>1-hp Standard Motor &amp; Field Supplied Low Static Drive<sup>(a)</sup></b>											<b>1-hp Standard Motor &amp; Drive</b>										
1600	570	0.21	639	0.26	703	0.32	760	0.37	809	0.41	854	0.46	894	0.52	936	0.58	977	0.64	1019	0.70	
1800	620	0.28	689	0.34	746	0.40	801	0.46	851	0.52	896	0.57	937	0.62	974	0.68	1011	0.75	1048	0.81	
2000	671	0.36	741	0.44	792	0.50	844	0.57	893	0.64	939	0.71	980	0.76	1019	0.82	1054	0.88	1087	0.95	
2200	723	0.46	791	0.55	843	0.62	889	0.69	936	0.77	981	0.85	1022	0.92	1061	0.99	1097	1.05	1131	1.11	
2400	776	0.58	841	0.68	895	0.76	937	0.84	981	0.91	1023	1.00	1064	1.09	1103	1.17	1140	1.25	1173	1.31	
External Static Pressure (Inches of Water Gauge)																					
		1.10"		1.20"		1.30"		1.40"		1.50"											
CFM	RPM	BHP	RPM	BHP	RPM	BHP	RPM	BHP	RPM	BHP											
<b>1-hp Standard Motor &amp; Drive</b>																					
1600	1057	0.76	1096	0.83	1133	0.90	1167	0.96	1201	1.03											
1800	1086	0.88	1123	0.95	1159	1.02	1192	1.09	1226	1.17											
2000	1119	1.02	1153	1.09	1188	1.17	1221	1.24	1253	1.32											
2200	1162	1.18	1193	1.25	1223	1.33	1253	1.41	1284	1.49											
2400	1206	1.38	1236	1.44	1266	1.52	1294	1.61	1320	1.69											
<b>1-hp Std. Motor &amp; Field Supplied High Static Drive<sup>(b)</sup></b>																					

**Notes:**

1. For standard evaporator fan speed (rpm), reference the standard motor and sheave/fan speed applicable table in the fan performance section.
2. Data includes pressure drop due to standard filters and wet coils. No accessories or options are included in pressure drop data.
3. Data does not include pressure drop due to reheat coil.
4. To determine static pressure drop due to other options/accessories, refer to the applicable table in the fan performance section.
5. 1-hp fan motor heat (MBh) = 2.7672 x fan bhp + 0.4705.
6. Factory supplied motors, in commercial equipment, are definite purpose motors, specifically designed and tested to operate reliably and continuously at all cataloged conditions. Using the full horsepower range of our fan motors as shown in our tabular data will not result in nuisance tripping or premature motor failure. Our product's warranty will not be affected.

<sup>(a)</sup> Field supplied fan sheave AK69x3/4" required. Field supplied belt may be necessary.

<sup>(b)</sup> Field supplied fan sheave AK41x3/4" required. Field supplied belt may be necessary.



## Evaporator Fan Performance – High Efficiency

**Table 111. Belt drive evaporator fan performance – 6 tons high efficiency – THC072E3,E4,EW,F3,F4,FW downflow airflow**

External Static Pressure (Inches of Water Gauge)																					
		0.10"		0.20"		0.30"		0.40"		0.50"		0.60"		0.70"		0.80"		0.90"		1.00"	
CFM	RPM	BHP	RPM	BHP	RPM	BHP	RPM	BHP	RPM	BHP	RPM	BHP	RPM	BHP	RPM	BHP	RPM	BHP	RPM	BHP	
1-hp Standard Motor & Low Static Drive Accessory Kit <sup>(a)</sup>											1-hp Standard Motor & Drive										
1920	—	—	437	0.23	491	0.29	545	0.36	594	0.44	637	0.51	677	0.58	715	0.65	750	0.72	784	0.80	
2160	407	0.22	465	0.29	513	0.36	563	0.43	610	0.51	654	0.60	694	0.68	731	0.76	766	0.84	799	0.92	
2400	439	0.29	494	0.37	540	0.44	583	0.51	628	0.60	671	0.69	711	0.78	748	0.87	783	0.96	817	1.05	
2640	472	0.36	523	0.45	568	0.54	609	0.62	647	0.70	688	0.79	728	0.89	765	0.99	801	1.09	834	1.19	
2880	505	0.45	553	0.55	597	0.65	637	0.74	673	0.82	708	0.91	746	1.01	782	1.12	817	1.23	851	1.34	
External Static Pressure (Inches of Water Gauge)																					
		1.10"		1.20"		1.30"		1.40"		1.50"		1.60"		1.70"		1.80"		1.90"		2.00"	
CFM	RPM	BHP	RPM	BHP	RPM	BHP	RPM	BHP	RPM	BHP	RPM	BHP	RPM	BHP	RPM	BHP	RPM	BHP	RPM	BHP	
1-hp Standard Motor & Drive											2-hp Oversized Motor & Drive										
1920	815	0.87	847	0.94	875	1.01	903	1.08	930	1.16	958	1.23	984	1.31	1008	1.38	1033	1.46	1056	1.53	
2160	832	1.00	863	1.08	891	1.16	920	1.24	947	1.32	974	1.41	999	1.49	1024	1.57	1048	1.65	1071	1.73	
2400	848	1.14	878	1.23	908	1.32	935	1.41	963	1.50	989	1.59	1015	1.68	1040	1.77	1064	1.86	1088	1.95	
2640	865	1.29	895	1.39	924	1.48	953	1.59	979	1.68	1006	1.78	1031	1.88	1056	1.98	1080	2.08	1104	2.18	
2880	882	1.45	912	1.56	941	1.66	969	1.77	996	1.88	1021	1.98	1047	2.09	1072	2.20	—	—	—	—	

**Notes:**

1. For standard evaporator fan speed (rpm), reference the standard motor and sheave/fan speed applicable table in the fan performance section.
2. Data includes pressure drop due to standard filters and wet coils.
3. To determine static pressure drop due to other options/accessories, refer to the applicable table in the fan performance section.
4. 1-hp fan motor heat (MBH) = 2.829 x fan bhp + .4024. 2-hp fan motor heat (Mbh) = 3.000 x fan bhp + .5000.
5. Factory supplied motors, in commercial equipment, are definite purpose motors, specifically designed and tested to operate reliably and continuously at all cataloged conditions. Using the full horsepower range of our fan motors as shown in our tabular data will not result in nuisance tripping or premature motor failure. Our product's warranty will not be affected.

<sup>(a)</sup> BAYLSDR009AA

## Evaporator Fan Performance – High Efficiency

**Table 112. Belt drive evaporator fan performance – 6 tons high efficiency – THC072E3,E4,EW,F3,F4,FW horizontal airflow**

External Static Pressure (Inches of Water Gauge)																					
		0.10"		0.20"		0.30"		0.40"		0.50"		0.60"		0.70"		0.80"		0.90"		1.00"	
CFM	RPM	BHP	RPM	BHP	RPM	BHP	RPM	BHP	RPM	BHP	RPM	BHP	RPM	BHP	RPM	BHP	RPM	BHP	RPM	BHP	
<b>1-hp Standard Motor &amp; Low Static Drive Accessory Kit<sup>(a)</sup></b>											<b>1-hp Standard Motor &amp; Drive</b>										
1920	422	0.21	490	0.28	551	0.37	595	0.44	634	0.51	670	0.59	704	0.66	735	0.74	765	0.82	794	0.89	
2160	461	0.28	514	0.35	581	0.46	629	0.55	667	0.62	702	0.70	735	0.78	767	0.87	796	0.96	824	1.04	
2400	501	0.37	547	0.44	604	0.54	661	0.66	701	0.75	735	0.84	768	0.93	798	1.02	827	1.11	855	1.21	
2640	541	0.47	584	0.55	629	0.64	685	0.77	734	0.90	769	1.00	800	1.09	831	1.19	860	1.29	886	1.39	
2880	582	0.59	623	0.69	661	0.76	708	0.88	759	1.03	803	1.17	834	1.28	864	1.39	892	1.49	919	1.59	
<b>External Static Pressure (Inches of Water Gauge)</b>																					
		1.10"		1.20"		1.30"		1.40"		1.50"		1.60"		1.70"		1.80"		1.90"		2.00"	
CFM	RPM	BHP	RPM	BHP	RPM	BHP	RPM	BHP	RPM	BHP	RPM	BHP	RPM	BHP	RPM	BHP	RPM	BHP	RPM	BHP	
<b>1-hp Standard Motor &amp; Drive</b>											<b>2-hp Oversized Motor &amp; Drive</b>										
1920	821	0.98	847	1.06	873	1.14	896	1.22	920	1.30	943	1.39	965	1.47	986	1.55	1006	1.64	1028	1.73	
2160	851	1.13	876	1.22	902	1.31	925	1.39	949	1.49	971	1.58	993	1.67	1014	1.76	1035	1.85	1055	1.95	
2400	881	1.30	907	1.40	932	1.49	955	1.59	978	1.69	1001	1.79	1022	1.88	1043	1.98	1064	2.09	1084	2.19	
2640	913	1.49	938	1.59	962	1.70	986	1.80	1009	1.91	1030	2.02	1052	2.12	1074	2.23	—	—	—	—	
2880	944	1.70	969	1.81	993	1.92	1016	2.04	1040	2.15	1061	2.26	—	—	—	—	—	—	—	—	

**Notes:**

1. For standard evaporator fan speed (rpm), reference the standard motor and sheave/fan speed applicable table in the fan performance section.
2. Data includes pressure drop due to standard filters and wet coils.
3. To determine static pressure drop due to other options/accessories, refer to the applicable table in the fan performance section.
4. 1-hp fan motor heat (MBH) = 2.829 x fan bhp + .4024. 2-hp fan motor heat (Mbh) = 3.000 x fan bhp + .5000.
5. Factory supplied motors, in commercial equipment, are definite purpose motors, specifically designed and tested to operate reliably and continuously at all cataloged conditions. Using the full horsepower range of our fan motors as shown in our tabular data will not result in nuisance tripping or premature motor failure. Our product's warranty will not be affected.

<sup>(a)</sup> BAYLSDR009AA



## Evaporator Fan Performance – High Efficiency

**Table 113. Belt drive evaporator fan performance – 6 tons high efficiency – YHC072E3,E4,EW,F3,F4,FW low & medium gas heat downflow airflow**

External Static Pressure (Inches of Water Gauge)																					
		0.10"		0.20"		0.30"		0.40"		0.50"		0.60"		0.70"		0.80"		0.90"		1.00"	
CFM	RPM	BHP	RPM	BHP	RPM	BHP	RPM	BHP	RPM	BHP	RPM	BHP	RPM	BHP	RPM	BHP	RPM	BHP	RPM	BHP	
<b>1-hp Standard Motor &amp; Low Static Drive Accessory Kit<sup>(a)</sup></b>																					
1920	393	0.18	450	0.23	503	0.29	549	0.35	590	0.41	628	0.47	663	0.53	696	0.59	726	0.65	755	0.71	
2160	427	0.24	480	0.30	529	0.37	574	0.43	615	0.50	652	0.57	687	0.63	719	0.70	750	0.77	779	0.84	
2400	463	0.31	511	0.38	557	0.45	601	0.52	641	0.60	678	0.67	712	0.75	744	0.82	774	0.90	803	0.97	
2640	500	0.39	544	0.47	587	0.55	627	0.63	666	0.71	703	0.79	737	0.87	769	0.96	798	1.04	827	1.12	
2880	538	0.50	579	0.58	618	0.66	656	0.75	693	0.84	729	0.93	762	1.01	794	1.10	824	1.19	852	1.28	
<b>External Static Pressure (Inches of Water Gauge)</b>																					
		1.10"		1.20"		1.30"		1.40"		1.50"		1.60"		1.70"		1.80"		1.90"		2.00"	
CFM	RPM	BHP	RPM	BHP	RPM	BHP	RPM	BHP	RPM	BHP	RPM	BHP	RPM	BHP	RPM	BHP	RPM	BHP	RPM	BHP	
<b>1-hp Standard Motor &amp; Drive</b>																					
1920	783	0.77	811	0.84	836	0.90	861	0.96	885	1.02	908	1.08	930	1.14	953	1.20	973	1.26	995	1.33	
2160	806	0.90	833	0.97	859	1.04	883	1.11	907	1.18	931	1.25	952	1.31	974	1.38	996	1.45	1016	1.52	
2400	830	1.05	856	1.12	883	1.20	906	1.27	930	1.35	952	1.42	976	1.50	998	1.58	1018	1.65	1039	1.73	
2640	854	1.20	880	1.29	906	1.37	930	1.45	953	1.53	976	1.62	998	1.70	1020	1.78	1041	1.86	1062	1.95	
2880	879	1.37	905	1.47	929	1.55	953	1.64	977	1.73	1000	1.83	1022	1.91	1044	2.01	1063	2.09	1084	2.18	
<b>2-hp Oversized Motor &amp; Drive</b>																					

**Notes:**

1. For standard evaporator fan speed (rpm), reference the standard motor and sheave/fan speed applicable table in the fan performance section.
2. Data includes pressure drop due to standard filters and wet coils.
3. To determine static pressure drop due to other options/accessories, refer to the applicable table in the fan performance section.
4. 1-hp fan motor heat (MBH) = 2.829 x fan bhp + .4024. 2-hp fan motor heat (Mbh) = 3.000 x fan bhp + .5000.
5. Factory supplied motors, in commercial equipment, are definite purpose motors, specifically designed and tested to operate reliably and continuously at all cataloged conditions. Using the full horsepower range of our fan motors as shown in our tabular data will not result in nuisance tripping or premature motor failure. Our product's warranty will not be affected.

<sup>(a)</sup> BAYLSDR009AA



## Evaporator Fan Performance – High Efficiency

**Table 114. Belt drive evaporator fan performance – 6 tons high efficiency – YHC072E3,E4,EW,F3,F4,FW low & medium gas heat horizontal airflow**

External Static Pressure (Inches of Water Gauge)																					
		0.10"		0.20"		0.30"		0.40"		0.50"		0.60"		0.70"		0.80"		0.90"		1.00"	
CFM	RPM	BHP	RPM	BHP	RPM	BHP	RPM	BHP	RPM	BHP	RPM	BHP	RPM	BHP	RPM	BHP	RPM	BHP	RPM	BHP	
<b>1-hp Standard Motor &amp; Low Static Drive Accessory Kit<sup>(a)</sup></b>														<b>1-hp Standard Motor &amp; Drive</b>							
1920	462	0.25	517	0.32	565	0.38	609	0.45	648	0.52	684	0.59	719	0.66	751	0.73	782	0.80	811	0.87	
2160	503	0.33	557	0.41	602	0.49	644	0.56	682	0.64	718	0.71	751	0.79	783	0.87	813	0.95	842	1.03	
2400	546	0.43	598	0.53	641	0.61	680	0.69	717	0.78	753	0.86	785	0.95	815	1.03	845	1.12	873	1.21	
2640	590	0.56	640	0.66	681	0.76	719	0.85	754	0.94	788	1.03	820	1.12	850	1.21	879	1.31	906	1.41	
2880	636	0.71	681	0.82	722	0.93	758	1.02	793	1.13	824	1.22	855	1.32	885	1.42	913	1.52	940	1.62	
External Static Pressure (Inches of Water Gauge)																					
		1.10"		1.20"		1.30"		1.40"		1.50"		1.60"		1.70"		1.80"		1.90"		2.00"	
CFM	RPM	BHP	RPM	BHP	RPM	BHP	RPM	BHP	RPM	BHP	RPM	BHP	RPM	BHP	RPM	BHP	RPM	BHP	RPM	BHP	
<b>1-hp Standard Motor &amp; Drive</b>														<b>2-hp Oversized Motor &amp; Drive</b>							
1920	838	0.94	865	1.01	890	1.08	915	1.16	939	1.23	962	1.30	985	1.37	1007	1.45	1027	1.52	1049	1.59	
2160	870	1.11	895	1.19	920	1.27	945	1.35	969	1.43	991	1.51	1014	1.59	1035	1.67	1057	1.75	1077	1.83	
2400	901	1.30	926	1.38	952	1.47	975	1.56	999	1.65	1022	1.74	1044	1.82	1066	1.91	1086	2.00	1108	2.09	
2640	933	1.51	959	1.60	982	1.69	1007	1.79	1029	1.89	1053	1.99	1075	2.08	1096	2.18	1116	2.27	—	—	
2880	966	1.73	991	1.84	1015	1.94	1039	2.05	1062	2.16	1084	2.26	—	—	—	—	—	—	—	—	

**Notes:**

1. For standard evaporator fan speed (rpm), reference the standard motor and sheave/fan speed applicable table in the fan performance section.
2. Data includes pressure drop due to standard filters and wet coils.
3. To determine static pressure drop due to other options/accessories, refer to the applicable table in the fan performance section.
4. 1-hp fan motor heat (MBH) = 2.829 x fan bhp + .4024. 2-hp fan motor heat (Mbh) = 3.000 x fan bhp + .5000.
5. Factory supplied motors, in commercial equipment, are definite purpose motors, specifically designed and tested to operate reliably and continuously at all cataloged conditions. Using the full horsepower range of our fan motors as shown in our tabular data will not result in nuisance tripping or premature motor failure. Our product's warranty will not be affected.

<sup>(a)</sup> BAYLSDR009AA



## Evaporator Fan Performance – High Efficiency

**Table 115. Belt drive evaporator fan performance – 6 tons high efficiency – YHC072E3,E4,EW,F3,F4,FW high gas heat, downflow airflow**

External Static Pressure (Inches of Water Gauge)																					
		0.10"		0.20"		0.30"		0.40"		0.50"		0.60"		0.70"		0.80"		0.90"		1.00"	
CFM	RPM	BHP	RPM	BHP	RPM	BHP	RPM	BHP	RPM	BHP	RPM	BHP	RPM	BHP	RPM	BHP	RPM	BHP	RPM	BHP	
<b>1-hp Standard Motor &amp; Low Static Drive Accessory Kit<sup>(a)</sup></b>											<b>1-hp Standard Motor &amp; Drive</b>										
1920	412	0.20	472	0.26	524	0.32	571	0.38	612	0.44	651	0.51	686	0.57	719	0.64	750	0.71	779	0.77	
2160	454	0.27	504	0.33	553	0.40	599	0.47	640	0.54	678	0.61	712	0.68	745	0.75	776	0.83	805	0.90	
2400	495	0.36	534	0.41	585	0.50	627	0.57	668	0.65	705	0.73	739	0.81	771	0.88	802	0.96	831	1.05	
2640	535	0.46	570	0.52	617	0.61	657	0.69	696	0.77	732	0.86	767	0.95	799	1.03	829	1.12	858	1.20	
2880	575	0.58	612	0.65	646	0.72	690	0.83	725	0.92	761	1.01	795	1.11	827	1.20	857	1.29	884	1.38	
<b>External Static Pressure (Inches of Water Gauge)</b>																					
		1.10"		1.20"		1.30"		1.40"		1.50"		1.60"		1.70"		1.80"		1.90"		2.00"	
CFM	RPM	BHP	RPM	BHP	RPM	BHP	RPM	BHP	RPM	BHP	RPM	BHP	RPM	BHP	RPM	BHP	RPM	BHP	RPM	BHP	
<b>1-hp Standard Motor &amp; Drive</b>											<b>2-hp Oversized Motor &amp; Drive</b>										
1920	808	0.84	835	0.91	862	0.97	887	1.04	910	1.11	935	1.18	957	1.25	979	1.32	1001	1.39	1022	1.46	
2160	834	0.98	860	1.05	886	1.13	911	1.20	935	1.28	959	1.35	982	1.43	1004	1.51	1025	1.58	1046	1.66	
2400	859	1.13	886	1.21	912	1.29	936	1.37	960	1.45	984	1.54	1007	1.63	1028	1.71	1050	1.79	1071	1.88	
2640	885	1.29	911	1.38	937	1.47	962	1.56	985	1.65	1009	1.74	1032	1.84	1054	1.93	1074	2.01	1095	2.11	
2880	913	1.48	938	1.57	963	1.67	988	1.77	1012	1.86	1035	1.96	1057	2.06	1079	2.16	1099	2.26	—	—	

**Notes:**

1. For standard evaporator fan speed (rpm), reference the standard motor and sheave/fan speed applicable table in the fan performance section.
2. Data includes pressure drop due to standard filters and wet coils.
3. To determine static pressure drop due to other options/accessories, refer to the applicable table in the fan performance section.
4. 1-hp fan motor heat (MBH) = 2.829 x fan bhp + .4024. 2-hp fan motor heat (Mbh) = 3.000 x fan bhp + .5000.
5. Factory supplied motors, in commercial equipment, are definite purpose motors, specifically designed and tested to operate reliably and continuously at all cataloged conditions. Using the full horsepower range of our fan motors as shown in our tabular data will not result in nuisance tripping or premature motor failure. Our product's warranty will not be affected.

<sup>(a)</sup> BAYLSDR009AA

## Evaporator Fan Performance — High Efficiency

**Table 116. Belt drive evaporator fan performance – 6 tons high efficiency – YHC072E3,E4,EW,F3,F4,FW high gas heat, horizontal airflow**

External Static Pressure (Inches of Water Gauge)																					
		0.10"		0.20"		0.30"		0.40"		0.50"		0.60"		0.70"		0.80"		0.90"		1.00"	
CFM	RPM	BHP	RPM	BHP	RPM	BHP	RPM	BHP	RPM	BHP	RPM	BHP	RPM	BHP	RPM	BHP	RPM	BHP	RPM	BHP	
1-hp Standard Motor & Low Static Drive Accessory Kit <sup>(a)</sup>											1-hp Standard Motor & Drive										
1920	476	0.27	528	0.34	575	0.40	619	0.47	660	0.54	697	0.62	731	0.69	763	0.77	793	0.84	821	0.92	
2160	520	0.36	571	0.44	614	0.51	655	0.59	694	0.67	731	0.75	765	0.83	796	0.91	826	1.00	854	1.08	
2400	566	0.47	615	0.56	656	0.65	694	0.73	730	0.81	765	0.90	799	0.99	830	1.08	860	1.17	888	1.27	
2640	612	0.61	659	0.71	698	0.81	734	0.89	769	0.98	802	1.08	834	1.17	865	1.27	894	1.37	922	1.47	
2880	660	0.77	703	0.88	742	0.99	777	1.09	808	1.18	840	1.28	870	1.38	899	1.49	929	1.60	957	1.70	
External Static Pressure (Inches of Water Gauge)																					
		1.10"		1.20"		1.30"		1.40"		1.50"		1.60"		1.70"		1.80"		1.90"		2.00"	
CFM	RPM	BHP	RPM	BHP	RPM	BHP	RPM	BHP	RPM	BHP	RPM	BHP	RPM	BHP	RPM	BHP	RPM	BHP	RPM	BHP	
1-hp Standard Motor & Drive											2-hp Oversized Motor & Drive										
1920	849	0.99	876	1.07	900	1.14	925	1.22	949	1.30	972	1.38	994	1.45	1015	1.53	1037	1.61	1057	1.69	
2160	881	1.17	908	1.25	933	1.34	957	1.42	980	1.51	1003	1.59	1026	1.68	1046	1.76	1067	1.85	1088	1.94	
2400	915	1.36	941	1.46	966	1.55	990	1.64	1012	1.73	1035	1.83	1057	1.92	1079	2.02	1099	2.11	1119	2.21	
2640	949	1.57	975	1.67	999	1.78	1023	1.88	1045	1.98	1068	2.09	1090	2.19	1110	2.29	—	—	—	—	
2880	983	1.81	1009	1.92	1034	2.03	1056	2.14	1080	2.26	—	—	—	—	—	—	—	—	—	—	

**Notes:**

1. For standard evaporator fan speed (rpm), reference the standard motor and sheave/fan speed applicable table in the fan performance section.
2. Data includes pressure drop due to standard filters and wet coils.
3. To determine static pressure drop due to other options/accessories, refer to the applicable table in the fan performance section.
4. 1-hp fan motor heat (MBH) = 2.829 x fan bhp + .4024. 2-hp fan motor heat (Mbh) = 3.000 x fan bhp + .5000.
5. Factory supplied motors, in commercial equipment, are definite purpose motors, specifically designed and tested to operate reliably and continuously at all cataloged conditions. Using the full horsepower range of our fan motors as shown in our tabular data will not result in nuisance tripping or premature motor failure. Our product's warranty will not be affected.

<sup>(a)</sup> BAYLSDR009AA



## Evaporator Fan Performance – High Efficiency

**Table 117. Direct drive evaporator fan performance – 6 tons high efficiency – THC074F3,F4 downflow airflow**

External Static Pressure (Inches of Water Gauge)																				
	0.10"		0.20"		0.30"		0.40"		0.50"		0.60"		0.70"		0.80"		0.90"		1.00"	
CFM	RPM	BHP	RPM	BHP	RPM	BHP	RPM	BHP	RPM	BHP	RPM	BHP	RPM	BHP	RPM	BHP	RPM	BHP	RPM	BHP
1200*	422	0.04	486	0.07	539	0.1	585	0.13	627	0.16	665	0.2	701	0.24	734	0.28	765	0.32	794	0.36
1440*	479	0.06	538	0.09	589	0.12	634	0.16	674	0.19	711	0.23	745	0.27	778	0.32	809	0.36	838	0.41
1680*	538	0.08	593	0.11	641	0.15	684	0.19	723	0.23	759	0.27	793	0.32	824	0.36	854	0.41	883	0.46
1920	598	0.10	649	0.14	695	0.18	736	0.23	773	0.27	808	0.32	841	0.37	872	0.41	901	0.46	930	0.52
2160	660	0.14	707	0.18	750	0.23	789	0.27	825	0.32	859	0.37	891	0.42	921	0.47	950	0.53	977	0.58
2400	722	0.18	767	0.23	807	0.27	844	0.32	879	0.38	912	0.43	943	0.48	972	0.54	1000	0.60	1027	0.66
2640	785	0.23	827	0.28	865	0.33	900	0.38	934	0.44	965	0.50	995	0.56	1024	0.62	1051	0.68	1077	0.74
2880	848	0.28	888	0.34	924	0.40	958	0.45	990	0.51	1020	0.58	1049	0.64	1077	0.70	1103	0.77	1129	0.83
External Static Pressure (Inches of Water Gauge)																				
	1.10"		1.20"		1.30"		1.40"		1.50"		1.60"		1.70"		1.80"		1.90"		2.00"	
CFM	RPM	BHP	RPM	BHP	RPM	BHP	RPM	BHP	RPM	BHP	RPM	BHP	RPM	BHP	RPM	BHP	RPM	BHP	RPM	BHP
1200*	823	0.40	850	0.45	877	0.5	903	0.55	927	0.59	950	0.64	974	0.7	995	0.75	1017	0.8	1039	0.86
1440*	866	0.45	894	0.5	919	0.55	945	0.6	969	0.66	992	0.71	1014	0.76	1037	0.82	1058	0.87	1079	0.93
1680*	911	0.51	937	0.56	963	0.61	987	0.67	1012	0.72	1035	0.78	1057	0.84	1079	0.89	1100	0.95	1121	1.01
1920	957	0.57	983	0.63	1009	0.68	1032	0.74	1056	0.80	1079	0.85	1101	0.92	1122	0.98	1143	1.04	1164	1.10
2160	1004	0.64	1029	0.70	1055	0.76	1078	0.82	1101	0.88	1124	0.94	1146	1.00	1167	1.07	1188	1.13	1209	1.20
2400	1053	0.72	1077	0.78	1102	0.84	1125	0.90	1148	0.97	1171	1.04	1192	1.10	1213	1.17	1234	1.24	1254	1.31
2640	1103	0.80	1127	0.87	1151	0.93	1174	1.00	1196	1.07	1218	1.14	1239	1.21	1260	1.28	1280	1.35	1300	1.42
2880	1154	0.90	1177	0.97	1201	1.04	1223	1.11	1245	1.18	1267	1.25	1287	1.32	1308	1.40	1328	1.47	1348	1.55

**Notes:**

1. For direct drive evaporator fan speed (rpm), refer to the applicable table in the fan performance section.
2. Data includes pressure drop due to standard filters and wet coils.
3. To determine static pressure drop due to other options/accessories, refer to the applicable table in the fan performance section.
4. Direct drive fan motor heat (MBh) = 2.7912 x fan bhp + 0.1388
5. Factory supplied motors, in commercial equipment, are definite purpose motors, specifically designed and tested to operate reliably and continuously at all cataloged conditions. Using the full horsepower range of our fan motors as shown in our tabular data will not result in nuisance tripping or premature motor failure. Our product's warranty will not be affected.
6. \* For 1200, 1440, and 1680 cfm, unit application below 320 cfm/ton are only applicable on T\_C models only (no gas heat). See below for restrictions.
7. \* For electric heat applications, minimum airflow is set to 320 cfm/ton, unless specified otherwise, values found in electric heat temperature rise table.
8. \* TXV with Froststat™ and crankcase heaters are required on applications below 320 cfm/ton.

## Evaporator Fan Performance – High Efficiency

**Table 118. Direct drive evaporator fan performance – 6 tons high efficiency – THC074F3,F4 horizontal airflow**

External Static Pressure (Inches of Water Gauge)																				
	0.10"		0.20"		0.30"		0.40"		0.50"		0.60"		0.70"		0.80"		0.90"		1.00"	
CFM	RPM	BHP	RPM	BHP	RPM	BHP	RPM	BHP	RPM	BHP	RPM	BHP	RPM	BHP	RPM	BHP	RPM	BHP	RPM	BHP
1200*	416	0.03	483	0.04	538	0.06	586	0.08	629	0.10	669	0.12	706	0.15	740	0.17	773	0.2	804	0.22
1440*	470	0.04	533	0.06	586	0.08	632	0.10	674	0.12	713	0.15	748	0.17	782	0.20	814	0.23	844	0.25
1680*	526	0.05	584	0.08	635	0.1	680	0.12	720	0.15	758	0.18	793	0.20	826	0.23	858	0.26	887	0.29
1920	583	0.07	638	0.10	686	0.12	729	0.15	768	0.18	805	0.21	839	0.24	871	0.27	902	0.30	931	0.33
2160	642	0.09	693	0.12	739	0.15	780	0.18	818	0.21	853	0.24	887	0.28	918	0.31	948	0.34	977	0.38
2400	702	0.11	750	0.15	793	0.19	832	0.22	869	0.25	903	0.29	935	0.32	966	0.35	996	0.39	1023	0.43
2640	762	0.14	807	0.19	848	0.23	886	0.26	921	0.30	954	0.33	986	0.37	1015	0.41	1043	0.45	1071	0.48
2880	823	0.17	865	0.22	904	0.27	940	0.31	974	0.35	1006	0.39	1037	0.43	1066	0.47	1094	0.51	1121	0.55
External Static Pressure (Inches of Water Gauge)																				
	1.10"		1.20"		1.30"		1.40"		1.50"		1.60"		1.70"		1.80"		1.90"		2.00"	
CFM	RPM	BHP	RPM	BHP	RPM	BHP	RPM	BHP	RPM	BHP	RPM	BHP	RPM	BHP	RPM	BHP	RPM	BHP	RPM	BHP
1200*	833	0.25	861	0.28	888	0.3	913	0.33	939	0.36	964	0.39	987	0.42	1009	0.45	1033	0.48	1054	0.52
1440*	873	0.28	901	0.31	928	0.34	954	0.37	979	0.4	1003	0.43	1027	0.47	1050	0.50	1071	0.53	1093	0.57
1680*	916	0.32	943	0.35	970	0.38	995	0.41	1020	0.45	1044	0.48	1067	0.52	1089	0.55	1112	0.59	1133	0.62
1920	960	0.36	986	0.40	1013	0.43	1038	0.46	1062	0.50	1085	0.54	1108	0.57	1131	0.61	1153	0.65	1175	0.69
2160	1004	0.41	1031	0.45	1057	0.48	1082	0.52	1106	0.56	1129	0.59	1152	0.63	1173	0.67	1194	0.71	1216	0.75
2400	1051	0.47	1077	0.50	1102	0.54	1126	0.58	1150	0.62	1173	0.66	1195	0.70	1217	0.74	1238	0.78	1259	0.83
2640	1098	0.52	1123	0.56	1148	0.61	1172	0.65	1195	0.69	1218	0.73	1240	0.77	1261	0.82	1282	0.86	1303	0.91
2880	1147	0.59	1171	0.63	1195	0.68	1219	0.72	1242	0.76	1264	0.81	1286	0.85	1307	0.90	1328	0.95	1348	0.99

**Notes:**

1. For direct drive evaporator fan speed (rpm), refer to the applicable table in the fan performance section.
2. Data includes pressure drop due to standard filters and wet coils.
3. To determine static pressure drop due to other options/accessories, refer to the applicable table in the fan performance section.
4. Direct drive fan motor heat (MBh) = 2.7912 x fan bhp + 0.1388
5. Factory supplied motors, in commercial equipment, are definite purpose motors, specifically designed and tested to operate reliably and continuously at all cataloged conditions. Using the full horsepower range of our fan motors as shown in our tabular data will not result in nuisance tripping or premature motor failure. Our product's warranty will not be affected.
6. \* For 1200, 1440, and 1680 cfm, unit application below 320 cfm/ton are only applicable on T\_C models only (no gas heat). See below for restrictions.
7. \* For electric heat applications, minimum airflow is set to 320 cfm/ton, unless specified otherwise, values found in electric heat temperature rise table.
8. \* TXV with Froststat™ and crankcase heaters are required on applications below 320 cfm/ton.



## Evaporator Fan Performance – High Efficiency

**Table 119. Direct drive evaporator fan performance – 6 tons high efficiency – YHC074F3,F4 low & medium gas heat, downflow airflow**

External Static Pressure (Inches of Water Gauge)																					
0.10"		0.20"		0.30"		0.40"		0.50"		0.60"		0.70"		0.80"		0.90"		1.00"			
CFM	RPM	BHP	RPM	BHP	RPM	BHP	RPM	BHP	RPM	BHP	RPM	BHP	RPM	BHP	RPM	BHP	RPM	BHP	RPM	BHP	
1920	625	0.15	678	0.20	727	0.25	770	0.30	810	0.35	847	0.41	882	0.46	915	0.52	947	0.58	976	0.64	
2160	691	0.20	737	0.25	784	0.31	826	0.37	864	0.42	900	0.48	934	0.54	966	0.61	997	0.67	1026	0.73	
2400	757	0.26	799	0.32	842	0.38	882	0.44	919	0.51	955	0.57	987	0.64	1018	0.70	1049	0.77	1077	0.84	
2640	824	0.34	864	0.40	901	0.46	941	0.53	977	0.60	1010	0.67	1042	0.74	1073	0.81	1101	0.88	1129	0.96	
2880	892	0.42	929	0.49	963	0.55	999	0.63	1034	0.71	1067	0.78	1098	0.86	1127	0.94	1155	1.01	1183	1.09	
External Static Pressure (Inches of Water Gauge)																					
1.10"		1.20"		1.30"		1.40"		1.50"		1.60"		1.70"		1.80"		1.90"		2.00"			
CFM	RPM	BHP	RPM	BHP	RPM	BHP	RPM	BHP	RPM	BHP	RPM	BHP	RPM	BHP	RPM	BHP	RPM	BHP	RPM	BHP	
1920	1005	0.70	1033	0.76	1060	0.83	1086	0.89	1111	0.96	1135	1.03	1158	1.09	1181	1.17	1203	1.23	1225	1.31	
2160	1054	0.80	1082	0.87	1107	0.93	1133	1.00	1158	1.08	1182	1.15	1205	1.22	1228	1.29	1250	1.37	1272	1.45	
2400	1105	0.91	1131	0.98	1157	1.05	1182	1.13	1206	1.20	1229	1.28	1252	1.35	1275	1.43	1297	1.51	1318	1.59	
2640	1156	1.03	1183	1.11	1208	1.19	1232	1.27	1255	1.34	1279	1.42	1302	1.51	1323	1.59	1344	1.67	1365	1.75	
2880	1209	1.17	1234	1.25	1259	1.34	1283	1.42	1306	1.50	1330	1.59	1351	1.67	1373	1.76	1394	1.84	1414	1.93	

**Notes:**

1. For direct drive evaporator fan speed (rpm), refer to the applicable table in the fan performance section.
2. Data includes pressure drop due to standard filters and wet coils.
3. To determine static pressure drop due to other options/accessories, refer to the applicable table in the fan performance section.
4. Direct drive fan motor heat (MBh) = 2.7912 x fan bhp + 0.1388
5. Factory supplied motors, in commercial equipment, are definite purpose motors, specifically designed and tested to operate reliably and continuously at all cataloged conditions. Using the full horsepower range of our fan motors as shown in our tabular data will not result in nuisance tripping or premature motor failure. Our product's warranty will not be affected.

## Evaporator Fan Performance – High Efficiency

**Table 120. Direct drive evaporator fan performance – 6 tons high efficiency – YHC074F3,F4 low & medium gas heat, horizontal airflow**

External Static Pressure (Inches of Water Gauge)																						
		0.10"		0.20"		0.30"		0.40"		0.50"		0.60"		0.70"		0.80"		0.90"		1.00"		
CFM	RPM	BHP	RPM	BHP	RPM	BHP	RPM	BHP	RPM	BHP	RPM	BHP	RPM	BHP	RPM	BHP	RPM	BHP	RPM	BHP	RPM	BHP
1920	583	0.07	638	0.10	686	0.12	729	0.15	768	0.18	805	0.21	839	0.24	871	0.27	902	0.30	931	0.33		
2160	642	0.09	693	0.12	739	0.15	780	0.18	818	0.21	853	0.24	887	0.28	918	0.31	948	0.34	977	0.38		
2400	702	0.11	750	0.15	793	0.19	832	0.22	869	0.25	903	0.29	935	0.32	966	0.35	996	0.39	1023	0.43		
2640	762	0.14	807	0.19	848	0.23	886	0.26	921	0.30	954	0.33	986	0.37	1015	0.41	1043	0.45	1071	0.48		
2880	823	0.17	865	0.22	904	0.27	940	0.31	974	0.35	1006	0.39	1037	0.43	1066	0.47	1094	0.51	1121	0.55		
External Static Pressure (Inches of Water Gauge)																						
		1.10"		1.20"		1.30"		1.40"		1.50"		1.60"		1.70"		1.80"		1.90"		2.00"		
CFM	RPM	BHP	RPM	BHP	RPM	BHP	RPM	BHP	RPM	BHP	RPM	BHP	RPM	BHP	RPM	BHP	RPM	BHP	RPM	BHP	RPM	BHP
1920	960	0.36	986	0.40	1013	0.43	1038	0.46	1062	0.50	1085	0.54	1108	0.57	1131	0.61	1153	0.65	1175	0.69		
2160	1004	0.41	1031	0.45	1057	0.48	1082	0.52	1106	0.56	1129	0.59	1152	0.63	1173	0.67	1194	0.71	1216	0.75		
2400	1051	0.47	1077	0.50	1102	0.54	1126	0.58	1150	0.62	1173	0.66	1195	0.70	1217	0.74	1238	0.78	1259	0.83		
2640	1098	0.52	1123	0.56	1148	0.61	1172	0.65	1195	0.69	1218	0.73	1240	0.77	1261	0.82	1282	0.86	1303	0.91		
2880	1147	0.59	1171	0.63	1195	0.68	1219	0.72	1242	0.76	1264	0.81	1286	0.85	1307	0.90	1328	0.95	1348	0.99		

**Notes:**

1. For direct drive evaporator fan speed (rpm), refer to the applicable table in the fan performance section.
2. Data includes pressure drop due to standard filters and wet coils.
3. To determine static pressure drop due to other options/accessories, refer to the applicable table in the fan performance section.
4. Direct drive fan motor heat (MBh) = 2.7912 x fan bhp + 0.1388
5. Factory supplied motors, in commercial equipment, are definite purpose motors, specifically designed and tested to operate reliably and continuously at all cataloged conditions. Using the full horsepower range of our fan motors as shown in our tabular data will not result in nuisance tripping or premature motor failure. Our product's warranty will not be affected.



## Evaporator Fan Performance – High Efficiency

**Table 121. Direct drive evaporator fan performance – 6 tons high efficiency – YHC074F3,F4 high gas heat, downflow airflow**

External Static Pressure (Inches of Water Gauge)																						
		0.10"		0.20"		0.30"		0.40"		0.50"		0.60"		0.70"		0.80"		0.90"		1.00"		
CFM	RPM	BHP	RPM	BHP	RPM	BHP	RPM	BHP	RPM	BHP	RPM	BHP	RPM	BHP	RPM	BHP	RPM	BHP	RPM	BHP	RPM	BHP
1920	611	0.15	665	0.20	709	0.25	759	0.31	800	0.36	839	0.41	877	0.47	915	0.53	949	0.59	982	0.66		
2160	674	0.20	724	0.26	765	0.31	807	0.37	851	0.43	888	0.49	922	0.55	959	0.62	992	0.68	1025	0.75		
2400	739	0.26	783	0.32	826	0.39	860	0.44	899	0.51	938	0.58	974	0.65	1006	0.71	1037	0.78	1068	0.85		
2640	804	0.34	844	0.40	886	0.47	920	0.54	951	0.60	987	0.67	1024	0.75	1058	0.83	1087	0.90	1114	0.97		
2880	870	0.42	907	0.49	944	0.57	982	0.64	1011	0.71	1039	0.78	1073	0.86	1106	0.95	1138	1.04	1167	1.12		
External Static Pressure (Inches of Water Gauge)																						
		1.10"		1.20"		1.30"		1.40"		1.50"		1.60"		1.70"		1.80"		1.90"		2.00"		
CFM	RPM	BHP	RPM	BHP	RPM	BHP	RPM	BHP	RPM	BHP	RPM	BHP	RPM	BHP	RPM	BHP	RPM	BHP	RPM	BHP	RPM	BHP
1920	1014	0.72	1044	0.78	1073	0.85	1101	0.91	1128	0.98	1155	1.05	1180	1.11	1205	1.18	1230	1.26	1253	1.33		
2160	1056	0.82	1085	0.89	1114	0.96	1142	1.03	1170	1.10	1195	1.17	1221	1.25	1246	1.32	1270	1.40	1293	1.47		
2400	1098	0.93	1128	1.00	1156	1.08	1184	1.15	1210	1.23	1237	1.31	1262	1.39	1287	1.47	1310	1.55	1334	1.63		
2640	1144	1.05	1173	1.13	1201	1.21	1228	1.29	1253	1.38	1279	1.46	1304	1.54	1329	1.63	1352	1.72	1375	1.80		
2880	1193	1.19	1219	1.27	1245	1.35	1272	1.44	1298	1.53	1322	1.62	1348	1.71	1372	1.80	1395	1.89	1418	1.99		

**Notes:**

1. For direct drive evaporator fan speed (rpm), refer to the applicable table in the fan performance section.
2. Data includes pressure drop due to standard filters and wet coils.
3. To determine static pressure drop due to other options/accessories, refer to the applicable table in the fan performance section.
4. Direct drive fan motor heat (MBh) = 2.7912 x fan bhp + 0.1388
5. Factory supplied motors, in commercial equipment, are definite purpose motors, specifically designed and tested to operate reliably and continuously at all cataloged conditions. Using the full horsepower range of our fan motors as shown in our tabular data will not result in nuisance tripping or premature motor failure. Our product's warranty will not be affected.



## Evaporator Fan Performance – High Efficiency

**Table 122. Direct drive evaporator fan performance – 6 tons high efficiency – YHC074F3,F4 high gas heat, horizontal airflow**

External Static Pressure (Inches of Water Gauge)																						
		0.10"		0.20"		0.30"		0.40"		0.50"		0.60"		0.70"		0.80"		0.90"		1.00"		
CFM	RPM	BHP	RPM	BHP	RPM	BHP	RPM	BHP	RPM	BHP	RPM	BHP	RPM	BHP	RPM	BHP	RPM	BHP	RPM	BHP	RPM	BHP
1920	601	0.14	657	0.19	707	0.24	754	0.29	797	0.35	839	0.41	879	0.47	916	0.53	951	0.59	984	0.66		
2160	663	0.18	712	0.24	762	0.30	804	0.35	846	0.41	884	0.47	922	0.54	958	0.61	993	0.68	1026	0.74		
2400	725	0.24	770	0.29	816	0.36	858	0.43	896	0.49	933	0.55	969	0.62	1003	0.69	1036	0.76	1069	0.84		
2640	789	0.30	831	0.36	871	0.43	913	0.51	950	0.58	983	0.64	1018	0.72	1052	0.80	1082	0.87	1112	0.95		
2880	852	0.38	892	0.45	929	0.52	966	0.59	1004	0.68	1038	0.76	1069	0.83	1101	0.91	1131	0.99	1161	1.07		
External Static Pressure (Inches of Water Gauge)																						
		1.10"		1.20"		1.30"		1.40"		1.50"		1.60"		1.70"		1.80"		1.90"		2.00"		
CFM	RPM	BHP	RPM	BHP	RPM	BHP	RPM	BHP	RPM	BHP	RPM	BHP	RPM	BHP	RPM	BHP	RPM	BHP	RPM	BHP	RPM	BHP
1920	1016	0.72	1047	0.79	1078	0.87	1106	0.94	1134	1.01	1162	1.09	1187	1.16	1213	1.24	1237	1.31	1261	1.39		
2160	1058	0.82	1089	0.89	1117	0.96	1146	1.04	1173	1.12	1201	1.20	1227	1.28	1252	1.36	1276	1.44	1300	1.52		
2400	1100	0.92	1130	0.99	1159	1.07	1187	1.15	1214	1.24	1241	1.32	1266	1.40	1292	1.49	1316	1.58	1339	1.66		
2640	1143	1.03	1173	1.11	1201	1.19	1230	1.28	1256	1.37	1282	1.45	1308	1.54	1332	1.63	1356	1.72	1379	1.81		
2880	1189	1.15	1216	1.24	1245	1.33	1271	1.41	1298	1.51	1324	1.60	1349	1.69	1374	1.79	1398	1.88	1421	1.98		

**Notes:**

1. For direct drive evaporator fan speed (rpm), refer to the applicable table in the fan performance section.
2. Data includes pressure drop due to standard filters and wet coils.
3. To determine static pressure drop due to other options/accessories, refer to the applicable table in the fan performance section.
4. Direct drive fan motor heat (MBh) = 2.7912 x fan bhp + 0.1388
5. Factory supplied motors, in commercial equipment, are definite purpose motors, specifically designed and tested to operate reliably and continuously at all cataloged conditions. Using the full horsepower range of our fan motors as shown in our tabular data will not result in nuisance tripping or premature motor failure. Our product's warranty will not be affected.



## Evaporator Fan Performance – High Efficiency

**Table 123. Direct drive evaporator fan performance - 7.5 tons high efficiency - THC092F3,F4,FW downflow airflow**

CFM	External Static Pressure (Inches of Water Gauge)																			
	0.10"		0.20"		0.30"		0.40"		0.50"		0.60"		0.70"		0.80"		0.90"		1.00"	
	RPM	BHP	RPM	BHP	RPM	BHP	RPM	BHP	RPM	BHP	RPM	BHP	RPM	BHP	RPM	BHP	RPM	BHP	RPM	BHP
1500*	484	0.06	543	0.09	593	0.12	637	0.16	677	0.20	714	0.24	749	0.28	781	0.32	812	0.37	841	0.41
1800*	557	0.08	610	0.12	657	0.16	699	0.20	737	0.24	773	0.29	806	0.33	838	0.38	868	0.43	896	0.48
2100*	631	0.12	680	0.16	724	0.20	763	0.25	800	0.30	834	0.34	867	0.39	897	0.45	926	0.50	954	0.55
2400	706	0.17	752	0.21	792	0.26	830	0.31	865	0.36	897	0.41	928	0.47	958	0.52	987	0.58	1013	0.64
2700	784	0.22	825	0.27	863	0.33	898	0.38	932	0.44	963	0.49	993	0.55	1021	0.61	1049	0.67	1075	0.74
3000	862	0.29	900	0.35	936	0.41	969	0.46	1001	0.53	1031	0.59	1059	0.65	1086	0.72	1113	0.78	1138	0.85
3300	941	0.37	975	0.44	1009	0.50	1040	0.56	1070	0.63	1099	0.70	1127	0.76	1153	0.83	1178	0.90	1203	0.97
3600	1021	0.47	1052	0.54	1083	0.61	1113	0.68	1142	0.75	1169	0.82	1195	0.89	1221	0.97	1245	1.04	1268	1.12
	External Static Pressure (Inches of Water Gauge)																			
	1.10"		1.20"		1.30"		1.40"		1.50"		1.60"		1.70"		1.80"		1.90"		2.00"	
	RPM	BHP	RPM	BHP	RPM	BHP	RPM	BHP	RPM	BHP	RPM	BHP	RPM	BHP	RPM	BHP	RPM	BHP	RPM	BHP
1500*	869	0.46	896	0.51	922	0.56	947	0.61	971	0.67	993	0.72	1016	0.77	1039	0.83	1060	0.89	1081	0.95
1800*	924	0.53	950	0.58	976	0.64	1000	0.69	1023	0.75	1047	0.81	1069	0.87	1091	0.93	1111	0.98	1132	1.05
2100*	980	0.61	1006	0.67	1031	0.72	1055	0.78	1078	0.84	1100	0.90	1123	0.97	1144	1.03	1165	1.10	1185	1.16
2400	1039	0.70	1065	0.76	1089	0.82	1112	0.88	1135	0.95	1157	1.01	1178	1.08	1199	1.15	1221	1.22	1240	1.28
2700	1100	0.80	1125	0.87	1148	0.93	1171	1.00	1193	1.07	1215	1.14	1236	1.21	1257	1.28	1276	1.35	1296	1.42
3000	1162	0.91	1187	0.99	1209	1.05	1232	1.13	1254	1.20	1275	1.27	1295	1.35	1315	1.42	1335	1.50	1354	1.58
3300	1227	1.05	1249	1.12	1272	1.20	1293	1.27	1314	1.35	1335	1.43	1356	1.50	1376	1.59	1396	1.67	1415	1.75
3600	1292	1.20	1315	1.27	1335	1.35	1357	1.43	1377	1.51	1398	1.60	1418	1.68	1437	1.76	1457	1.85	1475	1.93

**Notes:**

1. For direct drive evaporator fan speed (rpm), refer to the applicable table in the fan performance section.
2. Data includes pressure drop due to standard filters and wet coils.
3. To determine static pressure drop due to other options/accessories, refer to the applicable table in the fan performance section.
4. Direct drive fan motor heat (MBh) = 2.7912 x fan bhp + 0.1388
5. Factory supplied motors, in commercial equipment, are definite purpose motors, specifically designed and tested to operate reliably and continuously at all cataloged conditions. Using the full horsepower range of our fan motors as shown in our tabular data will not result in nuisance tripping or premature motor failure. Our product's warranty will not be affected.
6. \* For 1500, 1800, and 2100 cfm, unit application below 320 cfm/ton are only applicable on T\_C models only (no gas heat). See below for restrictions.
7. \* For electric heat applications, minimum airflow is set to 320 cfm/ton, unless specified otherwise, values found in electric heat temperature rise table.
8. \*Dehumidification (hot gas reheat) or TXV with Frostat™ and crankcase heaters are required on applications below 320 cfm/ton.

## Evaporator Fan Performance — High Efficiency

**Table 124. Direct drive evaporator fan performance - 7.5 tons high efficiency - THC092F3,F4,FW horizontal airflow**

External Static Pressure (Inches of Water Gauge)																				
	0.10"		0.20"		0.30"		0.40"		0.50"		0.60"		0.70"		0.80"		0.90"		1.00"	
CFM	RPM	BHP	RPM	BHP	RPM	BHP	RPM	BHP	RPM	BHP	RPM	BHP	RPM	BHP	RPM	BHP	RPM	BHP	RPM	BHP
1500*	479	0.07	542	0.11	596	0.14	644	0.19	688	0.23	727	0.27	764	0.32	799	0.37	832	0.42	863	0.47
1800*	548	0.10	605	0.14	656	0.19	701	0.23	744	0.28	782	0.33	818	0.38	852	0.44	884	0.49	915	0.55
2100*	621	0.14	673	0.19	718	0.24	762	0.30	802	0.35	839	0.40	874	0.46	907	0.52	938	0.58	968	0.64
2400	697	0.20	741	0.25	785	0.31	823	0.37	862	0.43	898	0.49	932	0.55	964	0.61	994	0.68	1024	0.74
2700	772	0.27	813	0.33	853	0.39	890	0.45	924	0.52	959	0.59	992	0.66	1023	0.72	1052	0.79	1081	0.86
3000	849	0.35	886	0.42	921	0.49	958	0.55	991	0.63	1022	0.70	1053	0.78	1083	0.85	1112	0.93	1140	1.00
3300	926	0.45	961	0.53	993	0.60	1026	0.67	1060	0.74	1089	0.83	1117	0.91	1145	0.99	1173	1.08	1200	1.16
3600	1004	0.58	1037	0.65	1067	0.73	1096	0.81	1126	0.89	1157	0.97	1184	1.06	1210	1.15	1235	1.24	1262	1.34
External Static Pressure (Inches of Water Gauge)																				
	1.10"		1.20"		1.30"		1.40"		1.50"		1.60"		1.70"		1.80"		1.90"		2.00"	
CFM	RPM	BHP	RPM	BHP	RPM	BHP	RPM	BHP	RPM	BHP	RPM	BHP	RPM	BHP	RPM	BHP	RPM	BHP	RPM	BHP
1500*	893	0.52	921	0.57	949	0.63	975	0.68	1001	0.74	1026	0.80	1050	0.86	1073	0.92	1096	0.98	1118	1.05
1800*	944	0.60	972	0.66	999	0.72	1025	0.78	1051	0.84	1076	0.91	1100	0.97	1122	1.04	1145	1.11	1167	1.17
2100*	997	0.70	1024	0.76	1051	0.83	1077	0.89	1102	0.96	1126	1.03	1150	1.10	1172	1.17	1195	1.24	1217	1.31
2400	1051	0.81	1079	0.88	1105	0.95	1130	1.02	1154	1.09	1179	1.16	1202	1.24	1225	1.31	1246	1.39	1268	1.46
2700	1109	0.94	1135	1.01	1161	1.08	1185	1.16	1210	1.24	1233	1.31	1256	1.39	1278	1.47	1299	1.55	1321	1.64
3000	1167	1.08	1193	1.16	1217	1.24	1241	1.32	1266	1.40	1287	1.48	1310	1.56	1333	1.65	1354	1.74	1375	1.83
3300	1226	1.24	1251	1.33	1275	1.41	1299	1.49	1322	1.58	1345	1.67	1367	1.76	1388	1.85	1410	1.94	1430	2.03
3600	1286	1.42	1312	1.51	1335	1.60	1359	1.70	1381	1.79	1403	1.88	1425	1.98	1446	2.07	1467	2.17	1487	2.26

**Notes:**

1. For direct drive evaporator fan speed (rpm), refer to the applicable table in the fan performance section.
2. Data includes pressure drop due to standard filters and wet coils.
3. To determine static pressure drop due to other options/accessories, refer to the applicable table in the fan performance section.
4. Direct drive fan motor heat (MBh) = 2.7912 x fan bhp + 0.1388
5. Factory supplied motors, in commercial equipment, are definite purpose motors, specifically designed and tested to operate reliably and continuously at all cataloged conditions. Using the full horsepower range of our fan motors as shown in our tabular data will not result in nuisance tripping or premature motor failure. Our product's warranty will not be affected.
6. \* For 1500, 1800, and 2100 cfm, unit application below 320 cfm/ton are only applicable on T\_C models only (no gas heat). See below for restrictions.
7. \* For electric heat applications, minimum airflow is set to 320 cfm/ton, unless specified otherwise, values found in electric heat temperature rise table.
8. \*Dehumidification (hot gas reheat) or TXV with Froststat™ and crankcase heaters are required on applications below 320 cfm/ton.



## Evaporator Fan Performance – High Efficiency

**Table 125. Direct drive evaporator fan performance – 7.5 tons high efficiency – YHC092F3,F4,FW low & medium gas heat, downflow airflow**

External Static Pressure (Inches of Water Gauge)																						
		0.10"		0.20"		0.30"		0.40"		0.50"		0.60"		0.70"		0.80"		0.90"		1.00"		
CFM	RPM	BHP	RPM	BHP	RPM	BHP	RPM	BHP	RPM	BHP	RPM	BHP	RPM	BHP	RPM	BHP	RPM	BHP	RPM	BHP	RPM	BHP
2400	742	0.24	786	0.30	826	0.36	869	0.42	906	0.48	942	0.55	975	0.61	1006	0.68	1036	0.74	1065	0.81		
2700	823	0.33	864	0.39	900	0.45	938	0.52	975	0.59	1009	0.66	1041	0.73	1071	0.81	1100	0.88	1129	0.95		
3000	905	0.43	944	0.51	978	0.57	1009	0.64	1045	0.72	1078	0.80	1109	0.88	1138	0.96	1166	1.04	1194	1.12		
3300	988	0.55	1025	0.64	1057	0.72	1086	0.79	1115	0.87	1147	0.96	1178	1.05	1206	1.13	1234	1.22	1260	1.30		
3600	1071	0.70	1105	0.80	1137	0.89	1165	0.97	1192	1.05	1218	1.13	1248	1.23	1276	1.33	1303	1.42	1328	1.51		
External Static Pressure (Inches of Water Gauge)																						
		1.10"		1.20"		1.30"		1.40"		1.50"		1.60"		1.70"		1.80"		1.90"		2.00"		
CFM	RPM	BHP	RPM	BHP	RPM	BHP	RPM	BHP	RPM	BHP	RPM	BHP	RPM	BHP	RPM	BHP	RPM	BHP	RPM	BHP	RPM	BHP
2400	1093	0.88	1119	0.95	1145	1.02	1171	1.10	1195	1.17	1219	1.25	1241	1.32	1264	1.40	1286	1.48	1308	1.56		
2700	1156	1.03	1181	1.10	1207	1.18	1232	1.26	1255	1.34	1278	1.42	1301	1.50	1323	1.58	1344	1.67	1365	1.75		
3000	1219	1.20	1245	1.28	1270	1.36	1294	1.45	1318	1.53	1340	1.62	1362	1.71	1384	1.79	1406	1.88	1426	1.97		
3300	1286	1.39	1310	1.48	1335	1.57	1358	1.66	1381	1.75	1403	1.84	1425	1.93	1446	2.03	1467	2.12	1487	2.21		
3600	1353	1.61	1377	1.70	1400	1.79	1424	1.89	1445	1.99	1467	2.08	1488	2.18	1509	2.28	1530	2.38	1550	2.49		

**Notes:**

1. For direct drive evaporator fan speed (rpm), refer to the applicable table in the fan performance section.
2. Data includes pressure drop due to standard filters and wet coils.
3. To determine static pressure drop due to other options/accessories, refer to the applicable table in the fan performance section.
4. Direct drive fan motor heat (MBh) = 2.7912 x fan bhp + 0.1388
5. Factory supplied motors, in commercial equipment, are definite purpose motors, specifically designed and tested to operate reliably and continuously at all cataloged conditions. Using the full horsepower range of our fan motors as shown in our tabular data will not result in nuisance tripping or premature motor failure. Our product's warranty will not be affected.

## Evaporator Fan Performance – High Efficiency

**Table 126. Direct drive evaporator fan performance – 7.5 tons high efficiency – YHC092F3,F4,FW low & medium gas heat, horizontal airflow**

External Static Pressure (Inches of Water Gauge)																						
		0.10"		0.20"		0.30"		0.40"		0.50"		0.60"		0.70"		0.80"		0.90"		1.00"		
CFM	RPM	BHP	RPM	BHP	RPM	BHP	RPM	BHP	RPM	BHP	RPM	BHP	RPM	BHP	RPM	BHP	RPM	BHP	RPM	BHP	RPM	BHP
2400	718	0.22	762	0.27	805	0.33	844	0.39	881	0.45	915	0.51	947	0.57	978	0.64	1007	0.70	1035	0.77		
2700	796	0.30	836	0.36	875	0.42	913	0.49	947	0.55	980	0.62	1011	0.69	1041	0.76	1069	0.83	1096	0.90		
3000	876	0.39	913	0.46	948	0.53	983	0.60	1016	0.67	1047	0.75	1077	0.82	1106	0.90	1133	0.97	1160	1.05		
3300	956	0.51	990	0.58	1022	0.65	1055	0.73	1086	0.81	1116	0.89	1145	0.98	1172	1.06	1198	1.14	1224	1.22		
3600	1037	0.64	1069	0.73	1099	0.81	1128	0.88	1157	0.96	1186	1.05	1213	1.14	1240	1.23	1266	1.33	1290	1.41		
External Static Pressure (Inches of Water Gauge)																						
		1.10"		1.20"		1.30"		1.40"		1.50"		1.60"		1.70"		1.80"		1.90"		2.00"		
CFM	RPM	BHP	RPM	BHP	RPM	BHP	RPM	BHP	RPM	BHP	RPM	BHP	RPM	BHP	RPM	BHP	RPM	BHP	RPM	BHP	RPM	BHP
2400	1062	0.84	1089	0.91	1114	0.98	1138	1.05	1162	1.12	1185	1.19	1208	1.27	1230	1.34	1250	1.41	1271	1.49		
2700	1123	0.97	1149	1.05	1173	1.12	1197	1.2	1220	1.28	1243	1.35	1266	1.43	1287	1.51	1307	1.59	1329	1.68		
3000	1185	1.13	1210	1.21	1234	1.29	1257	1.37	1280	1.45	1302	1.53	1324	1.62	1345	1.71	1366	1.79	1386	1.88		
3300	1249	1.3	1273	1.39	1297	1.47	1319	1.56	1342	1.65	1363	1.74	1384	1.83	1406	1.92	1425	2.01	1445	2.1		
3600	1314	1.5	1338	1.59	1361	1.69	1383	1.78	1405	1.87	1425	1.96	1446	2.06	1467	2.16	1487	2.26	1506	2.35		

**Notes:**

1. For direct drive evaporator fan speed (rpm), refer to the applicable table in the fan performance section.
2. Data includes pressure drop due to standard filters and wet coils.
3. To determine static pressure drop due to other options/accessories, refer to the applicable table in the fan performance section.
4. Direct drive fan motor heat (MBh) = 2.7912 x fan bhp + 0.1388
5. Factory supplied motors, in commercial equipment, are definite purpose motors, specifically designed and tested to operate reliably and continuously at all cataloged conditions. Using the full horsepower range of our fan motors as shown in our tabular data will not result in nuisance tripping or premature motor failure. Our product's warranty will not be affected.



## Evaporator Fan Performance – High Efficiency

**Table 127. Direct drive evaporator fan performance – 7.5 tons high efficiency – YHC092F3,F4,FW high gas heat, downflow airflow**

External Static Pressure (Inches of Water Gauge)																						
		0.10"		0.20"		0.30"		0.40"		0.50"		0.60"		0.70"		0.80"		0.90"		1.00"		
CFM	RPM	BHP	RPM	BHP	RPM	BHP	RPM	BHP	RPM	BHP	RPM	BHP	RPM	BHP	RPM	BHP	RPM	BHP	RPM	BHP	RPM	BHP
2400	759	0.29	800	0.34	845	0.41	884	0.47	920	0.53	956	0.60	989	0.66	1022	0.73	1053	0.80	1083	0.87		
2700	844	0.39	879	0.45	918	0.52	958	0.60	992	0.66	1024	0.74	1057	0.81	1087	0.88	1117	0.95	1145	1.03		
3000	931	0.52	962	0.59	995	0.66	1031	0.74	1067	0.82	1098	0.90	1127	0.98	1156	1.06	1184	1.14	1211	1.22		
3300	1018	0.68	1046	0.75	1075	0.82	1107	0.91	1140	1.00	1172	1.09	1201	1.17	1227	1.26	1254	1.35	1279	1.43		
3600	1106	0.87	1132	0.95	1157	1.02	1185	1.11	1215	1.21	1245	1.30	1275	1.40	1301	1.49	1326	1.59	1350	1.68		
External Static Pressure (Inches of Water Gauge)																						
		1.10"		1.20"		1.30"		1.40"		1.50"		1.60"		1.70"		1.80"		1.90"		2.00"		
CFM	RPM	BHP	RPM	BHP	RPM	BHP	RPM	BHP	RPM	BHP	RPM	BHP	RPM	BHP	RPM	BHP	RPM	BHP	RPM	BHP	RPM	BHP
2400	1113	0.94	1141	1.02	1169	1.09	1194	1.17	1220	1.24	1245	1.32	1270	1.4	1292	1.48	1315	1.56	1338	1.64		
2700	1174	1.11	1202	1.19	1228	1.27	1254	1.35	1278	1.43	1303	1.52	1328	1.6	1350	1.68	1373	1.77	1395	1.86		
3000	1238	1.3	1264	1.38	1289	1.47	1314	1.55	1339	1.64	1363	1.73	1386	1.82	1409	1.92	1431	2.01	1454	2.1		
3300	1306	1.52	1330	1.61	1355	1.7	1378	1.79	1402	1.88	1425	1.98	1448	2.08	1470	2.17	1492	2.27	1513	2.37		
3600	1374	1.78	1398	1.87	1422	1.97	1445	2.06	1467	2.16	1489	2.26	1510	2.36	1532	2.46	1553	2.56	1575	2.67		

**Notes:**

1. For direct drive evaporator fan speed (rpm), refer to the applicable table in the fan performance section.
2. Data includes pressure drop due to standard filters and wet coils.
3. To determine static pressure drop due to other options/accessories, refer to the applicable table in the fan performance section.
4. Direct drive fan motor heat (MBh) = 2.7912 x fan bhp + 0.1388
5. Factory supplied motors, in commercial equipment, are definite purpose motors, specifically designed and tested to operate reliably and continuously at all cataloged conditions. Using the full horsepower range of our fan motors as shown in our tabular data will not result in nuisance tripping or premature motor failure. Our product's warranty will not be affected.

## Evaporator Fan Performance – High Efficiency

**Table 128. Direct drive evaporator fan performance – 7.5 tons high efficiency – YHC092F3,F4,FW high gas heat, horizontal airflow**

External Static Pressure (Inches of Water Gauge)																						
		0.10"		0.20"		0.30"		0.40"		0.50"		0.60"		0.70"		0.80"		0.90"		1.00"		
CFM	RPM	BHP	RPM	BHP	RPM	BHP	RPM	BHP	RPM	BHP	RPM	BHP	RPM	BHP	RPM	BHP	RPM	BHP	RPM	BHP	RPM	BHP
2400	719	0.24	765	0.30	811	0.36	853	0.42	883	0.47	888	0.48	981	0.66	1003	0.71	1020	0.75	1033	0.78		
2700	797	0.32	840	0.38	880	0.46	920	0.53	958	0.60	992	0.67	996	0.68	1072	0.85	1107	0.94	1126	1.00		
3000	875	0.42	916	0.49	952	0.57	989	0.65	1025	0.73	1059	0.80	1091	0.89	1105	0.93	1108	0.94	1198	1.19		
3300	955	0.55	993	0.62	1027	0.70	1060	0.79	1093	0.88	1126	0.96	1157	1.05	1186	1.13	1213	1.22	1216	1.24		
3600	1035	0.69	1070	0.77	1103	0.86	1133	0.95	1163	1.05	1194	1.15	1224	1.24	1253	1.33	1280	1.42	1306	1.52		
External Static Pressure (Inches of Water Gauge)																						
		1.10"		1.20"		1.30"		1.40"		1.50"		1.60"		1.70"		1.80"		1.90"		2.00"		
CFM	RPM	BHP	RPM	BHP	RPM	BHP	RPM	BHP	RPM	BHP	RPM	BHP	RPM	BHP	RPM	BHP	RPM	BHP	RPM	BHP	RPM	BHP
2400	1045	0.81	1055	0.84	1065	0.87	1074	0.9	1083	0.92	1091	0.95	1099	0.97	1106	1	1113	1.02	1119	1.04		
2700	1142	1.04	1154	1.09	1166	1.12	1176	1.16	1186	1.19	1195	1.22	1203	1.26	1211	1.28	1218	1.31	1226	1.34		
3000	1228	1.29	1247	1.35	1261	1.40	1274	1.45	1285	1.5	1295	1.54	1304	1.58	1313	1.61	1321	1.65	1329	1.69		
3300	1220	1.25	1314	1.57	1345	1.69	1363	1.76	1377	1.83	1391	1.89	1402	1.94	1412	1.98	1421	2.03	1430	2.08		
3600	1324	1.59	1327	1.61	1330	1.63	1333	1.64	1456	2.14	1476	2.24	1492	2.31	1505	2.38	1516	2.44	1527	2.5		

**Notes:**

1. For direct drive evaporator fan speed (rpm), refer to the applicable table in the fan performance section.
2. Data includes pressure drop due to standard filters and wet coils.
3. To determine static pressure drop due to other options/accessories, refer to the applicable table in the fan performance section.
4. Direct drive fan motor heat (MBh) = 2.7912 x fan bhp + 0.1388
5. Factory supplied motors, in commercial equipment, are definite purpose motors, specifically designed and tested to operate reliably and continuously at all cataloged conditions. Using the full horsepower range of our fan motors as shown in our tabular data will not result in nuisance tripping or premature motor failure. Our product's warranty will not be affected.



## Evaporator Fan Performance – High Efficiency

**Table 129. Direct drive evaporator fan performance – 8.5 tons high efficiency – THC102F3,F4,FW downflow airflow**

CFM	External Static Pressure (Inches of Water Gauge)																			
	0.10"		0.20"		0.30"		0.40"		0.50"		0.60"		0.70"		0.80"		0.90"		1.00"	
	RPM	BHP	RPM	BHP	RPM	BHP	RPM	BHP	RPM	BHP	RPM	BHP	RPM	BHP	RPM	BHP	RPM	BHP	RPM	BHP
1700*	536	0.10	596	0.14	652	0.18	701	0.23	747	0.27	789	0.32	829	0.36	866	0.41	901	0.46	935	0.51
2040*	620	0.15	675	0.20	720	0.24	767	0.30	811	0.35	851	0.40	889	0.46	926	0.51	960	0.57	992	0.63
2380*	708	0.21	752	0.27	799	0.33	837	0.38	877	0.44	917	0.50	952	0.57	988	0.63	1021	0.69	1053	0.76
2720	793	0.30	834	0.36	878	0.43	916	0.49	949	0.55	983	0.62	1019	0.69	1052	0.76	1084	0.83	1115	0.90
3060	879	0.40	922	0.48	956	0.54	994	0.62	1028	0.69	1059	0.76	1087	0.83	1119	0.91	1151	1.00	1181	1.08
3400	966	0.53	1011	0.62	1039	0.69	1072	0.77	1107	0.86	1138	0.94	1166	1.02	1192	1.10	1218	1.18	1247	1.27
3740	1056	0.68	1096	0.79	1127	0.87	1153	0.94	1184	1.04	1216	1.14	1244	1.23	1270	1.31	1295	1.40	1318	1.48
4080	1147	0.87	1180	0.97	1216	1.08	1239	1.16	1264	1.25	1294	1.35	1323	1.46	1349	1.56	1373	1.66	1397	1.75
CFM	External Static Pressure (Inches of Water Gauge)																			
	1.10"		1.20"		1.30"		1.40"		1.50"		1.60"		1.70"		1.80"		1.90"		2.00"	
	RPM	BHP	RPM	BHP	RPM	BHP	RPM	BHP	RPM	BHP	RPM	BHP	RPM	BHP	RPM	BHP	RPM	BHP	RPM	BHP
1700*	967	0.56	997	0.61	1026	0.66	1054	0.71	1082	0.76	1108	0.82	1134	0.87	1159	0.92	1184	0.98	1208	1.03
2040*	1023	0.68	1053	0.74	1082	0.8	1111	0.86	1137	0.92	1164	0.98	1189	1.04	1214	1.1	1238	1.16	1262	1.22
2380*	1084	0.82	1112	0.89	1141	0.95	1169	1.02	1195	1.09	1220	1.15	1245	1.22	1271	1.29	1294	1.36	1317	1.43
2720	1144	0.98	1174	1.05	1201	1.13	1228	1.2	1255	1.28	1280	1.35	1304	1.42	1329	1.5	1352	1.58	1374	1.65
3060	1209	1.16	1236	1.23	1263	1.32	1290	1.4	1314	1.48	1340	1.56	1364	1.65	1389	1.73	1412	1.82	1434	1.9
3400	1276	1.36	1303	1.45	1328	1.53	1353	1.62	1378	1.71	1403	1.8	1426	1.89	1449	1.98	1472	2.07	1495	2.17
3740	1343	1.57	1369	1.67	1395	1.78	1421	1.88	1445	1.98	1467	2.07	1490	2.16	1512	2.26	1534	2.36	1557	2.46
4080	1419	1.84	1440	1.94	1462	2.03	1487	2.14	1511	2.25	1534	2.36	1557	2.47	1579	2.57	1601	2.68	1621	2.79

**Notes:**

1. For direct drive evaporator fan speed (rpm), refer to the applicable table in the fan performance section.
2. Data includes pressure drop due to standard filters and wet coils.
3. To determine static pressure drop due to other options/accessories, refer to the applicable table in the fan performance section.
4. Direct drive fan motor heat (MBh) = 2.7912 x fan bhp + 0.1388
5. Factory supplied motors, in commercial equipment, are definite purpose motors, specifically designed and tested to operate reliably and continuously at all cataloged conditions. Using the full horsepower range of our fan motors as shown in our tabular data will not result in nuisance tripping or premature motor failure. Our product's warranty will not be affected.
6. \* For 1700, 2040, and 2380 cfm, unit application below 320 cfm/ton are only applicable on T\_C models only (no gas heat). See below for restrictions.
7. \* For electric heat applications, minimum airflow is set to 320 cfm/ton, unless specified otherwise, values found in electric heat temperature rise table.
8. \*Dehumidification (hot gas reheat) or TXV with Froststat™ and crankcase heaters are required on applications below 320 cfm/ton.



## Evaporator Fan Performance – High Efficiency

**Table 130. Direct drive evaporator fan performance – 8.5 tons high efficiency – THC102F3,F4,FW horizontal airflow**

External Static Pressure (Inches of Water Gauge)																				
	0.10"		0.20"		0.30"		0.40"		0.50"		0.60"		0.70"		0.80"		0.90"		1.00"	
CFM	RPM	BHP	RPM	BHP	RPM	BHP	RPM	BHP	RPM	BHP	RPM	BHP	RPM	BHP	RPM	BHP	RPM	BHP	RPM	BHP
1700*	536	0.10	593	0.14	645	0.18	694	0.23	737	0.27	778	0.32	815	0.37	849	0.42	882	0.47	913	0.52
2040*	617	0.15	672	0.20	717	0.25	761	0.30	804	0.35	842	0.41	878	0.46	912	0.52	944	0.58	974	0.63
2380*	703	0.21	752	0.27	795	0.33	834	0.39	871	0.45	908	0.51	944	0.57	977	0.64	1008	0.70	1038	0.76
2720	792	0.30	833	0.36	875	0.43	912	0.50	946	0.56	978	0.63	1011	0.70	1044	0.77	1075	0.85	1104	0.92
3060	883	0.41	916	0.48	955	0.55	992	0.63	1023	0.70	1054	0.78	1083	0.85	1112	0.93	1141	1.01	1170	1.09
3400	974	0.55	1003	0.62	1036	0.70	1072	0.79	1104	0.87	1132	0.95	1160	1.03	1187	1.11	1213	1.20	1239	1.28
3740	1064	0.72	1092	0.79	1120	0.87	1152	0.97	1183	1.06	1213	1.15	1239	1.24	1264	1.33	1289	1.42	1313	1.51
4080	1154	0.91	1183	1.00	1207	1.08	1234	1.18	1263	1.28	1292	1.38	1320	1.49	1344	1.58	1368	1.68	1390	1.78
External Static Pressure (Inches of Water Gauge)																				
	1.10"		1.20"		1.30"		1.40"		1.50"		1.60"		1.70"		1.80"		1.90"		2.00"	
CFM	RPM	BHP	RPM	BHP	RPM	BHP	RPM	BHP	RPM	BHP	RPM	BHP	RPM	BHP	RPM	BHP	RPM	BHP	RPM	BHP
1700*	943	0.58	972	0.63	1000	0.69	1027	0.75	1053	0.80	1078	0.86	1103	0.92	1126	0.98	1149	1.05	1172	1.11
2040*	1004	0.69	1032	0.75	1060	0.82	1087	0.88	1112	0.94	1136	1.01	1160	1.07	1183	1.14	1207	1.21	1229	1.28
2380*	1067	0.83	1095	0.9	1121	0.97	1147	1.03	1172	1.1	1197	1.17	1221	1.25	1243	1.32	1266	1.39	1287	1.46
2720	1132	0.99	1159	1.06	1185	1.14	1211	1.21	1235	1.29	1258	1.36	1282	1.44	1305	1.52	1326	1.6	1348	1.68
3060	1199	1.18	1225	1.26	1251	1.34	1275	1.42	1299	1.5	1322	1.58	1345	1.66	1368	1.75	1389	1.84	1411	1.92
3400	1265	1.37	1291	1.46	1317	1.56	1342	1.65	1366	1.74	1388	1.83	1411	1.92	1433	2.01	1453	2.10	1475	2.19
3740	1337	1.6	1361	1.7	1384	1.8	1408	1.9	1431	2	1455	2.1	1478	2.2	1499	2.3	1520	2.4	1540	2.5
4080	1412	1.87	1435	1.97	1456	2.07	1478	2.18	1500	2.28	1521	2.39	1544	2.5	1566	2.61	1586	2.72	1607	2.83

**Notes:**

1. For direct drive evaporator fan speed (rpm), refer to the applicable table in the fan performance section.
2. Data includes pressure drop due to standard filters and wet coils.
3. To determine static pressure drop due to other options/accessories, refer to the applicable table in the fan performance section.
4. Direct drive fan motor heat (MBh) = 2.7912 x fan bhp + 0.1388
5. Factory supplied motors, in commercial equipment, are definite purpose motors, specifically designed and tested to operate reliably and continuously at all cataloged conditions. Using the full horsepower range of our fan motors as shown in our tabular data will not result in nuisance tripping or premature motor failure. Our product's warranty will not be affected.
6. \* For 1700, 2040, and 2380 cfm, unit application below 320 cfm/ton are only applicable on T\_C models only (no gas heat). See below for restrictions.
7. \* For electric heat applications, minimum airflow is set to 320 cfm/ton, unless specified otherwise, values found in electric heat temperature rise table.
8. \*Dehumidification (hot gas reheat) or TXV with Froststat™ and crankcase heaters are required on applications below 320 cfm/ton.



## Evaporator Fan Performance – High Efficiency

**Table 131. Direct drive evaporator fan performance – 8.5 tons high efficiency – YHC102F3,F4,FW low & medium gas heat, downflow airflow**

External Static Pressure (Inches of Water Gauge)																						
		0.10"		0.20"		0.30"		0.40"		0.50"		0.60"		0.70"		0.80"		0.90"		1.00"		
CFM	RPM	BHP	RPM	BHP	RPM	BHP	RPM	BHP	RPM	BHP	RPM	BHP	RPM	BHP	RPM	BHP	RPM	BHP	RPM	BHP	RPM	BHP
2720	804	0.27	849	0.31	889	0.36	927	0.42	962	0.47	995	0.52	1027	0.58	1057	0.64	1085	0.70	1113	0.76		
3060	894	0.37	934	0.41	972	0.47	1007	0.53	1040	0.59	1072	0.65	1102	0.71	1131	0.77	1159	0.83	1186	0.90		
3400	984	0.49	1021	0.54	1056	0.60	1090	0.66	1121	0.73	1151	0.80	1180	0.87	1207	0.93	1234	0.99	1260	1.06		
3740	1075	0.64	1110	0.70	1142	0.76	1173	0.82	1203	0.89	1232	0.97	1260	1.05	1286	1.12	1312	1.19	1336	1.26		
4080	1166	0.82	1198	0.88	1229	0.94	1259	1.01	1287	1.09	1314	1.16	1340	1.24	1366	1.33	1390	1.42	1414	1.49		
External Static Pressure (Inches of Water Gauge)																						
		1.10"		1.20"		1.30"		1.40"		1.50"		1.60"		1.70"		1.80"		1.90"		2.00"		
CFM	RPM	BHP	RPM	BHP	RPM	BHP	RPM	BHP	RPM	BHP	RPM	BHP	RPM	BHP	RPM	BHP	RPM	BHP	RPM	BHP	RPM	BHP
2720	1140	0.82	1165	0.87	1191	0.93	1215	0.99	1238	1.05	1261	1.11	1284	1.18	1305	1.25	1327	1.32	1347	1.39		
3060	1211	0.96	1237	1.04	1260	1.1	1284	1.17	1307	1.23	1329	1.29	1351	1.35	1372	1.42	1393	1.49	1414	1.57		
3400	1284	1.13	1309	1.2	1332	1.28	1356	1.36	1378	1.44	1400	1.51	1420	1.58	1442	1.65	1461	1.72	1481	1.79		
3740	1360	1.33	1383	1.4	1406	1.48	1428	1.56	1451	1.64	1472	1.73	1492	1.81	1512	1.9	1532	1.98	1551	2.06		
4080	1437	1.56	1460	1.64	1482	1.72	1503	1.8	1525	1.88	1545	1.97	1565	2.05	1586	2.15	1604	2.23	1623	2.33		

**Notes:**

1. For direct drive evaporator fan speed (rpm), refer to the applicable table in the fan performance section.
2. Data includes pressure drop due to standard filters and wet coils.
3. To determine static pressure drop due to other options/accessories, refer to the applicable table in the fan performance section.
4. Direct drive fan motor heat (MBh) = 2.7912 x fan bhp + 0.1388
5. Factory supplied motors, in commercial equipment, are definite purpose motors, specifically designed and tested to operate reliably and continuously at all cataloged conditions. Using the full horsepower range of our fan motors as shown in our tabular data will not result in nuisance tripping or premature motor failure. Our product's warranty will not be affected.

## Evaporator Fan Performance – High Efficiency

**Table 132. Direct drive evaporator fan performance – 8.5 tons high efficiency – YHC102F3,F4,FW low & medium gas heat, horizontal airflow**

External Static Pressure (Inches of Water Gauge)																					
		0.10"		0.20"		0.30"		0.40"		0.50"		0.60"		0.70"		0.80"		0.90"		1.00"	
CFM	RPM	BHP	RPM	BHP	RPM	BHP	RPM	BHP	RPM	BHP	RPM	BHP	RPM	BHP	RPM	BHP	RPM	BHP	RPM	BHP	
2720	815	0.33	847	0.40	886	0.47	926	0.54	962	0.61	995	0.69	1027	0.76	1058	0.84	1090	0.91	1122	0.99	
3060	909	0.45	938	0.52	968	0.60	1004	0.68	1040	0.76	1072	0.84	1103	0.93	1132	1.01	1160	1.10	1187	1.18	
3400	1003	0.59	1030	0.68	1056	0.76	1085	0.85	1118	0.94	1150	1.03	1179	1.12	1207	1.21	1234	1.30	1261	1.40	
3740	1099	0.77	1123	0.86	1147	0.96	1170	1.05	1198	1.15	1227	1.24	1257	1.34	1285	1.44	1311	1.54	1336	1.64	
4080	1194	0.98	1217	1.08	1239	1.18	1260	1.28	1282	1.39	1308	1.50	1335	1.60	1363	1.71	1388	1.81	1413	1.92	
External Static Pressure (Inches of Water Gauge)																					
		1.10"		1.20"		1.30"		1.40"		1.50"		1.60"		1.70"		1.80"		1.90"		2.00"	
CFM	RPM	BHP	RPM	BHP	RPM	BHP	RPM	BHP	RPM	BHP	RPM	BHP	RPM	BHP	RPM	BHP	RPM	BHP	RPM	BHP	
2720	1154	1.07	1184	1.15	1212	1.23	1238	1.31	1262	1.39	1285	1.47	1307	1.55	1329	1.63	1352	1.71	1373	1.79	
3060	1214	1.27	1244	1.35	1273	1.44	1301	1.53	1327	1.62	1353	1.72	1376	1.8	1398	1.89	1420	1.98	1440	2.07	
3400	1285	1.49	1310	1.59	1335	1.69	1360	1.78	1387	1.87	1412	1.97	1439	2.07	1462	2.17	1486	2.27	1508	2.38	
3740	1361	1.75	1384	1.85	1407	1.96	1430	2.06	1452	2.17	1474	2.27	1498	2.37	1522	2.48	1545	2.58	1569	2.70	
4080	1437	2.03	1460	2.14	1482	2.26	1503	2.37	1524	2.48	1546	2.6	1566	2.71	1587	2.83	1608	2.95	-	-	

**Notes:**

1. For direct drive evaporator fan speed (rpm), refer to the applicable table in the fan performance section.
2. Data includes pressure drop due to standard filters and wet coils.
3. To determine static pressure drop due to other options/accessories, refer to the applicable table in the fan performance section.
4. Direct drive fan motor heat (MBh) = 2.7912 x fan bhp + 0.1388
5. Factory supplied motors, in commercial equipment, are definite purpose motors, specifically designed and tested to operate reliably and continuously at all cataloged conditions. Using the full horsepower range of our fan motors as shown in our tabular data will not result in nuisance tripping or premature motor failure. Our product's warranty will not be affected.



## Evaporator Fan Performance – High Efficiency

**Table 133. Direct drive evaporator fan performance – 8.5 tons high efficiency – YHC102F3,F4,FW high gas heat, downflow airflow**

External Static Pressure (Inches of Water Gauge)																						
		0.10"		0.20"		0.30"		0.40"		0.50"		0.60"		0.70"		0.80"		0.90"		1.00"		
CFM	RPM	BHP	RPM	BHP	RPM	BHP	RPM	BHP	RPM	BHP	RPM	BHP	RPM	BHP	RPM	BHP	RPM	BHP	RPM	BHP	RPM	BHP
2720	850	0.40	884	0.46	923	0.53	963	0.61	998	0.68	1029	0.75	1061	0.82	1091	0.89	1121	0.96	1149	1.04		
3060	948	0.55	978	0.62	1011	0.69	1046	0.77	1081	0.86	1112	0.94	1141	1.02	1169	1.09	1198	1.18	1224	1.26		
3400	1047	0.74	1074	0.81	1102	0.88	1132	0.97	1165	1.07	1196	1.16	1226	1.25	1251	1.34	1277	1.42	1302	1.51		
3740	1147	0.96	1171	1.04	1196	1.12	1222	1.21	1250	1.31	1280	1.42	1309	1.52	1336	1.62	1361	1.72	1384	1.81		
4080	1246	1.23	1269	1.32	1292	1.41	1315	1.50	1339	1.60	1365	1.71	1392	1.82	1419	1.94	1445	2.05	1468	2.15		
External Static Pressure (Inches of Water Gauge)																						
		1.10"		1.20"		1.30"		1.40"		1.50"		1.60"		1.70"		1.80"		1.90"		2.00"		
CFM	RPM	BHP	RPM	BHP	RPM	BHP	RPM	BHP	RPM	BHP	RPM	BHP	RPM	BHP	RPM	BHP	RPM	BHP	RPM	BHP	RPM	BHP
2720	1178	1.12	1205	1.20	1232	1.28	1258	1.37	1283	1.45	1307	1.53	1330	1.62	1354	1.71	1377	1.79	1399	1.88		
3060	1251	1.34	1276	1.43	1302	1.51	1327	1.6	1352	1.69	1376	1.79	1398	1.88	1422	1.97	1444	2.07	1465	2.16		
3400	1327	1.60	1352	1.69	1377	1.79	1400	1.88	1423	1.98	1446	2.07	1468	2.17	1490	2.27	1513	2.38	1533	2.47		
3740	1407	1.91	1431	2.01	1454	2.1	1476	2.2	1498	2.30	1519	2.40	1541	2.51	1562	2.61	1582	2.72	-	-		
4080	1491	2.26	1512	2.36	1533	2.47	1554	2.57	1576	2.68	1597	2.79	-	-	-	-	-	-	-	-		

**Notes:**

1. For direct drive evaporator fan speed (rpm), refer to the applicable table in the fan performance section.
2. Data includes pressure drop due to standard filters and wet coils.
3. To determine static pressure drop due to other options/accessories, refer to the applicable table in the fan performance section.
4. Direct drive fan motor heat (MBh) = 2.7912 x fan bhp + 0.1388
5. Factory supplied motors, in commercial equipment, are definite purpose motors, specifically designed and tested to operate reliably and continuously at all cataloged conditions. Using the full horsepower range of our fan motors as shown in our tabular data will not result in nuisance tripping or premature motor failure. Our product's warranty will not be affected.

## Evaporator Fan Performance – High Efficiency

**Table 134. Direct drive evaporator fan performance – 8.5 tons high efficiency – YHC102F3,F4,FW high gas heat, horizontal airflow**

External Static Pressure (Inches of Water Gauge)																						
		0.10"		0.20"		0.30"		0.40"		0.50"		0.60"		0.70"		0.80"		0.90"		1.00"		
CFM	RPM	BHP	RPM	BHP	RPM	BHP	RPM	BHP	RPM	BHP	RPM	BHP	RPM	BHP	RPM	BHP	RPM	BHP	RPM	BHP	RPM	BHP
2720	817	0.35	858	0.41	897	0.48	937	0.56	975	0.64	1009	0.71	1042	0.78	1073	0.86	1106	0.94	1137	1.02		
3060	908	0.47	947	0.55	980	0.62	1016	0.70	1052	0.79	1086	0.88	1117	0.96	1147	1.04	1176	1.13	1204	1.22		
3400	1001	0.62	1037	0.71	1068	0.79	1099	0.88	1131	0.97	1164	1.07	1195	1.17	1224	1.26	1251	1.35	1277	1.44		
3740	1094	0.81	1127	0.91	1158	1.00	1185	1.09	1214	1.19	1243	1.29	1272	1.39	1301	1.50	1329	1.61	1354	1.71		
4080	1188	1.03	1218	1.14	1248	1.24	1274	1.34	1299	1.44	1325	1.54	1352	1.66	1379	1.77	1406	1.89	1432	2.01		
External Static Pressure (Inches of Water Gauge)																						
		1.10"		1.20"		1.30"		1.40"		1.50"		1.60"		1.70"		1.80"		1.90"		2.00"		
CFM	RPM	BHP	RPM	BHP	RPM	BHP	RPM	BHP	RPM	BHP	RPM	BHP	RPM	BHP	RPM	BHP	RPM	BHP	RPM	BHP	RPM	BHP
2720	1166	1.1	1193	1.18	1220	1.26	1245	1.34	1269	1.42	1294	1.5	1318	1.59	1340	1.67	1364	1.76	1385	1.84		
3060	1233	1.31	1261	1.40	1288	1.49	1314	1.58	1338	1.67	1362	1.76	1384	1.85	1408	1.94	1429	2.03	1450	2.12		
3400	1304	1.54	1329	1.63	1355	1.73	1380	1.83	1406	1.94	1430	2.04	1453	2.14	1475	2.23	1497	2.34	1518	2.43		
3740	1378	1.81	1402	1.91	1426	2.01	1450	2.12	1473	2.22	1496	2.33	1520	2.45	1542	2.55	1565	2.67	1587	2.78		
4080	1457	2.12	1479	2.23	1502	2.34	1524	2.45	1546	2.56	1567	2.68	1590	2.79	-	-	-	-	-	-		

**Notes:**

1. For direct drive evaporator fan speed (rpm), refer to the applicable table in the fan performance section.
2. Data includes pressure drop due to standard filters and wet coils.
3. To determine static pressure drop due to other options/accessories, refer to the applicable table in the fan performance section.
4. Direct drive fan motor heat (MBh) = 2.7912 x fan bhp + 0.1388
5. Factory supplied motors, in commercial equipment, are definite purpose motors, specifically designed and tested to operate reliably and continuously at all cataloged conditions. Using the full horsepower range of our fan motors as shown in our tabular data will not result in nuisance tripping or premature motor failure. Our product's warranty will not be affected.



## Evaporator Fan Performance – High Efficiency

**Table 135. Direct drive evaporator fan performance – 10 tons high efficiency – THC120F3,F4 downflow airflow**

CFM	External Static Pressure (Inches of Water Gauge)																			
	0.10"		0.20"		0.30"		0.40"		0.50"		0.60"		0.70"		0.80"		0.90"		1.00"	
	RPM	BHP	RPM	BHP	RPM	BHP	RPM	BHP	RPM	BHP	RPM	BHP	RPM	BHP	RPM	BHP	RPM	BHP	RPM	BHP
2000*	593	0.12	650	0.18	702	0.23	748	0.29	791	0.35	831	0.40	868	0.46	904	0.52	938	0.59	970	0.65
2400*	699	0.20	732	0.24	785	0.31	827	0.38	870	0.45	907	0.51	942	0.58	976	0.65	1009	0.72	1040	0.80
2800*	800	0.30	830	0.34	873	0.41	913	0.49	947	0.56	987	0.65	1022	0.73	1053	0.80	1083	0.88	1113	0.96
3200	901	0.42	941	0.50	952	0.52	1001	0.63	1037	0.72	1065	0.79	1098	0.88	1133	0.98	1163	1.07	1192	1.16
3600	1005	0.57	1040	0.66	1065	0.72	1072	0.74	1124	0.89	1158	1.00	1184	1.08	1209	1.17	1240	1.27	1272	1.39
4000	1108	0.77	1141	0.86	1173	0.96	1185	1.00	1191	1.01	1242	1.19	1276	1.33	1300	1.42	1323	1.52	1346	1.61
4400	1213	1.00	1243	1.10	1272	1.21	1298	1.31	1305	1.33	1310	1.35	1356	1.53	1391	1.70	1416	1.83	1437	1.93
4800	1317	1.28	1346	1.39	1372	1.50	1399	1.62	1418	1.71	1424	1.73	1429	1.75	1464	1.91	1502	2.12	1530	2.28
CFM	External Static Pressure (Inches of Water Gauge)																			
	1.10"		1.20"		1.30"		1.40"		1.50"		1.60"		1.70"		1.80"		1.90"		2.00"	
	RPM	BHP	RPM	BHP	RPM	BHP	RPM	BHP	RPM	BHP	RPM	BHP	RPM	BHP	RPM	BHP	RPM	BHP	RPM	BHP
2000*	1001	0.72	1030	0.78	1059	0.85	1086	0.92	1113	0.99	1139	1.07	1165	1.14	1189	1.21	1212	1.29	1235	1.37
2400*	1070	0.87	1099	0.94	1127	1.02	1153	1.09	1180	1.17	1206	1.25	1230	1.33	1254	1.41	1277	1.49	1300	1.58
2800*	1142	1.05	1170	1.13	1197	1.21	1224	1.29	1249	1.38	1274	1.47	1298	1.55	1322	1.64	1345	1.73	1367	1.82
3200	1218	1.25	1244	1.34	1271	1.44	1295	1.52	1321	1.62	1345	1.71	1368	1.80	1392	1.90	1414	2.00	1437	2.10
3600	1299	1.49	1325	1.59	1348	1.69	1372	1.79	1396	1.89	1419	1.99	1441	2.10	1464	2.20	1486	2.30	1508	2.42
4000	1374	1.73	1403	1.86	1430	1.98	1453	2.09	1476	2.20	1497	2.31	1519	2.42	1540	2.53	1561	2.65	1582	2.77
4400	1458	2.03	1478	2.14	1504	2.27	1530	2.40	1556	2.54	1579	2.67	1600	2.79	1620	2.91	-	-	-	-
4800	1550	2.40	1570	2.51	1589	2.63	1607	2.74	1629	2.87	-	-	-	-	-	-	-	-	-	-

**Notes:**

1. For direct drive evaporator fan speed (rpm), refer to the applicable table in the fan performance section.
2. Data includes pressure drop due to standard filters and wet coils.
3. To determine static pressure drop due to other options/accessories, refer to the applicable table in the fan performance section.
4. Direct drive fan motor heat (MBh) = 2.7912 x fan bhp + 0.1388
5. Factory supplied motors, in commercial equipment, are definite purpose motors, specifically designed and tested to operate reliably and continuously at all cataloged conditions. Using the full horsepower range of our fan motors as shown in our tabular data will not result in nuisance tripping or premature motor failure. Our product's warranty will not be affected.
6. \* For 2000, 2400, and 2800 cfm, unit application below 320 cfm/ton are only applicable on T\_C models only (no gas heat). See below for restrictions.
7. \* For electric heat applications, minimum airflow is set to 320 cfm/ton, unless specified otherwise, values found in electric heat temperature rise table.
8. \*Dehumidification (hot gas reheat) or TXV with Froststat™ and crankcase heaters are required on applications below 320 cfm/ton.

## Evaporator Fan Performance – High Efficiency

**Table 136. Direct drive evaporator fan performance – 10 tons high efficiency – THC120F3,F4 horizontal airflow**

CFM	External Static Pressure (Inches of Water Gauge)																			
	0.10"		0.20"		0.30"		0.40"		0.50"		0.60"		0.70"		0.80"		0.90"		1.00"	
	RPM	BHP	RPM	BHP	RPM	BHP	RPM	BHP	RPM	BHP	RPM	BHP	RPM	BHP	RPM	BHP	RPM	BHP	RPM	BHP
2000*	573	0.11	626	0.16	680	0.21	727	0.26	770	0.32	815	0.38	857	0.44	896	0.51	933	0.58	968	0.65
2400*	666	0.17	712	0.22	756	0.28	802	0.34	844	0.41	881	0.47	917	0.53	955	0.61	991	0.68	1025	0.76
2800*	762	0.25	803	0.31	841	0.37	879	0.43	919	0.51	956	0.58	991	0.66	1022	0.73	1052	0.81	1085	0.89
3200	857	0.35	897	0.42	931	0.49	964	0.56	997	0.63	1032	0.72	1065	0.80	1099	0.89	1128	0.97	1156	1.05
3600	954	0.47	991	0.56	1023	0.63	1054	0.71	1082	0.79	1111	0.87	1142	0.96	1172	1.06	1202	1.16	1232	1.25
4000	1051	0.63	1086	0.72	1117	0.81	1145	0.89	1172	0.98	1198	1.06	1225	1.16	1251	1.25	1278	1.36	1306	1.46
4400	1149	0.81	1182	0.92	1212	1.02	1239	1.11	1264	1.21	1288	1.30	1311	1.39	1335	1.49	1360	1.59	1384	1.70
4800	1247	1.04	1279	1.15	1307	1.26	1333	1.36	1357	1.47	1380	1.57	1402	1.67	1424	1.77	1446	1.88	1467	1.98
CFM	External Static Pressure (Inches of Water Gauge)																			
	1.10"		1.20"		1.30"		1.40"		1.50"		1.60"		1.70"		1.80"		1.90"		2.00"	
	RPM	BHP	RPM	BHP	RPM	BHP	RPM	BHP	RPM	BHP	RPM	BHP	RPM	BHP	RPM	BHP	RPM	BHP	RPM	BHP
2000*	1001	0.72	1033	0.79	1064	0.87	1094	0.94	1123	1.02	1150	1.10	1178	1.18	1204	1.27	1230	1.35	1255	1.44
2400*	1058	0.84	1090	0.92	1120	1.00	1150	1.08	1179	1.17	1206	1.25	1233	1.34	1259	1.43	1284	1.52	1309	1.62
2800*	1118	0.98	1149	1.06	1178	1.15	1208	1.24	1236	1.33	1263	1.42	1290	1.52	1315	1.62	1340	1.71	1365	1.81
3200	1182	1.14	1209	1.22	1238	1.32	1267	1.42	1294	1.51	1321	1.61	1347	1.71	1374	1.82	1398	1.92	1422	2.03
3600	1259	1.34	1285	1.44	1309	1.53	1332	1.63	1356	1.73	1383	1.83	1408	1.94	1433	2.05	1457	2.16	1481	2.28
4000	1333	1.58	1360	1.68	1385	1.78	1409	1.88	1432	1.99	1453	2.09	1475	2.20	1495	2.31	1518	2.42	1541	2.54
4400	1410	1.82	1434	1.94	1459	2.06	1483	2.18	1507	2.29	1530	2.41	1552	2.52	1572	2.63	1592	2.75	1611	2.86
4800	1490	2.10	1512	2.22	1535	2.35	1558	2.48	1581	2.61	1603	2.74	1626	2.87	-	-	-	-	-	-

**Notes:**

1. For direct drive evaporator fan speed (rpm), refer to the applicable table in the fan performance section.
2. Data includes pressure drop due to standard filters and wet coils.
3. To determine static pressure drop due to other options/accessories, refer to the applicable table in the fan performance section.
4. Direct drive fan motor heat (MBh) = 2.7912 x fan bhp + 0.1388
5. Factory supplied motors, in commercial equipment, are definite purpose motors, specifically designed and tested to operate reliably and continuously at all cataloged conditions. Using the full horsepower range of our fan motors as shown in our tabular data will not result in nuisance tripping or premature motor failure. Our product's warranty will not be affected.
6. \* For 2000, 2400, and 2800 cfm, unit application below 320 cfm/ton are only applicable on T\_C models only (no gas heat). See below for restrictions.
7. \* For electric heat applications, minimum airflow is set to 320 cfm/ton, unless specified otherwise, values found in electric heat temperature rise table.
8. \*Dehumidification (hot gas reheat) or TXV with Froststat™ and crankcase heaters are required on applications below 320 cfm/ton.



## Evaporator Fan Performance – High Efficiency

**Table 137. Direct drive evaporator fan performance – 10 tons high efficiency – YHC120F3,F4,FW low & medium gas heat, downflow airflow**

External Static Pressure (Inches of Water Gauge)																						
		0.10"		0.20"		0.30"		0.40"		0.50"		0.60"		0.70"		0.80"		0.90"		1.00"		
CFM	RPM	BHP	RPM	BHP	RPM	BHP	RPM	BHP	RPM	BHP	RPM	BHP	RPM	BHP	RPM	BHP	RPM	BHP	RPM	BHP	RPM	BHP
3200	905	0.22	944	0.28	980	0.33	1015	0.39	1047	0.43	1077	0.47	1106	0.51	1135	0.56	1162	0.60	1187	0.65		
3600	1008	0.30	1044	0.36	1077	0.43	1109	0.49	1140	0.55	1168	0.59	1196	0.64	1222	0.69	1249	0.74	1273	0.79		
4000	1112	0.40	1145	0.47	1176	0.54	1205	0.60	1234	0.67	1261	0.74	1288	0.79	1313	0.85	1338	0.90	1362	0.95		
4400	1217	0.52	1247	0.59	1276	0.67	1304	0.74	1330	0.82	1356	0.89	1381	0.97	1406	1.03	1429	1.09	1451	1.14		
4800	1322	0.66	1350	0.74	1377	0.82	1403	0.90	1428	0.98	1452	1.07	1476	1.15	1499	1.23	1522	1.31	1543	1.37		
External Static Pressure (Inches of Water Gauge)																						
		1.10"		1.20"		1.30"		1.40"		1.50"		1.60"		1.70"		1.80"		1.90"		2.00"		
CFM	RPM	BHP	RPM	BHP	RPM	BHP	RPM	BHP	RPM	BHP	RPM	BHP	RPM	BHP	RPM	BHP	RPM	BHP	RPM	BHP	RPM	BHP
3200	1213	0.69	1236	0.74	1260	0.78	1283	0.83	1306	0.88	1328	0.93	1348	0.97	1369	1.02	1389	1.07	1409	1.12		
3600	1297	0.84	1321	0.89	1343	0.94	1365	0.99	1387	1.04	1409	1.09	1429	1.14	1449	1.20	1469	1.25	1488	1.30		
4000	1385	1.01	1407	1.06	1429	1.12	1450	1.17	1471	1.23	1491	1.28	1512	1.34	1531	1.39	1550	1.45	1570	1.51		
4400	1474	1.20	1495	1.26	1516	1.32	1537	1.38	1557	1.44	1577	1.50	1596	1.56	1615	1.62	1634	1.68	1653	1.75		
4800	1564	1.43	1586	1.49	1606	1.56	1626	1.62	1645	1.68	1665	1.75	1683	1.81	1702	1.88	1720	1.95	1738	2.01		

**Notes:**

1. For direct drive evaporator fan speed (rpm), refer to the applicable table in the fan performance section.
2. Data includes pressure drop due to standard filters and wet coils.
3. To determine static pressure drop due to other options/accessories, refer to the applicable table in the fan performance section.
4. Direct drive fan motor heat (MBh) = 2.7912 x fan bhp + 0.1388
5. Factory supplied motors, in commercial equipment, are definite purpose motors, specifically designed and tested to operate reliably and continuously at all cataloged conditions. Using the full horsepower range of our fan motors as shown in our tabular data will not result in nuisance tripping or premature motor failure. Our product's warranty will not be affected.



## Evaporator Fan Performance – High Efficiency

**Table 138. Direct drive evaporator fan performance – 10 tons high efficiency – YHC120F3,F4,FW low & medium gas heat, horizontal airflow**

External Static Pressure (Inches of Water Gauge)																						
		0.10"		0.20"		0.30"		0.40"		0.50"		0.60"		0.70"		0.80"		0.90"		1.00"		
CFM	RPM	BHP	RPM	BHP	RPM	BHP	RPM	BHP	RPM	BHP	RPM	BHP	RPM	BHP	RPM	BHP	RPM	BHP	RPM	BHP	RPM	BHP
3200	853	0.34	896	0.42	935	0.50	970	0.57	1004	0.65	1037	0.73	1070	0.81	1101	0.90	1130	0.98	1160	1.07		
3600	950	0.47	988	0.55	1025	0.64	1058	0.72	1089	0.81	1120	0.89	1149	0.98	1180	1.08	1209	1.17	1235	1.26		
4000	1049	0.63	1081	0.71	1116	0.81	1148	0.91	1177	1.00	1206	1.09	1233	1.19	1260	1.28	1286	1.38	1314	1.49		
4400	1148	0.81	1176	0.90	1208	1.01	1239	1.12	1267	1.22	1294	1.33	1320	1.42	1344	1.53	1369	1.63	1394	1.74		
4800	1247	1.04	1273	1.14	1301	1.24	1330	1.36	1357	1.48	1384	1.59	1408	1.70	1432	1.81	1455	1.92	1478	2.04		
External Static Pressure (Inches of Water Gauge)																						
		1.10"		1.20"		1.30"		1.40"		1.50"		1.60"		1.70"		1.80"		1.90"		2.00"		
CFM	RPM	BHP	RPM	BHP	RPM	BHP	RPM	BHP	RPM	BHP	RPM	BHP	RPM	BHP	RPM	BHP	RPM	BHP	RPM	BHP	RPM	BHP
3200	1191	1.16	1221	1.25	1248	1.35	1275	1.44	1300	1.53	1325	1.62	1349	1.72	1373	1.81	1396	1.91	1418	2.01		
3600	1261	1.36	1287	1.45	1315	1.55	1342	1.66	1367	1.76	1394	1.87	1417	1.97	1441	2.08	1463	2.18	1484	2.28		
4000	1339	1.60	1364	1.70	1388	1.80	1411	1.90	1435	2.01	1460	2.12	1484	2.24	1508	2.36	1530	2.47	1553	2.59		
4400	1419	1.86	1443	1.98	1466	2.09	1489	2.20	1510	2.31	1532	2.43	1553	2.54	1575	2.65	1597	2.78	1619	2.90		
4800	1500	2.16	1523	2.28	1546	2.40	1567	2.52	1589	2.65	1611	2.78	1631	2.90	-	-	-	-	-	-		

**Notes:**

1. For direct drive evaporator fan speed (rpm), refer to the applicable table in the fan performance section.
2. Data includes pressure drop due to standard filters and wet coils.
3. To determine static pressure drop due to other options/accessories, refer to the applicable table in the fan performance section.
4. Direct drive fan motor heat (MBh) = 2.7912 x fan bhp + 0.1388
5. Factory supplied motors, in commercial equipment, are definite purpose motors, specifically designed and tested to operate reliably and continuously at all cataloged conditions. Using the full horsepower range of our fan motors as shown in our tabular data will not result in nuisance tripping or premature motor failure. Our product's warranty will not be affected.



## Evaporator Fan Performance – High Efficiency

**Table 139. Direct drive evaporator fan performance – 10 tons high efficiency – YHC120F3,F4,FW high gas heat, downflow airflow**

External Static Pressure (Inches of Water Gauge)																						
		0.10"		0.20"		0.30"		0.40"		0.50"		0.60"		0.70"		0.80"		0.90"		1.00"		
CFM	RPM	BHP	RPM	BHP	RPM	BHP	RPM	BHP	RPM	BHP	RPM	BHP	RPM	BHP	RPM	BHP	RPM	BHP	RPM	BHP	RPM	BHP
3200	900	0.42	939	0.50	972	0.57	1004	0.64	1037	0.72	1069	0.80	1099	0.88	1127	0.95	1155	1.03	1184	1.12		
3600	1005	0.58	1037	0.66	1071	0.74	1099	0.82	1128	0.90	1157	0.99	1186	1.08	1214	1.17	1240	1.26	1265	1.35		
4000	1110	0.77	1138	0.86	1170	0.96	1198	1.05	1223	1.13	1249	1.22	1275	1.32	1302	1.42	1327	1.52	1352	1.62		
4400	1215	1.01	1241	1.10	1268	1.20	1297	1.31	1321	1.41	1344	1.50	1367	1.60	1391	1.71	1415	1.82	1439	1.93		
4800	1321	1.29	1345	1.39	1369	1.49	1395	1.61	1420	1.73	1442	1.83	1463	1.94	1484	2.04	1506	2.16	1529	2.28		
External Static Pressure (Inches of Water Gauge)																						
		1.10"		1.20"		1.30"		1.40"		1.50"		1.60"		1.70"		1.80"		1.90"		2.00"		
CFM	RPM	BHP	RPM	BHP	RPM	BHP	RPM	BHP	RPM	BHP	RPM	BHP	RPM	BHP	RPM	BHP	RPM	BHP	RPM	BHP	RPM	BHP
3200	1212	1.21	1239	1.29	1266	1.38	1291	1.47	1316	1.56	1342	1.65	1367	1.75	1392	1.84	1415	1.94	1438	2.03		
3600	1290	1.44	1316	1.53	1341	1.63	1365	1.72	1390	1.82	1414	1.92	1436	2.02	1459	2.12	1482	2.22	1506	2.33		
4000	1375	1.72	1398	1.81	1420	1.91	1443	2.01	1466	2.12	1488	2.23	1511	2.33	1534	2.45	1554	2.55	1575	2.66		
4400	1462	2.03	1485	2.15	1506	2.25	1527	2.36	1548	2.47	1567	2.57	1588	2.69	1609	2.80	1631	2.93	-	-		
4800	1550	2.39	1572	2.51	1593	2.63	1614	2.75	1634	2.87	-	-	-	-	-	-	-	-	-	-		

**Notes:**

1. For direct drive evaporator fan speed (rpm), refer to the applicable table in the fan performance section.
2. Data includes pressure drop due to standard filters and wet coils.
3. To determine static pressure drop due to other options/accessories, refer to the applicable table in the fan performance section.
4. Direct drive fan motor heat (MBh) = 2.7912 x fan bhp + 0.1388
5. Factory supplied motors, in commercial equipment, are definite purpose motors, specifically designed and tested to operate reliably and continuously at all cataloged conditions. Using the full horsepower range of our fan motors as shown in our tabular data will not result in nuisance tripping or premature motor failure. Our product's warranty will not be affected.

## Evaporator Fan Performance – High Efficiency

**Table 140. Direct drive evaporator fan performance – 10 tons high efficiency – YHC120F3,F4,FW high gas heat, horizontal airflow**

External Static Pressure (Inches of Water Gauge)																						
		0.10"		0.20"		0.30"		0.40"		0.50"		0.60"		0.70"		0.80"		0.90"		1.00"		
CFM	RPM	BHP	RPM	BHP	RPM	BHP	RPM	BHP	RPM	BHP	RPM	BHP	RPM	BHP	RPM	BHP	RPM	BHP	RPM	BHP	RPM	BHP
3200	868	0.37	906	0.44	943	0.51	980	0.59	1014	0.67	1046	0.74	1078	0.82	1109	0.91	1139	0.99	1168	1.08		
3600	969	0.50	1001	0.58	1035	0.66	1068	0.74	1100	0.83	1131	0.92	1160	1.01	1189	1.10	1217	1.19	1244	1.28		
4000	1070	0.67	1098	0.75	1129	0.84	1159	0.93	1188	1.02	1218	1.12	1245	1.22	1272	1.32	1298	1.41	1324	1.52		
4400	1172	0.87	1197	0.96	1224	1.06	1251	1.16	1279	1.26	1306	1.36	1332	1.46	1358	1.57	1383	1.68	1407	1.79		
4800	1274	1.12	1297	1.21	1321	1.31	1346	1.42	1371	1.53	1396	1.64	1421	1.75	1445	1.86	1469	1.98	1493	2.10		
External Static Pressure (Inches of Water Gauge)																						
		1.10"		1.20"		1.30"		1.40"		1.50"		1.60"		1.70"		1.80"		1.90"		2.00"		
CFM	RPM	BHP	RPM	BHP	RPM	BHP	RPM	BHP	RPM	BHP	RPM	BHP	RPM	BHP	RPM	BHP	RPM	BHP	RPM	BHP	RPM	BHP
3200	1196	1.16	1225	1.25	1254	1.34	1280	1.43	1306	1.52	1330	1.61	1355	1.71	1378	1.80	1400	1.89	1424	1.99		
3600	1271	1.37	1297	1.47	1323	1.57	1347	1.66	1374	1.77	1398	1.86	1423	1.97	1447	2.07	1470	2.17	1492	2.27		
4000	1349	1.62	1375	1.72	1399	1.83	1422	1.93	1445	2.03	1468	2.14	1491	2.25	1514	2.36	1538	2.48	1561	2.59		
4400	1431	1.90	1455	2.01	1478	2.12	1499	2.23	1523	2.35	1544	2.46	1565	2.57	1587	2.69	1608	2.81	1629	2.92		
4800	1515	2.21	1537	2.33	1559	2.45	1581	2.57	1602	2.69	1623	2.82	1643	2.94	-	-	-	-	-	-		

**Notes:**

1. For direct drive evaporator fan speed (rpm), refer to the applicable table in the fan performance section.
2. Data includes pressure drop due to standard filters and wet coils.
3. To determine static pressure drop due to other options/accessories, refer to the applicable table in the fan performance section.
4. Direct drive fan motor heat (MBh) = 2.7912 x fan bhp + 0.1388
5. Factory supplied motors, in commercial equipment, are definite purpose motors, specifically designed and tested to operate reliably and continuously at all cataloged conditions. Using the full horsepower range of our fan motors as shown in our tabular data will not result in nuisance tripping or premature motor failure. Our product's warranty will not be affected.



# Fan Performance

**Table 141. Standard motor & sheave/fan speed (rpm)**

Tons	Unit Model Number	Fan Sheave	6 Turns Open	5 Turns Open	4 Turns Open	3 Turns Open	2 Turns Open	1 Turns Open	Closed
6	T/YSC072H	AK64x1"	N/A	723	779	835	890	946	1002
7.5	T/YSC090H	AK59x1"	N/A	805	865	925	985	1045	1105
7.5	T/YSC092H	AK59x1"	N/A	639	696	753	810	867	924
8.5	T/YSC102H	AK64x1"	N/A	767	807	847	888	928	1036
3	T/YHC036E	AK51x3/4"	N/A	765	835	905	975	1045	1115
4	T/YHC048E	AK54x3/4"	N/A	729	794	860	926	911	1057
4	T/YHC048F	AK54x3/4"	N/A	729	794	860	926	911	1057
5	T/YHC060E	AK49x3/4"	N/A	801	871	942	1012	1083	1154
5	T/YHC060F	AK49x3/4"	N/A	801	871	942	1012	1083	1154
6	T/YHC072*	AK64x1"	N/A	728	784	840	896	952	1008

**Note:** Factory set at 3 turns open.

**Table 142. Standard motor & low static drive accessory sheave/fan speed (rpm)**

Tons	Unit Model Number	Fan Sheave	6 Turns Open	5 Turns Open	4 Turns Open	3 Turns Open	2 Turns Open	1 Turns Open	Closed
7.5	T/YSC090H	AK74x1"	N/A	602	650	698	746	794	842
7.5	T/YSC092H	AK99x1"	N/A	462	498	533	569	604	640
7.5	T/YSC092H	AK79x1"	N/A	614	657	700	743	786	829
8.5	T/YSC102H	AK99x1"	N/A	512	548	583	619	654	690
8.5	T/YSC102H	AK79x1"	N/A	631	676	721	766	811	856
3	YHC036E	AK71x3/4"	N/A	556	607	657	707	758	808
3	THC036E	AK99x3/4"	N/A	385	424	462	501	539	578
4	YHC048E,F	AK71x3/4"	N/A	556	607	657	707	758	808
4	THC048E,F	AK99x3/4"	N/A	385	424	462	501	539	578
5	YHC060E,F	AK71x3/4"	N/A	556	607	657	707	758	808
5	THC060E,F	AK99x3/4"	N/A	385	424	462	501	539	578
6	YHC072E,F	AK79x1"	N/A	581	626	671	716	761	805
6	THC072E,F	AK99x1"	N/A	462	497	533	569	604	640

**Note:** Factory set at 3 turns open.

**Table 143. Standard motor & high static drive accessory sheave/fan speed (rpm)**

Tons	Unit Model Number	Fan Sheave	6 Turns Open	5 Turns Open	4 Turns Open	3 Turns Open	2 Turns Open	1 Turns Open	Closed
6	T/YSC072H	AK56x1"	N/A	831	895	959	1022	1086	1150
3	T/YHC036E	AK41x3/4"	N/A	N/A	967	1040	1113	1187	N/A
4	T/YHC048E,F	AK41x3/4"	N/A	N/A	966	1048	1132	1215	N/A
5	T/YHC060E,F	AK41x3/4"	N/A	N/A	961	1041	1122	1203	N/A

**Note:** Factory set at 3 turns open.

**Table 144. Oversized motor & drive sheave/fan speed (rpm)**

Tons	Unit Model Number	Fan Sheave	6 Turns Open	5 Turns Open	4 Turns Open	3 Turns Open	2 Turns Open	1 Turns Open	Closed
6	T/YSC072H	AK56x1"	N/A	958	1022	1086	1150	1214	1278
7.5	T/YSC090H	AK56x1"	N/A	958	1022	1086	1150	1214	1278
7.5	T/YSC092H	AK64x1"	N/A	860	910	960	1010	1060	1110
8.5	T/YSC102H	AK56x1"	N/A	998	1050	1103	1155	1207	1260
6	T/YHC072E,F	AK56x1"	N/A	885	948	1010	1073	1135	1198

**Note:** Factory set at 3 turns open.

**Table 145. Oversized motor & high static drive sheave/fan speed (rpm)**

Tons	Unit Model Number	Fan Sheave	5 Turns Open	4 Turns Open	3 Turns Open	2 Turns Open	1 Turns Open	Closed
6	T/YSC072H	AK54x1"	N/A	995	1061	1128	1194	1261
7.5	T/YSC090H	BK52x1"	N/A	1127	1197	1268	1338	1409
7.5	T/YSC092H	AK56x1"	986	1043	1099	1156	1212	1269

**Note:** Factory set at 3 turns open.

**Table 146. Direct drive plenum fan settings (rpm vs. voltage) – T/YHC074F, T/YHC092F, T/YHC102F, T/YSC120H, T/YHC120F, T/YSC092H (Digit 15=6,7), T/YSC102H (Digit 15=6,7)**

Potentiometer Voltage	Motor RPM
1	N/A
1.25	N/A
1.5	N/A
1.75	N/A
2	N/A
2.25	325
2.5	402
2.75	465
3	544
3.25	630
3.5	716
3.75	775
4	845
4.25	912
4.5	976
4.75	1044
5	1115
5.25	1203
5.5	1253
5.75	1312
6	1368
6.25	1425
6.5	1475
6.75	1533
7	1581
7.25	1615
7.5	1615

**Notes:**

1. See fan tables for unit rpm and cfm units.
2. Factory setting is 5V.

**Table 147. Outdoor sound power level - dB (ref. 10 - 12 W)**

Tons	Unit Model Number	Octave Center Frequency								Overall dBA
		63	125	250	500	1000	2000	4000	8000	
3	T/YSC036G	85	86	79	76	73	69	65	63	79
4	T/YSC048G <sup>(a)</sup>	90	82	79	76	75	70	66	64	80
5	T/YSC060G	84	80	80	79	77	72	67	65	81
6	T/YSC072H	91	95	90	87	84	79	75	68	89
7.5	T/YSC090H	87	87	86	86	83	79	75	69	88
7.5	T/YSC092H	92	96	92	89	85	80	76	69	91
8.5	T/YSC102H	86	84	84	85	82	77	73	67	86
10	T/YSC120H	91	86	90	86	82	78	73	67	88
3	T/YHC036E	79	85	79	79	77	71	67	58	81
4	T/YHC048E	80	86	84	85	83	79	73	67	87
4	T/YHC048F	80	86	84	85	83	79	73	67	87
5	T/YHC060E	80	86	84	85	83	79	73	67	87
5	T/YHC060F	80	86	84	85	83	79	73	67	87



## Fan Performance

**Table 147. Outdoor sound power level - dB (ref. 10 - 12 W) (continued)**

Tons	Unit Model Number	Octave Center Frequency								Overall dBA
		63	125	250	500	1000	2000	4000	8000	
6	T/YHC072E,F	91	95	90	87	84	79	75	68	89
6	T/YHC074F	91	95	90	87	84	79	75	68	89
7.5	T/YHC092F	91	86	90	86	82	78	73	67	88
8.5	T/YHC102F	83	85	85	86	84	78	74	70	88
10	T/YHC120F	89	87	91	85	80	77	73	66	87

**Note:** Tests follow ARI270-95.

(a) T/YSC063G models have same sound ratings as T/YSC0(43,48)G.

**Table 148. Static pressure drop through accessories (inches water column) – standard efficiency – 3 to 10 tons**

Tons	Unit Model Number	cfm	Standard Filters <sup>(a)</sup>	2" MERV 8 Filter	2" MERV 13 Filter	Economizer with OA/RA Dampers <sup>(b)</sup>						Electric Heater Accessory (kW) <sup>(c)</sup>				
						Downflow		Low Leak <sup>(d)</sup>		Horizontal		5-6	9-18	23-36	54	
						100% OA	100% RA	100% OA	100% RA	100% OA	100% RA					
3	T/YSC036G	960	0.01	0.03	0.04	0.04	0.01	0.09	0.03	0.04	0.01	0.01	0.01	0.01	0.01	—
3	T/YSC036G	1200	0.02	0.04	0.05	0.06	0.01	0.13	0.05	0.06	0.01	0.02	0.02	0.02	0.02	—
3	T/YSC036G	1440	0.03	0.05	0.06	0.08	0.02	0.19	0.07	0.08	0.01	0.02	0.03	0.03	0.03	—
4	T/YSC048G	1280	0.03	0.05	0.06	0.09	0.02	0.15	0.05	0.09	0.01	0.02	0.03	0.03	0.03	—
4	T/YSC048G	1600	0.04	0.07	0.07	0.13	0.04	0.24	0.08	0.13	0.02	0.04	0.05	0.05	0.05	—
4	T/YSC048G	1920	0.06	0.10	0.08	0.17	0.06	0.34	0.11	0.17	0.02	0.05	0.06	0.06	0.08	—
5	T/YSC060G	1600	0.04	0.07	0.07	0.13	0.04	0.24	0.08	0.13	0.02	0.04	0.05	0.05	0.05	—
5	T/YSC060G	2000	0.06	0.10	0.09	0.18	0.07	0.37	0.12	0.18	0.02	0.06	0.07	0.07	0.08	—
5	T/YSC060G	2400	0.08	0.13	0.10	0.25	0.11	0.53	0.16	0.25	0.03	0.08	0.10	0.12	0.12	—
6	T/YSC072H	1920	0.04	0.07	0.10	0.10	0.01	0.15	0.08	0.06	0.02	—	0.01	0.02	—	—
6	T/YSC072H	2400	0.06	0.09	0.13	0.11	0.02	0.23	0.12	0.08	0.02	—	0.02	0.03	—	—
6	T/YSC072H	2880	0.09	0.12	0.15	0.13	0.04	0.34	0.18	0.10	0.04	—	0.03	0.05	—	—
7.5	T/YSC090H	2400	0.04	0.06	0.12	0.11	0.02	0.23	0.12	0.08	0.02	—	0.02	0.02	—	—
7.5	T/YSC090H	3000	0.06	0.09	0.13	0.14	0.05	0.37	0.19	0.12	0.05	—	0.03	0.03	—	—
7.5	T/YSC090H	3600	0.09	0.13	0.15	0.21	0.07	0.54	0.27	0.25	0.08	—	0.04	0.05	—	—
7.5	T/YSC092H	2400	0.04	0.06	0.12	0.11	0.02	0.23	0.12	0.08	0.02	—	0.02	0.02	—	—
7.5	T/YSC092H	3000	0.06	0.09	0.13	0.14	0.05	0.37	0.19	0.12	0.05	—	0.03	0.03	—	—
7.5	T/YSC092H	3600	0.09	0.13	0.15	0.21	0.07	0.54	0.27	0.25	0.08	—	0.04	0.05	—	—
8.5	T/YSC102H	2720	0.05	0.08	0.13	0.12	0.03	0.30	0.16	0.09	0.04	—	0.02	0.03	—	—
8.5	T/YSC102H	3400	0.08	0.11	0.14	0.19	0.06	0.48	0.24	0.18	0.06	—	0.03	0.04	—	—
8.5	T/YSC102H	4080	0.12	0.16	0.16	0.30	0.07	0.71	0.35	0.31	0.09	—	0.05	0.06	—	—
10	T/YSC120H	3200	0.07	0.10	0.14	0.17	0.05	0.42	0.22	0.14	0.05	—	0.02	0.03	0.05	—
10	T/YSC120H	4000	0.11	0.15	0.16	0.26	0.07	0.68	0.34	0.30	0.08	—	0.02	0.03	0.05	—
10	T/YSC120H	4800	0.16	0.20	0.18	0.34	0.09	0.99	0.48	0.35	0.10	—	0.03	0.04	0.06	—

**Note:** Tests follow ARI1270-95.

(a) Tested with standard filters. Difference in pressure drop should be considered when utilizing optional 2" MERV 8 and MERV 13 filters.

(b) OA = Outside Air and RA = Return Air.

(c) Nominal kW ratings at 240, 480, 600 volts. Heaters only available on T units. Electric heaters restricted on applications below 320 cfm/ton.

(d) Low leak - downflow only.



Fan Performance

Table 149. Static pressure drop through accessories (inches water column) – high efficiency – 3 to 10 tons

Tons	Unit Model Number	cfm	Standard Filters <sup>(a)</sup>	2" MERV 8 Filter	2" MERV 13 Filter	Reheat Coil	Economizer with OA/RA Dampers <sup>(b)</sup>						Electric Heater Accessory (kW) <sup>(c)</sup>			
							Downflow		Low Leak <sup>(d)</sup>		Horizontal		5-6	9-18	23-36	54
							100% OA	100% RA	100% OA	100% RA	100% OA	100% RA	100% OA	100% RA		
3	T/YHC036E3,4,W	600	0.01	0.02	0.03	0.04	0.03	0.01	0.03	0.02	0.03	0.01	—	—	—	—
3	T/YHC036E3,4,W	960	0.01	0.03	0.04	0.08	0.04	0.01	0.09	0.03	0.04	0.01	0.01	0.01	0.01	—
3	T/YHC036E3,4,W	1200	0.02	0.04	0.05	0.10	0.06	0.01	0.13	0.05	0.06	0.01	0.02	0.02	0.02	—
3	T/YHC036E3,4,W	1440	0.03	0.05	0.06	0.14	0.08	0.02	0.19	0.07	0.08	0.01	0.02	0.03	0.03	—
4	T/YHC048E/F3,4,W	800	0.01	0.03	0.04	0.03	0.06	0.00	0.03	0.03	0.03	0.01	—	—	—	—
4	T/YHC048E/F3,4,W	1280	0.02	0.04	0.03	0.07	0.08	0.00	0.07	0.03	0.04	0.01	0.01	0.00	0.01	—
4	T/YHC048E/F3,4,W	1600	0.03	0.06	0.05	0.09	0.09	0.01	0.10	0.05	0.05	0.02	0.02	0.01	0.02	—
4	T/YHC048E/F3,4,W	1920	0.05	0.08	0.07	0.12	0.10	0.01	0.15	0.08	0.07	0.02	0.02	0.01	0.03	—
5	T/YHC060E/F3,4,W	1000	0.01	0.04	0.03	0.05	0.06	0.01	0.04	0.02	0.06	0.01	—	—	—	—
5	T/YHC060E/F3,4,W	1600	0.03	0.06	0.08	0.09	0.09	0.01	0.10	0.05	0.05	0.01	0.02	0.01	0.02	—
5	T/YHC060E/F3,4,W	2000	0.05	0.08	0.11	0.13	0.11	0.01	0.16	0.08	0.07	0.02	0.02	0.02	0.03	—
5	T/YHC060E/F3,4,W	2400	0.07	0.10	0.13	0.17	0.12	0.03	0.23	0.12	0.09	0.04	0.03	0.02	0.04	—
6	T/YHC072E/F	1920	0.04	0.07	0.10	0.03	0.10	0.01	0.15	0.08	0.06	0.02	—	0.01	0.02	—
6	T/YHC072E/F	2400	0.06	0.09	0.13	0.07	0.11	0.02	0.23	0.12	0.08	0.02	—	0.02	0.03	—
6	T/YHC072E/F	2880	0.09	0.12	0.15	0.12	0.13	0.04	0.34	0.18	0.10	0.04	—	0.03	0.05	—
6	T/YHC074F	1920	0.03	0.04	0.10	—	0.09	0.01	0.15	0.08	0.06	0.01	—	0.01	0.01	—
6	T/YHC074F	2400	0.04	0.06	0.12	—	0.11	0.02	0.23	0.12	0.08	0.02	—	0.01	0.01	—
6	T/YHC074F	2880	0.06	0.08	0.13	—	0.13	0.04	0.34	0.18	0.11	0.04	—	0.01	0.02	—
7.5	T/YHC092F	1500	0.02	0.03	0.08	0.03	0.07	0.01	0.09	0.05	0.05	0.04	—	—	—	—
7.5	T/YHC092F	2400	0.04	0.06	0.12	0.06	0.11	0.02	0.23	0.12	0.08	0.02	—	0.01	0.01	—
7.5	T/YHC092F	3000	0.06	0.09	0.13	0.08	0.14	0.05	0.37	0.19	0.12	0.05	—	0.01	0.02	—
7.5	T/YHC092F	3600	0.09	0.13	0.15	0.11	0.21	0.07	0.54	0.27	0.25	0.08	—	0.02	0.03	—
8.5	T/YHC102F	1700	0.02	0.05	0.11	0.04	0.07	0.01	0.11	0.06	0.05	0.02	—	—	—	—
8.5	T/YHC102F	2720	0.05	0.08	0.13	0.07	0.12	0.03	0.30	0.16	0.09	0.04	—	0.01	0.02	—
8.5	T/YHC102F	3400	0.08	0.11	0.14	0.10	0.19	0.06	0.48	0.24	0.18	0.06	—	0.02	0.02	—
8.5	T/YHC102F	4080	0.12	0.16	0.16	0.13	0.30	0.07	0.71	0.35	0.31	0.09	—	0.03	0.03	—
10	T/YHC120F	2000	0.03	0.06	0.11	0.05	0.08	0.03	0.16	0.08	0.07	0.02	—	—	—	—
10	T/YHC120F	3200	0.07	0.10	0.14	0.09	0.17	0.05	0.42	0.22	0.14	0.05	—	0.02	0.03	0.05
10	T/YHC120F	4000	0.11	0.15	0.16	0.12	0.26	0.07	0.68	0.34	0.30	0.08	—	0.02	0.03	0.05
10	T/YHC120F	4800	0.16	0.20	0.18	0.16	0.34	0.09	0.99	0.48	0.35	0.10	—	0.03	0.04	0.06

Note: Tests follow ARI1270-95.

- (a) Tested with standard filters. Difference in pressure drop should be considered when utilizing optional 2" MERV 8 and MERV 13 filters.
- (b) OA = Outside Air and RA = Return Air.
- (c) Nominal kW ratings at 240, 480, 600 volts. Heaters only available on T units. Electric heaters restricted on applications below 320 cfm/ton.
- (d) Low leak - downflow only.





# Heating Performance

**Table 150. Gas fired heating capacities — standard efficiency — 3 to 10 tons**

Tons	Unit Model Number	Heating Input MBh <sup>(a)</sup>	Heating Output MBh	Air Temperature Rise°F
3	YSC036G(3,4,W)*(L,X)	80/56	64.8/45.3	35-65
3	YSC036G(3,4,W)*(M,Y)	100/70	81/56.7	50-80
3	YSC036G(3,4,W)*(H,Z)	120/84	97.2/68	55-85
4	YSC048G(3,4,W)*(L,X)	80/56	64.8/45.3	20-50
4	YSC048G(3,4,W)*(M,Y)	100/70	81/56.7	30-60
4	YSC048G(3,4,W)*(H,Z)	130/91	105.3/73.7	45-75
5	YSC060G(3,4,W)*(L,X)	80/56	64.8/45.3	15-45
5	YSC060G(3,4,W)*(M,Y)	100/70	81/56.7	25-55
5	YSC060G(3,4,W)*(H,Z)	150/105	121.5/85.1	40-70
6	YSC072H(3,4,W)*(L,X)	80	64	15-45
6	YSC072H(3,4,W)*(M,Y)	120	96	20-50
6	YSC072H(3,4,W)*(H,Z)	150/105	120/84	25-55
7.5	YSC090H(3,4,W)*(L,X)	120	96	20-50
7.5	YSC090H(3,4,W)*(M,Y)	150/105	120/84	25-55
7.5	YSC090H(3,4,W)*(H,Z)	200/140	160/112	35-65
7.5	YSC092H(3,4,W)*(L,X)	120	96 <sup>(b)</sup>	15-45 <sup>(c)</sup>
7.5	YSC092H(3,4,W)*(M,Y)	150/105	120/84 <sup>(b)</sup>	20-50
7.5	YSC092H(3,4,W)*(H,Z)	200/140	160/112 <sup>(b)</sup>	35-65
8.5	YSC102H(3,4,W)*(L,X)	120	96 <sup>(b)</sup>	15-45 <sup>(c)</sup>
8.5	YSC102H(3,4,W)*(M,Y)	150/105	120/84 <sup>(b)</sup>	20-50
8.5	YSC102H(3,4,W)*(H,Z)	200/140	160/112 <sup>(b)</sup>	35-65
10	YSC120H(3,4,W)*(L,X)	150/105	120/84	20-50
10	YSC120H(3,4,W)*(M,Y)	200/140	160/112	25-55
10	YSC120H(3,4,W)*(H,Z)	235/164.5	188/131.6	25-55

**Note:** Ratings shown are for elevations up to 2,000 ft. For higher elevations, reduce ratings at a rate of 4% per 1,000 ft. elevation.

- <sup>(a)</sup> For two stage heaters (input or output), second stage is total heating capacity. Second stage/first stage.
- <sup>(b)</sup> SZVAV and Title 24 heating outputs are 81% of Heating Input.
- <sup>(c)</sup> SZVAV and Title 24 YSC092 and YSC102 low heat model air rise range is 20-50.



## Heating Performance

**Table 151. Gas fired heating capacities – high efficiency – 3 to 10 tons**

Tons	Unit Model Number	Heating Input MBh	Heating Output MBh	Air Temperature Rise°F
3	YHC036E(3,4,W)*(L,X)	60	48	25-55
3	YHC036E(3,4,W)*(M,Y)	80	64	35-65
3	YHC036E(3,4,W)*(H,Z)	120	96	55-85
4	YHC048E(3,4,W)*(L,X)	60	48	10-40
4	YHC048E(3,4,W)*(M,Y)	80	64	20-50
4	YHC048E(3,4,W)*(H,Z)	120	96	40-70
4	YHC048F(3,4,W)*(L,X)	60	48	10-40
4	YHC048F(3,4,W)*(M,Y)	80	64	20-50
4	YHC048F(3,4,W)*(H,Z)	120	96	40-70
5	YHC060E(3,4,W)*(L,X)	60	48	10-40
5	YHC060E(3,4,W)*(M,Y)	80	64	15-45
5	YHC060E(3,4,W)*(H,Z)	130	104	35-65
5	YHC060F(3,4,W)*(L,X)	60	48	10-40
5	YHC060F(3,4,W)*(M,Y)	80	64	15-45
5	YHC060F(3,4,W)*(H,Z)	130	104	35-65
6	YHC072*(3,4,W)*(L,X)	80	64	15-45
6	YHC072*(3,4,W)*(M,Y)	120	96	20-50
6	YHC072*(3,4,W)*(H,Z)	150/105	120/84	25-55
6	YHC074*(3,4)*(L,X)	80	64.8	15-45
6	YHC074*(3,4)*(M,Y)	120	97.2	20-50
6	YHC074*(3,4)*(H,Z)	150/105	121.5/85.1	25-55
7.5	YHC092F(3,4,W)*(L,X)	120	96	20-50
7.5	YHC092F(3,4,W)*(M,Y)	150/105	120/84	20-50
7.5	YHC092F(3,4,W)*(H,Z)	200/140	160/112	35-65
8.5	YHC102F(3,4,W)*(L,X)	120	96	20-50
8.5	YHC102F(3,4,W)*(M,Y)	150/105	120/84	20-50
8.5	YHC102F(3,4,W)*(H,Z)	200/140	160/112	35-65
10	YHC120F(3,4,W)*(L,X)	150/105	120/84	20-50
10	YHC120F(3,4,W)*(M,Y)	200/140	160/112	25-55
10	YHC120F(3,4,W)*(H,Z)	250/175	200/140	35-65

**Note:** Ratings shown are for elevations up to 2,000 ft. For higher elevations, reduce ratings at a rate of 4% per 1,000 ft. elevation.

**Table 152. Auxiliary electric heat capacity – 3 to 10 tons**

Tons	Unit Model Number	Total <sup>(a)</sup>		No. of Stages	Stage 1		Stage 2	
		kw Input <sup>(b)</sup>	MBh Output		kw Input	MBh Output	kw Input	MBh Output
3	T*C036*3,*4,*W	6	20.48	1	6	20.48	—	—
3	T*C036*3,*4,*W	12	40.97	2	6	20.48	6	20.48
3	T*C036*3,*4,*W	17.4	59.4	2	8.7	29.7	8.7	29.7
4	T*C048*3,*4,*W	6	20.48	1	6	20.48	—	—
4	T*C048*3,*4,*W	12	40.97	2	6	20.48	6	20.48
4	T*C048*3,*4,*W	17.4	59.4	2	8.7	29.7	8.7	29.7
5	T*C060*3,*4,*W	6	20.48	1	6	20.48	—	—
5	T*C060*3,*4,*W	12	40.97	2	6	20.48	6	20.48
5	T*C060*3,*4,*W	17.4	59.4	2	8.7	29.7	8.7	29.7
5	T*C060*3,*4,*W	23	78.52	2	8.7	29.7	14.3	48.82
6	TSC072*3,4,W	9	30.73	1	9	30.73	—	—
6	TSC072*3,4,W	18	61.45	1	18	61.45	—	—
6	TSC072*3,4,W	27	92.18	2	18	61.45	9	30.73
6	TSC072*3,4,W	36	122.9	2	18	61.45	18	61.45
6	THC072*3,4,W	9	30.73	1	9	30.73	—	—
6	THC072*3,4,W	18	61.45	1	18	61.45	—	—
6	THC072*3,4,W	27	92.18	2	18	61.45	9	30.73
6	THC072*3,4,W	36	122.9	2	18	61.45	18	61.45
6	THC074*3,4	9	30.73	1	9	30.73	—	—

**Table 152. Auxiliary electric heat capacity — 3 to 10 tons (continued)**

Tons	Unit Model Number	Total <sup>(a)</sup>		No. of Stages	Stage 1		Stage 2	
		kw Input <sup>(b)</sup>	MBh Output		kw Input	MBh Output	kw Input	MBh Output
6	THC074*3,4	18	61.45	1	18	61.45	—	—
6	THC074*3,4	27	92.18	2	18	61.45	9	30.73
6	THC074*3,4	36	122.9	2	18	61.45	18	61.45
7.5	TSC090*3,4,W	9	30.73	1	9	30.73	—	—
7.5	TSC090*3,4,W	18	61.45	1	18	61.45	—	—
7.5	TSC090*3,4,W	27	92.18	2	18	61.45	9	30.73
7.5	TSC090*3,4,W	36	122.9	2	18	61.45	18	61.45
7.5	TSC092*3,4,W	9	30.73	1	9	30.73	—	—
7.5	TSC092*3,4,W	18	61.45	1	18	61.45	—	—
7.5	TSC092*3,4,W	27	92.18	2	18	61.45	9	30.73
7.5	TSC092*3,4,W	36	122.9	2	18	61.45	18	61.45
7.5	THC092F3,4,W	9	30.73	1	9	30.73	—	—
7.5	THC092F3,4,W	18	61.45	1	18	61.45	—	—
7.5	THC092F3,4,W	27	92.18	2	18	61.45	9	30.73
7.5	THC092F3,4,W	36	122.9	2	18	61.45	18	61.45
8.5	TSC102*3,4,W	9	30.73	1	9	30.73	—	—
8.5	TSC102*3,4,W	18	61.45	1	18	61.45	—	—
8.5	TSC102*3,4,W	27	92.18	2	18	61.45	9	30.73
8.5	TSC102*3,4,W	36	122.9	2	18	61.45	18	61.45
8.5	THC102F3,4,W	9	30.73	1	9	30.73	—	—
8.5	THC102F3,4,W	18	61.45	1	18	61.45	—	—
8.5	THC102F3,4,W	27	92.18	2	18	61.45	9	30.73
8.5	THC102F3,4,W	36	122.9	2	18	61.45	18	61.45
10	TSC120*3,4,W	18	61.45	1	18	61.45	—	—
10	TSC120*3,4,W	27	92.18	2	18	61.45	9	30.73
10	TSC120*3,4,W	36	122.9	2	18	61.45	18	61.45
10	TSC120*3,4,W	54	184.36	2	36	122.9	18	61.45
10	THC120F3,4	18	61.45	1	18	61.45	—	—
10	THC120F3,4	27	92.18	2	18	61.45	9	30.73
10	THC120F3,4	36	122.9	2	18	61.45	18	61.45
10	THC120F3,4	54	184.36	2	36	122.9	18	61.45

<sup>(a)</sup> Heaters are rated at 240V,380V,480V and 600V. For other than rated voltage, CAP= (voltage/rated voltage)<sup>2</sup> x rated cap.

<sup>(b)</sup> All input/output does not include indoor fan power or heat.

**Table 153. Electric heater voltage correction factors (applicable to auxiliary heat capacity)**

Nominal Voltage	Distribution Voltage	Capacity Multiplier
240	208	0.751
240	230	0.918
240	240	1
480	440	0.84
480	460	0.918
480	480	1
600	540	0.81
600	575	0.918
600	600	1

**Table 154. 3 to 5 tons air temperature rise across electric heaters (°F)**

kW	Stages	3 Tons <sup>(a)</sup> 1200 cfm	4 Tons 1600 cfm	5 Tons <sup>(b)</sup> 2000 cfm
		Three Phase T*C036E3,E4,EW	Three Phase T*C048E/F3,E/F4,EW	Three Phase T*C060E/F3,E/F4,EW
5.00	1	—	—	—
6.00	1	18.5	10.5	11.4
10.00	2	—	—	—



## Heating Performance

**Table 154. 3 to 5 tons air temperature rise across electric heaters (°F) (continued)**

kW	Stages	3 Tons <sup>(a)</sup> 1200 cfm	4 Tons 1600 cfm	5 Tons <sup>(b)</sup> 2000 cfm
		Three Phase T*C036E3,E4,EW	Three Phase T*C048E/F3,E/F4,EW	Three Phase T*C060E/F3,E/F4,EW
12.00	2	36.2	22.3	21.5
13.80	2	—	—	—
17.40	2	48.2	33	30
17.60	2	—	—	—
23.00	2	—	—	38.8

**Notes:**

1. For minimum design airflow, see airflow performance table for each unit.
2. To calculate temp rise at different airflow, use the following formula: Temp. rise across electric heater = kWx3414/1.08xcfm.

<sup>(a)</sup> The minimum allowable airflow for a 3 ton with a 17.4 kW heater is 1080 cfm.

<sup>(b)</sup> The minimum allowable airflow for a 5 ton unit with a 23.0 kW heater is 1900 cfm.

**Table 155. 6 to 10 tons air temperature rise across electric heaters (°F)**

kW	Stages	6 Tons 2000 cfm	7.5 Tons 1600 cfm	8.5 Tons 3400 cfm	10 Tons 4000 cfm <sup>(a)</sup>
		TSC072H3,4,W THC072F3,4,W THC074F3,4	TSC090H3,4,W TSC092H3,4,W THC092F3,4,W	TSC102H3,4,W THC102F3,4,W	TSC120H3,4,W THC120F3,4
9.00	1	14.2	9.5	8.4	—
18.00	1	28.5	19.0	16.7	14.2
27.00	2	42.7	28.5	25.1	21.3
36.00	2	56.9	37.9	33.5	28.5
54.00	2	—	—	—	42.7

**Notes:**

1. For minimum design airflow, see airflow performance table for each unit.
2. To calculate temp rise at different airflow, use the following formula: Temp. rise across electric heater = kWx3414/1.08xcfm.

<sup>(a)</sup> Minimum allowable airflow with a 54 kW heater for the TSC120F and THC120F is 3400 cfm.

**Table 156. Reheat temperature rise table**

Leaving Evaporator Dry Bulb									
Tons	Unit Model No.	CFM	35	40	45	50	55	60	65
3	THC	600	26.3	24.6	22.8	21.0	19.2	17.5	15.8
3	THC	720	24.4	22.8	21.1	19.4	17.7	16.1	14.6
3	THC	840	22.8	21.3	19.8	18.3	16.7	15.2	13.7
3	T/YHC	960	21.3	20.0	18.6	17.2	15.7	14.3	13.0
3	T/YHC	1080	20.0	18.8	17.5	16.2	14.9	13.6	12.3
3	T/YHC	1200	18.9	17.7	16.5	15.3	14.1	12.9	11.7
3	T/YHC	1320	17.9	16.8	15.7	14.6	13.4	12.2	11.1
3	T/YHC	1440	17.0	16.0	14.9	13.9	12.8	11.7	10.6
4	THC	800	18.1	16.7	15.4	14.1	12.8	11.6	10.6
4	THC	960	16.5	15.3	14.1	12.9	11.7	10.6	9.6
4	THC	1120	15.1	14.0	12.9	11.9	10.8	9.8	8.8
4	T/YHC	1280	14.0	13.0	12.0	11.0	10.0	9.1	8.2
4	T/YHC	1440	13.1	12.2	11.3	10.3	9.4	8.5	7.7
4	T/YHC	1600	12.3	11.4	10.6	9.7	8.8	8.0	7.2
4	T/YHC	1760	11.6	10.8	10.0	9.2	8.4	7.6	6.8
4	T/YHC	1920	10.9	10.2	9.4	8.7	7.9	7.2	6.4
5	THC	1000	24.4	22.9	21.5	20.1	18.8	17.4	16.1
5	THC	1200	22.4	21.1	19.8	18.5	17.3	16.1	14.9
5	THC	1400	20.8	19.6	18.4	17.2	16.1	15.0	13.9
5	T/YHC	1600	19.4	18.3	17.2	16.1	15.0	14.0	13.0
5	T/YHC	1800	18.1	17.1	16.1	15.1	14.2	13.2	12.2
5	T/YHC	2000	17.0	16.1	15.2	14.3	13.4	12.4	11.5
5	T/YHC	2200	16.1	15.3	14.4	13.5	12.6	11.8	10.9
5	T/YHC	2400	15.2	14.4	13.7	12.8	12.0	11.2	10.4

**Table 156. Reheat temperature rise table (continued)**

Leaving Evaporator Dry Bulb									
Tons	Unit Model No.	CFM	35	40	45	50	55	60	65
6	THC	1200	27.4	25.3	23.5	21.8	20.3	18.9	17.7
6	THC	1680	22.7	20.9	19.3	17.9	16.6	15.4	14.4
6	THC	1920	21.0	19.3	17.8	16.4	15.2	14.1	13.1
6	T/YHC	2160	19.4	17.8	16.4	15.2	14.1	13.1	12.2
6	T/YHC	2400	18.0	16.5	15.3	14.1	13.1	12.2	11.3
6	T/YHC	2640	16.8	15.5	14.3	13.2	12.3	11.4	10.6
6	T/YHC	2880	12.7	11.8	11.0	10.4	9.7	9.2	8.7
7.5	THC	1500	36.7	39.1	41.2	43.1	44.9	46.4	47.8
7.5	THC	1800	30.2	32.2	33.9	35.3	36.3	37.0	37.3
7.5	THC	2100	25.4	27.1	28.6	29.8	30.7	31.3	31.7
7.5	T/YHC	2400	21.9	23.4	24.7	25.8	26.6	27.3	27.7
7.5	T/YHC	2700	19.3	20.6	21.8	22.8	23.6	24.3	24.8
7.5	T/YHC	3000	17.1	18.3	19.4	20.3	21.1	21.7	22.2
7.5	T/YHC	3300	15.5	16.6	17.6	18.5	19.3	19.9	20.4
7.5	T/YHC	3600	14.1	15.1	16.0	16.7	17.5	18.1	18.6
8.5	THC	1700	34.4	36.8	39.0	41.0	42.8	44.5	46.0
8.5	THC	2040	28.3	30.4	32.2	33.8	35.2	36.4	37.4
8.5	THC	2380	24.0	25.9	27.5	29.0	30.2	31.3	32.2
8.5	T/YHC	2720	20.9	22.5	24.0	25.3	26.4	27.3	28.1
8.5	T/YHC	3060	18.4	19.9	21.3	22.5	23.5	24.4	25.1
8.5	T/YHC	3400	16.4	17.8	19.1	20.2	21.2	22.0	22.7
8.5	T/YHC	3740	14.8	16.2	17.4	18.4	19.4	20.1	20.8
8.5	T/YHC	4080	13.5	14.7	15.8	16.8	17.7	18.4	19.0
10	THC	2000	31.4	33.8	36.2	38.5	40.7	42.9	45.0
10	THC	2400	26.1	28.2	30.2	32.1	34.0	35.9	37.7
10	THC	2800	23.1	24.9	26.6	28.4	30.1	31.8	33.4
10	T/YHC	3200	19.6	21.2	22.8	24.4	25.9	27.4	28.9
10	T/YHC	3600	17.3	18.8	20.2	21.6	23.0	24.3	25.6
10	T/YHC	4000	15.5	16.8	18.1	19.4	20.6	21.8	23.0
10	T/YHC	4400	14.1	15.3	16.5	17.6	18.8	19.9	21.0
10	T/YHC	4800	13.0	14.1	15.2	16.3	17.4	18.5	19.5



# Controls

## ReliaTel™

Zone sensors are the building occupant's comfort control devices. The following zone sensor options are available for units with ReliaTel™ control.

**Note:** Zone sensor required for units configured for single zone VAV indoor fan control to enable single zone VAV functionality.

## Economizer Controls

The standard equipment offering is a fixed dry bulb changeover control. In addition, there are two optional controls, enthalpy and differential enthalpy control.

### Enthalpy Control

Replaces the dry bulb control with a wet bulb changeover controller which has a fully adjustable setpoint. Enthalpy control offers a higher level of comfort control, along with energy savings potential, than the standard dry bulb control. This is due to the additional wet bulb sensing capability.

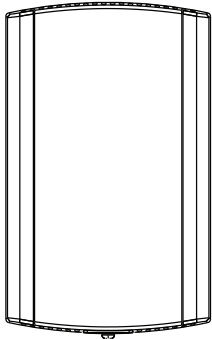
### Differential Enthalpy

Differential enthalpy replaces the standard dry bulb control with two enthalpy sensors that compare total heat content of the indoor air and outdoor air to determine the most efficient air source. This control option offers the highest level of comfort control, plus energy efficiency, available.

## Remote Potentiometer

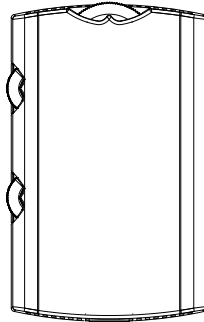
Minimum position setting of economizer can be remotely adjusted with this accessory.

**Remote Sensor**



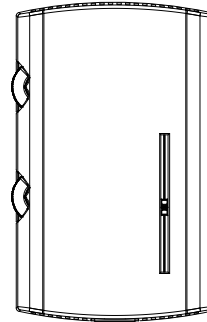
Sensor(s) available for all zone sensors to provide remote sensing capabilities.

**Manual Changeover**



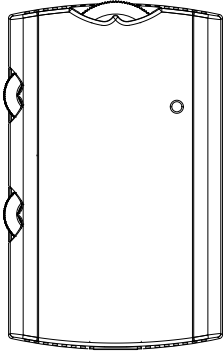
Heat, Cool or Off System Switch. Fan Auto or Off Switch. One temperature setpoint lever.

**Manual/Automatic Changeover**



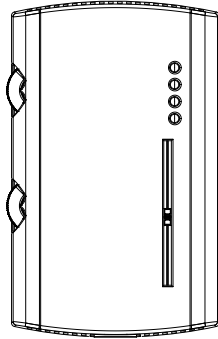
Auto, Heat, Cool or Off System Switch. Fan Auto or Off Switch. Two temperature setpoint levers.

**Manual/Automatic Changeover – Status Indicator**



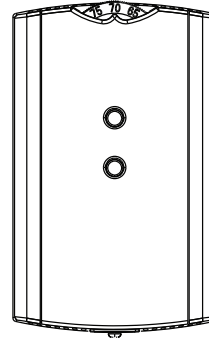
Auto, Heat, Cool or Off System Switch. Fan Auto or Off Switch. Two temperature setpoint levers. Includes a status indicator.

**Manual/Automatic Changeover – LED Status**



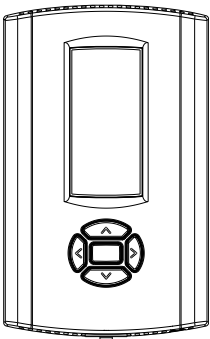
Auto, Heat, Cool or Off System Switch. Fan Auto or Off Switch. Two temperature setpoint levers. Status Indication LED lights, System On, Heat, Cool, or Service.

**Integrated Comfort™ System**



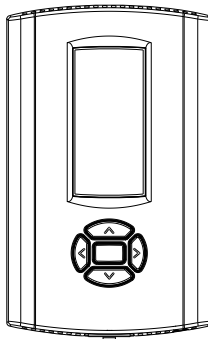
Sensor(s) available with optional temperature adjustment and override buttons to provide central control through a Trane® Integrated Comfort™ system.

**Digital Display Programmable Thermostat (1H/1C)**



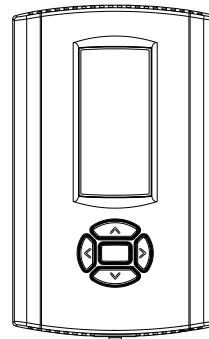
One heat/One Cool Auto changeover digital display thermostat.  
*Not compatible with VAV units.*

**Digital Display Thermostat (3H/2C)**



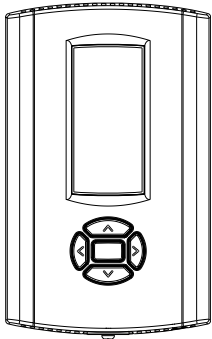
Three Heat, Two Cool Auto changeover digital display thermostat.  
*Not compatible with VAV units.*

**Digital Display Programmable Thermostat (3H/2C) – Night Setback**



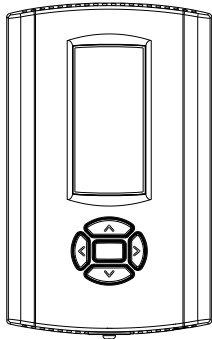
Three Heat/Two Cool Auto changeover digital display thermostat. 7-day programmable stat with night setback is available.  
*Not compatible with VAV units.*

**Programmable Night Setback**



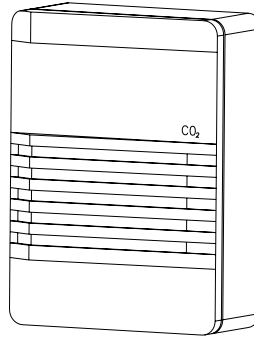
Auto or manual changeover with seven-day programming. Keyboard selection of Heat, Cool, Fan, Auto, or On. All programmable sensors have System On, Heat, Cool, Service LED/indicators as standard. Night Setback Sensors have one (1) Occupied, one (1) Un-occupied, and one (1) Override program per day.

**Wireless Zone Sensor**



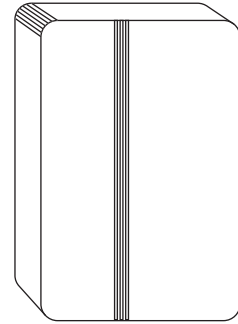
LCD display that provides heat, cool, auto or off. Includes two temperature setpoints and a lockable setting with °F or °C indicators.

**CO<sub>2</sub> Sensing**



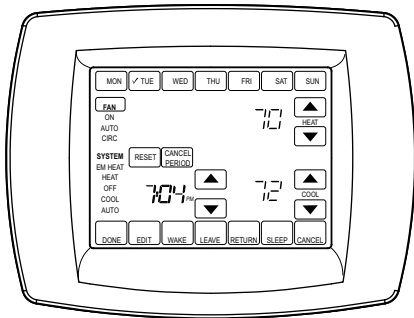
The CO<sub>2</sub> sensor shall have the ability to monitor the concentration (parts per million, ppm) of CO<sub>2</sub> (Carbon Dioxide) in the air. As the CO<sub>2</sub> concentration changes, the outside air damper modulates to meet the current ventilation needs of the zone.

**Humidity Sensor**



Field installed, wall-mounted or duct-mounted humidity sensor is used to control activation of the hot gas reheat dehumidification option. The humidity sensor can be set for humidity levels between 40% and 60% relative humidity by adjusting the ReliaTel™ Options Module.

**Touchscreen Programmable Thermostat (2H/2C)**



Two Heat, Two Cool programmable thermostat with touch screen digital display. Menu-driven programming. Effortless set-up. Program each day separately with no need to copy multiple days. All programming can be done on one screen. Easy to read and use. Large, clear backlit digital display.

*Not compatible with VAV units.*

**Digital Display Programmable Thermostat with Built-In Relative Humidity Sensing (3H/2C)**



Three Heat, Two Cool digital display thermostat with built-in humidity control and display. This thermostat combines both humidity and dry bulb into one.

*Not compatible with VAV units.*

**Differential Pressure Switches**

This factory or field-installed option allows individual fan failure and dirty filter indication. The fan failure switch will disable all unit functions and “flash” the Service LED on the zone sensor. The dirty filter switch will light the Service LED on the zone sensor and will allow continued unit operation.

**Dual Thermistor Remote Zone Sensor**

Space Remote Sensor which can be mounted on the wall to report/control from a remote location in the space.



---

## RA Remote Sensor

Return air remote sensor which can be mounted in the return air duct to report return air temperature.

## Room Remote Sensor

Space remote sensor which can be mounted on the wall to report/control from a remote location in the space.

## Communication Interfaces

### BACnet® Communication Interface

This option shall be provided to allow the unit to communicate directly with a generic open protocol BACnet® MS/TP Network Building Automation System Controls.

### Trane® Air-Fi® Wireless Communication - Factory Installed

Air-Fi Wireless communication shall be factory installed and tested. Air-Fi Wireless conforms to ANSI/ASHRAE Standard 135-2016 (BACnet®/ZigBee®).

### Trane® Communication Interface (TCI)

This factory or field-installed micro-processor interface allows the unit to communicate through a Trane® Integrated Comfort™ system. TCI communication is only for constant volume units. Multi-speed and VAV units require either a BACnet® or LON communication if a BAS is used for control.

### LonTalk® Communications Interface - Factory or Field Installed

The LonTalk® communications interface allows the unit to communicate as a Tracer® LCI-V device or directly with a generic open protocol BACnet® MS/TP Network Building Automation System Controls.

---

<sup>1</sup> ZigBee is a registered trademark of the ZigBee Alliance.



# Electrical Data

Table 157. Unit wiring – standard efficiency

Tons	Unit Model Number	Voltage Range	Standard Indoor Fan Motor <sup>(a)</sup>		Oversized Indoor Fan Motor <sup>(b)</sup>		Optional EBM Fan Motor	
			MCA	Max Fuse Size or Max Circuit Breaker	MCA	Max Fuse Size or Max Circuit Breaker	MCA	Max Fuse Size or Max Circuit Breaker
3	T/YSC036G3	187-253	20	30	23	30	—	—
3	T/YSC036G4	414-506	10	15	12	15	—	—
3	T/YSC036GW	517-633	8	15	9	15	—	—
4	T/YSC048G3	187-253	26	35	27	40	—	—
4	T/YSC048G4	414-506	11	15	13	15	—	—
4	T/YSC048GW	517-633	10	15	11	15	—	—
5	T/YSC060G3	187-253	29	40	30	45	—	—
5	T/YSC060G4	414-506	13	15	14	20	—	—
5	T/YSC060GW	517-633	10	15	11	15	—	—
6	T/YSC072H3	187-253	35	50	38	50	—	—
6	T/YSC072H4	414-506	17	25	18	25	—	—
6	T/YSC072HW	517-633	13	20	14	20	—	—
7.5	T/YSC090H3	187-253	39	60	45	70	—	—
7.5	T/YSC090H4	414-506	19	30	22	30	—	—
7.5	T/YSC090HW	517-633	15	20	17	25	—	—
7.5	T/YSC092H3	187-253	39	50	45	50	43	50
7.5	T/YSC092H4	414-506	18	20	21	25	20	25
7.5	T/YSC092HW	517-633	15	20	17	20	22	25
8.5	T/YSC102H3	187-253	46	60	49	60	47	60
8.5	T/YSC102H4	414-506	23	25	23	25	22	30
8.5	T/YSC102HW	517-633	17	20	17	20	22	25
10	T/YSC120H3	187-253	49	60	—	—	—	—
10	T/YSC120H4	414-506	22	25	—	—	—	—
10	T/YSC120HW	517-633	22	25	—	—	—	—

**Note:** T/YSC092F (7.5 ton) models have a dual refrigeration system.

- <sup>(a)</sup> The standard motor for 3-phase (3 to 5 ton models) is a multispeed, direct drive motor. The standard motor for 3-phase (6 to 8.5 ton models) is a belt drive motor.
- <sup>(b)</sup> The oversized motor for 3-phase (3 to 5 ton models) is a multispeed, direct drive motor. The oversized motor for 3-phase (6 to 8.5 ton models) is a belt drive motor.

**Table 158. Unit wiring with electric heat (single point connection) — standard efficiency**

Tons	Unit Model Number	Heater Model Number	Heater kW Rating	Control Stages	Standard Indoor Fan Motor <sup>(a)</sup>		Oversized Indoor Fan Motor <sup>(b)</sup>		Optional EBM Fan Motor	
					MCA	Max Fuse Size or Max Circuit Breaker	MCA	Max Fuse Size or Max Circuit Breaker	MCA	Max Fuse Size or Max Circuit Breaker
<b>208/230 Volts Three Phase</b>										
3	TSC036G3	BAYHTRE306*	4.5/6.0	1	23/26	30/30	26/29	30/30	—	—
3	TSC036G3	BAYHTRE312*	9.0/12.0	2	39/44	40/45	42/47	45/50	—	—
3	TSC036G3	BAYHTRE318*	13.1/17.4	2	53/60	60/60	56/63	60/70	—	—
4	TSC048G3	BAYHTRE306*	4.5/6.0	1	26/27	35/35	27/29	40/40	—	—
4	TSC048G3	BAYHTRE312*	9.0/12.0	2	40/45	40/45	42/47	45/50	—	—
4	TSC048G3	BAYHTRE318*	13.1/17.4	2	54/61	60/70	56/63	60/70	—	—
5	TSC060G3	BAYHTRE306*	4.5/6.0	1	29/29	40/40	30/30	45/45	—	—
5	TSC060G3	BAYHTRE312*	9.0/12.0	2	40/45	40/45	42/47	45/50	—	—
5	TSC060G3	BAYHTRE318*	13.1/17.4	2	54/61	60/70	56/63	60/70	—	—
5	TSC060G3	BAYHTRE323*	17.3/23.0	2	69/78	70/80	71/80	80/80	—	—
6	TSC072H3	BAYHTRS309*	6.8/9.0	1	35/35	50/50	38/38	50/50	—	—
6	TSC072H3	BAYHTRS318*	13.5/18.0	1	53/60	60/60	56/64	60/70	—	—
6	TSC072H3	BAYHTRS327*	20.3/27.0	2	76/87	80/90	80/91	80/100	—	—
6	TSC072H3	BAYHTRS336*	27.0/36.0	2	100/114	100/125	103/118	110/125	—	—
7.5	TSC090H3	BAYHTRW309*	6.8/9.0	1	39/39	60/60	45/45	70/70	—	—
7.5	TSC090H3	BAYHTRW318*	13.5/18.0	1	53/60	60/60	60/67	70/70	—	—
7.5	TSC090H3	BAYHTRW327*	20.3/27.0	2	76/87	80/90	84/94	90/100	—	—
7.5	TSC090H3	BAYHTRW336*	27.0/36.0	2	99/114	100/125	107/122	110/125	—	—
7.5	TSC092H3	BAYHTRT309* BAYHTRA309 <sup>(c)</sup>	6.8/9.0	1	39/39	50/50	45/45	50/50	43/43	50/50
7.5	TSC092H3	BAYHTRT318* BAYHTRZ318 <sup>(c)</sup>	13.5/18.0	1	53/60	60/60	60/67	60/70	58/65	60/70
7.5	TSC092H3	BAYHTRT327* BAYHTRA327 <sup>(c)</sup>	20.3/27.0	2	76/87	80/90	84/94	90/100	81/92	90/100
7.5	TSC092H3	BAYHTRT336* BAYHTRZ336 <sup>(c)</sup>	27.0/36.0	2	99/114	100/125	107/122	110/125	104/119	110/125
8.5	TSC102H3	BAYHTRT309* BAYHTRA309 <sup>(c)</sup>	6.8/9.0	1	46/46	60/60	49/49	60/60	47/47	60/60
8.5	TSC102H3	BAYHTRT318* BAYHTRZ318 <sup>(c)</sup>	13.5/18.0	1	56/64	60/70	60/67	60/70	58/65	60/70
8.5	TSC102H3	BAYHTRT327* BAYHTRA327 <sup>(c)</sup>	20.3/27.0	2	80/91	80/100	84/94	90/100	81/92	90/100
8.5	TSC102H3	BAYHTRT336* BAYHTRZ336 <sup>(c)</sup>	27.0/36.0	2	103/118	110/125	107/122	110/125	104/119	110/125
10	TSC120H3	BAYHTRZ318*	13.5/18.0	1	58/65	60/70	—/—	—/—	—	—
10	TSC120H3	BAYHTRA327*	20.3/27.0	2	81/92	90/100	—/—	—/—	—	—
10	TSC120H3	BAYHTRZ336*	27.0/36.0	2	104/119	110/125	—/—	—/—	—	—
10	TSC120H3	BAYHTRA354*	40.6/54.0	2	151/141	175/175	—/—	—/—	—	—



**Electrical Data**

**Table 158. Unit wiring with electric heat (single point connection) — standard efficiency (continued)**

Tons	Unit Model Number	Heater Model Number	Heater kW Rating	Control Stages	Standard Indoor Fan Motor <sup>(a)</sup>		Oversized Indoor Fan Motor <sup>(b)</sup>		Optional EBM Fan Motor	
					MCA	Max Fuse Size or Max Circuit Breaker	MCA	Max Fuse Size or Max Circuit Breaker	MCA	Max Fuse Size or Max Circuit Breaker
<b>460 Volts Three Phase</b>										
3	TSC036G4	BAYHTRE406*	6	1	12	15	15	15	—	—
3	TSC036G4	BAYHTRE412*	12	2	21	25	24	25	—	—
3	TSC036G4	BAYHTRE418*	17.4	2	29	30	32	35	—	—
4	TSC048G4	BAYHTRE406*	6	1	13	15	15	15	—	—
4	TSC048G4	BAYHTRE412*	12	2	22	25	24	25	—	—
4	TSC048G4	BAYHTRE418*	17.4	2	30	30	32	35	—	—
5	TSC060G4	BAYHTRE406*	6	1	13	15	15	20	—	—
5	TSC060G4	BAYHTRE412*	12	2	22	25	24	25	—	—
5	TSC060G4	BAYHTRE418*	17.4	2	30	30	32	35	—	—
5	TSC060G4	BAYHTRE423*	23	2	38	40	40	40	—	—
6	TSC072H4	BAYHTRS409*	9	1	17	25	19	25	—	—
6	TSC072H4	BAYHTRS418*	18	1	31	35	32	35	—	—
6	TSC072H4	BAYHTRS427*	27	2	44	45	46	50	—	—
6	TSC072H4	BAYHTRS436*	36	2	58	60	60	60	—	—
7.5	TSC090H4	BAYHTRW409*	9	1	19	30	22	30	—	—
7.5	TSC090H4	BAYHTRW418*	18	1	31	35	34	35	—	—
7.5	TSC090H4	BAYHTRW427*	27	2	44	45	48	50	—	—
7.5	TSC090H4	BAYHTRW436*	36	2	58	60	61	70	—	—
7.5	TSC092H4	BAYHTRT409* BAYHTRA409 <sup>(c)</sup>	9	1	18	20	21	25	20	25
7.5	TSC092H4	BAYHTRT418* BAYHTRA418 <sup>(c)</sup>	18	1	31	35	34	35	33	35
7.5	TSC092H4	BAYHTRT427* BAYHTRA427 <sup>(c)</sup>	27	2	44	45	48	50	47	50
7.5	TSC092H4	BAYHTRT436* BAYHTRA436 <sup>(c)</sup>	36	2	58	60	61	70	60	60
8.5	TSC102H4	BAYHTRT409* BAYHTRA409 <sup>(c)</sup>	9	1	21	25	23	25	22	25
8.5	TSC102H4	BAYHTRT418* BAYHTRA418 <sup>(c)</sup>	18	1	32	35	34	35	33	35
8.5	TSC102H4	BAYHTRT427* BAYHTRA427 <sup>(c)</sup>	27	2	46	50	48	50	47	50
8.5	TSC102H4	BAYHTRT436* BAYHTRA436 <sup>(c)</sup>	36	2	60	60	61	70	60	60
10	TSC120H4	BAYHTRA418*	18	1	33	35	—	—	—	—
10	TSC120H4	BAYHTRA427*	27	2	47	50	—	—	—	—
10	TSC120H4	BAYHTRA436*	36	2	60	60	—	—	—	—
10	TSC120H4	BAYHTRA454*	54	2	71	90	—	—	—	—

**Table 158. Unit wiring with electric heat (single point connection) — standard efficiency (continued)**

Tons	Unit Model Number	Heater Model Number	Heater kW Rating	Control Stages	Standard Indoor Fan Motor <sup>(a)</sup>		Oversized Indoor Fan Motor <sup>(b)</sup>		Optional EBM Fan Motor	
					MCA	Max Fuse Size or Max Circuit Breaker	MCA	Max Fuse Size or Max Circuit Breaker	MCA	Max Fuse Size or Max Circuit Breaker
<b>575 Volts Three Phase</b>										
3	TSC036GW	BAYHTREW06*	6	1	11	15	12	15	—	—
3	TSC036GW	BAYHTREW12*	12	2	18	20	19	20	—	—
3	TSC036GW	BAYHTREW18*	17.4	2	24	25	26	30	—	—
4	TSC048GW	BAYHTREW06*	6	1	11	15	12	15	—	—
4	TSC048GW	BAYHTREW12*	12	2	18	20	19	20	—	—
4	TSC048GW	BAYHTREW18*	17.4	2	25	25	26	30	—	—
5	TSC060GW	BAYHTREW06*	6	1	11	15	12	15	—	—
5	TSC060GW	BAYHTREW12*	12	2	18	20	19	20	—	—
5	TSC060GW	BAYHTREW18*	17.4	2	25	25	26	30	—	—
5	TSC060GW	BAYHTREW23*	23	2	32	35	33	35	—	—
6	TSC072HW	BAYHTRSW18*	18	1	25	25	26	30	—	—
6	TSC072HW	BAYHTRSW27*	27	2	36	40	37	40	—	—
6	TSC072HW	BAYHTRSW36*	36	2	47	50	48	50	—	—
7.5	TSC090HW	BAYHTRWW18*	18	1	25	25	27	30	—	—
7.5	TSC090HW	BAYHTRWW27*	27	2	36	40	38	40	—	—
7.5	TSC090HW	BAYHTRWW36*	36	2	47	50	49	50	—	—
7.5	TSC092HW	BAYHTRTW18* BAYHTRAW18 <sup>(c)</sup>	18	1	25	25	27	30	32	35
7.5	TSC092HW	BAYHTRTW27* (No kit for 27kW) <sup>(c)</sup>	27	2	36	40	38	40	43	45
7.5	TSC092HW	BAYHTRTW36* BAYHTRAW36 <sup>(c)</sup>	36	2	47	50	49	50	54	60
8.5	TSC102HW	BAYHTRTW18* BAYHTRAW18 <sup>(c)</sup>	18	1	26	30	27	30	32	35
8.5	TSC102HW	BAYHTRTW27* (No kit for 27kW) <sup>(c)</sup>	27	2	37	40	38	40	—	—
8.5	TSC102HW	BAYHTRTW36* BAYHTRAW36 <sup>(c)</sup>	36	2	48	50	49	50	54	60
10	TSC120HW	BAYHTRAW18*	18	1	32	35	—	—	—	—
10	TSC120HW	BAYHTRAW36*	36	2	54	60	—	—	—	—
10	TSC120HW	BAYHTRAW54*	54	2	63	70	—	—	—	—

**Note:** T/YSC092H (7.5 ton) models have a dual refrigeration system.

<sup>(a)</sup> The standard motor is a multispeed, direct drive motor. The standard motor for 3-phase (6 to 8.5 ton models) is a belt drive motor.

<sup>(b)</sup> The oversized motor for 3-phase (3 to 5 ton models) is a multispeed, direct drive motor. The oversized motor for 3-phase (6 to 8.5 ton models) is a belt drive motor.

<sup>(c)</sup> Kit used with Title 24/SZVAV models.



**Electrical Data**

**Table 159. Electrical characteristics – compressor motor and condenser motor – 60 cycle – standard efficiency**

Tons	Unit Model Number	No.	Compressor Motors						No.	Condenser Fan Motor				
			Volts	Phase	hp <sup>(a)</sup>	rpm	Amps <sup>(b)</sup>			Volts	Phase	hp	Amps	
							RLA	LRA					FLA	LRA
3	T/YSC036G3	1	208-230	3	2.8	3500	10.4	73	1	208-230	3	0.25	1.1	3.6
3	T/YSC036G4	1	460	3	2.8	3500	5.8	45	1	460	3	0.25	0.55	1.8
3	T/YSC036GW	1	575	3	2.8	3500	3.8	36.5	1	575	3	0.25	0.45	1.4
4	T/YSC048G3	1	208-230	3	3.6	3500	13.7	83.1	1	208-230	3	0.33	1.4	4.6
4	T/YSC048G4	1	460	3	3.6	3500	6.2	41	1	460	3	0.33	0.7	2.3
4	T/YSC048GW	1	575	3	3.5	3500	4.8	33	1	575	3	0.33	0.55	1.8
5	T/YSC060G3	1	208-230	3	4.3	3500	15.9	110	1	208-230	3	0.4	1.4	5.2
5	T/YSC060G4	1	460	3	4.3	3500	7.1	52	1	460	3	0.4	0.7	2.6
5	T/YSC060GW	1	575	3	4.3	3500	5.1	40	1	575	3	0.4	0.6	2.1
6	T/YSC072H3	1	208-230	3	5.6	3500	22.4	149	1	208-230	3	0.7	3.3	12.3
6	T/YSC072H4	1	460	3	5.6	3500	10.6	75	1	460	3	0.7	1.5	6.1
6	T/YSC072HW	1	575	3	5.6	3500	7.7	54	1	575	3	0.7	1.4	5.1
7.5	T/YSC090H3	1	208-230	3	6.7	3500	29	208	1	208-230	3	0.7	3.3	12.3
7.5	T/YSC090H4	1	460	3	6.7	3500	12.2	100	1	460	3	0.7	1.5	6.1
7.5	T/YSC090HW	1	575	3	6.7	3500	11	78	1	575	3	0.7	1.4	5.1
7.5	T/YSC092H3	1	208-230	3	3.7/3.1	3500/3500	14.5/14	98.0/83.1	1	208-230	3	0.7	3.3	12.3
7.5	T/YSC092H4	1	460	3	3.7/3.1	3500/3500	6.3/6.27	55.0/41.0	1	460	3	0.7	1.5	6.1
7.5	T/YSC092HW	1	575	3	3.7/3.1	3500/3500	6/4.29	41.0/33.0	1	575	3	0.7	1.4	5.1
8.5	T/YSC102H3	2	208-230	3	3.7/3.7	3500/3500	20/13.72	180/83.1	1	208-230	3	0.7	3.3	12.3
8.5	T/YSC102H4	2	460	3	3.7/3.7	3500/3500	9/6.22	68/41.0	1	460	3	0.7	1.5	6.1
8.5	T/YSC102HW	2	575	3	3.7/3.7	3500/3500	6/4.81	58/33	1	575	3	0.7	1.4	5.1
10	T/YSC120H3	2	208-230	3	4.8/3.7	3500/3500	19.6/13.1	136.0/83.1	1	208-230	3	0.7	3.3	12.3
10	T/YSC120H4	2	460	3	4.8/3.7	3500/3500	8.2/6.1	66.1/41.0	1	460	3	0.7	1.5	6.1
10	T/YSC120HW	2	575	3	4.8/3.7	3500/3500	6.6/4.4	55.3/33.0	1	575	3	0.7	1.4	5.1

<sup>(a)</sup> hp for each compressor

<sup>(b)</sup> Amp draw for each motor (compressor and standard indoor fan motor); multiply value by number of motors to determine total amps.

**Table 160. Electrical characteristics – standard evaporator fan motor – 60 cycle – direct or belt drive standard efficiency**

Tons	Unit Model Number	Direct or Belt Drive	No.	Volts	Phase	hp	Amps	
							FLA	LRA
3	T/YSC036G3	Direct Drive	1	208-230	1	0.75	5.7	—
3	T/YSC036G4	Direct Drive	1	460	1	0.75	1.7	—
3	T/YSC036GW	Direct Drive	1	575	1	0.75	2.4	—
4	T/YSC048G3	Direct Drive	1	208-230	1	1	6.9	—
4	T/YSC048G4	Direct Drive	1	460	1	1	2.5	—
4	T/YSC048GW	Direct Drive	1	575	1	1	2.9	—
5	T/YSC060G3	Direct Drive	1	208-230	1	1	6.9	—
5	T/YSC060G4	Direct Drive	1	460	1	1	2.5	—
5	T/YSC060GW	Direct Drive	1	575	1	1	2.9	—
6	T/YSC072H3	Belt Drive	1	208-230	3	1	3.4	32.2

**Table 160. Electrical characteristics — standard evaporator fan motor – 60 cycle — direct or belt drive standard efficiency (continued)**

Tons	Unit Model Number	Direct or Belt Drive	No.	Volts	Phase	hp	Amps	
							FLA	LRA
6	T/YSC072H4	Belt Drive	1	460	3	1	1.6	16.1
6	T/YSC072HW	Belt Drive	1	575	3	1	1.7	13.2
7.5	T/YSC090H3	Belt Drive	1	208-230	3	1	3.3	12.5
7.5	T/YSC090H4	Belt Drive	1	460	3	1	1.6	12.5
7.5	T/YSC090HW	Belt Drive	1	575	3	1	1.4	10
7.5	T/YSC092H3	Belt Drive	1	208-230	3	1	3.3	12.5
7.5	T/YSC092H4	Belt Drive	1	460	3	1	1.6	12.5
7.5	T/YSC092HW	Belt Drive	1	575	3	1	1.4	10
7.5	T/YSC092H3	Direct Drive	1	208-230	3	2.75	7.3	—
7.5	T/YSC092H4	Direct Drive	1	460	3	2.75	3.6	—
7.5	T/YSC092HW	Direct Drive	1	575	3	2.75	7.5	—
8.5	T/YSC102H3	Belt Drive	1	208-230	3	2	6.3	48
8.5	T/YSC102H4	Belt Drive	1	460	3	2	3.1	24
8.5	T/YSC102HW	Belt Drive	1	575	3	2	2.5	18.2
8.5	T/YSC102H3	Direct Drive	1	208-230	3	2.75	7.3	—
8.5	T/YSC102H4	Direct Drive	1	460	3	2.75	3.6	—
8.5	T/YSC102HW	Direct Drive	1	575	3	2.75	7.5	—
10	T/YSC120H3	Direct Drive	1	208-230	3	2.75	7.3	—
10	T/YSC120H4	Direct Drive	1	460	3	2.75	3.6	—
10	T/YSC120HW	Direct Drive	1	575	3	2.75	7.5	—

**Notes:**

1. Precedent™ 3 to 5 ton models rated at 575V utilize a 208-230V evaporator Fan motor powered through a 575/230V transformer assembly. Motor voltage/FLA rated at transformer input.
2. Precedent™ 10 ton models rated at 575V utilize a 380-480V evaporator Fan motor powered through a 575/480V transformer assembly. Motor voltage/FLA rated at transformer input.

**Table 161. Electrical characteristics — oversized evaporator fan motor – 60 cycle — belt drive — standard efficiency**

Tons	Unit Model Number	Direct or Belt Drive	No.	Volts	Phase	hp	Amps	
							FLA	LRA
3	T/YSC036G3	Direct Drive	1	208-230	1	1.5	8.2	-
3	T/YSC036G4	Direct Drive	1	460	1	1.5	4.8	-
3	T/YSC036GW	Direct Drive	1	575	1	1.5	3.5	-
4	T/YSC048G3	Direct Drive	1	208-230	1	1.5	8.2	-
4	T/YSC048G4	Direct Drive	1	460	1	1.5	4.8	-
4	T/YSC048GW	Direct Drive	1	575	1	1.5	3.5	-
5	T/YSC060G3	Direct Drive	1	208-230	1	1.5	8.2	-
5	T/YSC060G4	Direct Drive	1	460	1	1.5	4.8	-
5	T/YSC060GW	Direct Drive	1	575	1	1.5	3.5	-
6	T/YSC072H3	Belt Drive	1	208-230	3	2	6.3	48.0
6	T/YSC072H4	Belt Drive	1	460	3	2	3.1	24.0
6	T/YSC072HW	Belt Drive	1	575	3	2	2.5	18.2
7.5	T/YSC090H3	Belt Drive	1	208-230	3	3	9.4	52.4
7.5	T/YSC090H4	Belt Drive	1	460	3	3	4.6	26.3
7.5	T/YSC090HW	Belt Drive	1	575	3	3	3.4	29.4
7.5	T/YSC092H3	Belt Drive	1	208-230	3	3	9.4	83.0
7.5	T/YSC092H4	Belt Drive	1	460	3	3	4.6	42.0
7.5	T/YSC092HW	Belt Drive	1	575	3	3	3.4	31.0



## Electrical Data

**Table 161. Electrical characteristics – oversized evaporator fan motor – 60 cycle – belt drive – standard efficiency (continued)**

Tons	Unit Model Number	Direct or Belt Drive	No.	Volts	Phase	hp	Amps	
							FLA	LRA
8.5	T/YSC102H3	Belt Drive	1	208-230	3	3	9.4	83.0
8.5	T/YSC102H4	Belt Drive	1	460	3	3	4.6	42.0
8.5	T/YSC102HW	Belt Drive	1	575	3	3	3.4	31.0

**Note:** Precedent™ 3 to 5 ton models rated at 575V utilize a 208-230V evaporator Fan motor powered through a 575/230V transformer assembly. Motor voltage/FLA rated at transformer input.

**Table 162. Electrical characteristics – power exhaust (cooling and gas/electric)**

Tons	Volts	Phase	hp	rpm	FLA	LRA
3-5	208-230	1	0.33	1075	2.2	3.9
3-5	460	1	0.33	1075	1.1	2.0
3-5	575	1	0.33	1075	1.0	1.8
6-10	208-230	1	0.87	1075	5.7	13.6
6-10	460	1	0.87	1075	3.3	6.8
6-10	575	1	0.87	1075	2.3	5.4

**Note:** For 6 to 10 ton models, rpm = two speed.

**Table 163. Electrical characteristics – inducer motor**

Unit Model Number	Stages	hp	rpm	Volts	Phase	LRA
YSC(036-060)G**(L,M,H,X,Y,Z)	2	1/50	3200/3500	208-230	1	0.7
YSC072H**(L,M,X,Y), YSC(090-102)H**(L,X)	1	1/35	3000	208-230	1	0.6
YSC072H**(H,Z), YSC(090-102)H**(M,H,Y,Z)	2	1/15	2800/3350	208-230	1	0.4

**Table 164. Unit wiring – high efficiency**

Tons	Unit Model Number	Voltage Range	Standard Indoor Fan Motor		Optional Belt Drive Indoor Fan Motor (a)	
			MCA	Max Fuse Size or Max Circuit Breaker	MCA	Max Fuse Size or Max Circuit Breaker
3	T/YHC036E3	187-253	21	30	18	25
3	T/YHC036E4	414-506	12	15	10	15
3	YHC036EW	517-633	10	15	8	15
4	T/YHC048E_F3	187-253	26	35	24	35
4	T/YHC048E_F4	414-506	13	15	11	15
4	YHC048FW	517-633	11	15	9	15
5	T/YHC060E_F3	187-253	30	45	26	40
5	T/YHC060E_F4	414-506	14	20	12	15
5	YHC060E_FW	517-633	11	15	9	15
6	T/YHC072E_F3	187-253	31	45	24	45
6	T/YHC072E_F4	414-506	15	20	16	20
6	YHC072E_FW	517-633	13	15	14	15
6	T/YHC074F3	187-253	37	50	—	—
6	T/YHC074F4	414-506	18	20	—	—
7.5	T/YHC092F3	187-253	42	50	—	—
7.5	T/YHC092F4	414-506	20	25	—	—
7.5	YHC092FW	517-633	21	25	—	—
8.5	T/YHC102F3	187-253	41	50	—	—
8.5	T/YHC102F4	414-506	21	25	—	—
8.5	YHC102FW	517-633	22	25	—	—
10	T/YHC120F3	187-253	48	60	—	—
10	T/YHC120F4	414-506	22	25	—	—
10	YHC120FW	517-633	22	25	—	—



**Table 164. Unit wiring – high efficiency (continued)**

(a) No optional motors available for 3 to 5 tons.

**Table 165. Unit wiring with electric heat (single point connection) – high efficiency – 3 to 5 tons**

Tons	Unit Model Number	Heater Model Number	Heater kW Rating <sup>(a)</sup>	Control Stages	Standard Indoor Fan Motor		Optional Belt Drive Indoor Motor	
					MCA	Max Fuse Size or Max Circuit Breaker	MCA	Max Fuse Size or Max Circuit Breaker
<b>208/230 Volts Three Phase</b>								
3	THC036E3	BAYHTRE306*	4.5/6.0	1	25/27	30/30	21/24	25/25
3	THC036E3	BAYHTRE312*	9.0/12.0	2	40/45	40/45	37/42	40/45
3	THC036E3	BAYHTRE318*	13.1/17.4	2	54/61	60/70	51/58	60/60
4	THC048E_F3	BAYHTRX306*	4.5/6.0	1	26/27	35/35	24/24	35/35
4	THC048E_F3	BAYHTRX312*	9.0/12.0	2	40/42	40/45	37/42	40/45
4	THC048E_F3	BAYHTRX318*	13.1/17.4	2	54/61	60/70	51/58	60/60
5	THC060E_F3	BAYHTRX306*	4.5/6.0	1	30/30	45/45	26/26	40/40
5	THC060E_F3	BAYHTRX312*	9.0/12.0	2	42/47	45/50	37/42	40/45
5	THC060E_F3	BAYHTRX318*	13.1/17.4	2	56/63	60/70	51/58	60/60
5	THC060E_F3	BAYHTRX323*	17.3/23.0	2	71/80	80/80	66/75	70/80
<b>460 Volts Three Phase</b>								
3	THC036E4	BAYHTRE406*	6.0	1	15	15	13	15
3	THC036E4	BAYHTRE412*	12.0	2	24	25	22	25
3	THC036E4	BAYHTRE418*	17.4	2	32	35	30	30
4	THC048E_F4	BAYHTRX406*	6.0	1	16	20	13	15
4	THC048E_F4	BAYHTRX412*	12.0	2	25	25	22	25
4	THC048E_F4	BAYHTRX418*	17.4	2	33	35	30	30
5	THC060E_F4	BAYHTRX406*	6.0	1	16	20	13	15
5	THC060E_F4	BAYHTRX412*	12.0	2	25	25	22	25
5	THC060E_F4	BAYHTRX418*	17.4	2	33	35	30	30
5	THC060E_F4	BAYHTRX423*	23.0	2	41	45	38	40

(a) Heater kW ratings are at 208/240V for 208/230V units, 480V for 460V units.

**Table 166. Unit wiring with electric heat (single point connection) – high efficiency – 6 to 10 tons**

Tons	Unit Model Number	Heater Model Number	Heater kW Rating <sup>(a)</sup>	Control Stages	Standard Indoor Fan Motor		Oversized Indoor Motor	
					MCA	Max Fuse Size or Max Circuit Breaker	MCA	Max Fuse Size or Max Circuit Breaker
<b>208/230 Volts Three Phase</b>								
6	THC072E/F3	BAYHTRU309*	6.8/9.0	1	31/33	45/45	34/36	50/50
6	THC072*3	BAYHTRU318*	13.5/18.0	1	53/60	60/60	56/64	60/70
6	THC072*3	BAYHTRU327*	20.3/27.0	2	76/87	80/90	80/91	80/100
6	THC072*3	BAYHTRU336*	27.0/36.0	2	100/114	100/125	103/118	110/125
6	THC074F3	BAYHTRA309*	6.8/9.0	1	37/38	50/50	—/—	—/—
6	THC074F3	BAYHTRA318*	13.5/18.0	1	58/65	60/70	—/—	—/—
6	THC074F3	BAYHTRA327*	20.3/27.0	2	81/92	90/100	—/—	—/—
6	THC074F3	BAYHTRA336*	27.0/36.0	2	104/119	110/125	—/—	—/—
7.5	THC092F3	BAYHTRA309*	6.8/9.0	1	42/42	50/50	—/—	—/—
7.5	THC092F3	BAYHTRZ318*	13.5/18.0	1	58/65	60/70	—/—	—/—
7.5	THC092F3	BAYHTRA327*	20.3/27.0	2	81/92	90/100	—/—	—/—
7.5	THC092F3	BAYHTRZ336*	27.0/36.0	2	104/119	110/125	—/—	—/—
8.5	THC102F3	BAYHTRA309*	6.8/9.0	1	41/41	50/50	—/—	—/—
8.5	THC102F3	BAYHTRZ318*	13.5/18.0	1	58/65	60/70	—/—	—/—
8.5	THC102F3	BAYHTRA327*	20.3/27.0	2	81/92	90/100	—/—	—/—
8.5	THC102F3	BAYHTRZ336*	27.0/36.0	2	104/119	110/125	—/—	—/—
10	THC120F3	BAYHTRD318*	13.5/18.0	1	58/65	60/70	—/—	—/—



**Electrical Data**

**Table 166. Unit wiring with electric heat (single point connection) – high efficiency – 6 to 10 tons (continued)**

Tons	Unit Model Number	Heater Model Number	Heater kW Rating <sup>(a)</sup>	Control Stages	Standard Indoor Fan Motor		Oversized Indoor Motor	
					MCA	Max Fuse Size or Max Circuit Breaker	MCA	Max Fuse Size or Max Circuit Breaker
10	THC120F3	BAYHTRD327*	20.3/27.0	2	81/92	90/100	-/-	-/-
10	THC120F3	BAYHTRZ337*	27.0/36.0	2	104/119	110/125	-/-	-/-
10	THC120F3	BAYHTRZ354*	40.6/54.0	2	151/141	175/175	-/-	-/-
<b>460 Volts Three Phase</b>								
6	THC072*4	BAYHTRA409*	9	1	17	20	19	20
6	THC072*4	BAYHTRA418*	18	1	31	35	32	35
6	THC072*4	BAYHTRA427*	27	2	44	45	46	45
6	THC072*4	BAYHTRA436*	36	2	58	60	60	60
6	THC074F4	BAYHTRA409*	9	1	20	20	—	—
6	THC074F4	BAYHTRA418*	18	1	33	35	—	—
6	THC074F4	BAYHTRA427*	27	2	47	50	—	—
6	THC074F4	BAYHTRA436*	36	2	60	60	—	—
7.5	THC092F4	BAYHTRA409*	9	1	20	25	—	—
7.5	THC092F4	BAYHTRA418*	18	1	33	35	—	—
7.5	THC092F4	BAYHTRA427*	27.0	2	47	50	—	—
7.5	THC092F4	BAYHTRA436*	36.0	2	60	60	—	—
8.5	THC102F4	BAYHTRA409*	9.0	1	21	25	—	—
8.5	THC102F4	BAYHTRA418*	18.0	1	33	35	—	—
8.5	THC102F4	BAYHTRA427*	27.0	2	47	50	—	—
8.5	THC102F4	BAYHTRA436*	36.0	2	60	60	—	—
10	THC120F4	BAYHTRD418*	18.0	1	33	35	—	—
10	THC120F4	BAYHTRD427*	27.0	2	47	50	—	—
10	THC120F4	BAYHTRZ436*	36.0	2	60	60	—	—
10	THC120F4	BAYHTRZ454*	54.0	2	71	90	—	—

<sup>(a)</sup> Heater kW ratings are at 208/240V for 208/230V units, 480V for 460V units.

**Table 167. Electrical characteristics – compressor motor and condenser fan motor – 60 cycle – high efficiency**

Tons	Unit Model Number	No.	Compressor Motors						No.	Condenser Fan Motors				
			Volts	Phase	hp <sup>(a)</sup>	rpm	Amps <sup>(b)</sup>			Volts	Phase	hp	Amps	
							RLA	LRA					FLA	LRA
3	T/YHC036E3	1	208-230	3	2.7	3500	10.4	73	1	208-230	1	0.2	1.5	2.4
3	T/YHC036E4	1	460	3	2.7	3500	5.8	38	1	460	1	0.2	0.6	1.3
3	T/YHC036EW	1	575	3	2.7	3500	3.8	36.5	1	575	1	0.4	0.8	2
4	T/YHC048E_F3	1	208-230	3	3.5	3500	13.7	83.1	1	208-230	1	0.4	2.5	6.6
4	T/YHC048E_F4	1	460	3	3.5	3500	6.2	41	1	460	1	0.4	1	2.8
4	YHC048FW	1	575	3	3.5	3500	4.8	33	1	575	1	0.4	0.8	2
5	T/YHC060E_F3	1	208-230	3	4.3	3500	15.9	110	1	208-230	1	0.4	2.5	6.6
5	T/YHC060E_F4	1	460	3	4.3	3500	7.1	52	1	460	1	0.4	1	2.8
5	YHC060FW	1	575	3	4.1	3500	5.1	40	1	575	1	0.4	0.8	2
6	T/YHC072E/F3	1	208-230	3	4.9	3500	19.2	136	1	208-230	1	0.7	3.3	9.5
6	T/YHC072E/F4	1	460	3	4.9	3500	8.7	66	1	460	1	0.7	1.8	5.5
6	YHC072E/FW	1	575	3	4.8	3500	6.9	55	1	575	1	0.75	2.4	6.2
6	T/YHC074F3	2	208-230	3	5.0/2.3	3500/2900	14.6/7.1	83.0/55.0	1	208-230	1	0.7	3.5	10.9
6	T/YHC074F4	2	460	3	5.0/2.3	3500/2900	6.8/3.5	41.0/28.0	1	460	1	0.7	2.4	6.6
7.5	T/YHC092F3	2	208-230	3	4.1/2.4	3500/3500	15.9/10.0	110.0/71.0	1	208-230	1	0.75	4	9.3
7.5	T/YHC092F4	2	460	3	4.1/2.4	3500/3500	7.1/4.7	52.0/38.0	1	460	1	0.75	2.8	6.2
7.5	YHC092FW	2	575	3	3.8/2.4	3500/3500	5.1/3.7	40.0/28.0	1	575	1	0.75	2.4	6.2
8.5	T/YHC102F3	2	208-230	3	4.5/2.4	3500/3500	15.6/10.0	110.0/71.0	1	208-230	1	0.75	4	9.3

**Table 167. Electrical characteristics – compressor motor and condenser fan motor – 60 cycle – high efficiency (continued)**

Tons	Unit Model Number	No.	Compressor Motors						No.	Condenser Fan Motors				
			Volts	Phase	hp <sup>(a)</sup>	rpm	Amps <sup>(b)</sup>			Volts	Phase	hp	Amps	
							RLA	LRA					FLA	LRA
8.5	T/YHC102F4	2	460	3	4.5/2.4	3500/3500	7.8/4.7	52.0/38.0	1	460	1	0.75	2.8	6.2
8.5	YHC102FW	2	575	3	4.6/2.4	3500/3500	5.8/3.7	39.0/28.0	1	575	1	0.75	2.4	6.2
10	T/YHC120F3	2	208-230	3	5.1/2.9	3500/3500	19.6/13.2	136.0/88.0	1	208-230	3	0.75	2.7	9.8
10	T/YHC120F4	2	460	3	5.1/2.9	3500/3500	8.2/6.0	66.0/44.0	1	460	3	0.75	1.5	4.8
10	YHC120FW	2	575	3	5.1/2.9	3500/3500	6.6/4.2	55.0/30.0	1	575	3	0.75	1.4	4.8

<sup>(a)</sup> hp for each compressor

<sup>(b)</sup> Amp draw for each motor (compressor and standard indoor fan motor); multiply value by number of motors to determine total amps.

**Table 168. Electrical characteristics – evaporator fan motor – 60 cycle – direct drive – high efficiency**

Tons	Unit Model Number	Volts	Hz	Motor Phase	No.	FLA	LRA	bhp
3	T/YHC036E3	208-230	60	1	1	6.0	—	0.75
3	T/YHC036E4	460	60	1	1	3.2	—	0.75
3	YHC036EW	575	60	1	1	3.5	—	0.75
4	T/YHC048E_F3	208-230	60	1	1	6.0	—	0.75
4	T/YHC048E_F4	460	60	1	1	4.0	—	1.00
4	YHC048FW	575	60	1	1	3.5	—	1.00
5	T/YHC060E_F3	208-230	60	1	1	7.6	—	1.00
5	T/YHC060E_F4	460	60	1	1	4.0	—	1.00
5	YHC060FW	575	60	1	1	3.5	—	1.00

**Notes:**

- Belt drive indoor motor is standard equipment on T/YHC036E-T/YHC060E with optional dehumidification.
- Precedent™ 575V rated units utilize a high efficiency 230 evaporator fan motor powered through a 575/230V transformer. Motor voltage/FLA rated at transformer input.

**Table 169. Electrical characteristics – evaporator fan motor – 60 cycle – optional belt drive – high efficiency**

Tons	Unit Model Number	Volts	Hz	Motor Phase	No.	FLA	LRA	bhp
3	T/YHC036E3	208-230	60	3	1	3.4	32.2	1.00
3	T/YHC036E4	460	60	3	1	1.6	16.1	1.00
3	YHC036EW	575	60	3	1	1.7	13.2	1.00
4	T/YHC048E3	208-230	60	3	1	3.4	32.2	1.00
4	T/YHC048E4	460	60	3	1	1.6	16.1	1.00
4	T/YHC048F3	208-230	60	3	1	3.4	32.2	1.00
4	T/YHC048E4	460	60	3	1	1.6	16.1	1.00
4	YHC048FW	575	60	3	1	1.7	13.2	1.00
5	T/YHC060E3	208-230	60	3	1	3.4	32.2	1.00
5	T/YHC060E4	460	60	3	1	1.6	16.1	1.00
5	T/YHC060F3	208-230	60	3	1	3.4	32.2	1.00
5	T/YHC060F4	460	60	3	1	1.6	16.1	1.00
5	YHC060FW	575	60	3	1	1.7	13.2	1.00

**Note:** Belt drive indoor motor is standard equipment on T/YHC036E-T/YHC060E with optional dehumidification.

**Table 170. Electrical characteristics – standard evaporator fan motor – 60 cycle – direct or belt drive – high efficiency**

Tons	Unit Model Number	Direct or Belt Drive	Volts	Hz	Phase	hp	FLA	LRA
6	T/YHC072*3	Belt Drive	208-230	60	3	1	3.4	24.5
6	T/YHC072*4	Belt Drive	460	60	3	1	1.6	12.3



## Electrical Data

**Table 170. Electrical characteristics — standard evaporator fan motor – 60 cycle — direct or belt drive — high efficiency (continued)**

Tons	Unit Model Number	Direct or Belt Drive	Volts	Hz	Phase	hp	FLA	LRA
6	YHC072*W	Belt Drive	575	60	3	1.5	1.7	—
6	T/YHC074F3	Direct Drive	208-230	60	3	2.75	7.3	—
6	T/YHC074F4	Direct Drive	460	60	3	2.75	3.6	—
7.5	T/YHC092F3	Direct Drive	208-230	60	3	2.75	7.3	—
7.5	T/YHC092F4	Direct Drive	460	60	3	2.75	3.6	—
7.5	YHC092FW	Direct Drive	575	60	3	2.75	7.5	—
8.5	T/YHC102F3	Direct Drive	208-230	60	3	2.75	7.3	—
8.5	T/YHC102F4	Direct Drive	460	60	3	2.75	3.6	—
8.5	YHC102FW	Direct Drive	575	60	3	2.75	7.5	—
10	T/YHC120F3	Direct Drive	208-230	60	3	2.75	7.3	—
10	T/YHC120F4	Direct Drive	460	60	3	2.75	3.6	—
10	YHC120FW	Direct Drive	575	60	3	2.75	7.5	—

**Note:** Precedent™ 575V rated units utilize a high efficiency 380-480V evaporator fan motor powered through a 575/480V transformer assembly. Motor voltage/FLA rated at transformer input.

**Table 171. Electrical characteristics — oversize evaporator fan motor – 60 cycle — direct or belt drive — high efficiency**

Tons	Unit Model Number	Direct or Belt Drive	Volts	Hz	Phase	hp	FLA	LRA
6	T/YHC072*3	Belt Drive	208-230	60	3	2	6.3	48.0
6	T/YHC072*4	Belt Drive	460	60	3	2	3.1	24.0
6	YHC072*W	Belt Drive	575	60	3	2	2.5	18.2

**Table 172. Electrical characteristics — inducer motor**

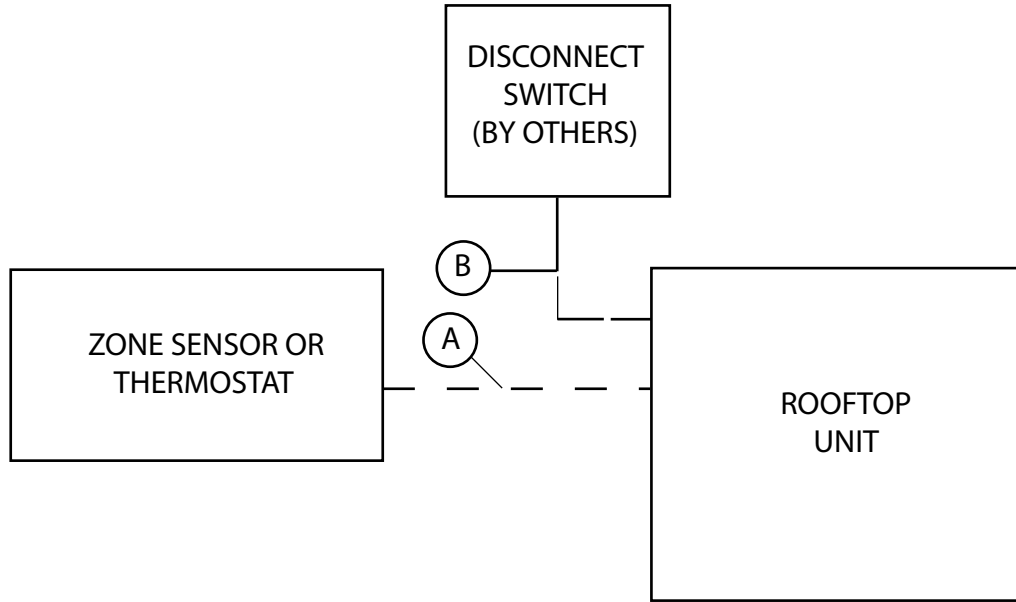
Unit Model Number	Stages	hp	rpm	Volts	Phase	LRA
YHC(048-060)E/F*(L,M,H,X,Y,Z)	1	1/35	3000	208-230	1	0.6
YHC(036)E*(L,M,X,Y)	1	1/35	3000	208-230	1	0.6
YHC(036)E*(H,Z)	1	1/35	3300	208-230	1	0.4
YHC(072,074)**(L,M,X,Y)	1	1/35	3000	208-230	1	0.6
YHC(092,102)**(L,X)	1	1/35	3000	208-230	1	0.6
YHC(072,074)**(H,Z)	2	1/15	3350	208-230	1	0.4
YHC(092-102)**(M,H,Y,Z)	2	1/15	3350	208-230	1	0.4
YHC120	2	1/15	3350	208-230	1	0.4



# Jobsite Connections

Zone Sensors		
A	Manual Changeover	4
	Manual/Auto Changeover	5
	Manual/Auto Changeover with Status Indication LED's	10
	Programmable Night Setback with Status Indication LED's	7
Thermostats		
A	3 Wires, 24V, Cooling only	
	4 Wires 24V, with Electric Heat	
B	3 Power Wires + 1 Ground Wire (3-phase)	
	2 Power Wires + 1 Ground Wire (1-phase)	

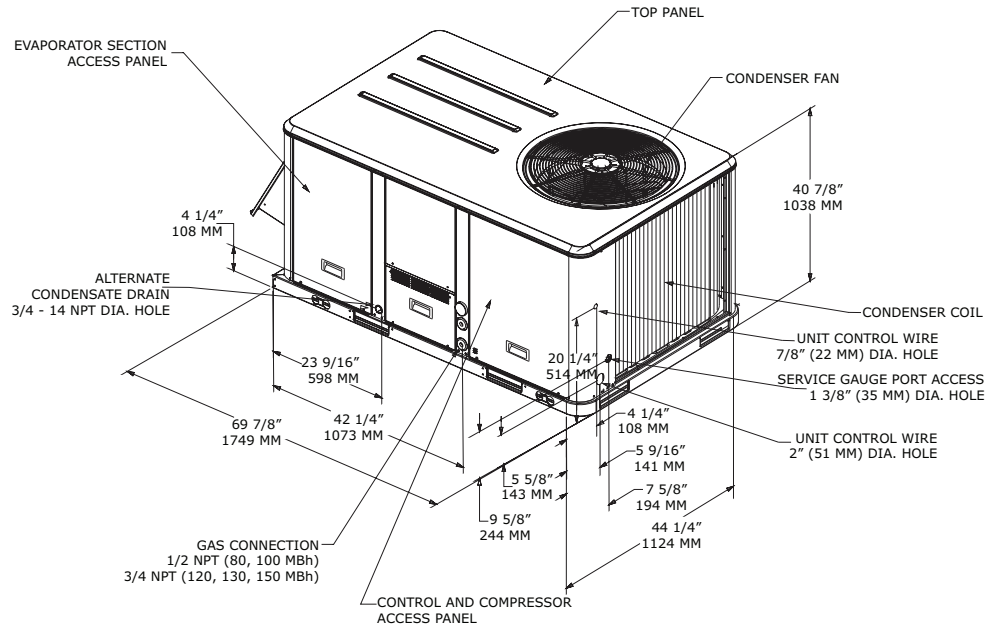
**Note:** For specific wiring information, please see the installation instructions.  
**Note:** All wiring except power wire is low voltage.



**Note:** All customer supplied wiring to be copper and must conform to applicable electrical codes (such as NEC or CEC) and local electric codes. Wiring shown dotted is to be furnished and installed by the customer.

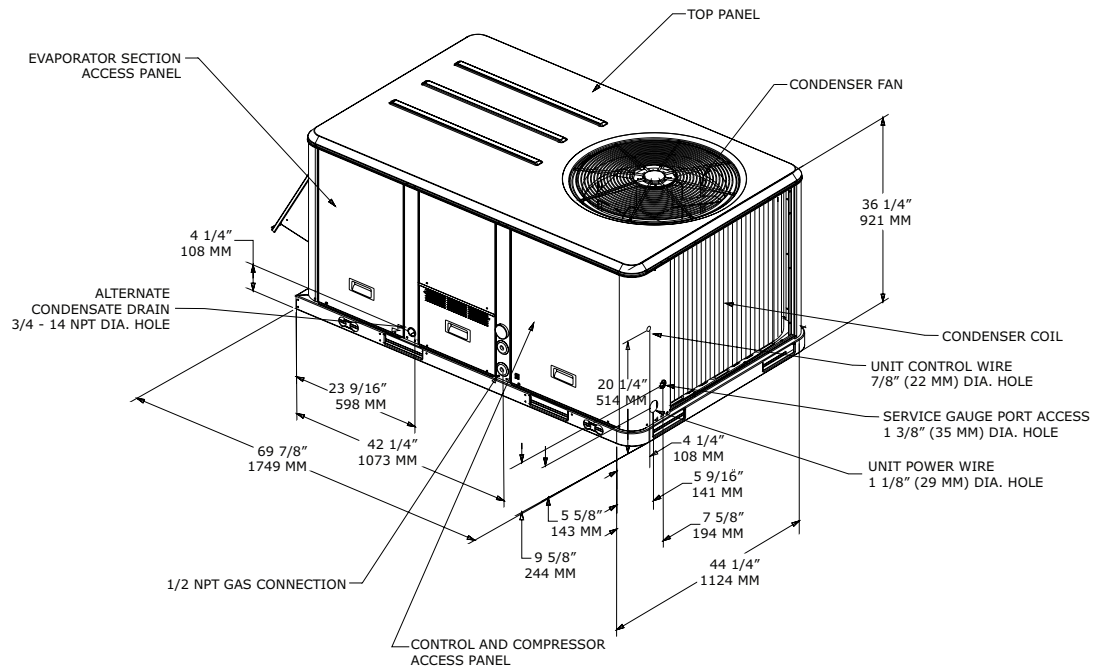
# Dimensional Data

**Figure 4. Cooling and gas/electric – 3 to 5 tons standard efficiency**



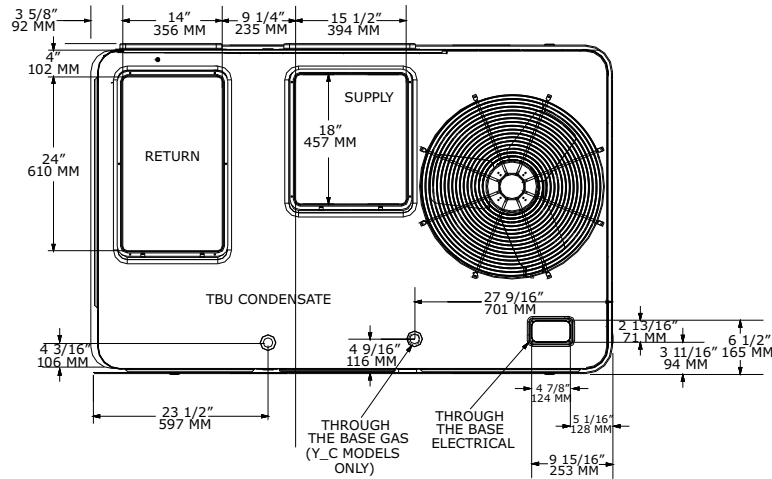
**Note:** 1/2 NPT or 3/4 NPT gas connection = (Y\_C models only); 2" electrical connection: single point power when heat installed (T\_C models only)

**Figure 5. Cooling and gas/electric – 3 tons high efficiency**

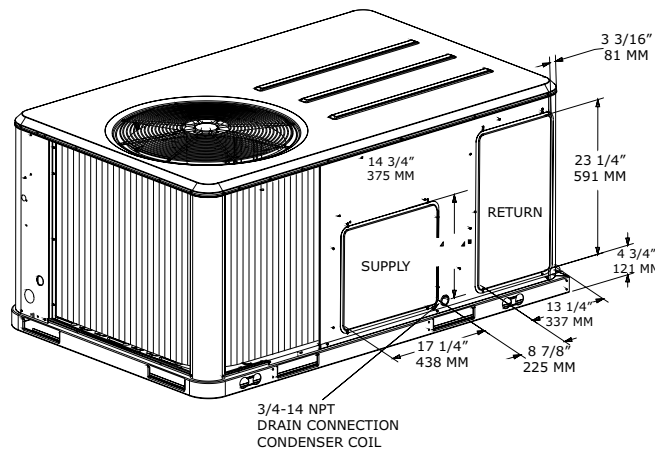


**Note:** 1/2 NPT gas connection = (Y\_C models only); 2" electrical connection: single point power when heat installed (T\_C models only)

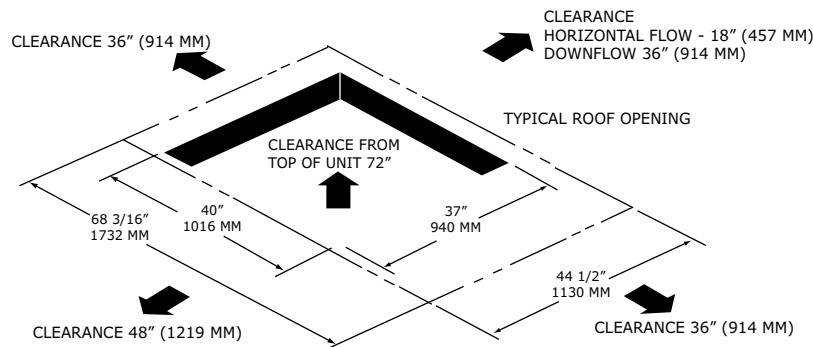
**Figure 6. Cooling and gas/electric — 3 to 5 tons standard efficiency, 3 tons high efficiency downflow airflow supply/return — through-the-base utilities**



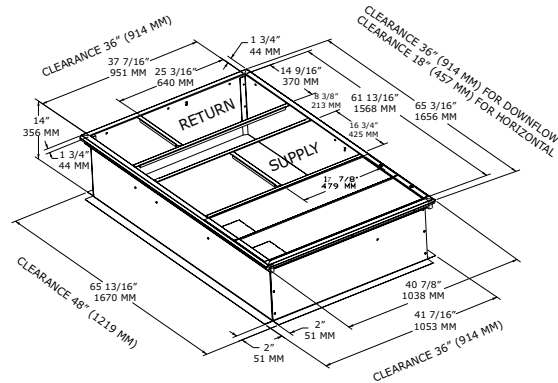
**Figure 7. Cooling and gas/electric — 3 to 5 tons standard efficiency, 3 tons high efficiency — horizontal airflow supply/return**



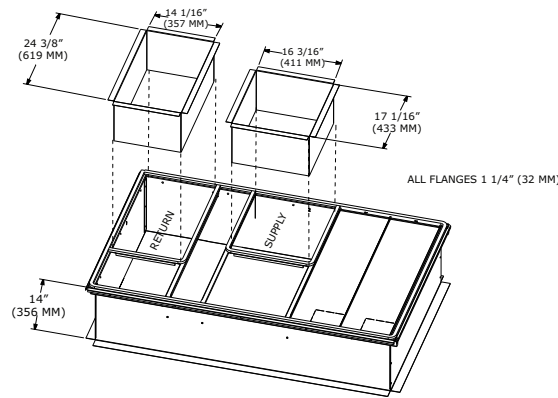
**Figure 8. Cooling and gas/electric — 3 to 5 tons standard efficiency, 3 tons high efficiency — unit clearance and roof opening**



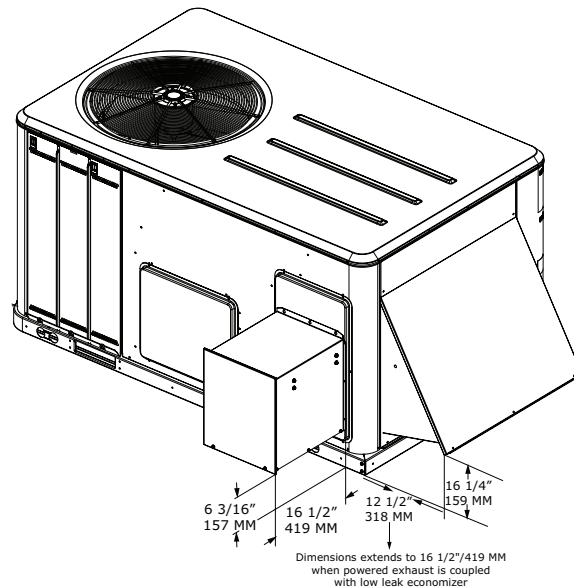
**Figure 9. Cooling and gas/electric – 3 to 5 tons standard efficiency, 3 tons high efficiency – roof curb**



**Figure 10. Cooling and gas/electric – 3 to 5 standard efficiency, 3 tons high efficiency – downflow duct connections, field fabricated**

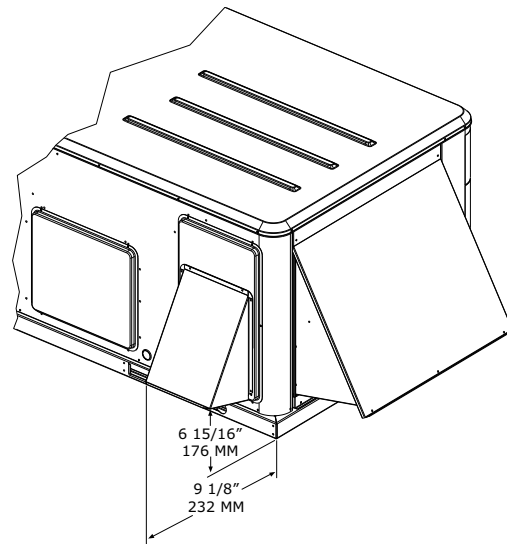


**Figure 11. Cooling and gas/electric – 3 to 5 tons standard efficiency, 3 tons high efficiency – economizer, manual or motorized fresh air damper, power exhaust**

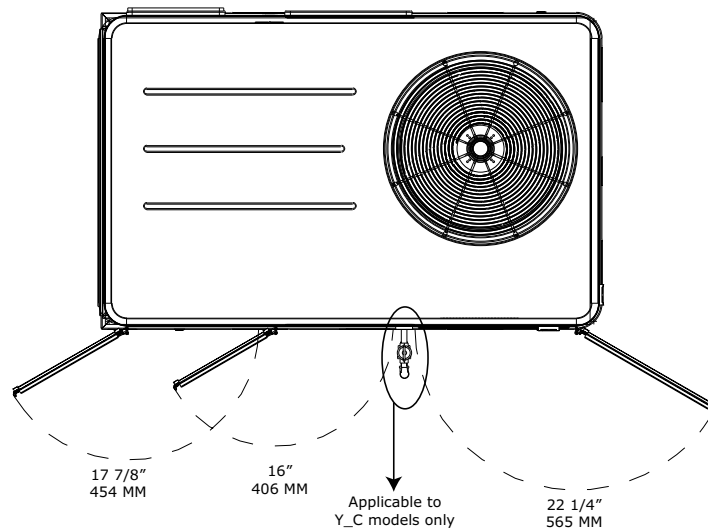




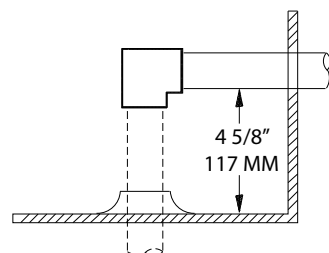
**Figure 12. Cooling and gas/electric — 3 to 5 tons standard efficiency, 3 tons high efficiency — economizer & barometric relief damper hood**



**Figure 13. Cooling and gas/electric — 3 to 5 tons standard efficiency, 3 tons high efficiency — swing diameter for hinged door(s) option**

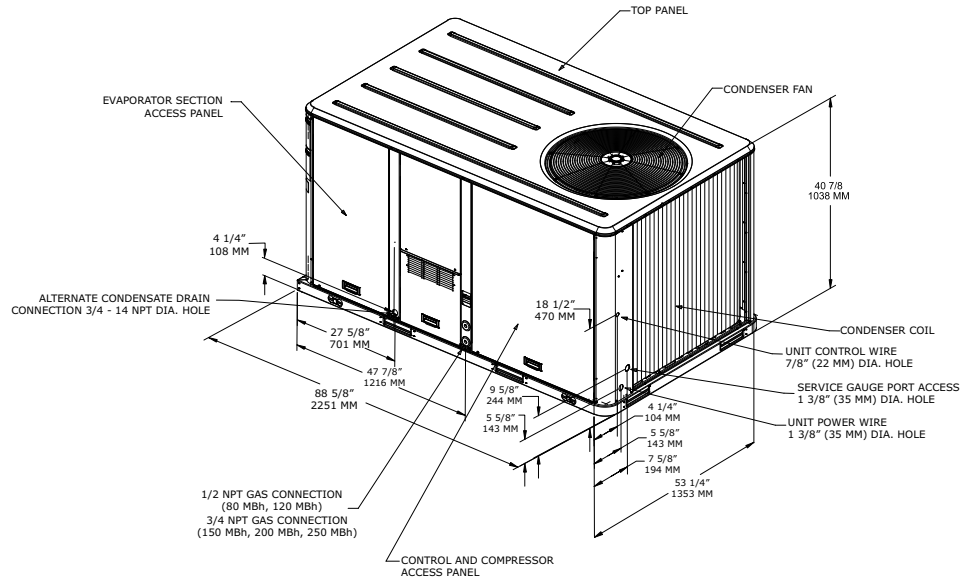


**Figure 14. Gas/electric — 3 to 10 tons standard and high efficiency — gas pipe height (Y models only)**

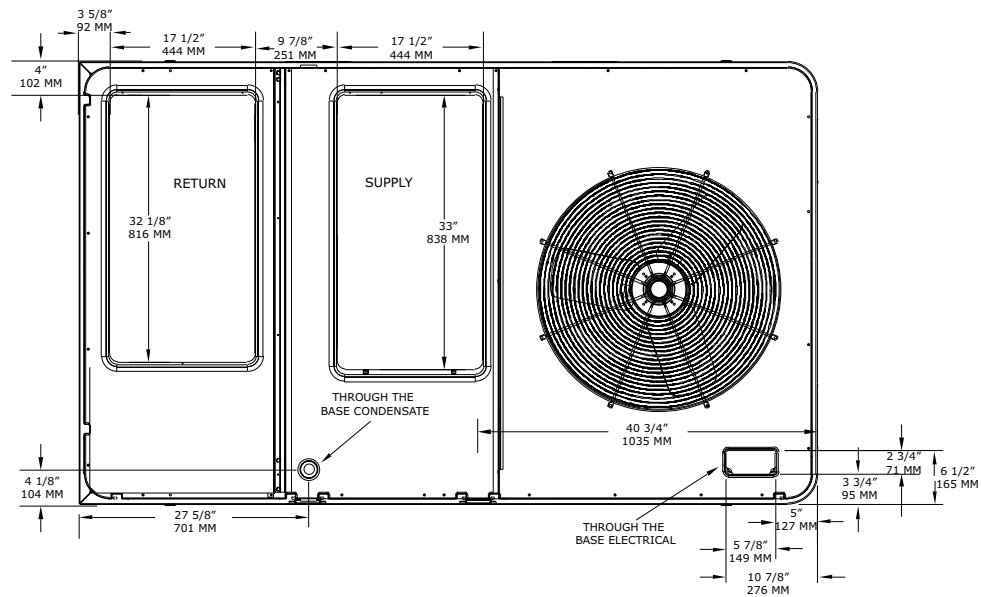


**Note:** Height of gas pipe required from inside unit base to gas shut off assembly (factory provided)

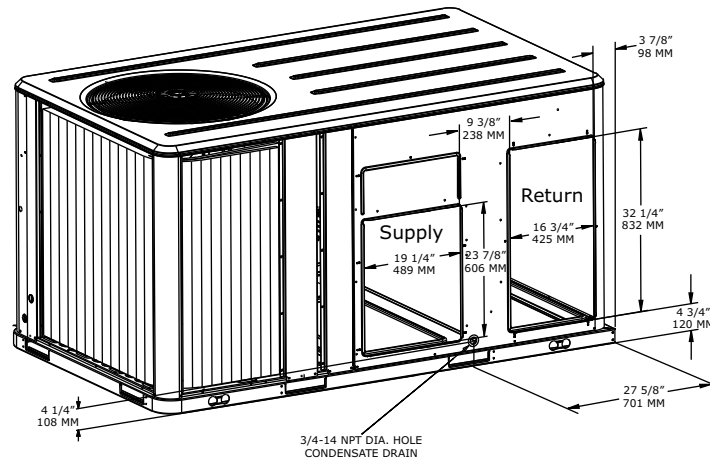
**Figure 15. Cooling and gas/electric — 6, 7.5 (single) tons standard efficiency, 4 to 5 tons high efficiency**



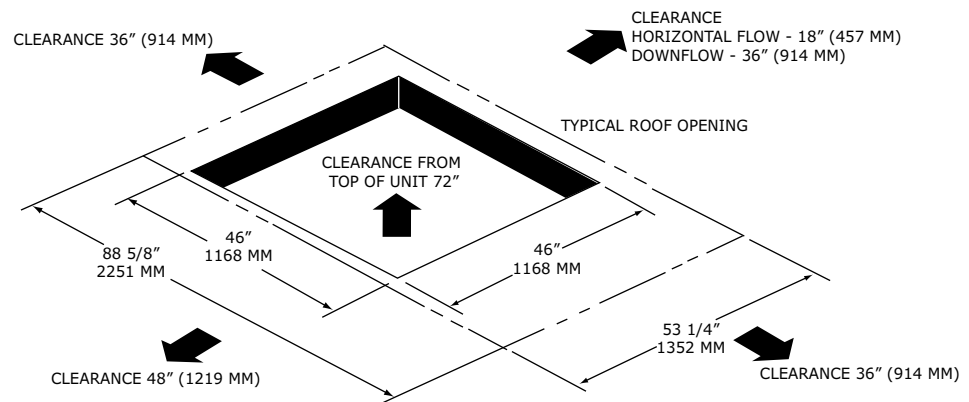
**Figure 16. Cooling and gas/electric — 6 to 10 tons standard efficiency, 4 to 8.5 tons high efficiency — downflow airflow supply/return, through-the-base utilities**



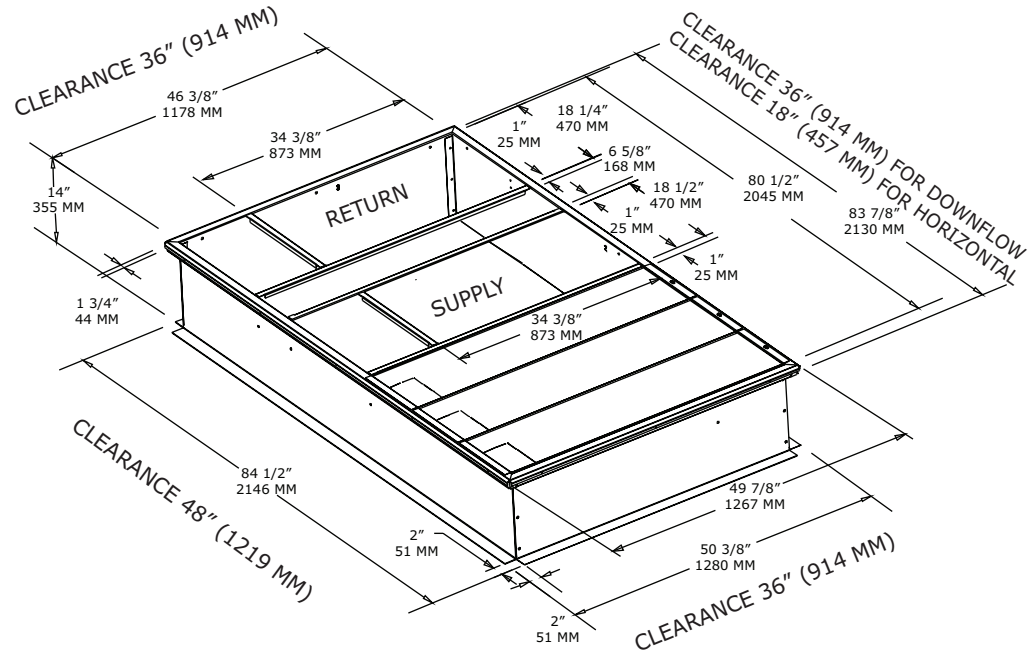
**Figure 17. Cooling and gas/electric – 6, 7.5 (single) tons standard efficiency, 4 to 5 tons high efficiency – horizontal airflow, supply and return**



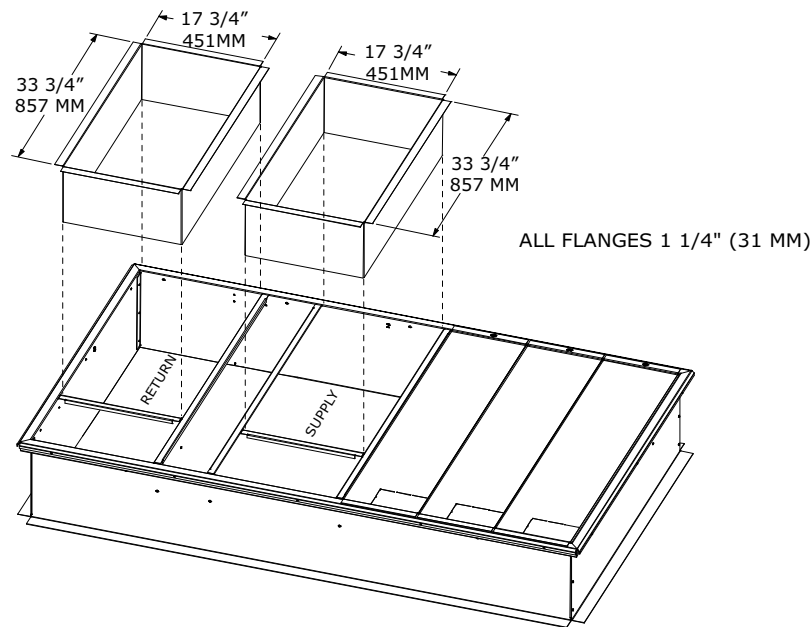
**Figure 18. Cooling and gas/electric – 6 to 10 tons standard efficiency, 4 to 8.5 tons high efficiency – unit clearance and roof opening**



**Figure 19. Cooling and gas/electric — 6 to 10 tons standard efficiency, 4 to 8.5 tons high efficiency — roof curb**



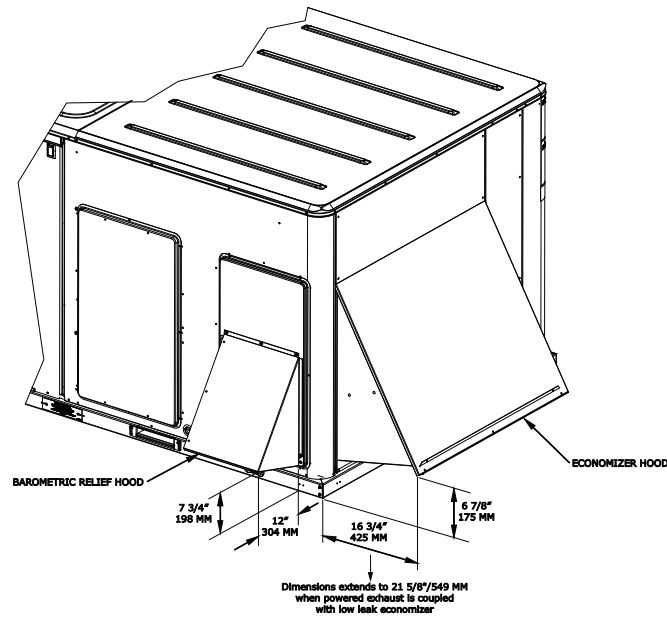
**Figure 20. Cooling and gas/electric — 6 to 10 tons standard efficiency, 4 to 10 tons high efficiency — downflow duct connections, field fabricated**



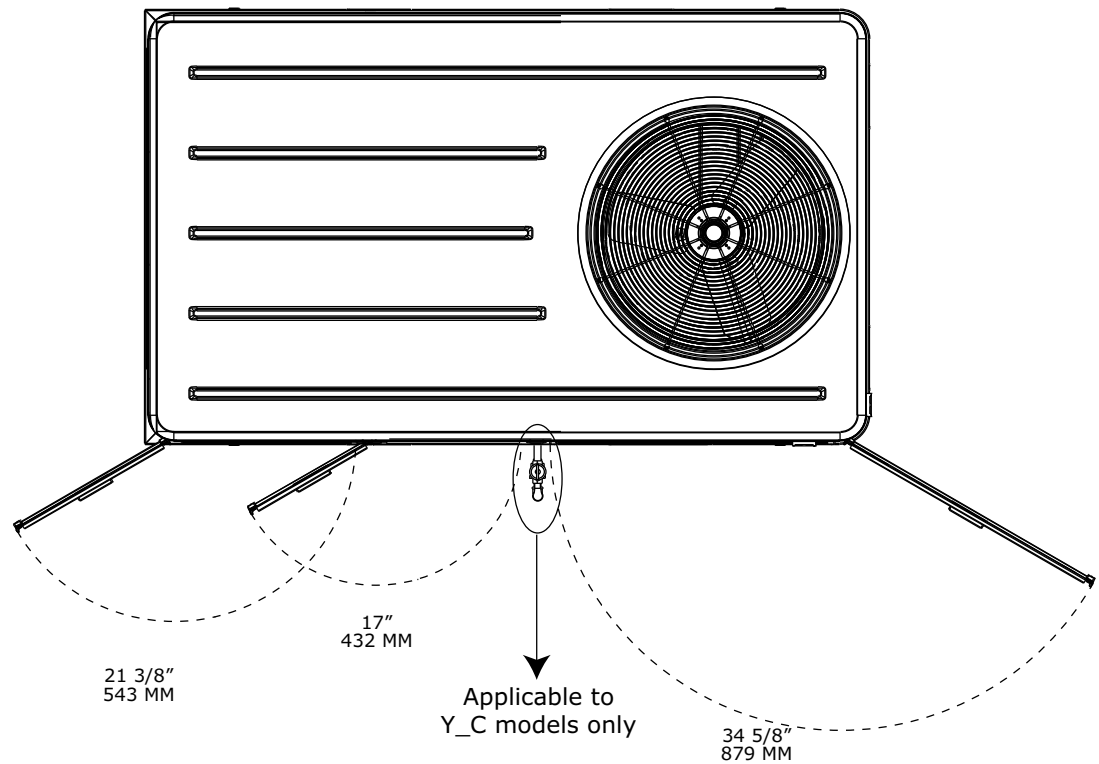
**Notes:**

- 1/2 or 3/4 NPT gas connection = (Y\_C models only); 2" electrical connection: single point power when heat installed (T\_C models only)
- Reference tabular information for duct clearance to combustible materials in the application consideration chapter

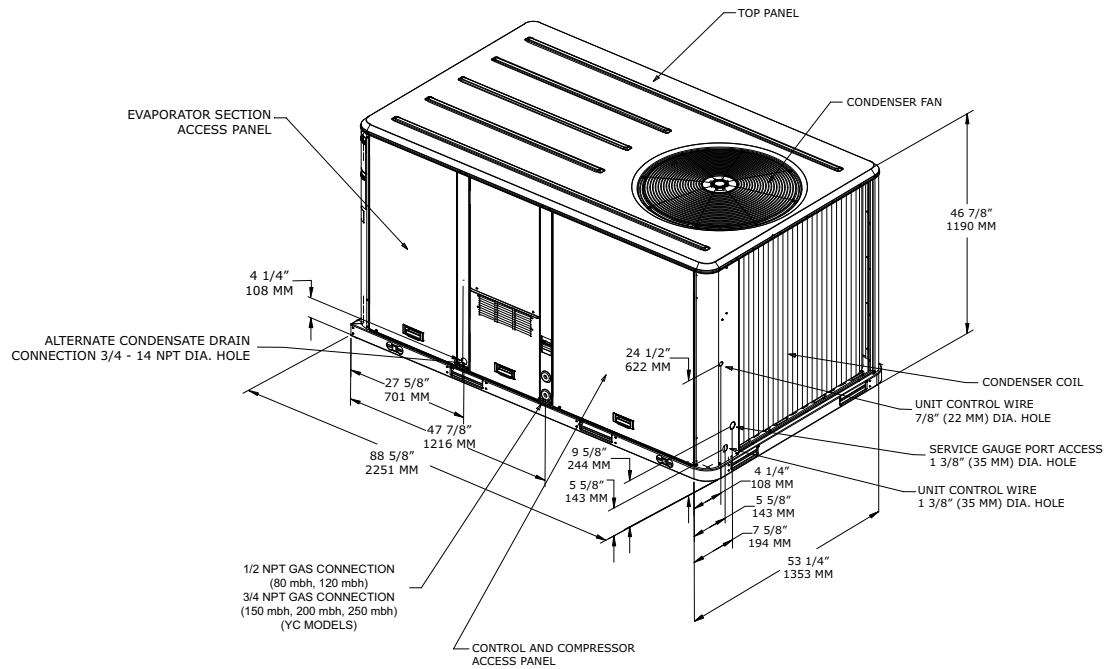
**Figure 21. Cooling and gas/electric — 6 to 10 tons standard efficiency, 4 to 10 tons high efficiency — economizer, manual or motorized fresh air damper**



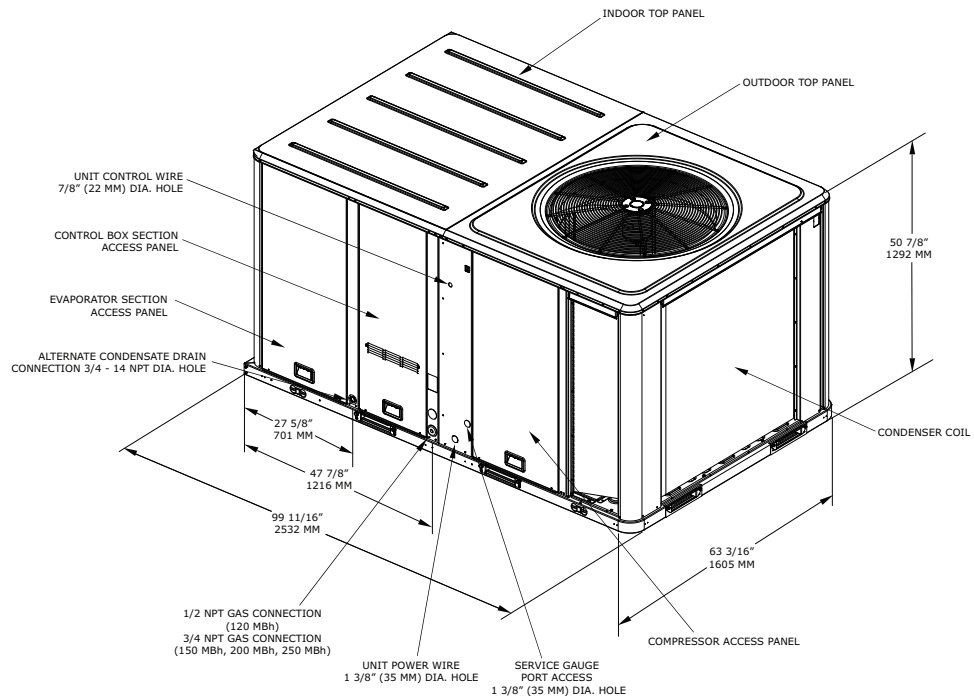
**Figure 22. Cooling and gas/electric — 6 to 10 tons standard efficiency, 4 to 8.5 tons high efficiency — swing diameter for hinged door(s) option**



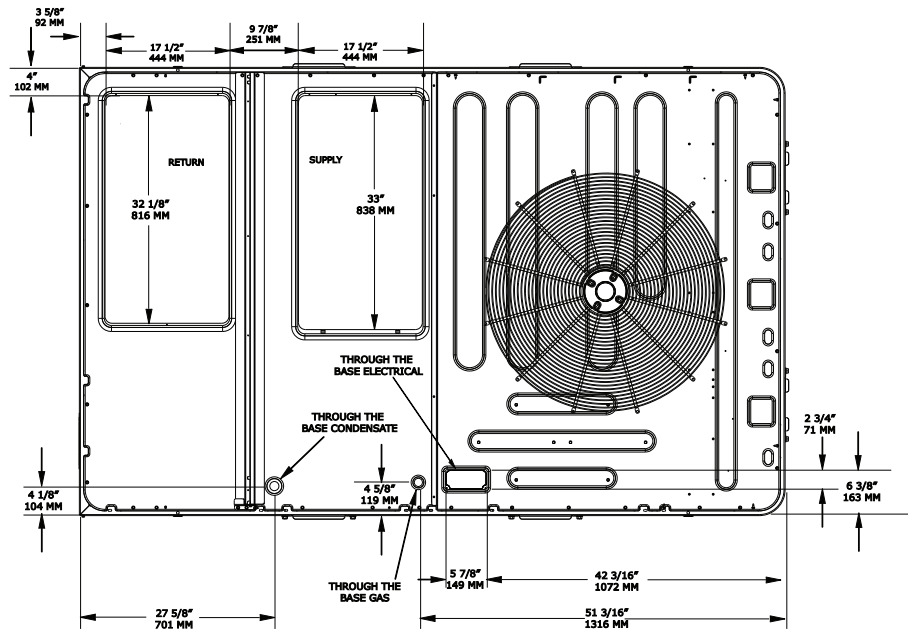
**Figure 23. Cooling and gas/electric — 7.5 (dual compressor) to 10 tons standard efficiency, 6 to 8.5 tons high efficiency**



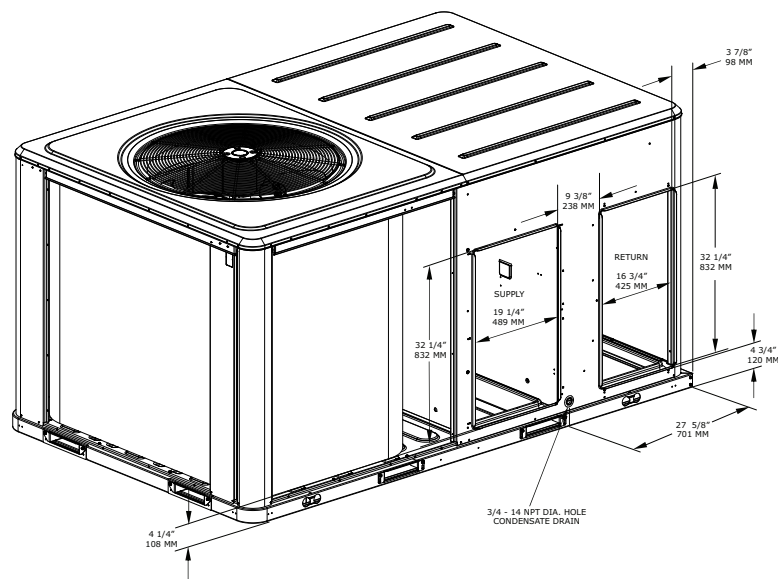
**Figure 24. Cooling and gas/electric — 10 tons high efficiency**



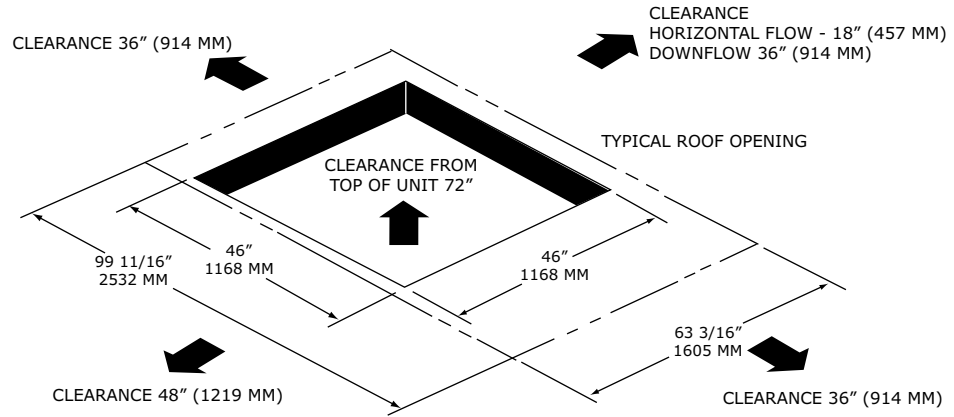
**Figure 25. Cooling and gas/electric – 10 tons high efficiency – downflow airflow supply/ return, through-the-base utilities**



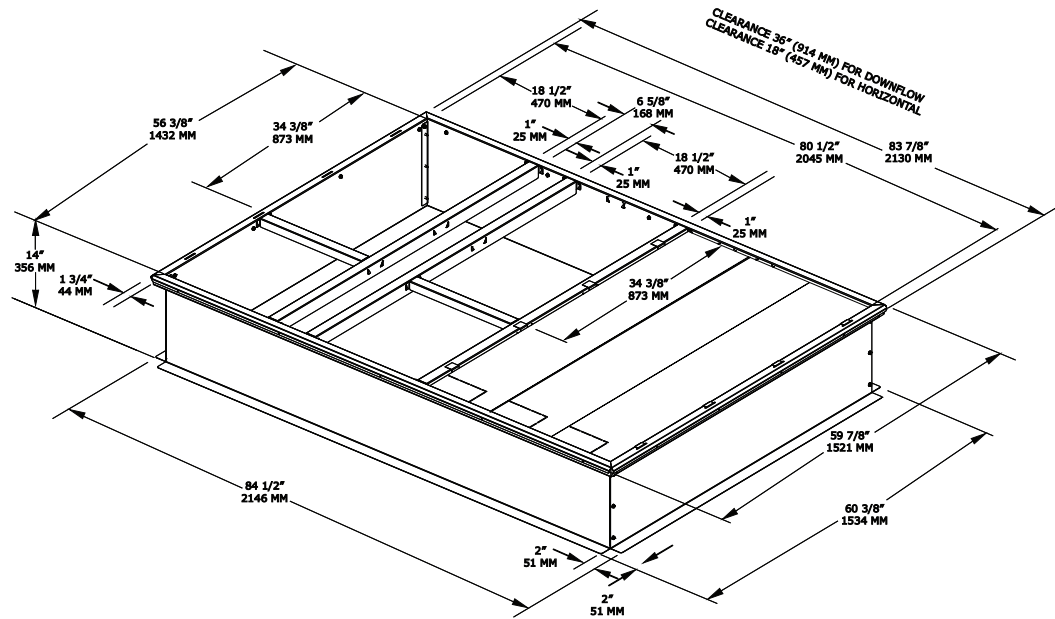
**Figure 26. Cooling and gas/electric – 10 tons high efficiency – horizontal airflow, supply and return**



**Figure 27. Cooling and gas/electric – 10 tons high efficiency – unit clearance and roof opening**

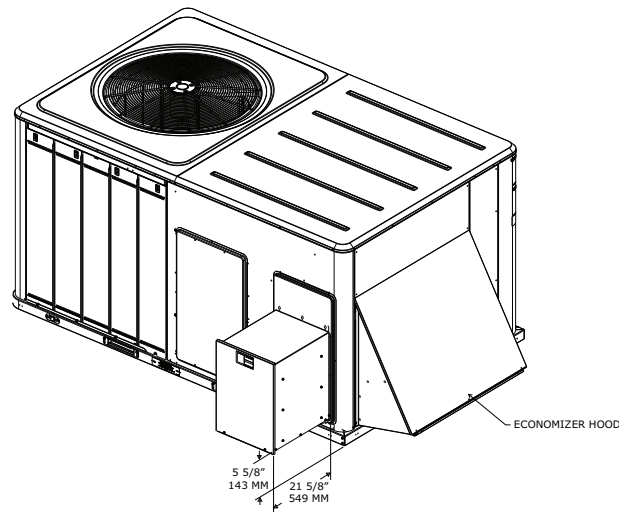


**Figure 28. Cooling and gas/electric – 10 tons high efficiency – roof curb**

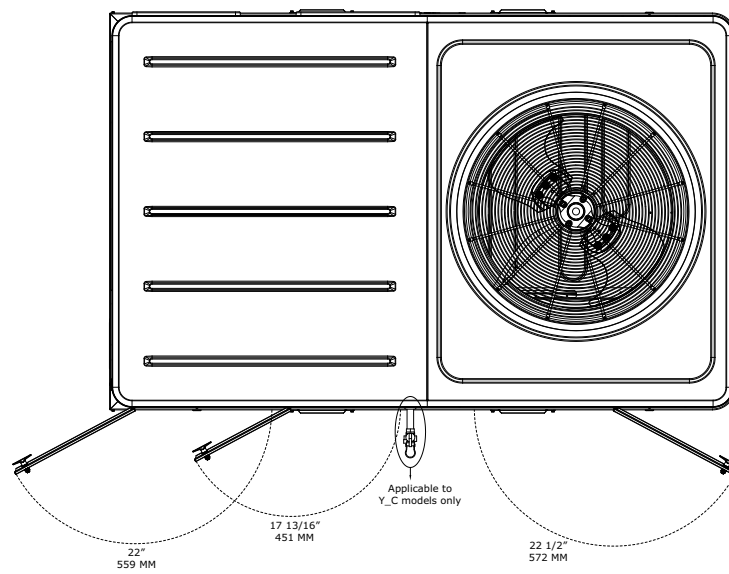




**Figure 29. Cooling and gas/electric — 6 to 10 tons— power exhaust**



**Figure 30. Cooling and gas/electric — 10 tons high efficiency — swing diameter for hinged door(s) option**



# Weights

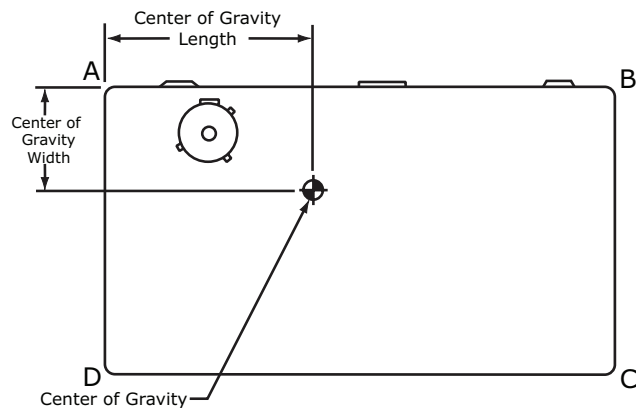
**Table 173. Maximum unit & corner weights (lbs) and center of gravity dimensions (in.) – cooling models**

Tons	Unit Model No.	Maximum Model Weights <sup>(a)</sup>		Corner Weights <sup>(b)</sup>				Center of Gravity (in.)	
		Shipping	Net	A	B	C	D	Length	Width
3	TSC036G	537	431	201	155	25	50	29	8
4	TSC048G	557	452	213	159	27	53	29	8
5	TSC060G	603	498	218	140	50	90	27	12
6	TSC072H	762	667	218	186	131	132	44	21
7.5	TSC090H	844	751	233	205	148	165	42	22
7.5	TSC092H	940	797	249	235	163	149	46	21
8.5	TSC102H	980	879	288	230	191	170	47	22
10	TSC120H	1058	960	320	218	233	189	40	24
3	THC036E	555	481	157	122	95	107	31	19
4	THC048E	787	692	220	178	132	163	40	23
4	THC048F	737	642	208	177	128	130	44	22
5	THC060E	841	746	241	193	139	173	39	22
5	THC060F	774	679	219	189	135	137	43	21
6	THC072E	943	845	274	172	186	213	41	24
6	THC072F	883	740	228	219	155	138	47	21
6	THC074F	1016	918	309	207	223	178	40	24
7.5	THC092F	1026	928	315	209	224	180	40	24
8.5	THC102F	1035	937	316	212	227	181	49	24
10	THC120F	1326	1132	326	326	258	222	53	27

<sup>(a)</sup> Weights are approximate.

<sup>(b)</sup> Corner weights are given for information only.

**Figure 31. Corner weights**



**Table 174. Maximum unit & corner weights (lbs) and center of gravity dimensions (in.) – gas/electric models**

Tons	Unit Model No.	Maximum Model Weights <sup>(a)</sup>		Corner Weights <sup>(b)</sup>				Center of Gravity (in.)	
		Shipping	Net	A	B	C	D	Length	Width
3	YSC036G	577	472	193	178	45	55	33	9
4	YSC048G	598	492	205	183	46	58	33	9
5	YSC060G	627	522	214	193	52	63	33	10
6	YSC072H	805	710	222	217	121	150	41	22
7.5	YSC090H	925	832	253	225	169	185	42	23
7.5	YSC092H	990	847	265	249	173	160	46	21
8.5	YSC102H	1028	927	300	242	203	182	47	22
10	YSC120H	1156	1058	345	242	258	213	41	23

**Table 174. Maximum unit & corner weights (lbs) and center of gravity dimensions (in.) – gas/electric models (continued)**

Tons	Unit Model No.	Maximum Model Weights <sup>(a)</sup>		Corner Weights <sup>(b)</sup>				Center of Gravity (in.)	
		Shipping	Net	A	B	C	D	Length	Width
3	YHC036E	607	532	165	137	95	134	31	19
4	YHC048E	858	763	238	200	148	176	40	23
4	YHC048F	806	711	226	199	144	143	44	22
5	YHC060E	917	822	261	218	156	187	40	22
5	YHC060F	850	755	239	214	152	151	44	21
6	YHC072E	1025	927	296	198	205	228	41	24
6	YHC072F	965	822	250	245	174	153	47	21
6	YHC074F	1114	1016	334	231	248	202	41	23
7.5	YHC092F	1124	1026	340	233	249	204	41	23
8.5	YHC102F	1133	1035	341	236	253	205	49	23
10	YHC120F	1453	1259	356	371	289	242	54	27

<sup>(a)</sup> Weights are approximate.

<sup>(b)</sup> Corner weights are given for information only.

**Table 175. Factory installed options (fiops)/accessory net weights (lbs)**

Accessory	T/YSC036G-060G	T/YHC048E-060E	T/YSC072H-102H	T/YSC120H	T/YHC120F
	T/YHC036E Net Weight	T/YHC048F-060F Net Weight	T/YHC072E/F Net Weight	T/YHC074F-102F Net Weight	Net Weight
	3 to 5 Tons	4 to 5 Tons	6 to 8.5 Tons	6,7.5,8.5,10 Tons	10 Tons
Barometric Relief	7	10	10	10	10
Belt Drive Option (3 phase only)	31	31	—	—	—
Coil Guards	12	20	20	20	30
Economizer	26	36	36	36	36
Electric Heaters <sup>(a)</sup>	15	30	30	44	50
Hinged Doors	10	12	12	12	12
Low Leak Economizer	70	91	91	91	91
Manual Outside Air Damper	16	26	26	26	26
Motorized Outside Air Damper	20	30	30	30	30
Novar Control	8	8	8	8	8
Oversized Motor	5	8	8	—	—
Powered Convenience Outlet	38	38	38	38	50
Powered Exhaust	40	40	80	80	80
Reheat Coil	12 <sup>(b)</sup>	14	15	20 <sup>(c)</sup>	30
Roof Curb	61	78	78	78	89
Smoke Detector, Supply	5	5	5	5	5
Smoke Detector, Return	7	7	7	7	7
Stainless Steel Heat Exchanger <sup>(d)</sup>	4	6	6	6	6
Through-the-Base Electrical	8	13	13	13	13
Through-the-Base Gas	5	5	5	5	5
Traq Dampers	10	15	15	15	15
Unit Mounted Circuit Breaker	5	5	5	5	5
Unit Mounted Disconnect	5	5	5	5	5

**Notes:**

- Weights for options not listed are <5 lbs.
- Net weight should be added to unit weight when ordering factory-installed accessories.

<sup>(a)</sup> Applicable to cooling units only.

<sup>(b)</sup> Reheat weight here is only applicable to T/YHC036E models.

<sup>(c)</sup> Reheat weight for this value only applicable to 7.5 and 8.5 Tons high efficiency "F" models.

<sup>(d)</sup> Applicable to gas/electric units only.



# Mechanical Specifications

## Standard

### General

- Packaged rooftop units cooling, heating capacities, and efficiencies are AHRI Certified within scope of AHRI Standard 210-240 for 3 to 5 tons units or 340-360 (I-P) for 6 to 10 tons units and ANSIZ21.47 and 10 CFR Part 431 pertaining to Commercial Warm Air Furnaces (all gas heating units)
- Convertible airflow
- Microprocessor controls operating range between 115°F and 0°F in cooling mode standard from the factory
- Electromechanical controls operating range between 115°F and 40°F
- Factory assembled, internally wired, fully charged with R-410A, and 100 percent run tested to check cooling operation, fan and blower rotation, and control sequence before leaving the factory
- Colored and numbered wiring internal to the unit for simplified identification
- Units cULus listed and labeled, classified in accordance for Central Cooling Air Conditioners

### Casing

- Zinc coated, heavy gauge, galvanized steel
- Weather-resistant baked enamel finish on phosphatized exterior surfaces
- Meets ASTM B117, 672 hour salt spray test
- Removable single side maintenance access panels
- Lifting handles in maintenance access panels (can be removed and reinstalled by removing two fasteners while providing a water and air tight seal)
- Exposed vertical panels and top covers in the indoor air section insulated with a cleanable foil-faced, fire-retardant permanent, odorless glass fiber material
- Base pan shall have no penetrations within the perimeter of the curb other than the raised 1 1/8 inch high downflow supply/return openings to provide an added water integrity precaution, if the condensate drain backs up
- Base of the unit insulated with 1/8 inch, foil-faced, captured and sealed, closed-cell insulation
- Unit base provisions for forklift and/or crane lifting on three sides of unit

### Coils

#### Evaporator and Condenser

- Internally finned, 5/16 inch copper tubes mechanically bonded to a configured aluminum plate fin
- Evaporator coils standard for all 3 to 10 tons standard efficiency models
- Coils leak tested to 600 psig
- Assembled unit leak tested to 465 psig
- Condenser coil — patent pending 1+1+1 hybrid coil designed with slight gaps for ease of cleaning
- Standard plastic, dual-sloped, removable and reversible condensate drain pan with through-the-base condensate drain

#### Microchannel Condenser

- Standard for 3 to 10 tons standard efficiency models and 4,5,6, 7.5, 8.5 tons high efficiency models
- Not offered on the 4 and 5 tons dehumidification models
- Optimal heat transfer performance due to flat, streamlined tubes with small ports, and metallurgical tube-to-fin bond
- Reduce system refrigerant charge by up to 50% leading to better compressor reliability
- Compact all-aluminum microchannel coils reduce the unit weight
- Recyclable all aluminum coils All aluminium construction minimizes galvanic corrosion

- Strong aluminum brazed structure provides better fin protection
- Flat streamlined tubes more dust resistant and easy to clean
- Coils leak tested at the factory to ensure the pressure integrity

## Compressors

- All units have direct-drive, hermetic, scroll type compressors with centrifugal type oil pumps
- Suction gas-cooled motor with voltage utilization range of plus or minus 10 percent of unit nameplate voltage
- Internal overloads standard with scroll compressors
- Crankcase heaters optional on 3 to 10 tons standard efficiency units and standard on 3 to 10 tons high efficiency units
- Dual compressors recommended for humidity control, light load cooling conditions and system back-up applications
- Three stages of cooling available on 6 to 10 tons high efficiency units with dual compressors

## Controls

- Units factory-wired with necessary controls and contactor pressure lugs or terminal block for power wiring
- External location available for mounting a fused disconnect device
- Choice of electromechanical or microprocessor controls

### Electromechanical

- 24-volt control circuit shall include control transformer and contactor pressure lugs for power wiring
- Units shall have single point power entry as standard

### Microprocessor

- 24V control functions
- Resident control algorithms shall make all heating, cooling, and/or ventilating decisions in response to electronic signals from sensors measuring indoor and outdoor temperatures
- Control algorithm maintains accurate temperature control, minimizes drift from set point, and provides better building comfort
- Anti-short cycle timing and time delay between compressors provide a higher level of machine protection

## Filters

- Standard throwaway filters
- Optional 2-inch MERV 8 and MERV 13 filters

## Gas Heating Section

- Progressive tubular heat exchanger, stainless steel burners and corrosion resistant steel
- Induced draft combustion blower shall be used to pull the combustion products through the firing tubes
- Heater shall use a direct spark ignition (DSI) system
- On initial call for heat, the combustion blower shall purge the heat exchanger for 20 seconds before ignition
- After three unsuccessful ignition attempts, entire heating system shall be locked out until manually reset at the thermostat/zone sensor
- Units shall be suitable for use with natural gas or propane (field-installed kit)
- (3 to 5 tons only) For installation in SCAQMD only: This furnace does not meet the SCAQMD Rule 1111 14 ng/J NO<sub>x</sub> emission limit, and thus is subject to a mitigation fee of up to \$450. This furnace is not eligible for the Clean Air Furnace Rebate Program: [www.cleanairfurnacerebate.com](http://www.cleanairfurnacerebate.com)



## Mechanical Specifications

---

### Indoor Fan

- Direct drive plenum fan design – 10 tons, 6 ton (074), 7.5 to 8.5 tons high efficiency units, and optional on 7.5 tons (092) to 8.5 tons standard efficiency units
- Plenum fan design – backward-curved fan wheel along with an external rotor direct drive variable speed indoor motor
- Plenum fan design – variable speed adjustment potentiometer located in the control box
- Belt drive units – 3 to 5 tons units (high efficiency 3-phase with optional motor) and 6 to 8.5 tons, standard efficiency
- Multispeed, direct drive motors – FC centrifugal fans with adjustable motor sheaves. 3 to 5 tons units (standard and high efficiency)
- Motors thermally protected.
- Variable speed direct drive motors – 10 tons, 6 ton (074), 7.5 to 8.5 (high efficiency)
- Indoor fan motors meet the U.S. Energy Policy Act of 1992 (EPACT)

### Outdoor Fan

- Direct-drive, statically balanced, draw-through in the vertical discharge position
- Permanently lubricated, built-in thermal overload protection included

### Phase Monitoring Protection

- 3-phase power equipped with phase monitoring protection as standard
- Protect motors and compressors against problems caused by phase loss, phase imbalance and phase reversal indication

### Refrigerant Circuits

- Thermal expansion valve standard
- Service pressure ports, and refrigerant line filter driers factory-installed standard
- Area provided for replacement suction line driers

### Unit Top

- One piece construction or where seams exist, it shall be outside the indoor air-conditioned section
- Ribbed top adds extra strength and prevents water from pooling

## Factory Installed Options

### Black Epoxy Pre-Coated Coils

- Thermoset vinyl coating
- Bonded to aluminum fin stock (prior to the fin-stamping process)
- Economical option for protection in mildly corrosive environments

**Note:** *Not available on microchannel condenser coils*

### CO<sub>2</sub> Sensor Wiring

- Factory-installed CO<sub>2</sub> sensor wiring saves time and ensures proper unit connections for field installed CO<sub>2</sub> sensor kits

### CompleteCoat™ Coils

- Cathodic epoxy type electro-disposition coating formulated for high edge build to plate fin and tube heat exchangers
- Coating provides excellent resistance and durability to corrosive effects of alkalies, acids, alcohols, petroleum, seawater, salt air and corrosive environments
- Option is available for the plate fin-tube condenser coil and the microchannel type condenser coil

## Condensate Overflow Switch

- If a clogged condensate drain line is preventing proper condensate removal from the unit this option will shut the unit down

## Heat Exchanger

- Compact cabinet features a tubular heat exchanger in low, medium and high heat capacities
- Corrosion-resistant aluminized steel tubes and burners are standard on all models
- Induced draft blower to pull the gas mixture through the burner tubes
- Direct spark ignition system doubles as a safety device to validate the flame

## Hinged Access Doors

- Sheet metal hinges available on the filter/evaporator, supply fan/heat, and the compressor/control access doors

## Human Interface

- 5 inch color touchscreen display that conforms to FCC Part 15 Class B with an Ingress Protection Rating of IP24
- Display text shall be readable by a person with 20/20 vision at a distance of 3 feet and 60° angle at lighting levels ranging from 100 lux - 25,000 lux
- Display shall operate at temperatures of -40° C to 70° C
- Firmware and unit configurations shall be able to be restored via a USB storage device

## Fault Detection & Diagnostics (FDD)

- Meets the mandatory requirement of CA Title 24 of fully configured diagnostics allowing fault history and reading fault codes at the unit
- Provides detection of the following faults: Air temperature sensor failure/fault and notification of acceptable economizer mode
- FDD system shall be certified by the Energy Commission as meeting the requirements

## Novar Return Air Sensor

- When used in conjunction with Novar Controls, this option contains a factory provided and wired zone temperature sensor located in the return air stream

## Novar Controls

- Shall be installed and tested
- Electronic thermostat module will interface to the unit microprocessor and control the unit to the desired stage of cooling or heating

## Powered or Unpowered Convenience Outlet

- Powered or unpowered GFCI, 120V/15amp, 2 plug, convenience outlet
- When convenience outlet is powered, a service receptacle disconnect will be available
- Convenience outlet is powered from the line side of the disconnect or circuit breaker, and therefore will not be affected by the position of the disconnect or circuit breaker
- Available to order when through-the-base electrical with disconnect switch or circuit breaker option is ordered

## Multi-Speed Indoor Fan System

- Automatically switch operation of the indoor fan between high speed and low speed, based on the number of compressors operating
- Operate at high speed whenever the gas or electric heater is operating

## Multi-Zone VAV Control

- To maintain the duct static pressure at a setpoint, control shall vary the speed of the indoor fan



## Mechanical Specifications

---

- Cooling mode — compressors shall cycle (or economizer shall modulate) to maintain supply air temperature (SAT) at desired setpoint
- Heating mode — indoor fan shall operate at maximum speed when heater is operating
- VAV units cannot be controlled by a thermostat

### Single Zone VAV – One Zone Variable Air Volume Mode

- As zone cooling or heating load changes, indoor fan speed will vary
- Cooling capacity is cycled to maintain the supply air temperature at setpoint
- Indoor fan shall operate at maximum speed whenever heater operating

**Notes:**

- *Requires the use of a zone temperature sensor*
- *If a unit is configured for SZVAV, but connected to a conventional thermostat, the unit will revert to multiple-speed (two-speed) indoor fan control*

### Stainless Steel Drain Pan

- Corrosion and oxidation resistance
- Reversible and constructed of 304 stainless steel

### Stainless Steel Heat Exchanger

- Constructed of 409 stainless steel tubes and 439 stainless steel burners
- Resistant to corrosion and oxidation and easy to clean
- High strength to weight ratio allows for high ventilation rates with gas units
- Compliment dehumidification option as a high outside air ventilation unit
- 10-year stainless steel heat exchanger warranty is standard.

### Supply, Return and Plenum Air Smoke Detector

- All unit operation will shut down if smoke is detected
- Reset manual at unit
- In order for supply or return air smoke detector to properly sense smoke in the supply/return air stream, entering air velocity must be between 500 - 4000 feet per minute
- Equipment covered in this manual will develop an airflow velocity that falls within these limits over the entire airflow range specified in the evaporator fan performance table
- Supply and/or return smoke detectors may not be used with plenum smoke detector

### Through-the-Base Electrical Access

- Electrical access for control and main power connections inside the curb and through-the-base of the unit
- Field installation of liquid-tight conduit
- External field-installed disconnect switch

### Through-the-Base Electrical with Circuit Breaker

- Thermal magnetic, molded case, HACR circuit breaker with provisions for through-the-base electrical connections
- Circuit breaker installed within unit in water tight enclosure
- Access through a swinging door
- Wiring provided from the switch to the unit high voltage terminal block
- Circuit breaker will provide overcurrent protection, sized per NEC and cULus guidelines, and agency recognized by cULus

### Through-the-Base Electrical with Disconnect Switch

- 3-pole, molded case, disconnect switch with provisions for through-the-base electrical connections
- Disconnect switch installed within unit in a water tight enclosure
- Access through a swinging door



- Wiring provided from the switch to the unit high voltage terminal block
- Switch cULus agency recognized

**Note:** Disconnect switch sized per NEC and cULus guidelines but will not be used in place of unit overcurrent protection

### **Through-the-Base Gas Piping**

- Unit shall include a standard through-the-base gas provision
- All necessary piping including, black steel, manual gas shut-off valve, elbows, and union
- Manual shut-off valve shall include a 1/8" NPT pressure tap
- Assembly will require minor field labor to install (gas/electric only)

### **Two-Inch Filters**

- Two-inch MERV 8 and MERV 13 media filters available on all models

## **Factory or Field Installed Options**

### **Clogged Filter/Fan Failure Switch**

- Dedicated differential pressure switch available to achieve active fan failure indication and/or clogged filter indication
- Registered with either a zone sensor with status indication lights or an Integrated Comfort System
- Available for microprocessor controlled units

### **Discharge Air Temperature Sensing**

- Provides true discharge air temperature sensing in heating models.
- Readable through Tracer® or Tracker™.
- Functional only with the ReliaTel™ options module.

### **Economizer (Standard)**

- Available with or without barometric relief.
- Fully modulating 0-100 percent motor and dampers, minimum position setting, preset linkage, wiring harness with plug, spring return actuator and fixed dry bulb control
- Barometric relief shall provide a pressure operated damper that shall be gravity closing
- Barometric relief shall prohibit entrance of outside air during the equipment "off" cycle
- Optional solid state or differential enthalpy control
- Arrives in shipping position and shall be moved to the operating position by the installing contractor

### **Electric Heaters**

- Constructed of heavy-duty nickel chromium elements internally delta connected for 240V, wye connected for 480V and 600V
- Staging achieved through ReliaTel™
- Automatically reset high limit control operating through heating element contactors
- Heaters individually fused from the factory
- Shall meet all NEC and CEC requirements when properly installed
- Power assemblies shall provide single-point connection
- Modules shall be cULus listed

### **Frostat™**

- Utilized as a safety device



## Mechanical Specifications

---

- Opens when temperatures on evaporator coil fall below 10°F
- Temperature will need to rise to 50°F before closing
- Utilized in low airflow or high outside air applications (cooling only)

### Low Leak Economizer

- Meets low leak requirements for ASHRAE 90.1, IECC, and CA Title 24 standards (4 cfm/ft<sup>2</sup>@1" wg exterior air/return air)
- 100% outdoor air supply from 0-100% modulating dampers
- Standard with barometric relief
- Can be paired with powered exhaust for additional building pressure relief
- Can be paired with or without Fault Detection & Diagnostics (FDD) to meet current mandatory CA Title 24 requirements
- Available on downflow units only
- Economizers come with three control options, dry bulb and reference or comparative enthalpy (optional)

### Reference or Comparative Enthalpy

- Reference enthalpy used to measure and communicate outdoor humidity
- Unit receives and uses information to provide improved comfort cooling while using the economizer
- Comparative enthalpy measures and communicates humidity for both outdoor and return air conditions, and return air temperature
- Unit receives and uses information to maximize use of economizer cooling, and to provide maximum occupant comfort control
- Reference or comparative enthalpy available when a factory or field installed downflow economizer ordered
- Option is available on all downflow models

### Hail Guards

- Available for condenser coil protection

## Field Installed Options

### CO<sub>2</sub> Sensor

- Ability to monitor the concentration (parts per million, ppm) of CO<sub>2</sub> (Carbon Dioxide) in the air.
- As CO<sub>2</sub> concentration changes, outside air damper modulates to meet the current ventilation needs of the zone
- Two field installed kits are offered; CO<sub>2</sub> sensor and wiring or CO<sub>2</sub> sensor only
- CO<sub>2</sub> sensor only kit should be ordered with factory installed CO<sub>2</sub> sensor wiring

### High Static Drive

- High static drive shall allow the standard motor to operate with improved external static capabilities

### Low Leak Economizer

- Meets low leak requirements for ASHRAE 90.1, IECC, and CA Title 24 standards (4 cfm/ft<sup>2</sup>@1" wg exterior air/return air)
- 100% outdoor air supply from 0-100% modulating dampers
- Standard with barometric relief

- Can be paired with powered exhaust for additional building pressure relief
- Available on downflow units only

**Manual Outside Air Damper**

- Rain hood and screen shall provide up to 50 percent outside air

**Motorized Outside Air Damper**

- Once set, when indoor fan starts, outdoor air dampers shall open to set position
- When indoor fan shuts down, damper shall close to the full closed position

**Outside Air Measuring/Monitoring (Traq Dampers)**

- Requires Low Leak Economizer (Factory or Field Installed)
- Includes:
  - UC400 Controller
  - Damper Actuator
  - Pressure Sensors

**Powered Exhaust**

- Available for 3 to 10 ton units
- Shall provide exhaust of return air, when using an economizer
- Maintain better building pressurization

**Roof Curb**

- Designed to mate with the unit's downflow supply and return
- Provide support and a water tight installation when installed properly
- Shall allow field-fabricated rectangular supply/return ductwork to be connected directly to the curb
- Curb shall be shipped knocked down for field assembly
- Shall include wood nailer strips

**Ventilation Override Accessory**

- Unit can be set to transition up to 3 different pre-programmed sequences for smoke purge, pressurization, and exhaust
- Transition occurs when binary input on the RTOM is closed (shorted) (typically hard wired relay output from a smoke detector/ fire control panel)



The AHRI Certified mark indicates Trane U.S. Inc. participation in the AHRI Certification program. For verification of individual certified products, go to [ahridirectory.org](http://ahridirectory.org).

Trane - by Trane Technologies (NYSE: TT), a global innovator - creates comfortable, energy efficient indoor environments for commercial and residential applications. For more information, please visit [trane.com](http://trane.com) or [tranetechnologies.com](http://tranetechnologies.com).

Trane has a policy of continuous product and product data improvements and reserves the right to change design and specifications without notice. We are committed to using environmentally conscious print practices.