

Installation, Operation, and Maintenance

Packaged Rooftop Air

Conditioners Foundation™

Cooling and Gas/Electric

15 to 25 Tons, 60 Hz

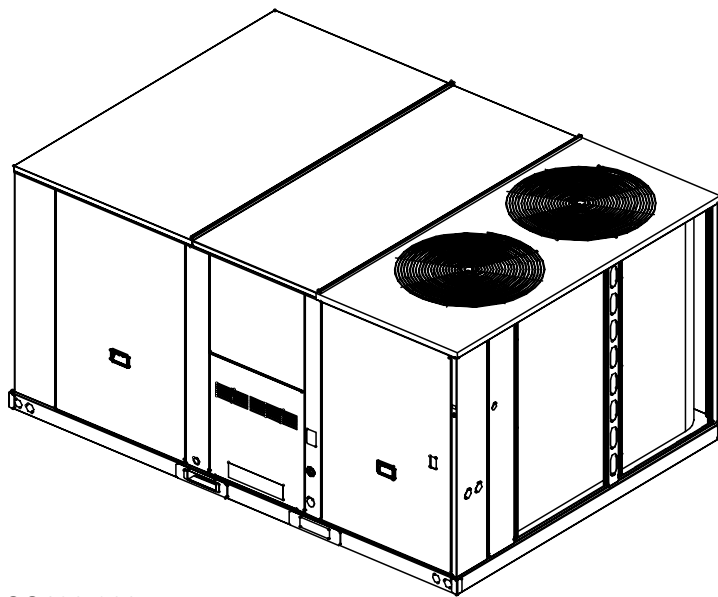

Model Numbers: GCC180-300

▲ SAFETY WARNING

Only qualified personnel should install and service the equipment. The installation, starting up, and servicing of heating, ventilating, and air-conditioning equipment can be hazardous and requires specific knowledge and training. Improperly installed, adjusted or altered equipment by an unqualified person could result in death or serious injury. When working on the equipment, observe all precautions in the literature and on the tags, stickers, and labels that are attached to the equipment.

December 2022

RT-SVX51L-EN

Introduction

Read this manual thoroughly before operating or servicing this unit.

Warnings, Cautions, and Notices

Safety advisories appear throughout this manual as required. Your personal safety and the proper operation of this machine depend upon the strict observance of these precautions.

The three types of advisories are defined as follows:



Indicates a potentially hazardous situation which, if not avoided, could result in death or serious injury.



Indicates a potentially hazardous situation which, if not avoided, could result in minor or moderate injury. It could also be used to alert against unsafe practices.

NOTICE

Indicates a situation that could result in equipment or property-damage only accidents.

Important Environmental Concerns

Scientific research has shown that certain man-made chemicals can affect the earth's naturally occurring stratospheric ozone layer when released to the atmosphere. In particular, several of the identified chemicals that may affect the ozone layer are refrigerants that contain Chlorine, Fluorine and Carbon (CFCs) and those containing Hydrogen, Chlorine, Fluorine and Carbon (HCFCs). Not all refrigerants containing these compounds have the same potential impact to the environment. Trane advocates the responsible handling of all refrigerants-including industry replacements for CFCs and HCFCs such as saturated or unsaturated HFCs and HCFCs.

Important Responsible Refrigerant Practices

Trane believes that responsible refrigerant practices are important to the environment, our customers, and the air conditioning industry. All technicians who handle refrigerants must be certified according to local rules. For the USA, the Federal Clean Air Act (Section 608) sets forth the requirements for handling, reclaiming, recovering and recycling of certain refrigerants and the equipment that is used in these service procedures. In addition, some states or municipalities may have additional requirements that must also be adhered to for responsible management of refrigerants. Know the applicable laws and follow them.

WARNING

Proper Field Wiring and Grounding Required!

Failure to follow code could result in death or serious injury.

All field wiring MUST be performed by qualified personnel. Improperly installed and grounded field wiring poses FIRE and ELECTROCUTION hazards. To avoid these hazards, you MUST follow requirements for field wiring installation and grounding as described in NEC and your local/state/national electrical codes.

WARNING

Personal Protective Equipment (PPE) Required!

Failure to wear proper PPE for the job being undertaken could result in death or serious injury.

Technicians, in order to protect themselves from potential electrical, mechanical, and chemical hazards, **MUST** follow precautions in this manual and on the tags, stickers, and labels, as well as the instructions below:

- **Before installing/servicing this unit, technicians MUST put on all PPE required for the work being undertaken (Examples; cut resistant gloves/sleeves, butyl gloves, safety glasses, hard hat/bump cap, fall protection, electrical PPE and arc flash clothing). ALWAYS refer to appropriate Safety Data Sheets (SDS) and OSHA guidelines for proper PPE.**
- **When working with or around hazardous chemicals, ALWAYS refer to the appropriate SDS and OSHA/GHS (Global Harmonized System of Classification and Labelling of Chemicals) guidelines for information on allowable personal exposure levels, proper respiratory protection and handling instructions.**
- **If there is a risk of energized electrical contact, arc, or flash, technicians MUST put on all PPE in accordance with OSHA, NFPA 70E, or other country-specific requirements for arc flash protection, PRIOR to servicing the unit. NEVER PERFORM ANY SWITCHING, DISCONNECTING, OR VOLTAGE TESTING WITHOUT PROPER ELECTRICAL PPE AND ARC FLASH CLOTHING. ENSURE ELECTRICAL METERS AND EQUIPMENT ARE PROPERLY RATED FOR INTENDED VOLTAGE.**

⚠ WARNING**Follow EHS Policies!**

Failure to follow instructions below could result in death or serious injury.

- All Trane personnel must follow the company's Environmental, Health and Safety (EHS) policies when performing work such as hot work, electrical, fall protection, lockout/tagout, refrigerant handling, etc. Where local regulations are more stringent than these policies, those regulations supersede these policies.
- Non-Trane personnel should always follow local regulations.

NOTICE**Water Damage!**

Failure to follow instructions below could result in equipment and property damage.

Non-factory penetrations through the base of this unit are not allowed. Any penetration in the base of the unit may affect the water tight integrity of the unit and lead to water leaks into the conditioned space.

Overview of Manual

One copy of this document ships inside the control panel of each unit and is customer property. It must be retained by the unit's maintenance personnel.

Important: *Do not release refrigerant to the atmosphere! If adding or removing refrigerant is required, the service technician must comply with all federal, state, and local laws.*

This booklet describes the proper installation, startup, operation, and maintenance procedures for air cooled systems.

By carefully reviewing the information within this manual and following the instructions, the risk of improper operation and/or component damage will be minimized.

It is important that periodic maintenance be performed to help assure trouble free operation. A maintenance schedule is provided at the end of this manual. Should equipment failure occur, contact a qualified service organization with qualified, experienced HVAC technicians to properly diagnose and repair this equipment.

Copyright

This document and the information in it are the property of Trane, and may not be used or reproduced in whole or in part without written permission. Trane reserves the right to revise this publication at any time, and to make changes to its content without obligation to notify any person of such revision or change.

Trademarks

All trademarks referenced in this document are the trademarks of their respective owners.

Factory Training

Factory training is available through Trane University™ to help you learn more about the operation and maintenance of your equipment. To learn about available training opportunities contact Trane University™.

Online: www.trane.com/traneuniversity

Phone: 855-803-3563

Email: traneuniversity@trane.com

Revision History

- New section added in Installation chapter: Gas Heater Conversion Instructions.
- Updated Model Number Description chapter.
- Updated Phase Monitor section in the General Information chapter.
- Updated Weights chapter.
- Updated Gas Heat Data section in the Installation chapter.
- Updated Through the Base Gas Utility section in the Installation chapter.
- Removed 10 Horoscope Motor Overload section in the Start Up chapter.
- Updated Phase Monitor section in the Start Up chapter.
- Updated JADE Controls - Low Leak Economizer Sequence of Operation section in the Start Up chapter.
- Updated Compressor Start-Up section in the Start Up chapter.
- Updated Wiring Diagrams chapter.

Table of Contents

Model Number Description	6	Unit Disconnect (FIYUDC)	28
General Information	7	Through the Base Gas Utility Option.....	29
Unit Inspection	7	Field Installed Connections.....	29
Exterior Inspection	7	Pre Start	31
Inspection for Concealed Damage.....	7	Verifying Proper Air Flow (Units with Belt	
Unit Storage	7	Drive Indoor Fan).....	31
Unit Description	7	Electromechanical Controls – Test	
Economizer Control Actuator		Procedure	31
Electromechanical Control	8	Start Up	32
JADE Economizer Control - Low Leak		Electromechanical Controls - Sequence Of	
Economizer (LLE) Only	8	Operation.....	32
System Input Devices and		Cooling without an Economizer	32
Functions	8	Evaporator Fan Operation (for Gas	
Sensors	8	Units) - Standard Economizer.....	32
Initiation of Operating Modes - JADE		Evaporator Fan Operation (for Cooling	
Controller	9	Only Units) - Standard	
Dimensional Data.....	10	Economizer	32
Weights	16	Economizer Set-Up - Standard	
Rigging.....	17	Economizer	32
Installation	18	Cooling with an Economizer - Standard	
Unit Foundation	18	Economizer	32
Horizontal Units.....	18	Heating Operation (Units with Electric	
Ductwork	18	Heat) - Standard Economizer	32
General Unit Requirements	18	Heating Operation (for Gas Units) -	
Factory Installed Economizer	19	Standard Economizer.....	33
Main Electrical Power		Ignition Module Low, Medium and High	
Requirements	19	Heat	33
External Vent Hood Installation.....	19	Drain Pan Condensate Overflow Switch	
TCO1 Instructions.....	20	(Optional)	33
Gas Heater Conversion		Low Ambient Operation (Optional).....	33
Instructions	20	Two-Speed Indoor Fan Control	33
Condensate Drain Configuration	23	Cooling Operation.....	33
Filter Installation	23	Economizer Minimum Position	
Field Installed MERV13 Filters	23	Handling for 2-Speed Fan.....	34
Field Installed Power Wiring	23	Phase Monitor	34
Main Unit Power.....	24	Low Pressure Cutout	34
Standard Wiring	24	High Pressure Cutout and Temperature	
Optional TBUE Wiring (Through the		Discharge Limit	34
Base Electrical Option)	24	Locking Safety Device with	
Control Power Transformer.....	24	Compressor Anti Short Cycle	
Controls using 24 Vac	24	Timer.....	34
Requirements of Gas Heat	25	Coil Frost Protection.....	34
Gas Heat Data.....	26	Heating Operation.....	34
Voltage Imbalance	27	Emergency Stop	34
Electrical Phasing (Three Phase		JADE Controls - Low Leak Economizer	
Motors).....	27	Sequence of Operation	35
Compressor Crankcase Heaters	28	Economizer Set-Up	36
Checklist.....	28	Drain Pan Condensate Overflow Switch	
Factory-Mounted Unit Options.....	28	(Optional)	36
		Low Ambient Operation (Optional).....	36
		Two-Speed Indoor Fan Control.....	36

Phase Monitor	37	Standard Troubleshooting	44
Low Pressure Cutout	37	Ignition Module	44
High Pressure Cutout and Temperature		Failures	44
Discharge Limit	37	Low Leak Economizer – (LLE)	
Coil Frost Protection	37	Troubleshooting	44
Initiation of Operating Modes	37	Resetting Cooling and Heating	
Standard Economizer Start-Up	37	Lockouts	45
LLE Controls Test Procedure	37	Method 1	45
Compressor Start-Up	38	Method 2	45
Heating Start-Up	38	Condensate Overflow Switch	45
Final System Set Up	38	Unit Economizer Control (ECA)	45
Maintenance	39	Error Code	46
Fan Belt Adjustment-Belt Drive Units	39	Wiring Diagrams	47
Monthly Maintenance	40	Warranty	48
Filters	40	For Commercial Unitary Equipment Rated	
Condensate Overflow Switch	40	25 Tons and Under and Related	
Cooling Season	40	Accessories	48
Heating Season	41	Basic Warranty	48
Coil Cleaning	41	Exclusions and Limitations	48
Troubleshooting	44		

Model Number Description

Digit 1 — Unit Type

G = Packaged Gas/Electric

Digit 2 — Efficiency

C = Generation C

Digit 3 — Airflow Configuration

C = Convertible

Digit 4, 5, 6 — Nominal Gross Cooling Capacity (MBh)

180 = 15 Tons

210 = 17.5 Tons

240 = 20 Tons

300 = 25 Tons

Digit 7 — Major Design Sequence

A = Rev A

Digit 8 — Voltage Selection

3 = 208-230/60/3

4 = 460/60/3

W = 575/60/3

Digit 9 — Unit Controls

E = Electromechanical

Digit 10 — Heating Capacity

H = Gas Heat - High

L = Gas Heat - Low

M = Gas Heat - Medium

X = Gas Heat - SS Ht Ex - Low

Y = Gas Heat - SS Ht Ex - Medium

Z = Gas Heat - SS Ht Ex - High

Digit 11— Minor Design Sequence

Digit 12,13 — Service Sequence

00 = None

Digit 14 — Fresh Air Selection^{3, 4}

0 = No Fresh Air

A = Manual Outside Air Damper 0-25%

B = Motorized Outside Air Damper 0-50%

C = Economizer, Dry Bulb 0-100% without Barometric Relief

D = Economizer, Dry Bulb 0-100% with Barometric Relief¹

E = Economizer, Reference Enthalpy 0-100% without Barometric Relief

F = Economizer, Reference Enthalpy 0-100% with Barometric Relief¹

G = Economizer, Comparative Enthalpy 0-100% without Barometric Relief

H = Economizer, Comparative Enthalpy 0-100% with Barometric Relief¹

J = Downflow Low Leak Economizer, Dry Bulb w/o Barometric Relief

L = Downflow Low Leak Economizer, Reference Enthalpy w/o Barometric Relief

N = Downflow Low Leak Economizer, Comparative Enthalpy w/o Barometric Relief

Digit 15 — Supply Fan/Drive Type/Motor

7 = Multi-Speed Standard Motor

9 = Multi-Speed Oversized Motor

Digit 16 — Access

0 = Standard Fork Access

F = Third Side Condenser Fork Access (15-25 Ton)

Digit 17 — Condenser Coil Protection

0 = Standard Coil

4 = CompleteCoat™ Condenser Coil

Digit 18 — Through The Base Provisions

0 = No Through The Base Provisions

A = Through The Base Electric

B = Through The Base Gas¹

C = Through The Base Electric/Gas

Digit 19 — Disconnect Switch

0 = No Disconnect

1 = Unit Mounted Non-Fused Disconnect Switch²

Digit 20-24

Not Used

Digit 25 — System Monitoring Controls

0 = No Monitoring Controls

A = Condensate Drain Pan Overflow Switch

Digit 26 — System Monitoring Controls

B = Economizer Fault Detection and Diagnostics (FDD)⁵

Model Number Notes

Notes:

1. Some field set up required.
2. Must be ordered with Through the- Base Electrical option.
3. All Factory Installed Options are Built-to-Order. Check order services for estimated production cycle.
4. Factory installed economizers only available in downflow configuration.
5. Fault Detection and Diagnostics (FDD) is available on Low Leak Economizers only.

General Information

⚠ WARNING

Fiberglass Wool!

Exposure to glass wool fibers without all necessary PPE equipment could result in cancer, respiratory, skin or eye irritation, which could result in death or serious injury. Disturbing the insulation in this product during installation, maintenance or repair will expose you to airborne particles of glass wool fibers and ceramic fibers known to the state of California to cause cancer through inhalation.

You **MUST** wear all necessary Personal Protective Equipment (PPE) including gloves, eye protection, a NIOSH approved dust/mist respirator, long sleeves and pants when working with products containing fiberglass wool.

Precautionary Measures:

- Avoid breathing fiberglass dust.
- Use a NIOSH approved dust/mist respirator.
- Avoid contact with the skin or eyes. Wear long-sleeved, loose-fitting clothing, gloves, and eye protection.
- Wash clothes separately from other clothing; rinse washer thoroughly.
- Operations such as sawing, blowing, tear-out, and spraying may generate fiber concentrations requiring additional respiratory protection. Use the appropriate NIOSH approved respirator.

First Aid Measures:

- **Eye Contact** - Flush eyes with water to remove dust. If symptoms persist, seek medical attention.
- **Skin Contact** - Wash affected areas gently with soap and warm water after handling.

- Inspect the complete exterior for signs of shipping damages to unit or packing material.
- Verify that the nameplate data matches the sales order and bill of lading.
- Verify that the unit is properly equipped and there are no material shortages.
- Verify the power supply complies with the unit nameplate specifications.

Inspection for Concealed Damage

Inspect the components for concealed damage as soon as possible after delivery and before it is stored.

If concealed damage is discovered:

- Notify the carrier's terminal of the damage immediately by phone and by mail.
- Concealed damage must be reported within 15 days.
- Request an immediate, joint inspection of the damage with the carrier and consignee.
- Stop unpacking the unit.
- Do not remove damaged material from receiving location.
- Take photos of the damage, if possible.
- The owner must provide reasonable evidence that the damage did not occur after delivery.

Unit Storage

Take precautions to prevent condensate from forming inside the unit's electrical compartments and motors if:

- The unit is stored before it is installed; or,
- The unit is set on the roof curb, and temporary heat is provided in the building. Isolate all side panel service entrances and base pan openings (e.g., conduit holes, S/A and R/ A openings, and flue openings) from the ambient air until the unit is ready for start-up.

Note: Do not use the unit's heater for temporary heat without first completing the start-up.

The manufacturer will not assume any responsibility for equipment damage resulting from condensate accumulation on the unit's electrical and/or mechanical components.

Unit Inspection

To protect against loss due to damage incurred in transit, perform inspection immediately upon receipt of the unit. Check carefully for shipping damage. If any damage is found, report it immediately, and file a claim against the transportation company.

Exterior Inspection

If the job site inspection reveals damage or material shortages, file a claim with the carrier immediately. Specify the type and extent of the damage on the bill of lading before signing. Notify the appropriate sales representative.

Important: Do not proceed with installation of a damaged unit without sales representative approval.

Unit Description

Before shipment, each unit is leak tested, dehydrated, charged with refrigerant and compressor oil, and run tested for proper control operation.

Direct-drive, vertical discharge condenser fans are provided with built-in thermal overload protection. The stages of capacity control for these units are achieved by starting the Economizer Control Actuator (ECA).

Economizer Control Actuator Electromechanical Control

The ECA monitors the mixed air temperature, return air temperature, minimum position setpoint (local or remote), power exhaust setpoint, CO₂ setpoint, CO₂, and ambient dry bulb/ enthalpy sensor or comparative humidity (return air humidity against ambient humidity) sensors, if selected, to control dampers to an accuracy of ±5 percent of stroke. The actuator is spring returned to the closed position any time that power is lost to the unit. It is capable of delivering up to 25 in.lb of torque and is powered by 24 Vac.

JADE Economizer Control - Low Leak Economizer (LLE) Only

The JADE controller is a standalone economizer controller that provides outdoor air dry-bulb economizer control standard. With optional Sylk Bus sensors, the controller can provide comparative or reference enthalpy control. Dampers are controlled to an accuracy of ±3.2 percent of stroke. The actuator is spring returned to the closed position any time that power is lost to the actuator. It is capable of delivering up to 88 in.lb of torque and is powered by 24 Vac.

System Input Devices and Functions

The unit must have a thermostat input in order to operate.

For units with Low Leak Economizer (LLE), the thermostat must be a smart thermostat as listed by the CEC (a list of thermostats can be found at http://www.energy.ca.gov/title24/equipment_cert/ocst/index.html).

The descriptions of the following basic input devices used within the unit are to acquaint the operator with their function as they interface with the various features. Refer to the unit's electrical schematic for the specific device connections. The following controls are available from the factory for field installation.

Drain Pan Condensate Overflow Switch (Optional)

This input incorporates the Condensate Overflow Switch (COF) mounted on the drain pan. When the condensate level reaches the trip point, the COF relay energizes and opens the 24 Vac control circuit, disabling the unit. A delay timer prevents the unit from starting for 3 minutes.

Phase Monitor

The Phase Monitor is a three-phase line monitor module that protects against phase loss, phase reversal and phase unbalance. It is intended to protect compressors from reverse rotation. It has an operating input voltage range of 180–600 Vac, and LED indicators for ON and FAULT. There are no field adjustments and the module will automatically reset from a fault condition.

Discharge Line Thermostat Control

The high pressure controls and the discharge line thermostat signals are wired in series and connected to the

safety input of the LSD. The compressor contactor coil is connected to the 'CC' terminal of the LSD. If the high pressure control switch or the discharge line thermostat is open, the 24 Vac signal to the SI input of the LSD is interrupted and the compressor contactor coil supply is disabled by the LSD. It has an automatic lockout.

Power Exhaust Control (Optional)

The power exhaust fan is started whenever the position of the economizer dampers meets or exceed the power exhaust setpoint when the indoor fan is on.

The setpoint panel is located in the return air section and is factory set at 25% (50% for LLE).

To configure the LLE controller, set EXH1 SET (or EXH1 L & EXH1 H with two-speed fan) in the SETPOINTS menu. 2-speed fan mode requires AUX2 I set as W.

Evaporator Frost Control

This input incorporates the Froststat™ control (FOS) mounted in the indoor coil and can be activated by closing a field supplied contact installed in parallel with the FOS.

If this circuit is open before the compressor is started, the compressor will not be allowed to operate. Anytime this circuit is opened for 5 continuous seconds during compressor operation, the compressor for that circuit is immediately turned "Off". The compressor will not be allowed to restart for a minimum of 3 minutes should the FOS close.

Locking Safety Device with Anti-Short Cycle Timer

This device monitors compressor safety switch trips to prevent short cycling, protecting the compressor. A manual reset is required after a fourth safety switch trip.

Sensors

High Temperature Sensor (BAYFRST003*)

This sensor connects to the Emergency Stop Input on the LTB and provides high limit "shutdown" of the unit. The sensor is used to detect high temperatures due to fire in the air conditioning or ventilation ducts. The sensor is designed to mount directly to the sheet metal duct. Each kit contains two sensors. The return air duct sensor (X1310004001) is set to open at 135°F.

The supply air duct sensor (X1310004002) is set to open at 240°F. The control can be reset after the temperature has been lowered approximately 25°F below the cutout setpoint.

Thermostat (TCONT802AS32DA)

This thermostat is a multi-stage 3 heat/2 cool, autochangeover digital display thermostat. It is a programmable thermostat, and a 7-day programmable stat with night setback shall be available. In addition, it is wall mounted.

Thermostat (TCONT402AN32DA)

This thermostat is a multi-stage 3 heat/2 cool, auto changeover digital display thermostat. It is a nonprogrammable, wall-mounted thermostat, and it can be used for economizer operation.

CO₂ Sensor

This optional sensor can be added for Demand Control Ventilation (DCV) functionality. On units with a low leak economizer, configure the JADE controller by setting the following parameters:

Setpoints Menu

DCV SET = desired CO₂ ppm to start DCV

VENTMAX = desired maximum position w/DCV and occupied status (2-speed applications require LO and HI settings)

VENTMIN = desired minimum position w/DCV and occupied status (2-speed applications require LO and HI settings)

ADVANCED SETUP Menu:

CO₂ ZERO = set to detector's start level

CO₂ SPAN = detector's max level minus start level

Attach the sensor to the CO₂ and "R" terminals (at customer connections).

Note: When using any 0-10 Vdc CO₂ sensor with the JADE you will need to set CO₂ ZERO to 400 ppm and the CO₂ SPAN to 1600 ppm in the ADVANCED SETUP menu.

Occupancy Sensor

A customer-supplied occupancy sensor can also be added to provide damper control based on occupied/unoccupied conditions.

Low Leak Economizer Units

To configure the JADE controller, set:

SYSTEM SETUP menu: OCC = INPUT

Attach the occupancy sensor to the OCC SENSOR wire and "R" terminal (at customer connections). The occupancy sensor must utilize a normally open contact for proper operation.

If an occupancy sensor is not used, another option to controlling occupied and unoccupied status is to use the 'G' input (fan is running). Connect the G input to the OCC SENSOR wire (at customer connections). The controller will then operate in the occupied mode every time the indoor fan is running.

Initiation of Operating Modes - JADE Controller

The JADE controller is able to initiate the following modes: Compressor, Economizer, Fans, Heating System, and Cooling System.

The Compressor mode is initiated by either the OAT going above the DRYBLB SET setting or by the thermostat initiating a call to cool when the damper is at 100% open. The Economizer mode is controlled by the MAT getting above the MAT SET setting while the OAT is below the DRYBLB SET setting.

While the fans are not controlled by the controller, the Fan mode is dependent on what state the system is in (OCC or Y1 states will cause the damper to go to a LOW fan speed damper setting, while Y2 or W states will cause the controller to open the damper to the HIGH fan speed damper setting). The Heating System mode requires an input to the AUX2-1 terminal from the thermostat, and the Cooling System mode requires an input to the Y2 IN and/or the Y1 IN terminals from the thermostat.

Dimensional Data

Below figure illustrates the minimum operating and service clearances for either a single or multiple unit installation. These clearances are the minimum distances necessary to assure adequate serviceability, cataloged unit capacity, and peak operating efficiency.

Providing less than the recommended clearances may result in condenser coil starvation, "short-circuiting" of exhaust and economizer airflows, or recirculation of hot condenser air.

Figure 1. Typical installation clearance for single and multiple unit applications

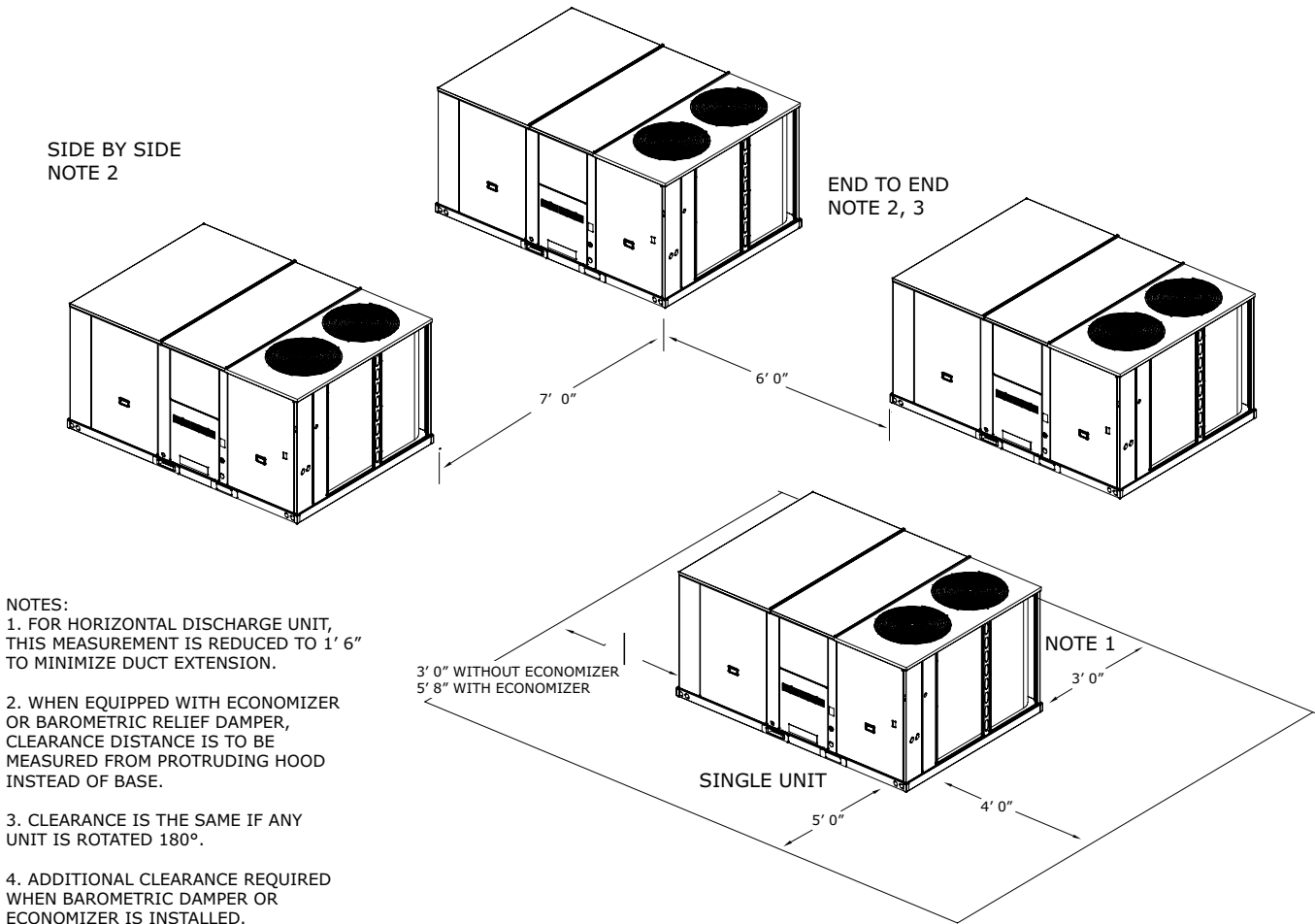

Figure 2. Cooling with optional electrical heat — overview (gas/electric)

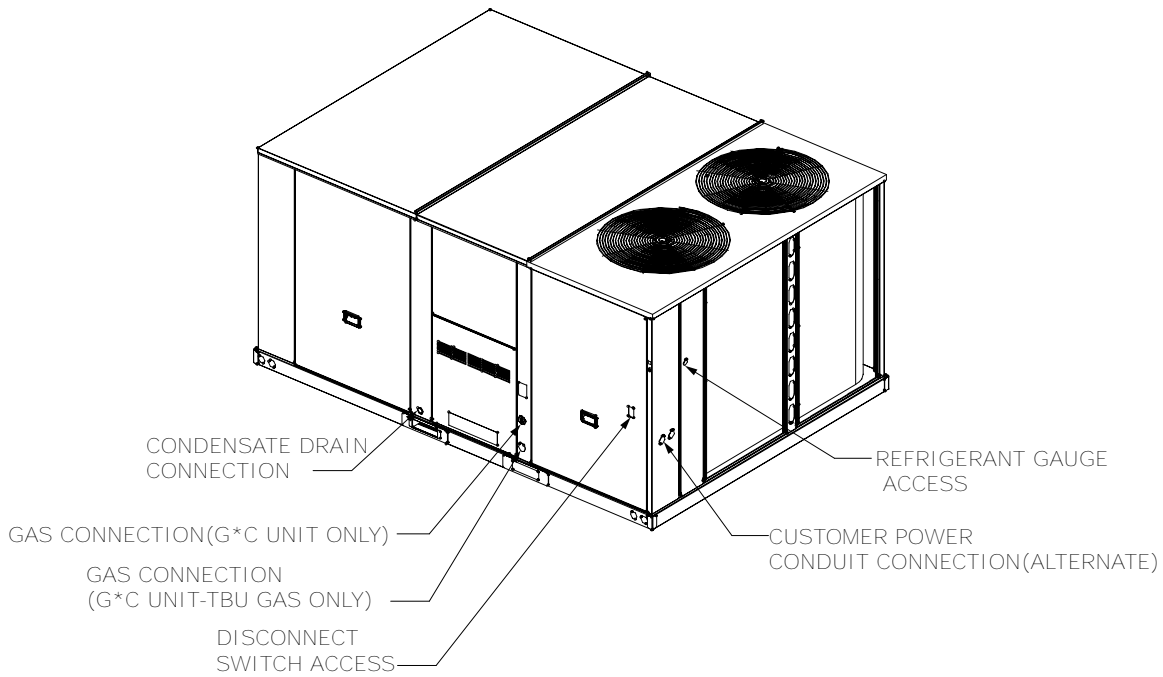
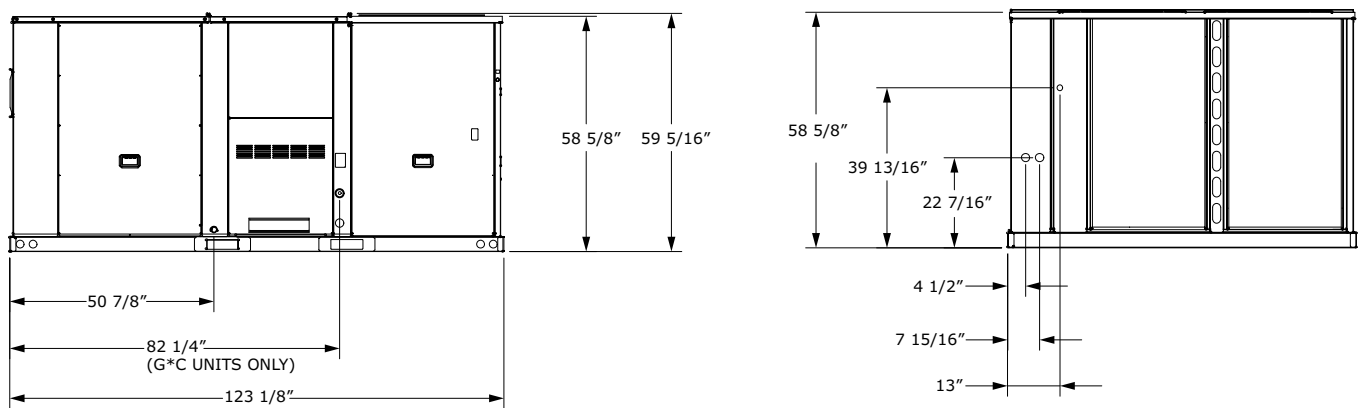

Figure 3. Cooling with optional electrical heat — front and side views (gas/electric)



NOTES:

1. THROUGH THE BASE GAS AND ELECTRICAL IS NOT STANDARD ON ALL UNITS.
2. VERIFY WEIGHT, CONNECTION, AND ALL DIMENSIONS WITH INSTALLER DOCUMENTS BEFORE INSTALLATION.

Figure 6. Cooling with optional electrical heat — roof curb

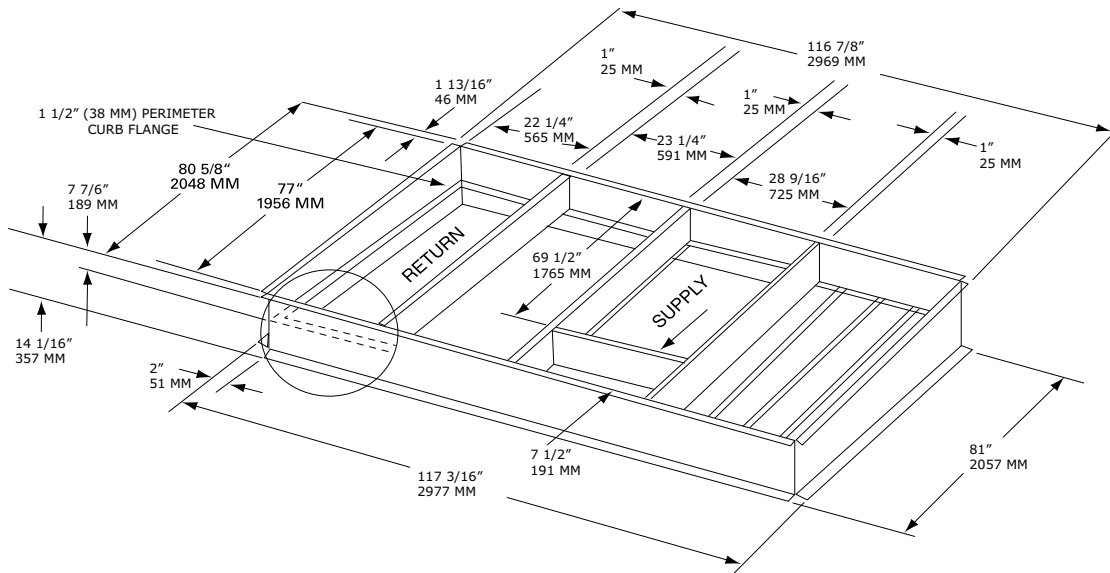
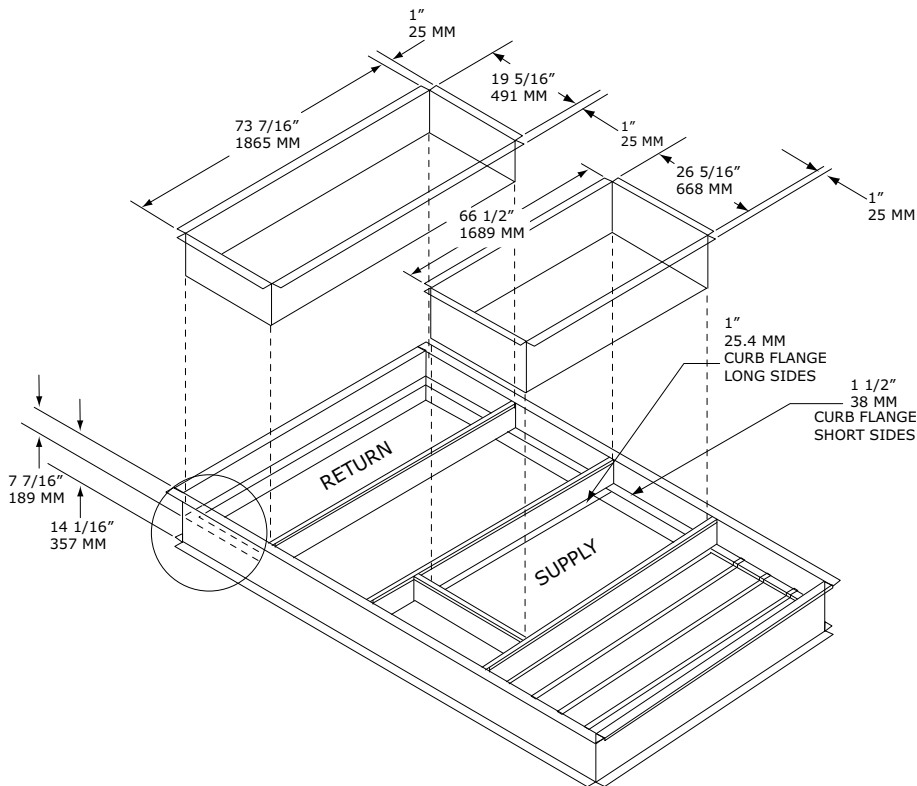

Figure 7. Cooling with optional electrical heat — downflow duct connections—field fabricated



- NOTES:
- DUCT FLANGES MOUNT 7-7/16" DOWN INSIDE THE CURB ON THE 1-1/2" CURB FLANGES.
 - ROOFCURB IS INTENDED FOR DOWNFLOW USE ONLY.

Dimensional Data

Figure 8. Cooling with optional electric heat — downflow unit clearance

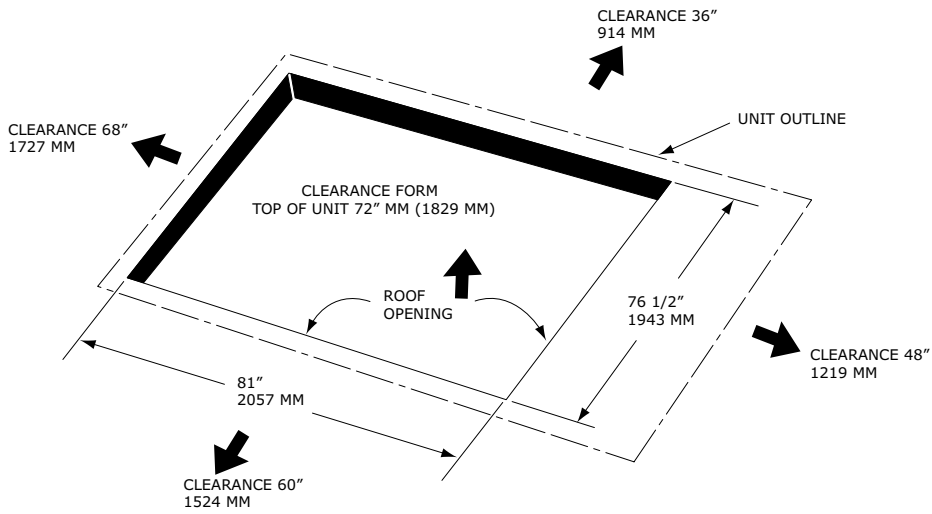
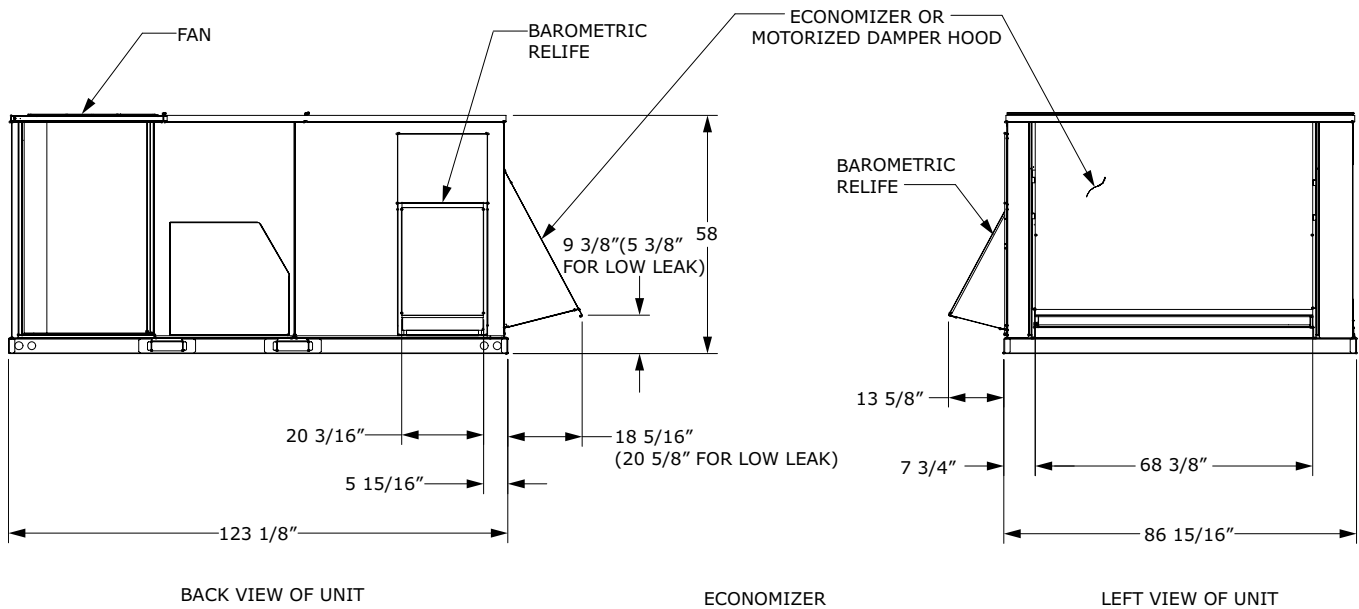

Figure 9. Cooling with optional electric heat — barometric relief and economizer



NOTES:

1. VERIFY WEIGHT, CONNECTION AND ALL DIMENSIONS WITH INSTALLER DOCUMENTS BEFORE INSTALLATION.
2. BAROMETRIC RELIEF IS FOR USE WITH A DOWNFLOW ECONOMIZER ONLY.

Figure 10. Cooling with optional electric heat — manual damper

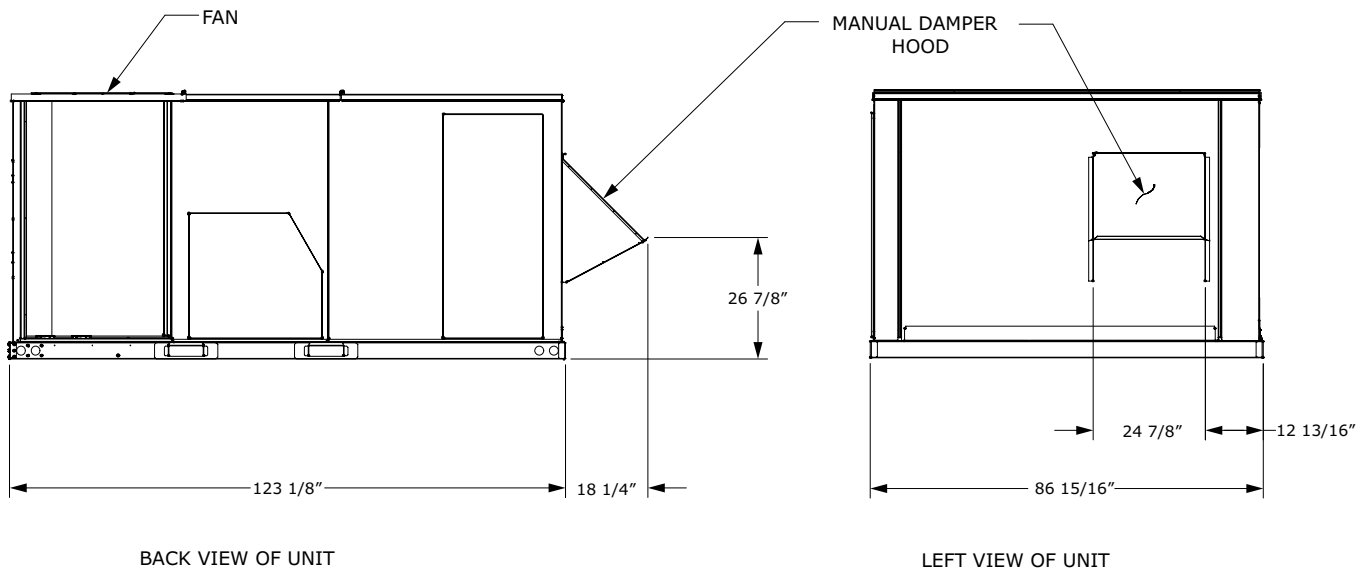

NOTE:
 VERIFY WEIGHT, CONNECTION, AND ALL DIMENSIONS WITH INSTALLER DOCUMENTS BEFORE INSTALLATION.

Weights

Table 1. Maximum unit and corner weights (lb) and center of gravity dimensions (in.)

Tons	Unit Model No.	Weights (lb) ^{(a), (b)}		Corner Weights ^(c)				Center of Gravity (in.)	
		Shipping	Net	A	B	C	D	Length	Width
15	GCC180A	2339	2013	649	508	398	459	55	37
17.5	GCC210A	2353	2028	653	511	399	464	55	37
20	GCC240A	2350	2025	643	512	403	466	55	37
25	GCC300A	2386	2061	671	524	393	472	55	36

^(a) Weights are approximate. Horizontal and downflow unit and corner weights may vary slightly.

^(b) Weights do not include additional factory or field installed options/accessories.

^(c) Corner weights are given for information only. 15 to 25 ton models must be supported continuously by a curb or equivalent frame support.

Figure 11. Corner weights

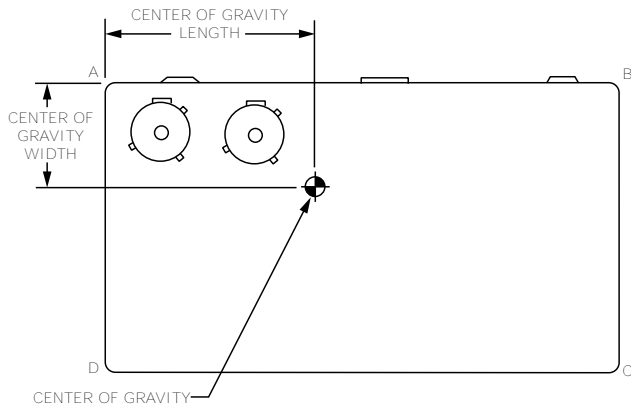

Rigging

⚠ WARNING

Heavy Object!

Failure to follow instructions below could result in unit dropping which could result in death or serious injury, and equipment or property-only damage.

Ensure that all the lifting equipment used is properly rated for the weight of the unit being lifted. Each of the cables (chains or slings), hooks, and shackles used to lift the unit must be capable of supporting the entire weight of the unit. Lifting cables (chains or slings) may not be of the same length. Adjust as necessary for even unit lift.

⚠ WARNING

Improper Unit Lift!

Failure to properly lift unit in a LEVEL position could result in unit dropping and possibly crushing operator/technician which could result in death or serious injury, and equipment or property-only damage.

Test lift unit approximately 24 inches (61 cm) to verify proper center of gravity lift point. To avoid dropping of unit, reposition lifting point if unit is not level.

Refer to [Figure 12, p. 17](#) and , [p. 17](#) for typical unit operating weights rigging before proceeding.

1. Remove the shipping crate from around the unit. Once fork trucking is complete, and unit is ready to place on the curb, remove all fork access brackets to drop the shipping boards from underneath the unit (4 brackets standard forking, 6 brackets for 3 sided forking). Do not remove the crating from the top of the unit.
2. Rig the unit as shown in [Figure 12, p. 17](#). Attach adequate strength lifting slings to all four lifting brackets

in the unit base rail. Do not use cables, chains, or slings except as shown.

3. Install a lifting bar, as shown in [Figure 12, p. 17](#), to protect the unit and to facilitate a uniform lift. The minimum distance between the lifting hook and the top of the unit should be 7 feet.
4. Test-lift the unit to ensure it is properly rigged and balanced, make any necessary rigging adjustments.
5. Lift the unit and position it into place.
6. Downflow units; align the base rail of the unit with the curb rail while lowering the unit onto the curb. Make sure that the gasket on the curb is not damaged while positioning the unit.

Figure 12. Rigging and center of gravity data

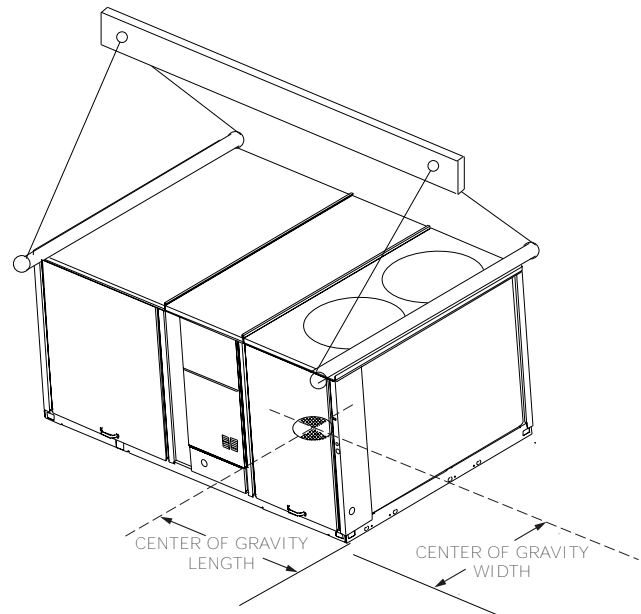

Installation

Unit Foundation

⚠ WARNING

Risk of Roof Collapsing!

Failure to ensure proper structural roof support could cause the roof to collapse, which could result in death or serious injury and property damage.

Confirm with a structural engineer that the roof structure is strong enough to support the combined weight of the roof curb, the unit, and any accessories.

NOTICE

Water Damage!

Failure to follow instructions below could result in equipment and property damage.

Non-factory penetrations through the base of this unit are not allowed. Any penetration in the base of the unit may affect the water tight integrity of the unit and lead to water leaks into the conditioned space.

NOTICE

Roof Damage!

System contains oil and refrigerant under high pressure. Roofs should be protected from exposure to oils and refrigerant in the system. If rooftop is not protected, damage to the roof may occur.

Important: Refer to local building codes for proper installation. All installation must comply with local building codes.

Horizontal Units

Notes:

- For complete step by step instructions on how to install a Horizontal Conversion Kit, please refer to ACCSVN159*- EN.
- For units with optional Condensate Overflow Switch (COF), the switch will not work properly if unit is not level or slightly sloped toward switch.
- To assure proper condensate flow during operation the unit and the curb must be level.

If the unit is installed at ground level, elevate it above the snow line. Provide concrete footings at each support location with a “full perimeter” support structure or a slab foundation for support. Refer to , p. for the unit’s operating and point loading weights when constructing a footing foundation.

If anchoring is required, anchor the unit to the slab using hold down bolts or isolators. Isolators should be installed to minimize the transmission of vibrations into the building.

For rooftop applications, if anchoring is required, anchor the unit to the roof with hold-down bolts or isolators.

Check with a roofing contractor for proper waterproofing procedures.

Ductwork

Elbows with turning vanes or splitters are recommended to minimize air noise due to turbulence and to reduce static pressure.

When attaching the ductwork to the unit, provide a watertight flexible connector at the unit to prevent operating sounds from transmitting through the ductwork.

All outdoor ductwork between the unit and the structure should be weather proofed after installation is completed.

Note: For sound consideration, cut only the holes in the roof deck for the ductwork penetrations. Do not cut out the entire roof deck within the curb perimeter.

If a Curb Accessory Kit is not used:

1. The ductwork can be attached directly to the factory-provided flanges around the unit’s supply and return air openings. Be sure to use flexible duct connections at the unit.
2. For “built-up” curbs supplied by others, gaskets must be installed around the curb perimeter flange and the supply and return air opening flanges.

General Unit Requirements

⚠ WARNING

Proper Field Wiring and Grounding Required!

Failure to follow code could result in death or serious injury.

All field wiring **MUST** be performed by qualified personnel. Improperly installed and grounded field wiring poses **FIRE** and **ELECTROCUTION** hazards. To avoid these hazards, you **MUST** follow requirements for field wiring installation and grounding as described in **NEC** and your local/state/national electrical codes.

The checklist listed below is a summary of the steps required to successfully install a commercial unit. This checklist is intended to acquaint the installing personnel with what is required in the installation process. It does not replace the detailed instructions called out in the applicable sections of this manual.

- Check the unit for shipping damage and material shortage; file a freight claim and notify appropriate sales representative.
- Verify correct model, options and voltage from nameplate.
- Verify that the installation location of the unit will provide the required clearance for proper operation.

- Assemble and install the roof curb (if applicable). Refer to the latest edition of the curb installers guide that ships with each curb kit.
- Fabricate and install ductwork; secure ductwork to curb.
- Rigging the unit.
- Set the unit onto the curb; check for levelness.
- Ensure unit-to-curb seal is tight and without buckles or cracks.
- Install and connect a condensate drain line to the evaporator drain connection.

Factory Installed Economizer

- Ensure the economizer has been pulled out into the operating position. Refer to the standard or low leak economizer Installation Instructions for proper position and setup.
- Install all access panels.

Controller Wiring Schematic - LLE

For additional information, go to the Installation Instructions ACC-SVN178*-EN.

Main Electrical Power Requirements

- Verify that the power supply complies with the unit nameplate specifications.
- Inspect all control panel components; tighten any loose connections.
- Connect properly sized and protected power supply wiring to a field-supplied/ installed disconnect switch and to the main power terminal block (HTB1) in the unit control panel.
- Install proper grounding wires to an earth ground.

Note: All field-installed wiring must comply with NEC and applicable local codes.

External Vent Hood Installation

Note: This procedure applies only to medium and high heat options, not to the low heat option.

⚠ WARNING

Hazardous Voltage!

Failure to disconnect power before servicing could result in death or serious injury.

Disconnect all electric power, including remote disconnects before servicing. Follow proper lockout/tagout procedures to ensure the power can not be inadvertently energized. Verify that no power is present with a voltmeter.

1. Remove and discard the cover plate located on the gas heat panel.

Important:

- Make sure you read the label located on the cover plate before you discard it.
- Do not discard the fastening screws! They will be needed to install the vent hood.

Figure 13. Discard cover plate

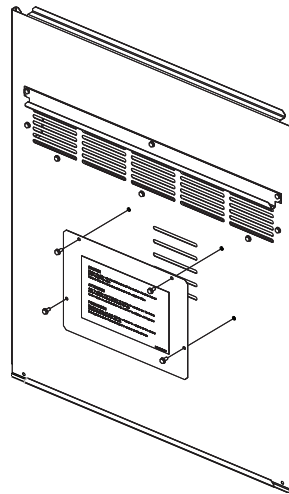

2. Locate the vent hood behind the panel, on the left side of the burner assembly.

Figure 14. Vent hood shipping location

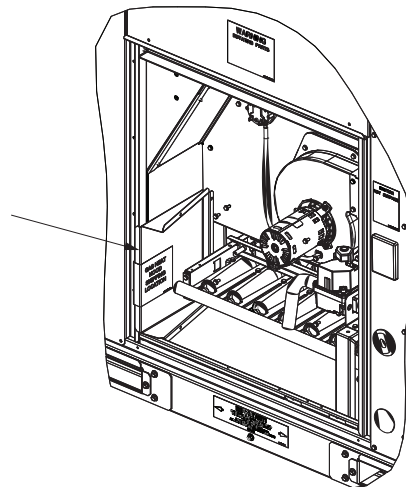

3. Install the vent hood on the gas heat panel using the screws removed in Step 1. Make sure it is properly secured to the panel.

Figure 15. Vent hood installation

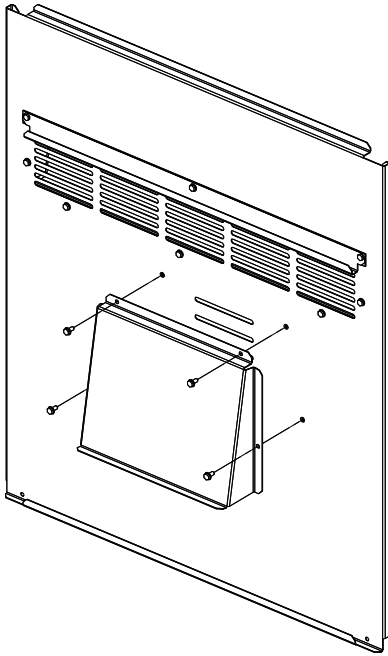

TCO1 Instructions

If the unit is installed in horizontal configuration, the factory installed limit control TCO1 must be replaced with the TCO1 for horizontal applications shipped in the heater compartment.

Replace TCO1 following instructions below.

1. Remove the heat section access panel.
2. Remove TCO1 from shipping location - attached to the gas manifold vertical leg - as shown below:

Figure 16. TCO1 shipping locations

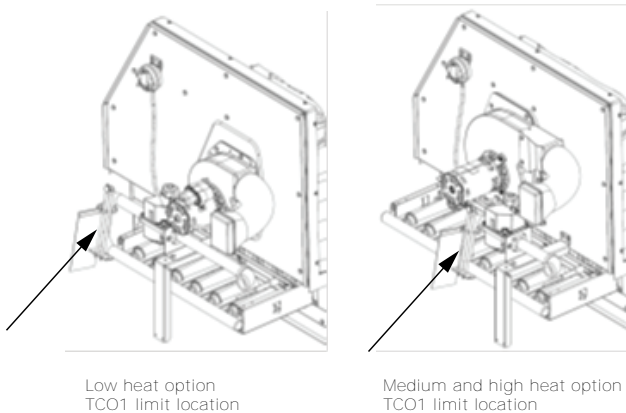

3. Replace and discard the existing TCO1 originally installed at the factory for down flow operation with the TCO1 from Step 2 for horizontal operation.
4. Reinstall the heat section access panel.

Figure 17. Factory installed down flow TCO1 limit location

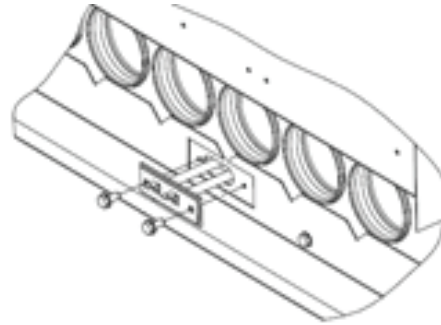

Gas Heater Conversion Instructions

Important: Conversion should be made prior to installation of equipment at job site.

Note: Only Applicable for GCC210A*E (H, Z)

If the unit is installed in a horizontal configuration, the factory-installed gas orifice spuds, air orifice plate, and TCO1 limit must be replaced with the gas orifice spuds, air orifice plate, and TCO1 limit for horizontal applications shipped in the heater compartment.

Installation instructions:

1. Remove the gas heat section access panel.
2. Remove ship-with parts attached to the gas manifold vertical leg. See the following figure.

Figure 18. Gas orifice spuds, air orifice, supplement heating data label shipping location

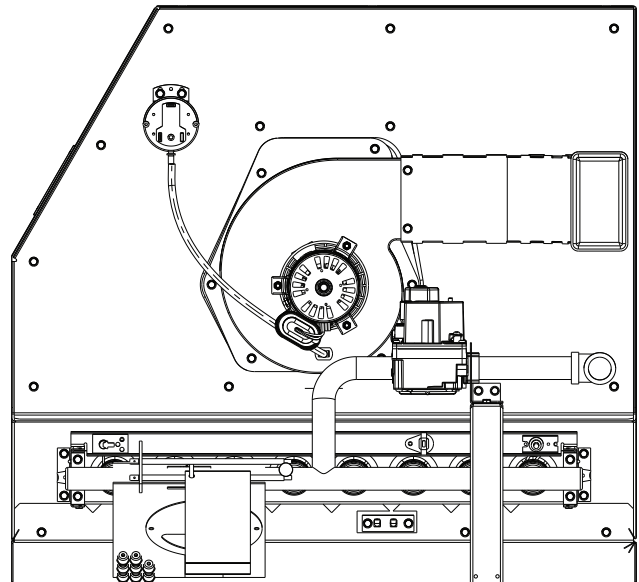

3. Remove six screws from manifold bracket. See the following figure.

Figure 19. Remove screws from manifold assembly

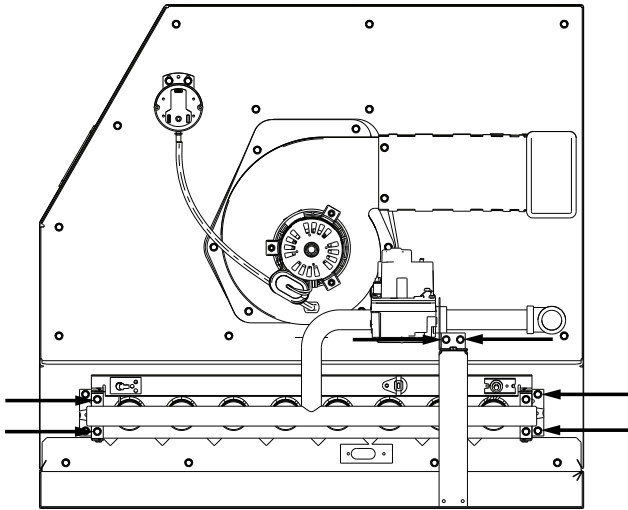

4. Remove the natural gas orifice spuds from the manifold. See the following figure.
5. Install the ship-with, natural gas orifice spuds. Engage threads of manifold and tighten orifice three- and one-half turns.

Note: Do not overtorque gas orifice spuds.

Figure 20. Remove orifice spuds

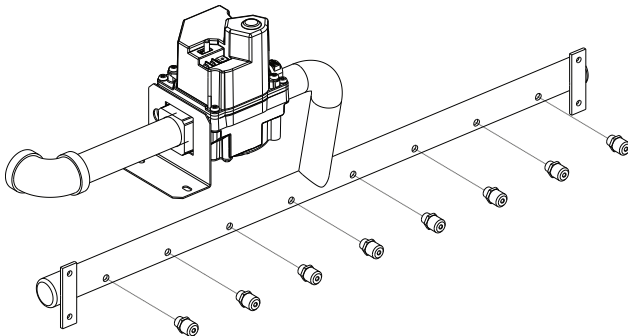

6. Disconnect the inducer motor wiring harness.
7. Remove six screws securing the inducer blower assembly. See Figure 21, and Figure 22.
8. Remove three screws securing the air orifice plate. See the following figure.
9. Using three screws install the ship-with, air orifice plate.

Figure 21. Remove screws from inducer blower assembly and air orifice plate

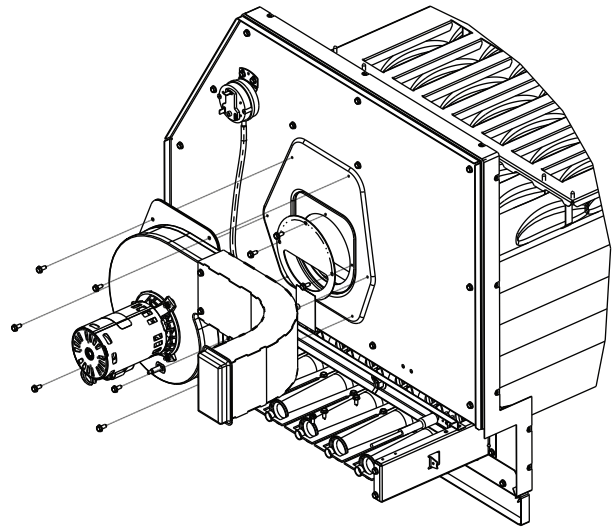
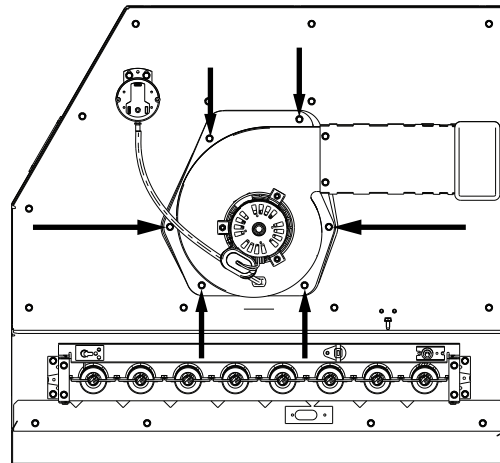
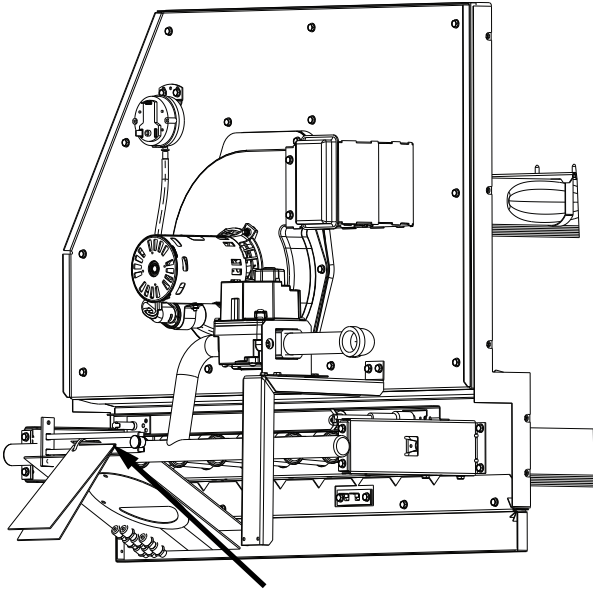

Figure 22. Remove screws from inducer blower assembly



10. Install the inducer blower assembly using six screws. Confirm exhaust screen is positioned properly in the center ID post. See Figure 22.
11. Connect the inducer blower wire harness.
12. Install the manifold bracket using six screws.
13. Remove the TCO1 limit attached to the gas manifold vertical leg. See Figure 23.
14. Remove and discard the factory-installed, downflow TCO1 limit.
15. Install the ship-with TCO1 limit for horizontal operation. See Figure 24.
16. Re-install the gas heat access panel.

Figure 23. TCO1 limit ship-with location



17. Once the conversion is complete, scratch off the ink square (to the right-hand side). **SCRATCH INK OFF SQUARE WHEN USING SUPPLEMENTAL HEATING DATA** on both English and French nameplate.
18. Paste the ship-with supplemental heating data label over the existing heating data on both English and French nameplate. See Figure 25.

Figure 24. TCO1 limit factory-installed location

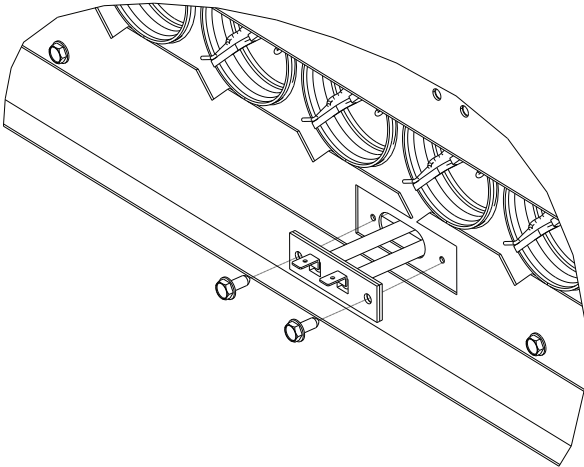
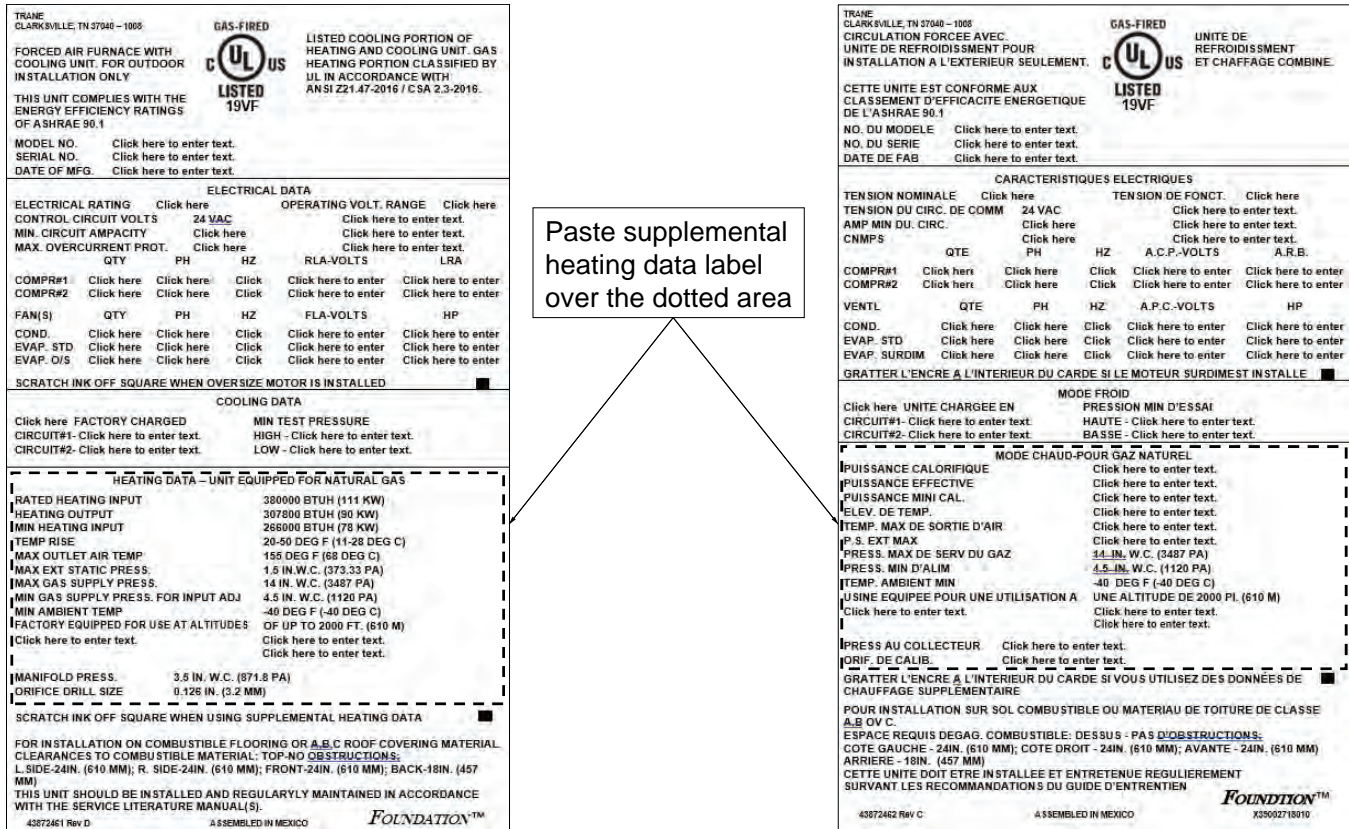

Figure 25. Location for pasting supplemental heating data label



Condensate Drain Configuration

An evaporator condensate drain connection is provided on each unit. Refer to “Dimensional Data,” p. 10 for the appropriate drain location.

Note: Use 1-inch PVC pipe to connect to the drain pan outlet provided in the unit. This is a slip fit joint (no threads). Do not use PVC glue to connect condensate drain, thread sealing compound or Teflon tape may be used.

A condensate trap must be installed at the unit due to the drain connection being on the “negative pressure” side of the fan.

A condensate drain line must be connected to the P-Trap. Pitch the drain lines at least 0.5-inch for every 10 feet of horizontal run to assure proper condensate flow. Do not allow the horizontal run to sag causing a possible doubletrap condition which could result in condensate backup due to “air lock”.

Filter Installation

Each unit ships with 2-inch filters installed. The quantity of filters is determined by unit size. Access to the filters is obtained by removing the filter access panel.

Refer to the unit Service Facts (shipped with each unit) for filter requirements

Note: Do not operate the unit without filters.

Field Installed MERV13 Filters

Optional MERV13 filters are available for purchase. Replace standard filters with MERV13 Filters according to the installation instructions provided in the kit.

Field Installed Power Wiring

An overall dimensional layout for the standard field installed wiring entrance into the unit is illustrated in “Dimensional Data,” p. 10. To insure the unit’s supply power wiring is properly sized and installed, follow the guidelines outlined below.

Note: All field installed wiring must conform to NEC guidelines as well as state and Local codes.

Verify that the power supply available is compatible with the unit’s nameplate ratings. The available supply power must be within 10 percent of the rated voltage stamped on the nameplate. Use only copper conductors to connect the power supply to the unit.

NOTICE

Use Copper Conductors Only!

Failure to use copper conductors could result in equipment damage as the equipment was not designed or qualified to accept other types of conductors.

Note: If the unit is not equipped with an optional factory installed nonfused disconnect switch or circuit breaker, a field supplied disconnect switch must be installed at or near the unit in accordance with the National Electrical Code (NEC latest edition).

Main Unit Power

⚠ WARNING

Proper Field Wiring and Grounding Required!

Failure to follow code could result in death or serious injury.

All field wiring **MUST** be performed by qualified personnel. Improperly installed and grounded field wiring poses **FIRE** and **ELECTROCUTION** hazards. To avoid these hazards, you **MUST** follow requirements for field wiring installation and grounding as described in NEC and your local/state/national electrical codes.

Standard Wiring

The electrical service must be protected from over current and short circuit conditions in accordance with NEC requirements.

Protection devices must be sized according to the electrical data on the nameplate.

- If the unit is not equipped with an optional factory installed nonfused disconnect switch, a field supplied disconnect switch must be installed at or near the unit in accordance with the National Electrical Code (NEC latest edition).
- Location of the applicable electrical service entrance is illustrated in “Dimensional Data,” p. 10. Complete the unit’s power wiring connections onto either; the main terminal block HTB1 inside the unit control panel, the factory mounted nonfused disconnect switch (UCD), or the electric heat terminal block. Refer to the customer connection diagram that shipped with the unit for specific termination points.
- Provide proper grounding for the unit in accordance with local and national codes.

Optional TBUE Wiring (Through the Base Electrical Option)

- Location of the applicable electrical service is illustrated below. Refer to the customer connection diagram that is shipped with the unit for specific termination points. The termination points, depending on the customer option selected would be a factory mounted nonfused disconnect switch (UDC).
- Provide proper grounding for the unit in accordance with local and national codes.

Figure 26. Through the base electrical option

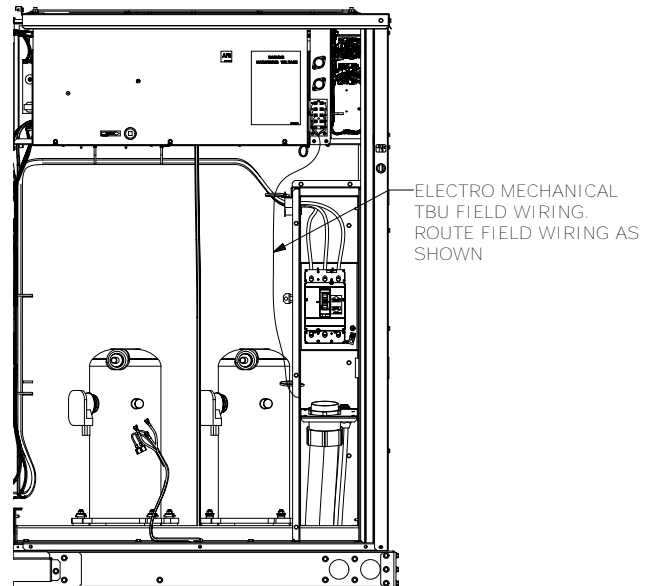

Control Power Transformer

The 24-volt control power transformers are to be used only with the accessories called out in this manual.

Transformers rated greater than 50 Vac are equipped with internal circuit breakers. If a circuit breaker trips, turn “Off” all power to the unit before attempting to reset it.

The transformer is located in the control panel. The circuit breaker is located on the left side of the transformer and can be reset by pressing in on the black reset button.

Controls using 24 Vac

Before installing any connecting wiring, refer to “Dimensional Data,” p. 10 for the electrical access locations provided on the unit and Table 2, p. 25 for AC conductor sizing guidelines.

NOTICE

Use Copper Conductors Only!

Failure to use copper conductors could result in equipment damage as the equipment was not designed or qualified to accept other types of conductors.

1. Use copper conductors unless otherwise specified.
2. Ensure that the AC control wiring between the controls and the unit’s termination point does not exceed three (3) ohms/conductor for the length of the run.
Note: Resistance in excess of 3 ohms per conductor could cause component failure due to insufficient AC voltage supply.
3. Be sure to check all loads and conductors for grounds, shorts, and mis-wiring.
4. Do not run the AC low voltage wiring in the same

conduit with the high voltage power wiring.

5. Route low voltage wiring as per [Figure 27, p. 25](#).

Table 2. Electromechanical thermostat 24V AC conductors with electromechanical unit

Distance from Unit to Control	Recommended Wire Size
0 - 30 feet	22 gauge
0 - 9.1 m	0.33 mm ²
31 - 50 feet	20 gauge
9.5 - 15.2 m	0.50 mm ²
51 - 75 feet	18 gauge
15.5 - 22.9 m	0.75 mm ²
76 - 125 feet	16 gauge
23.1 - 38.1 m	1.3 mm ²
126 - 200 feet	14 gauge
38.4 - 60.9 m	2.0 mm ²

Figure 27. Conventional thermostat field wiring diagram

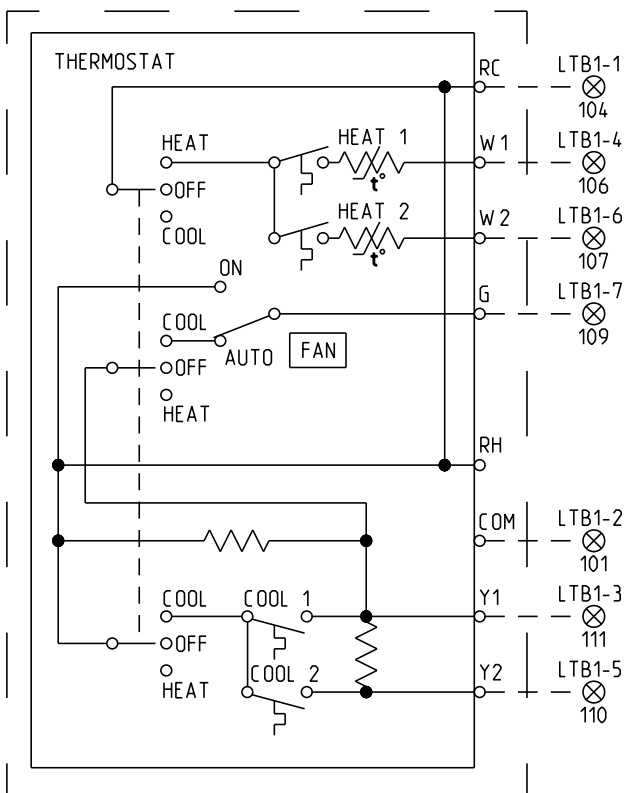

Requirements of Gas Heat

The unit gas train and optional through-the-base gas shut-off valve are rated at 0.50 PSIG maximum. A pressure reducing regulator is recommended to prevent this maximum from being exceeded. These components must be isolated during field gas piping test that exceed 0.50 PSIG. It is recommended that the field piping be capped prior to the unit gas train or optional through-the-base gas shut-off valve if present.

- Gas supply line properly sized and connected to the unit gas train.
- All gas piping joints properly sealed.
- Gas piping leak checked with a soap solution. If piping connections to the unit are complete, do not pressurize piping in excess of 0.50 PSIG or 14-inch W.C. to prevent component failure.
- Drip leg installed in the gas piping near the unit.

Installation

- Flue Exhaust clear of any obstruction

Gas Heat Data

Table 3. Gas heater operating data

Heating Input Rate—Btu/h	240,000	320,000	350,000	380,000
Minimum Supply Gas Pressure Natural/LP	5.0/11.0	5.0/11.0	4.5/11.0	5.5/11.0
Manifold Gas Pressure	3.2-3.5	3.2-3.5	3.2-3.5	3.2-3.5
Combustion Blower Suction Pressure (1 st Stage)	-0.6 to -0.8	-0.6 to -0.8	-0.6 to -0.8	-0.6 to -0.8
Combustion Blower Suction Pressure (2 nd Stage)	-1 to -1.3	-1 to -1.3	-1 to -1.3	-1 to -1.3
Minimum Flame Sensing Current ^(a)	5.0 Micro Amps DC			
Normal Sensing Current Range	8.0 to 16 Micro Amps DC			
Flue Gas Temperature Rise Above Ambient	300 to 450° F			
Flue Gas Content - % CO ₂	7.5 to 8.5% (Natural Gas) 8.5 to 9.5% (LP)			
Minimum Supply Air Temperature Across Heat Exchanger	40° F			

^(a) A voltage reading across pens (V+) and (V-) is equatable to the flame sensing current. One volt equals one micro amp.

Table 4. Piping

Length of Pipe (ft)	Iron Pipe Size (IPS) Inches				
	1/2" Pipe	3/4" Pipe	1" Pipe	1 1/4" Pipe	1 1/2" Pipe
15	76	176	345	750	1220
30	52	120	241	535	850
45	43	99	199	435	700
60	38	86	173	380	610
75	77	155	345	545	

Note: Capacity of Pipe of Different Diameters and Lengths in Cu. Ft. Per Hr. with Pressure Drop of 0.3" and Specific Gravity of 0.60.

Table 5. Specific gravity multipliers

Specific Gravity	Multipliers
0.50	1.10
0.55	1.04
0.60	1.00
0.65	0.96

Figure 28. Schematic diagram for field gas piping to units

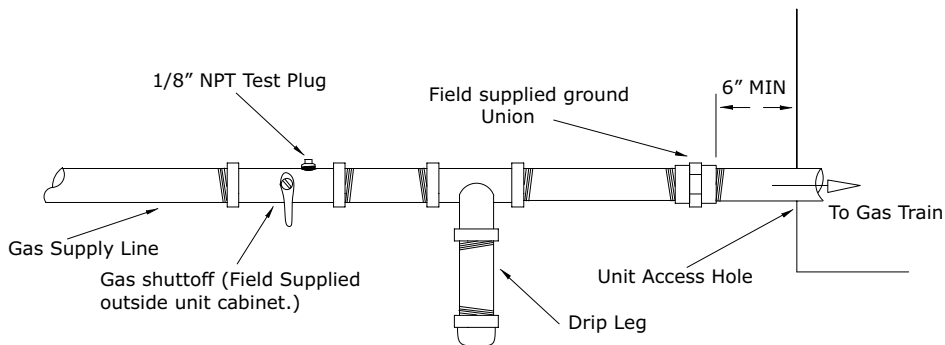
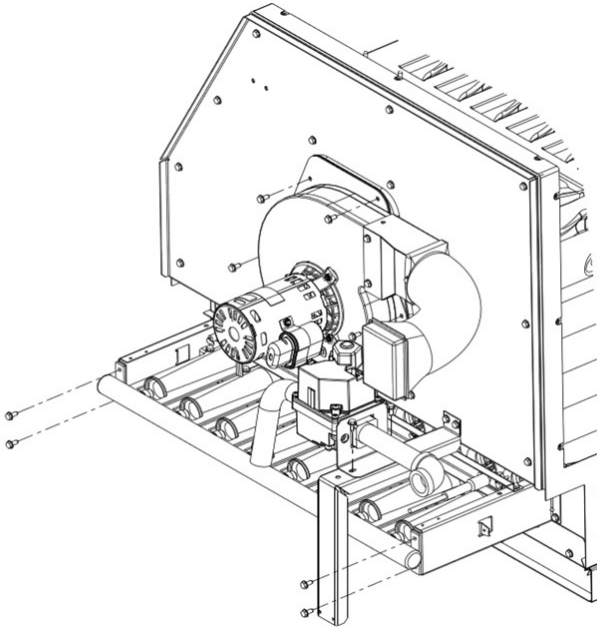

Figure 29. Typical unit gas train configuration



Voltage Imbalance

Three phase electrical power to the unit must meet stringent requirements for the unit to operate properly. Measure each leg (phase-to-phase) of the power supply.

Each reading must fall within the utilization range stamped on the unit nameplate. If any of the readings do not fall within the proper tolerances, notify the power company to correct this situation before operating the unit.

Excessive three phase voltage imbalance between phases will cause motors to overheat and eventually fail. The maximum allowable voltage imbalance is 2 percent.

Measure and record the voltage between phases 1, 2, and 3 and calculate the amount of imbalance as follows:

% Voltage Imbalance = (100 x AV - VD) / AV where;

- V1, V2, V3 = Line voltage readings
- AV (Average Voltage) = (V1 + V2 + V3) / 3
- VD = Line voltage reading that deviates the farthest from the average voltage

Example:

The supply power line voltage readings (V1, V2, V3) are 221, 230, and 227 respectively.:

- AV (Average Voltage) = (221 + 230 + 227) / 3 = 226 Avg.
- VD (reading farthest from average) = 221
- % Voltage Imbalance = (100 + 226 - 221) / 226 = 2.2%

The 2.2 percent imbalance in this example exceeds the maximum allowable imbalance of 2.0 percent. This much imbalance between phases can equal as much as a 20

percent current imbalance with a resulting increase in motor winding temperatures that will decrease motor life.

If the voltage imbalance is over 2 percent, notify the proper agencies to correct the voltage problem before operating this equipment.

Electrical Phasing (Three Phase Motors)

The compressor motor(s) and the supply fan motor are internally connected for the proper rotation when the incoming power supply is phased as A, B, C.

Proper electrical supply phasing can be quickly determined and corrected before starting the unit by using an instrument such as an Associated Research Model 45 Phase Sequence Indicator and following the steps below:

⚠ WARNING

Hazardous Voltage!
 Failure to disconnect power before servicing could result in death or serious injury.
 Disconnect all electric power, including remote disconnects before servicing. Follow proper lockout/tagout procedures to ensure the power can not be inadvertently energized. Verify that no power is present with a voltmeter.

1. Turn the field supplied disconnect switch that provides power to the main power terminal block or to the "Line" side of the optional factory mounted disconnect switch to the "Off" position.
2. Connect the phase sequence indicator leads to the terminal block or to the "Line" side of the optional factory mounted disconnect switch as follows:
 - Black (phase A) to L1
 - Red (phase B) to L2
 - Yellow (phase C) to L3
3. Close the field supplied main power disconnect switch or circuit protector switch that provides the supply power to the unit.

⚠ WARNING

Live Electrical Components!
 Failure to follow all electrical safety precautions when exposed to live electrical components could result in death or serious injury.
 When it is necessary to work with live electrical components, have a qualified licensed electrician or other individual who has been properly trained in handling live electrical components perform these tasks.

4. Observe the ABC and CBA phase indicator lights on the face of the sequencer. The ABC indicator light will glow if the phase is ABC. If the CBA indicator light glows, open the disconnect switch or circuit protection switch and reverse any two power wires.

- Restore the main electrical power and recheck the phasing. If the phasing is correct, open the disconnect switch or circuit protection switch and remove the phase sequence indicator.

Compressor Crankcase Heaters

NOTICE

Compressor Failure!

Failure to follow instruction below could result in compressor failure.

Unit must be powered and crankcase heaters energized at least 8 hours BEFORE compressors are started.

Each compressor can be equipped with a crankcase heater. The proper operation of the crankcase heater is important to maintain an elevated compressor oil temperature during the “Off” cycle to reduce oil foaming during compressor starts. Oil foaming occurs when refrigerant condenses in the compressor and mixes with the oil. In lower ambient conditions, refrigerant migration to the compressor could increase.

When the compressor starts, the sudden reduction in crankcase pressure causes the liquid refrigerant to boil rapidly causing the oil to foam. This condition could damage compressor bearings due to reduced lubrication and could cause compressor mechanical failures.

Before starting the unit in the “Cooling” mode, set the system switch to the “Off” position and turn the main power disconnect to the “On” position and allow the crankcase heater to operate a minimum of 8 hours.

Before closing the main power disconnect switch, insure that the “System” selection switch is in the “Off” position and the “Fan” selection switch is in the “Auto” position.

Close the main power disconnect switch and the unit mounted disconnect switch, if applicable.

Checklist

Use the following checklist in conjunction with the general checklist (“[General Unit Requirements](#),” p. 18) to ensure that the unit is properly installed and ready for operation.

⚠ WARNING

Hazardous Voltage!

Failure to disconnect power before servicing could result in death or serious injury.

Disconnect all electric power, including remote disconnects before servicing. Follow proper lockout/tagout procedures to ensure the power can not be inadvertently energized. Verify that no power is present with a voltmeter.

- Check all electrical connections for tightness and “point of termination” accuracy.
- Verify that the condenser airflow is unobstructed.

- Verify that the condenser fan and indoor blower turn freely without rubbing and are properly tightened on the shafts.
- Check the supply fan belts for proper tension and the fan bearings for sufficient lubrication. If the belts require adjustment, or if the bearings need lubricating, refer to the maintenance section of this manual for instructions.
- Verify that a condensate trap is installed and the piping is properly sized and pitched.
- Verify that the correct size and number of filters are in place.
- Inspect the interior of the unit for tools and debris and install all panels in preparation for starting the unit.

Factory-Mounted Unit Options

Unit Disconnect (FIYUDC)

⚠ WARNING

Hazardous Voltage w/Capacitors!

Failure to disconnect power and discharge capacitors before servicing could result in death or serious injury.

Disconnect all electric power, including remote disconnects and discharge all motor start/run capacitors before servicing. Follow proper lockout/tagout procedures to ensure the power cannot be inadvertently energized. Verify with a CAT III or IV voltmeter rated per NFPA 70E that all capacitors have discharged.

⚠ WARNING

Proper Field Wiring and Grounding Required!

Failure to follow code could result in death or serious injury.

All field wiring MUST be performed by qualified personnel. Improperly installed and grounded field wiring poses FIRE and ELECTROCUTION hazards. To avoid these hazards, you MUST follow requirements for field wiring installation and grounding as described in NEC and your local/state/national electrical codes.

Important: All phases of this installation must comply with NATIONAL, STATE, and LOCAL CODES. In addition to local codes, the installation must comply with National Electric Code - ANSI/NFPA NO. 70 LATEST REVISION.

- Field connections are made by first removing the compressor access panel on the front of the unit. Unscrew the assembly around the outside of the disconnect switch. This assembly is located in the condenser section of the unit.

Both high and low voltage power can be routed through

the base or through the front corner post where the disconnect enclosure is mounted. The hole is sized for 1 1/2-in. conduit.

2. If the conduit required for your application is larger than 1 1/2-in., remove the termination plate and connect to the larger hole using field supplied reducing washers.
3. Route the power wires and ground conductor through conduit and into the bottom of the factory installed disconnect switch. Connect the power conductors to the lugs provided. Connect the ground wire to the unit ground lug.

Note: Wire size for the length of run should be determined using the circuit ampacity found on the unit nameplate and the N.E.C.

4. Route low voltage (class II), control wiring through hole in base of unit but not through high voltage conduit. Feed control wiring through bushing provided on side panel. Route wires through loose wire ties provided.
5. Tighten the wire ties. Secure the excess wire bundle under the wire ties in the outdoor section. Do not leave excess wire in the electrical enclosure. Use the unit wiring diagram to make the low voltage connections.

Figure 30. Field wiring route

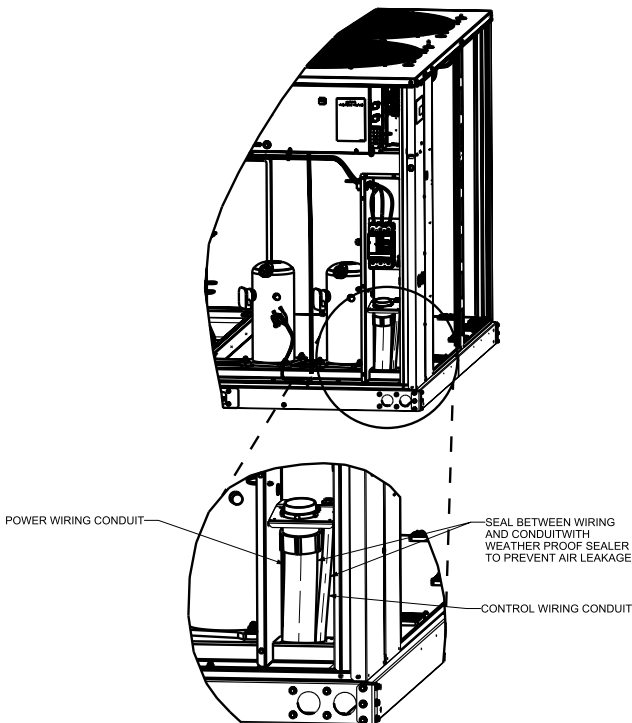

Through the Base Gas Utility Option

This section contains the instructions for making field connections to the Through the Base Gas Utility Option.

Field Installed Connections

⚠ WARNING

Hazardous Voltage w/Capacitors!

Failure to disconnect power and discharge capacitors before servicing could result in death or serious injury.

Disconnect all electric power, including remote disconnects and discharge all motor start/run capacitors before servicing. Follow proper lockout/tagout procedures to ensure the power cannot be inadvertently energized. Verify with a CAT III or IV voltmeter rated per NFPA 70E that all capacitors have discharged.

⚠ WARNING

Proper Field Wiring and Grounding Required!

Failure to follow code could result in death or serious injury.

All field wiring **MUST** be performed by qualified personnel. Improperly installed and grounded field wiring poses **FIRE** and **ELECTROCUTION** hazards. To avoid these hazards, you **MUST** follow requirements for field wiring installation and grounding as described in NEC and your local/state/national electrical codes.

Important: All phases of this installation must comply with **NATIONAL, STATE, and LOCAL CODES**. In absence of local codes, the installation must conform with American National Standard-Z223.1a- National Fuel Gas Code Latest Revision.

1. Field connections are made by first removing the access panel for the heat section on the front of the unit.
2. The gas piping assembly ships inside this section and includes the shut-off valve, a pressure tap for testing, and the necessary unions for field connection. For through the base access, remove the factory-provided cap from the base pan opening. See Figure 31, p. 30.
3. Route field piping through this hole to the dimension shown in Table 6, p. 29 .
4. Place the assembly through the cabinet opening as shown in Table 6, p. 29 and make the union connection to the field piping and to the gas train. Refer to the "Heating Operation (for Gas Units) - Standard Economizer," p. 33 for startup instructions.

Table 6. Through the base gas piping dimension

Model	Dimension
G°C180-300	1 3/16-in.

Figure 31. Through the base gas piping installation

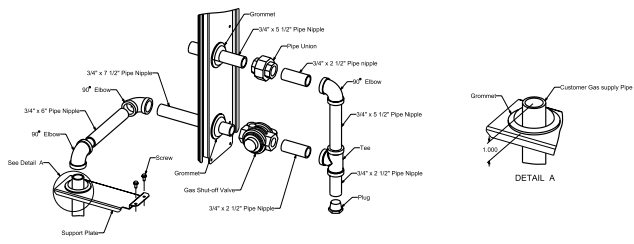

Pre Start

Verifying Proper Air Flow (Units with Belt Drive Indoor Fan)

Much of the systems performance and reliability is closely associated with, and dependent upon having the proper airflow supplied both to the space that is being conditioned and across the evaporator coil.

The indoor fan speed is changed by opening or closing the adjustable motor sheave.

Before starting the SERVICE TEST, set the minimum position setpoint for the economizer to 0% using the setpoint potentiometer located on the Economizer Control (ECA), if applicable.

Electromechanical Controls – Test Procedure

See unit schematic for correct wire numbers.

Fan Test and Minimum Ventilation. Connect red thermostat wire (R) to black thermostat wire (G).

Economizer Cooling. Connect a jumper wire across OAT on Economizer Control (ECA).

Connect red thermostat (R) wire to yellow thermostat wire (Y1).

Cool 1. Connect red thermostat wire (R) to yellow thermostat wire (Y1).

Cool 2. Connect red thermostat wire (R) to yellow thermostat wire (Y2).

Heat 1. Connect red thermostat wire (R) to brown thermostat wire (W1).

Heat 2. Connect red thermostat wire (R) to brown thermostat wire (W2).

Start Up

Electromechanical Controls - Sequence Of Operation

These units are offered with electromechanical controls.

Note: *The Condensate Overflow Switch (COF) (optional) will shut the unit down if the float is raised and the switch is closed.*

Cooling without an Economizer

When the thermostat switch is set to the "Cool" position and the zone temperature rises above the cooling setpoint, the thermostat Y contacts close. The compressor contactor (CC1) coil is energized provided the low pressure control (LPC1), high pressure control (HPC1) and discharge line thermostat (DLT 1) are closed. When the (CC1) contacts close, compressor (CPR1) and both outdoor fan motors (ODM1 and ODM2) start. If the first stage of cooling cannot satisfy the cooling requirement, the thermostat closes Y2. The compressor contactor (CC2) coil is energized provided the low pressure control (LPC2), high pressure control (HPC2) and discharge line thermostat (DLT 2) are closed.

When the (CC2) contacts close, compressor (CPR2) starts.

Evaporator Fan Operation (for Gas Units) - Standard Economizer

When the thermostat fan selection switch is set to the "Auto" position, the Ignition Module (IGN) energizes the indoor fan relay (F) approximately 1 second after energizing the compressor contactor coil (CC1) in the cooling mode. In the heating mode, the Ignition Module (IGN) energizes the indoor fan relay (F) coil approximately 45 second after gas ignition. Closing indoor fan relay (F) coil starts the indoor fan motor (IDM). The (IGN) de-energizes the fan relay (F) approximately 80 seconds after the cooling requirement has been satisfied to enhance unit efficiency.

When the heating cycle is terminated, the indoor fan relay (F) coil is de-energized approximately 90 seconds after the heating requirement.

When the thermostat fan selection switch is set to the "On" position, the (IGN) keeps the indoor fan relay coil (F) energized for continuous fan motor operation.

Evaporator Fan Operation (for Cooling Only Units) - Standard Economizer

When the thermostat fan selection switch is set to the "Auto" position, the thermostat energizes the indoor fan relay coil (F) to start the indoor fan motor (IDM). The fan relay (F) de-energizes after the cooling requirement has been satisfied. When the heating cycle is terminated, the indoor fan relay (F) coil is de-energized with heater contactors.

When the thermostat fan selection switch is set to the "On" position, the thermostat keeps the indoor fan relay coil (F) energized for continuous fan motor operation.

Economizer Set-Up - Standard Economizer

Adjusting the minimum position potentiometer located on the unit economizer module (RTEM-EM) sets the required amount of ventilation air.

Ambient temperature is controlling the economizing cycle by sensing the outside air dry bulb temperature. [Table 7, p. 32](#) lists the selectable dry bulb values by potentiometer setting.

Table 7. Potentiometer settings

Potentiometer Setting	Dry Bulb	Enthalpy
A	27 Btu/lb (63 kJ/kg)	73°F (22.8°C)
B	25 Btu/lb (58 kJ/kg)	70°F (21.1°C)
C ^(a)	23 Btu/lb (53 kJ/kg)	67°F (19.4°C)
D	22 Btu/lb (51 kJ/kg)	63°F (17.2°C)
E	19 Btu/lb (44 kJ/kg)	55°F (12.8°C)

^(a) Factory setting

Cooling with an Economizer - Standard Economizer

The economizer is utilized to control the zone temperature providing the outside air conditions are suitable. Outside air is drawn into the unit through modulating dampers.

When cooling is required and economizing is possible, the unit economizer module (RTEM-EM) opens the economizer damper. The RTEM-EM continues to modulate the economizer damper open/closed to keep the mixed air temperature in the 50°F to 55°F range.

The thermostat will close the Y2 contacts to turn on contactor (CC1) if mechanical cooling is required.

If economizing is not possible, the RTEM-EM drives the damper to the minimum position setpoint when the indoor fan relay (F) is energized and allows mechanical cooling operation.

Heating Operation (Units with Electric Heat) - Standard Economizer

When the system switch is set to the "Heat" position and the zone temperature falls below the heating setpoint, the thermostat closes W1 contacts the first stage electric heat contactor (AH or AH and CH) is energized. If the first stage of electric heat cannot satisfy the heating requirement, the thermostat closes W2.

When the W2 contacts close, the second stage electric heat contactor (BH or BH and DH) is energized, if applicable. The thermostat cycles both the first and second stages of heat "On" and "Off" as required to maintain the zone temperature setpoint.

Heating Operation (for Gas Units) - Standard Economizer

When the system switch is set to the "Heat" position and the zone temperature falls below the heating setpoint, the Ignition module (IGN) initiates a heat cycle.

Ignition Module Low, Medium and High Heat

Two-stage (IGN) runs self-check (including verification that the gas valve is de-energized). (IGN) checks the high-limit switches (TC01 and TC01) for normally closed contacts, the pressure switch (PS) for normally open contacts, and the flame rollout (FR) switch for continuity. (IGN) energizes inducer blower on high speed to check pressure switch closure. If the pressure switch is closed, the inducer blower starts a 20 second pre-purge (15 seconds on high speed followed by 5 seconds on low speed).

If the pressure switch (PS) is still open, the inducer blower will continue to be energized on high speed until pressure switch closure.

After pre-purge completes, the (IGN) energizes the first stage of the gas valve, initiates spark for 2 seconds minimum, 7 seconds maximum (ignition trial) and detects flame and de-energizes spark. From this point, a fixed 45 second indoor blower delay on timing starts.

After the indoor blower delay on is completed, the (IGN) energizes the indoor blower. The (IGN) enters a normal operating loop where all inputs are continuously monitored. If the first stage of gas heat cannot satisfy the heating requirement, the thermostat closes W2. The (IGN) energizes the second stage of the gas valve and the second stage of inducer blower.

When the zone thermostat is satisfied, the (IGN) de-energizes the gas valve. The (IGN) senses loss of flame. The (IGN) initiates a 5 second inducer blower post purge and 90 second indoor blower delay off at current speed. The (IGN) de-energizes the inducer blower at the end of the post purge. The (IGN) de-energizes the indoor blower at the end of the selected indoor blower delay off.

Table 8. Ignition module diagnostics

Steady light	Module is powered up, but no active call for heat.
Blinking at continuous steady rate	Active call for heat.
One blink	Loss of communication.
Two blinks	System lockout (failure to ignite, no spark, low/ no gas pressure, etc.)

Table 8. Ignition module diagnostics (continued)

Three blinks	Pressure switch (no vent air flow, bad CBM, closed at initial call for heat). Auto reset.
Four blinks	High limit (excessive heat in combustion chamber, low airflow). Auto reset.
Five blinks	Flame sensed and gas valve not energized or flame sensed and no call for heat.
Six blinks	Flame rollout (CBM failure, incorrect gas pressure, and incorrect primary air). Requires manual reset of the switch.
Seven blinks	W1 and W2 swapped (electromechanical 3-10 tons units).

Drain Pan Condensate Overflow Switch (Optional)

The Condensate Overflow Switch (COF) is utilized to prevent water overflow from the drain pan. The float switch is installed on the corner lip of the drain pan. When the condensate level reaches the trip point, the COF relay energizes and opens the 24 Vac control circuit which disables the unit. Once the 24 Vac control circuit is opened, a delay timer will prevent unit start-up for three minutes.

Low Ambient Operation (Optional)

During low ambient operation, outside air temperature below 50°F, the Low Ambient Controller will cycle the outdoor fan motor "Off" and "On" based on discharge pressure. The indoor fan motor (IDM) will continue to operate and the outdoor fan will return to normal operation once the ambient temperature is above 50°F.

Two-Speed Indoor Fan Control

For units equipped with two-speed indoor fan control, standard unit operation for cooling and heating will continue and all unit functions will operate normally, except for the control of the indoor fan speed. All units configured with any type of heating will heat the supply air and space as normal utilizing full speed indoor fan by energizing the appropriate outputs. The two-speed indoor fan unit will only utilize two speeds during the cooling operation modes described below.

Cooling Operation

For cooling operation, the unit will operate at Low Fan Speed during Fan Only, Economizer Only, and the first stage of compressor unit modes by Default. When the unit receives a call for cooling, if the economizer is enabled, the unit will energize the associated Low Speed output and begin to modulate the OA Damper open above minimum position up to 100% as necessary. By default, the supply fan will remain at low speed for the duration of Economizer-Only cooling. If the supply fan is on when the first stage compressor is energized, it will remain energized or energize at low speed for the duration of Cool 1.

When there is a call for Cool 2, the second compressor is energized and the Supply Fan will switch to High Speed.

The unit will stage down compressors for cooling in reverse order that they were staged and the supply fan will follow the unit mode transitions. Once it is determined through normal cooling control that the second compressor is no longer necessary to meet cooling demand, the second compressor will be staged back and the supply fan will switch to Low Speed until the unit stages all cooling off or receives a call for Cool 2 again. Once the Supply Fan is no longer requested ON after a Cooling call is cleared, the Supply Fan will remain energized at Low Speed for 60 seconds as on traditional units.

If the economizer is enabled and is being utilized as the first stage of cooling (Y1 active), if the unit receives a Y2 request, the unit will energize the first compressor and will switch the supply fan to high speed until the Y2 request is cleared.

Economizer Minimum Position Handling for 2-Speed Fan

Due to the low and high speeds of the indoor fan, when the unit is in Fan Only, Cool 1, or Economizer Only and the indoor fan is at low speed, the unit will not be bringing in as much fresh air as normal. By setting a higher minimum damper position this problem could be solved, but that would mean more fresh air than may be desired when the supply fan is at high speed. To overcome these situations, the control will require the setting of two economizer minimum positions to be used when the fan is at low and high speed to compensate for the lower amount of fresh air at lower fan speeds and the potential for more fresh air than desired at higher fan speeds. These minimum positions will be obtained from the Bldg Design Min Position and DCV Min Position pots on the RTEM-EM. The economizer minimum position that will be utilized while the supply fan is at low speed will be set with the DCV Min Position pot with a range of 0-100% and the minimum position that will be utilized while the supply fan is at high speed will be set with the Building Design Min Position pot with a range of 0-50%. If the Building Design Min Position is set to be higher than the DCV Min Position, the setpoints will be capped at the DCV Min Position and the setpoint for the min position at low and high fan speed will be the DCV Min Position.

Phase Monitor

The phase monitor is a three-phase line monitor module that protects against phase loss, phase reversal and phase unbalance. It is intended to protect compressors from reverse rotation. It has an operating input voltage range of 180-600 Vac, and LED indicators for ON and FAULT. There

are no field adjustments and the module will automatically reset from a fault condition.

Low Pressure Cutout

The low pressure cutouts are wired in series with the high pressure cutouts and the temperature discharge limits. If this circuit is open before a compressor is started, the compressor in that circuit will not be allowed to operate.

Anytime this circuit is opened, the compressor in that circuit is turned off immediately.

High Pressure Cutout and Temperature Discharge Limit

The high pressure controls and temperature discharge limit are wired in series between the compressor outputs on the LTB and the compressor contactors. If the high pressure safety or temperature discharge limit opens, the compressor on the affected circuit is turned off.

Locking Safety Device with Compressor Anti Short Cycle Timer

This device monitors compressor safety switch trips to prevent short cycling, protecting the compressor. A manual reset is required after a fourth safety switch trip.

Coil Frost Protection

The Frostat™ control monitors the evaporator coil temperature to prevent the evaporator from freezing due to low operating temperatures whenever there is a demand for cooling. When a open circuit has occurred, the Frostat opens the 24 Vac ground and opens all of the cooling contactors.

Heating Operation

Standard unit operation for heating will continue on units equipped with a two-speed indoor fan. During heat mode, all units configured with staged electric or gas heat will heat the supply air and space as normal utilizing full speed indoor fan.

Emergency Stop

This input de-energizes the 24 Vac output from the phase monitor and can be activated by opening a field supplied device connected to the LTB.

JADE Controls - Low Leak Economizer Sequence of Operation

Table 9. Dry bulb operation no DCV (CO₂ sensor) - 2 speed fan

DCV	OA Good to economize?	Y1-I	Y2-I	FAN SPD	Y1-O	Y2-O	Occupied	Unoccupied
None	No	Off	Off	Low	0-v/Off	0-v/Off	MIN POS L	Closed
		On	Off	Low	24-v/On	0-v/Off	MIN POS L	Closed
		On	On	High	24-v/On	24-v/On	MIN POS H	Closed
None	Yes	Off	Off	Low	0-v/Off	0-v/Off	MIN POS L	Closed
		On	Off	Low	0-v/Off	0-v/Off	MIN POS L to Full-Open	Closed to Full-Open
		On	On	High	DELAY 24-v/On ^(a)	0-v/Off ^(b)	MIN POS H to Full-Open	Closed to Full-Open

^(a) With 2SP FAN DELAY (Advanced Setup Menu) when in the economizing mode there is a delay for the high speed fan to try to satisfy the call for second stage cooling by turning on the fan to high and opening the OA damper 100% before the first stage mechanical cooling is enabled.

^(b) With stage 3 delay (STG3 DLY) in Advanced setup menu can turn on 2nd stage of mechanical cooling Y2-O after the delay if the call for Y1-I and Y2-I have not been satisfied.

Table 10. Dry bulb operation with DCV (CO₂ sensor) - 2 speed fan

DCV	OA Good to economize?	Y1-I	Y2-I	FAN SPD	Y1-O	Y2-O	Occupied	Unoccupied
Below set	No	Off	Off	Low	0-v/Off	0-v/Off	VENTMIN L	Closed
		On	Off	Low	24-v/On	0-v/Off	VENTMIN L	Closed
		On	On	High	24-v/On	24-v/On	VENTMIN H	Closed
	Yes	Off	Off	Low	0-v/Off	0-v/Off	VENTMIN L	Closed
		On	Off	Low	0-v/Off	0-v/Off	VENTMIN L to Full-Open	Closed to Full-Open
		On	On	High	24-v/On	0-v/Off ^(a)	VENTMIN H to Full-Open	Closed to Full-Open
Above set	No	Off	Off	Low	0-v/Off	0-v/Off	VENTMIN L to VENTMAX	Closed
		On	Off	Low	24-v/On	0-v/Off	VENTMIN L to VENTMAX	Closed
		On	On	High	24-v/On	24-v/On	VENTMIN H to VENTMAX	Closed
	Yes	Off	Off	Low	0-v/Off	0-v/Off	VENTMIN L to VENTMAX	Closed
		On	Off	Low	0-v/Off	0-v/Off	VENTMIN L to Full-Open	Closed to Full-Open
		On	On	High	DELAY 24-v/On ^(b)	0-v/Off ^(a)	VENTMIN H to Full-Open	Closed to Full-Open

^(a) With stage 3 delay (STG3 DLY) in Advanced setup menu can turn on 2nd stage of mechanical cooling Y2-O after the delay if the call for Y1-I and Y2-I have not been satisfied.

^(b) With 2SP FAN DELAY (Advanced Setup Menu) when in the economizing mode there is a delay for the high speed fan to try to satisfy the call for second stage cooling by turning on the fan to high and opening the OA damper 100% before the first stage mechanical cooling is enabled.

Table 11. Enthalpy operation no DCV (CO₂ sensor) - 2 speed fan

DCV	OA Good to economize?	Y1-I	Y2-I	FAN SPD	Y1-O	Y2-O	Occupied	Unoccupied
NO CO ₂ SENSOR	No	Off	Off	Low	0-v/Off	0-v/Off	MIN POS L	Closed
		On	Off	Low	24-v/On	0-v/Off	MIN POS L	Closed
		On	On	High	24-v/On	24-v/On	MIN POS H	Closed
	Yes	Off	Off	Low	0-v/Off	0-v/Off	MIN POS L	Closed
		On	Off	Low	0-v/Off	0-v/Off	MIN POS L to Full-Open	Closed to Full-Open
		On	On	High	DELAY 24-v/On ^(a)	0-v/Off ^(b)	MIN POS H to Full-Open	Closed to Full-Open

^(a) With 2SP FAN DELAY (Advanced Setup Menu) when in the economizing mode there is a delay for the high speed fan to try to satisfy the call for second stage cooling by turning on the fan to high and opening the OA damper 100% before the first stage mechanical cooling is enabled.

^(b) With stage 3 delay (STG3 DLY) in Advanced setup menu can turn on 2nd stage of mechanical cooling Y2 -O after the delay if the call for Y1-I and Y2-I have not been satisfied.

Start Up

Table 12. Enthalpy operation with DCV (CO₂ sensor) - 2 speed fan

DCV	OA Good to economize?	Y1-I	Y2-I	FAN SPD	Y1-O	Y2-O	Occupied	Unoccupied
Below set	No	Off	Off	Low	0-v/Off	0-v/Off	VENTMIN L	Closed
		On	Off	Low	24-v/On	0-v/Off	VENTMIN L	Closed
		On	On	High	24-v/On	24-v/On	VENTMIN H	Closed
	Yes	Off	Off	Low	0-v/Off	0-v/Off	VENTMIN L	Closed
		On	Off	Low	0-v/Off	0-v/Off	VENTMIN L to Full-Open	Closed to Full-Open
		On	On	High	24-v/On	0-v/Off ^(a)	VENTMIN H to Full-Open	Closed to Full-Open
Above set	No	Off	Off	Low	0-v/Off	0-v/Off	VENTMIN L to VENTMAX	Closed
		On	Off	Low	24-v/On	0-v/Off	VENTMIN L to VENTMAX	Closed
		On	On	High	24-v/On	24-v/On	VENTMIN H to VENTMAX	Closed
	Yes	Off	Off	Low	0-v/Off	0-v/Off	VENTMIN L to VENTMAX	Closed
		On	Off	Low	0-v/Off	0-v/Off	VENTMIN L to Full-Open	Closed to Full-Open
		On	On	High	DELAY 24-v/On ^(b)	0-v/Off ^(a)	VENTMIN H to Full-Open	Closed to Full-Open

^(a) With stage 3 delay (STG3 DLY) in Advanced setup menu can turn on 2nd stage of mechanical cooling Y2-O after the delay if the call for Y1-I and Y2-I have not been satisfied.

^(b) With 2SP FAN DELAY (Advanced Setup Menu) when in the economizing mode there is a delay for the high speed fan to try to satisfy the call for second stage cooling by turning on the fan to high and opening the OA damper 100% before the first stage mechanical cooling is enabled.

Economizer Set-Up

Adjusting the minimum position (MIN POS/VENTMAX on the SETPOINTS menu) sets the required amount of ventilation air.

Ambient temperature controls the economizing cycle by sensing the outside air dry bulb temperature. [Table 13, p. 36](#) lists the five selectable dry bulb values (ENTH CURVE) on the SETPOINTS menu.

Table 13. Single enthalpy and dual enthalpy boundaries (parameters ES1 through ES5)

Enth. Curve	Temp. dry-Bulb (°F)	Temp. dewpoint (°F)	Enthalpy (btu/lb/da)	Point P1		Point P2	
				Temp. °F	Humid.% RH	Temp. °F	Humid.% RH
ES1	80.0	60.0	28.0	80.0	36.8	66.3	80.1
ES2	75.0	57.0	26.0	75.0	39.6	63.3	80.0
ES3	70.0	54.0	24.0	70.0	42.3	59.7	81.4
ES4	65.0	51.0	22.0	65.0	44.8	55.7	84.2
ES5	60.0	48.0	20.0	60.0	46.9	51.3	88.5
HL	86.0	66.0	32.4	86.0	38.9	72.4	80.3

Note: For differential enthalpy there is a high limit boundary. The high limit boundary is ES1 when there are no stages of mechanical cooling energized and HL when a compressor stage is energized.

Note: To disable the economizer to do functional testing, use a 10 mm wrench to completely unsecure the shaft coupling. After testing, tighten shaft coupling securely onto damper shaft using minimum 120 lb-in. (13.6 Nm) to maximum 180 lb-in. (20.3 Nm) torque.

Drain Pan Condensate Overflow Switch (Optional)

The Condensate Overflow Switch (COF) is utilized to prevent water overflow from the drain pan. The float switch is installed on the corner lip of the drain pan. When the condensate level reaches the trip point, the COF relay energizes and opens the 24 Vac control circuit which disables the unit. Once the 24 Vac control circuit is opened, a delay timer will prevent unit start-up for three minutes.

Low Ambient Operation (Optional)

During low ambient operation, outside air temperature below 50°F, the Low Ambient Controller will cycle the outdoor fan motor "Off" and "On" based on discharge pressure. The indoor fan motor (IDM) will continue to operate and the outdoor fan will return to normal operation once the ambient temperature is above 50°F.

Two-Speed Indoor Fan Control

The JADE controller does not control the supply directly but uses the following input status to determine the speed of the supply fan and controls the OA damper to the required position.

The W (heating mode) is not controlled by the controller but it requires the status to know where to position the OA damper for minimum position for the fan speed.

The 2-speed fan delay is available when FAN SPEED is set to 2-speed on the System Setup menu.

The 2-speed fan delay is defaulted to 5 minutes and can be changed in the Advanced Setup menu (2SP FAN DELAY). When the unit has a call for Y1 In and in the free cooling mode and there is a call for Y2 In, the 2-speed fan delay starts and the OA damper will modulate 100% open, the supply fan should be set to high speed by the unit controller. After the delay one of two actions will happen:

- The Y2 In call will be satisfied with the damper 100% open and fan on high speed and the call will turn off.
- OR
- If the call for additional cooling in the space has not been satisfied then the first stage of mechanical cooling will be enabled through Y1 Out or Y2 Out.

Phase Monitor

The phase monitor is a three-phase line monitor module that protects against phase loss, phase reversal and phase unbalance. It is intended to protect compressors from reverse rotation. It has an operating input voltage range of 180-600 Vac, and LED indicators for ON and FAULT. There are no field adjustments and the module will automatically reset from a fault condition.

Low Pressure Cutout

The low pressure cutouts are wired in series with the high pressure cutouts and the temperature discharge limits. If this circuit is open before a compressor is started, the compressor in that circuit will not be allowed to operate.

Anytime this circuit is opened, the compressor in that circuit is turned off immediately.

High Pressure Cutout and Temperature Discharge Limit

The high pressure controls and temperature discharge limit are wired in series between the compressor outputs on the LTB and the compressor contactors. If the high pressure safety or temperature discharge limit opens, the compressor on the affected circuit is turned off.

Coil Frost Protection

The Frostat™ control monitors the evaporator coil temperature to prevent the evaporator from freezing due to low operating temperatures whenever there is a demand for cooling. When a open circuit has occurred, the Frostat opens the 24 Vac ground and opens all of the cooling contactors.

Initiation of Operating Modes

The JADE controller is able to initiate the following modes: Compressor, Economizer, Fans, Heating System, and Cooling System.

The Compressor mode is initiated by either the OAT going above the DRYBLB SET setting or by the thermostat initiating a call to cool when the damper is at 100% open. The Economizer mode is controlled by the MAT getting above the MAT SET setting while the OAT is below the DRYBLB SET setting. While the fans are not controlled by the controller, the Fan mode is dependent on what state the system is in (OCC or Y1 states will cause the damper to go to a LOW fan speed damper setting, while Y2 or W states will cause the controller to open the damper to the HIGH fan speed damper setting). The Heating System mode requires an input to the AUX2-1 terminal from the thermostat, and the Cooling System mode requires an input to the Y2 IN and/or the Y1 IN terminals from the thermostat.

Fault Detection and Diagnostics (FDD) Certification

The JADE controller is a certified FDD product (HJW10) by California Title 24, Part 6.

Standard Economizer Start-Up

1. Set the minimum position setpoint for the economizer to the required percentage of minimum ventilation using the setpoint potentiometer located on the Economizer Control (ECA).

The economizer will drive to its minimum position setpoint, exhaust fans (if applicable) may start at random, and the supply fan will start when the SERVICE TEST is initiated.

The Exhaust Fan will start anytime the economizer damper position is equal to or greater than the exhaust fan setpoint.

2. Verify that the dampers stroked to the minimum position.
3. Verify that the dampers stroked to the full open position.
4. To stop the SERVICE TEST, turn the main power disconnect switch to the "Off" position or proceed to the next component start-up procedure. Remove electro mechanical test mode connections (if applicable).

LLE Controls Test Procedure

See unit schematic for correct wire numbers.

Use the CHECKOUT menu in the Installation Instructions (ACC-SVN178*-EN) to test the damper operation and any configured outputs. Only items that are configured are shown in the Checkout menu.

To Perform Checkout Tests:

1. Scroll to the desired test in the checkout menu using

Start Up

the Δ and ∇ buttons.

2. Press the \leftarrow button to select the item.
3. "RUN?" is displayed.
4. Press \leftarrow to start the test.
5. The unit pauses and then displays "IN PROGRESS".
6. When the test is complete, "DONE" appears.
7. When all parameters have been tested, press \oplus (Menu Up) to end the test (e.g. turn off the relay).

Notes:

- *The checkout tests can all be performed at the time of installation or any time during the operation of the system.*
- *JADE will be in "set up" mode for the first 60 minutes after powered. If OA sensor or Sylk Bus device (sensor or actuator) is disconnected during the set up mode, the JADE will not alarm that failure. The MA sensor is a system "critical" sensor, if the MA sensor is removed during the set up mode, the JADE will alarm. After 60 minutes the JADE controller will change to operation mode and all components removed or failed will alarm in the operation mode.*
- *Upon power up (or after a power outage or brownout), the JADE controller module begins a 5 minute power up delay before enabling mechanical cooling.*

Compressor Start-Up

1. Attach a set of service gauges onto the suction and discharge gauge ports for each circuit. Refer to the refrigerant circuit illustration in the Service Facts. See, "Cooling Operation," p. 33 for startup instructions.

Scroll Compressors

- a. Once each compressor has started, verify that the rotation is correct. If wired correctly the suction pressure should drop and the discharge pressure should rise. If a scroll compressor is rotating backwards, it will not pump and a loud rattling sound can be observed.
- b. If the electrical phasing is correct, before condemning a compressor, interchange any two leads (at the compressor Terminal block) to check the internal phasing. Refer to the following illustration for the compressor terminal/phase identification. Do not allow the compressor to operate backwards for more than 5 seconds. Operation for a period of time longer than this will result in compressor damage.

Note: Copeland ZP scroll compressors for R410A units use Trane OIL00094. Compressor types and appropriate oil charge is listed in the following tables.

Table 14. Compressor types

Tonnage	Compressor 1	Compressor 2
GCC180	CSHW082J0	CSHW073J0
GCC210	CSHW089J0	CSHW089J0
GCC240	ZP122KCE	ZP104KCE
GCC300	ZP137KCE	ZP122KCE

Table 15. POE Oil recharge amount (fl. oz.)

Tonnage	Compressor 1	Compressor 2
GCC180	61	52
GCC210	61	61
GCC240	81	81
GCC300	106	81

Heating Start-Up

Using the Service Test Guide perform the proper test mode connections.

When starting the unit for the first time or servicing the heaters, it is a good practice to start the heater with the main gas supply turned "Off". Once the ignition system and components have been checked, open the main power disconnect switch to reset the unit.

Final System Set Up

After completing all of the pre-start and startup procedures outlined in the previous sections (i.e., operating the unit in each of its modes through all available stages of cooling and heating), perform these final checks before leaving the unit:

- Program the Night Setback (NSB) panel (if applicable) for proper unoccupied operation. Refer to the programming instructions for the specific panel.
- Verify that the Remote panel "System" selection switch, "Fan" selection switch, and "Zone Temperature" settings for automatic operation are correct.
- Inspect the unit for misplaced tools, hardware, and debris.
- Verify that all exterior panels including the control panel doors and condenser grilles are secured in place.
- Close the main disconnect switch or circuit protector switch that provides the supply power to the unit's terminal block or the unit mounted disconnect switch.

Maintenance

Make sure all personnel are standing clear of the unit before proceeding. The system components will start when the power is applied.

Fan Belt Adjustment-Belt Drive Units

⚠ WARNING

Rotating Components!
Failure to disconnect power before servicing could result in rotating components cutting and slashing technician which could result in death or serious injury.
Disconnect all electric power, including remote disconnects before servicing. Follow proper lockout/tagout procedures to ensure the power can not be inadvertently energized.

The fan belts must be inspected periodically to assure proper unit operation. Replacement is necessary if the belts appear frayed or worn. Units with dual belts require a matched set of belts to ensure equal belt length.

When removing or installing the new belts, do not stretch them over the sheaves. Loosen the belts using the belt tension adjustment bolts on the motor mounting base.

Once the new belts are installed, using a Browning or Gates tension gauge (or equivalent), adjust the belt tension as follows:

1. To determine the appropriate belt deflection:
 - a. Measure the center-to-center shaft distance (in inches) between the fan and motor sheaves.
 - b. Divide the distance measured in Step 1a by 64; the resulting value represents the amount of belt deflection that corresponds to the proper belt tension.
2. Set the large O-ring on the belt tension gauge at the

- deflection value determined in [Step 1b](#).
3. Set the small O-ring at zero on the force scale of the gauge plunger.
4. Place the large end of the gauge at the center of the belt span; then depress the gauge plunger until the large O-ring is even with the top of the next belt or even with a straightedge placed across the fan and motor sheaves.
5. Remove the belt tension gauge. The small O-ring now indicates a number other than zero on the plunger's force scale. This number represents the force (in pounds) required to give the needed deflection.
6. Compare the "force" scale reading (Step 5) with the appropriate "force" value listed in the Belt tension table. If the "force" reading is outside the range, readjust the belt tension.

Note: Actual belt deflection "force" must not exceed the maximum "force" value shown in the Belt tension measurement and deflection ranges table.
7. Recheck the belt tension at least twice during the first 2 to 3 days of operation. Belt tension may decrease until the new belts are "run in".

Figure 32. Belt tension gauge

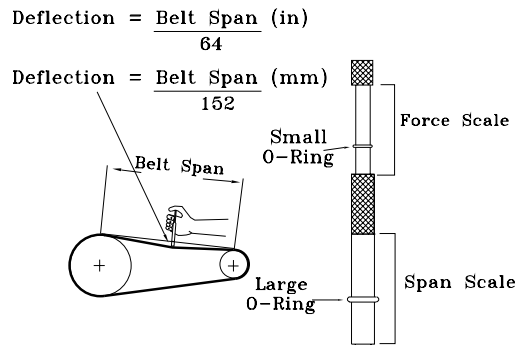

Table 16. Belt tension measurement and deflection ranges (in/lb)

Belts Cross Section	Small P.D Range (in)	Deflection Force (lb)					
		Super Gripbelts (in)		Gripnotch (in)		Steel Cable Gripbelts (in)	
		Min.	Max.	Min.	Max.	Min.	Max.
A	3.0-3.6	3.00	4.50	3.87	5.50	3.25	4.00
	3.8-4.8	3.50	5.00	4.50	6.25	3.75	4.75
	5.0-7.0	4.00	5.50	5.00	6.87	4.25	5.25
B	3.4-4.2	4.00	5.50	5.75	8.00	4.50	5.50
	4.4-5.6	5.12	7.12	6.50	9.12	5.75	7.25
	5.8-8.8	6.37	8.75	7.37	10.12	7.00	8.75

Table 17. Belt tension measurement and deflection ranges (mm/kg)

Belts Cross Section	Small P.D Range (mm)	Deflection Force (kg)					
		Super Gripbelts (mm)		Gripnotch (mm)		Steel Cable Gripbelts (mm)	
		Min.	Max.	Min.	Max.	Min.	Max.
A	13.3–16.0	13.3	20.0	17.2	24.5	14.5	17.8
	16.9–21.4	15.6	22.2	20.0	27.8	16.7	21.1
	22.0–31.1	17.8	24.5	22.2	30.6	18.9	23.4
B	15.1–18.7	17.8	24.5	25.6	35.6	20.0	24.5
	19.6–24.9	22.8	31.7	28.9	40.6	25.6	32.3
	25.8–39.1	28.4	38.9	32.8	45.0	31.1	38.9

Monthly Maintenance

Before completing the following checks, turn the unit OFF and lock the main power disconnect switch open.

⚠ WARNING

Hazardous Voltage!

Failure to disconnect power before servicing could result in death or serious injury.

Disconnect all electric power, including remote disconnects before servicing. Follow proper lockout/tagout procedures to ensure the power can not be inadvertently energized. Verify that no power is present with a voltmeter.

Filters

Inspect the return air filters. Clean or replace them if necessary. Refer to the unit Service Facts for filter information.

Condensate Overflow Switch

During maintenance, the switch float (black ring) must be checked to ensure free movement up and down.

Cooling Season

- Check the unit's drain pans and condensate piping to ensure that there are no blockages.
- Inspect the evaporator and condenser coils for dirt, bent fins, etc. If the coils appear dirty, clean them according to the instructions described in "Coil Cleaning" later in this section.
- Manually rotate the condenser fans to ensure free movement and check motor bearings for wear. Verify that all of the fan mounting hardware is tight.
- Inspect the F/A-R/A damper hinges and pins to ensure that all moving parts are securely mounted. Keep the blades clean as necessary.

⚠ WARNING

Rotating Components!

Failure to disconnect power before servicing could result in rotating components cutting and slashing technician which could result in death or serious injury.

During installation, testing, servicing and troubleshooting of this product it may be necessary to work with live and exposed rotating components. Have a qualified or licensed service individual who has been properly trained in handling exposed rotating components, perform these tasks.

NOTICE

Equipment Damage!

Forcibly turning the motor shaft can damage the gear train and motor beyond repair.

Never turn the motor shaft by hand or with a wrench.

- Verify that all damper linkages move freely; lubricate with white grease, if necessary.
- Check supply fan motor bearings; repair or replace the motor as necessary.
- Check the fan shaft bearings for wear. Replace the bearings as necessary.
- Check the supply fan belt(s). If the belts are frayed or worn, replace them. Refer to the "Fan Belt Adjustment-Belt Drive Units," p. 39 for belt replacement and adjustments.
- Verify that all wire terminal connections are tight.
- Remove any corrosion present on the exterior surfaces of the unit and repaint these areas.
- Generally inspect the unit for unusual conditions (e.g., loose access panels, leaking piping connections, etc.)
- Make sure that all retaining screws are reinstalled in the unit access panels once these checks are complete.
- With the unit running, check and record the following:

- ambient temperature
- compressor oil level (each circuit)
- compressor suction and discharge pressures (each circuit)
- superheat and subcooling (each circuit)

Record this data on an “operator’s maintenance log” like the one shown in Sample maintenance log table in Final Process Section. If the operating pressures indicate a refrigerant shortage, measure the system superheat and system subcooling. For guidelines, refer to “Compressor Start-Up,” p. .

Important: *Do not release refrigerant to the atmosphere! If adding or removing refrigerant is required, the service technician must comply with all federal, state and local laws. Refer to general service bulletin MSCU-SB-1 (latest edition).*

Heating Season

- Inspect the unit’s air filters. If necessary, clean or replace them.
- Check supply fan motor bearings; repair or replace the motor as necessary.
- Inspect both the main unit control panel and heat section control box for loose electrical components and terminal connections, as well as damaged wire insulation. Make any necessary repairs.
- Verify that the electric heat system operates properly.

Coil Cleaning

Regular coil maintenance, including annual cleaning enhances the unit’s operating efficiency by minimizing the following:

- Compressor head pressure and amperage draw
- Evaporator water carryover
- Fan brake horsepower
- Static pressure losses
- Airflow reduction

At least once each year, or more often if the unit is located in a “dirty” environment, clean the condenser coils using the instructions outlined below. Be sure to follow these instructions as closely as possible to avoid damaging the coils.

⚠ WARNING

Hazardous Chemicals!

Failure to follow this safety precaution could result in death or serious injury. Coil cleaning agents can be either acidic or highly alkaline and can burn severely if contact with skin or eyes occurs.

Handle chemical carefully and avoid contact with skin. **ALWAYS** wear Personal Protective Equipment (PPE) including goggles or face shield, chemical resistant gloves, boots, apron or suit as required. For personal safety refer to the cleaning agent manufacturer’s Materials Safety Data Sheet and follow all recommended safe handling practices.

Microchannel (MCHE) Coils

NOTICE

Coil Damage!

Failure to follow instructions below could result in coil damage.

DO NOT use any detergents with microchannel condenser coils.

Use pressurized water or air **ONLY**, with pressure no greater than 600psi.

For additional information regarding the proper microchannel coil cleaning procedure, refer to RT-SVB83-EN*

Due to the soft material and thin walls of the MCHE coils, the traditional field maintenance method recommended for Round Tube Plate Fin (RTPF) coils does not apply to microchannel coils. Moreover, chemical cleaners are a risk factor to MCHE due to the material of the coil. The manufacturer does not recommend the use of chemical cleaners to clean microchannel coils. Using chemical cleaners could lead to warranty claims being further evaluated for validity and failure analysis.

The recommended cleaning method for microchannel condenser coils is pressurized water or air with a non-pinpoint nozzle and an ECU of at least 180 with pressure no greater than 600 psi. To minimize the risk of coil damage, approach the cleaning of the coil with the pressure washer aimed perpendicular to the face of the coil during cleaning. Optimum clearance between the sprayer nozzle and the microchannel coil is 1”–3”.

Final Process

For future reference, record the unit data below in the blanks provided.

Table 18. Unit data log

Complete Unit Model Number	
Unit Serial Number	
Wiring Diagram Numbers (from unit control panel)	

Maintenance

Table 18. Unit data log (continued)

-schematic(s)	
-connections	
Network ID	

Table 19. Sample maintenance log

Date	Current Ambient Temp F/C	Refrigerant Circuit #1						Refrigerant Circuit #2						
		Compr. Oil Level	Suct. Press. Psig/kPa	Disch. Press. Psig/kPa	Liquid Press. Psig/kPa	Superheat F/C	Sub-cool F/C	Compr. Oil Level	Suct. Press. Psig/kPa	Disch. Press. Psig/kPa	Liquid Press. Psig/kPa	Superheat F/C	Sub-cool F/C	
		- ok - low						- ok - low						
		- ok - low						- ok - low						
		- ok - low						- ok - low						
		- ok - low						- ok - low						
		- ok - low						- ok - low						
		- ok - low						- ok - low						
		- ok - low						- ok - low						
		- ok - low						- ok - low						
		- ok - low						- ok - low						
		- ok - low						- ok - low						
		- ok - low						- ok - low						
		- ok - low						- ok - low						
		- ok - low						- ok - low						
		- ok - low						- ok - low						
		- ok - low						- ok - low						
		- ok - low						- ok - low						

Troubleshooting

⚠ WARNING

Hazardous Service Procedures!

Failure to follow all precautions in this manual and on the tags, stickers, and labels could result in death or serious injury.

Technicians, in order to protect themselves from potential electrical, mechanical, and chemical hazards, **MUST** follow precautions in this manual and on the tags, stickers, and labels, as well as the following instructions: Unless specified otherwise, disconnect all electrical power including remote disconnect and discharge all energy storing devices such as capacitors before servicing. Follow proper lockout/tagout procedures to ensure the power can not be inadvertently energized. When necessary to work with live electrical components, have a qualified licensed electrician or other individual who has been trained in handling live electrical components perform these tasks.

Standard Troubleshooting

Ignition Module

The Ignition Module (IGN) has the ability to provide the service personnel with some unit diagnostics and system status information.

Before turning the main power disconnect switch “Off”, follow the steps below to check the IGN.

To prevent injury or death from electrocution, it is the responsibility of the technician to recognize this hazard and use extreme care when performing service procedures with the electrical power energized.

1. Verify LED on face of the phase monitor is green. If LED is red, correct supply power fault.
2. Verify that the LED on the IGN is burning continuously. If the LED is lit, go to Step 4.
3. If the LED is not lit, verify that 24 Vac is present between R and B. If the LED is not lit and 24 Vac is present replace the IGN. If 24 Vac is not present, check transformer (TNS1). Proceed to Step 4 if necessary.
4. If no failures are indicated, use the TEST mode procedures described in the “Unit Start-Up” section or thermostat to start the unit. This procedure will allow you to check all of the external controls (relays, contactors, etc) and the IGN.
5. Test the system through all of the available modes, and verify operation of all outputs, controls, and modes. Refer to the sequence of operations for each mode, to assist in verifying proper operation. Make the necessary repairs and proceed to Step 6 and Step 7.
6. If no abnormal operating conditions appear in the test mode, exit the test mode by turning the power “Off” at

the main power disconnect switch and removing the test mode connections.

7. Refer to the individual component test procedures if other components are suspect.

Failures

Heating Failure

Verify Heat Failure by Ignition Module (IGN) LED indicator:

OFF: No Power or Failure

Continued ON: No Communication

Slow Flash: Normal, Heat Call

Fast Flash: Error Code:

1 Flash: System Lockout

2 Flash: Pressure Switch Fail

3 Flash: Primary Limit Open

4 Flash: Flame detected when gas valve is not open

5 Flash: Flame Rollout Open

6 Flash: W2 signal but no W1 signal

Cooling Failure

1. Cooling and heating set points (slide pot) on the thermostat have failed.

Note: *Not used on electromechanical units.*

2. CC1 or CC2 24 Vac control circuit has opened. Check CC1 and CC2 coils and Froststat™ status. Check the status of the LED indicator in LSD:
 - a. LED will be flashing to indicate that a Safety Input has opened while a Y call is present.
 - b. Compressor lockout is indicated by a solid (nonflashing) red LED.

To reset LSD - Power cycle on ‘R’ input.

Simultaneous Heat and Cool Failure

Emergency Stop is activated.

Low Leak Economizer – (LLE) Troubleshooting

1. The economizer controller provides alarm messages that display on the 2-line LCD. If one or more alarms are present and there has been no keypad activity for at least 5 minutes, the Alarms menu displays and cycles through the active alarms.



Note: *Note: You can also navigate to the Alarms menu at any time.*

2. Once the alarm has been identified and the cause has been removed (for example, replaced faulty sensor), the alarm can be cleared from the display.

Note: If an alarm still exists after you clear it, it re-displays within 5 seconds.

To Clear an Alarm

Once the alarm has been identified and the cause has been removed (for example, replaced faulty sensor), the alarm can be cleared from the display.

1. Navigate to the desired alarm.
2. Press .
3. "ERASE?" is displayed.
4. Press .
5. "ALARM ERASED" is displayed.
6. Press  (Menu Up) to complete the action and return to the previous menu.

Note: If an alarm still exists after you clear it, it re-displays within 5 seconds.

Low Leak Economizer Fault Codes

Low Leak Economizer Alarms:

- CO₂ Sensor Error

Table 20. FDD troubleshooting

TESTS	FAULTS				
	Air temp. sensor failure / fault	Not economizing when it should	Economizing when it should not	Damper not modulating	Excess outdoor air
Damper Stuck Open			x	x	x
Damper Stuck at Minimum		x		x	
Bad or Unplugged Actuator		x	x	x	
Sensor Hard Failure	x	x	x		x
Actuator Mechanically Disconnected		x	x	x	x

Resetting Cooling and Heating Lockouts

Cooling Failures and Heating Lockouts are reset in an identical manner.

Method 1 section explains resetting the system from the space; Method 2 section explains resetting the system at the unit.

Note: Before resetting Cooling Failures and Heating Lockouts check the Failure Status Diagnostics by the methods previously explained. Diagnostics will be lost when the power to the unit is disconnected.

Method 1

To reset the system from the space, turn the "Mode" selection switch at the thermostat to the "Off" position. After approximately 30 seconds, turn the "Mode" selection switch to the desired mode, i.e. Heat, Cool or Auto.

- SYS Alarm
- Actuator Undervoltage
- Actuator Overvoltage
- Actuator Stalled

The FDD system shall detect the following faults:

- Air temperature sensor failure/fault
- Not economizing when it should
- Economizing when it should not
- Damper not modulating
- Excess outdoor air

The JADE controller is a certified FDD product (HJW10) by California Title 24, Part 6. The FDD system is required for meeting California Energy Commission's Title 24 regulations. Table 20, p. 45 shows the various tests that can be performed (rows) and the five faults that are defined by FDD (columns). The 'x' means that the test has to be conducted to see if it is causing the fault to occur.

Method 2

To reset the system at the unit, cycle the unit power by turning the disconnect switch "Off" and then "On".

Condensate Overflow Switch

When the condensate overflow switch is closed, a drain pan overflow condition is indicated and it will shut unit operations down.

Unit Economizer Control (ECA)

Verify Economizer Status by Economizer Actuator (ECA) LED indicator:

- OFF: No Power or Failure
- ON: Normal, OK to Economize
- Slow Flash: Normal, Not OK to Economize
- Fast Flash - 1/4 Second On / 2 Seconds Off:
 - Error Code: Communications Failure

Troubleshooting

- Pulse Flash: 1/30 Second On / 1/4 Second Off: (2 Seconds between pulse sequences)

Error Code

- 1 Flash: Actuator Fault
- 2 Flashes: CO₂ Sensor
- 3 Flashes: RA Humidity Sensor
- 4 Flashes: RA Temp Sensor
- 6 Flashes: OA Humidity Sensor
- 7 Flashes: OA Temp Sensor
- 8 Flashes: MA Temp Sensor
- 9 Flashes: On-board Setpoint Failure

Wiring Diagrams

Note: Wiring diagrams can be accessed via e-Library by entering the diagram number in the literature order

number search field or by contacting technical support.

Table 21. Wiring diagrams

Type of Airflow	Schematic Type	Voltage	Diagram Number	Description
Multi-Speed Fans	Power	208-230	12134575	Schematic, PWR-EM, 208V-230V, 2-Stage GH with VFD - 15T-25T
		460-575	12134576	Schematic, PWR-EM, 460V/575V, 2-Stage GH with VFD - 15T-25T
	Control	208-575	12134572	GCC180-300, 60Hz, 2-Stage Gas Heat w/VFD
All	Device Location	208-575	12134601	GCC180-300, 60Hz, VFD/Gas Heat

Warranty

For Commercial Unitary Equipment Rated 25 Tons and Under and Related Accessories

Products Covered — This warranty is extended by Trane, and applies to the following products:

- All packaged and split system air conditioners and heat pumps have a rated capacity of 25 tons and under.
- All packaged combinations gas/electric air conditioners having a rated capacity of 25 tons and under.
- All packaged combination gas/electric air conditioners having a rated capacity of 1.5 through 5 tons single phase electric power and used for commercial applications. (As used in this warranty, a commercial application is any application where the end purchaser uses the product for other than personal, family or household purposes.)
- All accessories for the above products which are sold by Trane and applied in accordance with Trane specifications.

Basic Warranty

The warrantor warrants for a period of twelve (12) months from the initial start-up or eighteen (18) months from date of shipment, whichever is sooner, that the products covered by this warranty (1) are free from defects in material and manufacture, and (2) have the capacities and ratings set forth in the warrantor's catalogs and bulletins. If any part of your air conditioner fails because of a manufacturing defect, Warrantor will furnish without charge the required replacement part.

If the heat exchanger fails because of a manufacturing defect within five years from the date of start-up, Warrantor will furnish without charge a replacement heat exchanger. In addition, if the optional, factory installed, stainless steel heat exchanger fails because of a manufacturing defect within ten years from the date of start-up, Warrantor will furnish without charge a replacement heat exchanger.

Any local transportation, related service labor and diagnosis calls are not included. In addition, if the sealed motor-compressor fails because of a manufacturing defect within the second through fifth year from the date of original purchase, Warrantor will furnish without charge the required replacement compressor.

Exclusions and Limitations

The warrantor's obligations and liabilities under this warranty are limited to furnishing F.O.B. factory or

warehouse at the warrantor-designated shipping point, freight allowed to Buyer's city (or port of export for shipments outside the conterminous United States) a replacement product or, at the option of the warrantor, parts for the repair of the product not conforming to this warranty and which have been returned to the warrantor.

The warrantor's warranty is conditional on the Customer providing written notice to the warrantor within thirty (30) days of the discovery of the defect. No product shall be returned to the warrantor without the warrantor's written permission. No liability whatever shall attach to warrantor until said products have been fully paid for and then said liability shall be limited to the purchase price of the equipment shown to be defective.

The warranty does not apply to any compressor or gas-fired heat exchanger which has been repaired or altered in such manner as, in the judgement of the warrantor, affects its stability or reliability. This warranty does not cover (1) any heat exchanger which has been fired with an improper type of fuel (2) a heat exchanger which is installed in a beauty parlor, dry cleaning establishment, de-greasing plant or in any corrosive atmosphere; or (3) any heat exchanger which is not shown to be defective by the warrantor's inspection.

This warranty does not cover damage due to accident, abuse, improper use, external causes, freezing, corrosion, erosion or deterioration. Local transportation, related service labor, air filters, diagnosis calls, refrigerant and related items are not covered.

THE WARRANTY AND LIABILITY SET FORTH HEREIN ARE IN LIEU OF ALL OTHER WARRANTIES AND LIABILITIES, WHETHER IN CONTRACT OR IN NEGLIGENCE, EXPRESS OR IMPLIED, IN LAW OR IN FACT, INCLUDING IMPLIED WARRANTIES OR MERCHANTABILITY AND FITNESS FOR A PARTICULAR PURPOSE AND ANY IMPLIED WARRANTIES OTHERWISE ARISING FROM THE COURSE OF DEALING OR TRADE. IN NO EVENT SHALL THE WARRANTOR BE LIABLE FOR ANY INCIDENTAL OR CONSEQUENTIAL DAMAGES.

The warrantor makes certain further warranty protection available on an optional, extra-cost basis. Any further warranty must be in writing. If you wish further help or information concerning this warranty, contact: Trane — Warrantor, 2701 Wilma Rudolph Blvd., Clarksville, TN 37040

Trane and American Standard create comfortable, energy efficient indoor environments for commercial and residential applications. For more information, please visit trane.com or americanstandardair.com.

Trane and American Standard have a policy of continuous product and product data improvement and reserve the right to change design and specifications without notice. We are committed to using environmentally conscious print practices.

RT-SVX51L-EN 03 Dec 2022
Supersedes RT-SVX51K-EN (April 2022)

©2022