

OUTDOOR UNIT

PARTS CATALOG

No. OBB516
REVISED EDITION-G

Models

MUZ-GE25VA - E1

MUZ-GE25VA - E2

MUZ-GE25VAH - E1

MUZ-GE35VA - E1

MUZ-GE35VA - E2

MUZ-GE35VAH - E1

MUZ-GE35VAH - E2

MUZ-GE42VA - E1

MUZ-GE42VAH - E1

MUZ-GE50VA - E1

MUZ-GE50VAH - E1

MUZ-GE60VA - E1

MUZ-GE71VA - E1

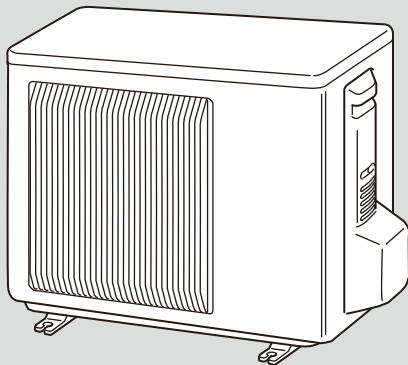

MUZ-GE25VA
MUZ-GE35VA
MUZ-GE42VA

CONTENTS

1. SERVICE PARTS LIST.....2

SERVICE MANUAL (OBH516)

Revision A:

• MUZ-GE42VA - [E1], MUZ-GE42VAH - [E1], MUZ-GE50VA - [E1] and MUZ-GE50VAH - [E1] have been added.

Revision B:

• MUZ-GE60VA - [E1] and MUZ-GE71VA - [E1] have been added.

Revision C:

• Part numbers of reactors for MUZ-GE60VA - [E1] and MUZ-GE71VA - [E1] have been changed. (E12 851 337 → E12 F28 337)

Revision D:

• The fan guards for MUZ-GE50VA(H) - [E1], MUZ-GE60VA - [E1] and MUZ-GE71VA - [E1] have been changed.

Revision E:

• MUZ-GE25VA - [E2], MUZ-GE35VA - [E2] and MUZ-GE35VAH - [E2] have been added.

Revision F:

• Outdoor heat exchanger and inverter P.C. board for MUZ-GE60/71VA - [E1] have been changed.
• Compressor for MUZ-GE71VA - [E1] has been changed.

Revision G:

• Some descriptions have been modified.

1 SERVICE PARTS LIST

MUZ-GE25VA MUZ-GE35VA MUZ-GE42VA

1-1. OUTDOOR UNIT STRUCTURAL PARTS AND FUNCTIONAL PARTS

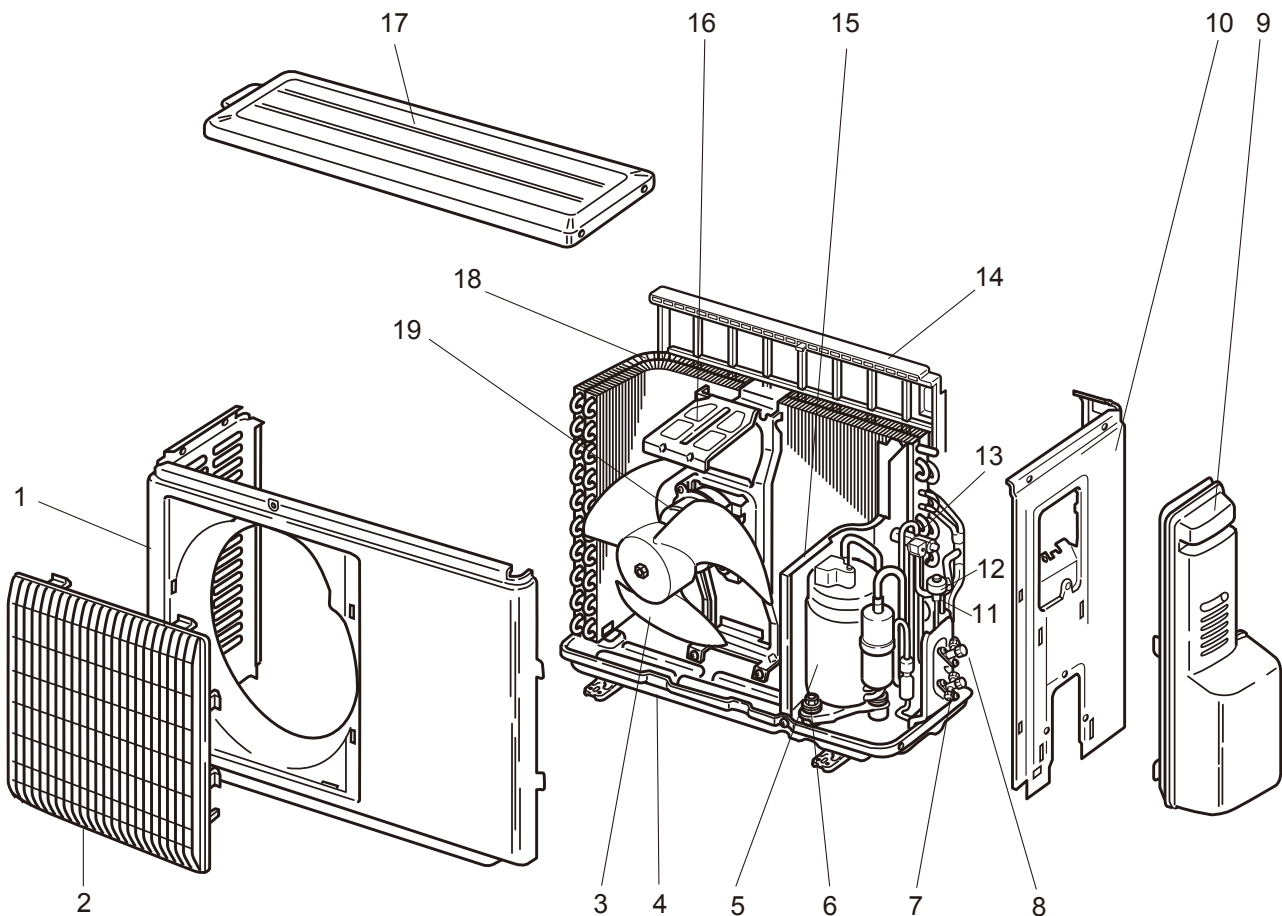

1-1. OUTDOOR UNIT STRUCTURAL PARTS AND FUNCTIONAL PARTS

Part numbers that are circled are not shown in the illustration.

No.	Part No.	Part Name	Symbol in Wiring Diagram	Q'ty/unit					Remarks
				MUZ-GE25		MUZ-GE35		MUZ-GE42	
				VA-[E1]	VA-[E2]	VA-[E1]	VA-[E2]	VA-[E1]	
1	E22 927 232	CABINET		1	1	1	1	1	
2	E22 927 521	GRILLE		1	1	1	1	1	
3	E22 927 501	PROPELLER FAN		1	1	1	1	1	
4	E22 D69 290	BASE		1	1	1	1	1	
5	E22 D69 900	COMPRESSOR	MC	1					KNB073FFDHC
	E22 J13 900	COMPRESSOR	MC		1				KNB073FKVHC
	E22 D70 900	COMPRESSOR	MC			1			KNB092FFAHC
	E22 J14 900	COMPRESSOR	MC				1		KNB092FNDHC
	E22 E05 900	COMPRESSOR	MC					1	SNB130FGBHT
6	E22 065 506	COMPRESSOR RUBBER SET		3	3	3	3		3 RUBBERS/SET
	E22 C34 506	COMPRESSOR RUBBER SET						3	3 RUBBERS/SET
7	E22 D69 661	STOP VALVE (GAS)		1	1	1	1		ø9.52
	E22 T95 661	STOP VALVE (GAS)						1	ø9.52
8	E22 D58 662	STOP VALVE (LIQUID)		1	1	1	1		ø6.35
	E22 T95 662	STOP VALVE (LIQUID)						1	ø6.35
9	E22 927 245	SERVICE PANEL		1	1	1	1	1	
10	E22 J13 233	BACK PANEL			1				
	E22 G12 233	BACK PANEL		1		1	1		
	E22 G15 233	BACK PANEL						1	
11	E22 927 640	EXPANSION VALVE		1	1	1	1		
	E22 A54 640	EXPANSION VALVE						1	
12	E22 927 493	EXPANSION VALVE COIL	LEV	1	1	1	1	1	
13	E22 D65 961	4-WAY VALVE		1	1	1	1	1	
14	E22 B83 523	CONDENSER NET		1	1				
	E22 929 523	CONDENSER NET				1	1	1	
15	E22 D69 293	SEPARATOR		1	1				
	E22 C34 293	SEPARATOR				1	1	1	
16	E22 927 515	MOTOR SUPPORT		1	1				
	E22 929 515	MOTOR SUPPORT				1	1	1	
17	E22 927 297	TOP PANEL		1	1	1	1	1	
18	E22 D69 630	OUTDOOR HEAT EXCHANGER		1					
	E22 J13 630	OUTDOOR HEAT EXCHANGER			1				
	E22 D70 630	OUTDOOR HEAT EXCHANGER				1		1	
	E22 G12 630	OUTDOOR HEAT EXCHANGER					1		
19	E22 D69 301	OUTDOOR FAN MOTOR	MF	1	1	1	1		RC0J50-□□
	E22 C34 301	OUTDOOR FAN MOTOR	MF					1	RC0J50-□□
⑳	E22 927 937	CAPILLARY TUBE		1	1	1	1	1	ø3.0×ø2.0×240
㉑	E22 735 936	CAPILLARY TUBE				2	2	2	ø3.0×ø1.8×600
㉒	E22 838 704	DRAIN SOCKET		1	1	1	1	1	



MUZ-GE25VA MUZ-GE35VA MUZ-GE42VA
1-2. OUTDOOR UNIT ELECTRICAL PARTS

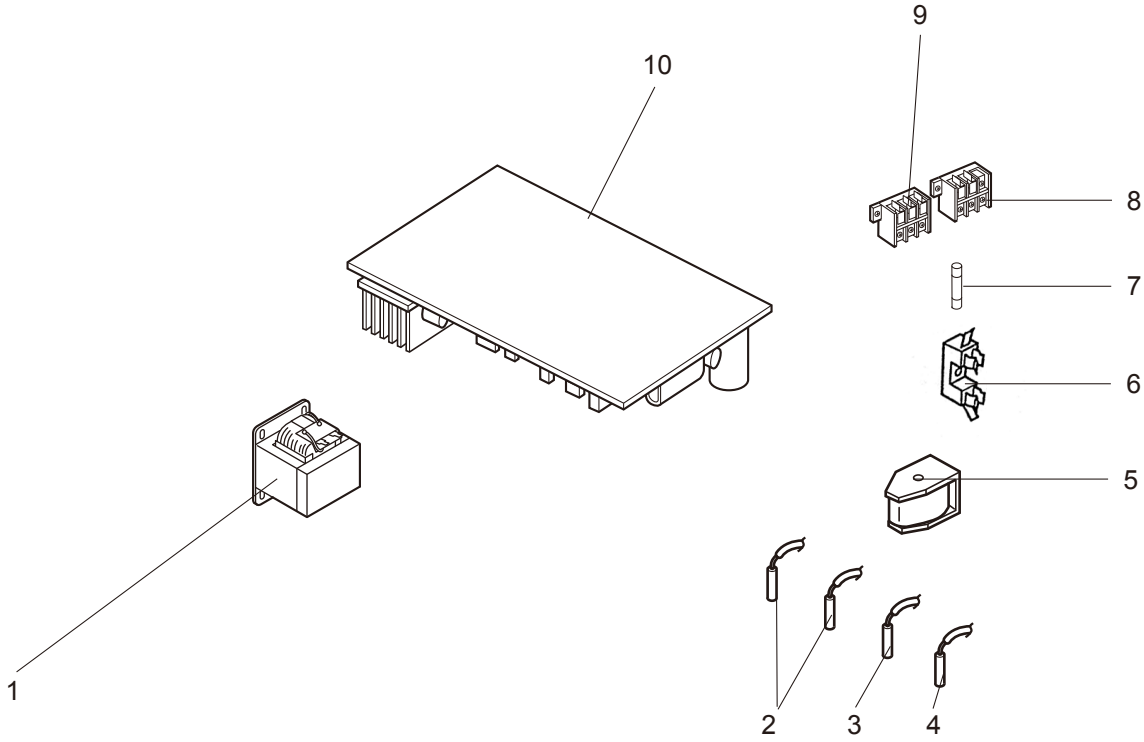

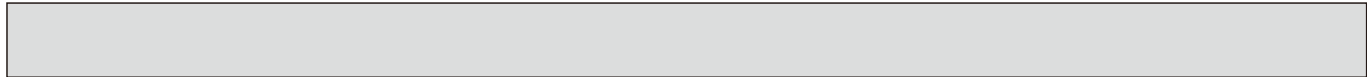

1-2. OUTDOOR UNIT ELECTRICAL PARTS

No.	Part No.	Part Name	Symbol in Wiring Diagram	Q'ty/unit					Remarks
				MUZ-GE25		MUZ-GE35		MUZ-GE42	
				VA-[E1]	VA-[E2]	VA-[E1]	VA-[E2]	VA-[E1]	
1	E22 B72 337	REACTOR	L61	1					
	E22 G10 337	REACTOR	L61		1				
	E22 838 337	REACTOR	L61			1		1	
	E22 G11 337	REACTOR	L61				1		
2	E22 C34 306	THERMISTOR SET	RT61, RT62	1	1	1	1	1	DEFROST, DISCHARGE
3	E22 927 308	AMBIENT TEMPERATURE THERMISTOR	RT65	1	1	1	1	1	
4	E22 C34 307	OUTDOOR HEAT EXCHANGER TEMPERATURE THERMISTOR	RT68	1	1	1	1	1	
5	E22 C34 490	R.V. COIL	21S4	1	1	1	1	1	
6	E22 735 241	FUSE HOLDER		1	1	1	1	1	
7	E22 735 382	FUSE	F61	1	1	1	1	1	T20AL250V
8	E22 D69 374	TERMINAL BLOCK	TB1	1	1	1	1	1	3 P
9	E22 D70 374	TERMINAL BLOCK	TB2	1	1	1	1	1	3 P
10	E22 D69 451	INVERTER P.C. BOARD		1					Includes heat sink and RT64
	E22 J13 451	INVERTER P.C. BOARD			1				
	E22 D70 451	INVERTER P.C. BOARD				1			
	E22 J14 451	INVERTER P.C. BOARD					1		
	E22 E03 451	INVERTER P.C. BOARD						1	

MUZ-GE25VAH MUZ-GE35VAH MUZ-GE42VAH
1-3. OUTDOOR UNIT STRUCTURAL PARTS AND FUNCTIONAL PARTS

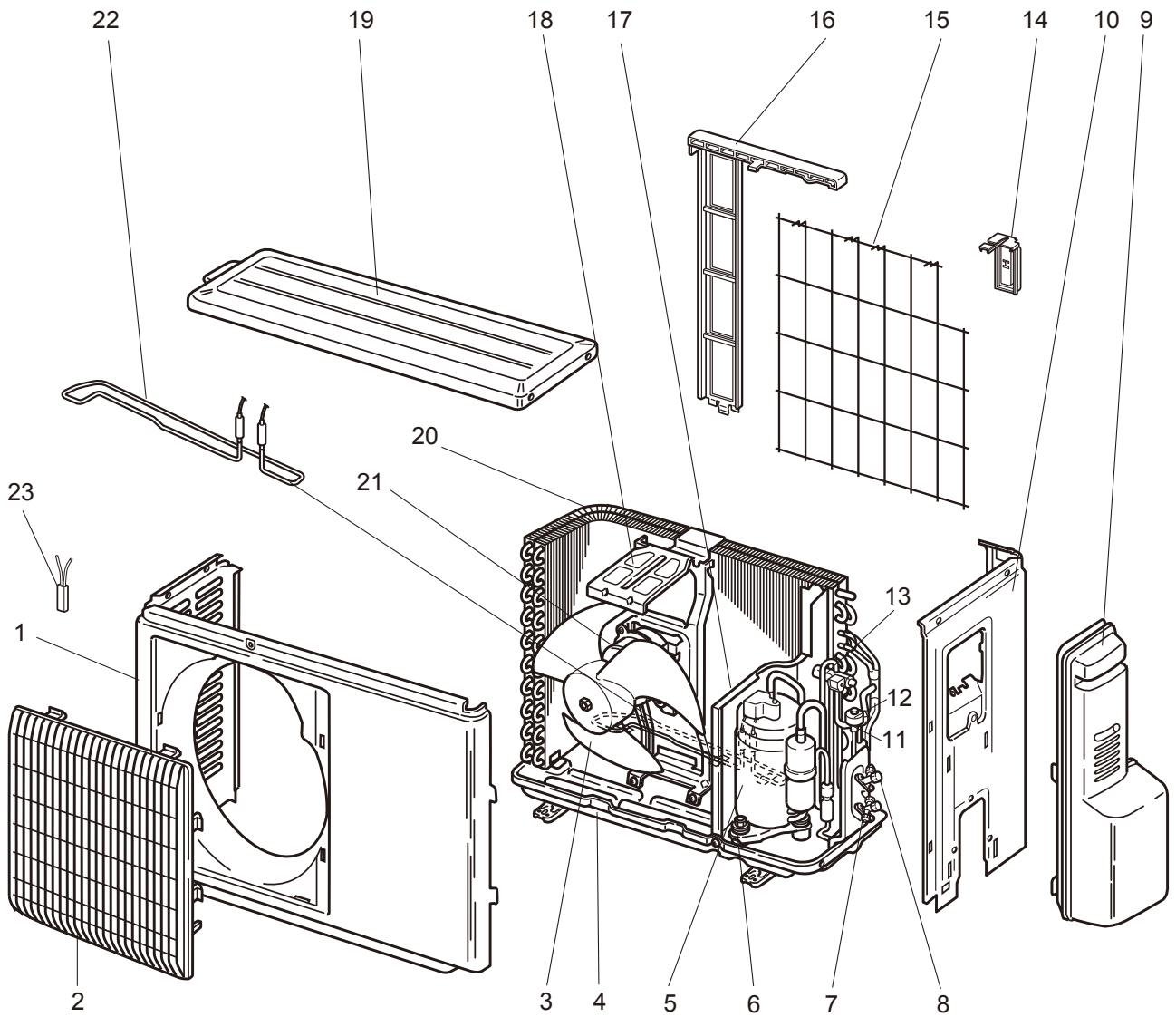

1-3. OUTDOOR UNIT STRUCTURAL PARTS AND FUNCTIONAL PARTS

Part numbers that are circled are not shown in the illustration.

No.	Part No.	Part Name	Symbol in Wiring Diagram	Q'ty/unit				Remarks
				MUZ-GE25	MUZ-GE35		MUZ-GE42	
				VAH-[E1]	VAH-[E1]	VAH-[E2]	VAH-[E1]	
1	E12 927 232	CABINET		1	1	1	1	
2	E12 927 521	GRILLE		1	1	1	1	
3	E12 927 501	PROPELLER FAN		1	1	1	1	
4	E12 D70 290	BASE		1	1	1	1	
5	E12 D69 900	COMPRESSOR	MC	1				KNB073FFDHC
	E12 D70 900	COMPRESSOR	MC		1			KNB092FFAHC
	E12 J14 900	COMPRESSOR	MC			1		KNB092FNDHC
	E12 E05 900	COMPRESSOR	MC				1	SNB130FGBHT
6	E12 065 506	COMPRESSOR RUBBER SET		3	3	3		3 RUBBERS/SET
	E12 C34 506	COMPRESSOR RUBBER SET					3	3 RUBBERS/SET
7	E12 D69 661	STOP VALVE (GAS)		1	1	1		ø9.52
	E12 927 661	STOP VALVE (GAS)					1	ø9.52
8	E12 D58 662	STOP VALVE (LIQUID)		1	1	1		ø6.35
	E12 927 662	STOP VALVE (LIQUID)					1	ø6.35
9	E12 927 245	SERVICE PANEL		1	1	1	1	
10	E12 927 233	BACK PANEL		1	1			
	E12 G14 233	BACK PANEL				1		
	E12 C37 233	BACK PANEL					1	
11	E12 927 640	EXPANSION VALVE		1	1	1		
	E12 838 640	EXPANSION VALVE					1	
12	E12 927 493	EXPANSION VALVE COIL	LEV	1	1	1	1	
13	E12 D65 961	4-WAY VALVE		1	1	1	1	
14	E12 928 079	THERMO HOLDER		1				
	E12 930 079	THERMO HOLDER			1	1	1	
15	E12 928 525	CONDENSER WIRE NET		1				
	E12 930 525	CONDENSER WIRE NET			1	1	1	
16	E12 928 523	CONDENSER NET		1				
	E12 930 523	CONDENSER NET			1	1	1	
17	E12 D77 293	SEPARATOR		1				
	E12 C36 293	SEPARATOR			1	1	1	
18	E12 927 515	MOTOR SUPPORT		1				
	E12 929 515	MOTOR SUPPORT			1	1	1	
19	E12 927 297	TOP PANEL		1	1	1	1	
20	E12 D69 630	OUTDOOR HEAT EXCHANGER		1				
	E12 D70 630	OUTDOOR HEAT EXCHANGER			1		1	
	E12 G12 630	OUTDOOR HEAT EXCHANGER				1		
21	E12 D69 301	OUTDOOR FAN MOTOR	MF	1	1	1		RC0J50-□□
	E12 C34 301	OUTDOOR FAN MOTOR	MF				1	RC0J50-□□
22	E12 C36 526	DEFROST HEATER	H	1	1	1	1	
23	E12 C36 381	HEATER PROTECTOR	26H	1	1	1	1	
②④	E12 927 937	CAPILLARY TUBE		1	1	1	1	ø3.0×ø2.0×240
②⑤	E12 735 936	CAPILLARY TUBE			2	2	2	ø3.0×ø1.8×600



MUZ-GE25VAH MUZ-GE35VAH MUZ-GE42VAH
1-4. OUTDOOR UNIT ELECTRICAL PARTS

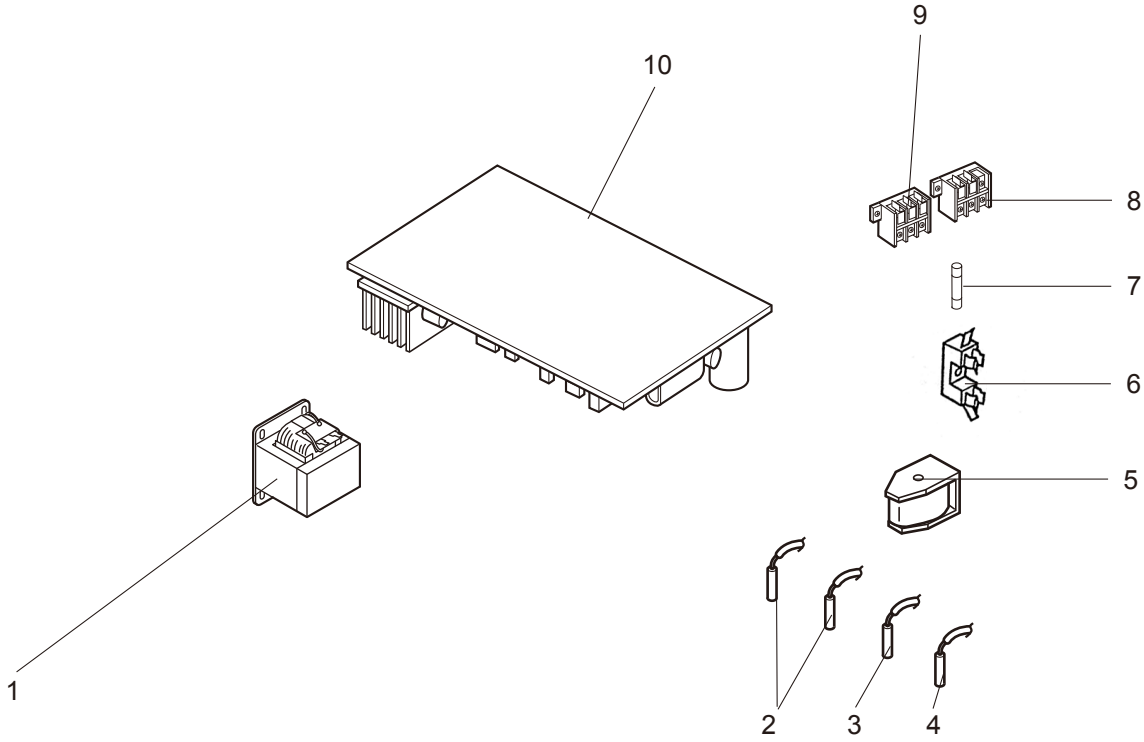



1-4. OUTDOOR UNIT ELECTRICAL PARTS

No.	Part No.	Part Name	Symbol in Wiring Diagram	Q'ty/unit				Remarks
				MUZ-GE25	MUZ-GE35		MUZ-GE42	
				VAH-[E1]	VAH-[E1]	VAH-[E2]	VAH-[E1]	
1	E12 B72 337	REACTOR	L61	1				
	E12 838 337	REACTOR	L61		1		1	
	E12 G11 337	REACTOR	L61			1		
2	E12 C34 306	THERMISTOR SET	RT61, RT62	1	1	1	1	DEFROST, DISCHARGE
3	E12 927 308	AMBIENT TEMPERA- TURE THERMISTOR	RT65	1	1	1	1	
4	E12 C34 307	OUTDOOR HEAT EX- CHANGER TEMPERA- TURE THERMISTOR	RT68	1	1	1	1	
5	E12 C34 490	R.V. COIL	21S4	1	1	1	1	
6	E12 735 241	FUSE HOLDER		1	1	1	1	
7	E12 735 382	FUSE	F61	1	1	1	1	T20AL250V
8	E12 D69 374	TERMINAL BLOCK	TB1	1	1	1	1	3 P
9	E12 D70 374	TERMINAL BLOCK	TB2	1	1	1	1	3 P
10	E12 D77 451	INVERTER P.C. BOARD		1				Includes heat sink and RT64
	E12 D78 451	INVERTER P.C. BOARD			1			
	E12 J16 451	INVERTER P.C. BOARD				1		
	E12 E04 451	INVERTER P.C. BOARD					1	

MUZ-GE50VA

1-5. OUTDOOR UNIT STRUCTURAL PARTS, ELECTRICAL PARTS AND FUNCTIONAL PARTS

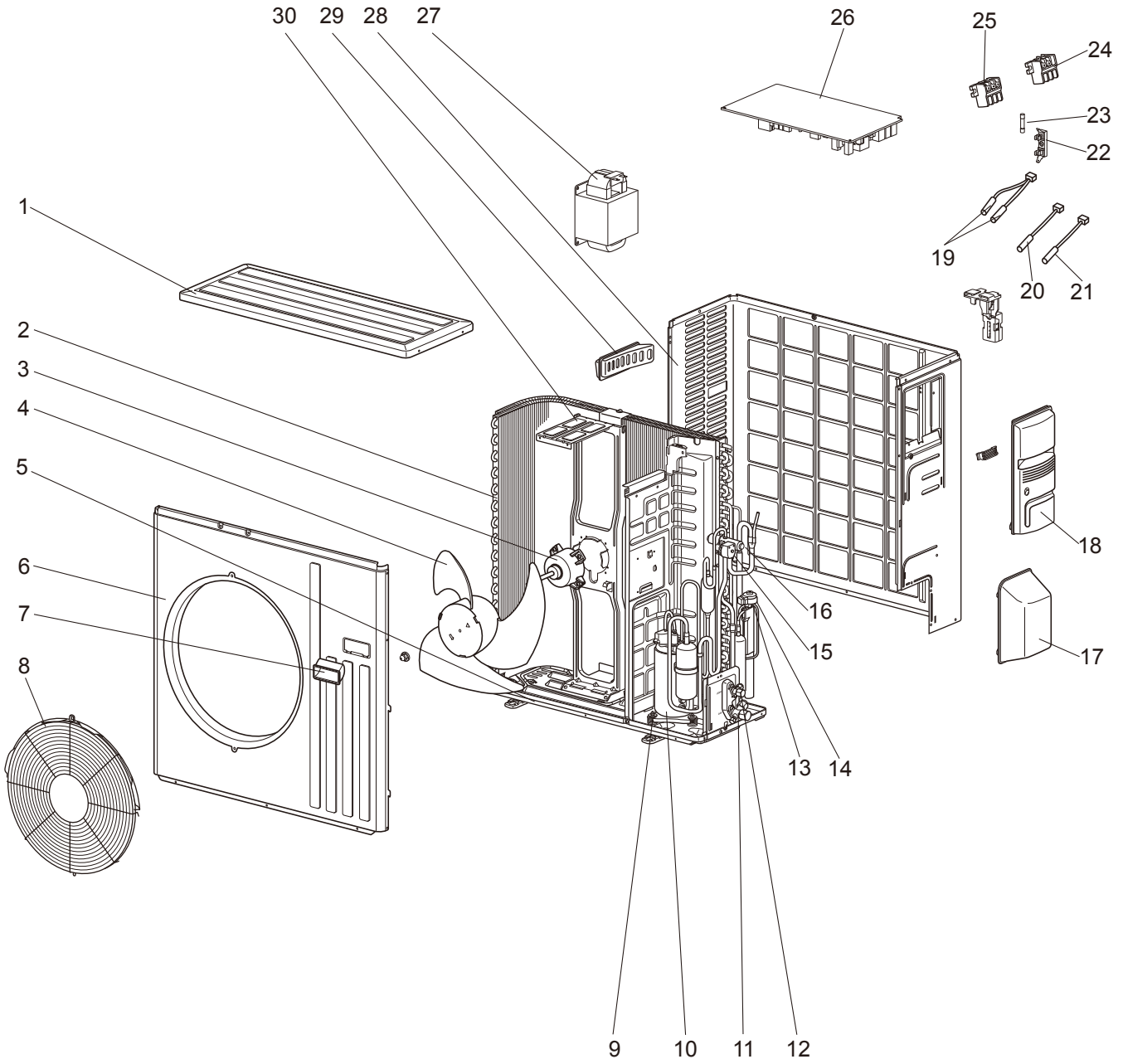

1-5. OUTDOOR UNIT STRUCTURAL PARTS, ELECTRICAL PARTS AND FUNCTIONAL PARTS

Part numbers that are circled are not shown in the illustration.

No.	Part No.	Part Name	Symbol in Wiring Diagram	Q'ty/unit		Remarks
				MUZ-GE	50VA- E1	
1	E22 819 297	TOP PANEL		1		
2	E22 D84 630	OUTDOOR HEAT EXCHANGER		1		
3	E22 938 301	OUTDOOR FAN MOTOR	MF	1		RC0J60-□□
4	E22 851 501	PROPELLER FAN		1		
5	E22 D86 290	BASE		1		
6	E22 819 232	CABINET		1		
7	E22 819 009	HANDLE		1		
8	E22 D84 521	FAN GUARD		1		Includes ice guard
9	E22 C34 506	COMPRESSOR RUBBER SET		3		3 RUBBERS/SET
10	E22 E05 900	COMPRESSOR	MC	1		SNB130FGBHT
11	E22 D58 661	STOP VALVE (GAS)		1		∅12.7
12	E22 D58 662	STOP VALVE (LIQUID)		1		∅6.35
13	E22 851 640	EXPANSION VALVE		1		
14	E22 E05 493	EXPANSION VALVE COIL	LEV	1		
15	E22 D58 490	R.V. COIL	21S4	1		
16	E22 C18 961	4-WAY VALVE		1		
17	E22 819 650	VALVE COVER		1		
18	E22 819 245	SERVICE PANEL		1		
19	E22 E05 308	THERMISTOR SET	RT61, RT62	1		DEFROST, DISCHARGE
20	E22 D58 309	AMBIENT TEMPERATURE THERMISTOR	RT65	1		
21	E22 E05 307	OUTDOOR HEAT EXCHANGER TEMPERATURE THERMISTOR	RT68	1		
22	E22 735 241	FUSE HOLDER		1		
23	E22 735 382	FUSE	F61	1		T20AL250V
24	E22 D69 374	TERMINAL BLOCK	TB1	1		3 P
25	E22 D70 374	TERMINAL BLOCK	TB2	1		3 P
26	E22 E05 451	INVERTER P.C. BOARD		1		Includes heat sink and RT64
27	E22 D58 337	REACTOR	L61	1		
28	E22 E09 233	BACK PANEL (OUT)		1		
29	E22 817 009	HANDLE		1		
30	E22 851 515	MOTOR SUPPORT		1		
③①	E22 853 936	CAPILLARY TUBE (TAPER PIPE)		1		∅3.6 × ∅2.4 × 50
③②	E22 817 704	DRAIN SOCKET		1		
③③	E22 444 705	DRAIN CAP		2		2PCS/SET

MUZ-GE50VAH

1-6. OUTDOOR UNIT STRUCTURAL PARTS, ELECTRICAL PARTS AND FUNCTIONAL PARTS

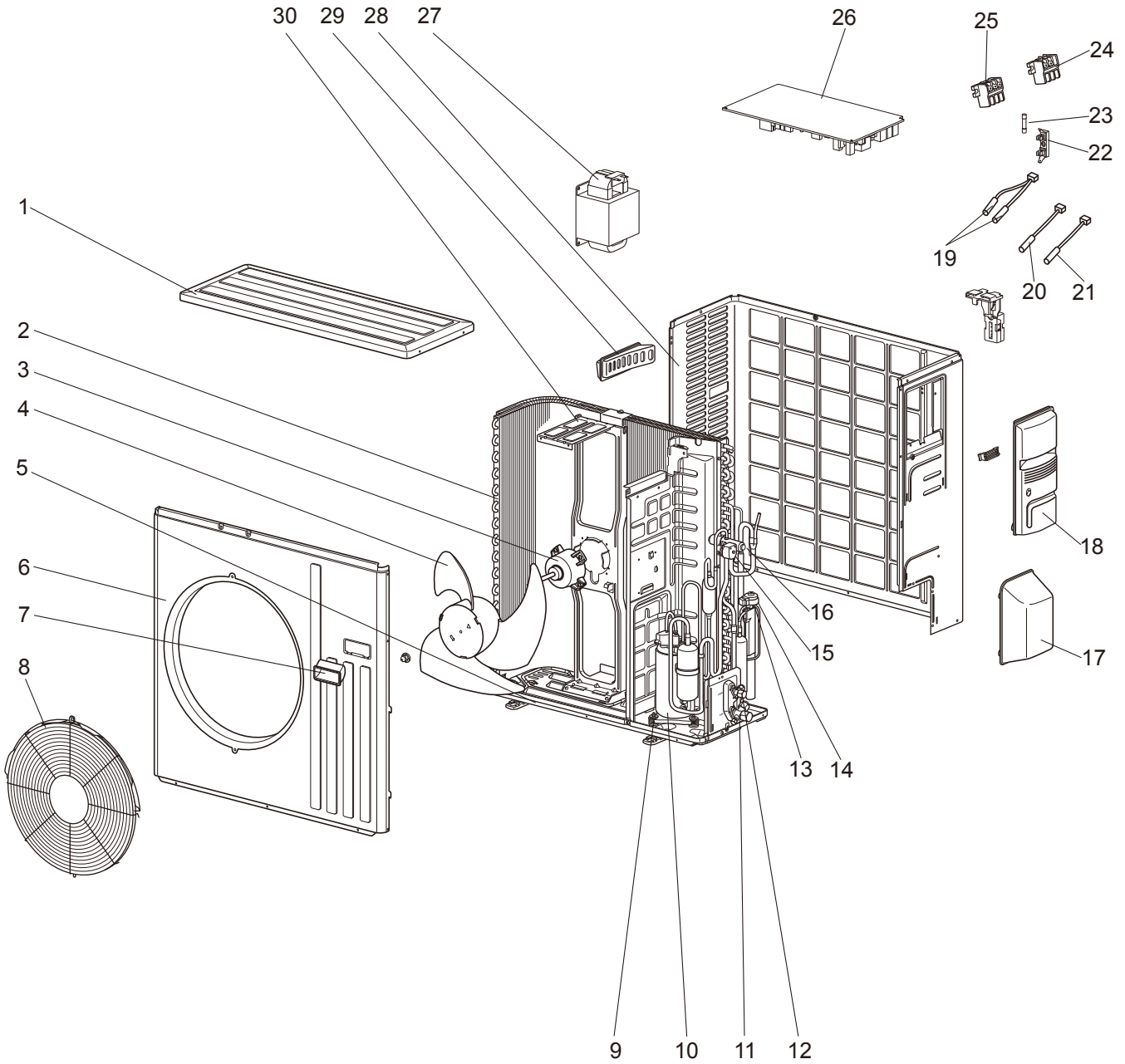

1-6. OUTDOOR UNIT STRUCTURAL PARTS, ELECTRICAL PARTS AND FUNCTIONAL PARTS

Part numbers that are circled are not shown in the illustration.

No.	Part No.	Part Name	Symbol in Wiring Diagram	Q'ty/unit		Remarks
				MUZ-GE		
				50VAH- [E1]		
1	E12 819 297	TOP PANEL			1	
2	E12 D84 630	OUTDOOR HEAT EXCHANGER			1	
3	E12 938 301	OUTDOOR FAN MOTOR	MF		1	RC0J60-□□
4	E12 851 501	PROPELLER FAN			1	
5	E12 D84 290	BASE			1	
6	E12 819 232	CABINET			1	
7	E12 819 009	HANDLE			1	
8	E12 D84 521	FAN GUARD			1	Includes ice guard
9	E12 C34 506	COMPRESSOR RUBBER SET			3	3 RUBBERS/SET
10	E12 E05 900	COMPRESSOR	MC		1	SNB130FGBHT
11	E12 D58 661	STOP VALVE (GAS)			1	ø12.7
12	E12 D58 662	STOP VALVE (LIQUID)			1	ø6.35
13	E12 851 640	EXPANSION VALVE			1	
14	E12 E05 493	EXPANSION VALVE COIL	LEV		1	
15	E12 D58 490	R.V. COIL	21S4		1	
16	E12 C18 961	4-WAY VALVE			1	
17	E12 819 650	VALVE COVER			1	
18	E12 819 245	SERVICE PANEL			1	
19	E12 E05 308	THERMISTOR SET	RT61, RT62		1	DEFROST, DISCHARGE
20	E12 D58 309	AMBIENT TEMPERATURE THERMISTOR	RT65		1	
21	E12 E05 307	OUTDOOR HEAT EXCHANGER TEMPERATURE THERMISTOR	RT68		1	
22	E12 735 241	FUSE HOLDER			1	
23	E12 735 382	FUSE	F61		1	T20AL250V
24	E12 D69 374	TERMINAL BLOCK	TB1		1	3 P
25	E12 D70 374	TERMINAL BLOCK	TB2		1	3 P
26	E12 E06 451	INVERTER P.C. BOARD			1	Includes heat sink and RT64
27	E12 D58 337	REACTOR	L61		1	
28	E12 E06 233	BACK PANEL (OUT)			1	
29	E12 817 009	HANDLE			1	
30	E12 851 515	MOTOR SUPPORT			1	
③①	E12 853 936	CAPILLARY TUBE (TAPER PIPE)			1	ø3.6 × ø2.4 × 50
③②	E12 E05 381	HEATER PROTECTOR	26H		1	
③③	E12 E05 526	DEFROST HEATER	H		1	

MUZ-GE60VA MUZ-GE71VA

1-7. OUTDOOR UNIT STRUCTURAL PARTS, ELECTRICAL PARTS AND FUNCTIONAL PARTS

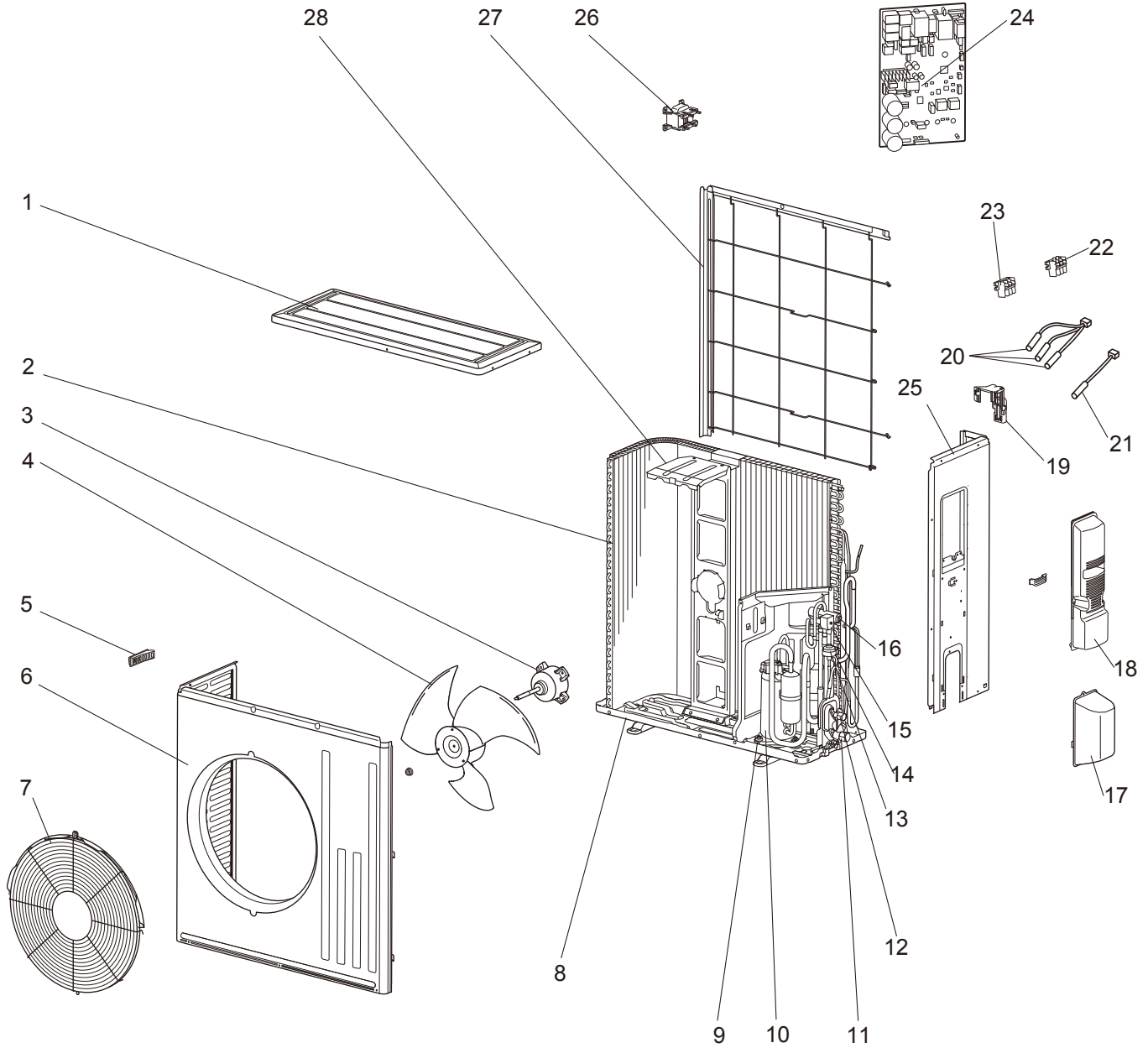

1-7. OUTDOOR UNIT STRUCTURAL PARTS, ELECTRICAL PARTS AND FUNCTIONAL PARTS

Part numbers that are circled are not shown in the illustration.

No.	Part No.	Part Name	Symbol in Wiring Diagram	Q'ty/unit		Remarks
				MUZ-GE		
				60VA- [E1]	71VA- [E1]	
1	E22 F28 297	TOP PANEL		1	1	
2	E27 805 630	OUTDOOR HEAT EXCHANGER		1		
	E27 806 630	OUTDOOR HEAT EXCHANGER			1	
3	E22 F28 301	OUTDOOR FAN MOTOR	MF	1	1	RC0J60-□□
4	E22 F28 501	PROPELLER FAN		1	1	
5	E22 817 009	HANDLE		1	1	
6	E22 F28 232	CABINET		1	1	
7	E22 F73 521	FAN GUARD		1	1	Includes ice guard
8	E22 F28 290	BASE		1	1	
9	E22 C34 506	COMPRESSOR RUBBER SET		3	3	3 RUBBERS/SET
10	E22 F28 900	COMPRESSOR	MC	1		SNB130FGBMT
	E22 J40 900	COMPRESSOR	MC		1	SNB172FEKMT
11	E22 F28 661	STOP VALVE (GAS)		1	1	ø15.88
12	E22 F28 662	STOP VALVE (LIQUID)		1		ø6.35
	E22 F29 662	STOP VALVE (LIQUID)			1	ø9.52
13	E22 851 640	EXPANSION VALVE		1		
	E22 853 640	EXPANSION VALVE			1	
14	E22 F28 493	EXPANSION VALVE COIL	LEV	1	1	
15	E22 F28 490	R.V. COIL	21S4	1	1	
16	E22 C18 961	4-WAY VALVE		1	1	
17	E22 F28 650	VALVE COVER		1	1	
18	E22 F28 245	SERVICE PANEL		1	1	
19	E22 F28 079	THERMO HOLDER		1	1	
20	E22 F28 308	THERMISTOR SET	RT61, RT62, RT68	1	1	DEFROST, DISCHARGE, OUTDOOR HEAT EXCHANGER TEMPERATURE
21	E22 F28 309	AMBIENT TEMPERATURE THERMISTOR	RT65	1	1	
22	E22 F29 374	TERMINAL BLOCK	TB1	1	1	3 P
23	E22 F28 374	TERMINAL BLOCK	TB2	1	1	3 P
24	E22 K11 451	INVERTER P.C. BOARD		1		Includes heat sink and RT64
	E22 K12 451	INVERTER P.C. BOARD			1	
25	E22 F28 233	BACK PANEL (OUT)		1	1	
26	E22 F28 337	REACTOR	L	1	1	
27	E22 L87 523	CONDENSER NET		1	1	
28	E22 F28 515	MOTOR SUPPORT		1	1	
⑲	E22 527 936	CAPILLARY TUBE		1	1	ø4.0 × ø2.4 × 100
⑳	E22 F28 704	DRAIN SOCKET		1	1	

MITSUBISHI ELECTRIC CORPORATION

HEAD OFFICE: TOKYO BUILDING, 2-7-3, MARUNOUCHI, CHIYODA-KU, TOKYO 100-8310, JAPAN

© Copyright 2008 MITSUBISHI ELECTRIC CORPORATION

Issued: Mar. 2020. No. OBB516 REVISED EDITION-G

Issued: Jul. 2013. No. OBB516 REVISED EDITION-F

Issued: Apr. 2012. No. OBB516 REVISED EDITION-E

Issued: Jun. 2010. No. OBB516 REVISED EDITION-D 5

Issued: Jan. 2010. No. OBB516 REVISED EDITION-C 5

Issued: Oct. 2009. No. OBB516 REVISED EDITION-B 5

Issued: Dec. 2008. No. OBB516 REVISED EDITION-A 5

Published: Aug. 2008. No. OBB516 6

Made in Japan

Specifications are subject to change without notice.