

Inverter Driven Heat Pump

18,000 BTU Single Zone Mid Static Duct System

Job Name _____
 Location _____
 Engineer _____
 Submitted To _____
 Submitted By _____
 Reference _____

Date _____
 Approval _____
 Construction _____
 Unit No _____
 Drawing No _____

PRODUCT FEATURES

- Up To 0.8" WC
- Quiet Operation (as low as 24 db)
- Automatic Static Pressure Detection
- Heating Operation Rated Down to -5 °F
- Built-in Drain Pump
- Lineset Length up to 98ft
- Controls Sold Separately



MODEL NUMBERS			
Indoor Unit	ARUH18LUAS		
Outdoor Unit	AOUH18LUAS1		
System	18LUAS1R		
EFFICIENCIES			
SEER	--		
SEER 2	18.6		
EER	--		
EER 2	11.7		
HSPF	--		
HSPF 2 (IV) / HSPF 2 (V)	10/8.4		
COP	kW/kW	--	
COP	Btu/hW	--	
COP2	kW/kW	3.3	
COP2	Btu/hW	11.3	
OUTDOOR TEMPERATURE OPERATION RANGE			
Cooling	°F(°C)		14 to 115 (-10 to 46)
Heating			-5 to 75 (-21 to 24)
CAPACITIES			
Cooling	Rated	Btu/h	17100
	Min.–Max.		3,100–20,100
Heating	Rated		21600
	Min.–Max.		3,100–25,600
LINESET REQUIREMENTS			
Connection Method	Flare		
Liquid	in (mm)	Ø1/4 (Ø6.35)	
Gas		Ø1/2 (Ø12.70)	
Pre-charge length	ft (m)	66 (20)	
Minimum Length		16 (5)	
Max. length		98 (30)	
Max. height difference		49 (15)	
INDOOR DIMENSIONS & WEIGHT			
Net (H x W x D)	in (mm)	11-13/16 x 39-3/8 x 27-9/16 (300 x 1,000 x 700)	
Gross (H x W x D)		15-3/4 x 48-3/4 x 34-7/16 (400 x 1,238 x 875)	
Net Weight	lb (kg)	90 (41)	
Gross Weight		108 (49)	
OUTDOOR DIMENSIONS & WEIGHT			
Net (H x W x D)	in (mm)	24-7/8 x 31-7/16 x 11-7/16 (632 x 799 x 290)	
Gross (H x W x D)		27-1/4 x 37 x 14-3/4 (692 x 940 x 375)	
Net Weight	lb (kg)	86 (39)	
Gross Weight		95 (43)	

Warranty Information



7 Year Compressor, 5 Year Parts out-of-the-box Warranty

10 Year Compressor, 10 Year Parts Warranty when registered within 60 days of installation in a residence

12 Year Compressor, 12 Year Parts Warranty when registered within 60 days of installation in a residence, and installed by a Fujitsu Elite contractor

ACCESSORIES

UTY-RNRUZ- Series	Wired Remote Controller
UTY-RSRY	Simple Remote Controller
UTY-RHRY	Simple Remote Controller
UTY-LBTUM	IR Receiver Kit with Wireless Remote Controller
UTY-XSZXZ1	Remote Sensor Unit
UTD-LFNB	Long-life Filter
UTY-XWZXZG	External Connect Kit
UTY-XCSX	External Input and Output PCB
UTZ-GXNA	External Input and Output PCB Bracket
UTY-TFSXJ4	WLAN Adapter
UTY-VMSX	Modbus Converter
UTY-VKSX	KNX Converter
UTY-TTRXZ1	Thermostat Converter
UTY-VTGX	Network Converter
UTY-VTGXV	Network Converter (AC power supply)
UTY-TERX	External Switch Controller

Due to continuous product improvements, specifications are subject to change without notice. Please log in to the Fujitsu Portal for the most up-to-date documentation <https://connect.fujitsugeneral.com>

Effective Date: 4/12/2023

Inverter Driven Heat Pump

18,000 BTU Single Zone Mid Static Duct System

FAN DATA				
Indoor Unit Airflow rate	Cooling	HIGH	CFM (m3/h)	618 (1,050)
		MED		494 (840)
		LOW		430 (730)
		QUIET		371 (630)
	Heating	HIGH		618 (1,050)
		MED		494 (840)
		LOW		430 (730)
		QUIET		371 (630)
Outdoor Unit Airflow rate	Cooling			1,395 (2,370)
	Heating			1,460 (2,480)
SOUND PRESSURE				
Indoor Unit	Cooling	HIGH	dB (A)	31
		MED		28
		LOW		25
		QUIET		24
	Heating	HIGH		31
		MED		28
		LOW		25
		QUIET		24
Outdoor Unit	Cooling			52
	Heating			55
REFRIGERANT				
Type				R410A
Charge	lb oz	2 lb 12 oz		
	g	1250		
Oil Type				POE (RB68)

ELECTRICAL SPECIFICATIONS				
Voltage/Frequency/Phase		208/230 V~ 60 Hz		
Available Voltage Range		187-253 V		
Current	Cooling	Rated	A	6.5
	Heating	Rated		8.5
Maximum Operating Current		Cooling		11.8
		Heating		14.8
Starting current		8.1		
MCA		18.1		
Maximum Circuit Breaker		20		
Input Power	Cooling	Rated	kW	1.46
		Min.-Max.		0.17-2.14
	Heating	Rated		1.91
		Max.	2.44	
Power Factor	Cooling	%		
	Heating	97.7		
		98.3		
OTHER				
Moisture Removal		pints/h (L/h)	3.4 (1.6)	
Energy Star		Yes		
Drain hose	Material	PVC		
	Tip diameter	in (mm)	Ø1/2 (Ø13.0) (I.D.) Ø5/8 to Ø11/16 (Ø16.0 to Ø16.7)	
Operation Range	Cooling	°F (°C)	64 to 90 (18 to 32)	
	Heating	%RH	80 or less	
Static Pressure Range		inWG (Pa)	0.12 to 0.80 (30 to 200)	

DIMENSIONS:

Indoor Unit

Units: In. (mm)

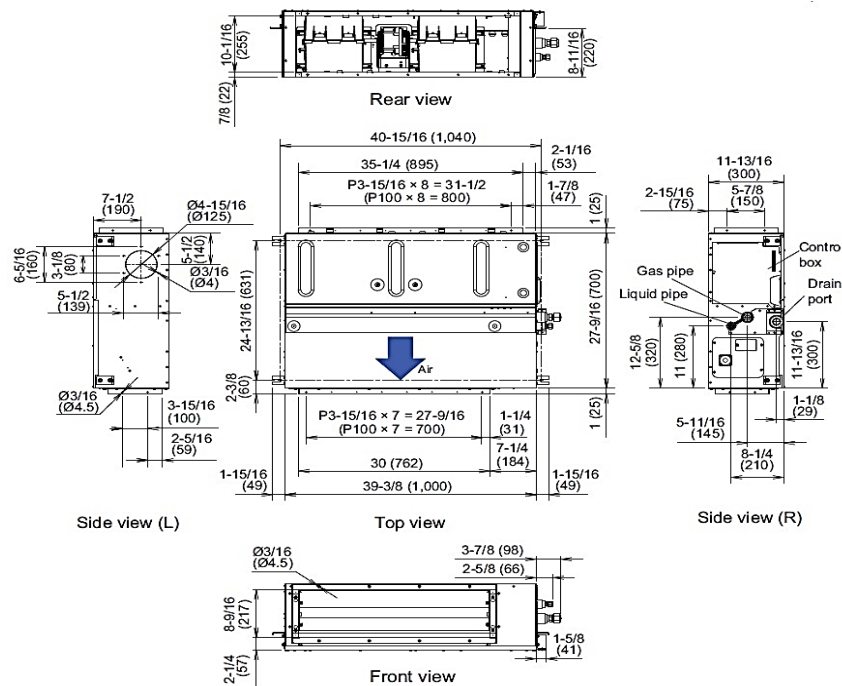

DIMENSIONS

Units: In. (mm)

Outdoor Unit

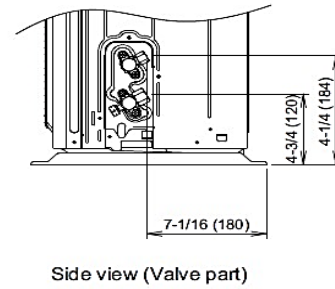
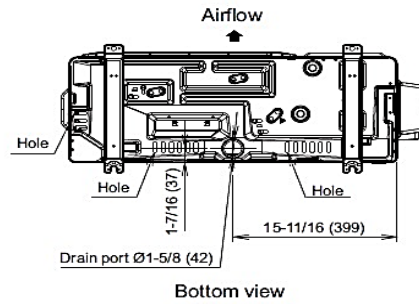
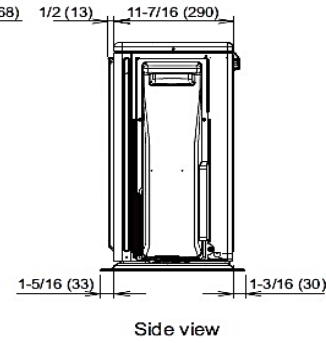
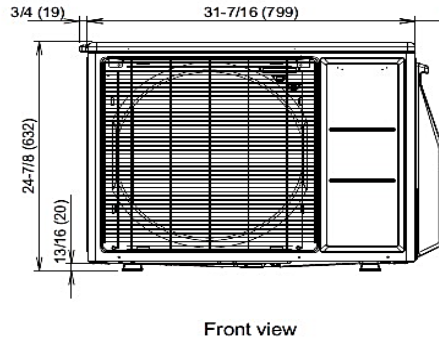
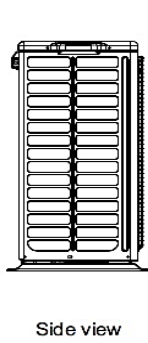
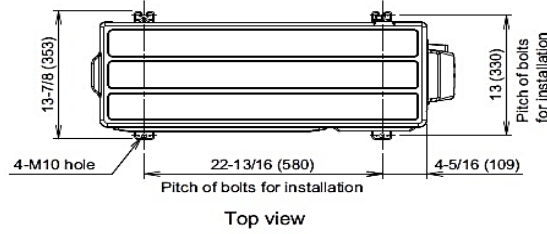

The Fujitsu logo is a worldwide trademark of Fujitsu General Limited. The Airstage logo and name is a worldwide trademark of Fujitsu General Limited and is a registered trademark in Japan, the USA and other countries or areas. Copyright 2022 Fujitsu General America, Inc. Fujitsu's products are subject to continuous improvements. Fujitsu reserves the right to modify product design, specifications and information in this brochure without notice and without incurring any obligations.

Note: Specifications are based on the following conditions:
 Cooling: Indoor temperature of 80°F (26.7°C) DB/67°F (19.4°C) WB, and outdoor temperature of 95°F (35°C) DB/75°F (23.9°C) WB. Heating: Indoor temperature of 70°F (21.1°C) DB/60°F (15.6°C) WB, and outdoor temperature of 47°F (8.3°C) DB/43°F (6.1°C) WB. Pipe length: 25ft. (7.5m), Height difference: 0ft. (0m) (Outdoor unit - indoor unit).