

VRF Outdoor Unit 38VMA192RDS6-1 - Heat Recovery



Submittal Data

Job Data _____ Location _____
 Buyer _____ Buyer PO # _____ Carrier # _____
 Unit Number _____ Model Number _____
 Performance Data Certified By _____ Date _____



Heat Recovery Features

- Modules available from 6 to 28 tons
- Modules have inverter-driven scroll compressors
- Direct-drive, inverter-driven outdoor motor
- Up to 3280 ft (1000 m) actual total system piping (liquid line)
- 656 ft (200 m) actual piping length from outdoor unit to furthest fan coil
- Up to 3937 ft (1200 m) control wiring between the outdoor units and indoor units
- Operating temperature range
Cooling (db): 5° to 125°F (-15° to 52°C)
Heating (wb): -13° to 64°F (-25° to 18°C)
- Protection: high pressure sensor and switch, low pressure sensor and switch, process controller board fuse, inverter overload protection
- 7-year compressor limited warranty
- 5-year parts limited warranty

Header Model		38VMA192RDS6-1
PERFORMANCE		
Nominal Cooling Capacity	Btu/h	191,100
Nominal Heating Capacity	Btu/h	215,000
Maximum Total Connected Indoor Unit Capacity		50% to 150%
SIMULTANEOUS COOLING AND HEATING EFFICIENCY†		
SCHE, Ducted FCUs		25.50
SCHE, Ductless FCUs		28.20
COOLING EFFICIENCY†		
EER/IEER, Ducted FCUs	Btu/Wh	11.10/23.60
Power Consumption, Ducted FCUs	kW	15.90
EER/IEER, Ductless FCUs	Btu/Wh	11.30/23.90
Power Consumption, Ductless FCUs	kW	14.70
HEATING EFFICIENCY†		
COP at 47°F, Ducted FCUs		3.33
Power Consumption, Ducted FCUs	kW	17.40
COP at 47°F, Ductless FCUs		3.38
Power Consumption, Ductless FCUs	kW	16.20
Fan Type (Qty)		Propeller (2)
Airflow, Standard Range	CFM	11,300
Sound Pressure	dBA	64.9
External Static Pressure*	in. wg	0.24

LEGEND

db	— Dry Bulb
COP	— Coefficient of Performance
EER	— Energy Efficiency Ratio
FCU	— Fan Coil Unit
IEER	— Integrated Energy Efficiency Ratio
wb	— Wet Bulb
SCHE	— Simultaneous Cooling and Heating Efficiency

ELECTRICAL		
Power Supply	V/Ph/Hz	460/3/60
Minimum Circuit Amps (MCA)		35
Recommended Fuse Size		40
COMPRESSORS		
Type (Number)		Inverter Hermetic Scroll (2)
FAN MOTOR		
Motor Type (Steps)		Inverter Direct Driven (13)
Motor Output	kW	2 X 0.34
PHYSICAL DATA		
Pipe Connection Size - Liquid (High Pressure)	in.	7/8 (Brazed)
Pipe Connection Size - Gas (Low Pressure)	in.	1-1/8 (Brazed)
Refrigerant		R-410A
Factory Charge††	lb	44.2
Unit Width	in.	78-3/8
Unit Height	in.	64-3/8
Unit Depth	in.	31-1/8
Net Weight	lb	1137

†Rated per AHRI (Air-Conditioning, Heating and Refrigeration Institute) 1230 Standard.

Cooling: Indoor 80°F (27°C) db/67°F (20°C) wb; Outdoor 95°F (35°C) db
 Heating: Indoor 70°F (21°C) db; Outdoor 47°F (8°C) db/43°F (6°C) wb

*Requires setting by menu functions.

††Additional charge required.

NOTE: Unit cabinet and coil slab shall be capable of withstanding 500-hour salt spray test.

Manufacturer reserves the right to discontinue, or change at any time, specifications or designs without notice and without incurring obligations.

DIMENSIONAL DRAWING OUTDOOR UNIT 38VMA192RDS6-1

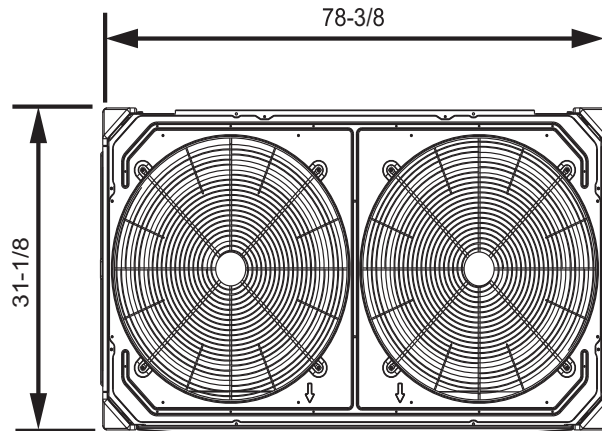
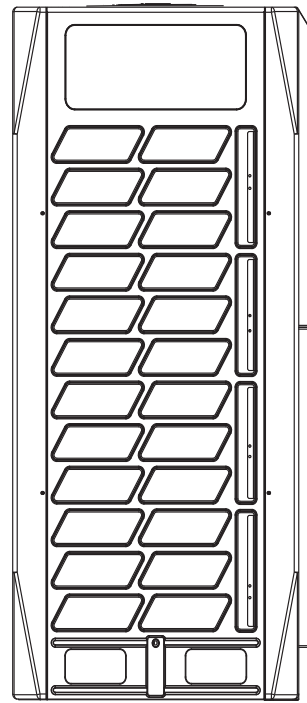
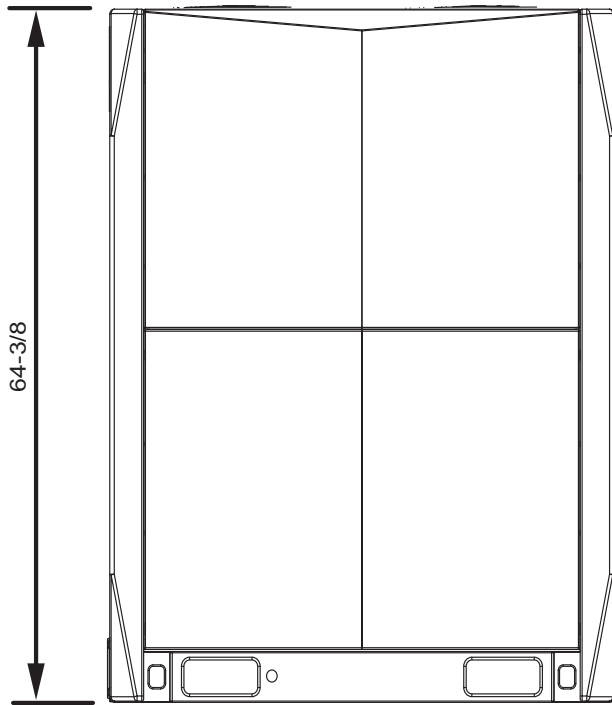

NOTE: All dimensions shown in inches.

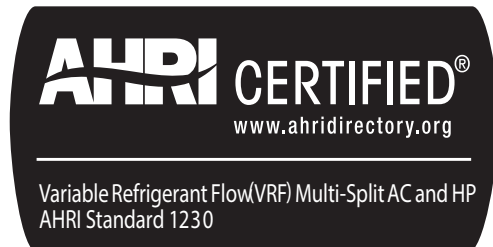

© Carrier Corporation 2018

Manufacturer reserves the right to discontinue, or change at any time, specifications or designs without notice and without incurring obligations.

Printed in U.S.A.

Form 38VMR1926-C-3SD

Pg 2

08-18

Replaces: 38VMR1926-C-2SD