

see what Delta can doSM

GENERATOR PAN AND AUTO DRAIN

GENERATOR PAN STANDARD SPECIFICATIONS:

- High-temp impact-resistant resin
- Weight capacity: 250lbs.
- Package includes: Pan with 3/4" MGHT male threaded NPT and 1/2" NPT Female brass connection
- For use with 5GE-SMP and 5P-EST Series Generators

AUTO DRAIN STANDARD SPECIFICATIONS:

- Connects to a factory installed auto drain PCB terminal block, located inside the generator cabinet
- Inlet & Outlet - 1/2" NPT brass female thread
- For use with 5GE-SMP and 5P-EST Series Generators
- Normally Closed (N.C.) Valve

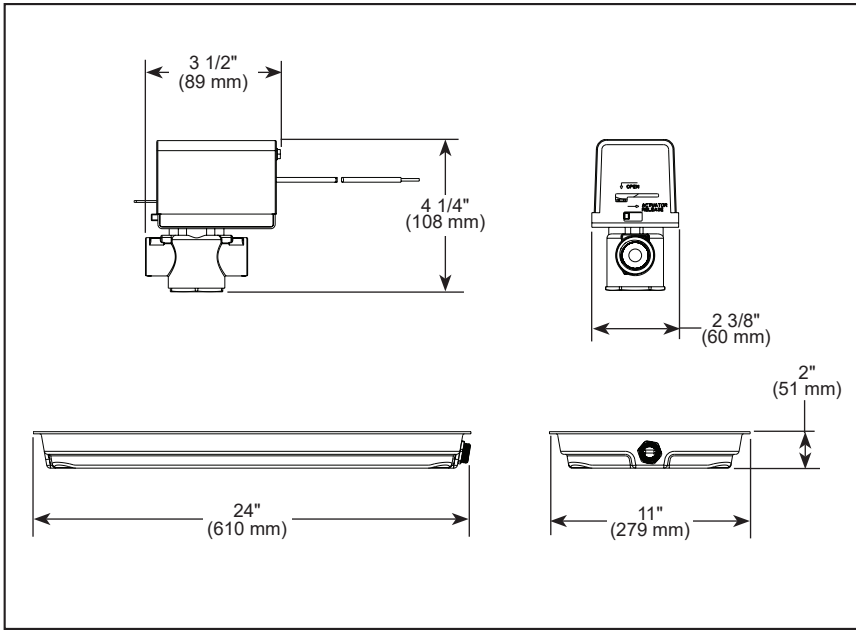

WARRANTY

- Steam Generators – Lifetime limited warranty; or for commercial purchasers (including for steam bath generators with model numbers beginning with 5COM, which are intended solely for heavy commercial use), one (1) year from the date the product is received by the original purchaser or their authorized representative (installation contractor, etc.).
- Electronic Parts for Steam Bath Generators, Controls, Spa Options and Accessories – two (2) years from the date the product is received by the original consumer purchaser or their authorized representative (installation contractor, etc.); or for commercial purchasers, one (1) year from the date the product is received by the original purchaser or their authorized representative (installation contractor, etc.).
- Please go to www.deltafaucet.com for the complete details of our limited warranty.