



Laing Thermotech Series
autocirc[®]

INSTANT HOT WATER SYSTEM
As little as 14 Watts!

Get instant hot water at every faucet with as little as 14 watts!

How autocirc® Works

The autocirc is the most efficient system, turning on only when the system needs to be replenished with hot water. The pump is installed under the sink farthest from the water heater where hot water takes the longest to arrive. No recirculation line is required.

Fixed Thermostat Models

- A built-in temperature sensor automatically turns the pump ON when water temperature in the hot water line cools down to 85°F. Water is then pumped from the hot to cold line. The autocirc pump turns OFF automatically when water temperature reaches 95°F, ensuring instant availability of shower warm water with maximum temperature hot water only seconds behind. When the pump is OFF, a built-in auto closure device prevents any other hot-to-cold line or cold-to-hot line mix.

Adjustable Thermostat Models

- For models with the adjustable thermostat, there is an adjustable "ON" temperature range from 77°F to 91°F (25°C to 33°C). This built-in temperature sensor will turn the circulator OFF when it reaches 95°F (35°C) and turn the circulator ON when the temperature cools down to the "ON" temperature set point.

Hot water will also be instantly available at all other faucets located on the hot water supply line between the water heater and the faucet where the autocirc is installed.

Design

The autocirc has a spherical motor. The only moving part of the pump is a spherical rotor/impeller unit which is suspended on a wear resistant ceramic ball. Laing pumps are completely shaft-less. The patented Laing design eliminates problem shafts, seals and cylindrical bearings found on conventional, mechanically sealed canned pumps.



- No return line required!
- Installs within minutes, directly under the sink.

Saves the average family of four thousands of gallons of water annually.

Benefits

- Long lasting, silent operation
- Requires only one pump and one installation for all fixtures on the hot water plumbing line
- Does not require a return line
- Saves thousands of gallons of water
- Resistant to scale build up
- Maintenance free without blockage
- Saves money and pays for itself in a short period of time

Features

- Built-in 24-hour timer which allows the selection of system operating periods to suit family usage
- Built-in fixed thermostat or an optional, adjustable ON thermostat
- Highly efficient ECM technology
- No shaft, no seal
- Single bearing design
- Comes complete with a 6 ft. long power cord

Technical Data

Motor Design: Shaft-less spherical motor

Input: 14 Watts

Maximum Fluid Temperature: 203°F / 95°C

Maximum Line Pressure: 145 PSI

Compatible Fluids: Potable water



Available Models

Part Number	Description	Model	Weight
60A0G6001	Lead Free Brass* autocirc® 1/2" Fixed Thermostat with Timer	E1-BCAFNCTW-01	4lbs.
60A0G6002	Lead Free Brass* autocirc® 1/2" Adjustable "ON" Thermostat with Timer	E1-BCAFNRTW-01	4lbs.

*Less than 0.25% Pb by weight on wetted parts surface areas.

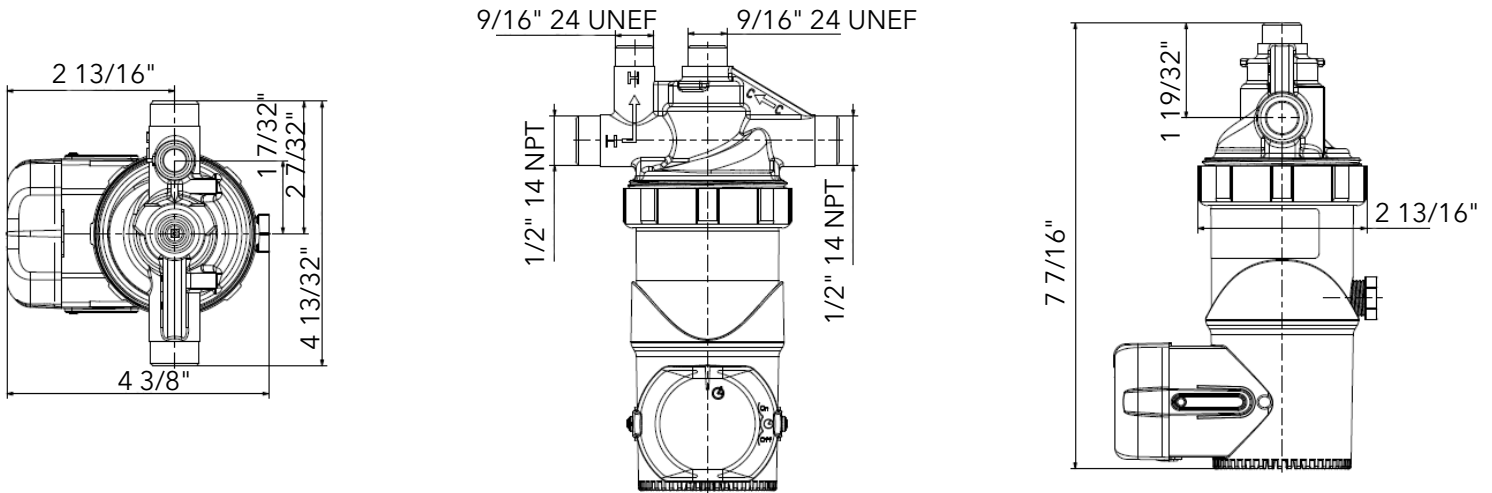

Xylem Inc.
 2881 East Bayard Street Ext., Suite A
 Seneca Falls, NY 13148
 Phone: (866) 325-4210
 Fax: (888) 322-5877
www.xylem.com/goulds

Goulds is a registered trademark of Goulds Pumps, Inc. and is used under license.
 © 2021 Xylem, Inc. BR-25B January 2021