



**Macurco™ OX-6  
Oxygen Detector, Controller and Transducer  
User Instructions**



Important: Keep these User Instructions for reference

|   |  |    |
|---|--|----|
| TABLE OF CONTENTS                       |  |    |
| GENERAL SAFETY INFORMATION              |  | 4  |
| Intended Use                            |  | 4  |
| List of Warnings and Cautions           |  | 4  |
| USE INSTRUCTIONS AND LIMITATIONS        |  | 5  |
| Use For                                 |  | 5  |
| Do Not Use For                          |  | 5  |
| General Description                     |  | 5  |
| Features                                |  | 6  |
| Specifications                          |  | 6  |
| INSTALLATION AND OPERATING INSTRUCTIONS |  | 7  |
| Location                                |  | 7  |
| Installation                            |  | 7  |
| 4-20mA Output diagram                   |  | 8  |
| Garage diagram                          |  | 9  |
| Multiple Device diagram                 |  | 9  |
| Alarm Control Panel diagram             |  | 10 |
| DVP-120 Control Panel diagram           |  | 10 |
| Alternate Alarm Panel                   |  | 11 |
| Power Up                                |  | 11 |
| Operation                               |  | 11 |
| Default – Factory Settings              |  | 12 |
| Power-Up Test setting                   |  | 13 |
| Display setting                         |  | 13 |
| Buzzer setting                          |  | 13 |
| Alarm Relay setting                     |  | 13 |
| Alarm Relay Configuration               |  | 13 |
| Fan Relay setting                       |  | 13 |
| Fan Relay Delay setting                 |  | 14 |
| Fan Minimum Runtime setting             |  | 14 |
| Fan Relay Latching setting              |  | 14 |
| Trouble Fan Setting                     |  | 14 |
| 4-20mA Output setting                   |  | 14 |
| On Board Diagnostics                    |  | 14 |
| Sensor Poisons                          |  | 15 |
| MAINTENANCE                             |  | 15 |
| End-of-Warranty Signal                  |  | 15 |
| Sensor Replacement                      |  | 16 |
| Sensor Life Reset                       |  | 16 |
| Cleaning                                |  | 17 |
| Testing                                 |  | 17 |
| Operation Test                          |  | 17 |
| Oxygen Test                             |  | 19 |
| Field Calibration Procedure             |  | 22 |
| MACURCO GAS DETECTION PRODUCTS WARRANTY |  | 24 |



## GENERAL SAFETY INFORMATION

### Intended Use

The Macurco OX-6 is a low voltage, dual relay oxygen (O<sub>2</sub>) detector, controller and transducer. The OX-6 has selectable 4-20 mA output, buzzer and digital display options. It is an electronic detection system used to measure the concentration of oxygen and provide feedback and automatic exhaust fan control to help maintain appropriate oxygen concentrations in commercial applications. The OX-6 is a low level meter capable of detecting from 0-25% by volume of oxygen. The OX-6 is factory calibrated and 100% tested for proper operation, but can also be calibrated in the field.

### List of Warnings and Cautions within these User Instructions



- Each person using this equipment must read and understand the information in these User Instructions before use. Use of this equipment by untrained or unqualified persons, or use that is not in accordance with these User Instructions, may adversely affect product performance and **result in sickness or death**.
- Use only for monitoring the gas which the sensor and instrument are designed to monitor. Failure to do so may result in exposures to gases not detectable and **cause sickness or death**. For proper use, see supervisor or User Instructions, or call Technical Service at 1-877-367-7891.
- This equipment may not function effectively below 0°F or above 125°F (-18°C or above 52°C). Using the detector outside of this temperature range may adversely affect product performance and **result in sickness or death**.
- This detector helps monitor for the presence and concentration level of a certain specified airborne gas. Misuse may produce an inaccurate reading, which means that critical levels of the gas being monitored may be present and could result in overexposure and **cause sickness or death**. For proper use, see supervisor or User Instructions, or call Technical Service at 1-877-367-7891.
- High voltage terminals (120/240 VAC) are located within this detector, presenting a hazard to service technicians. Only qualified technicians should open the detector case and service the internal circuits. Unused power is removed from the detector relays prior to servicing the unit. **Failure to do so may result in sickness or death**.
- Do not disassemble unit or attempt to repair or modify any component of this instrument. This instrument contains no user serviceable parts, and substitution of components may impair product performance and **result in sickness or death**.
- Using a certified gas with a concentration other than the one listed for this detector when conducting a calibration or calibration verification test (bump test) will produce inaccurate readings. This means that critical levels of the gas being monitored may be present and could result in overexposure and **cause sickness or death**. For proper use, see supervisor or User Instructions, or call Technical Service at 1-877-367-7891.
- The following steps must be performed when conducting a calibration or calibration verification test (bump test) to ensure proper performance of the monitor. Failure to do so may adversely affect product performance and **result in sickness or death**.
  - When performing a calibration or calibration verification test (bump test) only use certified calibration gas at the required concentration level. Do not calibrate with expired calibration gas.
  - If the instrument cannot be calibrated, do not use until the reason can be determined and corrected.
  - Do not cover or obstruct display or visual alarm
  - Ensure sensor inlets are unobstructed and free of debris



## USE INSTRUCTIONS AND LIMITATIONS



Each person using this equipment must read and understand the information in these User Instructions before use. Use of this equipment by untrained or unqualified persons, or use that is not in accordance with these User Instructions, may adversely affect product performance and **result in sickness or death.**

### Use For

The Macurco OX-6 Oxygen Detector provides oxygen detection and automatic ventilation control in wastewater treatment plants, factories, storage facilities and other commercial applications. The normal concentration of oxygen in the atmosphere is approximately 20.9% by volume. The OSHA minimum acceptable breathing air contains 19.5% oxygen. In the absence of adequate ventilation the level of oxygen can be reduced surprisingly quickly by breathing, combustion and other processes. Oxygen levels may also be depleted due to dilution by other gases such as carbon dioxide, nitrogen or helium and chemical absorption by corrosion processes and similar reactions. Alternately, increased levels of oxygen may dramatically increase the flammability of any combustible matter. If oxygen levels exceed 24% volume, even materials such as clothing which might normally just smolder may burst into flame. The risk from oxygen enrichment exists where pure oxygen is stored; for example in hospitals and industrial gas manufacturing and distribution plants. The OX-6 meets the OSHA requirements for oxygen concentration. OX-6 can be used stand alone, with the Macurco DVP-120 Detection and Ventilation Control Panel, other 12 VAC or 24 VDC fire/security panels or building automation systems.



Use only for monitoring the gas which the sensor and instrument are designed to monitor. Failure to do so may result in exposures to gases not detectable and **cause sickness or death.** For proper use, see supervisor or User Instructions, or call Technical Service at 1-877-367-7891.

### Do Not Use For

The OX-6 is not intended for use in hazardous locations or industrial applications such as refineries, chemical plants, etc. Do not mount the OX-6 where the normal ambient temperature is below 0°F or exceeds 125°F (below -18°C or above 52°C). The OX-6 mounts on a 4x4 electrical box supplied by the contractor. Do not install the OX-6 inside another box unless it has good air flow through it.



This equipment may not function effectively below 0°F or above 125°F (-18°C or above 52°C). Using the detector outside of this temperature range may adversely affect product performance and **result in sickness or death.**

### General Description

The OX-6 is a low voltage, dual relay oxygen (O<sub>2</sub>) detector and automatic ventilation controller. The OX-6 uses a microcomputer controlled, electronic system to measure the concentration of oxygen, actuate relays and provide a 4-20mA output. The OX-6 has a field replaceable, electrochemical sensor (expected life of 2+ years) and optional calibration test kit. The OX-6 is a low level meter capable of displaying from 0-25% of oxygen.



## Features

- ETL Listed to UL 61010-1 and CAN/CSA C22.2 No 61010-1
- Low level meter capable of displaying from 0-25% v/v oxygen
- The OX-6 meets OSHA standards for oxygen concentration
- Selectable fan and alarm relay activation
- 5 A SPDT fan relay controls starters of exhaust fans
- 0.5 A N.O. or N.C. alarm relay connects to warning devices or control panels
- 4-20 mA Current Loop
- OX-6 mounts on a standard 4x4 electrical box and becomes cover for the box
- Supervised system: any internal detector problem will cause the fan & alarm relay to activate
- Calibration verification test kit is available. One screw allows access for calibration or gas test

## Specifications

- Power: 3 W (max) from 12 to 24 VAC or 12 to 32 VDC
- Current @ 24 VDC: 75 mA in alarm (two relays), 50 mA (fan relay only) and 23 mA stand by
- Shipping Weight: 1 pound (0.45 kg)
- Size: 4 1/2 x 4 x 2 1/8 in. (11.4 X 10.2 X 5.4 cm)
- Color: Dark gray
- Connections: plugs/terminals
- Mounting box: (not included) 4x4 electric
- Fan relay: 5 A, 240 VAC, pilot duty, SPDT
- Fan relay actuation: selectable at "dIS" (disabled), 18, 18.1... , 20.2 (default), 20.3, 20.4 & 20.5% v/v and high 23.5 % v/v (preset)
- Fan Delay Settings of 0, 1, 3 (default), 5 and 10 minutes
- Fan Minimum Run Time settings are 0 (default), 3, 5, 10 or 15 minutes
- Fan relay latching or not latching (default) selectable
- Alarm relay: 0.5A 120 V, 60 VA
- Alarm relay actuation: selectable N.O. (default) or N.C.
- Alarm relay settings: "dIS" (disabled), 18.5, 19, 19.5 (default), 20, 20.5 and high 23.5 % v/v (preset)
- Current Loop: 4-20 mA for 0-25% v/v O<sub>2</sub>, selectable to off (default) or on
- Buzzer: 85 dBA at 10cm settable to on (default) or off
- Digital display: 3 digit LED selectable to on (default) or off
- Operating environ: 0°F to 125°F (-18°C to 52°C), 10 to 90% RH non-condensing



## INSTALLATION AND OPERATING INSTRUCTIONS

The following instructions are intended to serve as a guideline for the use of the Macurco OX-6 Oxygen Detector. It is not to be considered all-inclusive, nor is it intended to replace the policy and procedures for each facility. If you have any doubts about the applicability of the equipment to your situation, consult an industrial hygienist or call Technical Service at 1-877-367-7891.

### WARNING

This detector helps monitor for the presence and concentration level of a certain specified airborne gas. Misuse may produce an inaccurate reading, which means that critical levels of the gas being monitored may be present and could result in overexposure and **cause sickness or death**. For proper use, see supervisor or User Instructions, or call Technical Service at 1-877-367-7891.

### Location

An OX-6 is normally mounted at breathing level, about 5 feet (1.5 meters) above the floor on a wall or column in a central area where air movement is generally good. The unit, on average, can cover about 900 sq. ft. (84 sq. meters). The coverage depends on air movement within the room or facility. Extra detectors may be needed near any areas where people work or where the air is stagnant. Do NOT mount the OX-6 where the normal ambient temperature is below 0°F or exceeds 125°F (below -18°C or above 52°C).

### WARNING

High voltage terminals (120/240 VAC) are located within this detector, presenting a hazard to service technicians. Only qualified technicians should open the detector case and service the internal circuits. Ensure power is removed from the detector relays prior to servicing the unit. **Failure to do so may result in sickness or death.**

### Installation

1. The OX-6 mounts on a 4" square (or 4x4) electrical box supplied by the contractor. Do not mount the OX-6 inside another box, unless it has good air flow through it.
2. Connect the OX-6 to Class 2 power supply only. It is suggested to use a separate transformer for powering the unit or units because of possible interference's from other devices on the same power supply.
3. Connect the OX-6 to the control cables with terminal plugs. When making connections, make sure the power is off.
4. There are two terminals for Power: 12 to 24 VAC or 12 to 32 VDC, with no polarity preference.
5. There are two terminals for the dry alarm relay contacts, again with no polarity preference. The alarm relay can switch up to 0.5 A 120 V, or 60 VA. The alarm relay is activated if gas reaches or exceeds the alarm settings. See OPERATION section of these User Instructions for details on relay settings.
6. The alarm relay can be configured to normally open (default) (N.O.) or normally closed (N.C.) and will activate if the gas concentration drops below alarm set point. It will deactivate once the gas concentration exceeds the alarm set point. Note that the "disable" setting will cause the alarm relay not to engage at all.



7. The dry contact, SPDT fan relay has three terminals. The common (COM.), normally open (N.O.) and the normally closed (N.C.) contact. The fan relay can switch up to 5.0 A up to 240 VAC. See OPERATION section of these User Instructions for details on relay settings.
8. The Fan Relay can be configured for latching or non-latching (default) when activated (when the oxygen concentration drops below fan relay set point). Once latched in, power will need to be interrupted or the "TEST" button pressed to un-latch the relay condition.
9. The Fan Relay will engage if the fan setting oxygen concentration drops below the set point for longer than the Fan Relay Delay time. Unless it is configured for latching, the fan relay will disengage once both of these conditions have been met:
  - Oxygen concentration has exceeded fan setting
  - Fan Relay Run time has been exceeded

Note that the "disable" fan setting will cause the fan relay to not engage. The fan relay will engage in trouble fault condition (if the Trouble Fan Setting Option is set to "On") and will disengage once trouble fault condition is cleared.

10. The Current Loop is 4 mA at 0% v/v, 17.4 mA in clean air (20.9 v/v) and 20 mA at 25% v/v.

**Note:** Increased levels of oxygen may dramatically increase the flammability of any combustible matter. If oxygen levels rise to 23.5% v/v the Fan Relay and Alarm Relay will be activated. This is a preset function and is not selectable.

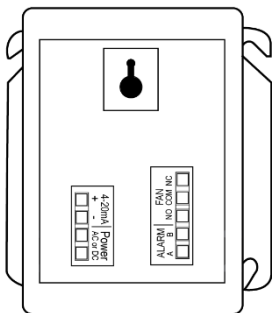
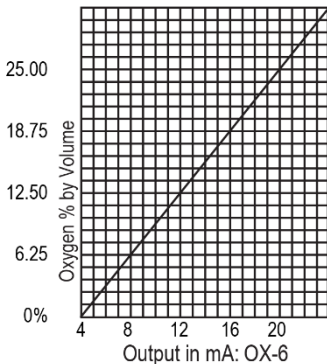

OX-6 rear view with modular connectors

## Typical layout in small garage

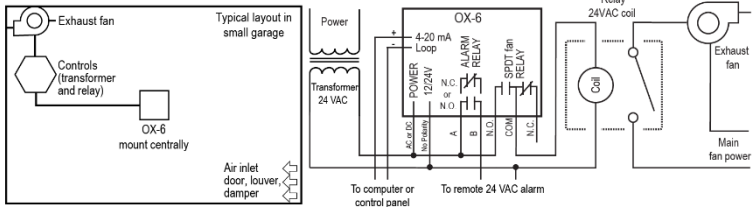

## Typical multiple OX-6 installation

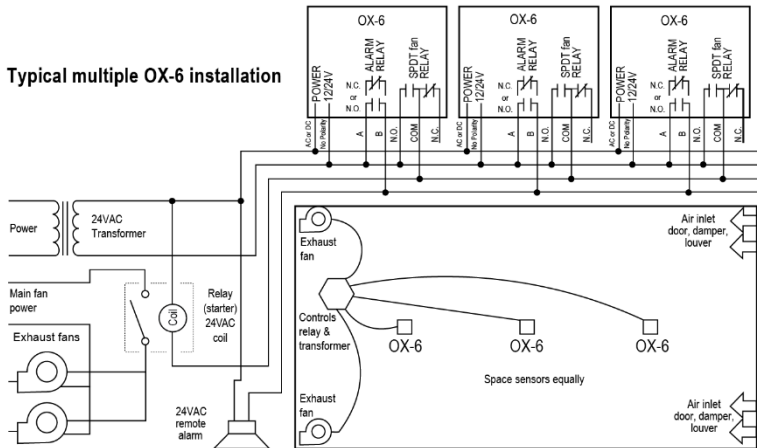



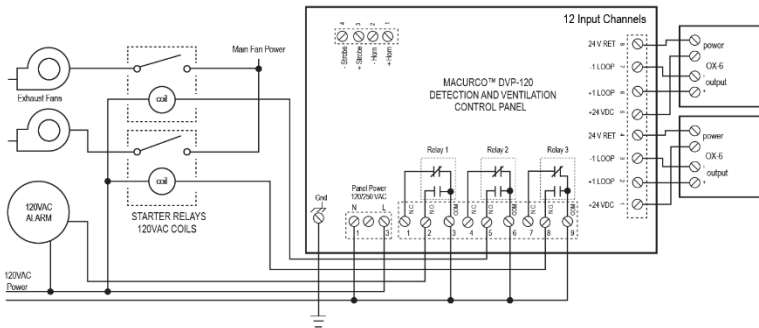
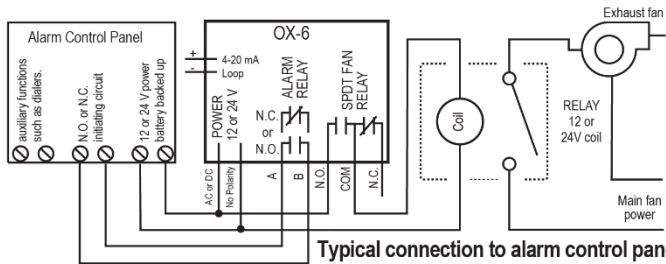

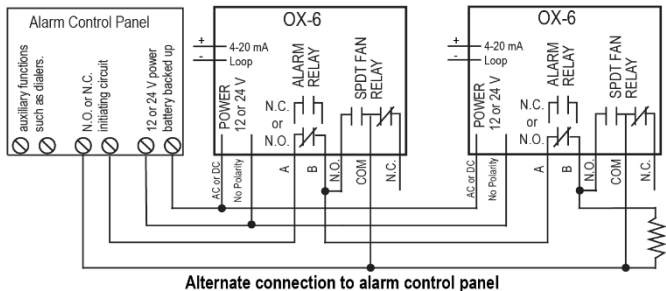

In this application (above) the Fan or primary relay is used as a low level alarm relay. The Alarm or secondary relay is used as a supervisory relay when utilized in the normally closed configuration. The OX-6 monitors all critical functions of the unit through software diagnostics that continually test and verify its operations. If a problem is found, the unit will switch to a fail-safe/error mode or trouble condition. In this error mode the Fan\* and Alarm relays will be activated indicating the trouble condition at panel and the OX-6 display will flash the error. \*See the Trouble Fan Setting Option.

### Power Up

The OX-6 steps through an internal self-test cycle for the first 1 minute that it is powered. The unit will execute the test cycle any time power is dropped and reapplied (i.e. power failure). During the self-test cycle the unit will display the Firmware Version number and the gas type, then count down from 60 to 0 (if the display option is "On") and finally go into normal operation. The alarm relay will be activated for 10 seconds and the fan relay for 60 seconds during the power-up cycle unless the "Power Up Test" (PUT) option is OFF. The indicator light (LED) will flash green during the self-test cycle. At the end of the 1 minute cycle, the unit will take its first sample of the air and the indicator light will turn solid green.

### Operation

1. With the display function turned "On", the OX-6 will show the current concentration of O<sub>2</sub> % v/v or "20.9" in normal air. When the O<sub>2</sub> concentration reaches the Fan Relay setting (20.5%, for example) the display will flash back and forth between "FAn" and "20.5". With the display function turned "OFF", the display does not show the gas concentration, but will show "FAn" as long as the fan relay is activated.
2. With the display function turned "On" and the O<sub>2</sub> concentration reaching the Alarm Relay setting, (19.5%, for example) the display will flash back and forth between "ALr" and "19.5". The buzzer will sound indicating "Alarm" if the buzzer is turned "On". With the display function turned off the display does not show the O<sub>2</sub> concentration, but will show "ALr" when the Alarm relay is activated.
3. With the 4-20 mA function turned "On" and the O<sub>2</sub> concentration climbing the 4-20 mA signal will ramp up corresponding to the concentration (0-25% v/v).

## Default Configuration – Factory Settings

- The default **Power Up Test** setting is **ON**
- The default **Display** setting is **ON**
- The default **Buzzer** setting is **ON**
- The default **Alarm Relay Setting** is activation at **19.5% v/v**
- The default **Alarm Relay Configuration** is **Normally Open**
- The default **Fan Relay Setting** is activation at **20.2% v/v**
- The default **Fan Relay Delay** setting is **3 minutes**
- The default **Fan Relay Runtime** setting is **0 minutes**
- The default **Fan Relay Latching** condition is **OFF**
- The default **Trouble Fan Setting** condition is **OFF**
- The default **4-20mA Output** setting is **ON**

To change settings, remove the Philips screw on the front of the OX-6. Pull off the front cover of the unit.

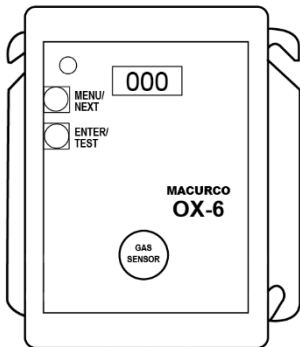

## Selecting Default Configuration – “dEF”

To select the Default Configuration, in normal mode, push the **Next** button to get to “Con” or the Configuration menu. Then push the **Enter** button to enter the Con menu. The **first** selection is the “dEF” or Default setting. Push **Enter**. If it is already in Default configuration, there will be no action. If it is not already in Default configuration, “nO” will be displayed. Push **Next** to change it to “yES” (flashing) then push **Enter** to confirm the change (solid) and push **Enter** again to return to “dEF” in the con menu. Push **Next** until “End” is displayed then push **Enter** to get back to normal operation.

#### Selecting Power Up Test Option – “PUt”

To select the **Power Up Test** Configuration, in normal mode, push the **Next** button to get to “Con” or the Configuration menu. Then push the **Enter** button to enter the Con menu. Then push the **Next** button to get to the **second selection** “PUt” or **Power Up Test** setting. Push **Enter**. If the test is “On” push **Next** to turn it “OFF” (flashing) then push **Enter** to confirm the change (solid) and push **Enter** again to return to “PUt” in the Con menu. Push **Next** until “End” is displayed then push **Enter** to get back to normal operation.

#### Selecting Display Option – “dSP”

To select the Display Configuration, in normal mode, push the **Next** button to get to “Con” or the Configuration menu. Then push the **Enter** button to enter the Con menu. Then push the **Next** button to get to the **third selection** “dSP” or Display setting. Push **Enter**. If the display is “On” push **Next** to turn it “OFF” (flashing) then push **Enter** to confirm the change (solid) and push **Enter** again to return to “dSP” in the Con menu. Push **Next** until “End” is displayed then push **Enter** to get back to normal operation.

#### Selecting Buzzer Option – “bUZ”

To select the Buzzer Configuration, in normal mode, push the **Next** button to get to “Con” or the Configuration menu. Then push the **Enter** button to enter the Con menu. The **fourth selection** is the “bUZ” or Buzzer setting. Push **Next** three times to get to “bUZ” then **Enter**. If the display is “On” push **Next** to turn it “OFF” (flashing) then push **Enter** to confirm the change (solid) and push **Enter** again to return to “bUZ” in the Con menu. Push **Next** until “End” is displayed then push **Enter** to get back to normal operation.

#### Selecting Alarm Relay Setting – “ArS”

To select the Alarm Relay Setting, in normal mode, push the **Next** button to get to “Con” or the Configuration menu. Then push the **Enter** button to enter the Con menu. The **fifth selection** is the “ArS” or Alarm Relay Setting. Push **Next** four times to get to “ArS” then **Enter**. If the display is “dIS” (disabled) push **Next** to change it to 18.5, 19, 19.5, 20 or 20.5% v/v (flashing) then push **Enter** to confirm the change (solid) and push **Enter** again to return to “ArS” in the Con menu. Push **Next** until “End” is displayed then push **Enter** to get back to normal operation.

#### Selecting Alarm Relay Configuration – “Arc”

To select the **Alarm Relay Configuration**, in normal mode, push the **Next** button to get to “Con” or the Configuration menu. Then push the **Enter** button to enter the Con menu. The **sixth selection** is the “Arc” or Alarm Relay Configuration. Push **Next** five times to get to “Arc” then **Enter**. If the relay is “nO” (normally open) push **Next** to turn it to “nC” (flashing) then push **Enter** to confirm the change (solid) and push **Enter** again to return to “Arc” in the Con menu. Push **Next** until “End” is displayed then push **Enter** to get back to normal operation.

#### Selecting Fan Relay Settings – “FrS”



To select the Fan Relay setting, in normal mode, push the **Next** button to get to "Con" or the Configuration menu. Then push the **Enter** button to enter the Con menu. **The seventh selection** is the "FrS" or Fan Relay setting. Push **Next** six times to get to "FrS" then **Enter**. If the fan relay is "dIS" (disabled) push **Next** to change it to 18, 18.1, 18.2, 18.3, 18.4, 18.5, 18.6, 18.7, 18.8, 18.9, 19, 19.1, 19.2, 19.3, 19.4, 19.5, 19.6, 19.7, 19.8, 19.9, 20, 20.1, 20.2, 20.3, 20.4 or 20.5% v/v (flashing) then push **Enter** to confirm the change (solid) and push **Enter** again to return to "FrS" in the Con menu. Push **Next** until "End" is displayed then push **Enter** to get back to normal operation.

#### Selecting Fan Relay Delay – "Frd"

To select the Fan Relay Delay setting, in normal mode, push the **Next** button to get to "Con" or the Configuration menu. Then push the **Enter** button to enter the Con menu. **The eighth selection** is the "Frd" or Fan Relay Delay. Push **Next** seven times to get to "Frd" then **Enter**. If the delay is "0" (disabled) push **Next** to change it to 1, 3, 5, or 10 minutes (flashing) then push **Enter** to confirm the change (solid) and push **Enter** again to return to "Frd" in the Con menu. Push **Next** until "End" is displayed then push **Enter** to get back to normal operation.

#### Selecting Fan Relay Run Time – "Frr"

To select the Fan Minimum Runtime setting, in normal mode, push the **Next** button to get to "Con" or the Configuration menu. Then push the **Enter** button to enter the Con menu. **The ninth selection** is the "Frr" or Fan Minimum Run Time. Push **Next** eight times to get to "Frr" then **Enter**. If the runtime is "OFF" (disabled) push **Next** to change it to 3, 5, 10 or 15 minutes (flashing) then push **Enter** to confirm the change (solid) and push **Enter** again to return to "Frr" in the Con menu. Push **Next** until "End" is displayed then push **Enter** to get back to normal operation.

#### Selecting Fan Relay Latching Option – "FrL"

To select the **Fan Relay Latching Option**, in normal mode, push the **Next** button to get to "Con" or the Configuration menu. Then push the **Enter** button to enter the Con menu. **The tenth selection** is the "FrL" or Fan Relay Latching Option. Push **Next** nine times to get to "FrL" then **Enter**. If latching is "OFF" push **Next** to turn it to "On" (flashing) then push **Enter** to confirm the change (solid) and push **Enter** again to return to "FrL" in the Con menu. Push **Next** until "End" is displayed then push **Enter** to get back to normal operation.

#### Selecting Trouble Fan Setting Option – "tFS"

To select the **Trouble Fan Setting Option**, in normal mode, push the **Next** button to get to "Con" or the Configuration menu. Then push the **Enter** button to enter the Con menu. **The eleventh selection** is the "tFS" or Trouble Fan Setting Option. Push **Next** ten times to get to "tFS" then **Enter**. If Trouble Fan Setting is "OFF" push **Next** to turn it to "On" (flashing) then push **Enter** to confirm the change (solid) and push **Enter** again to return to "tFS" in the Con menu. Push **Next** until "End" is displayed then push **Enter** to get back to normal operation.

#### Selecting 4-20mA Output Option – "420"

To select the **4-20mA Output Option**, in normal mode, push the **Next** button to get to "Con" or the Configuration menu. Then push the **Enter** button to enter the Con menu. **The twelfth selection** is the "420" or 4-20mA Output Option. Push **Next** eleven times to get to "420" then **Enter**. If the 4-20mA is "On" push **Next** to turn it to "OFF" (flashing) then push **Enter** to confirm the change (solid) and push **Enter** again to return to "420" in the Con menu. Push **Next** until "End" is displayed then push **Enter** to get back to normal operation.

### Onboard Diagnostics



The OX-6 monitors all critical functions of the unit through software diagnostics that continuously test and verify unit operations. If a problem is found, the unit will switch to a fail-safe/error mode or trouble condition. In this error mode, the Alarm relay will be activated, the 4-20 mA current loop will go to 24 mA, the unit will display the error code, the green status indicator LED light will flash and the buzzer will chirp intermittently. The Fan relay will also engage if the Trouble Fan Setting Option is set to "On". This is a safety precaution. To clear this mode, simply turn off power to the unit for a few seconds, or push the ENTER/TEST switch (inside the unit). This will cause the unit to restart the 1 minute self-test cycle.

#### The 4-20 mA signal can be used for troubleshooting:

- 0 mA is most likely a connection problem
- 4-20 mA is normal gas reading range (0-25% v/v)
- 24 mA indicates a Trouble condition

#### Error Codes

- |        |                                  |
|--------|----------------------------------|
| • t01  | Sensor missing                   |
| • t02  | Temperature compensation failure |
| • t04  | EEPROM bad checksum              |
| • t10  | Bad EEPROM                       |
| • t20  | Bad calibration                  |
| • t40  | Factory calibration failure      |
| • t80  | Read ADC failure                 |
| • t100 | Under range                      |
| • t200 | Sensor warranty expired          |

**Note:** For trouble codes over 080 the display will alternate between t\_1 and t00 for t100 and between t\_2 and t00 for t200.

If the error mode repeats frequently, check for continuous power and proper voltage. If power is not the problem and a unit has repeating error conditions, it may need to be returned to Macurco for service, per these User Instructions.

If the error mode indicates "Sensor warranty expired" see the **Sensor Replacement** section of these User Instructions.

#### Sensor Poisons

The gas sensor in the detector is designed with extreme sensitivity to the environment. As a result, the sensing function may be deteriorated if it is exposed to a direct spray from aerosols such as paints, silicone vapors, etc., or to a high density of corrosive gases (such as hydrogen sulfide, sulfur dioxide) for an extended period of time.

#### MAINTENANCE



The OX-6 requires periodic maintenance. The unit uses an electrochemical sensor with a 2-3 year life expectancy that can be tested, calibrated and replaced in the field. The OX-6 replacement sensor is available through your local representative or from Macurco. The detector's performance should be tested regularly by using gas as detailed in the Testing and Field Calibration sections. All other maintenance and repair of products manufactured by Macurco are to be performed at the appropriate Macurco manufacturing facility. Macurco does not sanction any third-party repair facilities.

### End-of-Warranty Signal

Two years after the OX-6 is installed the sensor end-of-warranty signal will be activated indicating that the OX-6 sensor has reached the end of its warranty period. The end-of-warranty signal will cause an error code t200 "Sensor warranty expired". See Error Codes section. In addition to the end-of-warranty signal the sensor itself has a tamper proof warranty expiration sticker dated 2 years from the unit manufacture date. See the Macurco Fixed Gas Detection Products Limited Warranty section.

The end-of-warranty signal can be silenced for 48 hours by pressing the "ENTER/TEST" button or by temporarily dropping power to the unit. The end-of-warranty signal provides the user an opportunity to test and/or calibrate the sensor assuring that it is still performing within acceptable parameters though the sensor is nearing the end of its 2-3 year expected life. The silence function will continue to be available for 29 days after the OX-6 initiates the initial end-of-warranty signal. After this 29 day period the OX-6 can no longer be silenced and the sensor must be replaced or the sensor life reset.

### Sensor Replacement

1. Remove power to the unit
2. Remove the Philips screw on the front of the OX-6. Pull the front cover of the unit off.
3. Remove the sensor by pulling it gently from the three pronged socket.
4. Power up the unit. The OX-6 steps through an internal self-test cycle for the first 1 minute that it is powered. During the self-test cycle the unit will display the Firmware Version number, then count down from 60 to 0 and finally go into normal operation. The indicator light (LED) will flash green during the self-test cycle. At the end of the 1 minute cycle, the unit will take its first sample of the air and the indicator light will turn solid green.
5. Let the new sensor stabilize for at least 20 minutes then refer to the **FIELD CALIBRATION PROCEDURE** section to calibrate the unit.
6. After the successful calibration is complete, reset the sensor life.

### Sensor Life Reset

1. Remove the Philips screw on the front of the OX-6. Pull the front cover of the unit off.
2. To reset the sensor life (**rSt**), from normal or warm-up mode, press the **Next** button four times to get to **SEn** or **Sensor Mode**.
3. Then press the **Enter** button to get to "**rSt**" - Reset Sensor Mode.
4. Press the **Enter** button again to see the sensor reset status. If the sensor life has already been reset, done "**don**" will be displayed. If it has not already been reset, "**no**" will be displayed. Push **Next** to change it to "**yES**" (flashing) then push **Enter** to confirm the



change (solid) and push **Enter** again to return to "rSt" in the SEn menu. Push **Next** until "End" is displayed then push **Enter** to get back to normal operation.

**Note:** If the sensor is reset and not replaced it is necessary to test and/or calibrate the sensor to assure that it is still performing within acceptable specifications though the sensor is nearing the end of its 2-3 year expected life. There will be no other indication of sensor performance.

## **WARNING**

Do not disassemble unit or attempt to repair or modify any component of this instrument. This instrument contains no user serviceable parts, and substitution of components may adversely affect product performance and **result in sickness or death.**

### **CAUTION**

Avoid the use of harsh cleaning materials, abrasives and other organic solvents. Such materials may permanently scratch the surfaces and damage the display window, labels, sensor or instrument housing. High voltage terminals (100-240VAC) are located within this detector, presenting a hazard to service technicians. Only qualified technicians should open the detector case and service the internal circuits. Ensure power is removed from the detector prior to cleaning the unit. Failure to do so may result in sickness or death.

### **Cleaning**

Cleaning of the external surfaces is best carried out using a damp cloth with a mild detergent or soap. Use a vacuum cleaner with soft brush to remove dust or contamination under the cover. Do not blow out the sensor with compressed air.

### **TESTING**

## **WARNING**

Using a certified gas with a concentration other than the one listed for this detector when conducting a calibration or calibration verification test (bump test) will produce inaccurate readings. This means that critical levels of the gas being monitored may be present and could result in overexposure and **cause sickness or death.** For proper use, see supervisor or User Instructions, or call Technical Service at 1-877-367-7891.

### **General**

All OX-6 units are factory calibrated and 100% tested for proper operation. During normal operation the green status indicator LED light will be on steady, the fan & alarm relay will be in standby mode and the 4-20 mA output will be at 4mA (in clean air). The unit also performs a regular automatic self-test during normal operation. If the unit detects an improper voltage or inoperable component, it will default into Error mode. In this error mode, the Alarm relay will be activated, the 4-20 mA current loop will go to 24 mA, the unit will display the error code, the green status indicator LED light will flash and the buzzer will chirp intermittently. The Fan relay will also engage if the Trouble Fan Setting Option is set to "On".

### **Operation Test**





Check that the green OX-6 status indicator LED light is illuminated continuously. If not, do not proceed with the tests. If the unit is in error mode contact your local representative or Macurco technical service representative for information on resolving the problem.

1. Remove the single screw in the middle of the front cover of the OX-6.
2. Remove the front cover.
3. Observe the LED light on the front of the OX-6.
4. If the light is solid green proceed to step 6.
5. If the green status indicator LED light is off or flashing, refer to the General section above.
6. Locate the switch labeled ENTER/TEST on the left side of the printed circuit board. Press the Test switch once.
7. The OX-6 will step through a cycle test:
  - a. The display progresses through the **bUZ** (buzzer Test) **Art** (alarm relay test), **Frnt** (fan relay test) then **42t** (4-20 mA output test). Make sure that the settings are "On" or not disabled "diS".
  - b. During the first 10 seconds of the test cycle, the display will show bUZ and set off the audible buzzer
  - c. The alarm relay will be closed, so any devices connected to that relay will be tested.
  - d. The Fan relay will be activated for the next 1 minute of the test, so if the fan circuits are wired in the normal manner, the fan should run.
  - e. The 4-20mA output will then ramp up from 4 to 16 mA over the next 130 seconds of the test, so if the circuit is wired in the normal manner, the control panel or building automation system should respond.
  - f. At the end of the test cycle, the light will turn green and be on steady (Normal Operation), the fan & alarm relay will be in standby mode and the 4-20 mA output will return to 17.4 mA (in clean air).
8. When testing is completed reassemble the unit or units.

## Manual Operation Test

This option gives the user the opportunity to manually initiate an individual test for each relay, the analog output and the sensor response to gas. From normal operation mode press the **Next** button 2 times to get to the Test Mode (tSt). Press the **Enter** button once to get into the Test Menu. Press the **Next** button to scroll through the five test options and press **Enter** to initiate the selected test. Note that if the relay or 4–20 mA output has been disabled, the test selection will not be displayed in the test menu.

**bUZ** – Buzzer Test, 3 seconds

**Art** - Alarm Relay Test, 10 seconds

**Frnt** - Fan Relay Test, 60 seconds

**42t** - 420 loop test, 130 seconds

**gSt** - Gas Test, 3 minutes (no output to the panel during the gas test)



The display will flash during the test, or in the case of the gas test, the gas level will alternate with gtS. Once the test is complete, the display will return to steady display. To exit the test menu, press the **Next** button until "End" is displayed, then press **Enter** to return to normal mode.

## Oxygen Gas Test



### WARNING

The following steps must be performed when conducting a calibration or calibration verification test (bump test) to ensure proper performance of the monitor. Failure to do so may adversely affect product performance and **result in sickness or death.**

- When performing a calibration or calibration verification test (bump test) only use certified calibration gas at the required concentration level. Do not calibrate with expired calibration gas.
- If the instrument cannot be calibrated, do not use until the reason can be determined and corrected.
- Do not cover or obstruct display or visual alarm cover.
- Ensure sensor inlets are unobstructed and free of debris

## General

The OX-6 can be bump-tested with the OX-FTK with oxygen gas, regulator and test hood, available through your local representative or from Macurco.

## Contents of the FTK

- OX-FTK: (1) Gas Cylinder, 17.0% v/v oxygen gas in air
- Gas regulator with about two feet of plastic tubing
- Gas test hood

## FTK Information

Several detectors can be tested with one FTK. The only limitation is the amount of gas in the cylinder and the flow of the regulator. The 34 liter cylinder for example with a 0.2LPM regulator has approximately 170 minutes of continuous calibration run time. Replacement cylinders are available. The gas cylinder should be replaced when the pressure gauge on the regulator shows 25-psi or less.

**Note:** For optimum test results it is suggested that the unit be in clean air (green light on) and be in a low ambient air flow.

## Gas Testing

### Testing the Fan Relay

1. Remove the Philips screw on the front of the OX-6. Remove the front cover.
2. Open the FTK. Connect the 17.0% v/v gas cylinder to the regulator.



3. Check the pressure gauge on the regulator. If you have 25-psi or less you will need to replace the gas canister.
4. Assemble regulator, hose and test hood and place the test hood over the gas sensor.

**Note:** The time to activate the Fan relay depends on the delay setting.

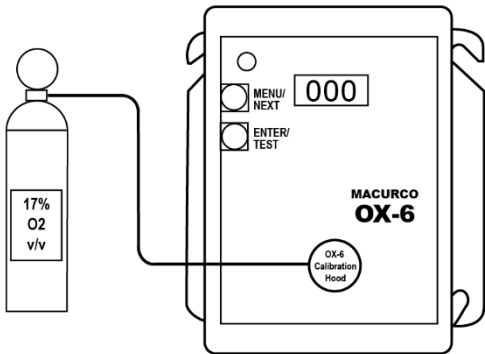

5. Turn on the regulator to start the gas flow and wait with the gas applied continuously.
6. With the display function turned "On", the OX-6 will show the current concentration of gas or "20.9" (% v/v) in clean air. When the gas concentration reaches the Fan Relay setting (20.2% v/v, for example) the display will flash back and forth between "FAn" and "20.2". With the display function turned "OFF", the display does not show the gas concentration, but will show "FAn" as long as the fan relay is activated.

**Note:** If the Fan relay does not close within 2 minutes, there are five possibilities:

- a. Gas cylinder is empty, check the pressure gauge. Replace the gas cylinder if 25psi or less.
  - b. Unit needs to be re-calibrated (go through recalibration and re-test).
  - c. Detector has fan relay set to disable (OFF). Set fan relay to 20.2% v/v and repeat the test.
  - d. Detector has fan relay delay set to 3 minutes or higher. Set fan relay to 0 minutes and repeat the test.
  - e. Detector is in need of servicing (return unit to factory for servicing).
7. Remove the gas from the sensor. Proceed to Test the Alarm relay or replace the top cover. Fan relay test is complete.



## Testing the Alarm Relay

**Note:** The gas concentration to activate the Alarm relay depends on the setting.

1. Connect the 17.0% v/v cylinder of oxygen to the regulator.
2. Check the pressure gauge. If there is 25psi or less the cylinder should be replaced.
3. Place the test hood over the gas sensor. Turn on the regulator to start the gas flow.
4. The Fan relay should activate according to the settings.
5. With the display function turned "On" and the gas concentration reaching the Alarm Relay setting, (19.5% v/v, for example) the display will flash back and forth between "ALr" and "19.5". The buzzer will sound indicating "Alarm" if the buzzer is turned "On". With the display function turned off the display does not show the gas concentration, but will show "ALr" when the Alarm relay is activated.

**Note:** If the Alarm relay fails to operate within 2 minutes, there are four possibilities:

- a. Gas cylinder is empty, check the pressure gauge. Replace the gas cylinder if 25-psi or less.
  - b. Unit needs to be re-calibrated (go through recalibration and re-test).
  - c. Detector has Alarm relay set to disable (OFF). Set Alarm relay to 19.5% v/v and repeat the test.
  - d. Detector is in need of servicing (return unit to factory for servicing).
6. Remove the gas from the sensor after Test. Proceed to Test the 4-20mA output or replace the top cover. Alarm relay test is complete.

## Testing the 4-20mA current loop

1. Connect the 17.0% v/v cylinder of oxygen to the regulator.
2. Check the pressure gauge. If there is 25-psi or less the cylinder should be replaced.
3. Place the test hood from the regulator over the gas sensor. Turn on the regulator to start the gas flow.
4. The Fan relay should activate according to the settings.
5. The Alarm relay should activate according to the settings.
6. The 4-20 mA output should decrease from 17.4 mA in clean air (20.9% v/v) to 14.9 mA at 17.0% v/v. See 4-20 mA diagram on page 8.

**Note:** If the 4-20mA output does not decrease within 2 minutes, there are four possibilities:

- a. Gas cylinder is empty, check the pressure gauge. Replace the gas cylinder if 25-psi or less.
- b. Unit needs to be re-calibrated (go through recalibration and re-test).
- c. Detector has 4-20 mA option set to "OFF". Set 4-20mA option to "On" and repeat the test.
- d. Detector is in need of servicing (return unit to factory for servicing).



7. Remove the gas from the sensor. Re-assemble the OX-6 (make sure the LED is aligned with the front case hole). 4-20 current loop test is complete.

## FIELD CALIBRATION PROCEDURE

**Note:** For optimum calibration results the unit **must be in clean air** and be in a low ambient air flow.

### Calibrating the Sensor to Clean Air

1. Remove the Philips screw on the front of the OX-6. Pull the front cover of the unit off.
2. To select Calibration Mode (CAL) from normal mode, press the **Next** button three times to get to **CAL or Calibration Mode**.
3. Then press the **Enter** button to get to "**SPn**" - Calibration Span Mode. The unit will display the current oxygen reading (% v/v) alternating with **SPn** (blinking) indicating calibration in progress (max 165 sec).
4. If the process is successful, the display will read **20.9** alternating with **PAS** (blinking) Calibration complete.
5. If the process was not successful the display will read the current oxygen reading (% v/v) alternating with **FAL (Fail)** (blinking) Calibration Failed. If this occurs, repeat steps 2 through 4. If the sensor fails to calibrate twice contact Technical Assistance: 1-877-367-7891.
6. To return to Normal Mode press **Enter** and then press **Next** until "20.9" or the current reading is displayed, or the unit will simply time out to CAL then normal mode.
7. Re-assemble the OX-6 (make sure the LED is aligned with the front case hole). Calibration is complete.
8. See Calibration Flowchart on the inside of the housing.



## MACURCO FIXED GAS DETECTION PRODUCTS LIMITED WARRANTY

Macurco warrants the OX-6 gas detector will be free from defective materials and workmanship for a period of two (2) years from date of manufacture (indicated on the inside cover of the OX-6), provided it is maintained and used in accordance with Macurco instructions and/or recommendations. If any component becomes defective during the warranty period, it will be replaced or repaired free of charge, if the unit is returned in accordance with the instructions below. This warranty does not apply to units that have been altered or had repair attempted, or that have been subjected to abuse, accidental or otherwise. The above warranty is in lieu of all other express warranties, obligations or liabilities. THE IMPLIED WARRANTIES OF MERCHANTABILITY AND FITNESS FOR PARTICULAR PURPOSE ARE LIMITED TO A PERIOD OF TWO (2) YEARS FROM THE PURCHASE DATE. Macurco shall not be liable for any incidental or consequential damages for breach of this or any other warranty, express or implied, arising out of or related to the use of said gas detector. Manufacturer or its agent's liability shall be limited to replacement or repair as set forth above.

Buyer's sole and exclusive remedies are return of the goods and repayment of the price, or repair and replacement of non-conforming goods or parts.

### Macurco Inc.

1504 W 51st St.  
Sioux Falls, SD 57105

### Technical Support Contact Information

Phone: 1-844-325-3050  
Fax: 1-605-951-9616  
Email: [support@macurco.com](mailto:support@macurco.com)  
Website: [www.macurco.com/support/](http://www.macurco.com/support/)

REV – 1.0.0  
Issue Date: 1.18.2023  
Document No: 34-2900-0009-7  
© Macurco 2023. All rights reserved.

**MACURCO**  
GAS DETECTION

### General Contact Information

Phone : 1-877-367-7891  
Fax : 1-605-951-9616  
Email: [info@macurco.com](mailto:info@macurco.com)  
Website: [www.macurco.com](http://www.macurco.com)

