

# SEFINA PRESSURE BALANCE SHOWER TRIM

SKU: 953986

Code: SHSF8010, SH4001



## FEATURES

Material: Metal  
Length: 7-5/16"  
Width: 3-15/16"  
Height: 7-5/16"  
Assembly Required: No  
Handle Type: Lever  
Handle Length: 2-13/16"  
Diverter Included: No

ASME A112.18.1/CSA B125.1

ASSE 1016 Type P

Massachusetts Accepted



REVISED 4/11/2024

# SEFINA PRESSURE BALANCE SHOWER TRIM

SKU: 953986

Code: SHSF8010, SH4001



## ADDITIONAL FEATURES

- Metal construction for ultimate strength and durability.
- May purchase with or without valve. Value required for use. (SH4001)
- When purchased with Rough-in Valve:
  - Pressure balance valve with integral stops.
  - One-piece cartridge design for ease of maintenance.
  - Back-to-back capability.
  - Ceramic disc valve cartridge.
  - Cast bronze valve body.
  - Adjustable temperature limit stop.
  - Quick remove plaster guard.
  - Easy mounting brackets.

REVISED 4/11/2024

# SEFINA PRESSURE BALANCE SHOWER TRIM

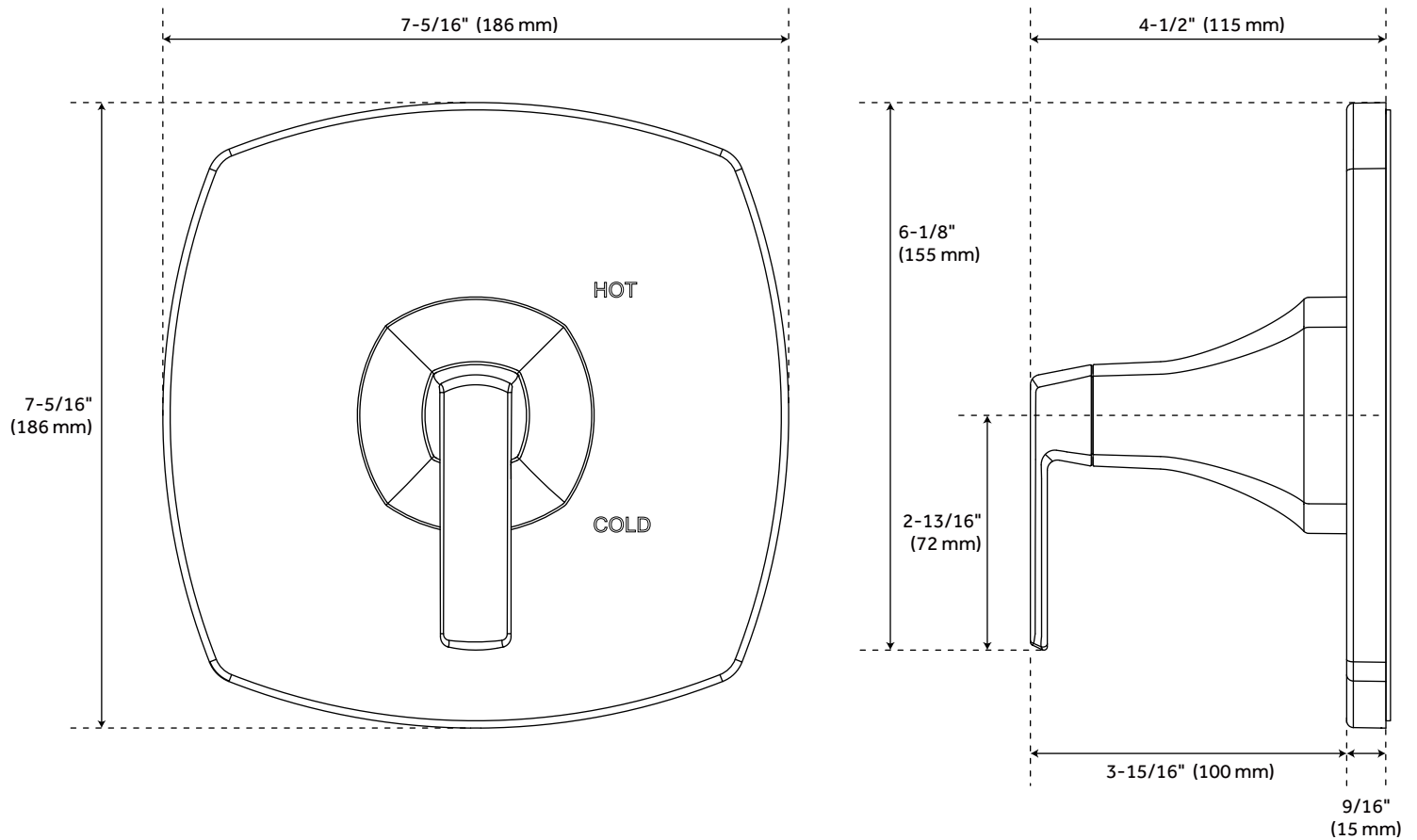

All dimensions and specifications are nominal and may vary. Use actual products for accuracy in critical situations.

# SEFINA OPTIONAL PRESSURE BALANCE ROUGH-IN VALVE

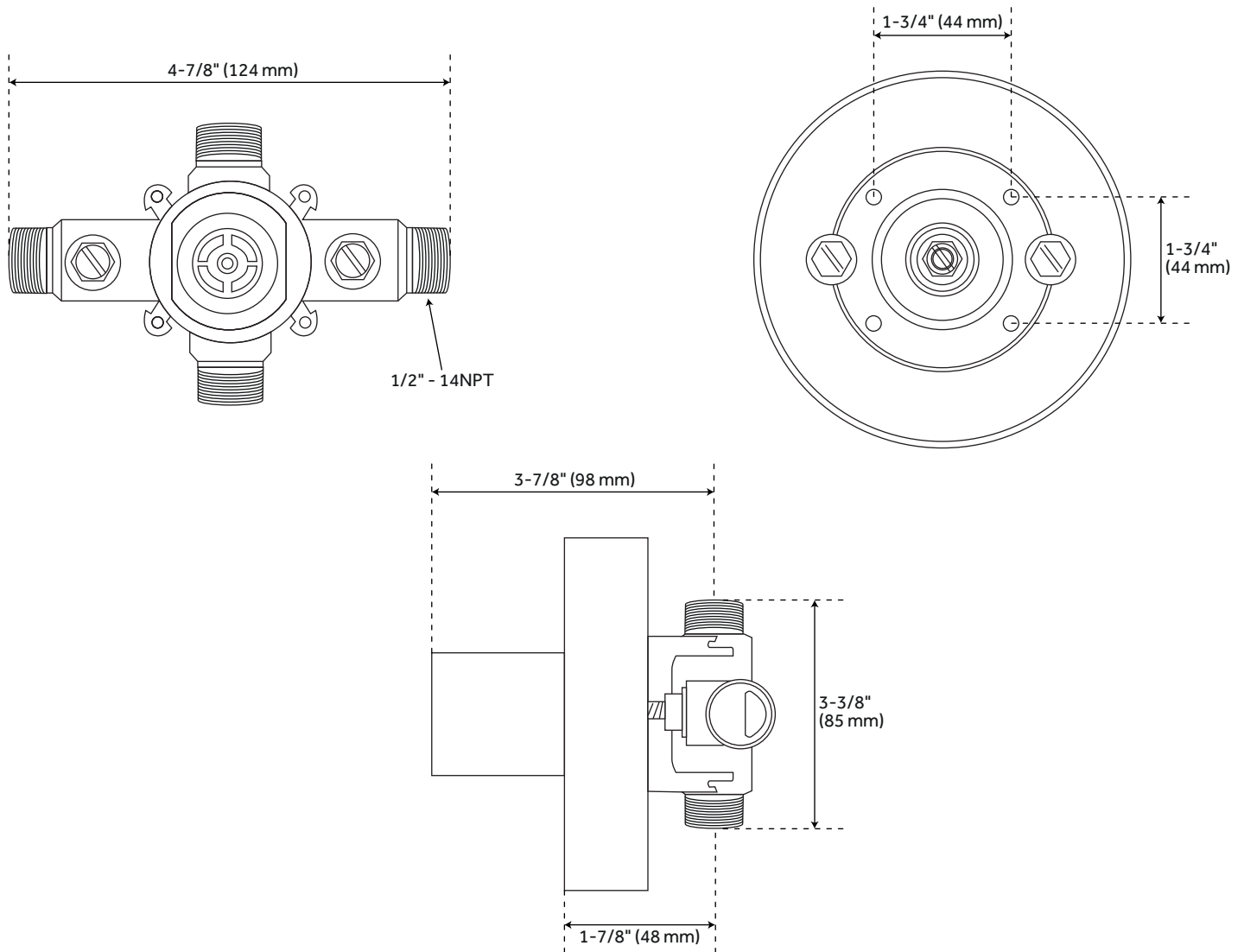

All dimensions and specifications are nominal and may vary. Use actual products for accuracy in critical situations.