

Decorator Door Chimes

**LB-46, LD-49, LA-58, LA-70MA,
& LA-151WM SERIES**

Your NuTone Door Chime is designed for three (3) door operation. It will sound either 8 or 4 notes for the front door, one (1) note for a second door and a different note for a third door. Use the NuTone transformer packaged with the chime for best results.

When installing this chime and wiring has been completed, check to make sure that the pushbuttons are in good operating condition. When installed correctly, they must not stick – meaning they must return to the original position to open the circuit.

HELPFUL HINTS – This chime is "protection packed". Handle carefully as you would any precision instrument. Comply with local wiring codes when wiring the chime. Upon completion of the installation, if the chime does not operate, recheck your installation with these instructions and wiring diagram. If the chime still does not operate, check the pushbutton(s) for poor contact or loose connections.

INSTALLATION

Select a central location to insure an audible signal throughout the home. For a large ranch-style or multi-story home, two chimes may be needed. Refer to Figures 2 and 3 for Multiple Chime Wiring Information.

WIRING

NOTE: BE SURE HOUSE POWER IS TURNED OFF WHEN INSTALLING THE TRANSFORMER.

1. Mount the transformer to a convenient junction box (attic location is not recommended) or circuit breaker box. Connect the transformer leads to house power leads: black to black and white to white.

IMPORTANT: All wiring connections must comply with national or local codes. Run two conductor, 18 gauge wire from the transformer and pushbuttons to the chime location. Bring wires through wiring access hole in the chime baseplate and fasten the baseplate to the wall with screws provided. Connect wires to chime terminal board as illustrated in Figure 1. For two chime installation refer to Figure 2. For one chime with one two-note chime, refer to Figure 3.

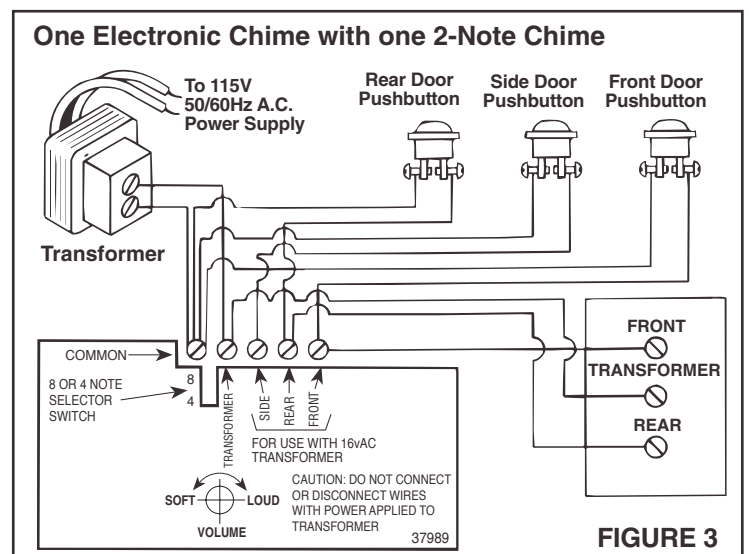
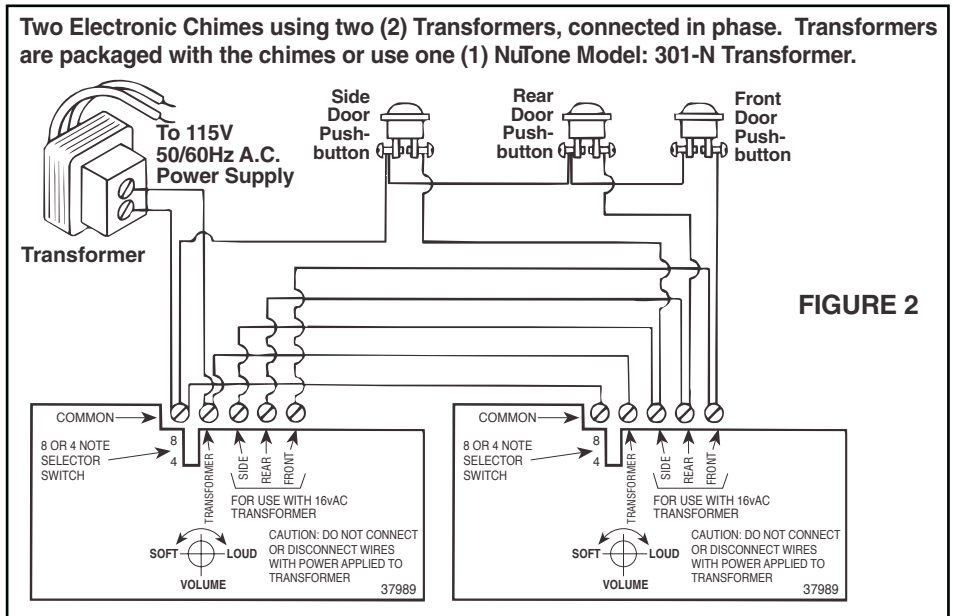
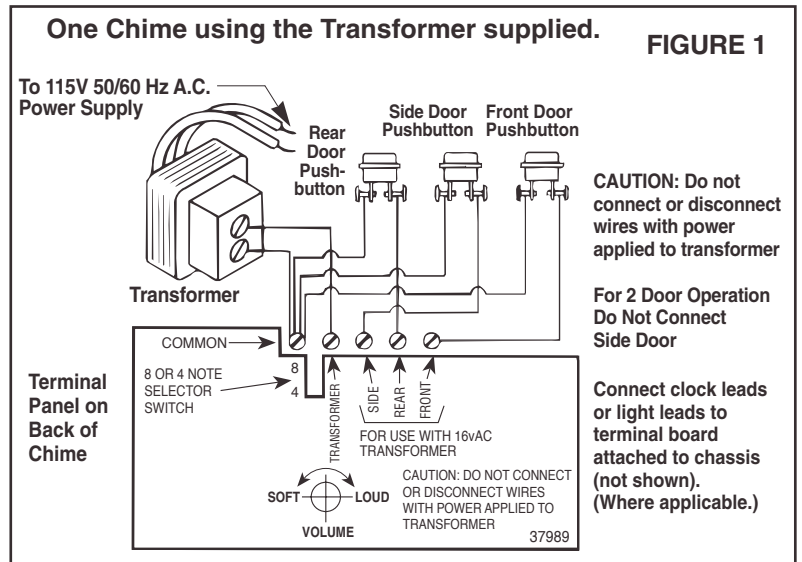

WIRING, continued

Clock Model

Connect clock leads to lugs provided.

Lighted Models

Connect light leads to lugs provided.

Selecting four or eight note operation

For the front door signal, you may select either four note or eight note operation. Selector switch is shown in Figures 1, 2, and 3.

FINAL ADJUSTMENTS

VOLUME ADJUSTMENT

Make any necessary adjustments using the volume control.

TUBE INSTALLATION (long tube models).

1. Refer to Figure 4. Hang tubes onto hanger bracket hooks so that the longest tube is at the left and the shortest at the right. Adjust tube supports on hanger brackets so plungers strike tubes to produce proper tone quality.
2. Adjust volume control as desired.
3. **IMPORTANT:** If the volume control has been set to the maximum level, the chime may double strike one or more notes. If this should occur, turn the volume control down to a lower level.

If chime plungers should ever get "sluggish" in their movement, clean the plungers with a non-flammable cleaning fluid and wipe dry.

CAUTION: NEVER OIL CHIME PLUNGERS.

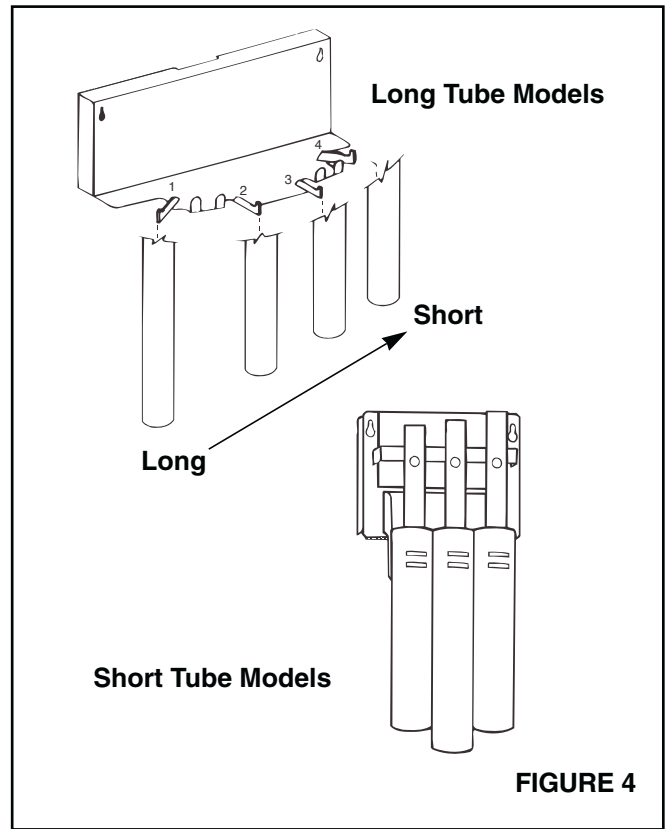

FIGURE 4

NuTone®

One Year Limited Warranty

WARRANTY OWNER: NuTone warrants to the original consumer purchaser of its products that such products will be free from defects in materials or workmanship for a period of one (1) year from the date of original purchase. **THERE ARE NO OTHER WARRANTIES, EXPRESS OR IMPLIED, INCLUDING, BUT NOT LIMITED TO, IMPLIED WARRANTIES OF MERCHANTABILITY OR FITNESS FOR A PARTICULAR PURPOSE.**

During this one year period, NuTone will, at its option, repair or replace, without charge, any product or part which is found to be defective under normal use and service. THIS WARRANTY DOES NOT EXTEND TO FLUORESCENT LAMP STARTERS OR TUBES, FILTERS, DUCT, ROOF CAPS, WALL CAPS AND OTHER ACCESSORIES FOR DUCTING. This warranty does not cover (a) normal maintenance and service or (b) any products or parts which have been subject to misuse, negligence, accident, improper maintenance or repair (other than by NuTone), faulty installation or installation contrary to recommended installation instructions.

The duration of any implied warranty is limited to the one year period as specified for the express warranty. Some states do not allow limitation on how long an implied warranty lasts, so the above limitation may not apply to you.

NUTONE'S OBLIGATION TO REPAIR OR REPLACE, AT NUTONE'S OPTION, SHALL BE THE PURCHASER'S SOLE AND EXCLUSIVE REMEDY UNDER THIS WARRANTY. NUTONE SHALL NOT BE LIABLE FOR INCIDENTAL, CONSEQUENTIAL OR SPECIAL DAMAGES ARISING OUT OF OR IN CONNECTION WITH PRODUCT USE OR PERFORMANCE. Some states do not allow the exclusion or limitation of incidental or consequential damages, so the above limitation or exclusion may not apply to you. This warranty gives you specific legal rights, and you may also have other rights, which vary from state to state. This warranty supersedes all prior warranties.

WARRANTY SERVICE: To qualify for warranty service, you must (a) notify NuTone at the address stated below or telephone 1/800-543-8687, (b) give the model number and part identification and (c) describe the nature of any defect in the product or part. At the time of requesting warranty service, you must present evidence of the original purchase date.

Date of Installation

Builder or Installer

Model No. and Product Description

IF YOU NEED ASSISTANCE OR SERVICE:

For the location of your nearest NuTone Independent Authorized Service Center:

Residents of the contiguous United States Dial Free 1-800-543-8687

Please be prepared to provide:

Product model number • Date and Proof of purchase • The nature of the difficulty

Residents of Alaska or Hawaii should write to: NuTone Inc. Attn: Department of National Field Service, 4820 Red Bank Road, Cincinnati Ohio 45227-1599.

Residents of Canada should write to: Broan-NuTone Canada, 1140 Tristar Drive, Mississauga, Ontario, Canada L5T 1H9.

Rev. 03/2001