

**FNCCAB and FILXXFNC  
HIGH EFFICIENCY FAN COIL FILTRATION  
SIZES 14, 17, 21 and 24**



## Product Data



A10040

**FNCCAB Filter Cabinet**

## FILTER CABINET (FNCCAB)

### MODEL NUMBER NOMENCLATURE

1	2	3	4	5	6	7	8	9	10	11	12
F	N	C	C	A	B	B	B	0	0	1	4
<b>Product Type</b> Fan Coil Filter Cabinet						<b>Brand</b> Bryant			<b>Size</b> 14 17 21 24		
<b>Factory Assigned</b> 00 - Not used											

### Model FNCCAB

The FNCCAB Mechanical Air Cleaner cleans the air of dust, pollen, and smoke which helps keep homes cleaner and fresher longer.

### FEATURES/BENEFITS

**EASY FILTER ACCESS** — Using the FNCCAB air cleaner allows homeowners easy filter access on their fan coil system. They will no longer have to go inside the fan coil to access or change the filter.

**IMPROVED INDOOR FILFNC AIR QUALITY (IAQ)** — The FILFNC filter, included with the FNCCAB media cabinet, provides MERV 8 air cleaning efficiency for improved IAQ. For enhanced filtration, a MERV 11 option is available.

**TROUBLE-FREE INSTALLATION** — No electricity is required.

**NEARLY MAINTENANCE FREE OPERATION** — The only maintenance required is replacing the media filter cartridge when needed – before each heating or cooling season or at least twice a year, depending on conditions.

### DIMENSIONS

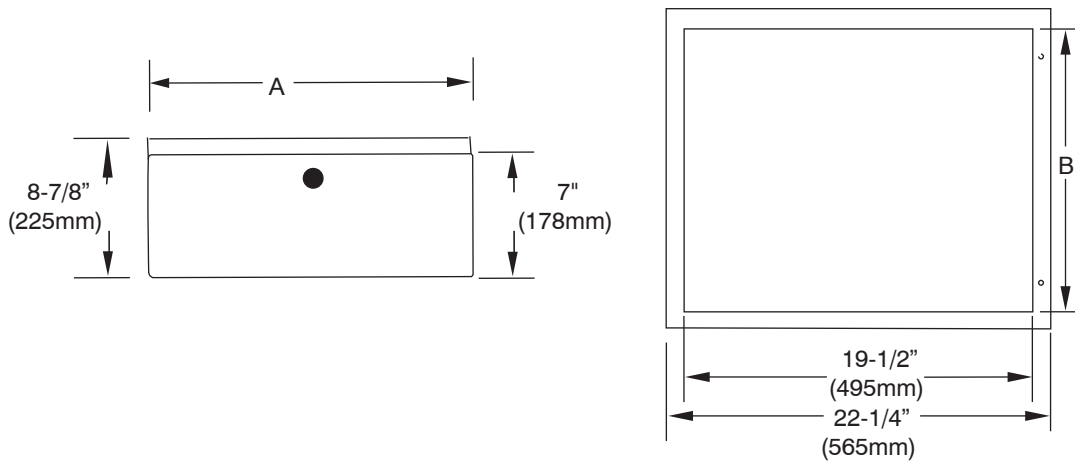

A09651

MODELS	FNCCABBB0014	FNCCABBB0017	FNCCABBB0021	FNCCABBB0024
Airflow (CFM) Range	600- 900	600- 1350	600- 2000	600- 2200
A	14- 5/16" (364mm)	17- 5/8" (448mm)	21- 1/8" (537mm)	24- 5/8" (625mm)
B	11" (279mm)	14- 11/32" (364mm)	17- 7/8" (454mm)	21- 11/32" (542mm)

**FAN COIL FILTER (FILXXFNC)  
MODEL NUMBER NOMENCLATURE**

	<b>1</b>	<b>2</b>	<b>3</b>	<b>4</b>	<b>5</b>	<b>6</b>	<b>7</b>	<b>8</b>	<b>9</b>	<b>10</b>	<b>11</b>	<b>12</b>
	<b>F</b>	<b>I</b>	<b>L</b>	<b>X</b>	<b>X</b>	<b>F</b>	<b>N</b>	<b>C</b>	<b>0</b>	<b>0</b>	<b>1</b>	<b>4</b>
<b>Product Type</b> Media Filter											<b>Size</b> 14 17 21 24	
<b>Brand</b> Non-Branded												
<b>Type</b> FNC = Fan Coil Application Filter											<b>MERV</b> 0 - MERV 8 1 - MERV 11	
											<b>Factory Assigned</b> 0 = Not Used	

**Model FILXXFNC**

This filter’s Minimum Efficiency Reporting Value (MERV) is specified by ASHRAE Standard 52.2. It is based on lab tests to determine the filter’s ability to trap particles. MERVs for residential filters will typically be in the range of MERV 1-13. The higher the value, the more efficient the filter. MERV 8 filters have a minimum of 70% particle collection efficiency in the 3-10 micron particle size range. (Human hair is approximately 50-100 microns in diameter.) All four sizes of filters reach a MERV 8. For enhanced filtration, a MERV 11 option is available.

unique low-pressure drop design — providing some of the largest dust-holding capacities available in efficient residential air cleaners today.

The exceptionally large surface area traps dust, pollen, molds, tobacco smoke, grease, soot, bacteria, and animal dander to provide cleaner, fresher air that is free of airborne pollutants and irritants regardless of the season.

**EXCEPTIONAL SYSTEM PERFORMANCE** — For optimum system performance use the FNCCAB & Bryant FILXXFNC high efficiency media filters designed especially for Bryant furnaces.

**FEATURES/BENEFITS**

**LARGE DUST HOLDING CAPACITY** — These filters accommodate between 13 and 25 sq. ft. of filter media into a

**REPLACEMENT FILTERS**

REPLACEMENT FILTERS ORDER NUMBER				
<b>MERV 8</b>	FILXXFNC0014	FILXXFNC0017	FILXXFNC0021	FILXXFNC0024
<b>MERV 11</b>	FILXXFNC0114	FILXXFNC0117	FILXXFNC0121	FILXXFNC0124
<b>Quantity per Carton</b>	2	2	2	2

**DIMENSIONS**

PRODUCT NUMBER	MEDIA AREA (GROSS)	DIMENSIONS In. (mm) TOLERANCE +/-0.125” (3mm)
FILXXFNC0014 / FILXXFNC0114	≥13.05 sq. ft (1.2 sq. m)	19.8125 x 12.175 x 4.3125 (503.2 x 309.2 x 109.5)
FILXXFNC0017 / FILXXFNC0117	≥17.8 sq. ft. (1.7 sq. m)	19.8125 x 15.625 x 4.3125 (503.2 x 396.8 x 109.5)
FILXXFNC0021 / FILXXFNC0121	≥20.17 sq. ft. (1.9 sq.m)	19.8125 x 19.125 x 4.3125 (503.2 x 485.7 x 109.5)
FILXXFNC0024 / FILXXFNC0124	≥24.9 sq. ft. (2.3 sq. m)	19.8125 x 22.625 x 4.3125 (503.2 x 574.6 x 109.5)

## FAN COIL FILTER (FILXXFNC) - cont.

### PHYSICAL DATA

SIZE	014 / 114	017 / 117	021 / 121	024 / 124
Rated Airflow	900 / 900	1350 / 1350	2000 / 1800	2200 / 2000
MERV	8 / 11	8 / 11	8 / 11	8 / 11
Typical Static Pressure Drop (in. wc.) (Clean@rated airflow)	.20 / .20	.23 / .24	.28 / .30	.25 / .25
Filter Media	Polyolefin / Polypropylene polyethylene			
Shipping Weight (2 pack)	5- lb. (2.3 kg.)	6- lb. (2.7 kg.)	6.5- lb (2.9 kg.)	7- lb (3.2 kg.)

PLEATED MEDIA FILTER	MERV 8 EFFICIENCY <sup>1</sup>	MERV 11 EFFICIENCY <sup>1</sup>
14- in. FILXXFNC0014 / FILXXFNC0114	E1: 24.4%	E1: 43.0%
	E2: 55.4%	E2: 71.6%
	E3: 70.9%	E3: 89.6%
17- in. FILXXFNC0017 / FILXXFNC117	E1: 24.4%	E1: 43.0%
	E2: 55.4%	E2: 71.6%
	E3: 70.9%	E3: 89.6%
21- in. FILXXFNC0021 / FILXXFNC0121	E1: 24.4%	E1: 43.0%
	E2: 55.4%	E2: 71.6%
	E3: 70.9%	E3: 89.6%
24- in. FILXXFNC0024 / FILXXFNC0124	E1: 24.4%	E1: 43.0%
	E2: 55.4%	E2: 71.6%
	E3: 70.9%	E3: 89.6%

**NOTES:**

1. Minimum Efficiency Reporting Value (MERV) per ASHRAE 52.2 (Exceeds proposed ASHRAE 62.2p requirement for manufacturers to provide a filter with a MERV rating of at least 6.

E1: MINIMUM Average Efficiency for particles sized between 0.3 and 1 micron.

E2: MINIMUM Average Efficiency for particles sized between 1 and 3 microns.

E3: MINIMUM Average Efficiency for particles sized between 3 and 10 microns.

### PRESSURE DROP AT VARIOUS AIRFLOWS (CLEAN)

TYPICAL PRESSURE DROP					
AIR FLOW (CFM) RANGE	FACTORY SUPPLIED FILTER	FILXXFNC0014 / FILXXFNC0114	FILXXFNC0017 / FILXXFNC0117	FILXXFNC0021 / FILXXFNC0121	FILXXFNC0024 / FILXXFNC0124
		RESISTANCE (in wc)			
600	.044	.120 / .120	.060 / .060	.040 / .050	.015 / .030
800	.075	.150 / .150	.090 / .095	.060 / .080	.030 / .050
1000	.072	.250 / .250	.125 / .140	.070 / .110	.040 / .075
1200	.100	—	.180 / .190	.090 / .150	.060 / .100
1400	.092	—	.250 / .250	.140 / .190	.090 / .130
1600	.120	—	—	.187 / .250	.125 / .160
1800	.152	—	—	.230 / .300	.150 / .200
2000	.187	—	—	.280 / —	.190 / .250
2200	—	—	—	—	.250 / —

# TYPICAL INSTALLATIONS

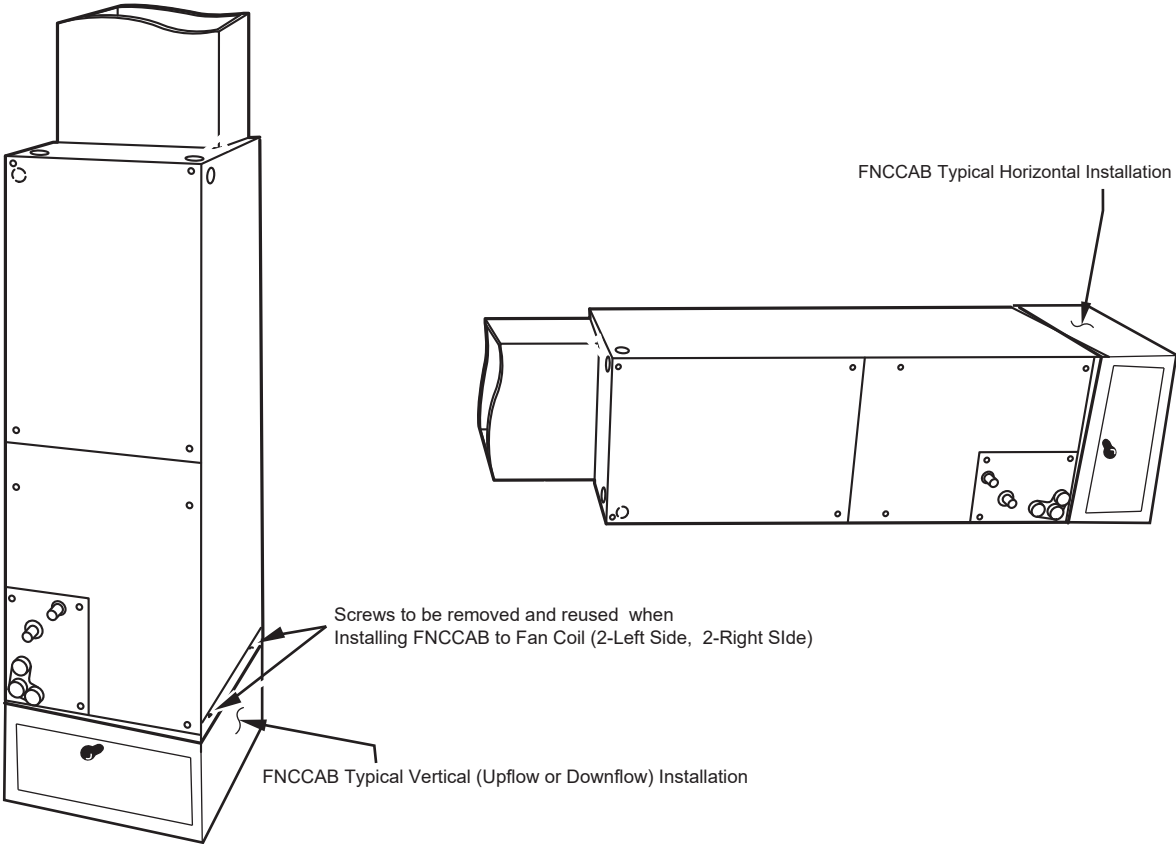

C04029

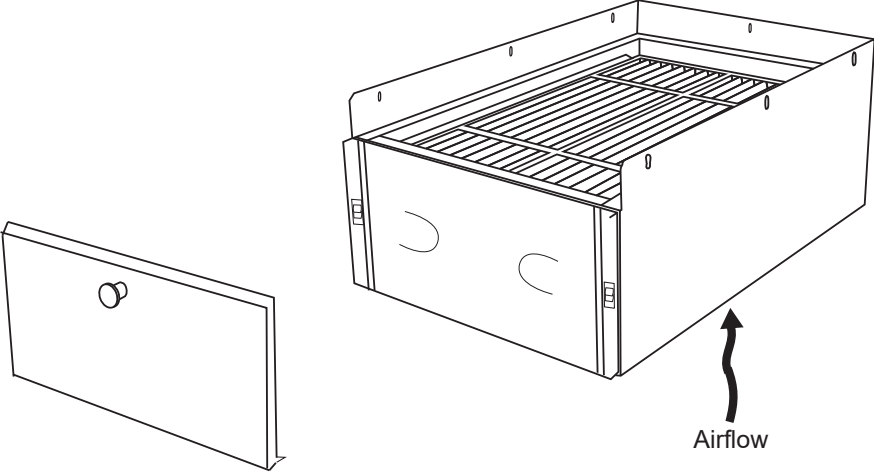

Install FILFNC Media Filter Cartridge in the FNCCAB Media Filter Cabinet.

C04033A

