

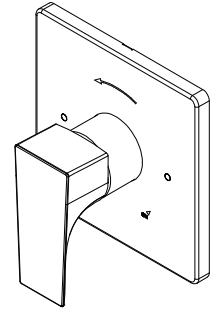

SYMMONS Verity™

Location:



4990TRM
Shower Valve Trim
Specification Submittal

Model Numbers

- 4990TRM**
Shower Valve Trim
- Valve Options:**
-262 or 261 Series Temptrol® Shower Valve with TRM modifier
-162 or 161 Series Temptrol Shower Valve requires TC modifier

Feature Highlights

- Verity Shower Valve Trim.
- Requires Temptrol® Pressure-Balancing Shower Valve.
- Metal lever handle.
- Components shall be metal and nonmetal construction, plated in standard Polished Chrome finish.

Compliance

- ASME® A112.18.1/CSA® B125.1
- Lever handle meets ADA requirements for operation



Options/Modifications

- TC** Test Cap Trim (includes TA-10™ & T-12A) used with 161/162 Series Temptrol Shower Valve
- L7** Less handle
- MB** Matte Black finish
- STN** Satin Nickel finish

Warranty

Limited Lifetime - for residential installations.
10 Years - for commercial/industrial installations.
Refer to www.symmons.com/warranty for complete warranty information.

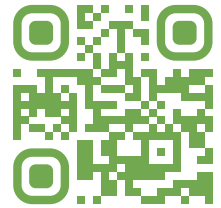

SKU Builder

Series	Finish	Modifier	Trim (required)	Test Cap	Final SKU
4990	MB	L7	TRM	TC	4990MBL7TRMTC

Architectural/Engineering Specification

Symmons _____ Includes Verity Shower Valve Trim for Temptrol® Pressure-Balancing Shower Valve. Features metal lever handle. Components shall be metal and nonmetal construction, and plated in standard Polished Chrome finish. 10-Year Commercial Warranty. ASME A112.18.1/CSA B125.1 compliant. Lever handle meets ADA requirements for operation. Available options include: TC = Test Cap Trim, L7 = Less handle, MB = Matte Black finish, STN = Satin Nickel finish.

Dimensions

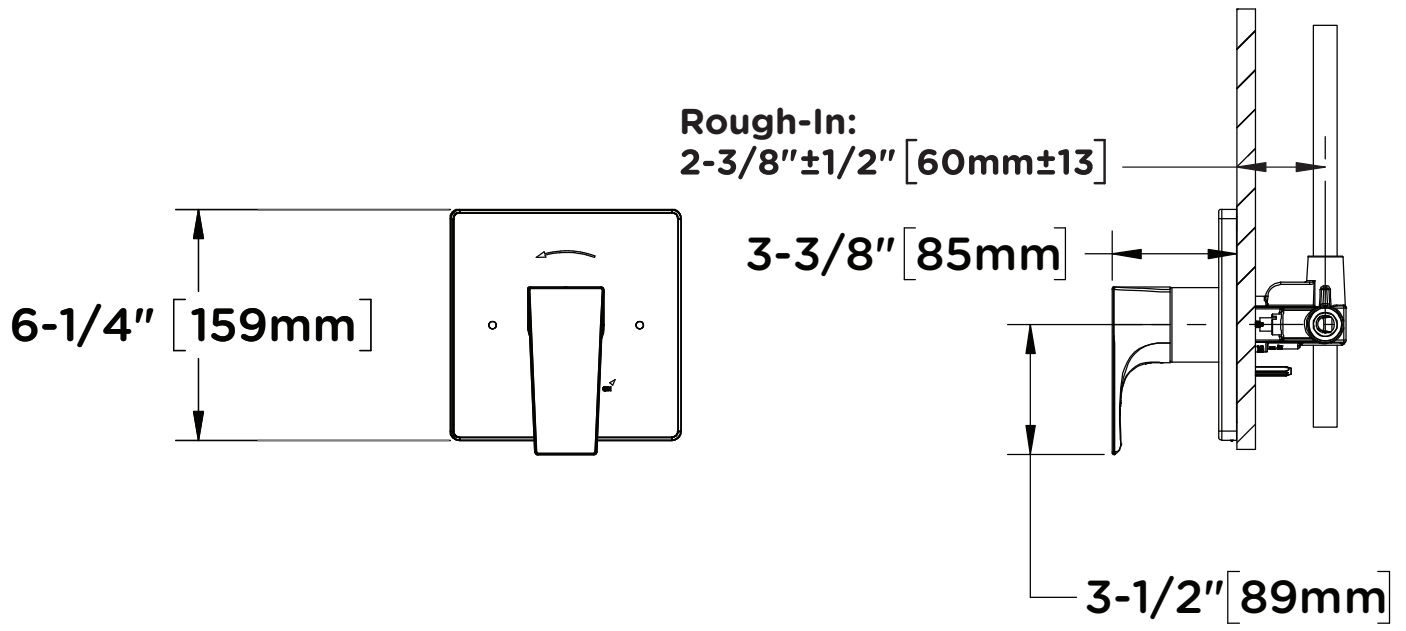

Notes:

- 1) Valve body and piping not included and shown as reference only.
- 2) Plaster shield (p/n T-176) for drywall, plaster, or other type walls $1/2''$ or greater.
- 3) All dimensions measured from nominal rough-in.
- 4) Dimensions subject to change without notice.