



Product Data

WeatherMaster® Single Packaged Rooftop

3 to 5 Nominal Tons

ecoblue™  technology



48/50GC**04, 05, 06

48GC: Single-Package Gas Heating/Electric Cooling Rooftop Units
50GC: Electric Cooling Rooftop Units with Optional Electric Heat
with Puron® Refrigerant (R-410A)

The New Carrier WeatherMaster® rooftop units (RTU) with EcoBlue™ Technology were designed by customers for customers and integrate new technology to provide value added benefits never seen in this type of equipment before.

New major design features include:

- Patented, industry’s first efficient indoor fan system using Vane Axial Fan technology — with electronically commutated variable speed motor.
- Reliable 2-stage scroll compressor on all sizes.
- Upgraded unit control board with intuitive indoor fan adjustment.
- Reliable copper tube/aluminum fin condenser coil with 5/16 in. tubing to help reduce refrigerant charge versus prior designs.
- New outdoor fan system with rugged, lightweight, high impact composite fan blade

WeatherMaster® 48/50GC units up to 5 tons are specifically designed to fit on Carrier roof curbs that were installed back to 1989, which makes replacement easy and eliminates the need for curb adapters or changing utility connections.

Two-stage cooling capacity control delivers efficiencies of up to 17.4 SEER and 16.5 SEER2. All models are capable of either vertical or horizontal airflow.

The Carrier rooftop unit (RTU) was designed by customers for customers. With “no-strip” screw collars, handled access panels, and more, the unit is easy to install, easy to maintain, and easy to use. Your new 3 to 5 ton WeatherMaster Carrier rooftop unit (RTU) provides optimum comfort and control from a packaged rooftop.

Value-added features include:

- optional Humidi-MiZer® adaptive dehumidification system for improved part load humidity performance
- Puron® refrigerant (R-410A)
- single point gas and electrical connections
- optional fully integrated SystemVu™ controls
- RTU Open controller for BACnet™1, LonWorks®1, Modbus®1 and Johnson Controls®1 N2
- optional fully insulated cabinet with optional foil faced insulation
- TXV refrigerant metering system
- Scroll compressors with internal line-break overload protection
- Units come with an easy access tool-less filter door. Filter track tilts out for filter removal and replacement. All filters are the same size in each unit.

Installation ease

All WeatherMaster units are field-convertible to horizontal airflow, which

1. Third-party trademarks and logos are the property of their respective owners.

makes it easy to adjust to unexpected jobsite complications. Lighter units make for easy replacement. Simple, fast plug-in connections to the standard integrated unit control board (UCB). Clearly labeled connections points to reduce installation time. Also, a large control box provides room to work and room to mount Carrier accessory controls.

Easy to maintain

With the new EcoBlue Vane Axial fan system and direct drive ECM motor, there is no longer a need to adjust belts or pulleys as in past designs. This frees up maintenance and installation time.

Easy access handles by Carrier provide quick and easy access to all normally serviced components. Our “no-strip” screw system has superior holding power and guides screws into position while preventing the screw from stripping the unit’s metal.

Sloped, corrosion resistant composite drain pan sheds water and will not rust.

Easy to use

The newly re-designed Unit Control Board by Carrier puts all connections and troubleshooting points in one convenient place. Most low voltage connections are made to the same board and make it easy to access. Setting up the fan is simple using an intuitive switch and rotary dial arrangement. Carrier rooftops have high and low pressure switches, a filter drier, and 2 in. filters standard.

Table of contents

	Page
Features/Benefits	2
Model Number Nomenclature	4
Capacity Ratings	6
Physical Data	10
Options and Accessories	18
Base Unit Dimensions	23
Accessory Dimensions	29
Performance Data	30
Fan Data	44
Electrical Data	93
Typical Wiring Diagrams	119
Sequence of Operation	135
Application Data	138
Guide Specifications — 48GC	140
Guide Specifications — 50GC	152

EcoBlue Technology

Direct drive EcoBlue™ Technology indoor fan system uses Vane Axial fan design and electronically commutated motors.

This new Vane Axial design, compared to past belt drive systems, has 75% fewer moving parts, uses up to 40% less energy, and has no fan belts, blower bearings, or shaft.

Streamlined control and integration

Carrier controllers make connecting WeatherMaster® rooftops into existing building automation systems easy. The units are compatible with conventional

thermostat controls, SystemVu™ controls and Carrier RTU Open multi-protocol controller.

Operating efficiency and flexibility

The 48/50GC rooftops exceed ASHRAE (American Society of Heating, Refrigerating, and Air-Conditioning Engineers) 90.1-2016, IECC®¹ (International Energy Conservation Code) IECC-2018 minimum efficiency requirements.

Field convertible airflow

All WeatherMaster 3 to 5 ton units are field-convertible to horizontal airflow, which makes it easy to adjust to unexpected jobsite complications.

Comfort control

Carrier's patented Humidi-MiZer® adaptive dehumidification system is an all-inclusive factory-installed option on gas heating/electric cooling and electric cooling/electric heat models. This system provides reliable, flexible operation to meet indoor part load sensible and latent requirements.

1. Third-party trademarks and logos are the property of their respective owners.



48GC Model Number Nomenclature

Position:	1	2	3	4	5	6	7	8	9	10	11	12	13	14	15	16	17	18
Example:	4	8	G	C	D	L	0	4	A	2	A	5	-	0	A	0	A	0

Unit Heat Type
48 = Gas Heat Packaged Rooftop

Model Series — WeatherMaster®
GC = 17.4 SEER and 16.5 SEER2 High Eff.

Heat Options
D = Low Gas Heat
E = Medium Gas Heat
F = High Gas Heat
L = Low NOx — Low Gas Heat ^a
S = Low Heat with Stainless Steel Exchanger
R = Medium Heat with Stainless Steel Exchanger
T = High Heat with Stainless Steel Exchanger

Refrig. Systems Options
H = Two-Stage Cooling with Low Ambient Control (1-phase only) ^{b,c}
J = Two-Stage Cooling ^b
K = Two-Stage Cooling with Humidi-MiZer system (includes Low Ambient control) ^b
L = Two-Stage Cooling with Low Ambient control ^b
T = Two-Stage Cooling (1-phase only) ^{b,c}

Cooling Tons
04 = 3 ton
05 = 4 ton
06 = 5 ton

Sensor Options
A = None
B = RA (Return Air) Smoke Detector
C = SA (Supply Air) Smoke Detector
D = RA + SA Smoke Detector
E = CO₂
F = RA Smoke Detector and CO₂
G = SA Smoke Detector and CO₂
H = RA + SA Smoke Detector and CO₂
J = Condensate Overflow Switch
K = Condensate Overflow Switch and RA Smoke Detector
L = Condensate Overflow Switch and RA and SA Smoke Detectors
M = Condensate Overflow Switch and SA Smoke Detector

Indoor Fan Options
1 = Direct Drive EcoBlue™ — Standard Static
2 = Direct Drive EcoBlue — Medium Static
3 = Direct Drive EcoBlue — High Static

Coil Options — Round Tube/Plate Fin Condenser Coil (Outdoor - Indoor — Hail Guard)
A = Al/Cu - Al/Cu
B = Precoat Al/Cu - Al/Cu
C = E-coat Al/Cu - Al/Cu
D = E-coat Al/Cu - E-coat Al/Cu
E = Cu/Cu - Al/Cu
F = Cu/Cu - Cu/Cu
M = Al/Cu - Al/Cu — Louvered Hail Guard
N = Precoat Al/Cu - Al/Cu — Louvered Hail Guard
P = E-coat Al/Cu - Al/Cu — Louvered Hail Guard
Q = E-coat Al/Cu - E-coat Al/Cu — Louvered Hail Guard
R = Cu/Cu - Al/Cu — Louvered Hail Guard
S = Cu/Cu - Cu/Cu — Louvered Hail Guard

Factory Assigned
0 = Standard
1 = LTL

Electrical Options
A = None
B = HACR Breaker
C = Non-Fused Disconnect (NFD)
D = Thru-the-Base (TTB) Connections
F = Non-Fused Disconnect and TTB Conn.
N = Phase Monitor Protection
P = Phase Monitor Protection and HACR
Q = Phase Monitor Protection and NFD
R = Phase Monitor Protection and TTB Conn.
S = Phase Monitor Protection, HACR Breaker, and TTB Conn.
T = Phase Monitor Protection, NFD, and TTB Conn.

Service Options
0 = None
1 = Unpowered Convenience Outlet (CO)
2 = Powered Convenience Outlet
3 = Hinged Access Panels
4 = Hinged Access Panels and Unpowered CO
5 = Hinged Panels and Powered CO
6 = MERV-13 High Efficiency Filters
C = Foil Faced Insulation

Intake / Exhaust Options
A = None
B = Temperature Economizer with Barometric Relief
F = Enthalpy Economizer with Barometric Relief
U = Temperature Ultra Low Leak Economizer with Barometric Relief
W = Enthalpy Ultra Low Leak Economizer with Barometric Relief

Base Unit Controls
0 = Electromechanical Controls (allows for use of field-installed economizers)
2 = RTU Open Multi-Protocol Controller
3 = SystemVu™ Controls with Display
8 = Electromechanical Controls with POL224 EconomizerONE (with Fault Detection and Diagnostic)

Design Revision
- = Factory Design Revision

Voltage
1 = 575-3-60
3 = 208/230-1-60 ^o
5 = 208/230-3-60
6 = 460-3-60

NOTE(S):
a. Low NOx models include Stainless Steel HX.
b. Units meet Department of Energy 2023 SEER2 requirements.
c. The following are not available as a factory-installed options for models with this voltage code: Humidi-MiZer System, Coated Coils or Cu Fin Coils, Louvered Hail Guards, Economizer, and Powered 115 Volt Convenience Outlet.

Model number nomenclature (cont)



50GC Model Number Nomenclature

Position:	1	2	3	4	5	6	7	8	9	10	11	12	13	14	15	16	17	18
Example:	5	0	G	C	-	L	0	4	A	1	A	5	-	0	A	0	A	0

Unit Heat Type
50 = Electric Heat
Packaged Rooftop

Model Series — WeatherMaster®
GC = 17.4 SEER and 16.5 SEER2 High Eff.

Heat Options
- = No Heat
A = Low Electric Heat
B = Medium Electric Heat
C = High Electric Heat

Refrig. Systems Options
H = Two-Stage Cooling with Low Ambient Control (1-phase only)^{1,2}
J = Two Stage Cooling Models¹
K = Two Stage Cooling Models with Humidi-MiZer® system (includes Low Ambient control)¹
L = Two Stage Cooling Models with Low Ambient Control¹
T = Two-Stage Cooling (1-phase only)^{1,2}

Cooling Tons
04 = 3 ton
05 = 4 ton
06 = 5 ton

Sensor Options
A = None
B = RA (Return Air) Smoke Detector
C = SA (Supply Air) Smoke Detector
D = RA + SA Smoke Detector
E = CO₂
F = RA Smoke Detector and CO₂
G = SA Smoke Detector and CO₂
H = RA + SA Smoke Detector and CO₂
J = Condensate Overflow Switch (electromechanical controls only)
K = Condensate Overflow Switch and RA Smoke Detectors
L = Condensate Overflow Switch and RA and SA Smoke Detectors
M = Condensate Overflow Switch and SA Smoke Detectors

Indoor Fan Options
1 = Direct Drive – EcoBlue – Standard Static
2 = Direct Drive – EcoBlue – Medium Static
3 = Direct Drive – EcoBlue – High Static

Coil Options (RTPF) (Outdoor - Indoor — Hail Guard)
A = Al/Cu - Al/Cu
B = Precoat Al/Cu - Al/Cu
C = E-coat Al/Cu - Al/Cu
D = E-coat Al/Cu - E-coat Al/Cu
E = Cu/Cu - Al/Cu
F = Cu/Cu - Cu/Cu
M = Al/Cu - Al/Cu — Louvered Hail Guard
N = Precoat Al/Cu - Al/Cu — Louvered Hail Guard
P = E-coat Al/Cu - Al/Cu — Louvered Hail Guard
Q = E-coat Al/Cu - E-coat Al/Cu — Louvered Hail Guard
R = Cu/Cu - Al/Cu — Louvered Hail Guard
S = Cu/Cu - Cu/Cu — Louvered Hail Guard

Factory Assigned
0 = Standard
1 = LTL

Electrical Options
A = None
B = HACR Breaker
C = Non-Fused Disconnect (NFD)
D = Thru-the-Base (TTB) Connections
E = HACR and Thru-the-Base Connections
F = Non-Fused Disconnect and TTB Conn.
N = Phase Monitor Protection
P = Phase Monitor Protection and HACR Breaker
Q = Phase Monitor Protection and NFD
R = Phase Monitor Protection and TTB Conn.
S = Phase Monitor Protection, HACR Breaker, and TTB Conn.
T = Phase Monitor Protection, NFD, and TTB Conn.

Service Options
0 = None
1 = Unpowered Convenience Outlet (CO)
2 = Powered Convenience Outlet
3 = Hinged Panels
4 = Hinged Panels and Unpowered CO
5 = Hinged Panels and Powered CO
6 = MERV-13 High Efficiency Filters
C = Foil-Faced Insulation

Intake / Exhaust Options
A = None
B = Temperature Economizer with Barometric Relief
F = Enthalpy Economizer with Barometric Relief
K = Two-Position Damper
U = Temperature Ultra Low Leak Economizer with Barometric Relief
W = Enthalpy Ultra Low Leak Economizer with Barometric Relief

Base Unit Controls
0 = Electromechanical Controls (allows for use of field-installed economizers)
2 = RTU Open Multi-Protocol Controller
3 = SystemVu™ Controller
8 = Electromechanical Controls with POL224 EconomizerONE (with Fault Detection and Diagnostic)

Design Revision
- = Factory Design Revision

Voltage
1 = 575-3-60
3 = 208/230-1-60²
5 = 208/230-3-60
6 = 460-3-60

¹ Units meet Department of Energy 2023 SEER2 requirements; available.

² The following are not available as a factory-installed options for models with this voltage code: Humidi-MiZer® System, Coated Coils or Cu Fin Coils, Louvered Hail Guards, Economizer or Two-Position Damper, and Powered 115 Volt Convenience Outlet.

48GC*T 1-Phase AHRI Rating^{a,b,c,d}

48GC UNIT	VOLTAGE	COOLING STAGES	NOMINAL CAPACITY (tons)	NET COOLING CAPACITY 2 (MBtuh)	TOTAL POWER (kW)	SEER2	EER2
48GC*T04	3	2	3	35.0	2.9	16.0	12.0
48GC*T05	3	2	4	46.5	3.9	16.0	12.0
48GC*T06	3	2	5	59.0	4.9	16.5	12.0

NOTE(S):

- Rated in accordance with AHRI Standards 210/240.
- Rating are based on:
Cooling Standard: 80°F (27°C) db, 67°F (19°C) wb indoor air temperature and 95°F (35°C) db outdoor air temperature.
- Units comply with ASHRAE 90.1-2016 (American Society of Heating, Refrigerating, and Air-Conditioning Engineers) and DOE-2023 (Department of Energy) Energy Standard for minimum SEER2 and EER2 requirements.
- 48GC units comply with US Energy Policy Act (2005). To evaluate code compliance requirements, refer to state and local codes.

48GC 3-Phase AHRI Rating^{a,b,c,d}

48GC UNIT	VOLTAGE	COOLING STAGES	NOMINAL CAPACITY (TONS)	NET COOLING CAPACITY (MBtuh)	TOTAL POWER (kW)	SEER	EER
48GC*J04	1, 5, 6	2	3	36.0	2.8	17.4	12.8
48GC*J05	1, 5, 6	2	4	48.0	3.8	17.4	12.8
48GC*J06	1, 5, 6	2	5	59.5	4.6	17.4	12.8

48GC UNIT	NET COOLING CAPACITY 2 (MBtuh)	TOTAL POWER 2 (kW)	SEER 2	EER2
48GC*J04	35.0	2.9	16.0	12.0
48GC*J05	46.5	3.9	16.0	12.0
48GC*J06	59.0	4.9	16.5	12.0

NOTE(S):

- Rated in accordance with AHRI Standards 210/240.
- Rating are based on:
Cooling Standard: 80°F (27°C) db, 67°F (19°C) wb indoor air temperature and 95°F (35°C) db outdoor air temperature.
- Units comply with ASHRAE 90.1-2016 (American Society of Heating, Refrigerating, and Air-Conditioning Engineers) requirements, as well as DOE-2018 (Department of Energy) Energy Standard for minimum SEER and EER requirements or DOE-2023 Energy Standards for minimum SEER2 and EER2 requirements.
- 48GC units comply with US Energy Policy Act (2005). To evaluate code compliance requirements, refer to state and local codes.

LEGEND

- AHRI — Air-Conditioning, Heating and Refrigeration Institute
- EER — Energy Efficiency Ratio
- IEER — Integrated Energy Efficiency Ratio
- MBtuh — Btuh in thousands
- SEER — Seasonal Energy Efficiency Ratio



Capacity ratings (cont)



50GC 1-Phase AHRI Ratings^{a,b,c,d}

50GC UNIT	VOLTAGE	COOLING STAGES	NOMINAL CAPACITY (TONS)	NET COOLING CAPACITY 2 (MBtuh)	TOTAL POWER (kW)	SEER2	EER2
50GC*T04	3	2	3	35.0	2.9	16.0	12.0
50GC*T05	3	2	4	46.5	3.9	16.0	12.0
50GC*T06	3	2	5	59.0	4.9	16.5	12.0

NOTE(S):

- Rated in accordance with AHRI Standards 210/240.
- Rating are based on:
Cooling Standard: 80°F (27°C) db, 67°F (19°C) wb indoor air temperature and 95°F (35°C) db outdoor air temperature.
- Units comply with ASHRAE 90.1-2016 (American Society of Heating, Refrigerating, and Air-Conditioning Engineers) and DOE-2023 (Department of Energy) Energy Standard for minimum SEER2 and EER2 requirements.
- 50GC units comply with US Energy Policy Act (2005). To evaluate code compliance requirements, refer to state and local codes.

50GC 3-Phase AHRI Rating^{a,b,c,d}

50GC UNIT	VOLTAGE	COOLING STAGES	NOMINAL CAPACITY (TONS)	NET COOLING CAPACITY (MBtuh)	TOTAL POWER (kW)	SEER	EER
50GC*J04	1, 5, 6	2	3	36.0	2.8	17.4	12.8
50GC*J05	1, 5, 6	2	4	46.5	3.8	17.4	12.8
50GC*J06	1, 5, 6	2	5	59.0	4.6	17.4	12.8

50GC UNIT	NET COOLING CAPACITY 2 (MBtuh)	TOTAL POWER 2 (kW)	SEER2	EER2
50GC*J04	35.0	2.9	16.0	12.0
50GC*J05	46.5	3.9	16.0	12.0
50GC*J06	59.0	4.9	16.0	12.0

NOTE(S):

- Rated in accordance with AHRI Standards 210/240.
- Rating are based on:
Cooling Standard: 80°F (27°C) db, 67°F (19°C) wb indoor air temperature and 95°F (35°C) db outdoor air temperature.
- Units comply with ASHRAE 90.1-2016 (American Society of Heating, Refrigerating, and Air-Conditioning Engineers) requirements, as well as DOE-2018 (Department of Energy) Energy Standard for minimum SEER and EER requirements or DOE-2023 Energy Standard for minimum SEER2 and EER2 requirements..
- 50GC units comply with US Energy Policy Act (2005). To evaluate code compliance requirements, refer to state and local codes.

LEGEND

- AHRI** — Air-Conditioning, Heating and Refrigeration Institute
EER — Energy Efficiency Ratio
IEER — Integrated Energy Efficiency Ratio
MBtuh — Btuh in thousands
SEER — Seasonal Energy Efficiency Ratio

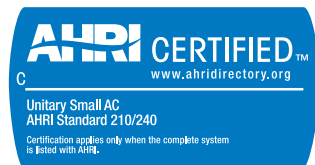

Capacity ratings (cont)



Sound Ratings^{a,b,c}

48/50GC UNIT	COOLING STAGES	OUTDOOR SOUND (dB) AT 60 Hz								
		A-Weighted	63	125	250	500	1000	2000	4000	8000
**04	2	79	85.6	84.7	80.5	76.0	72.4	68.0	62.8	59.3
**05	2	79	85.6	84.7	80.5	76.0	72.4	68.0	62.8	59.3
**06	2	79	85.6	84.7	80.5	76.0	72.4	68.0	62.8	59.3

NOTE(S):

- Outdoor sound data is measured in accordance with AHRI.
- Measurements are expressed in terms of sound power. Do not compare these values to sound pressure values because sound pressure depends on specific environmental factors which normally do not match individual applications. Sound power values are independent of the environment and therefore more accurate.
- A-weighted sound ratings filter out very high and very low frequencies, to better approximate the response of "average" human ear. A-weighted measurements for Carrier units are taken in accordance with AHRI.

LEGEND

db — Decibel

Minimum - Maximum Airflow Ratings (cfm) — Natural Gas and Propane

UNIT	VOLTAGE	HEAT LEVEL	COOLING				HEATING ^a	
			Minimum Airflow cfm	Minimum 2-Speed Airflow (low speed)	Minimum 2-Speed Airflow (high speed)	Maximum Airflow cfm	Minimum Airflow cfm	Maximum Airflow cfm
48GC**04	1 phase	LOW	900	675	900	1500	890	1950
		MED					800	1520
		HIGH					—	—
	3 phase	LOW	900	675	900	1500	910	2010
		MED					960	1160
		HIGH					—	—
48GC**05	1 phase	LOW	1200	900	1200	2000	890	2440
		MED					1050	2280
		HIGH					1220	2170
	3 phase	LOW	1200	900	1200	2000	910	2010
		MED					1250	2330
		HIGH					1390	2220
48GC**06	1 phase	LOW	1500	1125	1500	2500	890	3250
		MED					1050	2730
		HIGH					1220	2790
	3 phase	LOW	1500	1125	1500	2500	910	2510
		MED					1250	2720
		HIGH					1390	2780

NOTE(S):

- Heating rating values are identical for aluminum heat exchangers and stainless steel heat exchangers.

Minimum - Maximum Airflow Ratings (cfm) — Cooling Units and Accessory Electric Heat

UNIT	COOLING				ELECTRIC HEAT ^a	
	Minimum Airflow cfm	Minimum 2-Speed Airflow (low speed)	Minimum 2-Speed Airflow (high speed)	Maximum Airflow cfm	Minimum Airflow cfm	Maximum Airflow cfm
50GC**04	900	675	900	1500	900	1500
50GC**05	1200	900	1200	2000	1200	2000
50GC**06	1500	1125	1500	2500	1500	2500

NOTE(S):

- Electric heat modules are available as both factory-installed options or field-installed accessories for 50GC units.

Heat Rating — Natural Gas and Propane

48GC UNIT		GAS HEAT	AL/SS HEAT EXCHANGER		TEMPERATURE RISE (°F)	THERMAL EFFICIENCY (%)	AFUE EFFICIENCY (%)
			Input/Output Stage 1 (MBtuh)	Input/Output Stage 2 (MBtuh)			
04	Single Phase	LOW	—/—	65/53	25-55	81	81
		MED	—/—	90/73	45-85	82	81
		HIGH	—/—	—/—	—	—	—
	Three Phase	LOW	50/40	67/54	25-55	81	—
		MED	82/65	110/88	50-85	80	—
		HIGH	—/—	—/—	—	—	—
05	Single Phase	LOW	—/—	65/53	20-55	81	81
		MED	—/—	90/73	30-65	82	81
		HIGH	—/—	130/106	45-80	81	81
	Three Phase	LOW	50/40	67/54	25-55	81	—
		MED	82/65	110/88	35-65	80	—
		HIGH	120/96	150/120	50-80	80	—
06	Single Phase	LOW	—/—	65/53	15-55	81	81
		MED	—/—	90/73	25-65	82	81
		HIGH	—/—	130/106	35-80	81	81
	Three Phase	LOW	50/40	67/54	20-55	81	—
		MED	82/65	110/88	30-65	80	—
		HIGH	120/96	150/120	40-80	80	—

Heat Rating — Low NOx

48GC UNIT		GAS HEAT	AL/SS HEAT EXCHANGER		TEMPERATURE RISE (°F)	THERMAL EFFICIENCY (%)	AFUE EFFICIENCY (%)
			Input/Output Stage 1 (MBtuh)	Input/Output Stage 2 (MBtuh)			
04	Single Phase	LOW	—	60/49	20-50	81	81
	Three Phase	LOW	—	60/49	20-50	81	—
05	Single Phase	LOW	—	60/49	20-50	81	81
	Three Phase	LOW	—	60/49	20-50	81	—
06	Single Phase	LOW	—	60/49	15-50	81	81
	Three Phase	LOW	—	60/49	15-50	81	—

48/50GC 3 Ton Physical Data

48/50GC UNIT	48/50GC*J04	48/50GC*K04	48/50GC*T04
NOMINAL TONS	3	3	3
BASE UNIT OPERATING WT (lb) 48GC/50GC^a	513/468	513/468	513/468
REFRIGERATION SYSTEM			
No. Circuits/No. Compressors/Type	1 / 1 / 2-Stage Scroll	1 / 1 / 2-Stage Scroll	1 / 1 / 2-Stage Scroll
Puron® (R-410A) Charge A/B (lb-oz)	8-4	—	8-4
Humidi-MiZer® Puron (R-410A) Charge A/B (lb-oz)	—	11-3	—
Metering Device	TXV	—	TXV
Humidi-MiZer Metering Device	—	TXV	—
High-Pressure Trip/Reset (psig)	630/505	630/505	630/505
Low-Pressure Trip/Reset (psig)	54/117	27/44	54/117
EVAPORATOR COIL			
Material (Tube/Fin)	Cu/Al	Cu/Al	Cu/Al
Coil Type	3/8 in. RTPF	3/8 in. RTPF	3/8 in. RTPF
Rows/FPI	2/15	2/15	2/15
Total Face Area (ft ²)	5.5	5.5	5.5
Condensate Drain Connection Size	3/4 in.	3/4 in.	3/4 in.
CONDENSER COIL			
Material	Cu/Al	Cu/Al	Cu/Al
Coil Type	5/16 in. RTPF	5/16 in. RTPF	5/16 in. RTPF
Rows/FPI	2/18	2/18	2/18
Total Face Area (ft ²)	11.7	11.7	11.7
HUMIDI-MIZER COIL			
Material	—	Cu/Al	—
Coil Type	—	3/8 in. RTPF	—
Rows/FPI	—	1/17	—
Total Face Area (ft ²)	—	4.1	—
EVAPORATOR FAN AND MOTOR			
Standard Static 1 Phase			
Motor Qty/Drive Type	—	—	1 / Direct
Maximum Cont Bhp	—	—	0.44
Rpm Range	—	—	189-1890
Fan Qty/Type	—	—	1 / Vane Axial
Fan Diameter (in.)	—	—	16.6 in.
Medium Static 1 Phase			
Motor Qty/Drive Type	—	—	1 / Direct
Maximum Cont Bhp	—	—	0.71
Rpm Range	—	—	219-2190
Fan Qty/Type	—	—	1 / Vane Axial
Fan Diameter (in.)	—	—	16.6 in.
High Static 1 Phase			
Motor Qty/Drive Type	—	—	1 / Direct
Maximum Cont Bhp	—	—	1.07
Rpm Range	—	—	249-2490
Fan Qty/Type	—	—	1 / Vane Axial
Fan Diameter (in.)	—	—	16.6 in.
Standard Static 3 Phase			
Motor Qty/Drive Type	1 / Direct	1 / Direct	—
Maximum Cont Bhp	0.44	0.44	—
Rpm Range	189-1890	189-1890	—
Fan Qty/Type	1 / Vane Axial	1 / Vane Axial	—
Fan Diameter (in.)	16.6 in.	16.6 in.	—
Medium Static 3 Phase			
Motor Qty/Drive Type	1 / Direct	1 / Direct	—
Maximum Cont Bhp	0.71	0.71	—
Rpm Range	219-2190	219-2190	—
Fan Qty/Type	1 / Vane Axial	1 / Vane Axial	—
Fan Diameter (in.)	16.6 in.	16.6 in.	—

Physical data (cont)



48/50GC 3 Ton Physical Data (cont)

48/50GC UNIT	48/50GC*J04	48/50GC*K04	48/50GC*T04
High Static 3 Phase			
Motor Qty/Drive Type	1 / Direct	1 / Direct	—
Maximum Cont Bhp	1.07	1.07	—
Rpm Range	249-2490	249-2490	—
Fan Qty/Type	1 / Vane Axial	1 / Vane Axial	—
Fan Diameter (in.)	16.6 in.	16.6 in.	—
CONDENSER FAN AND MOTOR			
Qty / Motor Drive Type	1 / Direct	1 / Direct	1 / Direct
Motor HP/Rpm	1/3 / 1000/800	1/3 / 1000/800	1/3 / 1000/800
Fan Diameter (in.)	23 in.	23 in.	23 in.
FILTERS			
RA Filter Qty / Size (in.)	2 / 16 x 25 x 2	2 / 16 x 25 x 2	2 / 16 x 25 x 2
OA Inlet Screen Qty / Size (in.)	1 / 20 x 24 x 1	1 / 20 x 24 x 1	1 / 20 x 24 x 1

NOTE(S):

- a. Base unit operating weight does not include weight of options.

LEGEND

- Bhp** — Break Horsepower
- FPI** — Fins Per Inch
- OA** — Outdoor Air
- RA** — Return Air

48/50GC 4 Ton Physical Data

48/50GC UNIT	48/50GC*J05	48/50GC*K05	48/50GC*T05
NOMINAL TONS	4	4	4
BASE UNIT OPERATING WT (lb) 48GC/50GC^a	555/510	555/510	555/510
REFRIGERATION SYSTEM			
No. Circuits/No. Compressors/Type	1 / 1 / 2-Stage Scroll	1 / 1 / 2-Stage Scroll	1 / 1 / 2-Stage Scroll
Puron® (R-410A) Charge A/B (lb-oz)	9	—	9
Humidi-MiZer® Puron (R-410A) Charge A/B (lb-oz)	—	12-12	—
Metering Device	TXV	—	TXV
Humidi-MiZer Metering Device	—	TXV	—
High-Pressure Trip/Reset (psig)	630/505	630/505	630/505
Low-Pressure Trip/Reset (psig)	54/117	27/44	54/117
EVAPORATOR COIL			
Material (Tube/Fin)	Cu/Al	Cu/Al	Cu/Al
Coil Type	3/8 in. RTPF	3/8 in. RTPF	3/8 in. RTPF
Rows/FPI	4/15	4/15	4/15
Total Face Area (ft ²)	5.5	5.5	5.5
Condensate Drain Connection Size	3/4 in.	3/4 in.	3/4 in.
CONDENSER COIL			
Material	Cu/Al	Cu/Al	Cu/Al
Coil Type	5/16 in. RTPF	5/16 in. RTPF	5/16 in. RTPF
Rows/FPI	2/18	2/18	2/18
Total Face Area (ft ²)	15.9	15.9	15.9
HUMIDI-MIZER COIL			
Material	—	Cu/Al	—
Coil Type	—	3/8 in. RTPF	—
Rows/FPI	—	2/17	—
Total Face Area (ft ²)	—	4.1	—
EVAPORATOR FAN AND MOTOR			
Standard Static 1 Phase			
Motor Qty/Drive Type	—	—	1 / Direct
Maximum Cont Bhp	—	—	0.72
Rpm Range	—	—	190-1900
Fan Qty/Type	—	—	1 / Vane Axial
Fan Diameter (in.)	—	—	16.6 in.
Medium Static 1 Phase			
Motor Qty/Drive Type	—	—	1 / Direct
Maximum Cont Bhp	—	—	1.06
Rpm Range	—	—	217-2170
Fan Qty/Type	—	—	1 / Vane Axial
Fan Diameter (in.)	—	—	16.6 in.
High Static 1 Phase			
Motor Qty/Drive Type	—	—	1 / Direct
Maximum Cont Bhp	—	—	1.53
Rpm Range	—	—	246-2460
Fan Qty/Type	—	—	1 / Vane Axial
Fan Diameter (in.)	—	—	16.6 in.
Standard Static 3 Phase			
Motor Qty/Drive Type	1 / Direct	1 / Direct	—
Maximum Cont Bhp	0.72	0.72	—
Rpm Range	190-1900	190-1900	—
Fan Qty/Type	1 / Vane Axial	1 / Vane Axial	—
Fan Diameter (in.)	16.6 in.	16.6 in.	—
Medium Static 3 Phase			
Motor Qty/Drive Type	1 / Direct	1 / Direct	—
Maximum Cont Bhp	1.06	1.06	—
Rpm Range	217-2170	217-2170	—
Fan Qty/Type	1 / Vane Axial	1 / Vane Axial	—
Fan Diameter (in.)	16.6 in.	16.6 in.	—

Physical data (cont)



48/50GC 4 Ton Physical Data (cont)

48/50GC UNIT	48/50GC*J05	48/50GC*K05	48/50GC*T05
High Static 3 Phase			
Motor Qty/Drive Type	1 / Direct	1 / Direct	—
Maximum Cont Bhp	1.96	1.96	—
Rpm Range	266-2660	266-2660	—
Fan Qty/Type	1 / Vane Axial	1 / Vane Axial	—
Fan Diameter (in.)	16.6 in.	16.6 in.	—
CONDENSER FAN AND MOTOR			
Qty / Motor Drive Type	1 / Direct	1 / Direct	1 / Direct
Motor HP/Rpm	1/3 / 1000/800	1/3 / 1000/800	1/3 / 1000/800
Fan Diameter (in.)	250	250	250
FILTERS			
RA Filter Qty / Size (in.)	2 / 16 x 25 x 2	2 / 16 x 25 x 2	2 / 16 x 25 x 2
OA Inlet Screen Qty / Size (in.)	1 / 20 x 24 x 1	1 / 20 x 24 x 1	1 / 20 x 24 x 1

NOTE(S):

a. Base unit operating weight does not include weight of options.

LEGEND

- Bhp** — Break Horsepower
- FPI** — Fins Per Inch
- OA** — Outdoor Air
- RA** — Return Air

48/50GC 5 Ton Physical Data

48/50GC UNIT	48/50GC*J06	48/50GC*K06	48/50GC*T06
NOMINAL TONS	5	5	5
BASE UNIT OPERATING WT (lb) 48GC/50GC^a	600/555	600/555	600/555
REFRIGERATION SYSTEM			
No. Circuits/No. Compressors/Type	1 / 1 / 2-Stage Scroll	1 / 1 / 2-Stage Scroll	1 / 1 / 2-Stage Scroll
Puron® (R-410A) Charge A/B (lb-oz)	11-0	—	11-0
Humidi-MiZer® Puron (R-410A) Charge A/B (lb-oz)	—	18-0	—
Metering Device	TXV	—	TXV
Humidi-MiZer Metering Device	—	TXV	—
High-Pressure Trip/Reset (psig)	630/505	630/505	630/505
Low-Pressure Trip/Reset (psig)	54/117	27/44	54/117
EVAPORATOR COIL			
Material (Tube/Fin)	Cu/Al	Cu/Al	Cu/Al
Coil Type	3/8 in. RTPF	3/8 in. RTPF	3/8 in. RTPF
Rows/FPI	4/15	4/15	4/15
Total Face Area (ft ²)	7.3	7.3	7.3
Condensate Drain Connection Size	3/4 in.	3/4 in.	3/4 in.
CONDENSER COIL			
Material	Cu/Al	Cu/Al	Cu/Al
Coil Type	5/16 in. RTPF	5/16 in. RTPF	5/16 in. RTPF
Rows/FPI	2/18	2/18	2/18
Total Face Area (ft ²)	18.8	18.8	18.8
HUMIDI-MIZER COIL			
Material	—	Cu/Al	—
Coil Type	—	3/8 in. RTPF	—
Rows/FPI	—	2/17	—
Total Face Area (ft ²)	—	5.5	—
EVAPORATOR FAN AND MOTOR			
Standard Static 1 Phase			
Motor Qty/Drive Type	—	—	1 / Direct
Maximum Cont Bhp	—	—	1.06
Rpm Range	—	—	215-2150
Fan Qty/Type	—	—	1 / Vane Axial
Fan Diameter (in.)	—	—	16.6 in.
Medium Static 1 Phase			
Motor Qty/Drive Type	—	—	1 / Direct
Maximum Cont Bhp	—	—	1.44
Rpm Range	—	—	239-2390
Fan Qty/Type	—	—	1 / Vane Axial
Fan Diameter (in.)	—	—	16.6 in.
Standard Static 3 Phase			
Motor Qty/Drive Type	1 / Direct	1 / Direct	—
Maximum Cont Bhp	1.06	1.06	—
Rpm Range	215-2150	215-2150	—
Fan Qty/Type	1 / Vane Axial	1 / Vane Axial	—
Fan Diameter (in.)	16.6 in.	16.6 in.	—
Medium Static 3 Phase			
Motor Qty/Drive Type	1 / Direct	1 / Direct	—
Maximum Cont Bhp	1.44	1.44	—
Rpm Range	239-2390	239-2390	—
Fan Qty/Type	1 / Vane Axial	1 / Vane Axial	—
Fan Diameter (in.)	16.6 in.	16.6 in.	—

Physical data (cont)



48/50GC 5 Ton Physical Data (cont)

48/50GC UNIT	48/50GC*J06	48/50GC*K06	48/50GC*T06
High Static 3 Phase			
Motor Qty/Drive Type	1 / Direct	1 / Direct	—
Maximum Cont Bhp	2.43	2.43	—
Rpm Range	284-2836	284-2836	—
Fan Qty/Type	1 / Vane Axial	1 / Vane Axial	—
Fan Diameter (in.)	16.6 in.	16.6 in.	—
CONDENSER FAN AND MOTOR			
Qty / Motor Drive Type	1 / Direct	1 / Direct	1 / Direct
Motor HP/Rpm	1/3 / 1000/1000	1/3 / 1000/1000	1/3 / 1000/1000
Fan Diameter (in.)	250	250	250
FILTERS			
RA Filter Qty / Size (in.)	4 / 16 x 16 x 2	4 / 16 x 16 x 2	4 / 16 x 16 x 2
OA Inlet Screen Qty / Size (in.)	1 / 20 x 24 x 1	1 / 20 x 24 x 1	1 / 20 x 24 x 1

NOTE(S):

a. Base unit operating weight does not include weight of options.

LEGEND

- Bhp** — Break Horsepower
- FPI** — Fins Per Inch
- OA** — Outdoor Air
- RA** — Return Air

48GC 3 to 5 Ton Gas Heat Data — 1-Phase Units

48GC UNIT	48GC**04	48GC**05	48GC**06
GAS CONNECTION			
No. of Gas Valves	1	1	1
Natural Gas Supply Line Pressure (in. wg)/ (psig)	4-13 / 0.14-0.47	4-13 / 0.14-0.47	4-13 / 0.14-0.47
Liquid Propane Supply Line Pressure (in. wg)/ (psig)	11-13 / 0.40-0.47	11-13 / 0.40-0.47	11-13 / 0.40-0.47
HEAT ANTICIPATOR SETTING (AMPS)			
First Stage	0.14	0.14	0.14
Second Stage	0.14	0.14	0.14
NATURAL GAS HEAT			
LOW			
No. of Stages / No. of Burners (total)	1 / 2	1 / 2	1 / 2
Connection Size	1/2 in. NPT	1/2 in. NPT	1/2 in. NPT
Rollout Switch Opens / Closes (°F)	195 / 115	195 / 115	195 / 115
Temperature Rise (°F)	25-55	20-55	15-55
MEDIUM			
No. of Stages / No. of Burners (total)	1 / 3	1 / 3	1 / 3
Connection Size	1/2 in. NPT	1/2 in. NPT	1/2 in. NPT
Rollout Switch Opens / Closes (°F)	195 / 115	195 / 115	195 / 115
Temperature Rise (°F)	45-85	30-65	25-65
HIGH			
No. of Stages / No. of Burners (total)	—	1 / 3	1 / 3
Connection Size	—	1/2 in. NPT	1/2 in. NPT
Rollout Switch Opens / Closes (°F)	—	195 / 115	195 / 115
Temperature Rise (°F)	—	45-80	35-80
LIQUID PROPANE HEAT			
LOW			
No. of Stages / No. of Burners (total)	1 / 2	1 / 2	1 / 2
Connection Size	1/2 in. NPT	1/2 in. NPT	1/2 in. NPT
Rollout Switch Opens / Closes (°F)	195 / 115	195 / 115	195 / 115
Temperature Rise (°F)	25-55	20-55	15-55
MEDIUM			
No. of Stages / No. of Burners (total)	1 / 3	1 / 3	1 / 3
Connection Size	1/2 in. NPT	1/2 in. NPT	1/2 in. NPT
Rollout Switch Opens / Closes (°F)	195 / 115	195 / 115	195 / 115
Temperature Rise (°F)	45-85	30-65	25-65
HIGH			
No. of Stages / No. of Burners (total)	—	1 / 3	1 / 3
Connection Size	—	1/2 in. NPT	1/2 in. NPT
Rollout Switch Opens / Closes (°F)	—	195 / 115	195 / 115
Temperature Rise (°F)	—	45-80	35-80
LOW NOx HEAT			
LOW			
No. of Stages / No. of Burners (total)	1 / 2	1 / 2	1 / 2
Connection Size	1/2 in. NPT	1/2 in. NPT	1/2 in. NPT
Rollout Switch Opens / Closes (°F)	195 / 115	195 / 115	195 / 115
Temperature Rise (°F)	20-50	20-50	15-50

48GC 3 to 6 Ton Gas Heat Data — 3-Phase Units

48GC UNIT	48GC**04	48GC**05	48GC**06
GAS CONNECTION			
No. of Gas Valves	1	1	1
Natural Gas Supply Line Pressure (in. wg)/ (psig)	4-13 / 0.14-0.47	4-13 / 0.14-0.47	4-13 / 0.14-0.47
Liquid Propane Supply Line Pressure (in. wg)/ (psig)	11-13 / 0.40-0.47	11-13 / 0.40-0.47	11-13 / 0.40-0.47
HEAT ANTICIPATOR SETTING (AMPS)			
First Stage	0.14	0.14	0.14
Second Stage	0.14	0.14	0.14
NATURAL GAS HEAT			
LOW			
No. of Stages / No. of Burners (total)	2 / 2	2 / 2	2 / 2
Connection Size	1/2 in. NPT	1/2 in. NPT	1/2 in. NPT
Rollout Switch Opens / Closes (°F)	195 / 115	195 / 115	195 / 115
Temperature Rise (°F)	25-55	25-55	20-55
MEDIUM			
No. of Stages / No. of Burners (total)	2 / 3	2 / 3	2 / 3
Connection Size	1/2 in. NPT	1/2 in. NPT	1/2 in. NPT
Rollout Switch Opens / Closes (°F)	195 / 115	195 / 115	195 / 115
Temperature Rise (°F)	50-85	35-65	30-65
HIGH			
No. of Stages / No. of Burners (total)	—	2 / 3	2 / 3
Connection Size	—	1/2 in. NPT	1/2 in. NPT
Rollout Switch Opens / Closes (°F)	—	195 / 115	195 / 115
Temperature Rise (°F)	—	50-80	40-80
LIQUID PROPANE HEAT			
LOW			
No. of Stages / No. of Burners (total)	2 / 2	2 / 2	2 / 2
Connection Size	1/2 in. NPT	1/2 in. NPT	1/2 in. NPT
Rollout Switch Opens / Closes (°F)	195 / 115	195 / 115	195 / 115
Temperature Rise (°F)	25-55	25-55	20-55
MEDIUM			
No. of Stages / No. of Burners (total)	2 / 3	2 / 3	2 / 3
Connection Size	1/2 in. NPT	1/2 in. NPT	1/2 in. NPT
Rollout Switch Opens / Closes (°F)	195 / 115	195 / 115	195 / 115
Temperature Rise (°F)	50-85	35-65	30-65
HIGH			
No. of Stages / No. of Burners (total)	—	2 / 3	2 / 3
Connection Size	—	1/2 in. NPT	1/2 in. NPT
Rollout Switch Opens / Closes (°F)	—	195 / 115	195 / 115
Temperature Rise (°F)	—	50-80	40-80
LOW NOx HEAT			
LOW			
No. of Stages / No. of Burners (total)	1 / 2	1 / 2	1 / 2
Connection Size	1/2 in. NPT	1/2 in. NPT	1/2 in. NPT
Rollout Switch Opens / Closes (°F)	195 / 115	195 / 115	195 / 115
Temperature Rise (°F)	20-50	20-50	15-50

Options and accessories



ITEM	FACTORY-INSTALLED OPTION	FIELD-INSTALLED ACCESSORY
GAS HEAT (48GC units only)		
Low, Medium or High Gas Heat — Aluminized Heat Exchanger	X	
Low, Medium or High Gas Heat — Stainless Steel Heat Exchanger	X	
Low NOx, Low Heat — Stainless Steel Heat Exchanger	X	
Propane Conversion Kit		X
High Altitude Conversion Kit		X
Flue Discharge Deflector		X
Flue Shield		X
ELECTRIC HEAT (50GC units only)		
Electric Resistance Heaters	X	X
Single Point Kits		X
CABINET		
Thru-the-Base Electrical or Gas-Line Connections	X	X
Hinged Access Panels	X	
COIL OPTIONS		
Cu/Cu Indoor and/or Outdoor Coils ^a	X	
Pre-coated Outdoor Coils ^a	X	
Premium, E-coated Outdoor Coils ^a	X	
HUMIDITY CONTROL		
Humidi-MiZer [®] Adaptive Dehumidification System ^a	X	
CONDENSER PROTECTION		
Condenser Coil Hail Guard (louvered design) ^a	X	X
CONTROLS		
Thermostats, Temperature Sensors, and Subbases		X
SystemVu™ DDC Communicating Controller	X	
RTU Open Multi-Protocol Controller	X	
Smoke Detector (supply and/or return air)	X	
Horn Strobe Annunciator ^b		X
Time Guard II Compressor Delay Control Circuit		X
Phase Monitor		X
Condensate Overflow Switch	X	X
FILTERS		
MERV-13 Return Air Filters	X	X
ECONOMIZERS AND OUTDOOR AIR DAMPERS		
EconomizerONE for Electromechanical Controls, complies with FDD (Standard and Ultra Low Leak damper models) ^{a,c}	X	X
Wi-Fi Stick for EconomizerONE (optional)		X
EconoMi\$er [®] 2 for DDC Controls (Standard and Ultra Low Leak air damper models) ^{a,d}	X	X
Motorized Two-Position Outdoor-Air Damper ^a		X
Manual Outdoor-Air Damper (25% and 50%)		X
Barometric Relief ^e	X	X
Power Exhaust — Prop Design		X

ITEM	FACTORY-INSTALLED OPTION	FIELD-INSTALLED ACCESSORY
ECONOMIZER SENSORS AND IAQ DEVICES		
Single Dry Bulb Temperature Sensors ^f	X	X
Differential Dry Bulb Temperature Sensors ^f		X
Single Enthalpy Sensors ^f	X	X
Differential Enthalpy Sensors ^f		X
CO ₂ Sensor (wall, duct, or unit mounted) ^f	X	X
INDOOR MOTOR AND DRIVE		
Multiple Motor and Drive Packages	X	
LOW AMBIENT CONTROL		
Winter Start Kit ^g		X
Low Ambient Controller to -20°F (-29°C) ^g	X	X
POWER OPTIONS		
Convenience Outlet (powered) ^a	X	
Convenience Outlet (unpowered)	X	
HACR Circuit Breaker ^h	X	
Non-Fused Disconnect ⁱ	X	
ROOF CURBS		
Roof Curb 14 in. (356 mm)		X
Roof Curb 24 in. (610 mm)		X

NOTE(S):

- Not available as a factory-installed option on single phase (-3 voltage code) models. Use field-installed accessory where available.
- Requires a field-supplied 24V transformer for each application. See price pages for details.
- FDD (Fault Detection and Diagnostic) capability per California Title 24 section 120.2.
- Models with SystemVu and RTU Open DDC controls comply with California Title 24 Fault Detection and Diagnostic (FDD).
- Included with economizer.
- Sensors used to optimize economizer performance.
- See application data for assistance.
- HACR circuit breaker cannot be used on 04-06 sizes when unit FLA electrical rating exceeds:
208/230/1/60 and 208/230/3/60 = 100 amps (FLA)
460/3/60 = 90 amps (FLA)
Carrier RTUBuilder automatically selects the amps limitations.
- Non-fused disconnect switch cannot be used when unit electrical rating exceeds:
Without factory-installed electric heat:
208-230/1/60 and 208-230/3/60 = 80 amps (FLA).
480/3/60 and 575/3/60 = 80 amps (FLA).
With factory-installed electric heat:
208-230/1/60 and 208-230/3/60 = 100 amps (FLA).
480/3/60 and 575/3/60 = 80 amps (FLA).
Carrier RTUBuilder automatically selects the amp limitations.

Factory-installed options

Economizer (dry-bulb or enthalpy)

Economizers save money. They bring in fresh, outside air for ventilation; and provide cool, outside air to cool your building. This is the preferred method of low-ambient cooling. When coupled to CO₂ sensors, economizers can provide even more savings by coupling the ventilation air to only that amount required.

Economizers are available, installed and tested by the factory, with either enthalpy or dry-bulb temperature inputs. Additional sensors are available as accessories to optimize the economizers. Economizers include a powered exhaust system to help equalize building pressures.

Economizers include gravity controlled barometric relief that helps equalize building pressure and ambient air pressures. This can be a cost effective solution to prevent building pressurization. Economizers are available in Ultra Low Leak and standard low leak versions. Economizers can be factory-installed or easily field-installed.

Unit mounted CO₂ sensor

The CO₂ sensor works with the economizer to intake only the correct amount of outside air for ventilation. As occupants fill your building, the CO₂ sensor detects their presence through increasing CO₂ levels, and opens the economizer appropriately. When the occupants leave, the CO₂ levels decrease, and the sensor appropriately closes the economizer. This intelligent control of the ventilation air, called demand controlled ventilation (DCV) reduces the overall load on the rooftop, saving money. Also available as a field-installed accessory.

Smoke detector (supply and/or return air)

Trust the experts. Smoke detectors make your application safer and your job easier. Carrier smoke detectors immediately shut down the rooftop unit when smoke is detected. They are available, installed by the factory, for supply air, return air, or both.

Optional Humidi-MiZer[®] adaptive dehumidification system

Carrier's Humidi-MiZer adaptive dehumidification system is an all-inclusive factory-installed option that can be ordered with any WeatherMaster[®] 48/50GC04-06 rooftop unit, with the exception of single phase voltage (208-230/1/60) units.

This system expands the envelope of operation of Carrier's WeatherMaker rooftop products to provide unprecedented flexibility to meet year round comfort conditions.

The Humidi-MiZer adaptive dehumidification system has a unique dual operational mode setting. The Humidi-MiZer system provides greater dehumidification of the occupied space by 2 modes of dehumidification operations in addition to its normal design cooling mode.

The WeatherMaster 48/50GC04-06 rooftop coupled with the Humidi-MiZer system is capable of operating in normal design cooling mode, sub-cooling mode, and hot gas reheat mode. Normal design cooling mode is when the unit will operate under its normal sequence of operation by cycling compressors to maintain comfort conditions.

Sub-cooling mode will operate to satisfy part load type conditions when the space requires combined sensible and a higher proportion of latent load control. Hot Gas Reheat mode will operate when outdoor temperatures diminish and the need for latent capacity is required for sole

humidity control Hot Gas Reheat mode will provide neutral air for maximum dehumidification operation.

NOTE: Humidi-MiZer system includes Low Ambient controller.

Thru-the-base connection

Thru-the-base connections, available as a factory option, are necessary to ensure proper connection and seal when routing wire and piping through the rooftop's basepan and curb. These couplings eliminate roof penetration and should be considered for gas lines, main power lines, as well as control power.

Hinged access panels

Allows access to unit's major components with specifically designed hinged access panels. Panels are filter, control box access indoor fan motor access.

Cu/Cu (indoor) coils

Copper fins and copper tubes are mechanically bonded to copper tubes and copper tube sheets. A polymer strip prevents coil assembly from contacting the sheet metal coil pan to minimize potential for galvanic corrosion between coil and pan.

E-coated (outdoor and indoor) coils

A flexible epoxy polymer coating uniformly applied to all coil surface areas without material bridging between fins. Coating process shall ensure complete coil encapsulation of tubes, fins and headers.

Pre-coated outdoor coils

A durable epoxy-phenolic coating to provide protection in mildly corrosive coastal environments. The coating minimizes galvanic action between dissimilar metals. Coating is applied to the aluminum fin stock prior to the fin stamping process to create an inert barrier between the aluminum fin and copper tube.

Condenser coil hail guard

Sleek, louvered panels protect the condenser coil from hail damage, foreign objects, and incidental contact.

Single enthalpy sensor

Prevents the wheel from rotating if the outside air conditions are acceptable for free cooling. Both exhaust and supply blowers will remain on.

Stainless steel heat exchanger (48GC units only)

The stainless steel heat exchanger option provides the tubular heat exchanger be made out of a minimum 20 gauge type 409 stainless steel for applications where the mixed air to the heat exchanger is expected to drop below 45°F (7°C). Stainless steel may be specified on applications where the presence of airborne contaminants requires its use (applications such as paper mills) or in area with very high outdoor humidity that may result in severe condensation in the heat exchanger during cooling operation.

Convenience outlet (powered or un-powered)

Reduce service and/or installation costs by including a convenience outlet in your specification. Carrier will install this service feature at our factory. Provides a convenient, 15 amp, 115v GFCI receptacle with "Wet in Use" cover. The "powered" option allows the installer to power the outlet from the line side of the disconnect or load side as

required by code. The “unpowered” option is to be powered from a separate 115/120-v power source.

The unpowered convenience outlet is available as a 15 amp factory-installed option or a 20 amp field-installed accessory.

HACR Breaker

These manual reset devices provide overload and short circuit protection for the unit. Factory wired and mounted with the units with access cover to provide protection from the environment.

Non-fused disconnect

This OSHA-compliant, factory-installed, safety switch allows a service technician to locally secure power to the rooftop. When selecting a factory-installed non-fused disconnect, note they are sized for the unit as ordered from the factory. The sizing of these do not accommodate field-installed items such as power exhaust devices, etc. If field installing electric heat with factory-installed non-fused disconnect switch, a single point kit may or may not be required.

SystemVu™ controller

Carrier’s SystemVu controller is an optional factory-installed and tested controller.

This controller takes on a whole new approach to provide an intuitive, intelligent controller that not only monitors and controls the unit, but also provides linkage to multiple building automation systems.

Each SystemVu controller makes it easy to set up, service, troubleshoot, gain historical data, generate reports and provide comfort only Carrier is noted for.

Key features include:

- Easy to read back lit 4 line text screen for superior visibility.
- Quick operational condition LEDs of: Run, Alert, and Fault.
- Simple navigation with large keypad buttons of: Navigation arrows, Test, Back, Enter and Menu.
- Capable of being controlled with a conventional thermostat, space sensor or build automation system.
- Service capabilities include:
 - Auto run test
 - Manual run test
 - Component run hours and starts
 - Commissioning reports
 - Data logging
- Full range of diagnosis:
 - Read refrigerant pressures without the need of gauges
 - Sensor faults
 - Compressor reverse rotation
 - Economizer diagnostics that meet California Title 24 requirements
- Quick data transfer via USB port:
 - Unit configuration uploading/downloading
 - Data logging
 - Software upgrades
- Built in capacity for:
 - i-Vu® open systems
 - BACnet systems
 - CCN systems

- Configuration and alarm point capability:
 - Contain over 100 alarm codes
 - Contain over 260 status, troubleshooting, diagnostic and maintenance points
 - Contain over 270 control configuration setpoints

RTU Open, multi-protocol controller

Connect the rooftop to an existing BAS (building automation system) without needing complicated translators or adapter modules using the RTU Open controller. The RTU Open controller speaks the 4 most common building automation system languages (BACnet, Modbus, Johnson Controls N2, and LonWorks). Use this controller when you have an existing BAS. Besides the 4 protocols, it also communicates with a Carrier Open system (i-Vu and VVT®).

Condensate overflow switch

This sensor and related controller monitors the condensate level in the drain pan and shuts down compression operation when overflow conditions occur. It includes:

- Indicator light — solid red (more than 10 seconds on water contact — compressors disabled), blinking red (sensor disconnected)
- 10 second delay to break — eliminates nuisance trips from splashing or waves in pan (sensor needs 10 seconds of constant water contact before tripping)
- Disables the compressor(s) operation when condensate plug is detected, but still allows fans to run for economizer.

MERV-13 return air filters

This factory option upgrades the return air filters from standard unit filters to high efficiency MERV-13 filters. Non-woven MERV-13 filter media with high strength, moisture-resistant frame. Filter media is securely fastened inside the filter frame on all 4 sides.

Low ambient controller

The low ambient controller is a head pressure controller kit that is designed to maintain the unit’s condenser head pressure during periods of low ambient cooling operation. This device should be used as an alternative to economizer free cooling when economizer usage is either not appropriate or desired. The low ambient controller will either cycle the outdoor fan motors or operate them at reduced speed to maintain the unit operation, depending on the model. This controller allows cooling operation down to -20°F (-29°C) ambient conditions.

Electric heaters

Carrier offers a full-line of field-installed accessory heaters. The heaters are very easy to use, install and are all pre-engineered and certified. Electric heaters are available as either factory-installed options or field-installed accessories.

Field-installed accessories

Filter maintenance indicator

When the optional factory-installed filter maintenance indicator is used, a factory-installed differential pressure switch measures pressure drop across the outside air filter and activates a field-supplied dry contact indicator when the pressure differential exceeds the adjustable switch setpoint.

Condenser coil hail guard

Sleek, louvered panels protect the condenser coil from hail damage, foreign objects, and incidental contact. This can be purchased as a factory-installed option or as a field-installed accessory.

Differential enthalpy sensor

The differential enthalpy sensor is comprised of an outdoor and return air enthalpy sensors to provide differential enthalpy control. The sensor allows the unit to determine if outside air is suitable for free cooling.

Wall or duct mounted CO₂ sensor

The IAQ sensor shall be available in duct or wall mount. The sensor provides demand ventilation indoor air quality (IAQ) control.

Propane conversion kit (48GC units only)

Convert your gas heat rooftop from standard natural gas operation to Propane using this field-installed kit.

High altitude conversion kit (48GC units only)

High altitudes have less oxygen, which affects the fuel/air mixture in heat exchangers. In order to maintain a proper fuel/air mixture, heat exchangers operating in altitudes above 2000 ft (610 m) require different orifices. To select the correct burner orifices or determine the heat capacity for a high altitude application, use either the selection software, or the unit's service manual. High altitudes have less oxygen, which means heat exchangers need less fuel. The new gas orifices in this field-installed kit make the necessary adjustment for high altitude applications. They restore the optimal fuel to air mixture and maintain healthy combustion on altitudes above 2000 ft (610 m).

NOTE: Typical natural gas heating value ranges from 975 to 1050 Btu/ft³ at sea level nationally. The heating value goes down approximately 1.7% per every thousand feet elevation. Standard factory orifices can typically be used up to 2000 ft (610 m) elevation without any operational issues.

Flue discharge deflector (48GC units only)

The flue discharge deflector is a useful accessory when flue gas recirculation is a concern. By venting the flue discharge upwards, the deflector minimizes the chance for a neighboring unit to intake the flue exhaust.

Winter start kit

The winter start kit by Carrier extends the low ambient limit of your rooftop to 25°F (-4°C). The kit bypasses the low pressure switch, preventing nuisance tripping of the low pressure switch. Other low ambient precautions may still be prudent.

MERV-13 return air filters

This field-installed accessory upgrades the return air filters from standard unit filters to high efficiency MERV-13 filters. Non-woven MERV-13 filter media with high strength, moisture-resistant frame. Filter media is securely fastened inside the filter frame on all 4 sides.

Low ambient controller

The low ambient controller is a head pressure controller kit that is designed to maintain the unit's condenser head pressure during periods of low ambient cooling operation. This device should be used as an alternative to economizer free cooling not when economizer usage is either not appropriate or desired. The low ambient controller will either cycle the outdoor-fan motors or operate them at reduced speed to maintain the unit operation, depending on the model. This controller allows cooling operation down to -20°F (-29°C) ambient conditions.

Roof curb (14 in./356 mm or 24 in./610 mm)

Full perimeter roof curb with exhaust capability provides separate air streams for energy recovery from the exhaust air without supply air contamination.

Filter status indicator accessory

Monitors static pressure across supply and exhaust filters and provides indication when filters become clogged.

Manual OA damper

Manual outdoor air dampers are an economical way to bring in ventilation air. The dampers are available in 25% and 50% versions.

Motorized two-position damper

The Carrier two-position, motorized outdoor air damper admits up to 100% outside air. Using reliable, gear-driven technology, the 2-position damper opens to allow ventilation air and closes when the rooftop stops, stopping unwanted infiltration.

Time Guard II control circuit

This accessory protects your compressor by preventing short-cycling in the event of some other failure, prevents the compressor from restarting for 30 seconds after stopping. Not required with SystemVu™ controller, RTU Open controller, or authorized commercial thermostats.

Power exhaust

Superior internal building pressure control. This field-installed accessory may eliminate the need for costly, external pressure control fans.

Phase monitor protection

The Phase Monitor Control will monitor the sequence of 3-phase electrical system to provide a phase reversal protection; and monitor the 3-phase voltage inputs to provide a phase loss protection for the 3-phase device. It will work on either a Delta or Wye power connection.

Wi-Fi stick for EconomizerONE (optional)

The accessory Wi-Fi/WLAN stick can be connected to the EconomizerONE POL224 economizer controller via the USB host interface. The Wi-Fi stick enables a wireless connection to be made between a smartphone and the economizer controller via the Climatix™¹ mobile application for commissioning, troubleshooting, and maintenance operations. The Wi-Fi stick is required to utilize the mobile application.

Climatix™ mobile application

The Climatix™ mobile application offers a best-in-class user interface and a simple step-by-step commissioning workflow using a mobile device. The user interface walks users through the setup of the controller and allows users to view the operating mode and parameters. Users can adjust setpoints, initiate damper tests, and save the final configuration as a favorite to expedite setup in the future.

The application is available on Android™¹ and Apple iOS®¹ platforms. The Wi-Fi stick for the EconomizerONE is required to join the Siemens-WiFi-Stick network and setup the controller on a smartphone.

1. Third-party trademarks and logos are the property of their respective owners.

Options and Accessory Weights

OPTION / ACCESSORY NAME ^a	48/50GC UNIT WEIGHT					
	04		05		06	
	lb	kg	lb	kg	lb	kg
Humidi-MiZer® System ^b	15	7	15	7	24	11
Power Exhaust — Vertical	51	23	51	23	51	23
Power Exhaust — Horizontal	39	18	39	18	39	18
EconomizerONE and EconoMiSer® 2	51	23	51	23	51	23
Two-Position Damper	39	18	39	18	39	18
Manual Damper	12	5	12	5	12	5
Medium Gas Heat (48GC units only)	9	4	9	4	9	4
High Gas Heat (48GC units only)	—	—	63	29	63	29
Hail Guard (louvered)	13	6	13	6	17	8
Cu/Cu Condenser Coil	37	17	74	34	90	41
Cu/Cu Condenser and Evaporator Coils	75	34	112	51	160	73
Roof Curb (14 in. curb)	95	43	95	43	95	43
Roof Curb (24 in. curb)	150	68	150	68	150	68
CO ₂ Sensor	2	1	2	1	2	1
Flue Discharge Deflector	7	3	7	3	7	3
Optional Indoor Motor/Drive	10	5	10	5	10	5
Low Ambient Controller	9	4	9	4	9	4
Winter Start Kit	5	2	5	2	5	2
Return Air Smoke Detector	7	3	7	3	7	3
Supply Air Smoke Detector	7	3	7	3	7	3
Fan Filter Switch	2	1	2	1	2	1
Non-Fused Disconnect	15	7	15	7	15	7
Powered Convenience Outlet	36	16	36	16	36	16
Unpowered Convenience Outlet	4	2	4	2	4	2
Enthalpy Sensor	2	1	2	1	2	1
Differential Enthalpy Sensor	3	1	3	1	3	1

NOTE(S):

- Where multiple variations are available, the heaviest combination is listed.
- For Humidi-MiZer system add Low Ambient controller.

48GC**04-06 Base Unit Dimensions

Carrier THIS DOCUMENT IS THE PROPERTY OF CARRIER CORPORATION AND IS DELIVERED UPON THE EXPRESS CONDITION THAT THE CONTENTS WILL NOT BE DISCLOSED OR USED WITHOUT CARRIER CORPORATION'S WRITTEN CONSENT. SUBMISSION OF THESE DRAWINGS OR DOCUMENTS DOES NOT CONSTITUTE PART PERFORMANCE OR ACCEPTANCE OF CONTRACT.

- NOTES:
1. DIMENSIONS ARE IN INCHES, DIMENSIONS IN [] ARE IN MILLIMETERS.
 2. CENTER OF GRAVITY
 3. DIRECTION OF AIR FLOW
 4. ALL VIEW DRAWN USING 3RD ANGLE

UNIT	J	K
48GC**04	33 3/8 [847]	18 5/8 [472]
48GC**05	33 3/8 [847]	14 7/8 [377]
48GC**06	41 3/8 [1051]	18 5/8 [472]

CONNECTION SIZES	
A	1 3/8" [35] DIA FIELD POWER SUPPLY HOLE
B	2" [50] DIA POWER SUPPLY KNOCKOUT
C	1 3/4" [51] DIA GAUGE ACCESS PLUG
D	7/8" [22] DIA FIELD CONTROL WIRING HOLE
E	3/4"-14 NPT CONDENSATE DRAIN
F	1/2"-14 NPT GAS CONNECTION
G	2 1/2" [64] DIA POWER SUPPLY KNOCK-OUT

THRU-THE-BASE CHART THESE HOLES REQUIRED FOR USE C8BTMPW008A00, 009A00			
	THREADED CONDUIT SIZE	WIRE USE	REQ'D HOLE SIZES (MAX.)
W	1/2"	115V	7/8" [22.2]
X	1/2"	24V	7/8" [22.2]
Y	3/4"	POWER	1-1/8" [28.6]
Z*	(009A00) 1/2" FPT	GAS	1-1/8" [28.6]
FOR "THRU-THE-BASEPAN" FACTORY OPTION, FITTINGS FOR ONLY X, Y, & Z ARE PROVIDED			
* (008A00) PROVIDES 3/4" FPT THRU CURB FLANGE & FITTING.			

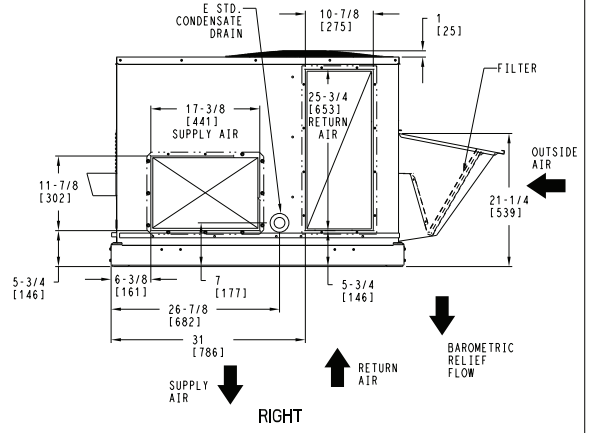
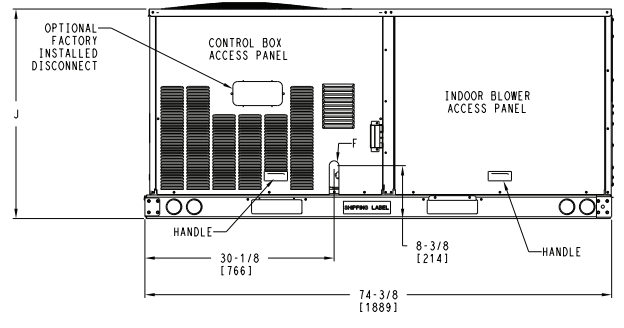
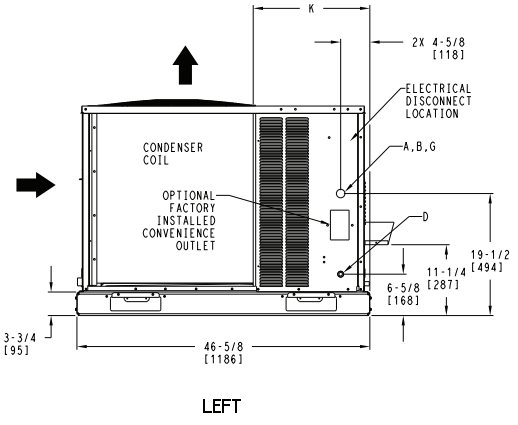
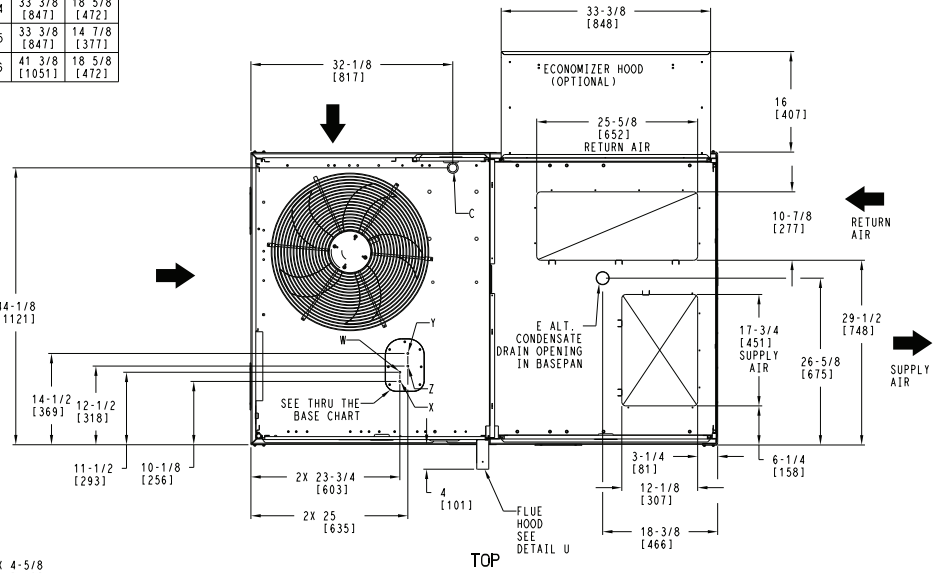
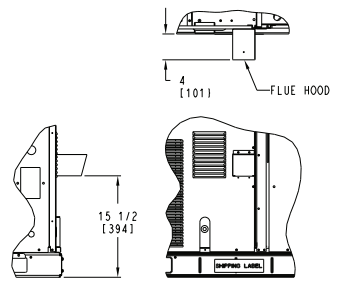

ITC CLASSIFICATION	SHEET	DATE	SUPERCEDES	48GC 04-06 SINGLE PACKAGE ELECTRICAL COOLING WITH GAS HEAT	48TC003099	REV
U.S. ECCN:NSR	1 OF 3	11/17/20	04/02/19			E



48GC**04-06 Base Unit Dimensions (cont)

UNIT	STD. UNIT WEIGHT **		CORNER WEIGHT (A)		CORNER WEIGHT (B)		CORNER WEIGHT (C)		CORNER WEIGHT (D)		C.G.			HEIGHT
	LBS.	KG.	LBS.	KG.	LBS.	KG.	LBS.	KG.	LBS.	KG.	X	Y	Z	
48GC**04	513	233	131	59	127	58	125	57	130	59	36 1/2 [927]	23 1/4 [591]	18 1/4 [464]	
48GC**05	555	252	142	64	137	62	135	61	141	64	36 1/2 [927]	23 1/4 [591]	18 [457]	
48GC**06	600	272	161	73	151	68	140	64	149	68	36 [914]	22 1/2 [572]	19 3/8 [492]	

** STANDARD UNIT WEIGHT IS WITH LOW GAS HEAT AND WITHOUT PACKAGING. FOR OTHER OPTINS AND ACCESSORIES REFER TO THE PRODUCT DATA CATALOG.

THIS TABLE IS FOR "ULTRA LOW NOX" UNITS ONLY

UNIT	STD. UNIT WEIGHT **		CORNER WEIGHT (A)		CORNER WEIGHT (B)		CORNER WEIGHT (C)		CORNER WEIGHT (D)		C.G.			HEIGHT
	LBS.	KG.	LBS.	KG.	LBS.	KG.	LBS.	KG.	LBS.	KG.	X	Y	Z	
48GCC04	543	247	139	63	133	60	133	60	139	63	36 3/8 [924]	23 3/8 [594]	18 [457]	
48GCC05	585	266	149	68	143	65	143	65	149	68	36 3/8 [924]	23 3/8 [594]	18 [457]	
48GCC06	630	286	168	76	157	71	147	69	158	72	35 7/8 [911]	22 5/8 [575]	19 1/2 [489]	

** STANDARD UNIT WEIGHT IS WITHOUT PACKAGING. FOR OTHER OPTINS AND ACCESSORIES REFER TO THE PRODUCT DATA CATALOG.

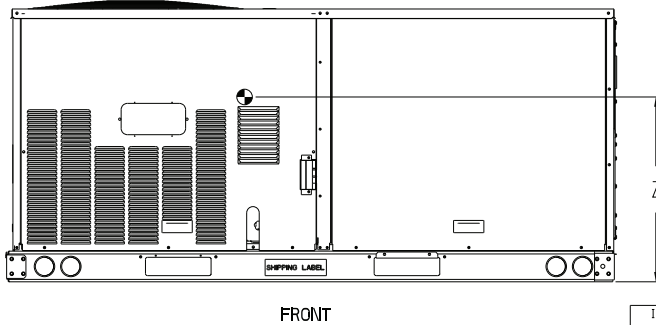
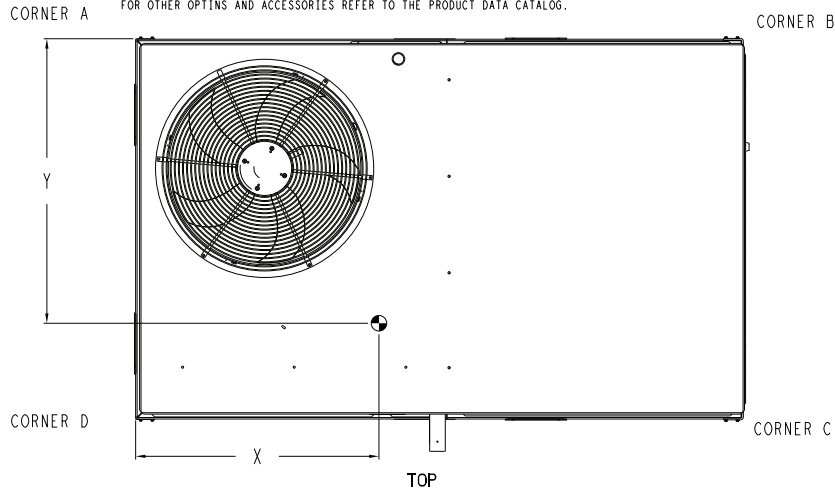

Carrier THIS DOCUMENT IS THE PROPERTY OF CARRIER CORPORATION AND IS DELIVERED UPON THE EXPRESS CONDITION THAT THE CONTENTS WILL NOT BE DISCLOSED OR USED WITHOUT CARRIER CORPORATION'S WRITTEN CONSENT. SUBMISSION OF THESE DRAWINGS OR DOCUMENTS DOES NOT CONSTITUTE PART PERFORMANCE OR ACCEPTANCE OF CONTRACT.

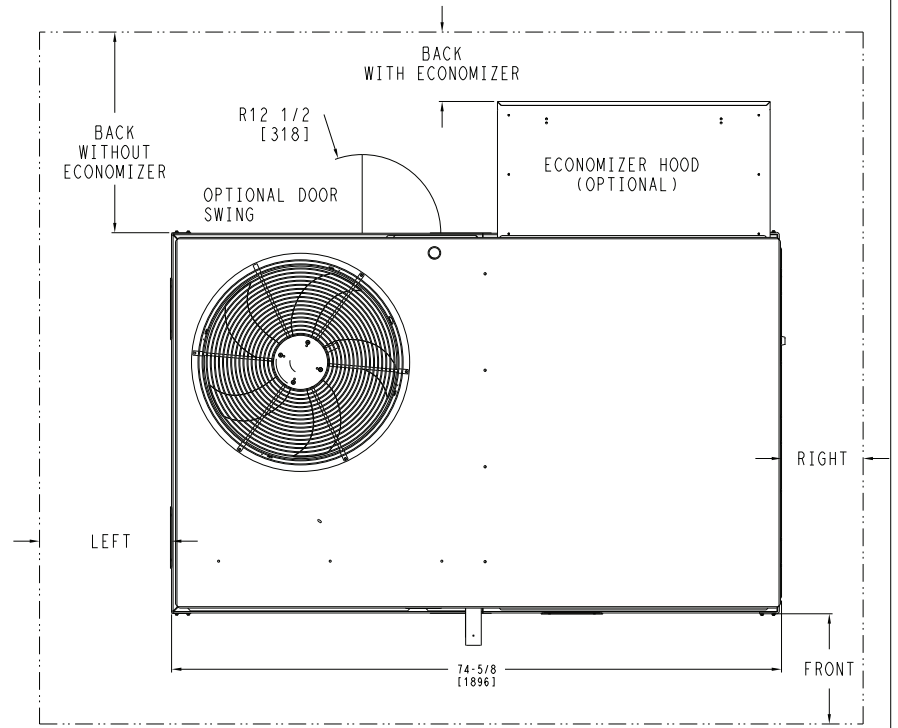

NOTES:

1. FOR ALL MINIMUM CLEARANCES LOCAL CODES OR JURISDICTIONS MAY PREVAIL.

SURFACE	CLEARANCE		OPERATING CLEARANCE
	SERVICE WITH: CONDUCTIVE BARRIER	SERVICE WITH: NONCONDUCTIVE BARRIER	
FRONT	48 [1219mm]	36 [914mm]	18 [457mm]
LEFT	48 [1219mm]	42 [1067mm]	18 [457mm]
BACK W/O HOOD	48 [1219mm]	42 [1067mm]	18 [457mm]
BACK W/HOOD	36 [914mm]	36 [914mm]	18 [457mm]
RIGHT	36 [914mm]	36 [914mm]	18 [457mm]
TOP	72 [1829mm]	72 [1829mm]	72 [1829mm]

ITC CLASSIFICATION U.S. ECCN:NSR	SHEET 2 OF 3	DATE 11/17/20	SUPERCEDES 04/02/19	48GC 04-06 SINGLE PACKAGE ELECTRICAL COOLING WITH GAS HEAT	48TC003099	REV E
-------------------------------------	-----------------	------------------	------------------------	--	------------	----------



48GC**04-06 Base Unit Dimensions (cont)

Carrier THIS DOCUMENT IS THE PROPERTY OF CARRIER CORPORATION AND IS DELIVERED UPON THE EXPRESS CONDITION THAT THE CONTENTS WILL NOT BE DISCLOSED OR USED WITHOUT CARRIER CORPORATION'S WRITTEN CONSENT. SUBMISSION OF THESE DRAWINGS OR DOCUMENTS DOES NOT CONSTITUTE PART PERFORMANCE OR ACCEPTANCE OF CONTRACT.

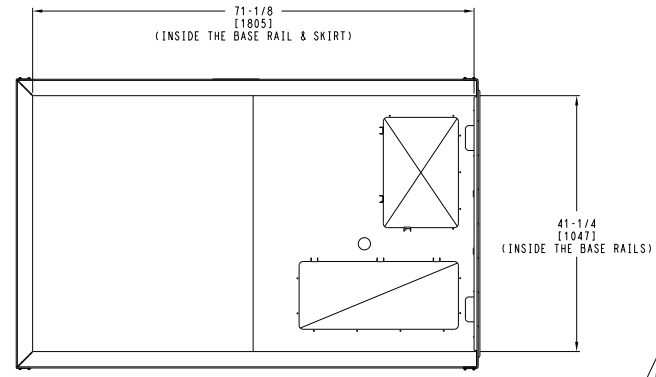
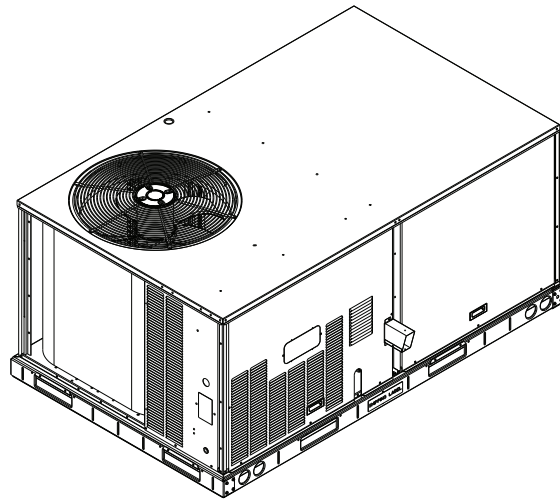

INSIDE BASERAIL DIMENSIONS
BOTTOM

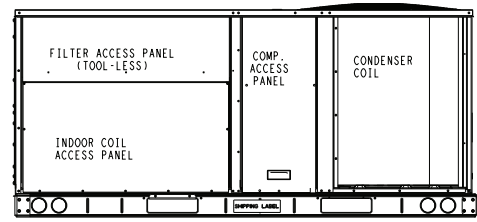
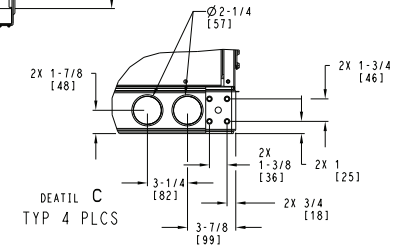

BACK

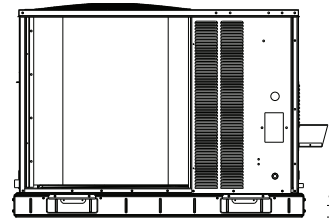

LEFT

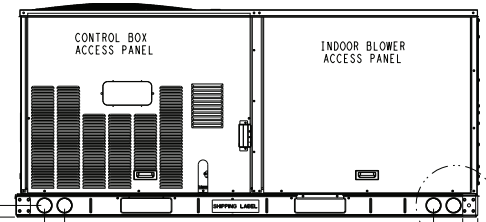

FRONT

ITC CLASSIFICATION U.S. ECCN:NSR	SHEET 3 OF 3	DATE 11/17/20	SUPERCEDES 04/02/19	48GC 04-06 SINGLE PACKAGE ELECTRICAL COOLING WITH GAS HEAT	48TC003099	REV E
-------------------------------------	-----------------	------------------	------------------------	--	------------	----------



50GC-*04-06 Base Unit Dimensions

- NOTES:
1. DIMENSIONS ARE IN INCHES, DIMENSIONS IN [] ARE IN MILLIMETERS.
 2. CENTER OF GRAVITY
 3. DIRECTION OF AIR FLOW
 4. ALL VIEW DRAWN USING 3RD ANGLE

UNIT	J	K
50GC**04	33 3/8 [847]	18 5/8 [472]
50GC**05	33 3/8 [847]	14 7/8 [377]
50GC**06	41 3/8 [1051]	18 5/8 [472]



THIS DOCUMENT IS THE PROPERTY OF UTC CLIMATE, CONTROLS & SECURITY AND IS DELIVERED UPON THE EXPRESS CONDITION THAT THE CONTENTS WILL NOT BE DISCLOSED OR USED WITHOUT WRITTEN CONSENT.

SUBMISSION OF THESE DRAWINGS OR DOCUMENTS DOES NOT CONSTITUTE PART PERFORMANCE OR ACCEPTANCE OF CONTRACT.

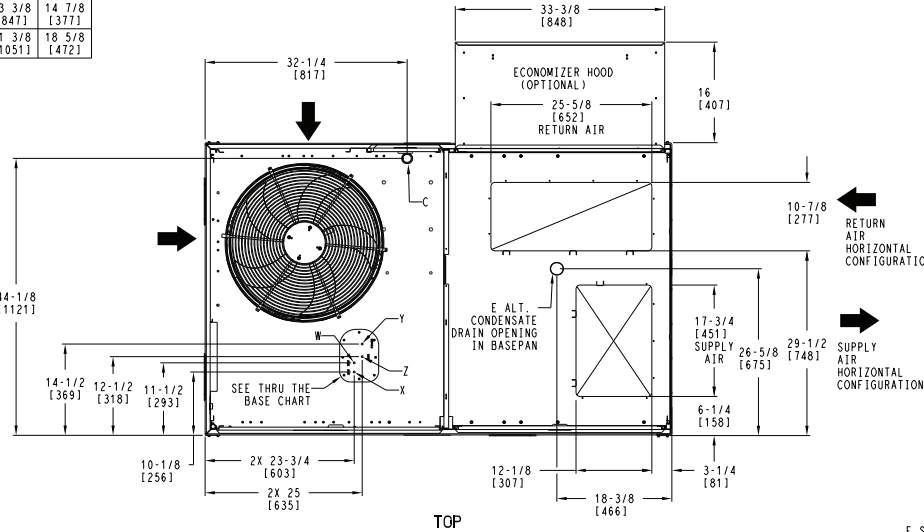

CONNECTION SIZES	
A	1 3/8" [35] DIA. FIELD POWER SUPPLY HOLE
B	2" [51] DIA. POWER SUPPLY KNOCKOUT
C	1 3/4" [44] DIA. GAUGE ACCESS PLUG
D	7/8" [22] DIA. FIELD CONTROL WIRING HOLE
E	3/4"-14 NPT CONDENSATE DRAIN
G	2 1/2" [64] DIA. POWER SUPPLY KNOCK-OUT

THRU-THE-BASE CHART THESE HOLES REQUIRED FOR USE CRBTMPW008A00, 009A00			
	THREADED CONDUIT SIZE	WIRE USE	REQ'D HOLE SIZES (MAX.)
W	1/2"	115V	7/8" [22.2]
X	1/2"	24V	7/8" [22.2]
Y *	3/4"	POWER	1 1/8" [28.6]
Z **	(009A00) 1/2" FPT	GAS	1 1/8" [28.6]

FOR "THRU-THE-BASEPAN" FACTORY OPTION, FITTINGS FOR ONLY X, Y, & Z ARE PROVIDED

* SELECT EITHER 3/4" OR 1/2" FOR POWER, DEPENDING ON WIRE SIZE

** (008A00) PROVIDES 3/4" FPT THRU CURB FLANGE & FITTING.

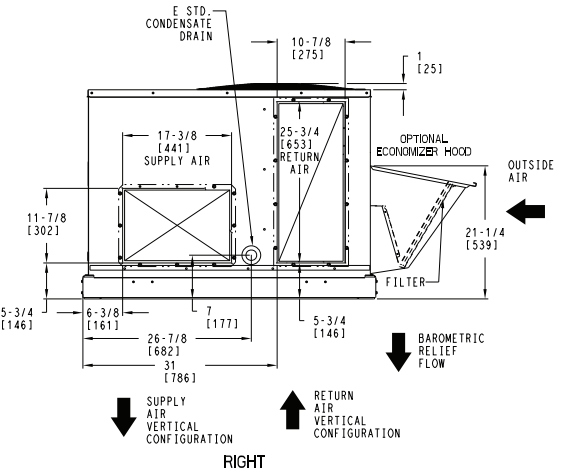
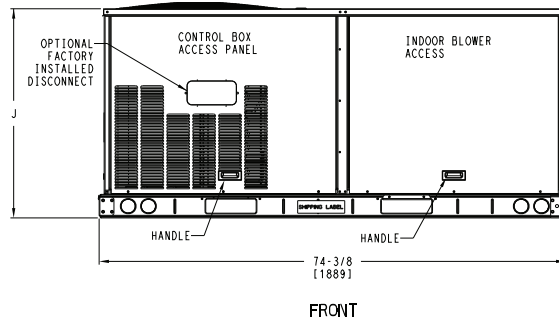
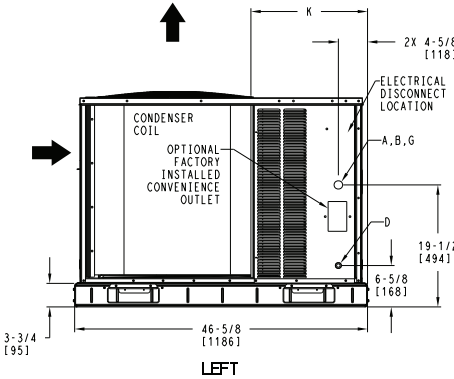

ITC CLASSIFICATION	SHEET	DATE	SUPERCEDES	50GC 04-06 SINGLE PACKAGE ELECTRICAL COOLING WITH ELECTRIC HEAT	48TC003100	REV
U.S. ECCN:NSR	1 OF 3	03/21/19	10/25/18			D

Base unit dimensions (cont)



50GC-*04-06 Base Unit Dimensions (cont)

UNIT	STD. UNIT WEIGHT *		CORNER WEIGHT (A)		CORNER WEIGHT (B)		CORNER WEIGHT (C)		CORNER WEIGHT (D)		C.G.			HEIGHT
	LBS.	KG.	LBS.	KG.	LBS.	KG.	LBS.	KG.	LBS.	KG.	X	Y	Z	
50GC**04	468	212	128	58	117	53	106	48	116	53	35 1/2	22 1/4	18 3/8	[467]
50GC**05	510	231	140	64	128	58	116	53	127	58	35 1/2	22 1/4	18 3/8	[467]
50GC**06	555	252	152	69	135	61	126	57	141	64	35	22 1/2	19 1/2	[495]

* - STANDARD UNIT WEIGHT IS WITHOUT ELECTRIC HEAT AND WITHOUT PACKAGING.
 FOR OTHER OPTIONS AND ACCESSORIES REFER TO THE PRODUCT DATA CATALOG.



THIS DOCUMENT IS THE PROPERTY OF UTC CLIMATE CONTROLS & SECURITY AND IS DELIVERED UPON THE EXPRESS CONDITION THAT THE CONTENTS WILL NOT BE DISCLOSED OR USED WITHOUT WRITTEN CONSENT.

SUBMISSION OF THESE DRAWINGS OR DOCUMENTS DOES NOT CONSTITUTE PART PERFORMANCE OR ACCEPTANCE OF CONTRACT.

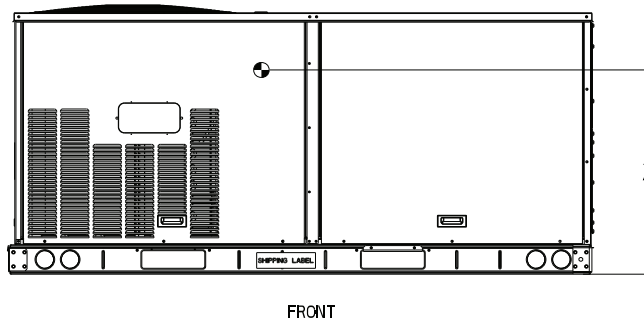
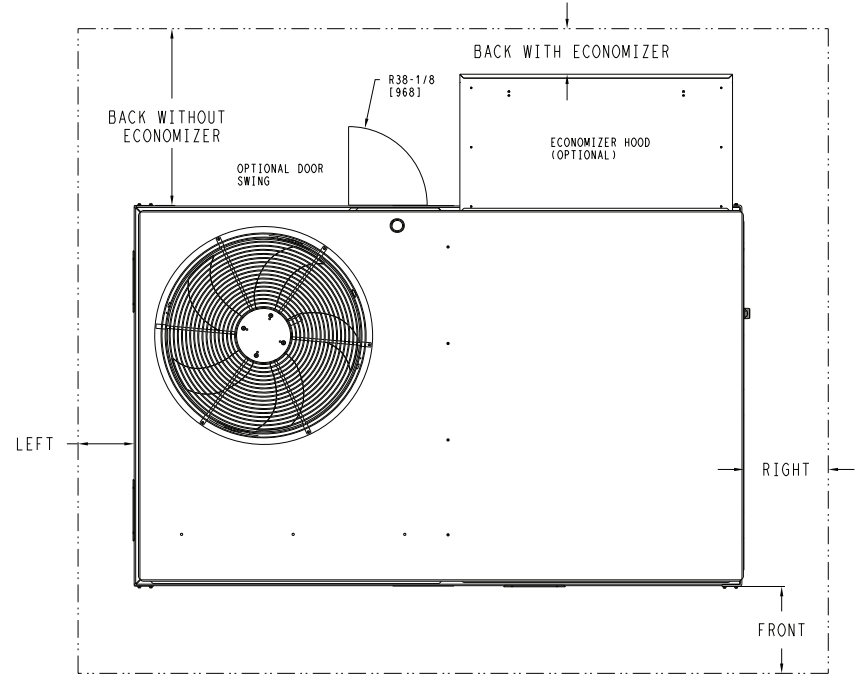
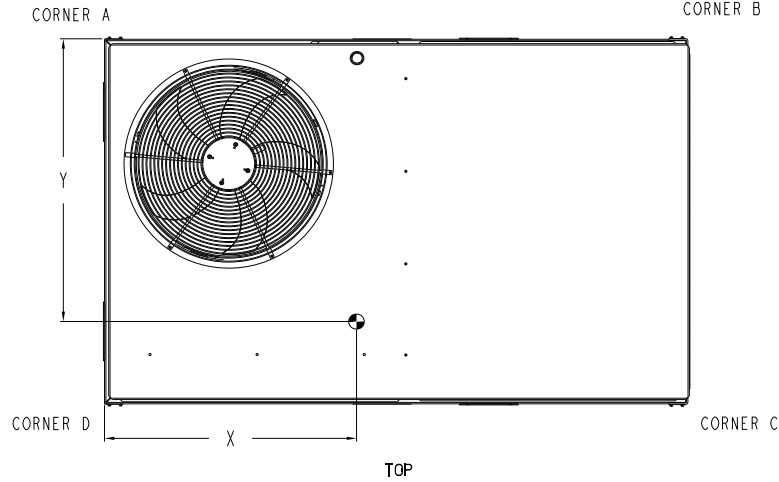

NOTE:

1. FOR ALL MINIMUM CLEARANCES LOCAL CODES OR JURISDICTIONS MAY PREVAIL.

SURFACE	CLEARANCE		OPERATING CLEARANCE
	SERVICE WITH: CONDUCTIVE BARRIER	SERVICE WITH: NONCONDUCTIVE BARRIER	
FRONT	48 [1219mm]	36 [914mm]	18 [457mm]
LEFT	48 [1219mm]	42 [1067mm]	18 [457mm]
BACK W/O HOOD	48 [1219mm]	42 [1067mm]	18 [457mm]
BACK W/ HOOD	36 [914mm]	36 [914mm]	18 [457mm]
RIGHT	36 [914mm]	36 [914mm]	18 [457mm]
TOP	72 [1829mm]	72 [1829mm]	72 [1829mm]

ITC CLASSIFICATION U.S. ECCN:NSR	SHEET 2 OF 3	DATE 03/21/19	SUPERCEDES 10/25/18	50GC 04-06 SINGLE PACKAGE ELECTRICAL COOLING WITH ELECTRIC HEAT	48TC003100	REV D
-------------------------------------	-----------------	------------------	------------------------	---	------------	----------



50GC-*04-06 Base Unit Dimensions (cont)



THIS DOCUMENT IS THE PROPERTY OF UTC CLIMATE, CONTROLS & SECURITY AND IS DELIVERED UPON THE EXPRESS CONDITION THAT THE CONTENTS WILL NOT BE DISCLOSED OR USED WITHOUT WRITTEN CONSENT.

SUBMISSION OF THESE DRAWINGS OR DOCUMENTS DOES NOT CONSTITUTE PART PERFORMANCE OR ACCEPTANCE OF CONTRACT.

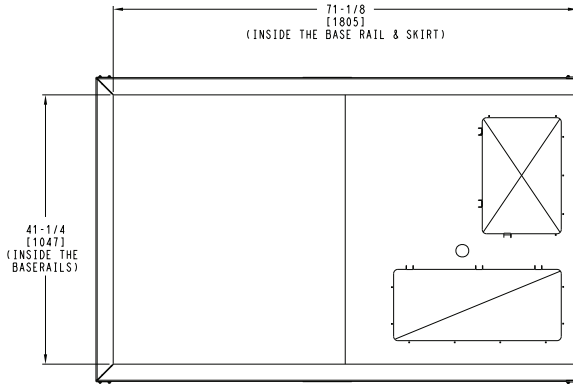
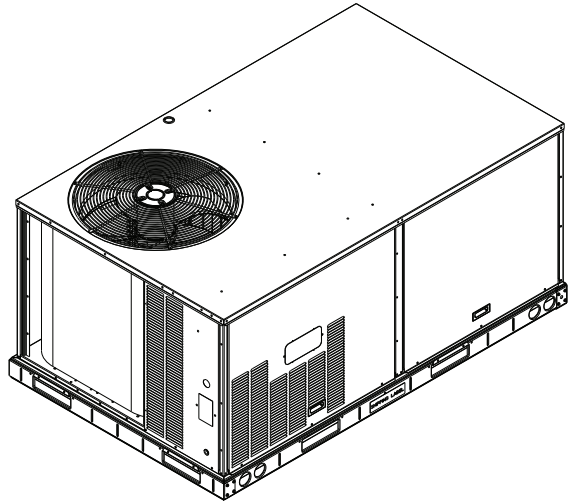

INSIDE BASERAIL DIMENSIONS
BOTTOM

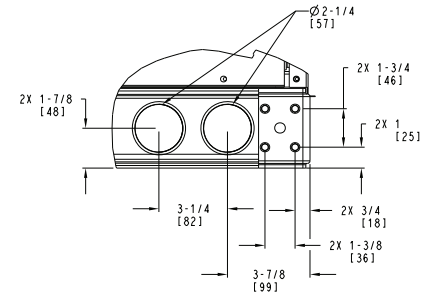

DETAIL C
TYP 4 PLCS

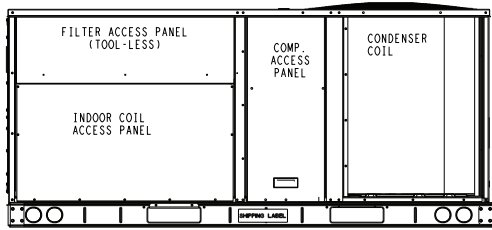

BACK

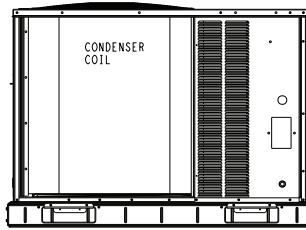

LEFT

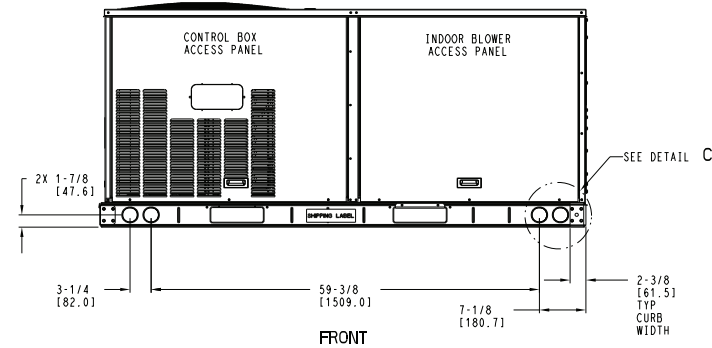

FRONT

ITC CLASSIFICATION U.S. ECCN:NSR	SHEET 3 OF 3	DATE 03/21/19	SUPERCEDES 10/25/18	50GC 04-06 SINGLE PACKAGE ELECTRICAL COOLING WITH ELECTRIC HEAT	48TC003100	REV D
-------------------------------------	-----------------	------------------	------------------------	---	------------	----------



Roof Curb Dimensions — 48/50GC 04-06

ROOF CURB ACCESSORY #	A
CRRFCURB001A01	14" [356]
CRRFCURB002A01	24" [610]

- NOTES:
1. ROOFCURB ACCESSORY IS SHIPPED DISASSEMBLED.
 2. INSULATED PANELS: 25.4 [1"] THK. POLYURETHANE FOAM, 44.5 [1-3/4"] # DENSITY.
 3. DIMENSIONS IN [] ARE IN MILLIMETERS.
 4. ROOFCURB: 18 GAGE STEEL.
 5. ATTACH DUCTWORK TO CURB. (FLANGES OF DUCT REST ON CURB).
 6. SERVICE CLEARANCE 4 FEET ON EACH SIDE.
 7. >>>> DIRECTION OF AIR FLOW.
 8. CONNECTOR PACKAGE CRBTMPWR001A01 IS FOR THRU-THE-CURB GAS TYPE PACKAGE CRBTMPWR003A01 IS FOR THRU-THE-BOTTOM TYPE GAS CONNECTIONS.

CONNECTOR PKG. ACC.	GAS CONNECTION TYPE	GAS FITTING	POWER WIRING FITTING	CONTROL WIRING FITTING	ACCESSORY CONVENIENCE OUTLET WIRING CONNECTOR
CRBTMPWR001A01	THRU THE CURB	3/4" [19] NPT	3/4" [19] NPT	1/2" [12.7] NPT	1/2" [12.7] NPT
CRBTMPWR003A01	THRU THE BOTTOM	1/2" [12.7] NPT			

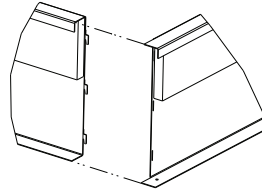
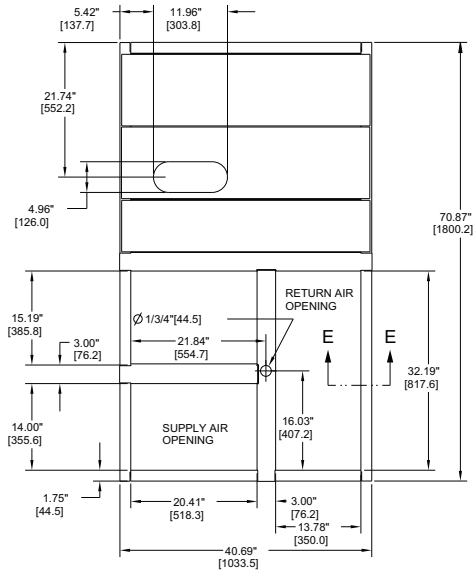

VIEW "B"
CORNER DETAIL

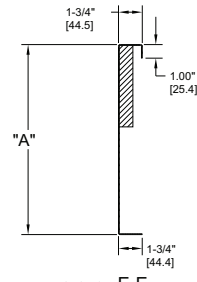

SECTION E-E
SCALE 0.250

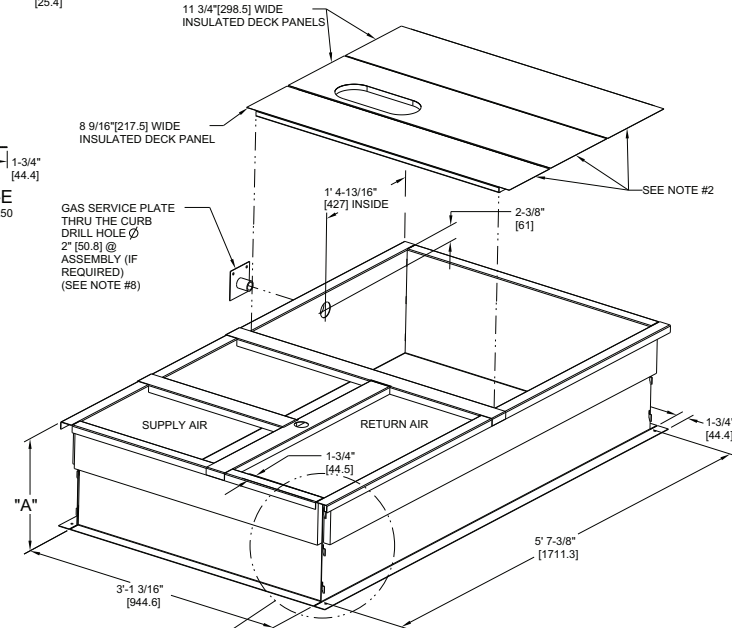

SEE VIEW "B"

CERTIFIED DRAWING

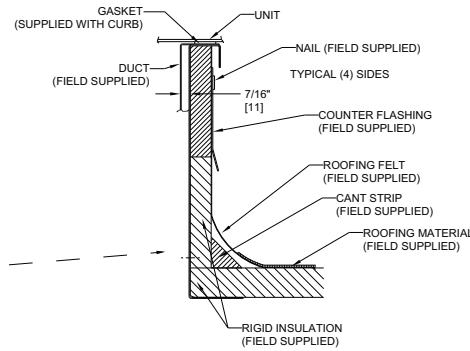
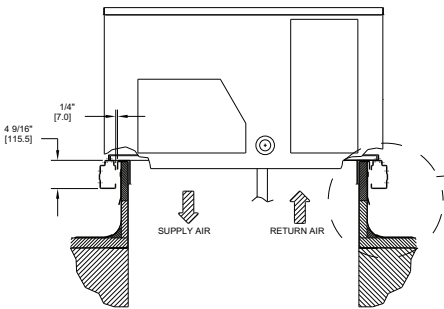

A	OVERALL DIM. 5'-7 3/8" WAS 5'-7 7/8"; 18GA MATERIAL WA 16 GA.; NAIL FIELD SUPPLIED WAS WITH CURB	04/22/13	MMC	-	-	1067898
REV	REVISION RECORD	DATE	BY	CHKD	APPD	ECN NO.

DRAWING RELEASE LEVEL: PRODUCTION		UNLESS OTHERWISE SPECIFIED DIMENSIONS ARE IN INCHES TOLERANCES ON:		TITLE	
THIRD ANGLE PROJECTION		1 DEC ±	2 DEC ±	3 DEC ±	ANG ° ±
MATERIAL	-	AUTHORIZATION NUMBER		1041738	
ENGINEERING REQUIREMENTS	T-005, Y-002	ENGINEERING	MANUFACTURING	TITLE: CURB ASY, ROOF	
WEIGHT	-	DRAFTER	CHECKER	SIZE	DRAWING NUMBER
SURFACE FINISH	-	MMC	06/17/11	D	48TC400427
MODEL (INTERNAL USE ONLY)	-	NEXT DRAWING		SCALE	DISTRIBUTION
PURCH	-	-		N/A	MMC



48/50GC**04 High Stage Cooling Capacities

48/50GC**04				AMBIENT TEMPERATURE (°F)												
				85			95			105			115			
				EA (db)			EA (db)			EA (db)			EA (db)			
				75	80	85	75	80	85	75	80	85	75	80	85	
900 cfm	EA (wb)	58	TC	29.8	29.8	33.0	27.7	27.7	31.7	25.8	25.8	29.7	23.8	23.8	27.5	
			SHC	25.1	29.0	33.0	23.7	27.7	31.7	22.0	25.8	29.7	20.2	23.8	27.5	
		62	TC	31.8	31.8	31.8	29.6	29.6	29.9	27.2	27.2	28.5	24.7	24.7	27.2	
			SHC	22.5	26.8	31.1	21.2	25.5	29.9	19.8	24.1	28.5	18.3	22.8	27.2	
		67	TC	35.7	35.7	35.7	33.4	33.4	33.4	30.8	30.8	30.8	28.2	28.2	28.2	
			SHC	18.7	22.9	27.1	17.3	21.5	25.8	15.8	20.1	24.5	14.3	18.7	23.1	
	72	TC	40.0	40.0	40.0	37.5	37.5	37.5	34.8	34.8	34.8	31.9	31.9	31.9		
		SHC	14.9	18.9	22.9	13.4	17.5	21.7	11.9	16.1	20.4	10.3	14.7	19.0		
	76	TC	—	43.7	43.7	—	41.1	41.1	—	38.2	38.2	—	35.2	35.2		
		SHC	—	15.5	20.5	—	14.1	19.1	—	12.8	17.7	—	11.3	15.1		
	1050 cfm	EA (wb)	58	TC	31.6	31.6	35.9	29.7	29.7	33.9	27.7	27.7	31.8	25.6	25.6	29.5
				SHC	27.2	31.6	35.9	25.5	29.7	33.9	23.7	27.7	31.8	21.7	25.6	29.5
62			TC	33.1	33.1	34.2	30.8	30.8	33.1	28.3	28.3	31.7	25.8	25.8	30.1	
			SHC	24.5	29.4	34.2	23.2	28.2	33.1	21.7	26.7	31.7	20.1	25.1	30.1	
67			TC	37.1	37.1	37.1	34.7	34.7	34.7	32.0	32.0	32.0	29.2	29.2	29.2	
			SHC	20.1	25.0	29.9	18.6	23.6	28.6	17.2	22.2	27.2	15.7	20.8	25.9	
72		TC	41.5	41.5	41.5	38.8	38.8	38.8	36.0	36.0	36.0	33.0	33.0	33		
		SHC	15.5	20.3	25.0	14.0	18.9	23.7	12.5	17.4	22.4	10.9	15.9	21.0		
76		TC	—	45.3	45.3	—	42.4	42.4	—	39.5	39.5	—	36.3	36.3		
		SHC	—	16.4	22.2	—	15.0	20.8	—	13.6	18.1	—	12.1	16.8		
1200 cfm		EA (wb)	58	TC	33.4	33.4	38.0	31.4	31.4	35.8	29.3	29.3	33.6	27.1	27.1	31.1
				SHC	28.8	33.4	38.0	27.0	31.4	35.8	25.1	29.3	33.6	23.0	27.1	31.1
	62		TC	34.2	34.2	37.4	31.8	31.8	35.9	29.5	29.5	34.6	27.1	27.1	32.5	
			SHC	26.4	31.9	37.4	24.9	30.4	35.9	23.5	29.1	34.6	21.7	27.1	32.5	
	67		TC	38.3	38.3	38.3	35.7	35.7	35.7	32.9	32.9	32.9	30.0	30.0	30.0	
			SHC	21.3	26.9	32.5	19.9	25.6	31.2	18.5	24.2	29.9	17.0	22.7	28.5	
	72	TC	42.7	42.7	42.7	39.9	39.9	39.9	37.0	37.0	37.0	33.9	33.9	33.9		
		SHC	16.1	21.5	27.0	14.6	20.1	25.7	13.0	18.7	24.3	11.4	17.1	22.8		
	76	TC	—	46.5	46.5	—	43.6	43.6	—	40.5	40.5	—	37.2	37.2		
		SHC	—	17.1	21.9	—	15.7	20.8	—	14.2	19.6	—	12.7	18.2		
	1350 cfm	EA (wb)	58	TC	34.9	34.9	39.7	32.9	32.9	37.4	30.7	30.7	35.1	28.3	28.3	32.5
				SHC	30.2	34.9	39.7	28.3	32.9	37.4	26.3	30.7	35.1	24.2	28.3	32.5
62			TC	36.2	36.2	38.4	34.0	34.0	36.4	30.6	30.6	36.5	28.4	28.4	34.0	
			SHC	27.4	32.9	38.4	25.7	31.0	36.4	24.7	30.6	36.5	22.8	28.4	34.0	
67			TC	39.2	39.2	39.2	36.5	36.5	36.5	33.7	33.7	33.7	30.7	30.7	31.1	
			SHC	22.6	28.8	35.1	21.1	27.4	33.7	19.7	26.1	32.5	18.2	24.6	31.1	
72		TC	43.6	43.6	43.6	40.8	40.8	40.8	37.7	37.7	37.7	34.6	34.6	34.6		
		SHC	16.6	22.7	28.8	15.1	21.3	27.5	13.5	19.8	26.1	11.9	18.3	24.6		
76		TC	—	47.5	47.5	—	44.5	44.5	—	41.3	41.3	—	37.9	37.9		
		SHC	—	17.8	23.5	—	16.3	22.2	—	14.8	20.9	—	13.2	19.4		
1500 cfm		EA (wb)	58	TC	36.2	36.2	41.1	34.2	34.2	38.9	31.9	31.9	36.4	29.4	29.4	33.7
				SHC	31.3	36.2	41.1	29.4	34.2	38.9	27.4	31.9	36.4	25.1	29.4	33.7
	62		TC	36.7	36.7	41.9	34.2	34.2	40.5	31.9	31.9	37.9	29.4	29.4	35.2	
			SHC	29.3	35.6	41.9	27.9	34.2	40.5	25.9	31.9	37.9	23.7	29.4	35.2	
	67		TC	39.9	39.9	39.9	37.1	37.1	37.1	34.2	34.2	34.9	31.1	31.1	33.3	
			SHC	23.8	30.7	37.6	22.3	29.3	36.2	20.8	27.9	34.9	19.2	26.3	33.3	
	72	TC	44.4	44.4	44.4	41.5	41.5	41.5	38.4	38.4	38.4	35.1	35.1	35.1		
		SHC	17.0	23.8	30.6	15.5	22.4	29.2	13.9	20.9	27.8	12.3	19.3	26.4		
	76	TC	—	48.3	48.3	—	45.2	45.2	—	41.9	41.9	—	38.5	38.5		
		SHC	—	18.3	24.8	—	16.8	23.5	—	15.3	22.1	—	13.7	20.6		

NOTE: See minimum-maximum airflow ratings on page 8.

LEGEND

—	— Do Not Operate
cfm	— Cubic Feet Per Minute (Supply Air)
EA (db)	— Entering Air Temperature (dry bulb)
EA (wb)	— Entering Air Temperature (wet bulb)
SHC	— Sensible Heat Capacity (1000 Btuh) Gross
TC	— Total Capacity (1000 Btuh) Gross

48/50GC**04 Low Stage Cooling Capacities

48/50GC**04				AMBIENT TEMPERATURE (°F)												
				85			95			105			115			
				EA (db)			EA (db)			EA (db)			EA (db)			
				75	80	85	75	80	85	75	80	85	75	80	85	
750 cfm	EA (wb)	58	TC	23.6	23.6	26.6	22.6	22.6	25.5	21.5	21.5	24.3	20.3	20.3	22.9	
			SHC	20.5	23.6	26.6	19.7	22.6	25.5	18.8	21.5	24.3	17.7	20.3	22.9	
		62	TC	24.4	24.4	25.8	23.1	23.1	25.3	21.7	21.7	24.7	20.5	20.5	23.5	
			SHC	18.8	22.3	25.8	18.2	21.8	25.3	17.6	21.2	24.7	16.6	20.0	23.5	
		67	TC	27.1	27.1	27.1	25.7	25.7	25.7	24.1	24.1	24.1	22.4	22.4	22.4	
			SHC	15.4	19.0	22.5	14.9	18.4	22.0	14.2	17.9	21.5	13.6	17.2	20.9	
	72	TC	30.0	30.0	30.0	28.4	28.4	28.4	26.7	26.7	26.7	24.9	24.9	24.9		
		SHC	12.0	15.5	18.9	11.4	14.9	18.4	10.7	14.3	17.8	10.0	13.6	17.2		
	76	TC	—	32.5	32.5	—	30.8	30.8	—	29.0	29.0	—	27.0	27.0		
		SHC	—	12.5	16.6	—	11.9	14.9	—	11.3	14.6	—	10.7	14.1		
	900 cfm	EA (wb)	58	TC	25.1	25.1	28.4	24.1	24.1	27.2	22.9	22.9	25.8	21.5	21.5	24.3
				SHC	21.9	25.1	28.4	21.0	24.1	27.2	19.9	22.9	25.8	18.8	21.5	24.3
62			TC	25.4	25.4	28.7	24.8	24.8	26.5	22.9	22.9	26.9	21.6	21.6	25.3	
			SHC	20.5	24.6	28.7	19.2	22.8	26.5	19.0	22.9	26.9	17.8	21.6	25.3	
67			TC	28.0	28.0	28.0	26.5	26.5	26.5	24.9	24.9	24.9	23.0	23.0	23.5	
			SHC	16.6	20.8	25.0	16.1	20.3	24.6	15.4	19.7	24.0	14.8	19.1	23.5	
72		TC	31.0	31.0	31.0	29.3	29.3	29.3	27.5	27.5	27.5	25.6	25.6	25.6		
		SHC	12.5	16.6	20.7	11.9	16.0	20.2	11.2	15.4	19.6	10.5	14.7	19.0		
76		TC	—	33.5	33.5	—	31.8	31.8	—	29.9	29.9	—	27.8	27.8		
		SHC	—	13.2	16.9	—	12.6	16.5	—	12.0	16.0	—	11.3	15.4		
1050 cfm		EA (wb)	58	TC	26.4	26.4	29.8	25.3	25.3	28.5	24.0	24.0	27.1	22.6	22.6	25.5
				SHC	23.0	26.4	29.8	22.1	25.3	28.5	20.9	24.0	27.1	19.6	22.6	25.5
	62		TC	26.6	26.6	30.6	25.3	25.3	29.7	24.0	24.0	28.2	22.6	22.6	26.5	
			SHC	21.8	26.2	30.6	21.0	25.3	29.7	19.9	24.0	28.2	18.7	22.6	26.5	
	67		TC	28.7	28.7	28.7	27.2	27.2	27.2	25.4	25.4	26.5	23.5	23.5	25.8	
			SHC	17.8	22.6	27.5	17.2	22.1	27.0	16.6	21.5	26.5	15.8	20.8	25.8	
	72	TC	31.7	31.7	31.7	30.0	30.0	30.0	28.1	28.1	28.1	26.1	26.1	26.1		
		SHC	12.9	17.7	22.5	12.3	17.1	22.0	11.6	16.5	21.4	10.9	15.8	20.8		
	76	TC	—	34.3	34.3	—	32.5	32.5	—	30.5	30.5	—	28.3	28.3		
		SHC	—	13.7	18.3	—	13.1	17.8	—	12.5	17.3	—	11.8	16.6		
	1200 cfm	EA (wb)	58	TC	27.5	27.5	31.0	26.3	26.3	29.7	24.9	24.9	28.1	23.4	23.4	26.4
				SHC	24.0	27.5	31.0	22.9	26.3	29.7	21.7	24.9	28.1	20.4	23.4	26.4
62			TC	27.5	27.5	32.2	26.3	26.3	30.8	25.0	25.0	29.2	23.4	23.4	27.4	
			SHC	22.8	27.5	32.2	21.8	26.3	30.8	20.7	25.0	29.2	19.4	23.4	27.4	
67			TC	29.3	29.3	29.8	27.6	27.6	29.3	25.8	25.8	28.7	23.9	23.9	27.9	
			SHC	18.9	24.3	29.8	18.2	23.7	29.3	17.6	23.1	28.7	16.8	22.3	27.9	
72		TC	32.3	32.3	32.3	30.5	30.5	30.5	28.6	28.6	28.6	26.5	26.5	26.5		
		SHC	13.3	18.8	24.2	12.7	18.2	23.6	12.0	17.6	23.1	11.3	16.9	22.5		
76		TC	—	34.9	34.9	—	33.0	33.0	—	30.9	30.9	—	28.7	28.7		
		SHC	—	14.2	19.5	—	13.6	19.0	—	13.0	18.4	—	12.3	17.8		
1350 cfm		EA (wb)	58	TC	28.4	28.4	32.0	27.1	27.1	30.6	25.7	25.7	29.0	24.1	24.1	27.2
				SHC	24.8	28.4	32.0	23.7	27.1	30.6	22.4	25.7	29.0	21.0	24.1	27.2
	62		TC	28.4	28.4	33.3	27.2	27.2	31.8	25.7	25.7	30.1	24.1	24.1	28.3	
			SHC	23.6	28.4	33.3	22.5	27.2	31.8	21.3	25.7	30.1	20.0	24.1	28.3	
	67		TC	29.6	29.6	31.8	28.0	28.0	31.5	26.2	26.2	30.6	24.2	24.2	29.8	
			SHC	19.7	25.8	31.8	19.2	25.3	31.5	18.5	24.6	30.6	17.7	23.7	29.8	
	72	TC	32.8	32.8	32.8	30.9	30.9	30.9	28.9	28.9	28.9	26.8	26.8	26.8		
		SHC	13.7	19.8	25.8	13.1	19.2	25.3	12.4	18.6	24.8	11.7	17.9	24.2		
	76	TC	—	35.4	35.4	—	33.4	33.4	—	31.3	31.3	—	29.0	29.0		
		SHC	—	14.7	20.6	—	14.1	20.1	—	13.4	19.5	—	12.7	18.9		

NOTE: See minimum-maximum airflow ratings on page 8.

LEGEND

—	— Do Not Operate
cfm	— Cubic Feet Per Minute (Supply Air)
EA (db)	— Entering Air Temperature (dry bulb)
EA (wb)	— Entering Air Temperature (wet bulb)
SHC	— Sensible Heat Capacity (1000 Btuh) Gross
TC	— Total Capacity (1000 Btuh) Gross

48/50GC*K04 — Unit with Humidi-MiZer® System in Subcooling Mode — Cooling Capacities

TEMP (°F) AIR ENTERING CONDENSER (Edb)		AIR ENTERING EVAPORATOR — SCFM/BF								
		900 / 0.01			1200 / 0.02			1500 / 0.04		
		Air Entering Evaporator — Ewb (°F)								
		72	67	62	72	67	62	72	67	62
75	TC	47.30	43.05	38.87	49.91	45.81	41.56	51.88	47.22	42.95
	SHC	25.33	28.76	32.11	27.32	32.24	37.10	28.89	34.79	40.92
	kW	2.60	2.51	2.44	2.92	2.83	2.72	3.38	3.27	3.15
85	TC	45.69	41.31	37.34	48.23	43.89	39.85	50.28	45.50	41.35
	SHC	23.99	27.23	30.77	25.85	30.55	35.58	27.51	33.28	39.55
	kW	2.88	2.78	2.70	3.19	3.10	3.02	3.66	3.54	3.42
95	TC	43.85	39.75	35.86	45.50	42.54	38.21	47.91	43.71	39.74
	SHC	22.42	25.91	29.51	23.37	26.59	34.15	25.33	31.70	37.82
	kW	3.17	3.08	2.99	3.45	3.41	3.31	3.96	3.85	3.71
105	TC	42.23	38.38	34.72	45.17	41.25	37.46	46.14	42.41	38.67
	SHC	21.08	24.79	28.60	23.29	28.36	33.64	23.76	30.62	37.32
	kW	3.49	3.40	3.32	3.83	3.73	3.62	4.29	4.17	4.03
115	TC	40.68	36.72	33.10	43.04	39.20	35.41	44.36	40.27	36.62
	SHC	19.79	23.35	27.21	21.37	26.52	31.81	22.11	28.66	35.48
	kW	3.82	3.73	3.65	4.16	4.05	3.94	4.61	4.49	4.35
125	TC	39.09	35.21	31.71	41.32	37.42	34.19	42.32	38.51	35.19
	SHC	18.46	22.08	26.05	19.82	24.95	30.82	20.17	27.06	32.95
	kW	4.16	4.07	3.99	4.51	4.39	4.28	4.95	4.83	4.69

48/50GC*K04 — Unit with Humidi-MiZer System in Hot Gas Reheat Mode — Cooling Capacities

TEMP (°F) AIR ENTERING CONDENSER (Edb)		AIR ENTERING EVAPORATOR — Ewb (°F)								
		75 Dry Bulb 62.5 Wet Bulb (50% Relative)			75 Dry Bulb 64 Wet Bulb (56% Relative)			75 Dry Bulb 65.3 Wet Bulb (60% Relative)		
		Air Entering Evaporator — cfm								
		900	1200	1500	900	1200	1500	900	1200	1500
80	TC	18.16	18.94	19.54	18.55	15.73	19.80	18.92	19.79	20.23
	SHC	10.03	11.42	12.58	9.04	1.14	10.56	8.28	9.04	9.05
	kW	2.50	2.84	3.26	2.63	3.23	3.42	2.74	3.02	3.48
75	TC	15.90	16.31	16.77	16.18	16.94	17.39	16.69	17.33	17.89
	SHC	6.65	7.39	8.13	5.45	6.06	6.14	4.71	4.85	4.53
	kW	2.68	3.05	3.50	2.79	3.09	3.53	2.84	3.14	3.57
70	TC	14.07	14.69	15.08	14.54	15.00	15.61	15.05	15.62	16.30
	SHC	4.05	4.84	5.37	2.81	2.90	2.96	1.94	1.69	1.22
	kW	2.80	3.11	3.56	2.87	3.21	3.59	2.87	3.19	3.58
60	TC	21.22	22.32	23.08	22.09	20.29	21.73	21.70	20.81	23.54
	SHC	15.97	18.60	20.93	15.62	16.49	3.03	14.54	3.30	17.71
	kW	2.30	2.56	2.94	2.32	2.72	2.88	2.52	2.66	3.15
50	TC	19.14	20.17	21.37	19.74	21.24	21.99	20.27	21.83	21.73
	SHC	8.45	9.72	11.19	7.04	4.44	8.63	5.82	6.60	5.71
	kW	2.69	3.01	3.35	2.74	2.99	3.39	2.78	2.99	3.54
40	TC	21.96	23.29	23.84	22.89	24.34	23.61	23.53	24.99	24.59
	SHC	11.94	13.47	15.84	10.97	12.06	11.16	9.92	10.62	9.49
	kW	2.48	2.70	3.14	2.44	2.68	3.33	2.47	2.71	3.30

LEGEND

- Edb** — Entering Dry Bulb
- Ewb** — Entering Wet Bulb
- kW** — Compressor Power Input
- SCFM/BF** — Standard Cubic Feet per Minute/Bypass Factor
- SHC** — Sensible Heat Capacity (1000 Btuh) Gross
- TC** — Total Capacity (1000 Btuh) Gross

48/50GC**05 High Stage Cooling Capacities

48/50GC**05				AMBIENT TEMPERATURE (°F)												
				85			95			105			115			
				EA (db)			EA (db)			EA (db)			EA (db)			
				75	80	85	75	80	85	75	80	85	75	80	85	
1200 cfm	EA (wb)	58	TC	42.9	42.9	48.6	40.8	40.8	46.3	38.6	38.6	43.8	36.2	36.2	41.2	
			SHC	37.3	42.9	48.6	35.3	40.8	46.3	33.3	38.6	43.8	31.2	36.2	41.2	
		62	TC	45.0	45.0	45.2	42.7	42.7	44.8	39.9	39.9	43.2	36.9	36.9	41.6	
			SHC	33.0	39.1	45.2	32.2	38.5	44.8	30.6	36.9	43.2	29.0	35.3	41.6	
		67	TC	49.9	49.9	49.9	47.2	47.2	47.2	44.3	44.3	44.3	41.1	41.1	41.1	
			SHC	27.2	33.2	39.3	25.8	32.0	38.2	24.5	30.7	37.0	22.9	29.2	35.5	
	72	TC	55.0	55.0	55.0	52.2	52.2	52.2	49.1	49.1	49.1	45.7	45.7	45.7		
		SHC	21.1	27.0	32.8	19.7	25.8	31.8	18.2	24.4	30.6	16.6	22.8	29.1		
	76	TC	—	59.6	59.6	—	56.5	56.5	—	53.1	53.1	—	49.4	49.4		
		SHC	—	21.9	28.5	—	20.7	27.3	—	19.2	24.6	—	17.7	23.5		
	1400 cfm	EA (wb)	58	TC	45.6	45.6	51.6	43.3	43.3	49.1	40.9	40.9	46.4	38.3	38.3	43.6
				SHC	39.6	45.6	51.6	37.5	43.3	49.1	35.4	40.9	46.4	33.1	38.3	43.6
62			TC	46.9	46.9	51.2	44.1	44.1	49.6	42.0	42.0	45.1	38.6	38.6	44.8	
			SHC	36.6	43.9	51.2	35.0	42.3	49.6	32.1	38.6	45.1	31.1	37.9	44.8	
67			TC	51.7	51.7	51.7	48.8	48.8	48.8	45.6	45.6	45.6	42.3	42.3	42.3	
			SHC	29.1	36.2	43.3	27.8	35.1	42.4	26.3	33.6	40.9	24.7	32.0	39.3	
72		TC	56.9	56.9	56.9	53.8	53.8	53.8	50.5	50.5	50.5	46.9	46.9	46.9		
		SHC	21.9	28.8	35.7	20.5	27.5	34.6	19.0	26.1	33.3	17.3	24.5	31.8		
76		TC	—	61.4	61.4	—	58.1	58.1	—	54.5	54.5	—	50.7	50.7		
		SHC	—	23.0	29.0	—	21.6	28.1	—	20.1	26.9	—	18.5	25.5		
1600 cfm		EA (wb)	58	TC	47.8	47.8	54.0	45.4	45.4	51.4	42.8	42.8	48.6	40.1	40.1	45.6
				SHC	41.5	47.8	54.0	39.4	45.4	51.4	37.1	42.8	48.6	34.7	40.1	45.6
	62		TC	48.2	48.2	55.5	46.4	46.4	50.2	42.9	42.9	50.6	40.2	40.2	47.5	
			SHC	39.2	47.3	55.5	35.9	43.0	50.2	35.2	42.9	50.6	32.9	40.2	47.5	
	67		TC	53.0	53.0	53.0	49.9	49.9	49.9	46.6	46.6	46.6	43.2	43.2	43.2	
			SHC	30.9	39.1	47.2	29.6	37.8	46.1	28.0	36.3	44.6	26.4	34.7	43.0	
	72	TC	58.3	58.3	58.3	55.0	55.0	55.0	51.5	51.5	51.5	47.8	47.8	47.8		
		SHC	22.6	30.5	38.5	21.1	29.3	37.4	19.6	27.7	35.9	17.9	26.1	34.3		
	76	TC	—	62.8	62.8	—	59.3	59.3	—	55.6	55.6	—	51.7	51.7		
		SHC	—	23.8	31.2	—	22.3	30.0	—	20.8	28.7	—	19.2	27.2		
	1800 cfm	EA (wb)	58	TC	49.7	49.7	56.1	47.1	47.1	53.4	44.5	44.5	50.4	41.6	41.6	47.3
				SHC	43.2	49.7	56.1	40.9	47.1	53.4	38.5	44.5	50.4	36.0	41.6	47.3
62			TC	50.5	50.5	55.2	47.2	47.2	55.5	44.5	44.5	52.5	41.7	41.7	49.2	
			SHC	39.5	47.3	55.2	38.9	47.2	55.5	36.6	44.5	52.5	34.2	41.7	49.2	
67			TC	54.0	54.0	54.0	50.8	50.8	50.8	47.4	47.4	48.2	43.9	43.9	46.6	
			SHC	32.7	42.0	51.2	31.3	40.5	49.8	29.7	38.9	48.2	28.1	37.3	46.6	
72		TC	59.3	59.3	59.3	55.9	55.9	55.9	52.3	52.3	52.3	48.5	48.5	48.5		
		SHC	23.1	32.1	41.0	21.7	30.8	39.9	20.1	29.2	38.4	18.4	27.6	36.8		
76		TC	—	63.9	63.9	—	60.3	60.3	—	56.5	56.5	—	52.5	52.5		
		SHC	—	24.4	33.0	—	23.0	31.7	—	21.5	30.3	—	19.8	28.8		
2000 cfm		EA (wb)	58	TC	51.3	51.3	57.9	48.7	48.7	55.1	45.9	45.9	52.0	42.9	42.9	48.7
				SHC	44.6	51.3	57.9	42.3	48.7	55.1	39.8	45.9	52.0	37.1	42.9	48.7
	62		TC	51.3	51.3	60.2	48.7	48.7	57.3	45.9	45.9	54.1	43.0	43.0	50.7	
			SHC	42.4	51.3	60.2	40.2	48.7	57.3	37.8	45.9	54.1	35.2	43.0	50.7	
	67		TC	54.8	54.8	54.8	51.5	51.5	53.3	48.1	48.1	51.7	44.4	44.4	50.1	
			SHC	34.4	44.6	54.8	32.9	43.1	53.3	31.3	41.5	51.7	29.7	39.9	50.1	
	72	TC	60.2	60.2	60.2	56.7	56.7	56.7	53.0	53.0	53.0	49.1	49.1	49.1		
		SHC	23.7	33.6	43.6	22.2	32.2	42.3	20.6	30.7	40.8	18.9	29.0	39.2		
	76	TC	—	64.8	64.8	—	61.1	61.1	—	57.2	57.2	—	53.1	53.1		
		SHC	—	25.0	34.6	—	23.5	33.3	—	22.0	31.8	—	20.3	30.2		

NOTE: See minimum-maximum airflow ratings on page 8.

LEGEND

—	— Do Not Operate
cfm	— Cubic Feet Per Minute (Supply Air)
EA (db)	— Entering Air Temperature (dry bulb)
EA (wb)	— Entering Air Temperature (wet bulb)
SHC	— Sensible Heat Capacity (1000 Btuh) Gross
TC	— Total Capacity (1000 Btuh) Gross

48/50GC**05 Low Stage Cooling Capacities

48/50GC**05				AMBIENT TEMPERATURE (°F)												
				85			95			105			115			
				EA (db)			EA (db)			EA (db)			EA (db)			
				75	80	85	75	80	85	75	80	85	75	80	85	
1000 cfm	EA (wb)	58	TC	27.0	27.0	30.4	25.7	25.7	29.0	24.3	24.3	27.4	22.8	22.8	25.7	
			SHC	23.5	27.0	30.4	22.4	25.7	29.0	21.2	24.3	27.4	19.8	22.8	25.7	
		62	TC	27.0	27.0	31.6	25.7	25.7	30.1	24.3	24.3	28.5	22.8	22.8	26.7	
			SHC	22.4	27.0	31.6	21.3	25.7	30.1	20.2	24.3	28.5	18.9	22.8	26.7	
		67	TC	29.2	29.2	29.2	27.5	27.5	27.8	25.7	25.7	27.0	23.7	23.7	26.2	
			SHC	18.3	23.4	28.5	17.6	22.7	27.8	16.9	22.0	27.0	16.1	21.1	26.2	
	72	TC	32.4	32.4	32.4	30.5	30.5	30.5	28.6	28.6	28.6	26.4	26.4	26.4		
		SHC	13.3	18.4	23.5	12.6	17.7	22.9	11.9	17.0	22.1	11.1	16.2	21.3		
	76	TC	—	35.0	35.0	—	33.1	33.1	—	31.0	31.0	—	28.7	28.7		
		SHC	—	14.4	19.5	—	13.7	18.9	—	12.9	18.1	—	12.2	17.3		
	1200 cfm	EA (wb)	58	TC	28.5	28.5	32.1	27.1	27.1	30.6	25.6	25.6	28.9	23.9	23.9	27.0
				SHC	24.8	28.5	32.1	23.6	27.1	30.6	22.3	25.6	28.9	20.9	23.9	27.0
62			TC	28.5	28.5	33.4	27.1	27.1	31.8	25.6	25.6	30.0	24.0	24.0	28.1	
			SHC	23.6	28.5	33.4	22.5	27.1	31.8	21.2	25.6	30.0	19.8	24.0	28.1	
67			TC	30.0	30.0	31.9	28.2	28.2	31.1	26.3	26.3	30.3	24.6	24.6	27.0	
			SHC	19.9	25.9	31.9	19.2	25.1	31.1	18.4	24.3	30.3	16.6	21.8	27.0	
72		TC	33.1	33.1	33.1	31.2	31.2	31.2	29.2	29.2	29.2	26.9	26.9	26.9		
		SHC	13.9	19.9	26.0	13.2	19.2	25.3	12.5	18.5	24.6	11.7	17.7	23.8		
76		TC	—	35.8	35.8	—	33.8	33.8	—	31.6	31.6	—	29.3	29.3		
		SHC	—	15.1	21.2	—	14.4	20.5	—	13.7	19.8	—	12.9	19.0		
1400 cfm		EA (wb)	58	TC	29.7	29.7	33.5	28.2	28.2	31.8	26.6	26.6	30.0	24.9	24.9	28.1
				SHC	25.9	29.7	33.5	24.6	28.2	31.8	23.2	26.6	30.0	21.7	24.9	28.1
	62		TC	29.7	29.7	34.8	28.2	28.2	33.1	26.6	26.6	31.2	24.9	24.9	29.1	
			SHC	24.6	29.7	34.8	23.4	28.2	33.1	22.1	26.6	31.2	20.6	24.9	29.1	
	67		TC	30.5	30.5	35.0	28.7	28.7	34.2	27.1	27.1	30.6	25.3	25.3	28.3	
			SHC	21.3	28.1	35.0	20.6	27.4	34.2	18.7	24.6	30.6	17.3	22.8	28.3	
	72	TC	33.7	33.7	33.7	31.7	31.7	31.7	29.6	29.6	29.6	27.3	27.3	27.3		
		SHC	14.4	21.4	28.3	13.7	20.7	27.6	13.0	19.9	26.9	12.2	19.1	26.1		
	76	TC	—	36.4	36.4	—	34.3	34.3	—	32.1	32.1	—	29.7	29.7		
		SHC	—	15.7	22.8	—	15.0	22.1	—	14.3	21.3	—	13.5	20.5		
	1600 cfm	EA (wb)	58	TC	30.7	30.7	34.6	29.1	29.1	32.8	27.4	27.4	31.0	25.6	25.6	28.9
				SHC	26.7	30.7	34.6	25.4	29.1	32.8	23.9	27.4	31.0	22.3	25.6	28.9
62			TC	30.7	30.7	35.9	29.1	29.1	34.1	27.5	27.5	32.2	25.6	25.6	30.0	
			SHC	25.5	30.7	35.9	24.2	29.1	34.1	22.8	27.5	32.2	21.2	25.6	30.0	
67			TC	31.0	31.0	37.8	29.6	29.6	33.0	27.6	27.6	33.6	25.6	25.6	32.2	
			SHC	22.6	30.2	37.8	20.2	26.6	33.0	20.1	26.9	33.6	19.1	25.6	32.2	
72		TC	34.1	34.1	34.1	32.1	32.1	32.1	29.9	29.9	29.9	27.6	27.6	28.3		
		SHC	14.9	22.7	30.6	14.2	22.0	29.9	13.5	21.3	29.1	12.7	20.5	28.3		
76		TC	—	36.9	36.9	—	34.7	34.7	—	32.4	32.4	—	30.0	30.0		
		SHC	—	16.3	24.2	—	15.6	23.5	—	14.8	22.7	—	14.0	21.9		
1800 cfm		EA (wb)	58	TC	31.5	31.5	35.5	29.9	29.9	33.7	28.1	28.1	31.7	26.2	26.2	29.6
				SHC	27.5	31.5	35.5	26.1	29.9	33.7	24.5	28.1	31.7	22.9	26.2	29.6
	62		TC	31.5	31.5	36.9	29.9	29.9	35.0	28.1	28.1	33.0	26.2	26.2	30.7	
			SHC	26.1	31.5	36.9	24.8	29.9	35.0	23.3	28.1	33.0	21.7	26.2	30.7	
	67		TC	31.9	31.9	37.1	30.1	30.1	35.9	28.2	28.2	35.4	26.3	26.3	33.0	
			SHC	22.5	29.8	37.1	21.6	28.8	35.9	21.0	28.2	35.4	19.5	26.3	33.0	
	72	TC	34.4	34.4	34.4	32.4	32.4	32.4	30.2	30.2	31.3	27.8	27.8	30.5		
		SHC	15.3	24.0	32.7	14.6	23.3	32.0	13.9	22.6	31.3	13.2	21.8	30.5		
	76	TC	—	37.2	37.2	—	35.0	35.0	—	32.7	32.7	—	30.2	30.2		
		SHC	—	16.7	25.5	—	16.0	24.8	—	15.3	24.0	—	14.5	23.2		

NOTE: See minimum-maximum airflow ratings on page 8.

LEGEND

- Do Not Operate
- cfm — Cubic Feet Per Minute (Supply Air)
- EA (db) — Entering Air Temperature (dry bulb)
- EA (wb) — Entering Air Temperature (wet bulb)
- SHC — Sensible Heat Capacity (1000 Btuh) Gross
- TC — Total Capacity (1000 Btuh) Gross

48/50GC*K05 — Unit with Humidi-MiZer System in Subcooling Mode — Cooling Capacities

TEMP (°F) AIR ENTERING CONDENSER (Edb)		AIR ENTERING EVAPORATOR — SCFM/BF								
		1200 / 0.04			1600 / 0.07			2000 / 0.10		
		Air Entering Evaporator — Ewb (°F)								
		72	67	62	72	67	62	72	67	62
75	TC	38.00	39.70	43.31	43.37	45.88	43.25	47.20	44.91	37.63
	SHC	21.82	25.72	34.19	35.87	27.32	18.69	19.45	24.12	27.37
	kW	3.64	3.61	3.57	4.40	4.25	4.09	5.14	5.07	4.89
85	TC	46.72	39.86	32.37	26.43	33.39	40.66	35.15	26.67	18.42
	SHC	19.44	22.28	24.79	20.96	15.48	10.27	6.71	8.33	10.65
	kW	4.87	4.75	4.56	5.74	5.40	5.12	6.50	6.26	5.99
95	TC	38.67	38.73	38.97	46.27	44.72	41.32	46.89	47.97	42.62
	SHC	23.41	26.38	31.56	41.94	25.83	19.32	21.43	29.30	36.07
	kW	3.86	3.81	3.76	4.58	4.50	4.32	5.38	5.31	5.19
105	TC	49.17	45.18	37.85	32.39	39.47	46.16	40.02	31.96	23.66
	SHC	23.37	29.52	33.96	30.59	23.42	15.98	11.38	15.48	19.56
	kW	5.10	5.04	4.84	6.00	5.73	5.40	6.85	6.57	6.29
115	TC	39.82	39.51	43.61	46.81	43.87	41.25	47.48	48.48	46.81
	SHC	25.15	27.86	37.02	43.47	29.26	20.60	23.38	31.58	43.95
	kW	4.12	4.05	3.96	4.88	4.73	4.55	5.65	5.57	5.41
125	TC	50.70	48.95	42.25	37.19	43.24	48.91	44.27	35.61	28.16
	SHC	26.40	35.57	41.60	38.25	29.59	19.81	16.07	21.45	25.87
	kW	5.32	5.24	5.08	6.22	6.02	5.64	7.12	6.84	6.51

48/50GC*K05 — Unit with Humidi-MiZer System in Hot Gas Reheat Mode — Cooling Capacities

TEMP (°F) AIR ENTERING CONDENSER (Edb)		AIR ENTERING EVAPORATOR — Ewb (°F)								
		75 Dry Bulb 62.5 Wet Bulb (50% Relative)			75 Dry Bulb 64 Wet Bulb (56% Relative)			75 Dry Bulb 65.3 Wet Bulb (60% Relative)		
		Air Entering Evaporator — cfm								
		1200	1600	2000	1200	1600	2000	1200	1600	2000
80	TC	19.74	21.01	21.80	20.54	18.34	22.60	21.27	22.52	23.27
	SHC	6.52	9.56	12.58	4.88	-1.55	9.44	3.53	5.28	6.74
	kW	3.23	3.51	3.93	3.26	3.79	3.97	3.29	3.57	4.00
75	TC	17.95	19.09	19.84	18.64	19.86	20.60	19.28	20.48	21.26
	SHC	3.59	6.18	8.85	1.71	3.63	5.37	0.16	1.46	2.49
	kW	3.32	3.60	4.02	3.36	3.64	4.06	3.40	3.67	4.09
70	TC	16.24	17.37	18.10	16.93	18.06	18.78	17.50	18.66	19.43
	SHC	1.11	3.54	6.06	-0.98	0.61	2.14	-2.74	-1.82	-1.08
	kW	3.45	3.72	4.15	3.48	3.75	4.18	3.50	3.78	4.20
60	TC	23.03	24.36	25.17	23.97	23.12	24.31	24.58	24.02	26.61
	SHC	12.73	16.77	20.82	11.40	13.99	1.73	10.30	0.02	15.43
	kW	3.06	3.34	3.75	3.09	3.38	3.62	3.11	3.26	3.82
50	TC	21.96	23.26	24.08	22.66	23.92	24.79	23.28	24.58	25.25
	SHC	6.15	8.87	11.66	3.79	1.86	7.56	1.73	2.91	3.89
	kW	3.28	3.61	4.07	3.33	3.71	4.12	3.38	3.71	4.17
40	TC	24.95	26.18	26.99	25.63	26.96	27.58	26.33	27.65	28.27
	SHC	9.83	12.44	15.51	7.56	9.43	11.17	5.65	6.86	7.83
	kW	3.06	3.38	3.84	3.11	3.44	3.89	3.15	3.48	3.94

LEGEND

- Edb — Entering Dry Bulb
- Ewb — Entering Wet Bulb
- kW — Compressor Power Input
- SCFM/BF — Standard Cubic Feet per Minute/Bypass Factor
- SHC — Sensible Heat Capacity (1000 Btuh) Gross
- TC — Total Capacity (1000 Btuh) Gross



48/50GC**06 High Stage Cooling Capacities

48/50GC**06				AMBIENT TEMPERATURE (°F)												
				85			95			105			115			
				EA (db)			EA (db)			EA (db)			EA (db)			
				75	80	85	75	80	85	75	80	85	75	80	85	
1500 cfm	EA (wb)	58	TC	53.3	53.3	60.3	50.7	50.7	57.5	48.0	48.0	54.5	45.2	45.2	51.3	
			SHC	46.3	53.3	60.3	44.0	50.7	57.5	41.5	48.0	54.5	39.0	45.2	51.3	
		62	TC	56.4	56.4	57.3	53.1	53.1	55.4	49.7	49.7	53.5	46.2	46.2	51.5	
			SHC	41.8	49.6	57.3	40.0	47.7	55.4	38.1	45.8	53.5	36.1	43.8	51.5	
		67	TC	62.2	62.2	62.2	58.7	58.7	58.7	55.0	55.0	55.0	51.2	51.2	51.2	
			SHC	34.3	42.1	49.8	32.5	40.2	48.0	30.6	38.4	46.1	28.7	36.4	44.2	
	72	TC	68.5	68.5	68.5	64.7	64.7	64.7	60.7	60.7	60.7	56.6	56.6	56.6		
		SHC	26.6	34.5	42.3	24.8	32.6	40.5	22.9	30.7	38.5	21.0	28.8	36.6		
	76	TC	—	73.8	73.8	—	69.8	69.8	—	65.5	65.5	—	61.1	61.1		
		SHC	—	28.3	36.5	—	26.5	34.7	—	24.6	32.7	—	22.7	30.7		
	1750 cfm	EA (wb)	58	TC	56.5	56.5	63.9	53.7	53.7	60.8	50.8	50.8	57.6	47.7	47.7	54.2
				SHC	49.1	56.5	63.9	46.6	53.7	60.8	44.0	50.8	57.6	41.2	47.7	54.2
62			TC	58.3	58.3	63.0	54.9	54.9	61.0	51.4	51.4	58.9	48.1	48.1	55.5	
			SHC	45.3	54.1	63.0	43.3	52.2	61.0	41.3	50.1	58.9	38.7	47.1	55.5	
67			TC	64.1	64.1	64.1	60.5	60.5	60.5	56.6	56.6	56.6	52.6	52.6	52.6	
			SHC	36.5	45.5	54.4	34.7	43.6	52.6	32.8	41.7	50.6	30.8	39.7	48.6	
72		TC	70.5	70.5	70.5	66.5	66.5	66.5	62.4	62.4	62.4	58.0	58.0	58.0		
		SHC	27.6	36.6	45.6	25.7	34.7	43.7	23.8	32.8	41.7	21.9	30.8	39.7		
76		TC	—	75.9	75.9	—	71.6	71.6	—	67.2	67.2	—	62.6	62.6		
		SHC	—	29.4	38.8	—	27.5	36.8	—	25.6	34.8	—	23.6	32.8		
2000 cfm		EA (wb)	58	TC	59.1	59.1	66.8	56.2	56.2	63.5	53.1	53.1	60.1	49.8	49.8	56.5
				SHC	51.4	59.1	66.8	48.8	56.2	63.5	46.0	53.1	60.1	43.1	49.8	56.5
	62		TC	59.9	59.9	68.2	56.9	56.9	63.8	54.0	54.0	59.1	49.9	49.9	58.8	
			SHC	48.4	58.3	68.2	45.3	54.5	63.8	42.0	50.5	59.1	40.9	49.9	58.8	
	67		TC	65.6	65.6	65.6	61.8	61.8	61.8	57.8	57.8	57.8	53.7	53.7	53.7	
			SHC	38.6	48.7	58.8	36.7	46.8	56.9	34.8	44.9	54.9	32.8	42.9	52.9	
	72	TC	72.1	72.1	72.1	67.9	67.9	67.9	63.6	63.6	63.6	59.2	59.2	59.2		
		SHC	28.4	38.5	48.6	26.5	36.6	46.7	24.5	34.6	44.7	22.6	32.6	42.7		
	76	TC	—	77.5	77.5	—	73.1	73.1	—	68.5	68.5	—	63.7	63.7		
		SHC	—	30.3	40.7	—	28.4	38.8	—	26.4	36.7	—	24.4	34.6		
	2250 cfm	EA (wb)	58	TC	61.4	61.4	69.3	58.3	58.3	65.9	55.0	55.0	62.3	51.6	51.6	58.5
				SHC	53.4	61.4	69.3	50.6	58.3	65.9	47.7	55.0	62.3	44.7	51.6	58.5
62			TC	61.4	61.4	72.0	58.3	58.3	68.5	55.1	55.1	64.8	51.6	51.6	60.9	
			SHC	50.8	61.4	72.0	48.1	58.3	68.5	45.3	55.1	64.8	42.4	51.6	60.9	
67			TC	66.8	66.8	66.8	62.9	62.9	62.9	58.8	58.8	59.1	54.5	54.5	57.0	
			SHC	40.6	51.8	63.0	38.7	49.9	61.1	36.7	47.9	59.1	34.7	45.9	57.0	
72		TC	73.3	73.3	73.3	69.1	69.1	69.1	64.6	64.6	64.6	60.0	60.0	60.0		
		SHC	29.0	40.2	51.5	27.1	38.3	49.5	25.1	36.3	47.5	23.1	34.3	45.4		
76		TC	—	78.7	78.7	—	74.2	74.2	—	69.5	69.5	—	64.6	64.6		
		SHC	—	31.0	42.5	—	29.1	40.5	—	27.1	38.4	—	25.0	36.3		
2500 cfm		EA (wb)	58	TC	63.3	63.3	71.5	60.1	60.1	67.9	56.7	56.7	64.1	53.1	53.1	60.2
				SHC	55.1	63.3	71.5	52.2	60.1	67.9	49.2	56.7	64.1	46.0	53.1	60.2
	62		TC	63.3	63.3	74.3	60.1	60.1	70.6	56.7	56.7	66.7	53.1	53.1	62.6	
			SHC	52.4	63.3	74.3	49.6	60.1	70.6	46.7	56.7	66.7	43.7	53.1	62.6	
	67		TC	67.8	67.8	67.8	63.7	63.7	65.1	59.5	59.5	63.0	55.2	55.2	60.9	
			SHC	42.4	54.7	67.0	40.5	52.8	65.1	38.5	50.8	63.0	36.5	48.7	60.9	
	72	TC	74.3	74.3	74.3	70.0	70.0	70.0	65.4	65.4	65.4	60.7	60.7	60.7		
		SHC	29.5	41.8	54.1	27.6	39.9	52.2	25.6	37.9	50.1	23.6	35.8	48.0		
	76	TC	—	79.7	79.7	—	75.1	75.1	—	70.3	70.3	—	65.3	65.3		
		SHC	—	31.5	44.0	—	29.6	42.0	—	27.6	39.9	—	25.5	37.7		

NOTE: See minimum-maximum airflow ratings on page 8.

LEGEND

- Do Not Operate
- cfm — Cubic Feet Per Minute (Supply Air)
- EA (db) — Entering Air Temperature (dry bulb)
- EA (wb) — Entering Air Temperature (wet bulb)
- SHC — Sensible Heat Capacity (1000 Btuh) Gross
- TC — Total Capacity (1000 Btuh) Gross

48/50GC**06 Low Stage Cooling Capacities

48/50GC**06				AMBIENT TEMPERATURE (°F)												
				85			95			105			115			
				EA (db)			EA (db)			EA (db)			EA (db)			
				75	80	85	75	80	85	75	80	85	75	80	85	
1250 cfm	EA (wb)	58	TC	41.4	41.4	46.5	39.9	39.9	44.7	38.1	38.1	42.7	36.1	36.1	40.4	
			SHC	36.3	41.4	46.5	35.0	39.9	44.7	33.5	38.1	42.7	31.8	36.1	40.4	
		62	TC	42.3	42.3	46.5	40.3	40.3	45.6	38.2	38.2	44.4	36.1	36.1	41.9	
			SHC	33.8	40.2	46.5	33.1	39.3	45.6	32.0	38.2	44.4	30.4	36.1	41.9	
		67	TC	46.2	46.2	46.2	44.1	44.1	44.1	41.6	41.6	41.6	38.9	38.9	38.9	
			SHC	27.5	33.9	40.3	26.8	33.2	39.6	26.0	32.4	38.8	25.1	31.5	37.9	
	72	TC	50.5	50.5	50.5	48.2	48.2	48.2	45.6	45.6	45.6	42.7	42.7	42.7		
		SHC	20.9	27.4	33.8	20.3	26.7	33.1	19.5	25.9	32.3	18.7	25.1	31.5		
	76	TC	—	54.2	54.2	—	51.8	51.8	—	49.1	49.1	—	46.0	46.0		
		SHC	—	22.1	28.7	—	21.4	28.0	—	20.7	27.3	—	19.9	26.4		
	1500 cfm	EA (wb)	58	TC	43.6	43.6	49.0	42.0	42.0	47.1	40.1	40.1	45.0	37.9	37.9	42.5
				SHC	38.2	43.6	49.0	36.8	42.0	47.1	35.2	40.1	45.0	33.3	37.9	42.5
62			TC	43.7	43.7	50.9	42.0	42.0	48.9	40.1	40.1	46.6	37.9	37.9	44.0	
			SHC	36.5	43.7	50.9	35.1	42.0	48.9	33.6	40.1	46.6	31.8	37.9	44.0	
67			TC	47.4	47.4	47.4	45.2	45.2	45.2	42.6	42.6	43.0	39.8	39.8	42.0	
			SHC	29.4	36.9	44.5	28.7	36.2	43.8	27.9	35.4	43.0	27.0	34.5	42.0	
72		TC	51.8	51.8	51.8	49.4	49.4	49.4	46.7	46.7	46.7	43.7	43.7	43.7		
		SHC	21.6	29.2	36.7	21.0	28.5	36.1	20.2	27.7	35.3	19.4	26.9	34.4		
76		TC	—	55.6	55.6	—	53.0	53.0	—	50.2	50.2	—	47.0	47.0		
		SHC	—	22.9	30.6	—	22.3	30.0	—	21.5	29.2	—	20.7	28.3		
1750 cfm		EA (wb)	58	TC	45.5	45.5	51.1	43.7	43.7	49.1	41.7	41.7	46.7	39.3	39.3	44.1
				SHC	39.8	45.5	51.1	38.3	43.7	49.1	36.6	41.7	46.7	34.6	39.3	44.1
	62		TC	45.5	45.5	53.0	43.7	43.7	50.9	41.7	41.7	48.5	39.4	39.4	45.7	
			SHC	38.0	45.5	53.0	36.5	43.7	50.9	34.9	41.7	48.5	33.0	39.4	45.7	
	67		TC	48.3	48.3	48.5	46.0	46.0	47.8	43.4	43.4	46.9	40.4	40.4	45.8	
			SHC	31.2	39.9	48.5	30.5	39.2	47.8	29.7	38.3	46.9	28.7	37.3	45.8	
	72	TC	52.8	52.8	52.8	50.3	50.3	50.3	47.5	47.5	47.5	44.3	44.3	44.3		
		SHC	22.2	30.9	39.5	21.5	30.2	38.8	20.8	29.4	38.1	19.9	28.5	37.2		
	76	TC	—	56.6	56.6	—	54.0	54.0	—	51.0	51.0	—	47.7	47.7		
		SHC	—	23.6	32.4	—	23.0	31.7	—	22.2	30.9	—	21.4	30.0		
	2000 cfm	EA (wb)	58	TC	46.9	46.9	52.8	45.1	45.1	50.6	43.0	43.0	48.2	40.5	40.5	45.4
				SHC	41.1	46.9	52.8	39.5	45.1	50.6	37.7	43.0	48.2	35.6	40.5	45.4
62			TC	47.0	47.0	54.8	45.1	45.1	52.5	43.0	43.0	50.0	40.6	40.6	47.1	
			SHC	39.2	47.0	54.8	37.7	45.1	52.5	36.0	43.0	50.0	34.0	40.6	47.1	
67			TC	49.0	49.0	52.4	46.6	46.6	51.5	43.9	43.9	50.5	41.0	41.0	49.3	
			SHC	32.9	42.6	52.4	32.2	41.9	51.5	31.3	40.9	50.5	30.3	39.8	49.3	
72		TC	53.5	53.5	53.5	50.9	50.9	50.9	48.1	48.1	48.1	44.9	44.9	44.9		
		SHC	22.7	32.4	42.2	22.0	31.8	41.5	21.3	31.0	40.7	20.4	30.1	39.8		
76		TC	—	57.4	57.4	—	54.7	54.7	—	51.7	51.7	—	48.3	48.3		
		SHC	—	24.2	34.0	—	23.5	33.3	—	22.8	32.5	—	21.9	31.6		
2250 cfm		EA (wb)	58	TC	48.2	48.2	54.2	46.2	46.2	52.0	44.0	44.0	49.4	41.5	41.5	46.5
				SHC	42.2	48.2	54.2	40.5	46.2	52.0	38.6	44.0	49.4	36.4	41.5	46.5
	62		TC	48.2	48.2	56.3	46.3	46.3	53.9	44.0	44.0	51.3	41.5	41.5	48.3	
			SHC	40.2	48.2	56.3	38.6	46.3	53.9	36.8	44.0	51.3	34.8	41.5	48.3	
	67		TC	49.6	49.6	55.9	47.1	47.1	55.0	44.5	44.5	53.8	41.8	41.8	49.8	
			SHC	34.5	45.2	55.9	33.8	44.4	55.0	32.8	43.3	53.8	30.7	40.2	49.8	
	72	TC	54.1	54.1	54.1	51.5	51.5	51.5	48.5	48.5	48.5	45.2	45.2	45.2		
		SHC	23.1	33.9	44.7	22.5	33.2	44.0	21.7	32.5	43.2	20.9	31.6	42.3		
	76	TC	—	58.0	58.0	—	55.2	55.2	—	52.1	52.1	—	48.7	48.7		
		SHC	—	24.6	35.5	—	24.0	34.8	—	23.2	33.9	—	22.3	32.9		

NOTE: See minimum-maximum airflow ratings on page 8.

LEGEND

—	— Do Not Operate
cfm	— Cubic Feet Per Minute (Supply Air)
EA (db)	— Entering Air Temperature (dry bulb)
EA (wb)	— Entering Air Temperature (wet bulb)
SHC	— Sensible Heat Capacity (1000 Btuh) Gross
TC	— Total Capacity (1000 Btuh) Gross

48/50GC*K06 — Unit with Humidi-MiZer System in Subcooling Mode — Cooling Capacities

TEMP (°F) AIR ENTERING CONDENSER (Edb)		AIR ENTERING EVAPORATOR — SCFM/BF								
		1500 / 0.01			2000 / 0.02			2500 / 0.03		
		Air Entering Evaporator — Ewb (°F)								
		72	67	62	72	67	62	72	67	62
75	TC	70.53	63.82	57.93	74.82	68.11	61.86	77.52	70.71	64.57
	SHC	31.69	38.87	46.41	35.70	45.42	55.15	38.93	51.09	62.60
	kW	3.69	3.60	3.53	4.01	3.92	3.83	4.46	4.37	4.24
85	TC	66.76	60.52	54.81	70.78	64.32	58.47	73.28	66.66	61.04
	SHC	28.23	35.82	43.51	31.98	41.90	52.01	34.99	47.32	59.27
	kW	4.07	3.99	3.91	4.40	4.30	4.21	4.85	4.74	4.62
95	TC	62.90	56.96	51.51	65.79	60.87	54.99	69.01	62.83	57.39
	SHC	24.70	32.54	40.45	27.31	35.91	48.77	31.01	43.78	55.84
	kW	4.50	4.41	4.32	4.79	4.75	4.64	5.29	5.18	5.05
105	TC	58.97	53.30	48.18	62.37	56.65	51.38	64.74	58.79	53.63
	SHC	21.09	29.16	37.39	24.21	34.81	45.42	27.02	40.02	52.29
	kW	4.97	4.88	4.79	5.30	5.20	5.10	5.77	5.65	5.51
115	TC	54.84	49.52	44.71	58.03	52.59	47.64	59.95	54.52	49.72
	SHC	17.27	25.65	34.16	20.15	31.02	41.94	22.46	36.02	48.59
	kW	5.47	5.37	5.28	5.80	5.69	5.59	6.26	6.15	6.00
125	TC	50.51	45.56	41.08	53.44	48.35	43.92	55.25	50.08	45.85
	SHC	13.25	21.95	30.77	15.81	27.04	38.49	17.95	31.80	43.60
	kW	5.98	5.87	5.78	6.31	6.20	6.10	6.78	6.66	6.50

48/50GC*K06 — Unit with Humidi-MiZer System in Hot Gas Reheat Mode — Cooling Capacities

TEMP (°F) AIR ENTERING CONDENSER (Edb)		AIR ENTERING EVAPORATOR — Ewb (°F)								
		75 Dry Bulb 62.5 Wet Bulb (50% Relative)			75 Dry Bulb 64 Wet Bulb (56% Relative)			75 Dry Bulb 65.3 Wet Bulb (60% Relative)		
		Air Entering Evaporator — cfm								
		1500	2000	2500	1500	2000	2500	1500	2000	2500
80	TC	23.46	25.00	25.95	22.48	22.48	26.91	25.27	26.79	27.74
	SHC	6.67	10.43	14.23	-1.35	-1.35	10.30	2.67	4.90	6.94
	kW	3.23	3.51	3.93	3.79	3.79	3.97	3.29	3.57	4.00
75	TC	21.82	23.33	24.27	22.73	24.25	25.19	23.51	25.04	25.99
	SHC	3.89	7.28	10.74	1.53	4.07	6.48	-0.49	1.33	2.93
	kW	3.32	3.60	4.02	3.36	3.64	4.06	3.40	3.67	4.09
70	TC	20.22	21.70	22.63	21.08	22.57	23.50	21.85	23.33	24.28
	SHC	1.51	4.73	8.05	-1.10	1.16	3.38	-3.29	-1.82	-0.53
	kW	3.45	3.72	4.15	3.48	3.75	4.18	3.50	3.78	4.20
60	TC	27.06	28.61	29.62	27.75	27.75	29.00	28.77	28.77	31.52
	SHC	13.18	17.91	22.76	14.66	14.66	2.96	0.10	0.10	16.05
	kW	3.06	3.34	3.75	3.38	3.38	3.62	3.26	3.26	3.82
50	TC	26.27	27.80	28.76	27.09	28.59	29.59	27.83	29.36	30.33
	SHC	6.87	10.27	13.81	3.94	2.57	8.90	1.39	3.02	4.68
	kW	3.28	3.61	4.07	3.33	3.71	4.12	3.38	3.71	4.17
40	TC	29.29	30.82	31.80	30.18	31.72	32.69	30.98	32.52	33.50
	SHC	10.58	13.95	17.49	7.83	10.24	12.81	5.42	7.07	8.76
	kW	3.06	3.38	3.84	3.11	3.44	3.89	3.15	3.48	3.94

LEGEND

- Edb — Entering Dry Bulb
- Ewb — Entering Wet Bulb
- kW — Compressor Power Input
- SCFM/BF — Standard Cubic Feet per Minute/Bypass Factor
- SHC — Sensible Heat Capacity (1000 Btuh) Gross
- TC — Total Capacity (1000 Btuh) Gross

Pressure Drops for Gas and Electric Heating Units

Pressure Drop for Electric Heat 3 Ton Units — 1 Stage Heat

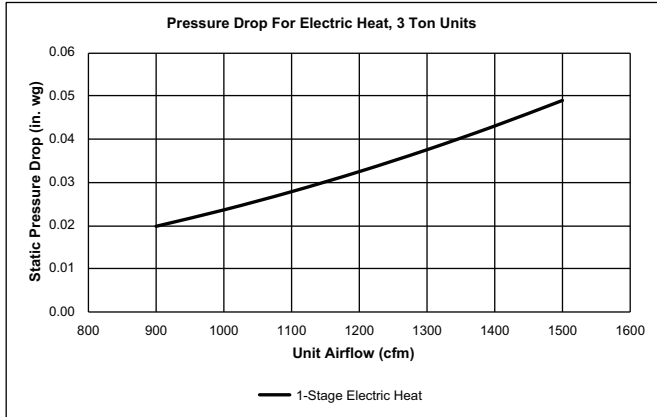

Pressure Drop for Electric Heat 4 and 5 Ton Units — 1 and 2 Stage Heat

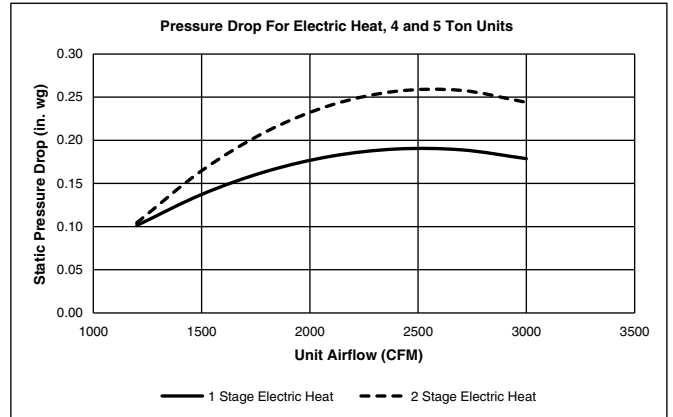

Single Phase Gas Heat Stages

UNIT SIZE	HEAT SIZE		
	Low	Med	High
1 Phase			
04	1	1	—
05	1	1	1
06	1	1	1

Three Phase Gas Heat Stages

UNIT SIZE	HEAT SIZE		
	Low	Med	High
3 Phase			
04	2	2	—
05	2	2	2
06	2	2	2

Gas Heat Static Pressure Deductions (in. wg) — 3 Ton Units

CFM	900	1000	1100	1200	1300	1400	1500
Low Gas Heat	0.01	0.01	0.02	0.03	0.03	0.04	0.04

Gas Heat Static Pressure Deductions (in. wg) — 4 to 5 Ton Units

CFM	1200	1500	1800	2100	2400	2700	3000
Medium Gas Heat	0.01	0.05	0.08	0.12	0.15	0.18	0.20
Low Gas Heat	0.03	0.10	0.17	0.23	0.29	0.36	0.42

Factory-Installed Electric Heat Stages for 50GC 208/230-3-60 Voltage Units

UNIT SIZE	HEAT SIZE		
	Low	Medium	High
04	1	1	1
05	1	1	2
06	1	2	2

Factory-Installed Electric Heat Stages for 50GC 460-3-60 Voltage Unit

UNIT SIZE	HEAT SIZE		
	Low	Medium	High
04	1	1	1
05	1	1	1
06	1	1	2

Factory-Installed Electric Heater Staging Data for 50GC UNITS

UNIT	VOLT-Ph-Hz	HEAT SIZE	FIOF HEATER NO.	NOMINAL kW	STAGES
50GC**04	208/230-3-60	Low	CRHEATER323A00	4.4	1
		Medium	CRHEATER326A00	10.5	1
		High	CRHEATER328A00	15.5	1
	460-3-60	Low	CRHEATER333A00	6.0	1
		Medium	CRHEATER335A00	11.5	1
		High	CRHEATER336A00	14.0	1
50GC**05	208/230-3-60	Low	CRHEATER323A00	4.4	1
		Medium	CRHEATER326A00	10.5	1
		High	CRHEATER329A00	17.4	2
	460-3-60	Low	CRHEATER333A00	6.0	1
		Medium	CRHEATER335A00	11.5	1
		High	CRHEATER336A00	14.0	1
50GC**06	208/230-3-60	Low	CRHEATER324A00	6.5	1
		Medium	CRHEATER329A00	17.4	2
		High	CRHEATER332A00	24.5	2
	460-3-60	Low	CRHEATER333A00	6.0	1
		Medium	CRHEATER335A00	11.5	1
		High	CRHEATER338A00	24.0	2

Field-Installed Accessory Electric Heater Data

50GFC UNIT SIZE	VOLTAGE	HEATER MODEL NO. ^a	NUMBER OF STAGES	
04	208/230	CRHEATER323A00	1	
		CRHEATER324A00	1	
		CRHEATER325A00	1	
		CRHEATER326A00	1	
		CRHEATER327A00	2	
		CRHEATER328A00	1	
	460	CRHEATER333A00	1	
		CRHEATER334A00	1	
		CRHEATER335A00	1	
		CRHEATER336A00	1	
		CRHEATER339A00	1	
		CRHEATER340A00	1	
05	208/230	CRHEATER323A00	1	
		CRHEATER324A00	1	
		CRHEATER325A00	1	
		CRHEATER326A00	1	
		CRHEATER327A00	2	
		CRHEATER328A00	1	
		CRHEATER329A00	2	
		CRHEATER330A00 ^b	2	
		CRHEATER331A00 ^c	2	
	460	CRHEATER333A00	1	
		CRHEATER335A00	1	
		CRHEATER336A00	1	
		CRHEATER337A00	2	
		CRHEATER339A00	1	
		CRHEATER340A00	1	
		575	CRHEATER324A00	1
			CRHEATER325A00	1
			CRHEATER326A00	1
CRHEATER327A00	2			
CRHEATER328A00	1			
CRHEATER329A00	2			
CRHEATER331A00	2			
CRHEATER332A00	2			
CRHEATER333A00	1			
06	208/230	CRHEATER335A00	1	
		CRHEATER336A00	1	
		CRHEATER337A00	2	
		CRHEATER338A00	2	
		CRHEATER340A00	1	
		CRHEATER341A00	2	
	460	CRHEATER333A00	1	
		CRHEATER335A00	1	
		CRHEATER336A00	1	
		CRHEATER337A00	2	
		CRHEATER338A00	2	
		CRHEATER340A00	1	
575	CRHEATER340A00	1		
	CRHEATER341A00	2		

NOTE(S):

- a. Check heater nameplate for model number.
- b. Do not use with size 05 horizontal supply duct configuration units.
- c. Do not use with size 05 vertical supply duct configuration units.

Use of CRHEATER330A00 for 50GC Units (with or without non-fused disconnect)

DUCT CONFIGURATION	50GC UNIT SIZE		
	04	05	06
Vertical Supply	—	Available	—
Horizontal Supply	—	—	—

Use of CRHEATER331A00 for 50GC Units (with or without non-fused disconnect)

DUCT CONFIGURATION	50GC UNIT SIZE		
	04	05	06
Vertical Supply	—	—	Available
Horizontal Supply	—	Available	Available

Economizer Barometric Relief and Static Pressure

Horizontal Economizer Barometric Relief

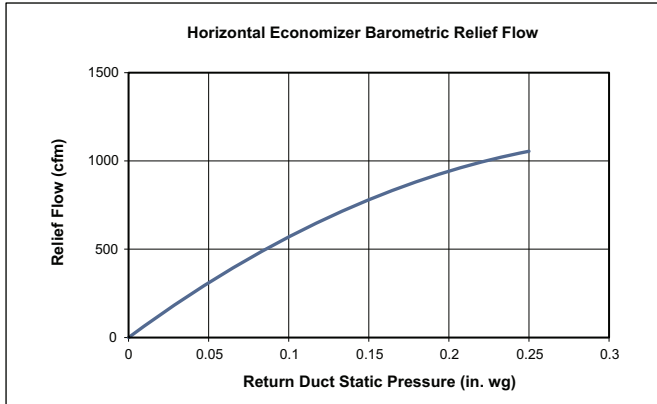

Vertical Economizer Barometric Relief

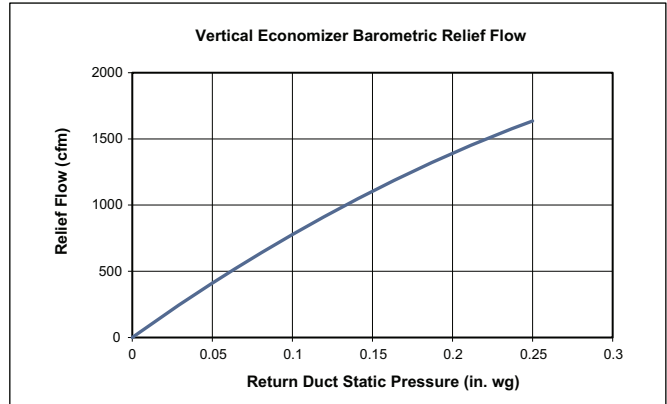

Horizontal Economizer Damper Leakage

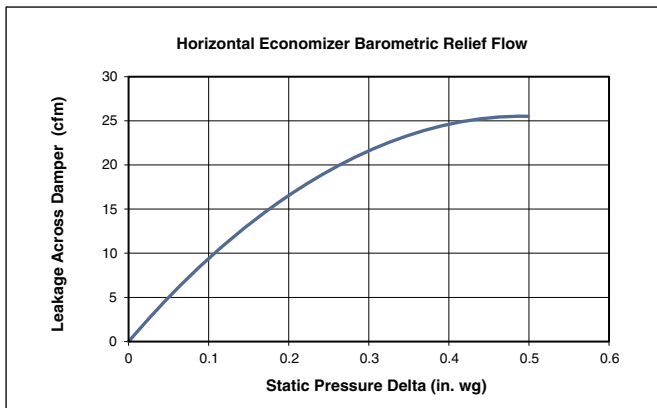

Vertical Economizer Damper Leakage

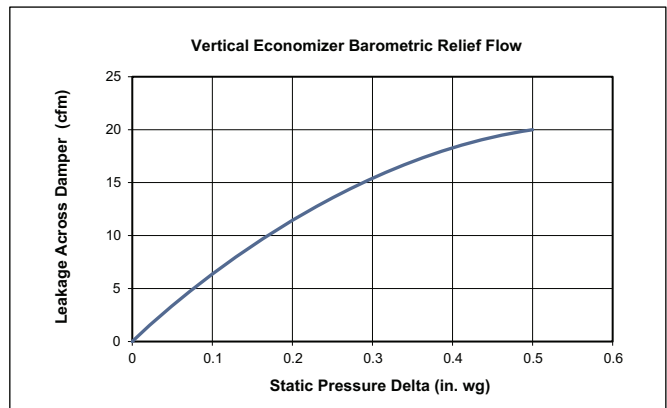

Humidi-MiZer® Coil Pressure Drops

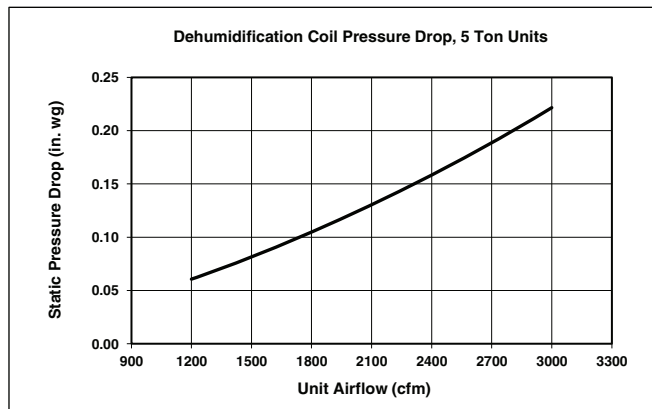
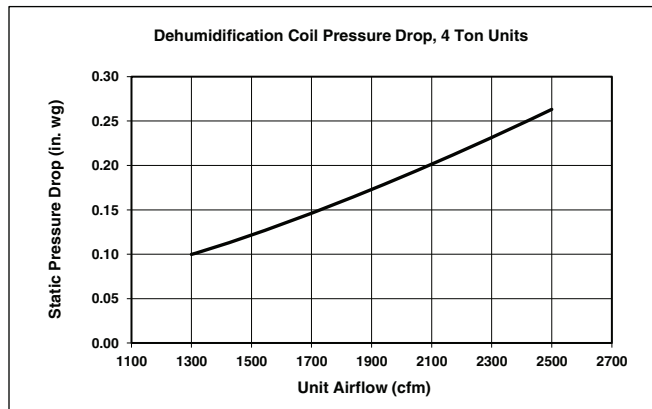
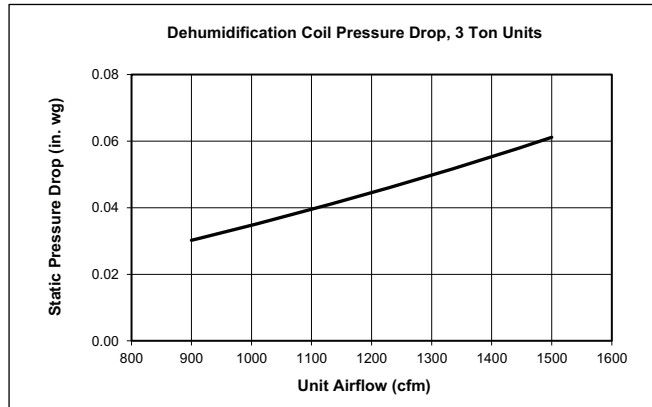

MERV-13 filters pressure drop

NOTE: For factory-installed MERV-13 filters, no additional pressure drop adjustments are necessary. The standard fan tables accommodate usage.

GENERAL FAN PERFORMANCE NOTES

1. Interpolation is permissible. Do not extrapolate.
2. External static pressure is the static pressure difference between the return duct and the supply duct plus the static pressure caused by any FIOPs or accessories.
3. Tabular data accounts for pressure loss due to clean filters, unit casing, wet coils, and highest gas heat exchanger (when gas heat unit).
4. Factory options and accessories may effect static pressure losses. Gas heat unit fan tables assume highest gas heat models; for fan selections with low or medium heat models, the user must deduct low and medium heat static pressures. Selection software is available, through your salesperson, to help you select the best motor/drive combination for your application.
5. The fan performance tables offer motor/drive recommendations. In cases when 2 motor/drive combinations would work, Carrier recommends the lower horsepower option.
6. For information on the electrical properties of Carrier motors, please see the Electrical information section of this book.
7. For more information on the performance limits of Carrier motors, see the application data section of this book.
8. The EPACT (Energy Policy Act of 1992) regulates energy requirements for specific types of indoor fan motors. Motors regulated by EPACT include any general purpose, T-frame (3-digit, 143 and larger), single-speed, foot mounted, polyphase, squirrel cage induction motors of NEMA (National Electrical Manufacturers Association) design A and B, manufactured for use in the United States. Ranging from 1 to 200 Hp, these continuous-duty motors operate on 230 and 460 volt, 60 Hz power. If a motor does not fit into these specifications, the motor does not have to be replaced by an EPACT compliant energy-efficient motor. Variable-speed motors are exempt from EPACT compliance requirements.

48GCET04 Single Phase — 3 Ton Vertical Supply (rpm - bhp)

CFM	AVAILABLE EXTERNAL STATIC PRESSURE (in. wg)									
	0.2		0.4		0.6		0.8		1.0	
	rpm	bhp	rpm	bhp	rpm	bhp	rpm	bhp	rpm	bhp
900	1129	0.10	1356	0.17	1544	0.26	1708	0.35	1857	0.45
975	1182	0.11	1402	0.19	1586	0.28	1748	0.37	1894	0.47
1050	1236	0.13	1449	0.21	1630	0.30	1789	0.40	1933	0.50
1125	1290	0.15	1498	0.23	1675	0.33	1831	0.43	1973	0.53
1200	1346	0.17	1547	0.26	1721	0.35	1874	0.46	2014	0.57
1275	1403	0.19	1598	0.28	1768	0.38	1919	0.49	2057	0.61
1350	1460	0.22	1651	0.31	1816	0.42	1965	0.53	2100	0.64
1425	1519	0.24	1703	0.34	1865	0.45	2012	0.57	2145	0.69
1500	1579	0.27	1757	0.38	1916	0.49	2059	0.61	2191	0.73

CFM	AVAILABLE EXTERNAL STATIC PRESSURE (in. wg)									
	1.2		1.4		1.6		1.8		2.0	
	rpm	bhp	rpm	bhp	rpm	bhp	rpm	bhp	rpm	bhp
900	1994	0.55	2121	0.66	2241	0.78	2354	0.91	2461	1.04
975	2029	0.58	2155	0.70	2274	0.82	2386	0.95	—	—
1050	2066	0.61	2190	0.73	2307	0.86	2419	0.99	—	—
1125	2104	0.65	2227	0.77	2343	0.90	2453	1.03	—	—
1200	2144	0.69	2265	0.81	2379	0.94	2488	1.07	—	—
1275	2184	0.73	2304	0.85	2417	0.98	—	—	—	—
1350	2226	0.77	2345	0.90	2456	1.03	—	—	—	—
1425	2269	0.81	2386	0.95	—	—	—	—	—	—
1500	2313	0.86	2429	1.00	—	—	—	—	—	—

Standard Static 1129-1890 rpm, 0.44 max bhp

Medium Static 1129-2190 rpm, 0.71 max bhp

High Static 1129-2490 rpm, 1.07 max bhp

NOTE: Fan tables include highest gas heat. Utilize static pressure deduction tables on page 39 for lower gas heat capacities.

48GCET04 Single Phase — Standard Static — 3 Ton Vertical Supply (rpm - vdc)

CFM	AVAILABLE EXTERNAL STATIC PRESSURE (in. wg)									
	0.2		0.4		0.6		0.8		1.0	
	rpm	vdc	rpm	vdc	rpm	vdc	rpm	vdc	rpm	vdc
900	1129	6.0	1356	7.2	1544	8.2	1708	9.0	—	—
975	1182	6.3	1402	7.4	1586	8.4	1748	9.2	—	—
1050	1236	6.5	1449	7.7	1630	8.6	1789	9.5	—	—
1125	1290	6.8	1498	7.9	1675	8.9	1831	9.7	—	—
1200	1346	7.1	1547	8.2	1721	9.1	—	—	—	—
1275	1403	7.4	1598	8.5	1768	9.4	—	—	—	—
1350	1460	7.7	1651	8.7	1816	9.6	—	—	—	—
1425	1519	8.0	1703	9.0	—	—	—	—	—	—
1500	1579	8.4	1757	9.3	—	—	—	—	—	—

CFM	AVAILABLE EXTERNAL STATIC PRESSURE (in. wg)									
	1.2		1.4		1.6		1.8		2.0	
	rpm	vdc	rpm	vdc	rpm	vdc	rpm	vdc	rpm	vdc
900	—	—	—	—	—	—	—	—	—	—
975	—	—	—	—	—	—	—	—	—	—
1050	—	—	—	—	—	—	—	—	—	—
1125	—	—	—	—	—	—	—	—	—	—
1200	—	—	—	—	—	—	—	—	—	—
1275	—	—	—	—	—	—	—	—	—	—
1350	—	—	—	—	—	—	—	—	—	—
1425	—	—	—	—	—	—	—	—	—	—
1500	—	—	—	—	—	—	—	—	—	—

Standard Static 1129-1890 rpm

NOTE: Fan tables include highest gas heat. Utilize static pressure deduction tables on page 39 for lower gas heat capacities.

48GCET04 Single Phase — Medium Static — 3 Ton Vertical Supply (rpm - vdc)

CFM	AVAILABLE EXTERNAL STATIC PRESSURE (in. wg)									
	0.2		0.4		0.6		0.8		1.0	
	rpm	vdc	rpm	vdc	rpm	vdc	rpm	vdc	rpm	vdc
900	1129	5.2	1356	6.2	1544	7.1	1708	7.8	1857	8.5
975	1182	5.4	1402	6.4	1586	7.2	1748	8.0	1894	8.6
1050	1236	5.6	1449	6.6	1630	7.4	1789	8.2	1933	8.8
1125	1290	5.9	1498	6.8	1675	7.6	1831	8.4	1973	9.0
1200	1346	6.1	1547	7.1	1721	7.9	1874	8.6	2014	9.2
1275	1403	6.4	1598	7.3	1768	8.1	1919	8.8	2057	9.4
1350	1460	6.7	1651	7.5	1816	8.3	1965	9.0	2100	9.6
1425	1519	6.9	1703	7.8	1865	8.5	2012	9.2	2145	9.8
1500	1579	7.2	1757	8.0	1916	8.7	2059	9.4	—	—

CFM	AVAILABLE EXTERNAL STATIC PRESSURE (in. wg)									
	1.2		1.4		1.6		1.8		2.0	
	rpm	vdc	rpm	vdc	rpm	vdc	rpm	vdc	rpm	vdc
900	1994	9.1	2121	9.7	—	—	—	—	—	—
975	2029	9.3	2155	9.8	—	—	—	—	—	—
1050	2066	9.4	—	—	—	—	—	—	—	—
1125	2104	9.6	—	—	—	—	—	—	—	—
1200	2144	9.8	—	—	—	—	—	—	—	—
1275	—	—	—	—	—	—	—	—	—	—
1350	—	—	—	—	—	—	—	—	—	—
1425	—	—	—	—	—	—	—	—	—	—
1500	—	—	—	—	—	—	—	—	—	—

Medium Static 1129-2190 rpm

NOTE: Fan tables include highest gas heat. Utilize static pressure deduction tables on page 39 for lower gas heat capacities.

48GCET04 Single Phase — High Static — 3 Ton Vertical Supply (rpm - vdc)

CFM	AVAILABLE EXTERNAL STATIC PRESSURE (in. wg)									
	0.2		0.4		0.6		0.8		1.0	
	rpm	vdc	rpm	vdc	rpm	vdc	rpm	vdc	rpm	vdc
900	1129	4.5	1356	5.4	1544	6.2	1708	6.9	1857	7.5
975	1182	4.7	1402	5.6	1586	6.4	1748	7.0	1894	7.6
1050	1236	5.0	1449	5.8	1630	6.5	1789	7.2	1933	7.8
1125	1290	5.2	1498	6.0	1675	6.7	1831	7.4	1973	7.9
1200	1346	5.4	1547	6.2	1721	6.9	1874	7.5	2014	8.1
1275	1403	5.6	1598	6.4	1768	7.1	1919	7.7	2057	8.3
1350	1460	5.9	1651	6.6	1816	7.3	1965	7.9	2100	8.4
1425	1519	6.1	1703	6.8	1865	7.5	2012	8.1	2145	8.6
1500	1579	6.3	1757	7.1	1916	7.7	2059	8.3	2191	8.8

CFM	AVAILABLE EXTERNAL STATIC PRESSURE (in. wg)									
	1.2		1.4		1.6		1.8		2.0	
	rpm	vdc	rpm	vdc	rpm	vdc	rpm	vdc	rpm	vdc
900	1994	8.0	2121	8.5	2241	9.0	2354	9.5	2461	9.9
975	2029	8.1	2155	8.7	2274	9.1	2386	9.6	—	—
1050	2066	8.3	2190	8.8	2307	9.3	2419	9.7	—	—
1125	2104	8.4	2227	8.9	2343	9.4	2453	9.9	—	—
1200	2144	8.6	2265	9.1	2379	9.6	2488	10.0	—	—
1275	2184	8.8	2304	9.3	2417	9.7	—	—	—	—
1350	2226	8.9	2345	9.4	2456	9.9	—	—	—	—
1425	2269	9.1	2386	9.6	—	—	—	—	—	—
1500	2313	9.3	2429	9.8	—	—	—	—	—	—

High Static 1129-2490 rpm

NOTE: Fan tables include highest gas heat. Utilize static pressure deduction tables on page 39 for lower gas heat capacities.

48GCEJ04 Three Phase — 3 Ton Vertical Supply (rpm - bhp)

CFM	AVAILABLE EXTERNAL STATIC PRESSURE (in. wg)									
	0.2		0.4		0.6		0.8		1.0	
	rpm	bhp	rpm	bhp	rpm	bhp	rpm	bhp	rpm	bhp
900	1129	0.10	1356	0.17	1544	0.26	1708	0.35	1857	0.45
975	1182	0.11	1402	0.19	1586	0.28	1748	0.37	1894	0.47
1050	1236	0.13	1449	0.21	1630	0.30	1789	0.40	1933	0.50
1125	1290	0.15	1498	0.23	1675	0.33	1831	0.43	1973	0.53
1200	1346	0.17	1547	0.26	1721	0.35	1874	0.46	2014	0.57
1275	1403	0.19	1598	0.28	1768	0.38	1919	0.49	2057	0.61
1350	1460	0.22	1651	0.31	1816	0.42	1965	0.53	2100	0.64
1425	1519	0.24	1703	0.34	1865	0.45	2012	0.57	2145	0.69
1500	1579	0.27	1757	0.38	1916	0.49	2059	0.61	2191	0.73

CFM	AVAILABLE EXTERNAL STATIC PRESSURE (in. wg)									
	1.2		1.4		1.6		1.8		2.0	
	rpm	bhp	rpm	bhp	rpm	bhp	rpm	bhp	rpm	bhp
900	1994	0.55	2121	0.66	2241	0.78	2354	0.91	2461	1.04
975	2029	0.58	2155	0.70	2274	0.82	2386	0.95	—	—
1050	2066	0.61	2190	0.73	2307	0.86	2419	0.99	—	—
1125	2104	0.65	2227	0.77	2343	0.90	2453	1.03	—	—
1200	2144	0.69	2265	0.81	2379	0.94	2488	1.07	—	—
1275	2184	0.73	2304	0.85	2417	0.98	—	—	—	—
1350	2226	0.77	2345	0.90	2456	1.03	—	—	—	—
1425	2269	0.81	2386	0.95	—	—	—	—	—	—
1500	2313	0.86	2429	1.00	—	—	—	—	—	—

- Standard Static 1129-1890 rpm, 0.44 max bhp
- Medium Static 1129-2190 rpm, 0.71 max bhp
- High Static 1129-2490 rpm, 1.07 max bhp

NOTE: Fan tables include highest gas heat. Utilize static pressure deduction tables on page 39 for lower gas heat capacities.

48GCEJ04 Three Phase — Standard Static — 3 Ton Vertical Supply (rpm - vdc)

CFM	AVAILABLE EXTERNAL STATIC PRESSURE (in. wg)									
	0.2		0.4		0.6		0.8		1.0	
	rpm	vdc	rpm	vdc	rpm	vdc	rpm	vdc	rpm	vdc
900	1129	6.0	1356	7.2	1544	8.2	1708	9.0	—	—
975	1182	6.3	1402	7.4	1586	8.4	1748	9.2	—	—
1050	1236	6.5	1449	7.7	1630	8.6	1789	9.5	—	—
1125	1290	6.8	1498	7.9	1675	8.9	1831	9.7	—	—
1200	1346	7.1	1547	8.2	1721	9.1	—	—	—	—
1275	1403	7.4	1598	8.5	1768	9.4	—	—	—	—
1350	1460	7.7	1651	8.7	1816	9.6	—	—	—	—
1425	1519	8.0	1703	9.0	—	—	—	—	—	—
1500	1579	8.4	1757	9.3	—	—	—	—	—	—

CFM	AVAILABLE EXTERNAL STATIC PRESSURE (in. wg)									
	1.2		1.4		1.6		1.8		2.0	
	rpm	vdc	rpm	vdc	rpm	vdc	rpm	vdc	rpm	vdc
900	—	—	—	—	—	—	—	—	—	—
975	—	—	—	—	—	—	—	—	—	—
1050	—	—	—	—	—	—	—	—	—	—
1125	—	—	—	—	—	—	—	—	—	—
1200	—	—	—	—	—	—	—	—	—	—
1275	—	—	—	—	—	—	—	—	—	—
1350	—	—	—	—	—	—	—	—	—	—
1425	—	—	—	—	—	—	—	—	—	—
1500	—	—	—	—	—	—	—	—	—	—

- Standard Static 1129-1890 rpm

NOTE: Fan tables include highest gas heat. Utilize static pressure deduction tables on page 39 for lower gas heat capacities.

48GCEJ04 Three Phase — Medium Static — 3 Ton Vertical Supply (rpm - vdc)

CFM	AVAILABLE EXTERNAL STATIC PRESSURE (in. wg)									
	0.2		0.4		0.6		0.8		1.0	
	rpm	vdc	rpm	vdc	rpm	vdc	rpm	vdc	rpm	vdc
900	1129	5.2	1356	6.2	1544	7.1	1708	7.8	1857	8.5
975	1182	5.4	1402	6.4	1586	7.2	1748	8.0	1894	8.6
1050	1236	5.6	1449	6.6	1630	7.4	1789	8.2	1933	8.8
1125	1290	5.9	1498	6.8	1675	7.6	1831	8.4	1973	9.0
1200	1346	6.1	1547	7.1	1721	7.9	1874	8.6	2014	9.2
1275	1403	6.4	1598	7.3	1768	8.1	1919	8.8	2057	9.4
1350	1460	6.7	1651	7.5	1816	8.3	1965	9.0	2100	9.6
1425	1519	6.9	1703	7.8	1865	8.5	2012	9.2	2145	9.8
1500	1579	7.2	1757	8.0	1916	8.7	2059	9.4	—	—

CFM	AVAILABLE EXTERNAL STATIC PRESSURE (in. wg)									
	1.2		1.4		1.6		1.8		2.0	
	rpm	vdc	rpm	vdc	rpm	vdc	rpm	vdc	rpm	vdc
900	1994	9.1	2121	9.7	—	—	—	—	—	—
975	2029	9.3	2155	9.8	—	—	—	—	—	—
1050	2066	9.4	—	—	—	—	—	—	—	—
1125	2104	9.6	—	—	—	—	—	—	—	—
1200	2144	9.8	—	—	—	—	—	—	—	—
1275	—	—	—	—	—	—	—	—	—	—
1350	—	—	—	—	—	—	—	—	—	—
1425	—	—	—	—	—	—	—	—	—	—
1500	—	—	—	—	—	—	—	—	—	—

Medium Static 1129-2190 rpm

NOTE: Fan tables include highest gas heat. Utilize static pressure deduction tables on page 39 for lower gas heat capacities.

48GCEJ04 Three Phase — High Static — 3 Ton Vertical Supply (rpm - vdc)

CFM	AVAILABLE EXTERNAL STATIC PRESSURE (in. wg)									
	0.2		0.4		0.6		0.8		1.0	
	rpm	vdc	rpm	vdc	rpm	vdc	rpm	vdc	rpm	vdc
900	1129	4.5	1356	5.4	1544	6.2	1708	6.9	1857	7.5
975	1182	4.7	1402	5.6	1586	6.4	1748	7.0	1894	7.6
1050	1236	5.0	1449	5.8	1630	6.5	1789	7.2	1933	7.8
1125	1290	5.2	1498	6.0	1675	6.7	1831	7.4	1973	7.9
1200	1346	5.4	1547	6.2	1721	6.9	1874	7.5	2014	8.1
1275	1403	5.6	1598	6.4	1768	7.1	1919	7.7	2057	8.3
1350	1460	5.9	1651	6.6	1816	7.3	1965	7.9	2100	8.4
1425	1519	6.1	1703	6.8	1865	7.5	2012	8.1	2145	8.6
1500	1579	6.3	1757	7.1	1916	7.7	2059	8.3	2191	8.8

CFM	AVAILABLE EXTERNAL STATIC PRESSURE (in. wg)									
	1.2		1.4		1.6		1.8		2.0	
	rpm	vdc	rpm	vdc	rpm	vdc	rpm	vdc	rpm	vdc
900	1994	8.0	2121	8.5	2241	9.0	2354	9.5	2461	9.9
975	2029	8.1	2155	8.7	2274	9.1	2386	9.6	—	—
1050	2066	8.3	2190	8.8	2307	9.3	2419	9.7	—	—
1125	2104	8.4	2227	8.9	2343	9.4	2453	9.9	—	—
1200	2144	8.6	2265	9.1	2379	9.6	2488	10.0	—	—
1275	2184	8.8	2304	9.3	2417	9.7	—	—	—	—
1350	2226	8.9	2345	9.4	2456	9.9	—	—	—	—
1425	2269	9.1	2386	9.6	—	—	—	—	—	—
1500	2313	9.3	2429	9.8	—	—	—	—	—	—

High Static 1129-2490 rpm

NOTE: Fan tables include highest gas heat. Utilize static pressure deduction tables on page 39 for lower gas heat capacities.

48GCFT05 Single Phase — 4 Ton Vertical Supply (rpm - bhp)

CFM	AVAILABLE EXTERNAL STATIC PRESSURE (in. wg)									
	0.2		0.4		0.6		0.8		1.0	
	rpm	bhp	rpm	bhp	rpm	bhp	rpm	bhp	rpm	bhp
1200	1262	0.21	1453	0.33	1614	0.45	1757	0.58	1888	0.72
1300	1333	0.25	1517	0.37	1674	0.50	1813	0.63	1942	0.78
1400	1405	0.29	1583	0.42	1735	0.55	1872	0.70	1997	0.84
1500	1478	0.34	1650	0.48	1799	0.62	1932	0.76	2055	0.92
1600	1552	0.40	1718	0.54	1863	0.68	1994	0.84	2114	1.00
1700	1627	0.46	1787	0.60	1929	0.76	2057	0.92	2174	1.09
1800	1704	0.52	1857	0.68	1995	0.84	2121	1.01	2236	1.18
1900	1781	0.60	1929	0.76	2063	0.93	2186	1.10	2299	1.28
2000	1859	0.68	2001	0.85	2132	1.02	2252	1.21	2363	1.39

CFM	AVAILABLE EXTERNAL STATIC PRESSURE (in. wg)									
	1.2		1.4		1.6		1.8		2.0	
	rpm	bhp	rpm	bhp	rpm	bhp	rpm	bhp	rpm	bhp
1200	2011	0.87	2126	1.02	2236	1.19	2341	1.37	—	—
1300	2061	0.93	2174	1.09	2281	1.26	2383	1.44	—	—
1400	2114	1.00	2224	1.17	2329	1.34	2429	1.52	—	—
1500	2169	1.08	2277	1.25	2379	1.43	—	—	—	—
1600	2226	1.17	2331	1.34	2432	1.52	—	—	—	—
1700	2284	1.26	2388	1.44	—	—	—	—	—	—
1800	2344	1.36	2446	1.55	—	—	—	—	—	—
1900	2405	1.47	—	—	—	—	—	—	—	—
2000	—	—	—	—	—	—	—	—	—	—

- Standard Static 1262-1900 rpm, 0.72 max bhp
- Medium Static 1262-2170 rpm, 1.06 max bhp
- High Static 1262-2460 rpm, 1.53 max bhp

NOTE: Fan tables include highest gas heat. Utilize static pressure deduction tables on page 39 for lower gas heat capacities.

48GCFT05 Single Phase — Standard Static — 4 Ton Vertical Supply (rpm - vdc)

CFM	AVAILABLE EXTERNAL STATIC PRESSURE (in. wg)									
	0.2		0.4		0.6		0.8		1.0	
	rpm	vdc	rpm	vdc	rpm	vdc	rpm	vdc	rpm	vdc
1200	1262	6.6	1453	7.6	1614	8.5	1757	9.2	1888	9.9
1300	1333	7.0	1517	8.0	1674	8.8	1813	9.5	—	—
1400	1405	7.4	1583	8.3	1735	9.1	1872	9.9	—	—
1500	1478	7.8	1650	8.7	1799	9.5	—	—	—	—
1600	1552	8.2	1718	9.0	1863	9.8	—	—	—	—
1700	1627	8.6	1787	9.4	—	—	—	—	—	—
1800	1704	9.0	1857	9.8	—	—	—	—	—	—
1900	1781	9.4	—	—	—	—	—	—	—	—
2000	1859	9.8	—	—	—	—	—	—	—	—

CFM	AVAILABLE EXTERNAL STATIC PRESSURE (in. wg)									
	1.2		1.4		1.6		1.8		2.0	
	rpm	vdc	rpm	vdc	rpm	vdc	rpm	vdc	rpm	vdc
1200	—	—	—	—	—	—	—	—	—	—
1300	—	—	—	—	—	—	—	—	—	—
1400	—	—	—	—	—	—	—	—	—	—
1500	—	—	—	—	—	—	—	—	—	—
1600	—	—	—	—	—	—	—	—	—	—
1700	—	—	—	—	—	—	—	—	—	—
1800	—	—	—	—	—	—	—	—	—	—
1900	—	—	—	—	—	—	—	—	—	—
2000	—	—	—	—	—	—	—	—	—	—

- Standard Static 1262-1900 rpm

NOTE: Fan tables include highest gas heat. Utilize static pressure deduction tables on page 39 for lower gas heat capacities.

48GCFT05 Single Phase — Medium Static — 4 Ton Vertical Supply (rpm - vdc)

CFM	AVAILABLE EXTERNAL STATIC PRESSURE (in. wg)									
	0.2		0.4		0.6		0.8		1.0	
	rpm	vdc	rpm	vdc	rpm	vdc	rpm	vdc	rpm	vdc
1200	1262	5.8	1453	6.7	1614	7.4	1757	8.1	1888	8.7
1300	1333	6.1	1517	7.0	1674	7.7	1813	8.4	1942	8.9
1400	1405	6.5	1583	7.3	1735	8.0	1872	8.6	1997	9.2
1500	1478	6.8	1650	7.6	1799	8.3	1932	8.9	2055	9.5
1600	1552	7.2	1718	7.9	1863	8.6	1994	9.2	2114	9.7
1700	1627	7.5	1787	8.2	1929	8.9	2057	9.5	—	—
1800	1704	7.9	1857	8.6	1995	9.2	2121	9.8	—	—
1900	1781	8.2	1929	8.9	2063	9.5	—	—	—	—
2000	1859	8.6	2001	9.2	2132	9.8	—	—	—	—

CFM	AVAILABLE EXTERNAL STATIC PRESSURE (in. wg)									
	1.2		1.4		1.6		1.8		2.0	
	rpm	vdc	rpm	vdc	rpm	vdc	rpm	vdc	rpm	vdc
1200	2011	9.3	2126	9.8	—	—	—	—	—	—
1300	2061	9.5	—	—	—	—	—	—	—	—
1400	2114	9.7	—	—	—	—	—	—	—	—
1500	—	—	—	—	—	—	—	—	—	—
1600	—	—	—	—	—	—	—	—	—	—
1700	—	—	—	—	—	—	—	—	—	—
1800	—	—	—	—	—	—	—	—	—	—
1900	—	—	—	—	—	—	—	—	—	—
2000	—	—	—	—	—	—	—	—	—	—

Medium Static 1262-2170 rpm

NOTE: Fan tables include highest gas heat. Utilize static pressure deduction tables on page 39 for lower gas heat capacities.

48GCFT05 Single Phase — High Static — 4 Ton Vertical Supply (rpm - vdc)

CFM	AVAILABLE EXTERNAL STATIC PRESSURE (in. wg)									
	0.2		0.4		0.6		0.8		1.0	
	rpm	vdc	rpm	vdc	rpm	vdc	rpm	vdc	rpm	vdc
1200	1262	5.1	1453	5.9	1614	6.6	1757	7.1	1888	7.7
1300	1333	5.4	1517	6.2	1674	6.8	1813	7.4	1942	7.9
1400	1405	5.7	1583	6.4	1735	7.1	1872	7.6	1997	8.1
1500	1478	6.0	1650	6.7	1799	7.3	1932	7.9	2055	8.4
1600	1552	6.3	1718	7.0	1863	7.6	1994	8.1	2114	8.6
1700	1627	6.6	1787	7.3	1929	7.8	2057	8.4	2174	8.8
1800	1704	6.9	1857	7.5	1995	8.1	2121	8.6	2236	9.1
1900	1781	7.2	1929	7.8	2063	8.4	2186	8.9	2299	9.3
2000	1859	7.6	2001	8.1	2132	8.7	2252	9.2	2363	9.6

CFM	AVAILABLE EXTERNAL STATIC PRESSURE (in. wg)									
	1.2		1.4		1.6		1.8		2.0	
	rpm	vdc	rpm	vdc	rpm	vdc	rpm	vdc	rpm	vdc
1200	2011	8.2	2126	8.6	2236	9.1	2341	9.5	2442	9.9
1300	2061	8.4	2174	8.8	2281	9.3	2383	9.7	—	—
1400	2114	8.6	2224	9.0	2329	9.5	2429	9.9	—	—
1500	2169	8.8	2277	9.3	2379	9.7	—	—	—	—
1600	2226	9.0	2331	9.5	2432	9.9	—	—	—	—
1700	2284	9.3	2388	9.7	—	—	—	—	—	—
1800	2344	9.5	2446	9.9	—	—	—	—	—	—
1900	2405	9.8	—	—	—	—	—	—	—	—
2000	—	—	—	—	—	—	—	—	—	—

High Static 1262-2460 rpm

NOTE: Fan tables include highest gas heat. Utilize static pressure deduction tables on page 39 for lower gas heat capacities.

48GCFJ05 Three Phase — 4 Ton Vertical Supply (rpm - bhp)

CFM	AVAILABLE EXTERNAL STATIC PRESSURE (in. wg)									
	0.2		0.4		0.6		0.8		1.0	
	rpm	bhp	rpm	bhp	rpm	bhp	rpm	bhp	rpm	bhp
1200	1262	0.21	1452	0.33	1614	0.45	1757	0.58	1888	0.72
1300	1333	0.25	1516	0.37	1674	0.50	1813	0.63	1942	0.78
1400	1405	0.29	1583	0.42	1735	0.55	1872	0.70	1997	0.84
1500	1478	0.34	1650	0.48	1798	0.62	1932	0.76	2054	0.92
1600	1552	0.40	1718	0.54	1863	0.68	1993	0.84	2114	1.00
1700	1627	0.46	1787	0.60	1928	0.76	2057	0.92	2174	1.09
1800	1704	0.52	1857	0.68	1995	0.84	2121	1.01	2236	1.18
1900	1781	0.60	1929	0.76	2063	0.93	2185	1.10	2299	1.28
2000	1859	0.68	2001	0.85	2132	1.02	2252	1.21	2363	1.39

CFM	AVAILABLE EXTERNAL STATIC PRESSURE (in. wg)									
	1.2		1.4		1.6		1.8		2.0	
	rpm	bhp	rpm	bhp	rpm	bhp	rpm	bhp	rpm	bhp
1200	2011	0.87	2126	1.02	2236	1.19	2341	1.37	2442	1.55
1300	2061	0.93	2174	1.09	2281	1.26	2384	1.44	2482	1.62
1400	2114	1.00	2224	1.17	2329	1.34	2429	1.52	2526	1.71
1500	2169	1.08	2277	1.25	2379	1.43	2477	1.61	2572	1.80
1600	2226	1.17	2331	1.34	2432	1.52	2528	1.71	2621	1.91
1700	2284	1.26	2388	1.44	2486	1.63	2581	1.82	—	—
1800	2344	1.36	2446	1.55	2543	1.74	2636	1.94	—	—
1900	2405	1.47	2505	1.66	2600	1.86	—	—	—	—
2000	2467	1.59	2565	1.78	2659	1.99	—	—	—	—

- Standard Static 1262-1900 rpm, 0.72 max bhp
- Medium Static 1262-2170 rpm, 1.06 max bhp
- High Static 1262-2660 rpm, 1.96 max bhp

NOTE: Fan tables include highest gas heat. Utilize static pressure deduction tables on page 39 for lower gas heat capacities.

48GCFJ05 Three Phase — Standard Static — 4 Ton Vertical Supply (rpm - vdc)

CFM	AVAILABLE EXTERNAL STATIC PRESSURE (in. wg)									
	0.2		0.4		0.6		0.8		1.0	
	rpm	vdc	rpm	vdc	rpm	vdc	rpm	vdc	rpm	vdc
1200	1262	6.6	1453	7.6	1614	8.5	1757	9.2	1888	9.9
1300	1333	7.0	1517	8.0	1674	8.8	1813	9.5	—	—
1400	1405	7.4	1583	8.3	1735	9.1	1872	9.9	—	—
1500	1478	7.8	1650	8.7	1799	9.5	—	—	—	—
1600	1552	8.2	1718	9.0	1863	9.8	—	—	—	—
1700	1627	8.6	1787	9.4	—	—	—	—	—	—
1800	1704	9.0	1857	9.8	—	—	—	—	—	—
1900	1781	9.4	—	—	—	—	—	—	—	—
2000	1859	9.8	—	—	—	—	—	—	—	—

CFM	AVAILABLE EXTERNAL STATIC PRESSURE (in. wg)									
	1.2		1.4		1.6		1.8		2.0	
	rpm	vdc	rpm	vdc	rpm	vdc	rpm	vdc	rpm	vdc
1200	—	—	—	—	—	—	—	—	—	—
1300	—	—	—	—	—	—	—	—	—	—
1400	—	—	—	—	—	—	—	—	—	—
1500	—	—	—	—	—	—	—	—	—	—
1600	—	—	—	—	—	—	—	—	—	—
1700	—	—	—	—	—	—	—	—	—	—
1800	—	—	—	—	—	—	—	—	—	—
1900	—	—	—	—	—	—	—	—	—	—
2000	—	—	—	—	—	—	—	—	—	—

- Standard Static 1262-1900 rpm

NOTE: Fan tables include highest gas heat. Utilize static pressure deduction tables on page 39 for lower gas heat capacities.

48GCFJ05 Three Phase — Medium Static — 4 Ton Vertical Supply (rpm - vdc)

CFM	AVAILABLE EXTERNAL STATIC PRESSURE (in. wg)									
	0.2		0.4		0.6		0.8		1.0	
	rpm	vdc	rpm	vdc	rpm	vdc	rpm	vdc	rpm	vdc
1200	1262	5.8	1453	6.7	1614	7.4	1757	8.1	1888	8.7
1300	1333	6.1	1517	7.0	1674	7.7	1813	8.4	1942	8.9
1400	1405	6.5	1583	7.3	1735	8.0	1872	8.6	1997	9.2
1500	1478	6.8	1650	7.6	1799	8.3	1932	8.9	2055	9.5
1600	1552	7.2	1718	7.9	1863	8.6	1994	9.2	2114	9.7
1700	1627	7.5	1787	8.2	1929	8.9	2057	9.5	—	—
1800	1704	7.9	1857	8.6	1995	9.2	2121	9.8	—	—
1900	1781	8.2	1929	8.9	2063	9.5	—	—	—	—
2000	1859	8.6	2001	9.2	2132	9.8	—	—	—	—

CFM	AVAILABLE EXTERNAL STATIC PRESSURE (in. wg)									
	1.2		1.4		1.6		1.8		2.0	
	rpm	vdc	rpm	vdc	rpm	vdc	rpm	vdc	rpm	vdc
1200	2011	9.3	2126	9.8	—	—	—	—	—	—
1300	2061	9.5	—	—	—	—	—	—	—	—
1400	2114	9.7	—	—	—	—	—	—	—	—
1500	—	—	—	—	—	—	—	—	—	—
1600	—	—	—	—	—	—	—	—	—	—
1700	—	—	—	—	—	—	—	—	—	—
1800	—	—	—	—	—	—	—	—	—	—
1900	—	—	—	—	—	—	—	—	—	—
2000	—	—	—	—	—	—	—	—	—	—

Medium Static 1262-2170 rpm

NOTE: Fan tables include highest gas heat. Utilize static pressure deduction tables on page 39 for lower gas heat capacities.

48GCFJ05 Three Phase — High Static — 4 Ton Vertical Supply (rpm - vdc)

CFM	AVAILABLE EXTERNAL STATIC PRESSURE (in. wg)									
	0.2		0.4		0.6		0.8		1.0	
	rpm	vdc	rpm	vdc	rpm	vdc	rpm	vdc	rpm	vdc
1200	1262	4.7	1452	5.5	1614	6.1	1757	6.6	1888	7.1
1300	1333	5.0	1516	5.7	1674	6.3	1813	6.8	1942	7.3
1400	1405	5.3	1583	6.0	1735	6.5	1872	7.0	1997	7.5
1500	1478	5.6	1650	6.2	1798	6.8	1932	7.3	2054	7.7
1600	1552	5.8	1718	6.5	1863	7.0	1993	7.5	2114	7.9
1700	1627	6.1	1787	6.7	1928	7.2	2057	7.7	2174	8.2
1800	1704	6.4	1857	7.0	1995	7.5	2121	8.0	2236	8.4
1900	1781	6.7	1929	7.3	2063	7.8	2185	8.2	2299	8.6
2000	1859	7.0	2001	7.5	2132	8.0	2252	8.5	2363	8.9

CFM	AVAILABLE EXTERNAL STATIC PRESSURE (in. wg)									
	1.2		1.4		1.6		1.8		2.0	
	rpm	vdc	rpm	vdc	rpm	vdc	rpm	vdc	rpm	vdc
1200	2011	7.6	2126	8.0	2236	8.4	2341	8.8	2442	9.2
1300	2061	7.7	2174	8.2	2281	8.6	2384	9.0	2482	9.3
1400	2114	7.9	2224	8.4	2329	8.8	2429	9.1	2526	9.5
1500	2169	8.2	2277	8.6	2379	8.9	2477	9.3	2572	9.7
1600	2226	8.4	2331	8.8	2432	9.1	2528	9.5	2621	9.9
1700	2284	8.6	2388	9.0	2486	9.3	2581	9.7	—	—
1800	2344	8.8	2446	9.2	2543	9.6	2623	9.9	—	—
1900	2405	9.0	2505	9.4	2600	9.8	—	—	—	—
2000	2467	9.3	2565	9.6	2659	10.0	—	—	—	—

High Static 1262-2660 rpm

NOTE: Fan tables include highest gas heat. Utilize static pressure deduction tables on page 39 for lower gas heat capacities.

48GCFT06 Single Phase — 5 Ton Vertical Supply (rpm - bhp)

CFM	AVAILABLE EXTERNAL STATIC PRESSURE (in. wg)									
	0.2		0.4		0.6		0.8		1.0	
	rpm	bhp	rpm	bhp	rpm	bhp	rpm	bhp	rpm	bhp
1500	1387	0.28	1561	0.40	1711	0.53	1845	0.66	1966	0.80
1625	1473	0.34	1638	0.46	1784	0.60	1914	0.74	2034	0.89
1750	1560	0.40	1717	0.53	1859	0.68	1986	0.83	2103	0.98
1875	1650	0.47	1798	0.61	1935	0.77	2059	0.92	2174	1.08
2000	1741	0.56	1881	0.70	2012	0.86	2134	1.03	2246	1.20
2125	1832	0.65	1965	0.80	2091	0.97	2209	1.14	2320	1.32
2250	1925	0.75	2050	0.91	2172	1.08	2286	1.26	—	—
2375	2018	0.87	2137	1.03	2254	1.21	2365	1.40	—	—
2500	2113	1.00	2225	1.16	2337	1.35	—	—	—	—

CFM	AVAILABLE EXTERNAL STATIC PRESSURE (in. wg)									
	1.2		1.4		1.6		1.8		2.0	
	rpm	bhp	rpm	bhp	rpm	bhp	rpm	bhp	rpm	bhp
1500	2079	0.95	2185	1.10	2285	1.26	2381	1.43	—	—
1625	2144	1.04	2248	1.20	2346	1.36	—	—	—	—
1750	2211	1.14	2313	1.31	—	—	—	—	—	—
1875	2281	1.25	2380	1.42	—	—	—	—	—	—
2000	2351	1.37	—	—	—	—	—	—	—	—
2125	—	—	—	—	—	—	—	—	—	—
2250	—	—	—	—	—	—	—	—	—	—
2375	—	—	—	—	—	—	—	—	—	—
2500	—	—	—	—	—	—	—	—	—	—

Standard Static 1387-2150 rpm, 1.06 max bhp

Medium Static 1387-2390 rpm, 1.44 max bhp

NOTE: Fan tables include highest gas heat. Utilize static pressure deduction tables on page 39 for lower gas heat capacities.

48GCFT06 Single Phase — Standard Static — 5 Ton Vertical Supply (rpm - vdc)

CFM	AVAILABLE EXTERNAL STATIC PRESSURE (in. wg)									
	0.2		0.4		0.6		0.8		1.0	
	rpm	vdc	rpm	vdc	rpm	vdc	rpm	vdc	rpm	vdc
1500	1387	6.5	1561	7.3	1711	8.0	1845	8.6	1966	9.1
1625	1473	6.9	1638	7.6	1784	8.3	1914	8.9	2034	9.5
1750	1560	7.3	1717	8.0	1859	8.6	1986	9.2	2103	9.8
1875	1650	7.7	1798	8.4	1935	9.0	2059	9.6	—	—
2000	1741	8.1	1881	8.7	2012	9.4	2134	9.9	—	—
2125	1832	8.5	1965	9.1	2091	9.7	—	—	—	—
2250	1925	9.0	2050	9.5	—	—	—	—	—	—
2375	2018	9.4	2137	9.9	—	—	—	—	—	—
2500	2113	9.8	—	—	—	—	—	—	—	—

CFM	AVAILABLE EXTERNAL STATIC PRESSURE (in. wg)									
	1.2		1.4		1.6		1.8		2.0	
	rpm	vdc	rpm	vdc	rpm	vdc	rpm	vdc	rpm	vdc
1500	2079	9.7	—	—	—	—	—	—	—	—
1625	2144	10.0	—	—	—	—	—	—	—	—
1750	—	—	—	—	—	—	—	—	—	—
1875	—	—	—	—	—	—	—	—	—	—
2000	—	—	—	—	—	—	—	—	—	—
2125	—	—	—	—	—	—	—	—	—	—
2250	—	—	—	—	—	—	—	—	—	—
2375	—	—	—	—	—	—	—	—	—	—
2500	—	—	—	—	—	—	—	—	—	—

Standard Static 1387-2150 rpm

NOTE: Fan tables include highest gas heat. Utilize static pressure deduction tables on page 39 for lower gas heat capacities.

48GCFT06 Single Phase — Medium Static — 5 Ton Vertical Supply (rpm - vdc)

CFM	AVAILABLE EXTERNAL STATIC PRESSURE (in. wg)									
	0.2		0.4		0.6		0.8		1.0	
	rpm	vdc	rpm	vdc	rpm	vdc	rpm	vdc	rpm	vdc
1500	1387	5.8	1561	6.5	1711	7.2	1845	7.7	1966	8.2
1625	1473	6.2	1638	6.9	1784	7.5	1914	8.0	2034	8.5
1750	1560	6.5	1717	7.2	1859	7.8	1986	8.3	2103	8.8
1875	1650	6.9	1798	7.5	1935	8.1	2059	8.6	2174	9.1
2000	1741	7.3	1881	7.9	2012	8.4	2134	8.9	2246	9.4
2125	1832	7.7	1965	8.2	2091	8.7	2209	9.2	2320	9.7
2250	1925	8.1	2050	8.6	2172	9.1	2286	9.6	—	—
2375	2018	8.4	2137	8.9	2254	9.4	2365	9.9	—	—
2500	2113	8.8	2225	9.3	2337	9.8	—	—	—	—

CFM	AVAILABLE EXTERNAL STATIC PRESSURE (in. wg)									
	1.2		1.4		1.6		1.8		2.0	
	rpm	vdc	rpm	vdc	rpm	vdc	rpm	vdc	rpm	vdc
1500	2079	8.7	2185	9.1	2285	9.6	2381	10.0	—	—
1625	2144	9.0	2248	9.4	2346	9.8	—	—	—	—
1750	2211	9.3	2313	9.7	—	—	—	—	—	—
1875	2281	9.5	2380	10.0	—	—	—	—	—	—
2000	2351	9.8	—	—	—	—	—	—	—	—
2125	—	—	—	—	—	—	—	—	—	—
2250	—	—	—	—	—	—	—	—	—	—
2375	—	—	—	—	—	—	—	—	—	—
2500	—	—	—	—	—	—	—	—	—	—

Medium Static 1387-2390 rpm

NOTE: Fan tables include highest gas heat. Utilize static pressure deduction tables on page 39 for lower gas heat capacities.

48GCFJ06 Three Phase — 5 Ton Vertical Supply (rpm - bhp)

CFM	AVAILABLE EXTERNAL STATIC PRESSURE (in. wg)									
	0.2		0.4		0.6		0.8		1.0	
	rpm	bhp	rpm	bhp	rpm	bhp	rpm	bhp	rpm	bhp
1500	1387	0.28	1560	0.40	1711	0.53	1845	0.66	1966	0.80
1625	1473	0.34	1638	0.46	1784	0.60	1915	0.74	2034	0.89
1750	1561	0.40	1717	0.53	1858	0.68	1986	0.83	2103	0.98
1875	1650	0.47	1798	0.61	1934	0.76	2059	0.92	2174	1.08
2000	1741	0.56	1881	0.70	2012	0.86	2133	1.02	2246	1.20
2125	1832	0.65	1965	0.80	2091	0.97	2209	1.14	2319	1.32
2250	1925	0.75	2050	0.91	2172	1.08	2286	1.26	2394	1.45
2375	2018	0.87	2137	1.03	2254	1.21	2364	1.40	2469	1.59
2500	2113	1.00	2225	1.16	2337	1.35	2444	1.54	2547	1.75

CFM	AVAILABLE EXTERNAL STATIC PRESSURE (in. wg)									
	1.2		1.4		1.6		1.8		2.0	
	rpm	bhp	rpm	bhp	rpm	bhp	rpm	bhp	rpm	bhp
1500	2079	0.95	2185	1.10	2285	1.26	2381	1.43	2473	1.60
1625	2144	1.04	2248	1.20	2346	1.36	2440	1.53	2530	1.71
1750	2212	1.14	2313	1.31	2410	1.48	2502	1.65	2590	1.83
1875	2281	1.25	2381	1.43	2475	1.60	2566	1.78	2653	1.97
2000	2351	1.37	2449	1.55	2543	1.74	2632	1.93	2717	2.12
2125	2422	1.50	2519	1.69	2611	1.88	2699	2.08	2783	2.28
2250	2495	1.64	2590	1.84	2681	2.04	2767	2.24	—	—
2375	2569	1.79	2663	2.00	2752	2.20	—	—	—	—
2500	2643	1.95	2736	2.17	2824	2.38	—	—	—	—

- Standard Static 1387-2150 rpm, 1.06 max bhp
- Medium Static 1387-2390 rpm, 1.44 max bhp
- High Static 1387-2836 rpm, 2.43 max bhp

NOTE: Fan tables include highest gas heat. Utilize static pressure deduction tables on page 39 for lower gas heat capacities.

48GCFJ06 Three Phase — Standard Static — 5 Ton Vertical Supply (rpm - vdc)

CFM	AVAILABLE EXTERNAL STATIC PRESSURE (in. wg)									
	0.2		0.4		0.6		0.8		1.0	
	rpm	vdc	rpm	vdc	rpm	vdc	rpm	vdc	rpm	vdc
1500	1387	6.5	1560	7.3	1711	8.0	1845	8.6	1966	9.1
1625	1473	6.9	1638	7.6	1784	8.3	1915	8.9	2034	9.5
1750	1561	7.3	1717	8.0	1858	8.6	1986	9.2	2103	9.8
1875	1650	7.7	1798	8.4	1934	9.0	2059	9.6	—	—
2000	1741	8.1	1881	8.7	2012	9.4	2133	9.9	—	—
2125	1832	8.5	1965	9.1	2091	9.7	—	—	—	—
2250	1925	9.0	2050	9.5	—	—	—	—	—	—
2375	2018	9.4	2137	9.9	—	—	—	—	—	—
2500	2113	9.8	—	—	—	—	—	—	—	—

CFM	AVAILABLE EXTERNAL STATIC PRESSURE (in. wg)									
	1.2		1.4		1.6		1.8		2.0	
	rpm	vdc	rpm	vdc	rpm	vdc	rpm	vdc	rpm	vdc
1500	2079	9.7	—	—	—	—	—	—	—	—
1625	2144	10.0	—	—	—	—	—	—	—	—
1750	—	—	—	—	—	—	—	—	—	—
1875	—	—	—	—	—	—	—	—	—	—
2000	—	—	—	—	—	—	—	—	—	—
2125	—	—	—	—	—	—	—	—	—	—
2250	—	—	—	—	—	—	—	—	—	—
2375	—	—	—	—	—	—	—	—	—	—
2500	—	—	—	—	—	—	—	—	—	—

- Standard Static 1387-2150 rpm

NOTE: Fan tables include highest gas heat. Utilize static pressure deduction tables on page 39 for lower gas heat capacities.

48GCFJ06 Three Phase — Medium Static — 5 Ton Vertical Supply (rpm - vdc)

CFM	AVAILABLE EXTERNAL STATIC PRESSURE (in. wg)									
	0.2		0.4		0.6		0.8		1.0	
	rpm	vdc	rpm	vdc	rpm	vdc	rpm	vdc	rpm	vdc
1500	1387	5.8	1560	6.5	1711	7.2	1845	7.7	1966	8.2
1625	1473	6.2	1638	6.9	1784	7.5	1915	8.0	2034	8.5
1750	1561	6.5	1717	7.2	1858	7.8	1986	8.3	2103	8.8
1875	1650	6.9	1798	7.5	1934	8.1	2059	8.6	2174	9.1
2000	1741	7.3	1881	7.9	2012	8.4	2133	8.9	2246	9.4
2125	1832	7.7	1965	8.2	2091	8.7	2209	9.2	2319	9.7
2250	1925	8.1	2050	8.6	2172	9.1	2286	9.6	—	—
2375	2018	8.4	2137	8.9	2254	9.4	2364	9.9	—	—
2500	2113	8.8	2225	9.3	2337	9.8	—	—	—	—

CFM	AVAILABLE EXTERNAL STATIC PRESSURE (in. wg)									
	1.2		1.4		1.6		1.8		2.0	
	rpm	vdc	rpm	vdc	rpm	vdc	rpm	vdc	rpm	vdc
1500	2079	8.7	2185	9.1	2285	9.6	2381	10.0	—	—
1625	2144	9.0	2248	9.4	2346	9.8	—	—	—	—
1750	2212	9.3	2313	9.7	—	—	—	—	—	—
1875	2281	9.5	2381	10.0	—	—	—	—	—	—
2000	2351	9.8	—	—	—	—	—	—	—	—
2125	—	—	—	—	—	—	—	—	—	—
2250	—	—	—	—	—	—	—	—	—	—
2375	—	—	—	—	—	—	—	—	—	—
2500	—	—	—	—	—	—	—	—	—	—

Medium Static 1387-2390 rpm

NOTE: Fan tables include highest gas heat. Utilize static pressure deduction tables on page 39 for lower gas heat capacities.

48GCFJ06 Three Phase — High Static — 5 Ton Vertical Supply (rpm - vdc)

CFM	AVAILABLE EXTERNAL STATIC PRESSURE (in. wg)									
	0.2		0.4		0.6		0.8		1.0	
	rpm	vdc	rpm	vdc	rpm	vdc	rpm	vdc	rpm	vdc
1500	1387	4.9	1560	5.5	1711	6.0	1845	6.5	1966	6.9
1625	1473	5.2	1638	5.8	1784	6.3	1915	6.8	2034	7.2
1750	1561	5.5	1717	6.1	1858	6.6	1986	7.0	2103	7.4
1875	1650	5.8	1798	6.3	1934	6.8	2059	7.3	2174	7.7
2000	1741	6.1	1881	6.6	2012	7.1	2133	7.5	2246	7.9
2125	1832	6.5	1965	6.9	2091	7.4	2209	7.8	2319	8.2
2250	1925	6.8	2050	7.2	2172	7.7	2286	8.1	2394	8.4
2375	2018	7.1	2137	7.5	2254	7.9	2364	8.3	2469	8.7
2500	2113	7.5	2225	7.8	2337	8.2	2444	8.6	2547	9.0

CFM	AVAILABLE EXTERNAL STATIC PRESSURE (in. wg)									
	1.2		1.4		1.6		1.8		2.0	
	rpm	vdc	rpm	vdc	rpm	vdc	rpm	vdc	rpm	vdc
1500	2079	7.3	2185	7.7	2285	8.1	2381	8.4	2473	8.7
1625	2144	7.6	2248	7.9	2346	8.3	2440	8.6	2530	8.9
1750	2212	7.8	2313	8.2	2410	8.5	2502	8.8	2590	9.1
1875	2281	8.0	2381	8.4	2475	8.7	2566	9.0	2653	9.4
2000	2351	8.3	2449	8.6	2543	9.0	2632	9.3	2717	9.6
2125	2422	8.5	2519	8.9	2611	9.2	2699	9.5	2783	9.8
2250	2495	8.8	2590	9.1	2681	9.5	2767	9.8	—	—
2375	2569	9.1	2663	9.4	2752	9.7	—	—	—	—
2500	2643	9.3	2736	9.6	2824	10.0	—	—	—	—

High Static 1387-2836 rpm

NOTE: Fan tables include highest gas heat. Utilize static pressure deduction tables on page 39 for lower gas heat capacities.

48GCET04 Single Phase — 3 Ton Horizontal Supply (rpm - bhp)

CFM	AVAILABLE EXTERNAL STATIC PRESSURE (in. wg)									
	0.2		0.4		0.6		0.8		1.0	
	rpm	bhp	rpm	bhp	rpm	bhp	rpm	bhp	rpm	bhp
900	1097	0.09	1331	0.16	1524	0.25	1692	0.34	1842	0.44
975	1146	0.10	1373	0.18	1562	0.27	1728	0.36	1877	0.46
1050	1197	0.12	1416	0.20	1601	0.29	1765	0.38	1912	0.49
1125	1249	0.14	1460	0.22	1642	0.31	1803	0.41	1949	0.52
1200	1303	0.15	1506	0.24	1684	0.33	1842	0.44	1986	0.55
1275	1359	0.17	1553	0.26	1727	0.36	1883	0.46	2025	0.58
1350	1415	0.20	1602	0.29	1771	0.39	1925	0.50	2064	0.61
1425	1472	0.22	1652	0.31	1817	0.42	1967	0.53	2105	0.65
1500	1530	0.25	1703	0.34	1863	0.45	2010	0.57	2147	0.69

CFM	AVAILABLE EXTERNAL STATIC PRESSURE (in. wg)									
	1.2		1.4		1.6		1.8		2.0	
	rpm	bhp	rpm	bhp	rpm	bhp	rpm	bhp	rpm	bhp
900	1980	0.54	2107	0.65	2225	0.77	2337	0.89	2443	1.02
975	2013	0.57	2139	0.68	2258	0.80	2369	0.93	2475	1.06
1050	2048	0.60	2173	0.71	2291	0.84	2401	0.96	—	—
1125	2083	0.63	2207	0.75	2324	0.87	2435	1.01	—	—
1200	2119	0.66	2242	0.78	2359	0.91	2468	1.05	—	—
1275	2156	0.70	2278	0.82	2394	0.96	—	—	—	—
1350	2194	0.74	2315	0.86	2429	1.00	—	—	—	—
1425	2233	0.78	2353	0.91	2466	1.04	—	—	—	—
1500	2273	0.82	2391	0.95	—	—	—	—	—	—

- Standard Static 1097-1890 rpm, 0.44 max bhp
- Medium Static 1097-2190 rpm, 0.71 max bhp
- High Static 1097-2490 rpm, 1.07 max bhp

NOTE: Fan tables include highest gas heat. Utilize static pressure deduction tables on page 39 for lower gas heat capacities.

48GCET04 Single Phase — Standard Static — 3 Ton Horizontal Supply (rpm - vdc)

CFM	AVAILABLE EXTERNAL STATIC PRESSURE (in. wg)									
	0.2		0.4		0.6		0.8		1.0	
	rpm	vdc	rpm	vdc	rpm	vdc	rpm	vdc	rpm	vdc
900	1097	5.8	1331	7.0	1524	8.1	1692	9.0	1842	9.7
975	1146	6.1	1373	7.3	1562	8.3	1728	9.1	—	—
1050	1197	6.3	1416	7.5	1601	8.5	1765	9.3	—	—
1125	1249	6.6	1460	7.7	1642	8.7	1803	9.5	—	—
1200	1303	6.9	1506	8.0	1684	8.9	1842	9.7	—	—
1275	1359	7.2	1553	8.2	1727	9.1	—	—	—	—
1350	1415	7.5	1602	8.5	1771	9.4	—	—	—	—
1425	1472	7.8	1652	8.7	1817	9.6	—	—	—	—
1500	1530	8.1	1703	9.0	—	—	—	—	—	—

CFM	AVAILABLE EXTERNAL STATIC PRESSURE (in. wg)									
	1.2		1.4		1.6		1.8		2.0	
	rpm	vdc	rpm	vdc	rpm	vdc	rpm	vdc	rpm	vdc
900	—	—	—	—	—	—	—	—	—	—
975	—	—	—	—	—	—	—	—	—	—
1050	—	—	—	—	—	—	—	—	—	—
1125	—	—	—	—	—	—	—	—	—	—
1200	—	—	—	—	—	—	—	—	—	—
1275	—	—	—	—	—	—	—	—	—	—
1350	—	—	—	—	—	—	—	—	—	—
1425	—	—	—	—	—	—	—	—	—	—
1500	—	—	—	—	—	—	—	—	—	—

- Standard Static 1097-1890 rpm

NOTE: Fan tables include highest gas heat. Utilize static pressure deduction tables on page 39 for lower gas heat capacities.

48GCET04 Single Phase — Medium Static — 3 Ton Horizontal Supply (rpm - vdc)

CFM	AVAILABLE EXTERNAL STATIC PRESSURE (in. wg)									
	0.2		0.4		0.6		0.8		1.0	
	rpm	vdc	rpm	vdc	rpm	vdc	rpm	vdc	rpm	vdc
900	1097	5.0	1331	6.1	1524	7.0	1692	7.7	1842	8.4
975	1146	5.2	1373	6.3	1562	7.1	1728	7.9	1877	8.6
1050	1197	5.5	1416	6.5	1601	7.3	1765	8.1	1912	8.7
1125	1249	5.7	1460	6.7	1642	7.5	1803	8.2	1949	8.9
1200	1303	5.9	1506	6.9	1684	7.7	1842	8.4	1986	9.1
1275	1359	6.2	1553	7.1	1727	7.9	1883	8.6	2025	9.2
1350	1415	6.5	1602	7.3	1771	8.1	1925	8.8	2064	9.4
1425	1472	6.7	1652	7.5	1817	8.3	1967	9.0	2105	9.6
1500	1530	7.0	1703	7.8	1863	8.5	2010	9.2	2147	9.8

CFM	AVAILABLE EXTERNAL STATIC PRESSURE (in. wg)									
	1.2		1.4		1.6		1.8		2.0	
	rpm	vdc	rpm	vdc	rpm	vdc	rpm	vdc	rpm	vdc
900	1980	9.0	2107	9.6	—	—	—	—	—	—
975	2013	9.2	2139	9.8	—	—	—	—	—	—
1050	2048	9.4	2173	9.9	—	—	—	—	—	—
1125	2083	9.5	—	—	—	—	—	—	—	—
1200	2119	9.7	—	—	—	—	—	—	—	—
1275	2156	9.8	—	—	—	—	—	—	—	—
1350	—	—	—	—	—	—	—	—	—	—
1425	—	—	—	—	—	—	—	—	—	—
1500	—	—	—	—	—	—	—	—	—	—

Medium Static 1097-2190 rpm

NOTE: Fan tables include highest gas heat. Utilize static pressure deduction tables on page 39 for lower gas heat capacities.

48GCET04 Single Phase — High Static — 3 Ton Horizontal Supply (rpm - vdc)

CFM	AVAILABLE EXTERNAL STATIC PRESSURE (in. wg)									
	0.2		0.4		0.6		0.8		1.0	
	rpm	vdc	rpm	vdc	rpm	vdc	rpm	vdc	rpm	vdc
900	1097	4.4	1331	5.3	1524	6.1	1692	6.8	1842	7.4
975	1146	4.6	1373	5.5	1562	6.3	1728	6.9	1877	7.5
1050	1197	4.8	1416	5.7	1601	6.4	1765	7.1	1912	7.7
1125	1249	5.0	1460	5.9	1642	6.6	1803	7.2	1949	7.8
1200	1303	5.2	1506	6.0	1684	6.8	1842	7.4	1986	8.0
1275	1359	5.5	1553	6.2	1727	6.9	1883	7.6	2025	8.1
1350	1415	5.7	1602	6.4	1771	7.1	1925	7.7	2064	8.3
1425	1472	5.9	1652	6.6	1817	7.3	1967	7.9	2105	8.5
1500	1530	6.1	1703	6.8	1863	7.5	2010	8.1	2147	8.6

CFM	AVAILABLE EXTERNAL STATIC PRESSURE (in. wg)									
	1.2		1.4		1.6		1.8		2.0	
	rpm	vdc	rpm	vdc	rpm	vdc	rpm	vdc	rpm	vdc
900	1980	8.0	2107	8.5	2225	8.9	2337	9.4	2443	9.8
975	2013	8.1	2139	8.6	2258	9.1	2369	9.5	2475	9.9
1050	2048	8.2	2173	8.7	2291	9.2	2401	9.6	—	—
1125	2083	8.4	2207	8.9	2324	9.3	2435	9.8	—	—
1200	2119	8.5	2242	9.0	2359	9.5	2468	9.9	—	—
1275	2156	8.7	2278	9.1	2394	9.6	—	—	—	—
1350	2194	8.8	2315	9.3	2429	9.8	—	—	—	—
1425	2233	9.0	2353	9.4	2466	9.9	—	—	—	—
1500	2273	9.1	2391	9.6	—	—	—	—	—	—

High Static 1097-2490 rpm

NOTE: Fan tables include highest gas heat. Utilize static pressure deduction tables on page 39 for lower gas heat capacities.

48GCEJ04 Three Phase — 3 Ton Horizontal Supply (rpm - bhp)

CFM	AVAILABLE EXTERNAL STATIC PRESSURE (in. wg)									
	0.2		0.4		0.6		0.8		1.0	
	rpm	bhp	rpm	bhp	rpm	bhp	rpm	bhp	rpm	bhp
900	1097	0.09	1331	0.16	1524	0.25	1692	0.34	1842	0.44
975	1146	0.10	1373	0.18	1562	0.27	1728	0.36	1877	0.46
1050	1197	0.12	1416	0.20	1601	0.29	1765	0.38	1912	0.49
1125	1249	0.14	1460	0.22	1642	0.31	1803	0.41	1949	0.52
1200	1303	0.15	1506	0.24	1684	0.33	1842	0.44	1986	0.55
1275	1359	0.17	1553	0.26	1727	0.36	1883	0.46	2025	0.58
1350	1415	0.20	1602	0.29	1771	0.39	1925	0.50	2064	0.61
1425	1472	0.22	1652	0.31	1817	0.42	1967	0.53	2105	0.65
1500	1530	0.25	1703	0.34	1863	0.45	2010	0.57	2147	0.69

CFM	AVAILABLE EXTERNAL STATIC PRESSURE (in. wg)									
	1.2		1.4		1.6		1.8		2.0	
	rpm	bhp	rpm	bhp	rpm	bhp	rpm	bhp	rpm	bhp
900	1980	0.54	2107	0.65	2225	0.77	2337	0.89	2443	1.02
975	2013	0.57	2139	0.68	2258	0.80	2369	0.93	2475	1.06
1050	2048	0.60	2173	0.71	2291	0.84	2401	0.96	—	—
1125	2083	0.63	2207	0.75	2324	0.87	2435	1.01	—	—
1200	2119	0.66	2242	0.78	2359	0.91	2468	1.05	—	—
1275	2156	0.70	2278	0.82	2394	0.96	—	—	—	—
1350	2194	0.74	2315	0.86	2429	1.00	—	—	—	—
1425	2233	0.78	2353	0.91	2466	1.04	—	—	—	—
1500	2273	0.82	2391	0.95	—	—	—	—	—	—

Standard Static 1097-1890 rpm, 0.44 max bhp

Medium Static 1097-2190 rpm, 0.71 max bhp

High Static 1097-2490 rpm, 1.07 max bhp

NOTE: Fan tables include highest gas heat. Utilize static pressure deduction tables on page 39 for lower gas heat capacities.

48GCEJ04 Three Phase — Standard Static — 3 Ton Horizontal Supply (rpm - vdc)

CFM	AVAILABLE EXTERNAL STATIC PRESSURE (in. wg)									
	0.2		0.4		0.6		0.8		1.0	
	rpm	vdc	rpm	vdc	rpm	vdc	rpm	vdc	rpm	vdc
900	1097	5.8	1331	7.0	1524	8.1	1692	9.0	1842	9.7
975	1146	6.1	1373	7.3	1562	8.3	1728	9.1	—	—
1050	1197	6.3	1416	7.5	1601	8.5	1765	9.3	—	—
1125	1249	6.6	1460	7.7	1642	8.7	1803	9.5	—	—
1200	1303	6.9	1506	8.0	1684	8.9	1842	9.7	—	—
1275	1359	7.2	1553	8.2	1727	9.1	—	—	—	—
1350	1415	7.5	1602	8.5	1771	9.4	—	—	—	—
1425	1472	7.8	1652	8.7	1817	9.6	—	—	—	—
1500	1530	8.1	1703	9.0	—	—	—	—	—	—

CFM	AVAILABLE EXTERNAL STATIC PRESSURE (in. wg)									
	1.2		1.4		1.6		1.8		2.0	
	rpm	vdc	rpm	vdc	rpm	vdc	rpm	vdc	rpm	vdc
900	—	—	—	—	—	—	—	—	—	—
975	—	—	—	—	—	—	—	—	—	—
1050	—	—	—	—	—	—	—	—	—	—
1125	—	—	—	—	—	—	—	—	—	—
1200	—	—	—	—	—	—	—	—	—	—
1275	—	—	—	—	—	—	—	—	—	—
1350	—	—	—	—	—	—	—	—	—	—
1425	—	—	—	—	—	—	—	—	—	—
1500	—	—	—	—	—	—	—	—	—	—

Standard Static 1097-1890 rpm

NOTE: Fan tables include highest gas heat. Utilize static pressure deduction tables on page 39 for lower gas heat capacities.

48GCEJ04 Three Phase — Medium Static — 3 Ton Horizontal Supply (rpm - vdc)

CFM	AVAILABLE EXTERNAL STATIC PRESSURE (in. wg)									
	0.2		0.4		0.6		0.8		1.0	
	rpm	vdc	rpm	vdc	rpm	vdc	rpm	vdc	rpm	vdc
900	1097	5.0	1331	6.1	1524	7.0	1692	7.7	1842	8.4
975	1146	5.2	1373	6.3	1562	7.1	1728	7.9	1877	8.6
1050	1197	5.5	1416	6.5	1601	7.3	1765	8.1	1912	8.7
1125	1249	5.7	1460	6.7	1642	7.5	1803	8.2	1949	8.9
1200	1303	5.9	1506	6.9	1684	7.7	1842	8.4	1986	9.1
1275	1359	6.2	1553	7.1	1727	7.9	1883	8.6	2025	9.2
1350	1415	6.5	1602	7.3	1771	8.1	1925	8.8	2064	9.4
1425	1472	6.7	1652	7.5	1817	8.3	1967	9.0	2105	9.6
1500	1530	7.0	1703	7.8	1863	8.5	2010	9.2	2147	9.8

CFM	AVAILABLE EXTERNAL STATIC PRESSURE (in. wg)									
	1.2		1.4		1.6		1.8		2.0	
	rpm	vdc	rpm	vdc	rpm	vdc	rpm	vdc	rpm	vdc
900	1980	9.0	2107	9.6	—	—	—	—	—	—
975	2013	9.2	2139	9.8	—	—	—	—	—	—
1050	2048	9.4	2173	9.9	—	—	—	—	—	—
1125	2083	9.5	—	—	—	—	—	—	—	—
1200	2119	9.7	—	—	—	—	—	—	—	—
1275	2156	9.8	—	—	—	—	—	—	—	—
1350	—	—	—	—	—	—	—	—	—	—
1425	—	—	—	—	—	—	—	—	—	—
1500	—	—	—	—	—	—	—	—	—	—

Medium Static 1097-2190 rpm

NOTE: Fan tables include highest gas heat. Utilize static pressure deduction tables on page 39 for lower gas heat capacities.

48GCEJ04 Three Phase — High Static — 3 Ton Horizontal Supply (rpm - vdc)

CFM	AVAILABLE EXTERNAL STATIC PRESSURE (in. wg)									
	0.2		0.4		0.6		0.8		1.0	
	rpm	vdc	rpm	vdc	rpm	vdc	rpm	vdc	rpm	vdc
900	1097	4.4	1331	5.3	1524	6.1	1692	6.8	1842	7.4
975	1146	4.6	1373	5.5	1562	6.3	1728	6.9	1877	7.5
1050	1197	4.8	1416	5.7	1601	6.4	1765	7.1	1912	7.7
1125	1249	5.0	1460	5.9	1642	6.6	1803	7.2	1949	7.8
1200	1303	5.2	1506	6.0	1684	6.8	1842	7.4	1986	8.0
1275	1359	5.5	1553	6.2	1727	6.9	1883	7.6	2025	8.1
1350	1415	5.7	1602	6.4	1771	7.1	1925	7.7	2064	8.3
1425	1472	5.9	1652	6.6	1817	7.3	1967	7.9	2105	8.5
1500	1530	6.1	1703	6.8	1863	7.5	2010	8.1	2147	8.6

CFM	AVAILABLE EXTERNAL STATIC PRESSURE (in. wg)									
	1.2		1.4		1.6		1.8		2.0	
	rpm	vdc	rpm	vdc	rpm	vdc	rpm	vdc	rpm	vdc
900	1980	8.0	2107	8.5	2225	8.9	2337	9.4	2443	9.8
975	2013	8.1	2139	8.6	2258	9.1	2369	9.5	2475	9.9
1050	2048	8.2	2173	8.7	2291	9.2	2401	9.6	—	—
1125	2083	8.4	2207	8.9	2324	9.3	2435	9.8	—	—
1200	2119	8.5	2242	9.0	2359	9.5	2468	9.9	—	—
1275	2156	8.7	2278	9.1	2394	9.6	—	—	—	—
1350	2194	8.8	2315	9.3	2429	9.8	—	—	—	—
1425	2233	9.0	2353	9.4	2466	9.9	—	—	—	—
1500	2273	9.1	2391	9.6	—	—	—	—	—	—

High Static 1097-2490 rpm

NOTE: Fan tables include highest gas heat. Utilize static pressure deduction tables on page 39 for lower gas heat capacities.

48GCFT05 Single Phase — 4 Ton Horizontal Supply (rpm - bhp)

CFM	AVAILABLE EXTERNAL STATIC PRESSURE (in. wg)									
	0.2		0.4		0.6		0.8		1.0	
	rpm	bhp	rpm	bhp	rpm	bhp	rpm	bhp	rpm	bhp
1200	1217	0.19	1411	0.30	1576	0.42	1722	0.55	1855	0.68
1300	1283	0.23	1470	0.34	1631	0.46	1774	0.60	1904	0.74
1400	1351	0.26	1531	0.38	1688	0.51	1827	0.65	1955	0.80
1500	1420	0.31	1593	0.43	1746	0.57	1883	0.71	2008	0.86
1600	1491	0.35	1657	0.48	1805	0.63	1939	0.78	2062	0.93
1700	1563	0.41	1722	0.54	1866	0.69	1997	0.85	2118	1.01
1800	1635	0.46	1789	0.61	1928	0.76	2056	0.92	2174	1.09
1900	1709	0.53	1856	0.68	1991	0.84	2116	1.01	2232	1.18
2000	1784	0.60	1925	0.76	2056	0.92	2178	1.10	2291	1.28

CFM	AVAILABLE EXTERNAL STATIC PRESSURE (in. wg)									
	1.2		1.4		1.6		1.8		2.0	
	rpm	bhp	rpm	bhp	rpm	bhp	rpm	bhp	rpm	bhp
1200	1978	0.83	2094	0.98	2204	1.15	2308	1.32	2409	1.50
1300	2025	0.89	2138	1.05	2246	1.21	2349	1.39	2447	1.57
1400	2074	0.95	2185	1.11	2291	1.28	2391	1.46	—	—
1500	2124	1.02	2234	1.19	2338	1.36	2436	1.54	—	—
1600	2176	1.10	2284	1.27	2386	1.45	—	—	—	—
1700	2230	1.18	2336	1.36	2436	1.54	—	—	—	—
1800	2285	1.27	2389	1.45	—	—	—	—	—	—
1900	2341	1.36	2444	1.55	—	—	—	—	—	—
2000	2398	1.46	—	—	—	—	—	—	—	—

- Standard Static 1217-1900 rpm, 0.72 max bhp
- Medium Static 1217-2170 rpm, 1.06 max bhp
- High Static 1217-2460 rpm, 1.53, max bhp

NOTE: Fan tables include highest gas heat. Utilize static pressure deduction tables on page 39 for lower gas heat capacities.

48GCFT05 Single Phase — Standard Static — 4 Ton Horizontal Supply (rpm - vdc)

CFM	AVAILABLE EXTERNAL STATIC PRESSURE (in. wg)									
	0.2		0.4		0.6		0.8		1.0	
	rpm	vdc	rpm	vdc	rpm	vdc	rpm	vdc	rpm	vdc
1200	1217	6.4	1411	7.4	1576	8.3	1722	9.1	1855	9.8
1300	1283	6.8	1470	7.7	1631	8.6	1774	9.3	—	—
1400	1351	7.1	1531	8.1	1688	8.9	1827	9.6	—	—
1500	1420	7.5	1593	8.4	1746	9.2	1883	9.9	—	—
1600	1491	7.8	1657	8.7	1805	9.5	—	—	—	—
1700	1563	8.2	1722	9.1	1866	9.8	—	—	—	—
1800	1635	8.6	1789	9.4	—	—	—	—	—	—
1900	1709	9.0	1856	9.8	—	—	—	—	—	—
2000	1784	9.4	—	—	—	—	—	—	—	—

CFM	AVAILABLE EXTERNAL STATIC PRESSURE (in. wg)									
	1.2		1.4		1.6		1.8		2.0	
	rpm	vdc	rpm	vdc	rpm	vdc	rpm	vdc	rpm	vdc
1200	—	—	—	—	—	—	—	—	—	—
1300	—	—	—	—	—	—	—	—	—	—
1400	—	—	—	—	—	—	—	—	—	—
1500	—	—	—	—	—	—	—	—	—	—
1600	—	—	—	—	—	—	—	—	—	—
1700	—	—	—	—	—	—	—	—	—	—
1800	—	—	—	—	—	—	—	—	—	—
1900	—	—	—	—	—	—	—	—	—	—
2000	—	—	—	—	—	—	—	—	—	—

- Standard Static 1217-1990 rpm

NOTE: Fan tables include highest gas heat. Utilize static pressure deduction tables on page 39 for lower gas heat capacities.

48GCFT05 Single Phase — Medium Static — 4 Ton Horizontal Supply (rpm - vdc)

CFM	AVAILABLE EXTERNAL STATIC PRESSURE (in. wg)									
	0.2		0.4		0.6		0.8		1.0	
	rpm	vdc	rpm	vdc	rpm	vdc	rpm	vdc	rpm	vdc
1200	1217	5.6	1411	6.5	1576	7.3	1722	7.9	1855	8.5
1300	1283	5.9	1470	6.8	1631	7.5	1774	8.2	1904	8.8
1400	1351	6.2	1531	7.1	1688	7.8	1827	8.4	1955	9.0
1500	1420	6.5	1593	7.3	1746	8.0	1883	8.7	2008	9.3
1600	1491	6.9	1657	7.6	1805	8.3	1939	8.9	2062	9.5
1700	1563	7.2	1722	7.9	1866	8.6	1997	9.2	2118	9.8
1800	1635	7.5	1789	8.2	1928	8.9	2056	9.5	—	—
1900	1709	7.9	1856	8.6	1991	9.2	2116	9.8	—	—
2000	1784	8.2	1925	8.9	2056	9.5	—	—	—	—

CFM	AVAILABLE EXTERNAL STATIC PRESSURE (in. wg)									
	1.2		1.4		1.6		1.8		2.0	
	rpm	vdc	rpm	vdc	rpm	vdc	rpm	vdc	rpm	vdc
1200	1978	9.1	2094	9.6	—	—	—	—	—	—
1300	2025	9.3	2138	9.9	—	—	—	—	—	—
1400	2074	9.6	—	—	—	—	—	—	—	—
1500	2124	9.8	—	—	—	—	—	—	—	—
1600	—	—	—	—	—	—	—	—	—	—
1700	—	—	—	—	—	—	—	—	—	—
1800	—	—	—	—	—	—	—	—	—	—
1900	—	—	—	—	—	—	—	—	—	—
2000	—	—	—	—	—	—	—	—	—	—

Medium Static 1217-2170 rpm, 1.06 max bhp

NOTE: Fan tables include highest gas heat. Utilize static pressure deduction tables on page 39 for lower gas heat capacities.

48GCFT05 Single Phase — High Static — 4 Ton Horizontal Supply (rpm - vdc)

CFM	AVAILABLE EXTERNAL STATIC PRESSURE (in. wg)									
	0.2		0.4		0.6		0.8		1.0	
	rpm	vdc	rpm	vdc	rpm	vdc	rpm	vdc	rpm	vdc
1200	1217	4.9	1411	5.7	1576	6.4	1722	7.0	1855	7.5
1300	1283	5.2	1470	6.0	1631	6.6	1774	7.2	1904	7.7
1400	1351	5.5	1531	6.2	1688	6.9	1827	7.4	1955	7.9
1500	1420	5.8	1593	6.5	1746	7.1	1883	7.7	2008	8.2
1600	1491	6.1	1657	6.7	1805	7.3	1939	7.9	2062	8.4
1700	1563	6.4	1722	7.0	1866	7.6	1997	8.1	2118	8.6
1800	1635	6.6	1789	7.3	1928	7.8	2056	8.4	2174	8.8
1900	1709	6.9	1856	7.5	1991	8.1	2116	8.6	2232	9.1
2000	1784	7.3	1925	7.8	2056	8.4	2178	8.9	2291	9.3

CFM	AVAILABLE EXTERNAL STATIC PRESSURE (in. wg)									
	1.2		1.4		1.6		1.8		2.0	
	rpm	vdc	rpm	vdc	rpm	vdc	rpm	vdc	rpm	vdc
1200	1978	8.0	2094	8.5	2204	9.0	2308	9.4	2409	9.8
1300	2025	8.2	2138	8.7	2246	9.1	2349	9.5	2447	9.9
1400	2074	8.4	2185	8.9	2291	9.3	2391	9.7	—	—
1500	2124	8.6	2234	9.1	2338	9.5	2436	9.9	—	—
1600	2176	8.8	2284	9.3	2386	9.7	—	—	—	—
1700	2230	9.1	2336	9.5	2436	9.9	—	—	—	—
1800	2285	9.3	2389	9.7	—	—	—	—	—	—
1900	2341	9.5	2444	9.9	—	—	—	—	—	—
2000	2398	9.7	—	—	—	—	—	—	—	—

High Static 1217-2460 rpm 1.53, max bhp

NOTE: Fan tables include highest gas heat. Utilize static pressure deduction tables on page 39 for lower gas heat capacities.

48GCFJ05 Three Phase — 4 Ton Horizontal Supply (rpm - bhp)

CFM	AVAILABLE EXTERNAL STATIC PRESSURE (in. wg)									
	0.2		0.4		0.6		0.8		1.0	
	rpm	bhp	rpm	bhp	rpm	bhp	rpm	bhp	rpm	bhp
1200	1216	0.19	1411	0.30	1576	0.42	1722	0.55	1855	0.68
1300	1283	0.23	1470	0.34	1631	0.46	1774	0.60	1904	0.74
1400	1351	0.26	1531	0.38	1687	0.51	1827	0.65	1955	0.80
1500	1420	0.31	1593	0.43	1746	0.57	1882	0.71	2008	0.86
1600	1491	0.35	1657	0.48	1806	0.63	1939	0.78	2062	0.93
1700	1562	0.41	1722	0.54	1866	0.69	1998	0.85	2117	1.01
1800	1636	0.47	1788	0.61	1928	0.76	2056	0.92	2175	1.09
1900	1710	0.53	1856	0.68	1991	0.84	2117	1.01	2233	1.18
2000	1784	0.60	1924	0.76	2055	0.92	2178	1.10	2292	1.28

CFM	AVAILABLE EXTERNAL STATIC PRESSURE (in. wg)									
	1.2		1.4		1.6		1.8		2.0	
	rpm	bhp	rpm	bhp	rpm	bhp	rpm	bhp	rpm	bhp
1200	1978	0.83	2094	0.98	2204	1.15	2308	1.32	2409	1.50
1300	2025	0.89	2138	1.05	2246	1.21	2349	1.39	2447	1.57
1400	2073	0.95	2185	1.11	2291	1.28	2392	1.46	2488	1.64
1500	2124	1.02	2233	1.19	2338	1.36	2437	1.54	2532	1.73
1600	2176	1.10	2284	1.27	2386	1.45	2483	1.63	2577	1.82
1700	2230	1.18	2336	1.36	2436	1.54	2532	1.73	2624	1.92
1800	2285	1.27	2389	1.45	2488	1.64	2582	1.83	—	—
1900	2341	1.36	2443	1.55	2541	1.74	2634	1.94	—	—
2000	2399	1.46	2499	1.66	2595	1.85	—	—	—	—

- Standard Static 1216-1900 rpm, 0.72 max bhp
- Medium Static 1216-2170 rpm, 1.06 max bhp
- High Static 1216-2660 rpm, 1.96 max bhp

NOTE: Fan tables include highest gas heat. Utilize static pressure deduction tables on page 39 for lower gas heat capacities.

48GCFJ05 Three Phase — Standard Static — 4 Ton Horizontal Supply (rpm - vdc)

CFM	AVAILABLE EXTERNAL STATIC PRESSURE (in. wg)									
	0.2		0.4		0.6		0.8		1.0	
	rpm	vdc	rpm	vdc	rpm	vdc	rpm	vdc	rpm	vdc
1200	1216	6.4	1411	7.4	1576	8.3	1722	9.1	1855	9.8
1300	1283	6.8	1470	7.7	1631	8.6	1774	9.3	—	—
1400	1351	7.1	1531	8.1	1687	8.9	1827	9.6	—	—
1500	1420	7.5	1593	8.4	1746	9.2	1882	9.9	—	—
1600	1491	7.8	1657	8.7	1806	9.5	—	—	—	—
1700	1562	8.2	1722	9.1	1866	9.8	—	—	—	—
1800	1636	8.6	1788	9.4	—	—	—	—	—	—
1900	1710	9.0	1856	9.8	—	—	—	—	—	—
2000	1784	9.4	—	—	—	—	—	—	—	—

CFM	AVAILABLE EXTERNAL STATIC PRESSURE (in. wg)									
	1.2		1.4		1.6		1.8		2.0	
	rpm	vdc	rpm	vdc	rpm	vdc	rpm	vdc	rpm	vdc
1200	—	—	—	—	—	—	—	—	—	—
1300	—	—	—	—	—	—	—	—	—	—
1400	—	—	—	—	—	—	—	—	—	—
1500	—	—	—	—	—	—	—	—	—	—
1600	—	—	—	—	—	—	—	—	—	—
1700	—	—	—	—	—	—	—	—	—	—
1800	—	—	—	—	—	—	—	—	—	—
1900	—	—	—	—	—	—	—	—	—	—
2000	—	—	—	—	—	—	—	—	—	—

- Standard Static 1216-1900 rpm

NOTE: Fan tables include highest gas heat. Utilize static pressure deduction tables on page 39 for lower gas heat capacities.

48GCFJ05 Three Phase — Medium Static — 4 Ton Horizontal Supply (rpm - vdc)

CFM	AVAILABLE EXTERNAL STATIC PRESSURE (in. wg)									
	0.2		0.4		0.6		0.8		1.0	
	rpm	vdc	rpm	vdc	rpm	vdc	rpm	vdc	rpm	vdc
1200	1216	5.6	1411	6.5	1576	7.3	1722	7.9	1855	8.5
1300	1283	5.9	1470	6.8	1631	7.5	1774	8.2	1904	8.8
1400	1351	6.2	1531	7.1	1687	7.8	1827	8.4	1955	9.0
1500	1420	6.5	1593	7.3	1746	8.0	1882	8.7	2008	9.3
1600	1491	6.9	1657	7.6	1806	8.3	1939	8.9	2062	9.5
1700	1562	7.2	1722	7.9	1866	8.6	1998	9.2	2117	9.8
1800	1636	7.5	1788	8.2	1928	8.9	2056	9.5	—	—
1900	1710	7.9	1856	8.6	1991	9.2	2117	9.8	—	—
2000	1784	8.2	1924	8.9	2055	9.5	—	—	—	—

CFM	AVAILABLE EXTERNAL STATIC PRESSURE (in. wg)									
	1.2		1.4		1.6		1.8		2.0	
	rpm	vdc	rpm	vdc	rpm	vdc	rpm	vdc	rpm	vdc
1200	1978	9.1	2094	9.6	—	—	—	—	—	—
1300	2025	9.3	2138	9.9	—	—	—	—	—	—
1400	2073	9.6	—	—	—	—	—	—	—	—
1500	2124	9.8	—	—	—	—	—	—	—	—
1600	—	—	—	—	—	—	—	—	—	—
1700	—	—	—	—	—	—	—	—	—	—
1800	—	—	—	—	—	—	—	—	—	—
1900	—	—	—	—	—	—	—	—	—	—
2000	—	—	—	—	—	—	—	—	—	—

Medium Static 1216-2170 rpm

NOTE: Fan tables include highest gas heat. Utilize static pressure deduction tables on page 39 for lower gas heat capacities.

48GCFJ05 Three Phase — High Static — 4 Ton Horizontal Supply (rpm - vdc)

CFM	AVAILABLE EXTERNAL STATIC PRESSURE (in. wg)									
	0.2		0.4		0.6		0.8		1.0	
	rpm	vdc	rpm	vdc	rpm	vdc	rpm	vdc	rpm	vdc
1200	1216	4.6	1411	5.3	1576	5.9	1722	6.5	1855	7.0
1300	1283	4.8	1470	5.5	1631	6.1	1774	6.7	1904	7.2
1400	1351	5.1	1531	5.8	1687	6.3	1827	6.9	1955	7.3
1500	1420	5.3	1593	6.0	1746	6.6	1882	7.1	2008	7.5
1600	1491	5.6	1657	6.2	1806	6.8	1939	7.3	2062	7.8
1700	1562	5.9	1722	6.5	1866	7.0	1998	7.5	2117	8.0
1800	1636	6.2	1788	6.7	1928	7.2	2056	7.7	2175	8.2
1900	1710	6.4	1856	7.0	1991	7.5	2117	8.0	2233	8.4
2000	1784	6.7	1924	7.2	2055	7.7	2178	8.2	2292	8.6

CFM	AVAILABLE EXTERNAL STATIC PRESSURE (in. wg)									
	1.2		1.4		1.6		1.8		2.0	
	rpm	vdc	rpm	vdc	rpm	vdc	rpm	vdc	rpm	vdc
1200	1978	7.4	2094	7.9	2204	8.3	2308	8.7	2409	9.1
1300	2025	7.6	2138	8.0	2246	8.4	2349	8.8	2447	9.2
1400	2073	7.8	2185	8.2	2291	8.6	2392	9.0	2488	9.4
1500	2124	8.0	2233	8.4	2338	8.8	2437	9.2	2532	9.5
1600	2176	8.2	2284	8.6	2386	9.0	2483	9.3	2577	9.7
1700	2230	8.4	2336	8.8	2436	9.2	2532	9.5	2624	9.9
1800	2285	8.6	2389	9.0	2488	9.4	2582	9.7	—	—
1900	2341	8.8	2443	9.2	2541	9.6	2634	9.9	—	—
2000	2399	9.0	2499	9.4	2595	9.8	—	—	—	—

High Static 1216-2660 rpm

NOTE: Fan tables include highest gas heat. Utilize static pressure deduction tables on page 39 for lower gas heat capacities.

48GCFT06 Single Phase — 5 Ton Horizontal Supply (rpm - bhp)

CFM	AVAILABLE EXTERNAL STATIC PRESSURE (in. wg)									
	0.2		0.4		0.6		0.8		1.0	
	rpm	bhp	rpm	bhp	rpm	bhp	rpm	bhp	rpm	bhp
1500	1335	0.25	1508	0.36	1661	0.49	1797	0.62	1921	0.75
1625	1418	0.30	1580	0.42	1727	0.55	1861	0.68	1983	0.82
1750	1502	0.36	1654	0.48	1797	0.61	1927	0.76	2046	0.91
1875	1589	0.42	1731	0.55	1867	0.69	1994	0.84	2111	0.99
2000	1676	0.50	1810	0.63	1940	0.77	2063	0.93	2177	1.09
2125	1765	0.58	1891	0.71	2015	0.86	2133	1.02	2245	1.19
2250	1855	0.67	1973	0.81	2091	0.96	2206	1.13	2314	1.31
2375	1946	0.78	2057	0.92	2169	1.07	2279	1.25	2385	1.43
2500	2038	0.89	2142	1.03	2249	1.20	2355	1.37	—	—

CFM	AVAILABLE EXTERNAL STATIC PRESSURE (in. wg)									
	1.2		1.4		1.6		1.8		2.0	
	rpm	bhp	rpm	bhp	rpm	bhp	rpm	bhp	rpm	bhp
1500	2036	0.89	2143	1.04	2245	1.20	2342	1.36	—	—
1625	2096	0.97	2201	1.13	2301	1.29	—	—	—	—
1750	2157	1.06	2261	1.22	2359	1.39	—	—	—	—
1875	2220	1.16	2322	1.32	—	—	—	—	—	—
2000	2284	1.26	2385	1.43	—	—	—	—	—	—
2125	2350	1.37	—	—	—	—	—	—	—	—
2250	—	—	—	—	—	—	—	—	—	—
2375	—	—	—	—	—	—	—	—	—	—
2500	—	—	—	—	—	—	—	—	—	—

Standard Static 1335-2150 rpm, 1.06 max bhp

Medium Static 1335-2390 rpm, 1.44 max bhp

NOTE: Fan tables include highest gas heat. Utilize static pressure deduction tables on page 39 for lower gas heat capacities.

48GCFT06 Single Phase — Standard Static — 5 Ton Horizontal Supply (rpm - vdc)

CFM	AVAILABLE EXTERNAL STATIC PRESSURE (in. wg)									
	0.2		0.4		0.6		0.8		1.0	
	rpm	vdc	rpm	vdc	rpm	vdc	rpm	vdc	rpm	vdc
1500	1335	6.2	1507	7.0	1660	7.7	1796	8.4	1921	8.9
1625	1417	6.6	1580	7.3	1727	8.0	1860	8.7	1982	9.2
1750	1502	7.0	1654	7.7	1796	8.4	1926	9.0	2046	9.5
1875	1589	7.4	1731	8.1	1867	8.7	1993	9.3	2110	9.8
2000	1677	7.8	1810	8.4	1940	9.0	2062	9.6	—	—
2125	1765	8.2	1890	8.8	2015	9.4	2133	9.9	—	—
2250	1855	8.6	1972	9.2	2091	9.7	—	—	—	—
2375	1946	9.1	2057	9.6	—	—	—	—	—	—
2500	2038	9.5	2142	10.0	—	—	—	—	—	—

CFM	AVAILABLE EXTERNAL STATIC PRESSURE (in. wg)									
	1.2		1.4		1.6		1.8		2.0	
	rpm	vdc	rpm	vdc	rpm	vdc	rpm	vdc	rpm	vdc
1500	2036	9.5	2143	10.0	—	—	—	—	—	—
1625	2095	9.7	—	—	—	—	—	—	—	—
1750	—	—	—	—	—	—	—	—	—	—
1875	—	—	—	—	—	—	—	—	—	—
2000	—	—	—	—	—	—	—	—	—	—
2125	—	—	—	—	—	—	—	—	—	—
2250	—	—	—	—	—	—	—	—	—	—
2375	—	—	—	—	—	—	—	—	—	—
2500	—	—	—	—	—	—	—	—	—	—

Standard Static 1335-2150 rpm

NOTE: Fan tables include highest gas heat. Utilize static pressure deduction tables on page 39 for lower gas heat capacities.

48GCFT06 Single Phase — Medium Static — 5 Ton Horizontal Supply (rpm - vdc)

CFM	AVAILABLE EXTERNAL STATIC PRESSURE (in. wg)									
	0.2		0.4		0.6		0.8		1.0	
	rpm	vdc	rpm	vdc	rpm	vdc	rpm	vdc	rpm	vdc
1500	1335	5.6	1507	6.3	1660	6.9	1796	7.5	1921	8.0
1625	1417	5.9	1580	6.6	1727	7.2	1860	7.8	1982	8.3
1750	1502	6.3	1654	6.9	1796	7.5	1926	8.1	2046	8.6
1875	1589	6.6	1731	7.2	1867	7.8	1993	8.3	2110	8.8
2000	1677	7.0	1810	7.6	1940	8.1	2062	8.6	2177	9.1
2125	1765	7.4	1890	7.9	2015	8.4	2133	8.9	2244	9.4
2250	1855	7.8	1972	8.3	2091	8.7	2206	9.2	2314	9.7
2375	1946	8.1	2057	8.6	2169	9.1	2279	9.5	2385	10.0
2500	2038	8.5	2142	9.0	2249	9.4	2355	9.9	—	—

CFM	AVAILABLE EXTERNAL STATIC PRESSURE (in. wg)									
	1.2		1.4		1.6		1.8		2.0	
	rpm	vdc	rpm	vdc	rpm	vdc	rpm	vdc	rpm	vdc
1500	2036	8.5	2143	9.0	2245	9.4	2342	9.8	—	—
1625	2095	8.8	2201	9.2	2301	9.6	—	—	—	—
1750	2157	9.0	2261	9.5	2359	9.9	—	—	—	—
1875	2219	9.3	2322	9.7	—	—	—	—	—	—
2000	2284	9.6	2384	10.0	—	—	—	—	—	—
2125	2349	9.8	—	—	—	—	—	—	—	—
2250	—	—	—	—	—	—	—	—	—	—
2375	—	—	—	—	—	—	—	—	—	—
2500	—	—	—	—	—	—	—	—	—	—

Medium Static 1335-2390 rpm

NOTE: Fan tables include highest gas heat. Utilize static pressure deduction tables on page 39 for lower gas heat capacities.

48GCFJ06 Three Phase — 5 Ton Horizontal Supply (rpm - bhp)

CFM	AVAILABLE EXTERNAL STATIC PRESSURE (in. wg)									
	0.2		0.4		0.6		0.8		1.0	
	rpm	bhp	rpm	bhp	rpm	bhp	rpm	bhp	rpm	bhp
1500	1335	0.25	1507	0.36	1660	0.49	1796	0.61	1921	0.75
1625	1418	0.30	1579	0.42	1727	0.55	1860	0.68	1982	0.82
1750	1502	0.36	1654	0.48	1797	0.61	1927	0.76	2046	0.91
1875	1589	0.42	1731	0.55	1867	0.69	1994	0.84	2111	0.99
2000	1676	0.50	1810	0.63	1940	0.77	2063	0.93	2177	1.09
2125	1765	0.58	1890	0.71	2015	0.86	2133	1.02	2245	1.19
2250	1855	0.67	1973	0.81	2091	0.96	2206	1.13	2314	1.31
2375	1946	0.78	2057	0.92	2169	1.07	2279	1.25	2385	1.43
2500	2038	0.89	2142	1.03	2249	1.20	2355	1.37	2457	1.56

CFM	AVAILABLE EXTERNAL STATIC PRESSURE (in. wg)									
	1.2		1.4		1.6		1.8		2.0	
	rpm	bhp	rpm	bhp	rpm	bhp	rpm	bhp	rpm	bhp
1500	2036	0.89	2144	1.05	2245	1.20	2342	1.36	2435	1.53
1625	2095	0.97	2201	1.13	2301	1.29	2396	1.46	2487	1.63
1750	2157	1.06	2261	1.22	2359	1.39	2453	1.56	2543	1.74
1875	2219	1.15	2322	1.32	2419	1.49	2511	1.67	2599	1.85
2000	2284	1.26	2384	1.43	2480	1.61	2571	1.79	2658	1.98
2125	2350	1.37	2449	1.55	2542	1.73	2632	1.92	2718	2.12
2250	2417	1.49	2514	1.67	2607	1.87	2695	2.06	2779	2.26
2375	2485	1.62	2581	1.81	2672	2.01	2759	2.21	—	—
2500	2555	1.76	2648	1.95	2738	2.16	2824	2.37	—	—

- Standard Static 1335-2150 rpm, 1.06 max bhp
- Medium Static 1335-2390 rpm, 1.44 max bhp
- High Static 1335-2836 rpm, 2.43 max bhp

NOTE: Fan tables include highest gas heat. Utilize static pressure deduction tables on page 39 for lower gas heat capacities.

48GCFJ06 Three Phase — Standard Static — 5 Ton Horizontal Supply (rpm - vdc)

CFM	AVAILABLE EXTERNAL STATIC PRESSURE (in. wg)									
	0.2		0.4		0.6		0.8		1.0	
	rpm	vdc	rpm	vdc	rpm	vdc	rpm	vdc	rpm	vdc
1500	1335	6.2	1507	7.0	1660	7.7	1796	8.4	1921	8.9
1625	1418	6.6	1579	7.3	1727	8.0	1860	8.7	1982	9.2
1750	1502	7.0	1654	7.7	1797	8.4	1927	9.0	2046	9.5
1875	1589	7.4	1731	8.1	1867	8.7	1994	9.3	2111	9.8
2000	1676	7.8	1810	8.4	1940	9.0	2063	9.6	—	—
2125	1765	8.2	1890	8.8	2015	9.4	2133	9.9	—	—
2250	1855	8.6	1973	9.2	2091	9.7	—	—	—	—
2375	1946	9.1	2057	9.6	—	—	—	—	—	—
2500	2038	9.5	2142	10.0	—	—	—	—	—	—

CFM	AVAILABLE EXTERNAL STATIC PRESSURE (in. wg)									
	1.2		1.4		1.6		1.8		2.0	
	rpm	vdc	rpm	vdc	rpm	vdc	rpm	vdc	rpm	vdc
1500	2036	9.5	2144	10.0	—	—	—	—	—	—
1625	2095	9.7	—	—	—	—	—	—	—	—
1750	—	—	—	—	—	—	—	—	—	—
1875	—	—	—	—	—	—	—	—	—	—
2000	—	—	—	—	—	—	—	—	—	—
2125	—	—	—	—	—	—	—	—	—	—
2250	—	—	—	—	—	—	—	—	—	—
2375	—	—	—	—	—	—	—	—	—	—
2500	—	—	—	—	—	—	—	—	—	—

- Standard Static 1335-2150 rpm

NOTE: Fan tables include highest gas heat. Utilize static pressure deduction tables on page 39 for lower gas heat capacities.

48GCFJ06 Three Phase — Medium Static — 5 Ton Horizontal Supply (rpm - vdc)

CFM	AVAILABLE EXTERNAL STATIC PRESSURE (in. wg)									
	0.2		0.4		0.6		0.8		1.0	
	rpm	vdc	rpm	vdc	rpm	vdc	rpm	vdc	rpm	vdc
1500	1335	5.6	1507	6.3	1660	6.9	1796	7.5	1921	8.0
1625	1418	5.9	1579	6.6	1727	7.2	1860	7.8	1982	8.3
1750	1502	6.3	1654	6.9	1797	7.5	1927	8.1	2046	8.6
1875	1589	6.6	1731	7.2	1867	7.8	1994	8.3	2111	8.8
2000	1676	7.0	1810	7.6	1940	8.1	2063	8.6	2177	9.1
2125	1765	7.4	1890	7.9	2015	8.4	2133	8.9	2245	9.4
2250	1855	7.8	1973	8.3	2091	8.7	2206	9.2	2314	9.7
2375	1946	8.1	2057	8.6	2169	9.1	2279	9.5	2385	10.0
2500	2038	8.5	2142	9.0	2249	9.4	2355	9.9	—	—

CFM	AVAILABLE EXTERNAL STATIC PRESSURE (in. wg)									
	1.2		1.4		1.6		1.8		2.0	
	rpm	vdc	rpm	vdc	rpm	vdc	rpm	vdc	rpm	vdc
1500	2036	8.5	2144	9.0	2245	9.4	2342	9.8	—	—
1625	2095	8.8	2201	9.2	2301	9.6	—	—	—	—
1750	2157	9.0	2261	9.5	2359	9.9	—	—	—	—
1875	2219	9.3	2322	9.7	—	—	—	—	—	—
2000	2284	9.6	2384	10.0	—	—	—	—	—	—
2125	2350	9.8	—	—	—	—	—	—	—	—
2250	—	—	—	—	—	—	—	—	—	—
2375	—	—	—	—	—	—	—	—	—	—
2500	—	—	—	—	—	—	—	—	—	—

Medium Static 1335-2390 rpm

NOTE: Fan tables include highest gas heat. Utilize static pressure deduction tables on page 39 for lower gas heat capacities.

48GCFJ06 Three Phase — High Static — 5 Ton Horizontal Supply (rpm - vdc)

CFM	AVAILABLE EXTERNAL STATIC PRESSURE (in. wg)									
	0.2		0.4		0.6		0.8		1.0	
	rpm	vdc	rpm	vdc	rpm	vdc	rpm	vdc	rpm	vdc
1500	1335	4.7	1507	5.3	1660	5.9	1796	6.3	1921	6.8
1625	1418	5.0	1579	5.6	1727	6.1	1860	6.6	1982	7.0
1750	1502	5.3	1654	5.8	1797	6.3	1927	6.8	2046	7.2
1875	1589	5.6	1731	6.1	1867	6.6	1994	7.0	2111	7.4
2000	1676	5.9	1810	6.4	1940	6.8	2063	7.3	2177	7.7
2125	1765	6.2	1890	6.7	2015	7.1	2133	7.5	2245	7.9
2250	1855	6.5	1973	7.0	2091	7.4	2206	7.8	2314	8.2
2375	1946	6.9	2057	7.3	2169	7.6	2279	8.0	2385	8.4
2500	2038	7.2	2142	7.6	2249	7.9	2355	8.3	2457	8.7

CFM	AVAILABLE EXTERNAL STATIC PRESSURE (in. wg)									
	1.2		1.4		1.6		1.8		2.0	
	rpm	vdc	rpm	vdc	rpm	vdc	rpm	vdc	rpm	vdc
1500	2036	7.2	2144	7.6	2245	7.9	2342	8.3	2435	8.6
1625	2095	7.4	2201	7.8	2301	8.1	2396	8.4	2487	8.8
1750	2157	7.6	2261	8.0	2359	8.3	2453	8.6	2543	9.0
1875	2219	7.8	2322	8.2	2419	8.5	2511	8.9	2599	9.2
2000	2284	8.1	2384	8.4	2480	8.7	2571	9.1	2658	9.4
2125	2350	8.3	2449	8.6	2542	9.0	2632	9.3	2718	9.6
2250	2417	8.5	2514	8.9	2607	9.2	2695	9.5	2779	9.8
2375	2485	8.8	2581	9.1	2672	9.4	2759	9.7	—	—
2500	2555	9.0	2648	9.3	2738	9.7	2824	10.0	—	—

High Static 1335-2836 rpm

NOTE: Fan tables include highest gas heat. Utilize static pressure deduction tables on page 39 for lower gas heat capacities.

50GC-T04 Single Phase — 3 Ton Vertical Supply (rpm - bhp)

CFM	AVAILABLE EXTERNAL STATIC PRESSURE (in. wg)									
	0.2		0.4		0.6		0.8		1.0	
	rpm	bhp	rpm	bhp	rpm	bhp	rpm	bhp	rpm	bhp
900	1060	0.08	1325	0.16	1541	0.25	1718	0.35	1870	0.46
975	1103	0.09	1356	0.17	1572	0.27	1752	0.37	1906	0.48
1050	1149	0.11	1388	0.19	1602	0.29	1784	0.40	1941	0.51
1125	1198	0.12	1423	0.20	1632	0.30	1815	0.42	1973	0.53
1200	1249	0.14	1460	0.22	1663	0.32	1845	0.44	2005	0.56
1275	1302	0.15	1500	0.24	1694	0.34	1875	0.46	2036	0.59
1350	1356	0.17	1542	0.26	1728	0.36	1905	0.48	2066	0.61
1425	1412	0.20	1587	0.28	1764	0.38	1936	0.51	2096	0.64
1500	1469	0.22	1634	0.30	1803	0.41	1968	0.53	2126	0.67

CFM	AVAILABLE EXTERNAL STATIC PRESSURE (in. wg)									
	1.2		1.4		1.6		1.8		2.0	
	rpm	bhp	rpm	bhp	rpm	bhp	rpm	bhp	rpm	bhp
900	2006	0.56	2130	0.67	2244	0.79	2352	0.91	2453	1.03
975	2044	0.59	2168	0.71	2283	0.83	2391	0.95	—	—
1050	2080	0.63	2206	0.75	2322	0.87	2430	1.00	—	—
1125	2115	0.66	2242	0.78	2359	0.91	2468	1.05	—	—
1200	2148	0.69	2277	0.82	2396	0.96	—	—	—	—
1275	2180	0.72	2311	0.86	2431	1.00	—	—	—	—
1350	2211	0.75	2343	0.90	2465	1.04	—	—	—	—
1425	2241	0.78	2375	0.93	—	—	—	—	—	—
1500	2271	0.82	2405	0.97	—	—	—	—	—	—

- Standard Static 1060-1890 rpm, 0.44 max bhp
- Medium Static 1060-2190 rpm, 0.71 max bhp
- High Static 1060-2490 rpm, 1.07 max bhp

50GC-T04 Single Phase — Standard Static — 3 Ton Vertical Supply (rpm - vdc)

CFM	AVAILABLE EXTERNAL STATIC PRESSURE (in. wg)									
	0.2		0.4		0.6		0.8		1.0	
	rpm	vdc	rpm	vdc	rpm	vdc	rpm	vdc	rpm	vdc
900	1060	5.6	1325	7.0	1541	8.2	1718	9.1	1870	9.9
975	1103	5.8	1356	7.2	1572	8.3	1752	9.3	—	—
1050	1149	6.1	1388	7.3	1602	8.5	1784	9.4	—	—
1125	1198	6.3	1423	7.5	1632	8.6	1815	9.6	—	—
1200	1249	6.6	1460	7.7	1663	8.8	1845	9.8	—	—
1275	1302	6.9	1500	7.9	1694	9.0	—	—	—	—
1350	1356	7.2	1542	8.2	1728	9.1	—	—	—	—
1425	1412	7.5	1587	8.4	1764	9.3	—	—	—	—
1500	1469	7.8	1634	8.6	1803	9.5	—	—	—	—

CFM	AVAILABLE EXTERNAL STATIC PRESSURE (in. wg)									
	1.2		1.4		1.6		1.8		2.0	
	rpm	vdc	rpm	vdc	rpm	vdc	rpm	vdc	rpm	vdc
900	—	—	—	—	—	—	—	—	—	—
975	—	—	—	—	—	—	—	—	—	—
1050	—	—	—	—	—	—	—	—	—	—
1125	—	—	—	—	—	—	—	—	—	—
1200	—	—	—	—	—	—	—	—	—	—
1275	—	—	—	—	—	—	—	—	—	—
1350	—	—	—	—	—	—	—	—	—	—
1425	—	—	—	—	—	—	—	—	—	—
1500	—	—	—	—	—	—	—	—	—	—

- Standard Static 1060-1890 rpm

50GC-T04 Single Phase — Medium Static — 3 Ton Vertical Supply (rpm - vdc)

CFM	AVAILABLE EXTERNAL STATIC PRESSURE (in. wg)									
	0.2		0.4		0.6		0.8		1.0	
	rpm	vdc	rpm	vdc	rpm	vdc	rpm	vdc	rpm	vdc
900	1060	4.8	1325	6.1	1541	7.0	1718	7.8	1870	8.5
975	1103	5.0	1356	6.2	1572	7.2	1752	8.0	1906	8.7
1050	1149	5.2	1388	6.3	1602	7.3	1784	8.1	1941	8.9
1125	1198	5.5	1423	6.5	1632	7.5	1815	8.3	1973	9.0
1200	1249	5.7	1460	6.7	1663	7.6	1845	8.4	2005	9.2
1275	1302	5.9	1500	6.8	1694	7.7	1875	8.6	2036	9.3
1350	1356	6.2	1542	7.0	1728	7.9	1905	8.7	2066	9.4
1425	1412	6.4	1587	7.2	1764	8.1	1936	8.8	2096	9.6
1500	1469	6.7	1634	7.5	1803	8.2	1968	9.0	2126	9.7

CFM	AVAILABLE EXTERNAL STATIC PRESSURE (in. wg)									
	1.2		1.4		1.6		1.8		2.0	
	rpm	vdc	rpm	vdc	rpm	vdc	rpm	vdc	rpm	vdc
900	2006	9.2	2130	9.7	—	—	—	—	—	—
975	2044	9.3	2168	9.9	—	—	—	—	—	—
1050	2080	9.5	—	—	—	—	—	—	—	—
1125	2115	9.7	—	—	—	—	—	—	—	—
1200	2148	9.8	—	—	—	—	—	—	—	—
1275	2180	10.0	—	—	—	—	—	—	—	—
1350	—	—	—	—	—	—	—	—	—	—
1425	—	—	—	—	—	—	—	—	—	—
1500	—	—	—	—	—	—	—	—	—	—

Medium Static 1060-2190 rpm

50GC-T04 Single Phase — High Static — 3 Ton Vertical Supply (rpm - vdc)

CFM	AVAILABLE EXTERNAL STATIC PRESSURE (in. wg)									
	0.2		0.4		0.6		0.8		1.0	
	rpm	vdc	rpm	vdc	rpm	vdc	rpm	vdc	rpm	vdc
900	1060	4.3	1325	5.3	1541	6.2	1718	6.9	1870	7.5
975	1103	4.4	1356	5.4	1572	6.3	1752	7.0	1906	7.7
1050	1149	4.6	1388	5.6	1602	6.4	1784	7.2	1941	7.8
1125	1198	4.8	1423	5.7	1632	6.6	1815	7.3	1973	7.9
1200	1249	5.0	1460	5.9	1663	6.7	1845	7.4	2005	8.1
1275	1302	5.2	1500	6.0	1694	6.8	1875	7.5	2036	8.2
1350	1356	5.4	1542	6.2	1728	6.9	1905	7.7	2066	8.3
1425	1412	5.7	1587	6.4	1764	7.1	1936	7.8	2096	8.4
1500	1469	5.9	1634	6.6	1803	7.2	1968	7.9	2126	8.5

CFM	AVAILABLE EXTERNAL STATIC PRESSURE (in. wg)									
	1.2		1.4		1.6		1.8		2.0	
	rpm	vdc	rpm	vdc	rpm	vdc	rpm	vdc	rpm	vdc
900	2006	8.1	2130	8.6	2244	9.0	2352	9.4	2453	9.9
975	2044	8.2	2168	8.7	2283	9.2	2391	9.6	—	—
1050	2080	8.4	2206	8.9	2322	9.3	2430	9.8	—	—
1125	2115	8.5	2242	9.0	2359	9.5	2468	9.9	—	—
1200	2148	8.6	2277	9.1	2396	9.6	—	—	—	—
1275	2180	8.8	2311	9.3	2431	9.8	—	—	—	—
1350	2211	8.9	2343	9.4	2465	9.9	—	—	—	—
1425	2241	9.0	2375	9.5	—	—	—	—	—	—
1500	2271	9.1	2405	9.7	—	—	—	—	—	—

High Static 1060-2490 rpm

50GC-J04 Three Phase — 3 Ton Vertical Supply (rpm - bhp)

CFM	AVAILABLE EXTERNAL STATIC PRESSURE (in. wg)									
	0.2		0.4		0.6		0.8		1.0	
	rpm	bhp	rpm	bhp	rpm	bhp	rpm	bhp	rpm	bhp
900	1060	0.08	1325	0.16	1541	0.25	1718	0.35	1870	0.46
975	1103	0.09	1356	0.17	1572	0.27	1752	0.37	1906	0.48
1050	1149	0.11	1388	0.19	1602	0.29	1784	0.40	1941	0.51
1125	1198	0.12	1423	0.20	1632	0.30	1815	0.42	1973	0.53
1200	1249	0.14	1460	0.22	1663	0.32	1845	0.44	2005	0.56
1275	1302	0.15	1500	0.24	1694	0.34	1875	0.46	2036	0.59
1350	1356	0.17	1542	0.26	1728	0.36	1905	0.48	2066	0.61
1425	1412	0.20	1587	0.28	1764	0.38	1936	0.51	2096	0.64
1500	1469	0.22	1634	0.30	1803	0.41	1968	0.53	2126	0.67

CFM	AVAILABLE EXTERNAL STATIC PRESSURE (in. wg)									
	1.2		1.4		1.6		1.8		2.0	
	rpm	bhp	rpm	bhp	rpm	bhp	rpm	bhp	rpm	bhp
900	2006	0.56	2130	0.67	2244	0.79	2352	0.91	2453	1.03
975	2044	0.59	2168	0.71	2283	0.83	2391	0.95	—	—
1050	2080	0.63	2206	0.75	2322	0.87	2430	1.00	—	—
1125	2115	0.66	2242	0.78	2359	0.91	2468	1.05	—	—
1200	2148	0.69	2277	0.82	2396	0.96	—	—	—	—
1275	2180	0.72	2311	0.86	2431	1.00	—	—	—	—
1350	2211	0.75	2343	0.90	2465	1.04	—	—	—	—
1425	2241	0.78	2375	0.93	—	—	—	—	—	—
1500	2271	0.82	2405	0.97	—	—	—	—	—	—

Standard Static 1060-1890 rpm, 0.44 max bhp

Medium Static 1060-2190 rpm, 0.71 max bhp

High Static 1060-2490 rpm, 1.07 max bhp

50GC-J04 Three Phase — Standard Static — 3 Ton Vertical Supply (rpm - vdc)

CFM	AVAILABLE EXTERNAL STATIC PRESSURE (in. wg)									
	0.2		0.4		0.6		0.8		1.0	
	rpm	vdc	rpm	vdc	rpm	vdc	rpm	vdc	rpm	vdc
900	1060	5.6	1325	7.0	1541	8.2	1718	9.1	1870	9.9
975	1103	5.8	1356	7.2	1572	8.3	1752	9.3	—	—
1050	1149	6.1	1388	7.3	1602	8.5	1784	9.4	—	—
1125	1198	6.3	1423	7.5	1632	8.6	1815	9.6	—	—
1200	1249	6.6	1460	7.7	1663	8.8	1845	9.8	—	—
1275	1302	6.9	1500	7.9	1694	9.0	—	—	—	—
1350	1356	7.2	1542	8.2	1728	9.1	—	—	—	—
1425	1412	7.5	1587	8.4	1764	9.3	—	—	—	—
1500	1469	7.8	1634	8.6	1803	9.5	—	—	—	—

CFM	AVAILABLE EXTERNAL STATIC PRESSURE (in. wg)									
	1.2		1.4		1.6		1.8		2.0	
	rpm	vdc	rpm	vdc	rpm	vdc	rpm	vdc	rpm	vdc
900	—	—	—	—	—	—	—	—	—	—
975	—	—	—	—	—	—	—	—	—	—
1050	—	—	—	—	—	—	—	—	—	—
1125	—	—	—	—	—	—	—	—	—	—
1200	—	—	—	—	—	—	—	—	—	—
1275	—	—	—	—	—	—	—	—	—	—
1350	—	—	—	—	—	—	—	—	—	—
1425	—	—	—	—	—	—	—	—	—	—
1500	—	—	—	—	—	—	—	—	—	—

Standard Static 1060-1890 rpm

50GC-J04 Three Phase — Medium Static — 3 Ton Vertical Supply (rpm - vdc)

CFM	AVAILABLE EXTERNAL STATIC PRESSURE (in. wg)									
	0.2		0.4		0.6		0.8		1.0	
	rpm	vdc	rpm	vdc	rpm	vdc	rpm	vdc	rpm	vdc
900	1060	4.8	1325	6.1	1541	7.0	1718	7.8	1870	8.5
975	1103	5.0	1356	6.2	1572	7.2	1752	8.0	1906	8.7
1050	1149	5.2	1388	6.3	1602	7.3	1784	8.1	1941	8.9
1125	1198	5.5	1423	6.5	1632	7.5	1815	8.3	1973	9.0
1200	1249	5.7	1460	6.7	1663	7.6	1845	8.4	2005	9.2
1275	1302	5.9	1500	6.8	1694	7.7	1875	8.6	2036	9.3
1350	1356	6.2	1542	7.0	1728	7.9	1905	8.7	2066	9.4
1425	1412	6.4	1587	7.2	1764	8.1	1936	8.8	2096	9.6
1500	1469	6.7	1634	7.5	1803	8.2	1968	9.0	2126	9.7

CFM	AVAILABLE EXTERNAL STATIC PRESSURE (in. wg)									
	1.2		1.4		1.6		1.8		2.0	
	rpm	vdc	rpm	vdc	rpm	vdc	rpm	vdc	rpm	vdc
900	2006	9.2	2130	9.7	—	—	—	—	—	—
975	2044	9.3	2168	9.9	—	—	—	—	—	—
1050	2080	9.5	—	—	—	—	—	—	—	—
1125	2115	9.7	—	—	—	—	—	—	—	—
1200	2148	9.8	—	—	—	—	—	—	—	—
1275	2180	10.0	—	—	—	—	—	—	—	—
1350	—	—	—	—	—	—	—	—	—	—
1425	—	—	—	—	—	—	—	—	—	—
1500	—	—	—	—	—	—	—	—	—	—

Medium Static 1060-2190 rpm

50GC-J04 Three Phase — High Static — 3 Ton Vertical Supply (rpm - vdc)

CFM	AVAILABLE EXTERNAL STATIC PRESSURE (in. wg)									
	0.2		0.4		0.6		0.8		1.0	
	rpm	vdc	rpm	vdc	rpm	vdc	rpm	vdc	rpm	vdc
900	1060	4.3	1325	5.3	1541	6.2	1718	6.9	1870	7.5
975	1103	4.4	1356	5.4	1572	6.3	1752	7.0	1906	7.7
1050	1149	4.6	1388	5.6	1602	6.4	1784	7.2	1941	7.8
1125	1198	4.8	1423	5.7	1632	6.6	1815	7.3	1973	7.9
1200	1249	5.0	1460	5.9	1663	6.7	1845	7.4	2005	8.1
1275	1302	5.2	1500	6.0	1694	6.8	1875	7.5	2036	8.2
1350	1356	5.4	1542	6.2	1728	6.9	1905	7.7	2066	8.3
1425	1412	5.7	1587	6.4	1764	7.1	1936	7.8	2096	8.4
1500	1469	5.9	1634	6.6	1803	7.2	1968	7.9	2126	8.5

CFM	AVAILABLE EXTERNAL STATIC PRESSURE (in. wg)									
	1.2		1.4		1.6		1.8		2.0	
	rpm	vdc	rpm	vdc	rpm	vdc	rpm	vdc	rpm	vdc
900	2006	8.1	2130	8.6	2244	9.0	2352	9.4	2453	9.9
975	2044	8.2	2168	8.7	2283	9.2	2391	9.6	—	—
1050	2080	8.4	2206	8.9	2322	9.3	2430	9.8	—	—
1125	2115	8.5	2242	9.0	2359	9.5	2468	9.9	—	—
1200	2148	8.6	2277	9.1	2396	9.6	—	—	—	—
1275	2180	8.8	2311	9.3	2431	9.8	—	—	—	—
1350	2211	8.9	2343	9.4	2465	9.9	—	—	—	—
1425	2241	9.0	2375	9.5	—	—	—	—	—	—
1500	2271	9.1	2405	9.7	—	—	—	—	—	—

High Static 1060-2490 rpm

50GC-T05 Single Phase — 4 Ton Vertical Supply (rpm - bhp)

CFM	AVAILABLE EXTERNAL STATIC PRESSURE (in. wg)									
	0.2		0.4		0.6		0.8		1.0	
	rpm	bhp	rpm	bhp	rpm	bhp	rpm	bhp	rpm	bhp
1200	1121	0.15	1327	0.25	1507	0.37	1667	0.50	1814	0.65
1300	1179	0.18	1375	0.28	1549	0.40	1705	0.54	1849	0.69
1400	1239	0.21	1425	0.31	1593	0.44	1746	0.58	1886	0.73
1500	1301	0.24	1477	0.35	1639	0.47	1788	0.62	1925	0.77
1600	1365	0.27	1531	0.39	1688	0.52	1832	0.66	1966	0.82
1700	1430	0.31	1587	0.43	1738	0.56	1878	0.71	2009	0.87
1800	1496	0.36	1644	0.48	1789	0.61	1926	0.76	2053	0.93
1900	1565	0.41	1703	0.53	1842	0.67	1975	0.82	2099	0.99
2000	1633	0.46	1764	0.59	1897	0.73	2025	0.89	2147	1.06

CFM	AVAILABLE EXTERNAL STATIC PRESSURE (in. wg)									
	1.2		1.4		1.6		1.8		2.0	
	rpm	bhp	rpm	bhp	rpm	bhp	rpm	bhp	rpm	bhp
1200	1950	0.81	2077	0.97	2195	1.15	2306	1.33	2411	1.52
1300	1983	0.85	2108	1.02	2226	1.20	2337	1.38	—	—
1400	2017	0.89	2140	1.06	2257	1.24	2367	1.43	—	—
1500	2053	0.93	2174	1.11	2289	1.29	2398	1.49	—	—
1600	2092	0.98	2210	1.16	2323	1.35	—	—	—	—
1700	2132	1.04	2248	1.22	2359	1.41	—	—	—	—
1800	2174	1.10	2288	1.28	2397	1.47	—	—	—	—
1900	2217	1.16	2329	1.35	—	—	—	—	—	—
2000	2262	1.23	2372	1.42	—	—	—	—	—	—

Standard Static 1121-1900 rpm, 0.72 max bhp

Medium Static 1121-2170 rpm, 1.06 max bhp

High Static 1121-2460 rpm, 1.53 max bhp

50GC-T05 Single Phase — Standard Static — 4 Ton Vertical Supply (rpm - vdc)

CFM	AVAILABLE EXTERNAL STATIC PRESSURE (in. wg)									
	0.2		0.4		0.6		0.8		1.0	
	rpm	vdc	rpm	vdc	rpm	vdc	rpm	vdc	rpm	vdc
1200	1121	5.9	1327	7.0	1507	7.9	1667	8.8	1814	9.5
1300	1179	6.2	1375	7.2	1549	8.2	1705	9.0	1849	9.7
1400	1239	6.5	1425	7.5	1593	8.4	1746	9.2	1886	9.9
1500	1301	6.8	1477	7.8	1639	8.6	1788	9.4	—	—
1600	1365	7.2	1531	8.1	1688	8.9	1832	9.6	—	—
1700	1430	7.5	1587	8.4	1738	9.1	1878	9.9	—	—
1800	1496	7.9	1644	8.7	1789	9.4	—	—	—	—
1900	1565	8.2	1703	9.0	1842	9.7	—	—	—	—
2000	1633	8.6	1764	9.3	1897	10.0	—	—	—	—

CFM	AVAILABLE EXTERNAL STATIC PRESSURE (in. wg)									
	1.2		1.4		1.6		1.8		2.0	
	rpm	vdc	rpm	vdc	rpm	vdc	rpm	vdc	rpm	vdc
1200	—	—	—	—	—	—	—	—	—	—
1300	—	—	—	—	—	—	—	—	—	—
1400	—	—	—	—	—	—	—	—	—	—
1500	—	—	—	—	—	—	—	—	—	—
1600	—	—	—	—	—	—	—	—	—	—
1700	—	—	—	—	—	—	—	—	—	—
1800	—	—	—	—	—	—	—	—	—	—
1900	—	—	—	—	—	—	—	—	—	—
2000	—	—	—	—	—	—	—	—	—	—

Standard Static 1121-1900 rpm

50GC-T05 Single Phase — Medium Static — 4 Ton Vertical Supply (rpm - vdc)

CFM	AVAILABLE EXTERNAL STATIC PRESSURE (in. wg)									
	0.2		0.4		0.6		0.8		1.0	
	rpm	vdc	rpm	vdc	rpm	vdc	rpm	vdc	rpm	vdc
1200	1121	5.2	1327	6.1	1507	6.9	1667	7.7	1814	8.4
1300	1179	5.4	1375	6.3	1549	7.1	1705	7.9	1849	8.5
1400	1239	5.7	1425	6.6	1593	7.3	1746	8.0	1886	8.7
1500	1301	6.0	1477	6.8	1639	7.6	1788	8.2	1925	8.9
1600	1365	6.3	1531	7.1	1688	7.8	1832	8.4	1966	9.1
1700	1430	6.6	1587	7.3	1738	8.0	1878	8.7	2009	9.3
1800	1496	6.9	1644	7.6	1789	8.2	1926	8.9	2053	9.5
1900	1565	7.2	1703	7.8	1842	8.5	1975	9.1	2099	9.7
2000	1633	7.5	1764	8.1	1897	8.7	2025	9.3	2147	9.9

CFM	AVAILABLE EXTERNAL STATIC PRESSURE (in. wg)									
	1.2		1.4		1.6		1.8		2.0	
	rpm	vdc	rpm	vdc	rpm	vdc	rpm	vdc	rpm	vdc
1200	1950	9.0	2077	9.6	—	—	—	—	—	—
1300	1983	9.1	2108	9.7	—	—	—	—	—	—
1400	2017	9.3	2140	9.9	—	—	—	—	—	—
1500	2053	9.5	—	—	—	—	—	—	—	—
1600	2092	9.6	—	—	—	—	—	—	—	—
1700	2132	9.8	—	—	—	—	—	—	—	—
1800	—	—	—	—	—	—	—	—	—	—
1900	—	—	—	—	—	—	—	—	—	—
2000	—	—	—	—	—	—	—	—	—	—

Medium Static 1121-2170 rpm

50GC-T05 Single Phase — High Static — 4 Ton Vertical Supply (rpm - vdc)

CFM	AVAILABLE EXTERNAL STATIC PRESSURE (in. wg)									
	0.2		0.4		0.6		0.8		1.0	
	rpm	vdc	rpm	vdc	rpm	vdc	rpm	vdc	rpm	vdc
1200	1121	4.6	1327	5.4	1507	6.1	1667	6.8	1814	7.4
1300	1179	4.8	1375	5.6	1549	6.3	1705	6.9	1849	7.5
1400	1239	5.0	1425	5.8	1593	6.5	1746	7.1	1886	7.7
1500	1301	5.3	1477	6.0	1639	6.7	1788	7.3	1925	7.8
1600	1365	5.5	1531	6.2	1688	6.9	1832	7.4	1966	8.0
1700	1430	5.8	1587	6.5	1738	7.1	1878	7.6	2009	8.2
1800	1496	6.1	1644	6.7	1789	7.3	1926	7.8	2053	8.3
1900	1565	6.4	1703	6.9	1842	7.5	1975	8.0	2099	8.5
2000	1633	6.6	1764	7.2	1897	7.7	2025	8.2	2147	8.7

CFM	AVAILABLE EXTERNAL STATIC PRESSURE (in. wg)									
	1.2		1.4		1.6		1.8		2.0	
	rpm	vdc	rpm	vdc	rpm	vdc	rpm	vdc	rpm	vdc
1200	1950	7.9	2077	8.4	2195	8.9	2306	9.4	2411	9.8
1300	1983	8.1	2108	8.6	2226	9.0	2337	9.5	—	—
1400	2017	8.2	2140	8.7	2257	9.2	2367	9.6	—	—
1500	2053	8.3	2174	8.8	2289	9.3	2398	9.7	—	—
1600	2092	8.5	2210	9.0	2323	9.4	—	—	—	—
1700	2132	8.7	2248	9.1	2359	9.6	—	—	—	—
1800	2174	8.8	2288	9.3	2397	9.7	—	—	—	—
1900	2217	9.0	2329	9.5	—	—	—	—	—	—
2000	2262	9.2	2372	9.6	—	—	—	—	—	—

High Static 1121-2460 rpm

50GC-J05 Three Phase — 4 Ton Vertical Supply (rpm - bhp)

CFM	AVAILABLE EXTERNAL STATIC PRESSURE (in. wg)									
	0.2		0.4		0.6		0.8		1.0	
	rpm	bhp	rpm	bhp	rpm	bhp	rpm	bhp	rpm	bhp
1200	1120	0.15	1327	0.25	1506	0.37	1667	0.50	1814	0.65
1300	1178	0.18	1375	0.28	1549	0.40	1705	0.54	1849	0.69
1400	1238	0.21	1424	0.31	1593	0.44	1745	0.57	1886	0.73
1500	1300	0.24	1476	0.35	1639	0.47	1788	0.62	1925	0.77
1600	1365	0.27	1530	0.39	1687	0.52	1832	0.66	1966	0.82
1700	1430	0.31	1586	0.43	1737	0.56	1878	0.71	2009	0.87
1800	1497	0.36	1644	0.48	1789	0.61	1925	0.76	2053	0.93
1900	1565	0.41	1703	0.53	1842	0.67	1974	0.82	2099	0.99
2000	1633	0.46	1764	0.59	1897	0.73	2025	0.89	2146	1.05

CFM	AVAILABLE EXTERNAL STATIC PRESSURE (in. wg)									
	1.2		1.4		1.6		1.8		2.0	
	rpm	bhp	rpm	bhp	rpm	bhp	rpm	bhp	rpm	bhp
1200	1950	0.81	2077	0.97	2195	1.15	2306	1.33	2411	1.52
1300	1983	0.85	2108	1.02	2225	1.19	2336	1.38	2442	1.58
1400	2017	0.89	2140	1.06	2257	1.24	2367	1.43	2472	1.63
1500	2053	0.93	2174	1.11	2289	1.29	2398	1.49	2502	1.69
1600	2091	0.98	2210	1.16	2323	1.35	2431	1.55	2534	1.75
1700	2132	1.04	2248	1.22	2359	1.41	2465	1.61	2567	1.82
1800	2174	1.10	2288	1.28	2397	1.47	2501	1.67	2601	1.88
1900	2217	1.16	2329	1.35	2436	1.54	2539	1.75	2637	1.96
2000	2262	1.23	2372	1.42	2477	1.62	2578	1.83	—	—

- Standard Static 1120-1900 rpm, 0.72 max bhp
- Medium Static 1120-2170 rpm, 1.06 max bhp
- High Static 1120-2660 rpm, 1.96 max bhp

50GC-J05 Three Phase — Standard Static — 4 Ton Vertical Supply (rpm - vdc)

CFM	AVAILABLE EXTERNAL STATIC PRESSURE (in. wg)									
	0.2		0.4		0.6		0.8		1.0	
	rpm	vdc	rpm	vdc	rpm	vdc	rpm	vdc	rpm	vdc
1200	1120	5.9	1327	7.0	1506	7.9	1667	8.8	1814	9.5
1300	1178	6.2	1375	7.2	1549	8.2	1705	9.0	1849	9.7
1400	1238	6.5	1424	7.5	1593	8.4	1745	9.2	1886	9.9
1500	1300	6.8	1476	7.8	1639	8.6	1788	9.4	—	—
1600	1365	7.2	1530	8.1	1687	8.9	1832	9.6	—	—
1700	1430	7.5	1586	8.3	1737	9.1	1878	9.9	—	—
1800	1497	7.9	1644	8.7	1789	9.4	—	—	—	—
1900	1565	8.2	1703	9.0	1842	9.7	—	—	—	—
2000	1633	8.6	1764	9.3	1897	10.0	—	—	—	—

CFM	AVAILABLE EXTERNAL STATIC PRESSURE (in. wg)									
	1.2		1.4		1.6		1.8		2.0	
	rpm	vdc	rpm	vdc	rpm	vdc	rpm	vdc	rpm	vdc
1200	—	—	—	—	—	—	—	—	—	—
1300	—	—	—	—	—	—	—	—	—	—
1400	—	—	—	—	—	—	—	—	—	—
1500	—	—	—	—	—	—	—	—	—	—
1600	—	—	—	—	—	—	—	—	—	—
1700	—	—	—	—	—	—	—	—	—	—
1800	—	—	—	—	—	—	—	—	—	—
1900	—	—	—	—	—	—	—	—	—	—
2000	—	—	—	—	—	—	—	—	—	—

- Standard Static 1120-1900 rpm

50GC-J05 Three Phase — Medium Static — 4 Ton Vertical Supply (rpm - vdc)

CFM	AVAILABLE EXTERNAL STATIC PRESSURE (in. wg)									
	0.2		0.4		0.6		0.8		1.0	
	rpm	vdc	rpm	vdc	rpm	vdc	rpm	vdc	rpm	vdc
1200	1120	5.2	1327	6.1	1506	6.9	1667	7.7	1814	8.4
1300	1178	5.4	1375	6.3	1549	7.1	1705	7.9	1849	8.5
1400	1238	5.7	1424	6.6	1593	7.3	1745	8.0	1886	8.7
1500	1300	6.0	1476	6.8	1639	7.6	1788	8.2	1925	8.9
1600	1365	6.3	1530	7.1	1687	7.8	1832	8.4	1966	9.1
1700	1430	6.6	1586	7.3	1737	8.0	1878	8.7	2009	9.3
1800	1497	6.9	1644	7.6	1789	8.2	1925	8.9	2053	9.5
1900	1565	7.2	1703	7.8	1842	8.5	1974	9.1	2099	9.7
2000	1633	7.5	1764	8.1	1897	8.7	2025	9.3	2146	9.9

CFM	AVAILABLE EXTERNAL STATIC PRESSURE (in. wg)									
	1.2		1.4		1.6		1.8		2.0	
	rpm	vdc	rpm	vdc	rpm	vdc	rpm	vdc	rpm	vdc
1200	1950	9.0	2077	9.6	—	—	—	—	—	—
1300	1983	9.1	2108	9.7	—	—	—	—	—	—
1400	2017	9.3	2140	9.9	—	—	—	—	—	—
1500	2053	9.5	—	—	—	—	—	—	—	—
1600	2091	9.6	—	—	—	—	—	—	—	—
1700	2132	9.8	—	—	—	—	—	—	—	—
1800	—	—	—	—	—	—	—	—	—	—
1900	—	—	—	—	—	—	—	—	—	—
2000	—	—	—	—	—	—	—	—	—	—

Medium Static 1120-2170 rpm

50GC-J05 Three Phase — High Static — 4 Ton Vertical Supply (rpm - vdc)

CFM	AVAILABLE EXTERNAL STATIC PRESSURE (in. wg)									
	0.2		0.4		0.6		0.8		1.0	
	rpm	vdc	rpm	vdc	rpm	vdc	rpm	vdc	rpm	vdc
1200	1120	4.2	1327	5.0	1506	5.7	1667	6.3	1814	6.8
1300	1178	4.4	1375	5.2	1549	5.8	1705	6.4	1849	7.0
1400	1238	4.7	1424	5.4	1593	6.0	1745	6.6	1886	7.1
1500	1300	4.9	1476	5.5	1639	6.2	1788	6.7	1925	7.2
1600	1365	5.1	1530	5.8	1687	6.3	1832	6.9	1966	7.4
1700	1430	5.4	1586	6.0	1737	6.5	1878	7.1	2009	7.6
1800	1497	5.6	1644	6.2	1789	6.7	1925	7.2	2053	7.7
1900	1565	5.9	1703	6.4	1842	6.9	1974	7.4	2099	7.9
2000	1633	6.1	1764	6.6	1897	7.1	2025	7.6	2146	8.1

CFM	AVAILABLE EXTERNAL STATIC PRESSURE (in. wg)									
	1.2		1.4		1.6		1.8		2.0	
	rpm	vdc	rpm	vdc	rpm	vdc	rpm	vdc	rpm	vdc
1200	1950	7.3	2077	7.8	2195	8.3	2306	8.7	2411	9.1
1300	1983	7.5	2108	7.9	2225	8.4	2336	8.8	2442	9.2
1400	2017	7.6	2140	8.0	2257	8.5	2367	8.9	2472	9.3
1500	2053	7.7	2174	8.2	2289	8.6	2398	9.0	2502	9.4
1600	2091	7.9	2210	8.3	2323	8.7	2431	9.1	2534	9.5
1700	2132	8.0	2248	8.5	2359	8.9	2465	9.3	2567	9.7
1800	2174	8.2	2288	8.6	2397	9.0	2501	9.4	2601	9.8
1900	2217	8.3	2329	8.8	2436	9.2	2539	9.5	2637	9.9
2000	2262	8.5	2372	8.9	2477	9.3	2578	9.7	—	—

High Static 1120-2660 rpm

50GC-T06 Single Phase — 5 Ton Vertical Supply (rpm - bhp)

CFM	AVAILABLE EXTERNAL STATIC PRESSURE (in. wg)									
	0.2		0.4		0.6		0.8		1.0	
	rpm	bhp	rpm	bhp	rpm	bhp	rpm	bhp	rpm	bhp
1500	1228	0.20	1394	0.29	1554	0.40	1701	0.53	1835	0.66
1625	1305	0.24	1457	0.33	1609	0.44	1750	0.57	1881	0.71
1750	1385	0.28	1523	0.37	1666	0.49	1802	0.62	1930	0.76
1875	1466	0.33	1592	0.43	1726	0.54	1857	0.67	1981	0.82
2000	1549	0.39	1664	0.48	1789	0.60	1914	0.74	2034	0.88
2125	1633	0.46	1739	0.55	1855	0.67	1974	0.81	2089	0.95
2250	1718	0.53	1816	0.63	1924	0.74	2036	0.88	2146	1.03
2375	1803	0.61	1895	0.71	1994	0.83	2100	0.97	2206	1.12
2500	1890	0.70	1975	0.80	2068	0.92	2167	1.06	2268	1.21

CFM	AVAILABLE EXTERNAL STATIC PRESSURE (in. wg)									
	1.2		1.4		1.6		1.8		2.0	
	rpm	bhp	rpm	bhp	rpm	bhp	rpm	bhp	rpm	bhp
1500	1961	0.80	2079	0.96	2191	1.12	2298	1.29	—	—
1625	2004	0.85	2120	1.01	2229	1.18	2335	1.35	—	—
1750	2050	0.91	2163	1.07	2270	1.24	2373	1.41	—	—
1875	2098	0.97	2208	1.13	2314	1.31	—	—	—	—
2000	2148	1.04	2256	1.21	2359	1.38	—	—	—	—
2125	2200	1.11	2305	1.28	—	—	—	—	—	—
2250	2254	1.20	2357	1.37	—	—	—	—	—	—
2375	2310	1.28	—	—	—	—	—	—	—	—
2500	2368	1.38	—	—	—	—	—	—	—	—

Standard Static 1228-2150 rpm, 1.06 max bhp

Medium Static 1228-2390 rpm, 1.44 max bhp

50GC-T06 Single Phase — Standard Static — 5 Ton Vertical Supply (rpm - vdc)

CFM	AVAILABLE EXTERNAL STATIC PRESSURE (in. wg)									
	0.2		0.4		0.6		0.8		1.0	
	rpm	vdc	rpm	vdc	rpm	vdc	rpm	vdc	rpm	vdc
1500	1228	5.7	1394	6.5	1555	7.2	1701	7.9	1836	8.5
1625	1305	6.1	1457	6.8	1609	7.5	1751	8.1	1882	8.8
1750	1384	6.4	1523	7.1	1666	7.7	1803	8.4	1930	9.0
1875	1466	6.8	1592	7.4	1726	8.0	1857	8.6	1981	9.2
2000	1549	7.2	1664	7.7	1789	8.3	1914	8.9	2034	9.5
2125	1633	7.6	1738	8.1	1855	8.6	1974	9.2	2089	9.7
2250	1718	8.0	1815	8.4	1924	8.9	2036	9.5	2147	10.0
2375	1803	8.4	1894	8.8	1995	9.3	2100	9.8	—	—
2500	1890	8.8	1974	9.2	2068	9.6	—	—	—	—

CFM	AVAILABLE EXTERNAL STATIC PRESSURE (in. wg)									
	1.2		1.4		1.6		1.8		2.0	
	rpm	vdc	rpm	vdc	rpm	vdc	rpm	vdc	rpm	vdc
1500	1961	9.1	2079	9.7	—	—	—	—	—	—
1625	2004	9.3	2120	9.9	—	—	—	—	—	—
1750	2050	9.5	—	—	—	—	—	—	—	—
1875	2098	9.8	—	—	—	—	—	—	—	—
2000	2148	10.0	—	—	—	—	—	—	—	—
2125	—	—	—	—	—	—	—	—	—	—
2250	—	—	—	—	—	—	—	—	—	—
2375	—	—	—	—	—	—	—	—	—	—
2500	—	—	—	—	—	—	—	—	—	—

Standard Static 1228-2150 rpm

50GC-T06 Single Phase — Medium Static — 3 Ton Vertical Supply (rpm - vdc)

CFM	AVAILABLE EXTERNAL STATIC PRESSURE (in. wg)									
	0.2		0.4		0.6		0.8		1.0	
	rpm	vdc	rpm	vdc	rpm	vdc	rpm	vdc	rpm	vdc
1500	1228	5.1	1394	5.8	1555	6.5	1701	7.1	1836	7.7
1625	1305	5.5	1457	6.1	1609	6.7	1751	7.3	1882	7.9
1750	1384	5.8	1523	6.4	1666	7.0	1803	7.5	1930	8.1
1875	1466	6.1	1592	6.7	1726	7.2	1857	7.8	1981	8.3
2000	1549	6.5	1664	7.0	1789	7.5	1914	8.0	2034	8.5
2125	1633	6.8	1738	7.3	1855	7.8	1974	8.3	2089	8.7
2250	1718	7.2	1815	7.6	1924	8.1	2036	8.5	2147	9.0
2375	1803	7.5	1894	7.9	1995	8.3	2100	8.8	2206	9.2
2500	1890	7.9	1974	8.3	2068	8.7	2167	9.1	2268	9.5

CFM	AVAILABLE EXTERNAL STATIC PRESSURE (in. wg)									
	1.2		1.4		1.6		1.8		2.0	
	rpm	vdc	rpm	vdc	rpm	vdc	rpm	vdc	rpm	vdc
1500	1961	8.2	2079	8.7	2191	9.2	2297	9.6	—	—
1625	2004	8.4	2120	8.9	2230	9.3	2334	9.8	—	—
1750	2050	8.6	2163	9.1	2270	9.5	2373	9.9	—	—
1875	2098	8.8	2208	9.2	2314	9.7	—	—	—	—
2000	2148	9.0	2256	9.4	2359	9.9	—	—	—	—
2125	2200	9.2	2306	9.6	—	—	—	—	—	—
2250	2254	9.4	2357	9.9	—	—	—	—	—	—
2375	2310	9.7	—	—	—	—	—	—	—	—
2500	2368	9.9	—	—	—	—	—	—	—	—

Medium Static 1228-2390 rpm

50GC-J06 Three Phase — 5 Ton Vertical Supply (rpm - bhp)

CFM	AVAILABLE EXTERNAL STATIC PRESSURE (in. wg)									
	0.2		0.4		0.6		0.8		1.0	
	rpm	bhp	rpm	bhp	rpm	bhp	rpm	bhp	rpm	bhp
1500	1228	0.20	1394	0.29	1555	0.40	1701	0.53	1836	0.66
1625	1305	0.24	1457	0.33	1609	0.44	1751	0.57	1882	0.71
1750	1384	0.28	1523	0.37	1666	0.49	1803	0.62	1930	0.76
1875	1466	0.33	1592	0.43	1726	0.54	1857	0.67	1981	0.82
2000	1549	0.39	1664	0.48	1789	0.60	1914	0.74	2034	0.88
2125	1633	0.46	1738	0.55	1855	0.67	1974	0.81	2089	0.95
2250	1718	0.53	1815	0.62	1924	0.74	2036	0.88	2147	1.03
2375	1803	0.61	1894	0.71	1995	0.83	2100	0.97	2206	1.12
2500	1890	0.70	1974	0.80	2068	0.92	2167	1.06	2268	1.21

CFM	AVAILABLE EXTERNAL STATIC PRESSURE (in. wg)									
	1.2		1.4		1.6		1.8		2.0	
	rpm	bhp	rpm	bhp	rpm	bhp	rpm	bhp	rpm	bhp
1500	1961	0.80	2079	0.96	2191	1.12	2297	1.29	2399	1.47
1625	2004	0.85	2120	1.01	2230	1.18	2334	1.35	2434	1.53
1750	2050	0.91	2163	1.07	2270	1.24	2373	1.41	2472	1.60
1875	2098	0.97	2208	1.13	2314	1.31	2415	1.48	2511	1.67
2000	2148	1.04	2256	1.21	2359	1.38	2458	1.56	2553	1.75
2125	2200	1.11	2306	1.28	2407	1.46	2504	1.64	2597	1.83
2250	2254	1.20	2357	1.37	2456	1.55	2551	1.73	2643	1.93
2375	2310	1.28	2411	1.46	2507	1.64	2601	1.83	2691	2.03
2500	2368	1.38	2465	1.56	2560	1.75	2651	1.94	2740	2.14

Standard Static 1228-2150 rpm, 1.06 max bhp

Medium Static 1228-2390 rpm, 1.44 max bhp

High Static 1228-2836 rpm, 2.43 max bhp

50GC-J06 Three Phase — Standard Static — 5 Ton Vertical Supply (rpm - vdc)

CFM	AVAILABLE EXTERNAL STATIC PRESSURE (in. wg)									
	0.2		0.4		0.6		0.8		1.0	
	rpm	vdc	rpm	vdc	rpm	vdc	rpm	vdc	rpm	vdc
1500	1228	5.7	1394	6.5	1555	7.2	1701	7.9	1836	8.5
1625	1305	6.1	1457	6.8	1609	7.5	1751	8.1	1882	8.8
1750	1384	6.4	1523	7.1	1666	7.7	1803	8.4	1930	9.0
1875	1466	6.8	1592	7.4	1726	8.0	1857	8.6	1981	9.2
2000	1549	7.2	1664	7.7	1789	8.3	1914	8.9	2034	9.5
2125	1633	7.6	1738	8.1	1855	8.6	1974	9.2	2089	9.7
2250	1718	8.0	1815	8.4	1924	8.9	2036	9.5	2147	10.0
2375	1803	8.4	1894	8.8	1995	9.3	2100	9.8	—	—
2500	1890	8.8	1974	9.2	2068	9.6	—	—	—	—

CFM	AVAILABLE EXTERNAL STATIC PRESSURE (in. wg)									
	1.2		1.4		1.6		1.8		2.0	
	rpm	vdc	rpm	vdc	rpm	vdc	rpm	vdc	rpm	vdc
1500	1961	9.1	2079	9.7	—	—	—	—	—	—
1625	2004	9.3	2120	9.9	—	—	—	—	—	—
1750	2050	9.5	—	—	—	—	—	—	—	—
1875	2098	9.8	—	—	—	—	—	—	—	—
2000	2148	10.0	—	—	—	—	—	—	—	—
2125	—	—	—	—	—	—	—	—	—	—
2250	—	—	—	—	—	—	—	—	—	—
2375	—	—	—	—	—	—	—	—	—	—
2500	—	—	—	—	—	—	—	—	—	—

Standard Static 1228-2150 rpm

50GC-J06 Three Phase — Medium Static — 5 Ton Vertical Supply (rpm - vdc)

CFM	AVAILABLE EXTERNAL STATIC PRESSURE (in. wg)									
	0.2		0.4		0.6		0.8		1.0	
	rpm	vdc	rpm	vdc	rpm	vdc	rpm	vdc	rpm	vdc
1500	1228	5.1	1394	5.8	1555	6.5	1701	7.1	1836	7.7
1625	1305	5.5	1457	6.1	1609	6.7	1751	7.3	1882	7.9
1750	1384	5.8	1523	6.4	1666	7.0	1803	7.5	1930	8.1
1875	1466	6.1	1592	6.7	1726	7.2	1857	7.8	1981	8.3
2000	1549	6.5	1664	7.0	1789	7.5	1914	8.0	2034	8.5
2125	1633	6.8	1738	7.3	1855	7.8	1974	8.3	2089	8.7
2250	1718	7.2	1815	7.6	1924	8.1	2036	8.5	2147	9.0
2375	1803	7.5	1894	7.9	1995	8.3	2100	8.8	2206	9.2
2500	1890	7.9	1974	8.3	2068	8.7	2167	9.1	2268	9.5

CFM	AVAILABLE EXTERNAL STATIC PRESSURE (in. wg)									
	1.2		1.4		1.6		1.8		2.0	
	rpm	vdc	rpm	vdc	rpm	vdc	rpm	vdc	rpm	vdc
1500	1961	8.2	2079	8.7	2191	9.2	2297	9.6	—	—
1625	2004	8.4	2120	8.9	2230	9.3	2334	9.8	—	—
1750	2050	8.6	2163	9.1	2270	9.5	2373	9.9	—	—
1875	2098	8.8	2208	9.2	2314	9.7	—	—	—	—
2000	2148	9.0	2256	9.4	2359	9.9	—	—	—	—
2125	2200	9.2	2306	9.6	—	—	—	—	—	—
2250	2254	9.4	2357	9.9	—	—	—	—	—	—
2375	2310	9.7	—	—	—	—	—	—	—	—
2500	2368	9.9	—	—	—	—	—	—	—	—

Medium Static 1228-2390 rpm

50GC-J06 Three Phase — High Static — 5 Ton Vertical Supply (rpm - vdc)

CFM	AVAILABLE EXTERNAL STATIC PRESSURE (in. wg)									
	0.2		0.4		0.6		0.8		1.0	
	rpm	vdc	rpm	vdc	rpm	vdc	rpm	vdc	rpm	vdc
1500	1228	4.3	1394	4.9	1555	5.5	1701	6.0	1836	6.5
1625	1305	4.6	1457	5.1	1609	5.7	1751	6.2	1882	6.6
1750	1384	4.9	1523	5.4	1666	5.9	1803	6.4	1930	6.8
1875	1466	5.2	1592	5.6	1726	6.1	1857	6.5	1981	7.0
2000	1549	5.5	1664	5.9	1789	6.3	1914	6.7	2034	7.2
2125	1633	5.8	1738	6.1	1855	6.5	1974	7.0	2089	7.4
2250	1718	6.1	1815	6.4	1924	6.8	2036	7.2	2147	7.6
2375	1803	6.4	1894	6.7	1995	7.0	2100	7.4	2206	7.8
2500	1890	6.7	1974	7.0	2068	7.3	2167	7.6	2268	8.0

CFM	AVAILABLE EXTERNAL STATIC PRESSURE (in. wg)									
	1.2		1.4		1.6		1.8		2.0	
	rpm	vdc	rpm	vdc	rpm	vdc	rpm	vdc	rpm	vdc
1500	1961	6.9	2079	7.3	2191	7.7	2297	8.1	2399	8.5
1625	2004	7.1	2120	7.5	2230	7.9	2334	8.2	2434	8.6
1750	2050	7.2	2163	7.6	2270	8.0	2373	8.4	2472	8.7
1875	2098	7.4	2208	7.8	2314	8.2	2415	8.5	2511	8.9
2000	2148	7.6	2256	8.0	2359	8.3	2458	8.7	2553	9.0
2125	2200	7.8	2306	8.1	2407	8.5	2504	8.8	2597	9.2
2250	2254	7.9	2357	8.3	2456	8.7	2551	9.0	2643	9.3
2375	2310	8.1	2411	8.5	2507	8.8	2601	9.2	2691	9.5
2500	2368	8.3	2465	8.7	2560	9.0	2651	9.3	2740	9.7

High Static 1228-2836 rpm

50GC-T04 Single Phase — 3 Ton Horizontal Supply (rpm - bhp)

CFM	AVAILABLE EXTERNAL STATIC PRESSURE (in. wg)									
	0.2		0.4		0.6		0.8		1.0	
	rpm	bhp	rpm	bhp	rpm	bhp	rpm	bhp	rpm	bhp
900	1037	0.08	1301	0.15	1517	0.24	1697	0.34	1855	0.44
975	1076	0.09	1331	0.16	1545	0.26	1727	0.36	1885	0.47
1050	1119	0.10	1362	0.18	1573	0.27	1755	0.38	1915	0.49
1125	1164	0.11	1395	0.19	1602	0.29	1783	0.39	1944	0.51
1200	1211	0.12	1429	0.20	1632	0.30	1812	0.41	1972	0.53
1275	1261	0.14	1466	0.22	1663	0.32	1841	0.43	2000	0.56
1350	1313	0.16	1506	0.24	1695	0.34	1870	0.46	2029	0.58
1425	1366	0.18	1548	0.26	1729	0.36	1900	0.48	2058	0.61
1500	1420	0.20	1591	0.28	1765	0.38	1932	0.50	2087	0.63

CFM	AVAILABLE EXTERNAL STATIC PRESSURE (in. wg)									
	1.2		1.4		1.6		1.8		2.0	
	rpm	bhp	rpm	bhp	rpm	bhp	rpm	bhp	rpm	bhp
900	1995	0.55	2123	0.67	2241	0.78	2352	0.91	2455	1.03
975	2027	0.58	2157	0.70	2276	0.82	2387	0.95	—	—
1050	2058	0.61	2189	0.73	2309	0.86	2421	0.99	—	—
1125	2088	0.63	2219	0.76	2341	0.89	2454	1.03	—	—
1200	2117	0.66	2249	0.79	2371	0.93	2485	1.07	—	—
1275	2146	0.69	2278	0.82	2401	0.96	—	—	—	—
1350	2174	0.72	2307	0.86	2431	1.00	—	—	—	—
1425	2202	0.74	2335	0.89	2459	1.04	—	—	—	—
1500	2231	0.77	2364	0.92	2488	1.07	—	—	—	—

- Standard Static 1037-1890 rpm, 0.44 max bhp
- Medium Static 1037-2190 rpm, 0.71 max bhp
- High Static 1037-2490 rpm, 1.07 max bhp

50GC-T04 Single Phase — Standard Static — 3 Ton Horizontal Supply (rpm - vdc)

CFM	AVAILABLE EXTERNAL STATIC PRESSURE (in. wg)									
	0.2		0.4		0.6		0.8		1.0	
	rpm	vdc	rpm	vdc	rpm	vdc	rpm	vdc	rpm	vdc
900	1037	5.5	1301	6.9	1517	8.0	1697	9.0	1855	9.8
975	1076	5.7	1331	7.0	1545	8.2	1727	9.1	—	—
1050	1119	5.9	1362	7.2	1573	8.3	1755	9.3	—	—
1125	1164	6.2	1395	7.4	1602	8.5	1783	9.4	—	—
1200	1211	6.4	1429	7.6	1632	8.6	1812	9.6	—	—
1275	1261	6.7	1466	7.8	1663	8.8	1841	9.7	—	—
1350	1313	6.9	1506	8.0	1695	9.0	—	—	—	—
1425	1366	7.2	1548	8.2	1729	9.1	—	—	—	—
1500	1420	7.5	1591	8.4	1765	9.3	—	—	—	—

CFM	AVAILABLE EXTERNAL STATIC PRESSURE (in. wg)									
	1.2		1.4		1.6		1.8		2.0	
	rpm	vdc	rpm	vdc	rpm	vdc	rpm	vdc	rpm	vdc
900	—	—	—	—	—	—	—	—	—	—
975	—	—	—	—	—	—	—	—	—	—
1050	—	—	—	—	—	—	—	—	—	—
1125	—	—	—	—	—	—	—	—	—	—
1200	—	—	—	—	—	—	—	—	—	—
1275	—	—	—	—	—	—	—	—	—	—
1350	—	—	—	—	—	—	—	—	—	—
1425	—	—	—	—	—	—	—	—	—	—
1500	—	—	—	—	—	—	—	—	—	—

- Standard Static 1037-1890 rpm

50GC-T04 Single Phase — Medium Static — 3 Ton Horizontal Supply (rpm - vdc)

CFM	AVAILABLE EXTERNAL STATIC PRESSURE (in. wg)									
	0.2		0.4		0.6		0.8		1.0	
	rpm	vdc	rpm	vdc	rpm	vdc	rpm	vdc	rpm	vdc
900	1037	4.7	1301	5.9	1517	6.9	1697	7.7	1855	8.5
975	1076	4.9	1331	6.1	1545	7.1	1727	7.9	1885	8.6
1050	1119	5.1	1362	6.2	1573	7.2	1755	8.0	1915	8.7
1125	1164	5.3	1395	6.4	1602	7.3	1783	8.1	1944	8.9
1200	1211	5.5	1429	6.5	1632	7.5	1812	8.3	1972	9.0
1275	1261	5.8	1466	6.7	1663	7.6	1841	8.4	2000	9.1
1350	1313	6.0	1506	6.9	1695	7.7	1870	8.5	2029	9.3
1425	1366	6.2	1548	7.1	1729	7.9	1900	8.7	2058	9.4
1500	1420	6.5	1591	7.3	1765	8.1	1932	8.8	2087	9.5

CFM	AVAILABLE EXTERNAL STATIC PRESSURE (in. wg)									
	1.2		1.4		1.6		1.8		2.0	
	rpm	vdc	rpm	vdc	rpm	vdc	rpm	vdc	rpm	vdc
900	1995	9.1	2123	9.7	—	—	—	—	—	—
975	2027	9.3	2157	9.8	—	—	—	—	—	—
1050	2058	9.4	—	—	—	—	—	—	—	—
1125	2088	9.5	—	—	—	—	—	—	—	—
1200	2117	9.7	—	—	—	—	—	—	—	—
1275	2146	9.8	—	—	—	—	—	—	—	—
1350	—	—	—	—	—	—	—	—	—	—
1425	—	—	—	—	—	—	—	—	—	—
1500	—	—	—	—	—	—	—	—	—	—

Medium Static 1037-2190 rpm

50GC-T04 Single Phase — High Static — 3 Ton Horizontal Supply (rpm - vdc)

CFM	AVAILABLE EXTERNAL STATIC PRESSURE (in. wg)									
	0.2		0.4		0.6		0.8		1.0	
	rpm	vdc	rpm	vdc	rpm	vdc	rpm	vdc	rpm	vdc
900	1037	4.2	1301	5.2	1517	6.1	1697	6.8	1855	7.4
975	1076	4.3	1331	5.3	1545	6.2	1727	6.9	1885	7.6
1050	1119	4.5	1362	5.5	1573	6.3	1755	7.0	1915	7.7
1125	1164	4.7	1395	5.6	1602	6.4	1783	7.2	1944	7.8
1200	1211	4.9	1429	5.7	1632	6.6	1812	7.3	1972	7.9
1275	1261	5.1	1466	5.9	1663	6.7	1841	7.4	2000	8.0
1350	1313	5.3	1506	6.0	1695	6.8	1870	7.5	2029	8.1
1425	1366	5.5	1548	6.2	1729	6.9	1900	7.6	2058	8.3
1500	1420	5.7	1591	6.4	1765	7.1	1932	7.8	2087	8.4

CFM	AVAILABLE EXTERNAL STATIC PRESSURE (in. wg)									
	1.2		1.4		1.6		1.8		2.0	
	rpm	vdc	rpm	vdc	rpm	vdc	rpm	vdc	rpm	vdc
900	1995	8.0	2123	8.5	2241	9.0	2352	9.4	2455	9.9
975	2027	8.1	2157	8.7	2276	9.1	2387	9.6	—	—
1050	2058	8.3	2189	8.8	2309	9.3	2421	9.7	—	—
1125	2088	8.4	2219	8.9	2341	9.4	2454	9.9	—	—
1200	2117	8.5	2249	9.0	2371	9.5	2485	10.0	—	—
1275	2146	8.6	2278	9.1	2401	9.6	—	—	—	—
1350	2174	8.7	2307	9.3	2431	9.8	—	—	—	—
1425	2202	8.8	2335	9.4	2459	9.9	—	—	—	—
1500	2231	9.0	2364	9.5	2488	10.0	—	—	—	—

High Static 1037-2490 rpm

50GC-J04 Three Phase — 3 Ton Horizontal Supply (rpm - bhp)

CFM	AVAILABLE EXTERNAL STATIC PRESSURE (in. wg)									
	0.2		0.4		0.6		0.8		1.0	
	rpm	bhp	rpm	bhp	rpm	bhp	rpm	bhp	rpm	bhp
900	1037	0.08	1301	0.15	1517	0.24	1697	0.34	1855	0.44
975	1076	0.09	1331	0.16	1545	0.26	1727	0.36	1885	0.47
1050	1119	0.10	1362	0.18	1573	0.27	1755	0.38	1915	0.49
1125	1164	0.11	1395	0.19	1602	0.29	1783	0.39	1944	0.51
1200	1211	0.12	1429	0.20	1632	0.30	1812	0.41	1972	0.53
1275	1261	0.14	1466	0.22	1663	0.32	1841	0.43	2000	0.56
1350	1313	0.16	1506	0.24	1695	0.34	1870	0.46	2029	0.58
1425	1366	0.18	1548	0.26	1729	0.36	1900	0.48	2058	0.61
1500	1420	0.20	1591	0.28	1765	0.38	1932	0.50	2087	0.63

CFM	AVAILABLE EXTERNAL STATIC PRESSURE (in. wg)									
	1.2		1.4		1.6		1.8		2.0	
	rpm	bhp	rpm	bhp	rpm	bhp	rpm	bhp	rpm	bhp
900	1995	0.55	2123	0.67	2241	0.78	2352	0.91	2455	1.03
975	2027	0.58	2157	0.70	2276	0.82	2387	0.95	—	—
1050	2058	0.61	2189	0.73	2309	0.86	2421	0.99	—	—
1125	2088	0.63	2219	0.76	2341	0.89	2454	1.03	—	—
1200	2117	0.66	2249	0.79	2371	0.93	2485	1.07	—	—
1275	2146	0.69	2278	0.82	2401	0.96	—	—	—	—
1350	2174	0.72	2307	0.86	2431	1.00	—	—	—	—
1425	2202	0.74	2335	0.89	2459	1.04	—	—	—	—
1500	2231	0.77	2364	0.92	2488	1.07	—	—	—	—

- Standard Static 1037-1890 rpm, 0.44 max bhp
- Medium Static 1037-2190 rpm, 0.71 max bhp
- High Static 1037-2490 rpm, 1.07 max bhp

50GC-J04 Three Phase — Standard Static — 3 Ton Horizontal Supply (rpm - vdc)

CFM	AVAILABLE EXTERNAL STATIC PRESSURE (in. wg)									
	0.2		0.4		0.6		0.8		1.0	
	rpm	vdc	rpm	vdc	rpm	vdc	rpm	vdc	rpm	vdc
900	1037	5.5	1301	6.9	1517	8.0	1697	9.0	1855	9.8
975	1076	5.7	1331	7.0	1545	8.2	1727	9.1	—	—
1050	1119	5.9	1362	7.2	1573	8.3	1755	9.3	—	—
1125	1164	6.2	1395	7.4	1602	8.5	1783	9.4	—	—
1200	1211	6.4	1429	7.6	1632	8.6	1812	9.6	—	—
1275	1261	6.7	1466	7.8	1663	8.8	1841	9.7	—	—
1350	1313	6.9	1506	8.0	1695	9.0	—	—	—	—
1425	1366	7.2	1548	8.2	1729	9.1	—	—	—	—
1500	1420	7.5	1591	8.4	1765	9.3	—	—	—	—

CFM	AVAILABLE EXTERNAL STATIC PRESSURE (in. wg)									
	1.2		1.4		1.6		1.8		2.0	
	rpm	vdc	rpm	vdc	rpm	vdc	rpm	vdc	rpm	vdc
900	—	—	—	—	—	—	—	—	—	—
975	—	—	—	—	—	—	—	—	—	—
1050	—	—	—	—	—	—	—	—	—	—
1125	—	—	—	—	—	—	—	—	—	—
1200	—	—	—	—	—	—	—	—	—	—
1275	—	—	—	—	—	—	—	—	—	—
1350	—	—	—	—	—	—	—	—	—	—
1425	—	—	—	—	—	—	—	—	—	—
1500	—	—	—	—	—	—	—	—	—	—

- Standard Static 1037-1890 rpm

50GC-J04 Three Phase — Medium Static — 3 Ton Horizontal Supply (rpm - vdc)

CFM	AVAILABLE EXTERNAL STATIC PRESSURE (in. wg)									
	0.2		0.4		0.6		0.8		1.0	
	rpm	vdc	rpm	vdc	rpm	vdc	rpm	vdc	rpm	vdc
900	1037	4.7	1301	5.9	1517	6.9	1697	7.7	1855	8.5
975	1076	4.9	1331	6.1	1545	7.1	1727	7.9	1885	8.6
1050	1119	5.1	1362	6.2	1573	7.2	1755	8.0	1915	8.7
1125	1164	5.3	1395	6.4	1602	7.3	1783	8.1	1944	8.9
1200	1211	5.5	1429	6.5	1632	7.5	1812	8.3	1972	9.0
1275	1261	5.8	1466	6.7	1663	7.6	1841	8.4	2000	9.1
1350	1313	6.0	1506	6.9	1695	7.7	1870	8.5	2029	9.3
1425	1366	6.2	1548	7.1	1729	7.9	1900	8.7	2058	9.4
1500	1420	6.5	1591	7.3	1765	8.1	1932	8.8	2087	9.5

CFM	AVAILABLE EXTERNAL STATIC PRESSURE (in. wg)									
	1.2		1.4		1.6		1.8		2.0	
	rpm	vdc	rpm	vdc	rpm	vdc	rpm	vdc	rpm	vdc
900	1995	9.1	2123	9.7	—	—	—	—	—	—
975	2027	9.3	2157	9.8	—	—	—	—	—	—
1050	2058	9.4	—	—	—	—	—	—	—	—
1125	2088	9.5	—	—	—	—	—	—	—	—
1200	2117	9.7	—	—	—	—	—	—	—	—
1275	2146	9.8	—	—	—	—	—	—	—	—
1350	—	—	—	—	—	—	—	—	—	—
1425	—	—	—	—	—	—	—	—	—	—
1500	—	—	—	—	—	—	—	—	—	—

Medium Static 1037-2190 rpm

50GC-J04 Three Phase — High Static — 3 Ton Horizontal Supply (rpm - vdc)

CFM	AVAILABLE EXTERNAL STATIC PRESSURE (in. wg)									
	0.2		0.4		0.6		0.8		1.0	
	rpm	vdc	rpm	vdc	rpm	vdc	rpm	vdc	rpm	vdc
900	1037	4.2	1301	5.2	1517	6.1	1697	6.8	1855	7.4
975	1076	4.3	1331	5.3	1545	6.2	1727	6.9	1885	7.6
1050	1119	4.5	1362	5.5	1573	6.3	1755	7.0	1915	7.7
1125	1164	4.7	1395	5.6	1602	6.4	1783	7.2	1944	7.8
1200	1211	4.9	1429	5.7	1632	6.6	1812	7.3	1972	7.9
1275	1261	5.1	1466	5.9	1663	6.7	1841	7.4	2000	8.0
1350	1313	5.3	1506	6.0	1695	6.8	1870	7.5	2029	8.1
1425	1366	5.5	1548	6.2	1729	6.9	1900	7.6	2058	8.3
1500	1420	5.7	1591	6.4	1765	7.1	1932	7.8	2087	8.4

CFM	AVAILABLE EXTERNAL STATIC PRESSURE (in. wg)									
	1.2		1.4		1.6		1.8		2.0	
	rpm	vdc	rpm	vdc	rpm	vdc	rpm	vdc	rpm	vdc
900	1995	8.0	2123	8.5	2241	9.0	2352	9.4	2455	9.9
975	2027	8.1	2157	8.7	2276	9.1	2387	9.6	—	—
1050	2058	8.3	2189	8.8	2309	9.3	2421	9.7	—	—
1125	2088	8.4	2219	8.9	2341	9.4	2454	9.9	—	—
1200	2117	8.5	2249	9.0	2371	9.5	2485	10.0	—	—
1275	2146	8.6	2278	9.1	2401	9.6	—	—	—	—
1350	2174	8.7	2307	9.3	2431	9.8	—	—	—	—
1425	2202	8.8	2335	9.4	2459	9.9	—	—	—	—
1500	2231	9.0	2364	9.5	2488	10.0	—	—	—	—

High Static 1037-2490 rpm

50GC-T05 Single Phase — 4 Ton Horizontal Supply (rpm - bhp)

CFM	AVAILABLE EXTERNAL STATIC PRESSURE (in. wg)									
	0.2		0.4		0.6		0.8		1.0	
	rpm	bhp	rpm	bhp	rpm	bhp	rpm	bhp	rpm	bhp
1200	1092	0.14	1306	0.24	1497	0.35	1667	0.49	1819	0.64
1300	1148	0.16	1348	0.26	1533	0.38	1700	0.52	1851	0.67
1400	1207	0.18	1394	0.28	1571	0.41	1734	0.55	1882	0.70
1500	1267	0.21	1442	0.31	1612	0.44	1770	0.58	1916	0.73
1600	1329	0.24	1493	0.35	1655	0.47	1808	0.61	1951	0.77
1700	1393	0.28	1546	0.38	1700	0.51	1848	0.65	1988	0.81
1800	1458	0.32	1602	0.42	1748	0.55	1890	0.70	2026	0.86
1900	1523	0.36	1659	0.47	1797	0.60	1934	0.75	2066	0.91
2000	1590	0.41	1719	0.52	1849	0.65	1980	0.80	2108	0.96

CFM	AVAILABLE EXTERNAL STATIC PRESSURE (in. wg)									
	1.2		1.4		1.6		1.8		2.0	
	rpm	bhp	rpm	bhp	rpm	bhp	rpm	bhp	rpm	bhp
1200	1958	0.79	2089	0.96	2211	1.14	2327	1.33	2438	1.53
1300	1988	0.83	2117	1.00	2238	1.18	2352	1.37	—	—
1400	2020	0.86	2146	1.03	2266	1.22	2379	1.41	—	—
1500	2051	0.90	2177	1.08	2296	1.26	2408	1.46	—	—
1600	2084	0.94	2209	1.12	2327	1.31	2438	1.51	—	—
1700	2119	0.99	2242	1.17	2358	1.36	—	—	—	—
1800	2154	1.03	2276	1.22	2391	1.41	—	—	—	—
1900	2191	1.08	2311	1.27	2424	1.47	—	—	—	—
2000	2230	1.14	2347	1.33	2459	1.53	—	—	—	—

Standard Static 1092-1900 rpm, 0.72 max bhp

Medium Static 1092-2170 rpm, 1.06 max bhp

High Static 1092-2460 rpm, 1.53 max bhp

50GC-T05 Single Phase — Standard Static — 4 Ton Horizontal Supply (rpm - vdc)

CFM	AVAILABLE EXTERNAL STATIC PRESSURE (in. wg)									
	0.2		0.4		0.6		0.8		1.0	
	rpm	vdc	rpm	vdc	rpm	vdc	rpm	vdc	rpm	vdc
1200	1092	5.7	1306	6.9	1497	7.9	1667	8.8	1819	9.6
1300	1148	6.0	1348	7.1	1533	8.1	1700	8.9	1851	9.7
1400	1207	6.4	1394	7.3	1571	8.3	1734	9.1	1882	9.9
1500	1267	6.7	1442	7.6	1612	8.5	1770	9.3	—	—
1600	1329	7.0	1493	7.9	1655	8.7	1808	9.5	—	—
1700	1393	7.3	1546	8.1	1700	8.9	1848	9.7	—	—
1800	1458	7.7	1602	8.4	1748	9.2	1890	9.9	—	—
1900	1523	8.0	1659	8.7	1797	9.5	—	—	—	—
2000	1590	8.4	1719	9.0	1849	9.7	—	—	—	—

CFM	AVAILABLE EXTERNAL STATIC PRESSURE (in. wg)									
	1.2		1.4		1.6		1.8		2.0	
	rpm	vdc	rpm	vdc	rpm	vdc	rpm	vdc	rpm	vdc
1200	—	—	—	—	—	—	—	—	—	—
1300	—	—	—	—	—	—	—	—	—	—
1400	—	—	—	—	—	—	—	—	—	—
1500	—	—	—	—	—	—	—	—	—	—
1600	—	—	—	—	—	—	—	—	—	—
1700	—	—	—	—	—	—	—	—	—	—
1800	—	—	—	—	—	—	—	—	—	—
1900	—	—	—	—	—	—	—	—	—	—
2000	—	—	—	—	—	—	—	—	—	—

Standard Static 1092-1900 rpm

50GC-T05 Single Phase — Medium Static — 4 Ton Horizontal Supply (rpm - vdc)

CFM	AVAILABLE EXTERNAL STATIC PRESSURE (in. wg)									
	0.2		0.4		0.6		0.8		1.0	
	rpm	vdc	rpm	vdc	rpm	vdc	rpm	vdc	rpm	vdc
1200	1092	5.0	1306	6.0	1497	6.9	1667	7.7	1819	8.4
1300	1148	5.3	1348	6.2	1533	7.1	1700	7.8	1851	8.5
1400	1207	5.6	1394	6.4	1571	7.2	1734	8.0	1882	8.7
1500	1267	5.8	1442	6.6	1612	7.4	1770	8.2	1916	8.8
1600	1329	6.1	1493	6.9	1655	7.6	1808	8.3	1951	9.0
1700	1393	6.4	1546	7.1	1700	7.8	1848	8.5	1988	9.2
1800	1458	6.7	1602	7.4	1748	8.1	1890	8.7	2026	9.3
1900	1523	7.0	1659	7.6	1797	8.3	1934	8.9	2066	9.5
2000	1590	7.3	1719	7.9	1849	8.5	1980	9.1	2108	9.7

CFM	AVAILABLE EXTERNAL STATIC PRESSURE (in. wg)									
	1.2		1.4		1.6		1.8		2.0	
	rpm	vdc	rpm	vdc	rpm	vdc	rpm	vdc	rpm	vdc
1200	1958	9.0	2089	9.6	—	—	—	—	—	—
1300	1988	9.2	2117	9.8	—	—	—	—	—	—
1400	2020	9.3	2146	9.9	—	—	—	—	—	—
1500	2051	9.5	—	—	—	—	—	—	—	—
1600	2084	9.6	—	—	—	—	—	—	—	—
1700	2119	9.8	—	—	—	—	—	—	—	—
1800	2154	9.9	—	—	—	—	—	—	—	—
1900	—	—	—	—	—	—	—	—	—	—
2000	—	—	—	—	—	—	—	—	—	—

Medium Static 1092-2170 rpm

50GC-T05 Single Phase — High Static — 4 Ton Horizontal Supply (rpm - vdc)

CFM	AVAILABLE EXTERNAL STATIC PRESSURE (in. wg)									
	0.2		0.4		0.6		0.8		1.0	
	rpm	vdc	rpm	vdc	rpm	vdc	rpm	vdc	rpm	vdc
1200	1092	4.4	1306	5.3	1497	6.1	1667	6.8	1819	7.4
1300	1148	4.7	1348	5.5	1533	6.2	1700	6.9	1851	7.5
1400	1207	4.9	1394	5.7	1571	6.4	1734	7.0	1882	7.7
1500	1267	5.2	1442	5.9	1612	6.6	1770	7.2	1916	7.8
1600	1329	5.4	1493	6.1	1655	6.7	1808	7.3	1951	7.9
1700	1393	5.7	1546	6.3	1700	6.9	1848	7.5	1988	8.1
1800	1458	5.9	1602	6.5	1748	7.1	1890	7.7	2026	8.2
1900	1523	6.2	1659	6.7	1797	7.3	1934	7.9	2066	8.4
2000	1590	6.5	1719	7.0	1849	7.5	1980	8.0	2108	8.6

CFM	AVAILABLE EXTERNAL STATIC PRESSURE (in. wg)									
	1.2		1.4		1.6		1.8		2.0	
	rpm	vdc	rpm	vdc	rpm	vdc	rpm	vdc	rpm	vdc
1200	1958	8.0	2089	8.5	2211	9.0	2327	9.5	2438	9.9
1300	1988	8.1	2117	8.6	2238	9.1	2352	9.6	—	—
1400	2020	8.2	2146	8.7	2266	9.2	2379	9.7	—	—
1500	2051	8.3	2177	8.8	2296	9.3	2408	9.8	—	—
1600	2084	8.5	2209	9.0	2327	9.5	2438	9.9	—	—
1700	2119	8.6	2242	9.1	2358	9.6	—	—	—	—
1800	2154	8.8	2276	9.3	2391	9.7	—	—	—	—
1900	2191	8.9	2311	9.4	2424	9.9	—	—	—	—
2000	2230	9.1	2347	9.5	2459	10.0	—	—	—	—

High Static 1092-2460 rpm

50GC-J05 Three Phase — 4 Ton Horizontal Supply (rpm - bhp)

CFM	AVAILABLE EXTERNAL STATIC PRESSURE (in. wg)									
	0.2		0.4		0.6		0.8		1.0	
	rpm	bhp	rpm	bhp	rpm	bhp	rpm	bhp	rpm	bhp
1200	1092	0.14	1306	0.24	1497	0.35	1667	0.49	1819	0.64
1300	1148	0.16	1348	0.26	1533	0.38	1700	0.52	1851	0.67
1400	1207	0.18	1394	0.28	1571	0.41	1734	0.55	1882	0.70
1500	1267	0.21	1442	0.31	1612	0.44	1770	0.58	1916	0.73
1600	1329	0.24	1493	0.35	1655	0.47	1808	0.61	1951	0.77
1700	1393	0.28	1546	0.38	1700	0.51	1848	0.65	1988	0.81
1800	1458	0.32	1602	0.42	1748	0.55	1890	0.70	2026	0.86
1900	1523	0.36	1659	0.47	1797	0.60	1934	0.75	2066	0.91
2000	1590	0.41	1719	0.52	1849	0.65	1980	0.80	2108	0.96

CFM	AVAILABLE EXTERNAL STATIC PRESSURE (in. wg)									
	1.2		1.4		1.6		1.8		2.0	
	rpm	bhp	rpm	bhp	rpm	bhp	rpm	bhp	rpm	bhp
1200	1958	0.79	2089	0.96	2211	1.14	2327	1.33	2438	1.53
1300	1988	0.83	2117	1.00	2238	1.18	2352	1.37	2462	1.57
1400	2020	0.86	2146	1.03	2266	1.22	2379	1.41	2487	1.61
1500	2051	0.90	2177	1.08	2296	1.26	2408	1.46	2515	1.66
1600	2084	0.94	2209	1.12	2327	1.31	2438	1.51	2544	1.71
1700	2119	0.99	2242	1.17	2358	1.36	2469	1.56	2574	1.77
1800	2154	1.03	2276	1.22	2391	1.41	2500	1.61	2604	1.82
1900	2191	1.08	2311	1.27	2424	1.47	2533	1.68	2636	1.89
2000	2230	1.14	2347	1.33	2459	1.53	2566	1.74	—	—

- Standard Static 1092-1900 rpm, 0.72 max bhp
- Medium Static 1092-2170 rpm, 1.06 max bhp
- High Static 1092-2660 rpm, 1.96 max bhp

50GC-J05 Three Phase — Standard Static — 4 Ton Horizontal Supply (rpm - vdc)

CFM	AVAILABLE EXTERNAL STATIC PRESSURE (in. wg)									
	0.2		0.4		0.6		0.8		1.0	
	rpm	vdc	rpm	vdc	rpm	vdc	rpm	vdc	rpm	vdc
1200	1092	5.7	1306	6.9	1497	7.9	1667	8.8	1819	9.6
1300	1148	6.0	1348	7.1	1533	8.1	1700	8.9	1851	9.7
1400	1207	6.4	1394	7.3	1571	8.3	1734	9.1	1882	9.9
1500	1267	6.7	1442	7.6	1612	8.5	1770	9.3	—	—
1600	1329	7.0	1493	7.9	1655	8.7	1808	9.5	—	—
1700	1393	7.3	1546	8.1	1700	8.9	1848	9.7	—	—
1800	1458	7.7	1602	8.4	1748	9.2	1890	9.9	—	—
1900	1523	8.0	1659	8.7	1797	9.5	—	—	—	—
2000	1590	8.4	1719	9.0	1849	9.7	—	—	—	—

CFM	AVAILABLE EXTERNAL STATIC PRESSURE (in. wg)									
	1.2		1.4		1.6		1.8		2.0	
	rpm	vdc	rpm	vdc	rpm	vdc	rpm	vdc	rpm	vdc
1200	—	—	—	—	—	—	—	—	—	—
1300	—	—	—	—	—	—	—	—	—	—
1400	—	—	—	—	—	—	—	—	—	—
1500	—	—	—	—	—	—	—	—	—	—
1600	—	—	—	—	—	—	—	—	—	—
1700	—	—	—	—	—	—	—	—	—	—
1800	—	—	—	—	—	—	—	—	—	—
1900	—	—	—	—	—	—	—	—	—	—
2000	—	—	—	—	—	—	—	—	—	—

- Standard Static 1092-1900 rpm

50GC-J05 Three Phase — Medium Static — 4 Ton Horizontal Supply (rpm - vdc)

CFM	AVAILABLE EXTERNAL STATIC PRESSURE (in. wg)									
	0.2		0.4		0.6		0.8		1.0	
	rpm	vdc	rpm	vdc	rpm	vdc	rpm	vdc	rpm	vdc
1200	1092	5.0	1306	6.0	1497	6.9	1667	7.7	1819	8.4
1300	1148	5.3	1348	6.2	1533	7.1	1700	7.8	1851	8.5
1400	1207	5.6	1394	6.4	1571	7.2	1734	8.0	1882	8.7
1500	1267	5.8	1442	6.6	1612	7.4	1770	8.2	1916	8.8
1600	1329	6.1	1493	6.9	1655	7.6	1808	8.3	1951	9.0
1700	1393	6.4	1546	7.1	1700	7.8	1848	8.5	1988	9.2
1800	1458	6.7	1602	7.4	1748	8.1	1890	8.7	2026	9.3
1900	1523	7.0	1659	7.6	1797	8.3	1934	8.9	2066	9.5
2000	1590	7.3	1719	7.9	1849	8.5	1980	9.1	2108	9.7

CFM	AVAILABLE EXTERNAL STATIC PRESSURE (in. wg)									
	1.2		1.4		1.6		1.8		2.0	
	rpm	vdc	rpm	vdc	rpm	vdc	rpm	vdc	rpm	vdc
1200	1958	9.0	2089	9.6	—	—	—	—	—	—
1300	1988	9.2	2117	9.8	—	—	—	—	—	—
1400	2020	9.3	2146	9.9	—	—	—	—	—	—
1500	2051	9.5	—	—	—	—	—	—	—	—
1600	2084	9.6	—	—	—	—	—	—	—	—
1700	2119	9.8	—	—	—	—	—	—	—	—
1800	2154	9.9	—	—	—	—	—	—	—	—
1900	—	—	—	—	—	—	—	—	—	—
2000	—	—	—	—	—	—	—	—	—	—

Medium Static 1092-2170 rpm

50GC-J05 Three Phase — High Static — 4 Ton Horizontal Supply (rpm - vdc)

CFM	AVAILABLE EXTERNAL STATIC PRESSURE (in. wg)									
	0.2		0.4		0.6		0.8		1.0	
	rpm	vdc	rpm	vdc	rpm	vdc	rpm	vdc	rpm	vdc
1200	1092	4.1	1306	4.9	1497	5.6	1667	6.3	1819	6.8
1300	1148	4.3	1348	5.1	1533	5.8	1700	6.4	1851	7.0
1400	1207	4.5	1394	5.2	1571	5.9	1734	6.5	1882	7.1
1500	1267	4.8	1442	5.4	1612	6.1	1770	6.7	1916	7.2
1600	1329	5.0	1493	5.6	1655	6.2	1808	6.8	1951	7.3
1700	1393	5.2	1546	5.8	1700	6.4	1848	6.9	1988	7.5
1800	1458	5.5	1602	6.0	1748	6.6	1890	7.1	2026	7.6
1900	1523	5.7	1659	6.2	1797	6.8	1934	7.3	2066	7.8
2000	1590	6.0	1719	6.5	1849	7.0	1980	7.4	2108	7.9

CFM	AVAILABLE EXTERNAL STATIC PRESSURE (in. wg)									
	1.2		1.4		1.6		1.8		2.0	
	rpm	vdc	rpm	vdc	rpm	vdc	rpm	vdc	rpm	vdc
1200	1958	7.4	2089	7.9	2211	8.3	2327	8.7	2438	9.2
1300	1988	7.5	2117	8.0	2238	8.4	2352	8.8	2462	9.3
1400	2020	7.6	2146	8.1	2266	8.5	2379	8.9	2487	9.3
1500	2051	7.7	2177	8.2	2296	8.6	2408	9.1	2515	9.5
1600	2084	7.8	2209	8.3	2327	8.7	2438	9.2	2544	9.6
1700	2119	8.0	2242	8.4	2358	8.9	2469	9.3	2574	9.7
1800	2154	8.1	2276	8.6	2391	9.0	2500	9.4	2604	9.8
1900	2191	8.2	2311	8.7	2424	9.1	2533	9.5	2636	9.9
2000	2230	8.4	2347	8.8	2459	9.2	2566	9.6	—	—

High Static 1092-2660 rpm

50GC-T06 Single Phase — 5 Ton Horizontal Supply (rpm - bhp)

CFM	AVAILABLE EXTERNAL STATIC PRESSURE (in. wg)									
	0.2		0.4		0.6		0.8		1.0	
	rpm	bhp	rpm	bhp	rpm	bhp	rpm	bhp	rpm	bhp
1500	1197	0.18	1361	0.26	1524	0.36	1679	0.49	1822	0.62
1625	1271	0.21	1421	0.29	1574	0.40	1721	0.52	1860	0.66
1750	1347	0.25	1485	0.33	1627	0.44	1767	0.56	1901	0.70
1875	1425	0.29	1552	0.38	1684	0.49	1816	0.61	1945	0.75
2000	1504	0.35	1622	0.43	1745	0.54	1869	0.66	1992	0.80
2125	1584	0.40	1695	0.49	1809	0.60	1926	0.72	2043	0.86
2250	1665	0.47	1769	0.56	1876	0.67	1986	0.79	2096	0.93
2375	1747	0.54	1844	0.63	1945	0.74	2048	0.87	2153	1.01
2500	1830	0.62	1921	0.71	2016	0.82	2114	0.95	2213	1.09

CFM	AVAILABLE EXTERNAL STATIC PRESSURE (in. wg)									
	1.2		1.4		1.6		1.8		2.0	
	rpm	bhp	rpm	bhp	rpm	bhp	rpm	bhp	rpm	bhp
1500	1954	0.77	2078	0.92	2194	1.09	2303	1.26	—	—
1625	1990	0.81	2112	0.97	2227	1.13	2336	1.31	—	—
1750	2028	0.85	2148	1.01	2262	1.18	2369	1.36	—	—
1875	2068	0.90	2186	1.06	2298	1.23	—	—	—	—
2000	2111	0.95	2226	1.12	2335	1.29	—	—	—	—
2125	2157	1.02	2268	1.18	2375	1.36	—	—	—	—
2250	2206	1.08	2313	1.25	—	—	—	—	—	—
2375	2257	1.16	2360	1.32	—	—	—	—	—	—
2500	2312	1.24	—	—	—	—	—	—	—	—

Standard Static 1197-2150 rpm, 1.06 max bhp

Medium Static 1197-2390 rpm, 1.44 max bhp

50GC-T06 Single Phase — Standard Static — 5 Ton Horizontal Supply (rpm - vdc)

CFM	AVAILABLE EXTERNAL STATIC PRESSURE (in. wg)									
	0.2		0.4		0.6		0.8		1.0	
	rpm	vdc	rpm	vdc	rpm	vdc	rpm	vdc	rpm	vdc
1500	1197	5.6	1361	6.3	1524	7.1	1679	7.8	1822	8.5
1625	1271	5.9	1421	6.6	1574	7.3	1721	8.0	1860	8.7
1750	1348	6.3	1486	6.9	1627	7.6	1767	8.2	1901	8.8
1875	1426	6.6	1552	7.2	1684	7.8	1816	8.4	1945	9.0
2000	1505	7.0	1623	7.5	1745	8.1	1870	8.7	1992	9.3
2125	1585	7.4	1695	7.9	1809	8.4	1926	9.0	2043	9.5
2250	1666	7.7	1769	8.2	1876	8.7	1986	9.2	2096	9.7
2375	1748	8.1	1845	8.6	1945	9.0	2049	9.5	—	—
2500	1830	8.5	1921	8.9	2016	9.4	2114	9.8	—	—

CFM	AVAILABLE EXTERNAL STATIC PRESSURE (in. wg)									
	1.2		1.4		1.6		1.8		2.0	
	rpm	vdc	rpm	vdc	rpm	vdc	rpm	vdc	rpm	vdc
1500	1955	9.1	2078	9.7	—	—	—	—	—	—
1625	1990	9.3	2112	9.8	—	—	—	—	—	—
1750	2028	9.4	2148	10.0	—	—	—	—	—	—
1875	2069	9.6	—	—	—	—	—	—	—	—
2000	2111	9.8	—	—	—	—	—	—	—	—
2125	—	—	—	—	—	—	—	—	—	—
2250	—	—	—	—	—	—	—	—	—	—
2375	—	—	—	—	—	—	—	—	—	—
2500	—	—	—	—	—	—	—	—	—	—

Standard Static 1197-2150 rpm

50GC-T06 Single Phase — Medium Static — 5 Ton Horizontal Supply (rpm - vdc)

CFM	AVAILABLE EXTERNAL STATIC PRESSURE (in. wg)									
	0.2		0.4		0.6		0.8		1.0	
	rpm	vdc	rpm	vdc	rpm	vdc	rpm	vdc	rpm	vdc
1500	1197	5.0	1361	5.7	1524	6.4	1679	7.0	1822	7.6
1625	1271	5.3	1421	5.9	1574	6.6	1721	7.2	1860	7.8
1750	1348	5.6	1486	6.2	1627	6.8	1767	7.4	1901	8.0
1875	1426	6.0	1552	6.5	1684	7.0	1816	7.6	1945	8.1
2000	1505	6.3	1623	6.8	1745	7.3	1870	7.8	1992	8.3
2125	1585	6.6	1695	7.1	1809	7.6	1926	8.1	2043	8.5
2250	1666	7.0	1769	7.4	1876	7.8	1986	8.3	2096	8.8
2375	1748	7.3	1845	7.7	1945	8.1	2049	8.6	2153	9.0
2500	1830	7.7	1921	8.0	2016	8.4	2114	8.8	2213	9.3

CFM	AVAILABLE EXTERNAL STATIC PRESSURE (in. wg)									
	1.2		1.4		1.6		1.8		2.0	
	rpm	vdc	rpm	vdc	rpm	vdc	rpm	vdc	rpm	vdc
1500	1955	8.2	2078	8.7	2194	9.2	2304	9.6	—	—
1625	1990	8.3	2112	8.8	2227	9.3	2336	9.8	—	—
1750	2028	8.5	2148	9.0	2262	9.5	2370	9.9	—	—
1875	2069	8.7	2186	9.1	2298	9.6	—	—	—	—
2000	2111	8.8	2226	9.3	2336	9.8	—	—	—	—
2125	2157	9.0	2268	9.5	2375	9.9	—	—	—	—
2250	2206	9.2	2313	9.7	—	—	—	—	—	—
2375	2258	9.4	2361	9.9	—	—	—	—	—	—
2500	2312	9.7	—	—	—	—	—	—	—	—

Medium Static 1197-2390 rpm

50GC-J06 Three Phase — 5 Ton Horizontal Supply (rpm - bhp)

CFM	AVAILABLE EXTERNAL STATIC PRESSURE (in. wg)									
	0.2		0.4		0.6		0.8		1.0	
	rpm	bhp	rpm	bhp	rpm	bhp	rpm	bhp	rpm	bhp
1500	1197	0.18	1361	0.26	1524	0.36	1679	0.49	1822	0.62
1625	1271	0.21	1421	0.29	1574	0.40	1721	0.52	1860	0.66
1750	1348	0.25	1486	0.34	1627	0.44	1767	0.56	1901	0.70
1875	1426	0.30	1552	0.38	1684	0.49	1816	0.61	1945	0.75
2000	1505	0.35	1623	0.43	1745	0.54	1870	0.66	1992	0.80
2125	1585	0.40	1695	0.49	1809	0.60	1926	0.72	2043	0.86
2250	1666	0.47	1769	0.56	1876	0.67	1986	0.79	2096	0.93
2375	1748	0.54	1845	0.63	1945	0.74	2049	0.87	2153	1.01
2500	1830	0.62	1921	0.71	2016	0.82	2114	0.95	2213	1.09

CFM	AVAILABLE EXTERNAL STATIC PRESSURE (in. wg)									
	1.2		1.4		1.6		1.8		2.0	
	rpm	bhp	rpm	bhp	rpm	bhp	rpm	bhp	rpm	bhp
1500	1955	0.77	2078	0.92	2194	1.09	2304	1.26	2408	1.44
1625	1990	0.81	2112	0.97	2227	1.13	2336	1.31	2440	1.49
1750	2028	0.85	2148	1.01	2262	1.18	2370	1.36	2472	1.54
1875	2069	0.90	2186	1.06	2298	1.23	2404	1.41	2506	1.60
2000	2111	0.95	2226	1.12	2336	1.29	2441	1.48	2541	1.66
2125	2157	1.02	2268	1.18	2375	1.36	2479	1.54	2578	1.73
2250	2206	1.08	2313	1.25	2417	1.43	2518	1.61	2616	1.81
2375	2258	1.16	2361	1.33	2462	1.50	2560	1.69	2656	1.89
2500	2312	1.24	2411	1.41	2509	1.59	2604	1.78	2697	1.97

- Standard Static 1197-2150 rpm, 1.06 max bhp
- Medium Static 1197-2390 rpm, 1.44 max bhp
- High Static 1197-2836 rpm, 2.43 max bhp

50GC-J06 Three Phase — Standard Static — 5 Ton Horizontal Supply (rpm - vdc)

CFM	AVAILABLE EXTERNAL STATIC PRESSURE (in. wg)									
	0.2		0.4		0.6		0.8		1.0	
	rpm	vdc	rpm	vdc	rpm	vdc	rpm	vdc	rpm	vdc
1500	1197	5.6	1361	6.3	1524	7.1	1679	7.8	1822	8.5
1625	1271	5.9	1421	6.6	1574	7.3	1721	8.0	1860	8.7
1750	1348	6.3	1486	6.9	1627	7.6	1767	8.2	1901	8.8
1875	1426	6.6	1552	7.2	1684	7.8	1816	8.4	1945	9.0
2000	1505	7.0	1623	7.5	1745	8.1	1870	8.7	1992	9.3
2125	1585	7.4	1695	7.9	1809	8.4	1926	9.0	2043	9.5
2250	1666	7.7	1769	8.2	1876	8.7	1986	9.2	2096	9.7
2375	1748	8.1	1845	8.6	1945	9.0	2049	9.5	—	—
2500	1830	8.5	1921	8.9	2016	9.4	2114	9.8	—	—

CFM	AVAILABLE EXTERNAL STATIC PRESSURE (in. wg)									
	1.2		1.4		1.6		1.8		2.0	
	rpm	vdc	rpm	vdc	rpm	vdc	rpm	vdc	rpm	vdc
1500	1955	9.1	2078	9.7	—	—	—	—	—	—
1625	1990	9.3	2112	9.8	—	—	—	—	—	—
1750	2028	9.4	2148	10.0	—	—	—	—	—	—
1875	2069	9.6	—	—	—	—	—	—	—	—
2000	2111	9.8	—	—	—	—	—	—	—	—
2125	—	—	—	—	—	—	—	—	—	—
2250	—	—	—	—	—	—	—	—	—	—
2375	—	—	—	—	—	—	—	—	—	—
2500	—	—	—	—	—	—	—	—	—	—

- Standard Static 1197-2150 rpm

50GC-J06 Three Phase — Medium Static — 5 Ton Horizontal Supply (rpm - VDC)

CFM	AVAILABLE EXTERNAL STATIC PRESSURE (in. wg)									
	0.2		0.4		0.6		0.8		1.0	
	rpm	vdc	rpm	vdc	rpm	vdc	rpm	vdc	rpm	vdc
1500	1197	5.0	1361	5.7	1524	6.4	1679	7.0	1822	7.6
1625	1271	5.3	1421	5.9	1574	6.6	1721	7.2	1860	7.8
1750	1348	5.6	1486	6.2	1627	6.8	1767	7.4	1901	8.0
1875	1426	6.0	1552	6.5	1684	7.0	1816	7.6	1945	8.1
2000	1505	6.3	1623	6.8	1745	7.3	1870	7.8	1992	8.3
2125	1585	6.6	1695	7.1	1809	7.6	1926	8.1	2043	8.5
2250	1666	7.0	1769	7.4	1876	7.8	1986	8.3	2096	8.8
2375	1748	7.3	1845	7.7	1945	8.1	2049	8.6	2153	9.0
2500	1830	7.7	1921	8.0	2016	8.4	2114	8.8	2213	9.3

CFM	AVAILABLE EXTERNAL STATIC PRESSURE (in. wg)									
	1.2		1.4		1.6		1.8		2.0	
	rpm	vdc	rpm	vdc	rpm	vdc	rpm	vdc	rpm	vdc
1500	1955	8.2	2078	8.7	2194	9.2	2304	9.6	—	—
1625	1990	8.3	2112	8.8	2227	9.3	2336	9.8	—	—
1750	2028	8.5	2148	9.0	2262	9.5	2370	9.9	—	—
1875	2069	8.7	2186	9.1	2298	9.6	—	—	—	—
2000	2111	8.8	2226	9.3	2336	9.8	—	—	—	—
2125	2157	9.0	2268	9.5	2375	9.9	—	—	—	—
2250	2206	9.2	2313	9.7	—	—	—	—	—	—
2375	2258	9.4	2361	9.9	—	—	—	—	—	—
2500	2312	9.7	—	—	—	—	—	—	—	—

Medium Static 1197-2390 rpm

50GC-J06 Three Phase — High Static — 5 Ton Horizontal Supply (rpm - vdc)

CFM	AVAILABLE EXTERNAL STATIC PRESSURE (in. wg)									
	0.2		0.4		0.6		0.8		1.0	
	rpm	vdc	rpm	vdc	rpm	vdc	rpm	vdc	rpm	vdc
1500	1197	4.2	1361	4.8	1524	5.4	1679	5.9	1822	6.4
1625	1271	4.5	1421	5.0	1574	5.6	1721	6.1	1860	6.6
1750	1348	4.8	1486	5.2	1627	5.7	1767	6.2	1901	6.7
1875	1426	5.0	1552	5.5	1684	5.9	1816	6.4	1945	6.9
2000	1505	5.3	1623	5.7	1745	6.2	1870	6.6	1992	7.0
2125	1585	5.6	1695	6.0	1809	6.4	1926	6.8	2043	7.2
2250	1666	5.9	1769	6.2	1876	6.6	1986	7.0	2096	7.4
2375	1748	6.2	1845	6.5	1945	6.9	2049	7.2	2153	7.6
2500	1830	6.5	1921	6.8	2016	7.1	2114	7.5	2213	7.8

CFM	AVAILABLE EXTERNAL STATIC PRESSURE (in. wg)									
	1.2		1.4		1.6		1.8		2.0	
	rpm	vdc	rpm	vdc	rpm	vdc	rpm	vdc	rpm	vdc
1500	1955	6.9	2078	7.3	2194	7.7	2304	8.1	2408	8.5
1625	1990	7.0	2112	7.4	2227	7.9	2336	8.2	2440	8.6
1750	2028	7.2	2148	7.6	2262	8.0	2370	8.4	2472	8.7
1875	2069	7.3	2186	7.7	2298	8.1	2404	8.5	2506	8.8
2000	2111	7.4	2226	7.8	2336	8.2	2441	8.6	2541	9.0
2125	2157	7.6	2268	8.0	2375	8.4	2479	8.7	2578	9.1
2250	2206	7.8	2313	8.2	2417	8.5	2518	8.9	2616	9.2
2375	2258	8.0	2361	8.3	2462	8.7	2560	9.0	2656	9.4
2500	2312	8.2	2411	8.5	2509	8.8	2604	9.2	2697	9.5

High Static 1197-2836 rpm

Legend and Notes

Applicable for Electrical Data Tables on pages 94-118

LEGEND

BRKR	— Circuit Breaker
CO	— Convenience Outlet
FLA	— Full Load Amps
IFM	— Indoor Fan Motor
LRA	— Locked Rotor Amps
MCA	— Minimum Circuit Amps
PE	— Power Exhaust
Pwr'd fr/unit	— Powered From Unit
PWRD CO	— Powered Convenience Outlet
RLA	— Rated Load Amps
UNPWR CO	— Unpowered Convenience Outlet

NOTES:

1. In compliance with NEC requirements for multi-motor and combination load equipment (refer to NEC Articles 430 and 440), the overcurrent protective device for the unit shall be fuse or HACR breaker. Canadian units may be fuse or circuit breaker.
2. For 208/230 v units, where one value is show it is the same for either 208 or 230 volts.
3. **Unbalanced 3-Phase Supply Voltage:** Never operate a motor where a phase imbalance in supply voltage is greater than 2%. Use the following formula to determine the percentage of voltage imbalance.

$$\% \text{ Voltage Imbalance} = 100 \times \frac{\text{max voltage deviation from average voltage}}{\text{average voltage}}$$

Example: Supply voltage is 230-3-60

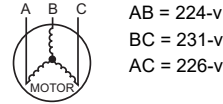

$$\text{Average Voltage} = \frac{(224 + 231 + 226)}{3} = \frac{681}{3} = 227$$

Determine maximum deviation from average voltage.

(AB) 227-224 = 3-v

(BC) 231-227 = 4-v

(AC) 227-226 = 1-v

Maximum deviation is 4-v.

Determine percent of voltage imbalance.

$$\% \text{ Voltage Imbalance} = 100 \times \frac{4}{227} = 1.76\%$$

This amount of phase imbalance is satisfactory as it is below the maximum allowable 2%.

IMPORTANT: If the supply voltage phase imbalance is more than 2%, contact your local electric utility company immediately.

48/50GC**04-06 Cooling Electrical Data

48/50GC UNIT	V-Ph-Hz	UNIT VOLTAGE		COMPRESSOR		OFM (ea)		IFM			COMBUSTION FAN MOTOR (48GC only)	POWER EXHAUST	
		Range		RLA	LRA	Watts	FLA	Type	Effcy at Full Load	FLA	FLA	Kit Qty	FLA (ea kit)
		Min	Max										
**04	208/230-1-60	187	253	15.4	92	275	2.6	STD	84%	3.4	0.48	1	1.9
						275	2.6	MED	84%	5.1			
						275	2.6	HIGH	85%	7.3			
	208/230-3-60	187	253	10.1	88	275	2.6	STD	84%	3.4	0.48	1	1.9
						275	2.6	MED	84%	5.1			
						275	2.6	HIGH	85%	7.3			
	460-3-60	414	506	4.7	44	275	1.4	STD	85%	0.9	0.25	1	1.0
						275	1.4	MED	85%	1.2			
						275	1.4	HIGH	84%	1.5			
	575-3-60	518	633	3.8	29	275	2.6	STD	84%	0.8	0.24	1	1.9
						275	2.6	MED	84%	1.1			
						275	2.6	HIGH	85%	1.5			
**05	208/230-1-60	187	253	19.9	127	275	2.6	STD	87%	5.0	0.48	1	1.9
						275	2.6	MED	86%	7.1			
						275	2.6	HIGH	84%	8.8			
	208/230-3-60	187	253	12.9	105	275	2.6	STD	87%	5.0	0.48	1	1.9
						275	2.6	MED	86%	7.1			
						275	2.6	HIGH	85%	5.1			
	460-3-60	414	506	7.1	62	275	1.4	STD	85%	1.2	0.25	1	1.0
						275	1.4	MED	86%	1.5			
						275	1.4	HIGH	88%	2.4			
	575-3-60	518	633	4.6	39	275	2.6	STD	84%	1.1	0.24	1	1.9
						275	2.6	MED	85%	1.5			
						275	2.6	HIGH	88%	2.1			
**06	208/230-1-60	187	253	25.6	158	275	2.6	STD	86%	7.2	0.48	1	1.9
						275	2.6	MED	84%	8.6			
	208/230-3-60	187	253	16.4	110	275	2.6	STD	86%	7.2	0.48	1	1.9
						275	2.6	MED	84%	8.6			
						275	2.6	HIGH	84%	6.4			
	460-3-60	414	506	6.9	55	275	1.4	STD	86%	1.5	0.25	1	1.0
						275	1.4	MED	86%	1.9			
						275	1.4	HIGH	88%	2.9			
	575-3-60	518	633	6.4	48	275	2.6	STD	84%	1.5	0.24	1	1.9
						275	2.6	MED	85%	1.8			
						275	2.6	HIGH	87%	2.5			

48GC**04-06 MCA MOCP Electrical Data

48GC UNIT SIZE	NOM. V-Ph-Hz	IFM TYPE	NO CONVENIENCE OUTLET OR UNPOWERED CONVENIENCE OUTLET							
			No Power Exhaust				With Power Exhaust (powered from unit)			
			MCA	Fuse or HACR Breaker	Disconnect Size		MCA	Fuse or HACR Breaker	Disconnect Size	
					FLA	LRA			FLA	LRA
**04	208/230-1-60	STD	26	30	25	101	28	40	27	103
		MED	27	40	27	103	29	40	29	105
		HIGH	30	40	29	106	32	45	31	108
	208/230-3-60	STD	19	25	19	97	21	30	21	99
		MED	21	30	20	99	23	30	23	101
		HIGH	23	30	23	102	25	30	25	104
	460-3-60	STD	9	15	8	47	10	15	9	48
		MED	9	15	8	48	10	15	10	49
		HIGH	9	15	9	48	10	15	10	49
	575-3-60	STD	9	15	8	34	11	15	10	36
		MED	9	15	9	35	11	15	11	37
		HIGH	9	15	9	35	11	15	11	37
**05	208/230-1-60	STD	33	50	32	138	35	50	34	140
		MED	35	50	34	141	37	50	36	143
		HIGH	37	50	36	143	39	50	38	145
	208/230-3-60	STD	24	30	24	116	26	30	26	118
		MED	26	30	26	119	28	40	28	121
		HIGH	24	30	24	116	26	30	26	118
	460-3-60	STD	12	15	11	66	13	15	12	67
		MED	12	15	12	66	13	15	13	67
		HIGH	13	15	13	67	14	20	14	68
	575-3-60	STD	10	15	10	45	12	15	12	47
		MED	10	15	10	45	12	15	12	47
		HIGH	11	15	11	46	13	15	13	48
**06	208/230-1-60	STD	42	60	41	172	44	60	43	174
		MED	44	60	42	174	46	60	45	176
	208/230-3-60	STD	31	45	30	124	33	45	32	126
		MED	32	45	32	126	34	50	34	128
		HIGH	30	45	29	123	32	45	31	125
	460-3-60	STD	12	15	11	59	13	15	12	60
		MED	12	15	12	60	13	15	13	61
		HIGH	13	15	13	61	14	20	14	62
	575-3-60	STD	13	15	12	54	14	20	14	56
		MED	13	15	12	55	15	20	15	57
		HIGH	14	15	13	56	15	20	15	58

48GC**04-06 MCA MOCP Electrical Data (cont)

48GC UNIT SIZE	NOM. V-Ph-Hz	IFM TYPE	WITH POWERED CONVENIENCE OUTLET							
			No Power Exhaust				With Power Exhaust (powered from unit)			
			MCA	Fuse or HACR Breaker	Disconnect Size		MCA	Fuse or HACR Breaker	Disconnect Size	
					FLA	LRA			FLA	LRA
**04	208/230-3-60	STD	24	30	24	102	26	30	26	104
		MED	26	30	26	104	27	30	28	106
		HIGH	28	30	29	107	30	35	31	109
	460-3-60	STD	11	15	11	49	12	15	12	50
		MED	11	15	11	50	12	15	12	51
		HIGH	11	15	11	50	12	15	12	51
	575-3-60	STD	10	15	10	36	12	15	12	38
		MED	11	15	11	37	13	15	13	39
		HIGH	11	15	11	37	13	15	13	39
**05	208/230-3-60	STD	29	40	29	121	31	40	31	123
		MED	31	40	32	124	33	45	34	126
		HIGH	29	40	29	121	31	40	31	123
	460-3-60	STD	14	20	14	68	15	20	15	69
		MED	14	20	14	68	15	20	15	69
		HIGH	15	20	15	69	16	20	16	70
	575-3-60	STD	12	15	12	47	14	15	14	49
		MED	12	15	12	47	14	15	14	49
		HIGH	13	15	13	48	15	20	15	50
**06	208/230-3-60	STD	36	50	36	129	37	50	38	131
		MED	37	50	37	131	39	50	39	133
		HIGH	35	50	35	128	37	50	37	130
	460-3-60	STD	14	20	14	61	15	20	15	62
		MED	15	20	14	62	16	20	15	63
		HIGH	16	20	15	63	17	20	17	64
	575-3-60	STD	14	20	14	56	16	20	16	58
		MED	15	20	14	57	16	20	17	59
		HIGH	15	20	15	58	17	20	17	60

48GC**04-06 MCA MOCP Electrical Data with Factory-Installed HACR Breaker

48GC UNIT SIZE	NOM. V-Ph-Hz	IFM TYPE	NO CONVENIENCE OUTLET OR UNPOWERED CONVENIENCE OUTLET							
			No Power Exhaust				With Power Exhaust (powered from unit)			
			MCA	HACR Breaker	Disconnect Size		MCA	HACR Breaker	Disconnect Size	
					FLA	LRA			FLA	LRA
**04	208/230-1-60	STD	26	30	25	101	28	40	27	103
		MED	27	40	27	103	29	40	29	105
		HIGH	30	40	29	106	32	45	31	108
	208/230-3-60	STD	19	25	19	97	21	30	21	99
		MED	21	30	20	99	23	30	23	101
		HIGH	23	30	23	102	25	30	25	104
	460-3-60	STD	9	15	8	47	10	15	9	48
		MED	9	15	8	48	10	15	10	49
		HIGH	9	15	9	48	10	15	10	49
	575-3-60	STD	9	15	8	34	11	15	10	36
		MED	9	15	9	35	11	15	11	37
		HIGH	9	15	9	35	11	15	11	37
**05	208/230-1-60	STD	33	50	32	138	35	50	34	140
		MED	35	50	34	141	37	50	36	143
		HIGH	37	50	36	143	39	50	38	145
	208/230-3-60	STD	24	30	24	116	26	30	26	118
		MED	26	30	26	119	28	40	28	121
		HIGH	24	30	24	116	26	30	26	118
	460-3-60	STD	12	15	11	66	13	15	12	67
		MED	12	15	12	66	13	15	13	67
		HIGH	13	15	13	67	14	20	14	68
	575-3-60	STD	10	15	10	45	12	15	12	47
		MED	10	15	10	45	12	15	12	47
		HIGH	11	15	11	46	13	15	13	48
**06	208/230-1-60	STD	42	60	41	172	44	60	43	174
		MED	44	60	42	174	46	60	45	176
	208/230-3-60	STD	31	45	30	124	33	45	32	126
		MED	32	45	32	126	34	50	34	128
		HIGH	30	45	29	123	32	45	31	125
	460-3-60	STD	12	15	11	59	13	15	12	60
		MED	12	15	12	60	13	15	13	61
		HIGH	13	15	13	61	14	20	14	62
	575-3-60	STD	13	15	12	54	14	20	14	56
		MED	13	15	12	55	15	20	15	57
		HIGH	14	15	13	56	15	20	15	58

48GC**04-06 MCA MOCP Electrical Data with Factory-Installed HACR Breaker (cont)

48GC UNIT SIZE	NOM. V-Ph-Hz	IFM TYPE	WITH POWERED CONVENIENCE OUTLET							
			No Power Exhaust				With Power Exhaust (powered from unit)			
			MCA	HACR Breaker	Disconnect Size		MCA	HACR Breaker	Disconnect Size	
					FLA	LRA			FLA	LRA
**04	208/230-3-60	STD	24	30	24	102	26	30	26	104
		MED	26	30	26	104	27	30	28	106
		HIGH	28	30	29	107	30	35	31	109
	460-3-60	STD	11	15	11	49	12	15	12	50
		MED	11	15	11	50	12	15	12	51
		HIGH	11	15	11	50	12	15	12	51
	575-3-60	STD	10	15	10	36	12	15	12	38
		MED	11	15	11	37	13	15	13	39
		HIGH	11	15	11	37	13	15	13	39
**05	208/230-3-60	STD	29	40	29	121	31	40	31	123
		MED	31	40	32	124	33	45	34	126
		HIGH	29	40	29	121	31	40	31	123
	460-3-60	STD	14	20	14	68	15	20	15	69
		MED	14	20	14	68	15	20	15	69
		HIGH	15	20	15	69	16	20	16	70
	575-3-60	STD	12	15	12	47	14	15	14	49
		MED	12	15	12	47	14	15	14	49
		HIGH	13	15	13	48	15	20	15	50
**06	208/230-3-60	STD	36	50	36	129	37	50	38	131
		MED	37	50	37	131	39	50	39	133
		HIGH	35	50	35	128	37	50	37	130
	460-3-60	STD	14	20	14	61	15	20	15	62
		MED	15	20	14	62	16	20	15	63
		HIGH	16	20	15	63	17	20	17	64
	575-3-60	STD	14	20	14	56	16	20	16	58
		MED	15	20	14	57	16	20	17	59
		HIGH	15	20	15	58	17	20	17	60

50GC**04 MCA MOCAP Electrical Data

50GC UNIT SIZE	NOM. V-Ph-Hz	IFM TYPE	ELECTRIC HEATER			NO CONVENIENCE OUTLET OR UNPOWERED CONVENIENCE OUTLET							
			CRHEATER ***A00	NOM (kW)	FLA	No Power Exhaust				With Power Exhaust (powered from unit)			
						MCA	Fuse or HACR BRKR	Disconnect Size		MCA	Fuse or HACR BRKR	Disconnect Size	
								FLA	LRA			FLA	LRA
208/230-1-60	STD	NONE	—	—	26	30	25	101	28	40	27	103	
		323A	3.3/4.4	15.9/18.3	26/28	30/30	25/25	101/101	28/30	40/40	27/27	103/103	
		324A	4.9/6.5	23.5/27.1	34/39	40/40	31/35	101/101	36/41	40/45	33/37	103/103	
		325A	6.5/8.7	31.4/36.3	44/50	45/50	40/46	101/101	46/52	50/60	42/48	103/103	
		326A	7.9/10.5	37.9/43.8	52/59	60/60	47/54	101/101	54/62	60/70	50/56	103/103	
		327A	9.8/13.0	46.9/54.2	63/72	70/80	58/66	101/101	66/75	70/80	60/68	103/103	
	MED	NONE	—	—	27	40	27	103	29	40	29	105	
		323A	3.3/4.4	15.9/18.3	27/30	40/40	27/27	103/103	29/32	40/40	29/29	105/105	
		324A	4.9/6.5	23.5/27.1	36/41	40/45	33/37	103/103	39/43	40/45	35/39	105/105	
		325A	6.5/8.7	31.4/36.3	46/52	50/60	42/48	103/103	48/55	50/60	44/50	105/105	
		326A	7.9/10.5	37.9/43.8	54/62	60/70	49/56	103/103	57/64	60/70	52/58	105/105	
		327A	9.8/13.0	46.9/54.2	65/75	70/80	60/68	103/103	68/77	70/80	62/70	105/105	
	HIGH	NONE	—	—	30	40	29	106	32	45	31	108	
		323A	3.3/4.4	15.9/18.3	30/32	40/40	29/29	106/106	32/35	45/45	31/32	108/108	
		324A	4.9/6.5	23.5/27.1	39/43	40/45	35/40	106/106	41/46	45/50	38/42	108/108	
		325A	6.5/8.7	31.4/36.3	49/55	50/60	45/50	106/106	51/57	60/60	47/52	108/108	
		326A	7.9/10.5	37.9/43.8	57/64	60/70	52/59	106/106	59/67	60/70	54/61	108/108	
		327A	9.8/13.0	46.9/54.2	68/77	70/80	62/71	106/106	71/80	80/80	65/73	108/108	
208/230-3-60	STD	NONE	—	—	19	25	19	97	21	30	21	99	
		323A	3.3/4.4	9.2/10.6	19/19	25/25	19/19	97/97	21/21	30/30	21/21	99/99	
		324A	4.9/6.5	13.6/15.6	22/24	25/25	20/22	97/97	24/27	30/30	22/24	99/99	
		325A	6.5/8.7	18.1/20.9	27/31	30/35	25/28	97/97	30/33	30/35	27/30	99/99	
		326A	7.9/10.5	21.9/25.3	32/36	35/40	29/33	97/97	34/39	35/40	31/35	99/99	
		328A	12.0/16.0	33.4/38.5	46/53	50/60	42/48	97/97	49/55	50/60	45/50	99/99	
	MED	NONE	—	—	21	30	20	99	23	30	23	101	
		323A	3.3/4.4	9.2/10.6	21/21	30/30	20/20	99/99	23/23	30/30	23/23	101/101	
		324A	4.9/6.5	13.6/15.6	24/26	30/30	22/24	99/99	26/29	30/30	24/26	101/101	
		325A	6.5/8.7	18.1/20.9	29/33	30/35	27/30	99/99	32/35	35/35	29/32	101/101	
		326A	7.9/10.5	21.9/25.3	34/38	35/40	31/35	99/99	37/41	40/45	33/37	101/101	
		328A	12.0/16.0	33.4/38.5	49/55	50/60	44/50	99/99	51/57	60/60	46/52	101/101	
	HIGH	NONE	—	—	23	30	23	102	25	30	25	104	
		323A	3.3/4.4	9.2/10.6	23/23	30/30	23/23	102/102	25/25	30/30	25/25	104/104	
		324A	4.9/6.5	13.6/15.6	27/29	30/30	24/26	102/102	29/31	30/35	26/29	104/104	
		325A	6.5/8.7	18.1/20.9	32/36	35/40	29/32	102/102	35/38	35/40	31/35	104/104	
		326A	7.9/10.5	21.9/25.3	37/41	40/45	34/37	102/102	39/44	40/45	36/40	104/104	
		328A	12.0/16.0	33.4/38.5	51/58	60/60	47/53	102/102	54/60	60/60	49/55	104/104	
460-3-60	STD	NONE	—	—	9	15	8	47	10	15	9	48	
		333A	6.0	7.2	11	15	9	47	12	15	10	48	
		334A	8.8	10.6	15	15	13	47	16	20	14	48	
		335A	11.5	13.8	19	20	17	47	20	20	18	48	
		336A	14.0	16.8	23	25	20	47	24	25	22	48	
		NONE	—	—	9	15	8	48	10	15	10	49	
	MED	333A	6.0	7.2	11	15	10	48	12	15	11	49	
		334A	8.8	10.6	15	15	14	48	16	20	15	49	
		335A	11.5	13.8	19	20	17	48	20	25	18	49	
		336A	14.0	16.8	23	25	21	48	24	25	22	49	
		NONE	—	—	9	15	9	48	10	15	10	49	
		HIGH	333A	6.0	7.2	11	15	10	48	13	15	11	49
	334A		8.8	10.6	16	20	14	48	17	20	15	49	
	335A		11.5	13.8	20	20	18	48	21	25	19	49	
	336A		14.0	16.8	23	25	21	48	25	25	22	49	
	NONE		—	—	9	15	8	34	11	15	10	36	
	575-3-60		STD	339A	10.0	9.6	13	15	12	34	16	20	14
		340A		15.0	14.4	19	20	17	34	22	25	20	36
NONE		—		—	9	15	9	35	11	15	11	37	
MED		339A	10.0	9.6	14	15	12	35	16	20	14	37	
		340A	15.0	14.4	20	20	18	35	22	25	20	37	
		NONE	—	—	9	15	9	35	11	15	11	37	
HIGH		339A	10.0	9.6	14	15	13	35	17	20	15	37	
		340A	15.0	14.4	20	20	18	35	23	25	20	37	
		NONE	—	—	9	15	9	35	11	15	11	37	

50GC**04 MCA MOC P Electrical Data (cont)

50GC UNIT SIZE	NOM. V-Ph-Hz	IFM TYPE	ELECTRIC HEATER			WITH POWERED CONVENIENCE OUTLET								
			CRHEATER ***A00	NOM (kW)	FLA	No Power Exhaust				With Power Exhaust (powered from unit)				
						MCA	Fuse or HACR BRKR	Disconnect Size		MCA	Fuse or HACR BRKR	Disconnect Size		
								FLA	LRA			FLA	LRA	
	208/230-3-60	STD	NONE	—	—	24	30	24	102	26	30	26	104	
			323A	3.3/4.4	9.2/10.6	24/24	30/30	24/24	102/102	26/26	30/30	26/26	104/104	
			324A	4.9/6.5	13.6/15.6	28/30	30/30	25/27	102/102	30/33	30/35	27/30	104/104	
			325A	6.5/8.7	18.1/20.9	33/37	35/40	30/33	102/102	36/39	40/40	32/36	104/104	
			326A	7.9/10.5	21.9/25.3	38/42	40/45	35/39	102/102	40/45	45/45	37/41	104/104	
			328A	12.0/16.0	33.4/38.5	52/59	60/60	48/54	102/102	55/61	60/70	50/56	104/104	
		MED	NONE	—	—	26	30	26	104	27	30	28	106	
			323A	3.3/4.4	9.2/10.6	26/26	30/30	26/26	104/104	27/28	30/30	28/28	106/106	
			324A	4.9/6.5	13.6/15.6	30/32	30/35	27/29	104/104	32/35	35/35	29/32	106/106	
			325A	6.5/8.7	18.1/20.9	35/39	40/40	32/35	104/104	38/41	40/45	34/38	106/106	
			326A	7.9/10.5	21.9/25.3	40/44	40/45	37/40	104/104	43/47	45/50	39/43	106/106	
			328A	12.0/16.0	33.4/38.5	55/61	60/70	50/56	104/104	57/63	60/70	52/58	106/106	
		HIGH	NONE	—	—	28	30	29	107	30	35	31	109	
			323A	3.3/4.4	9.2/10.6	28/29	30/30	29/29	107/107	30/31	35/35	31/31	109/109	
			324A	4.9/6.5	13.6/15.6	33/35	35/35	30/32	107/107	35/37	35/40	32/34	109/109	
			325A	6.5/8.7	18.1/20.9	38/42	40/45	35/38	107/107	41/44	45/45	37/40	109/109	
			326A	7.9/10.5	21.9/25.3	43/47	45/50	39/43	107/107	45/50	45/50	41/45	109/109	
			328A	12.0/16.0	33.4/38.5	57/64	60/70	52/58	107/107	60/66	60/70	55/60	109/109	
	**04	460-3-60	STD	NONE	—	—	11	15	11	49	12	15	12	50
				333A	6.0	7.2	13	15	12	49	15	15	13	50
				334A	8.8	10.6	18	20	16	49	19	20	17	50
				335A	11.5	13.8	22	25	19	49	23	25	21	50
				336A	14.0	16.8	25	25	23	49	27	30	24	50
			MED	NONE	—	—	11	15	11	50	12	15	12	51
333A				6.0	7.2	14	15	12	50	15	15	13	51	
334A				8.8	10.6	18	20	16	50	19	20	17	51	
335A				11.5	13.8	22	25	20	50	23	25	21	51	
336A				14.0	16.8	26	30	23	50	27	30	24	51	
HIGH			NONE	—	—	11	15	11	50	12	15	12	51	
			333A	6.0	7.2	14	15	13	50	15	15	14	51	
		334A	8.8	10.6	18	20	16	50	20	20	18	51		
		335A	11.5	13.8	22	25	20	50	24	25	21	51		
		336A	14.0	16.8	26	30	24	50	27	30	25	51		
575-3-60		STD	NONE	—	—	10	15	10	36	12	15	12	38	
			339A	10.0	9.6	16	20	14	36	18	20	16	38	
			340A	15.0	14.4	22	25	19	36	24	25	22	38	
		MED	NONE	—	—	11	15	11	37	13	15	13	39	
			339A	10.0	9.6	16	20	14	37	18	20	16	39	
			340A	15.0	14.4	22	25	20	37	24	25	22	39	
		HIGH	NONE	—	—	11	15	11	37	13	15	13	39	
			339A	10.0	9.6	16	20	15	37	19	20	17	39	
			340A	15.0	14.4	22	25	20	37	25	25	22	39	

50GC**04 MCA MOCPP Electrical Data with Factory-Installed HACR Breaker

50GC UNIT SIZE	NOM. V-Ph-Hz	IFM TYPE	ELECTRIC HEATER			NO CONVENIENCE OUTLET OR UNPOWERED CONVENIENCE OUTLET							
			CRHEATER ***A00	NOM (kW)	FLA	No Power Exhaust				With Power Exhaust (powered from unit)			
						MCA	HACR BRKR	Disconnect Size		MCA	HACR BRKR	Disconnect Size	
								FLA	LRA			FLA	LRA
208/230-1-60		STD	NONE	—	—	26	30	25	101	28	40	27	103
			323A	3.3/4.4	15.9/18.3	28/28	30/30	25/25	101/101	30/30	40/40	27/27	103/103
			324A	4.9/6.5	23.5/27.1	39/39	40/40	31/35	101/101	41/41	45/45	33/37	103/103
			325A	6.5/8.7	31.4/36.3	50/50	50/50	40/46	101/101	52/52	60/60	42/48	103/103
			326A	7.9/10.5	37.9/43.8	59/59	60/60	47/54	101/101	62/62	70/70	50/56	103/103
			327A	9.8/13.0	46.9/54.2	72/72	80/80	58/66	101/101	75/75	80/80	60/68	103/103
		MED	NONE	—	—	27	40	27	103	29	40	29	105
			323A	3.3/4.4	15.9/18.3	30/30	40/40	27/27	103/103	32/32	40/40	29/29	105/105
			324A	4.9/6.5	23.5/27.1	41/41	45/45	33/37	103/103	43/43	45/45	35/39	105/105
			325A	6.5/8.7	31.4/36.3	52/52	60/60	42/48	103/103	55/55	60/60	44/50	105/105
			326A	7.9/10.5	37.9/43.8	62/62	70/70	49/56	103/103	64/64	70/70	52/58	105/105
			327A	9.8/13.0	46.9/54.2	75/75	80/80	60/68	103/103	77/77	80/80	62/70	105/105
		HIGH	NONE	—	—	30	40	29	106	32	45	31	108
			323A	3.3/4.4	15.9/18.3	32/32	40/40	29/29	106/106	35/35	45/45	31/32	108/108
			324A	4.9/6.5	23.5/27.1	43/43	45/45	35/40	106/106	46/46	50/50	38/42	108/108
			325A	6.5/8.7	31.4/36.3	55/55	60/60	45/50	106/106	57/57	60/60	47/52	108/108
			326A	7.9/10.5	37.9/43.8	64/64	70/70	52/59	106/106	67/67	70/70	54/61	108/108
			327A	9.8/13.0	46.9/54.2	77/77	80/80	62/71	106/106	80/80	80/80	65/73	108/108
208/230-3-60		STD	NONE	—	—	19	25	19	97	21	30	21	99
			323A	3.3/4.4	9.2/10.6	19/19	25/25	19/19	97/97	21/21	30/30	21/21	99/99
			324A	4.9/6.5	13.6/15.6	24/24	25/25	20/22	97/97	27/27	30/30	22/24	99/99
			325A	6.5/8.7	18.1/20.9	31/31	35/35	25/28	97/97	33/33	35/35	27/30	99/99
			326A	7.9/10.5	21.9/25.3	36/36	40/40	29/33	97/97	39/39	40/40	31/35	99/99
			328A	12.0/16.0	33.4/38.5	53/53	60/60	42/48	97/97	55/55	60/60	45/50	99/99
		MED	NONE	—	—	21	30	20	99	23	30	23	101
			323A	3.3/4.4	9.2/10.6	21/21	30/30	20/20	99/99	23/23	30/30	23/23	101/101
			324A	4.9/6.5	13.6/15.6	26/26	30/30	22/24	99/99	29/29	30/30	24/26	101/101
			325A	6.5/8.7	18.1/20.9	33/33	35/35	27/30	99/99	35/35	35/35	29/32	101/101
			326A	7.9/10.5	21.9/25.3	38/38	40/40	31/35	99/99	41/41	45/45	33/37	101/101
			328A	12.0/16.0	33.4/38.5	55/55	60/60	44/50	99/99	57/57	60/60	46/52	101/101
		HIGH	NONE	—	—	23	30	23	102	25	30	25	104
			323A	3.3/4.4	9.2/10.6	23/23	30/30	23/23	102/102	25/25	30/30	25/25	104/104
			324A	4.9/6.5	13.6/15.6	29/29	30/30	24/26	102/102	31/31	35/35	26/29	104/104
			325A	6.5/8.7	18.1/20.9	36/36	40/40	29/32	102/102	38/38	40/40	31/35	104/104
			326A	7.9/10.5	21.9/25.3	41/41	45/45	34/37	102/102	44/44	45/45	36/40	104/104
			328A	12.0/16.0	33.4/38.5	58/58	60/60	47/53	102/102	60/60	60/60	49/55	104/104
460-3-60		STD	NONE	—	—	9	15	8	47	10	15	9	48
			333A	6.0	7.2	11	15	9	47	12	15	10	48
			334A	8.8	10.6	15	15	13	47	16	20	14	48
			335A	11.5	13.8	19	20	17	47	20	20	18	48
		MED	336A	14.0	16.8	23	25	20	47	24	25	22	48
			NONE	—	—	9	15	8	48	10	15	10	49
			333A	6.0	7.2	11	15	10	48	12	15	11	49
			334A	8.8	10.6	15	15	14	48	16	20	15	49
		HIGH	335A	11.5	13.8	19	20	17	48	20	25	18	49
			336A	14.0	16.8	23	25	21	48	24	25	22	49
			NONE	—	—	9	15	9	48	10	15	10	49
			333A	6.0	7.2	11	15	10	48	13	15	11	49
575-3-60		STD	334A	8.8	10.6	15	15	14	48	16	20	15	49
			335A	11.5	13.8	19	20	17	48	20	25	18	49
			336A	14.0	16.8	23	25	21	48	25	25	22	49
		MED	NONE	—	—	9	15	9	35	11	15	11	37
			339A	10.0	9.6	14	15	12	35	16	20	14	37
			340A	15.0	14.4	20	20	18	35	22	25	20	37
		HIGH	NONE	—	—	9	15	9	35	11	15	11	37
			339A	10.0	9.6	14	15	13	35	17	20	15	37
			340A	15.0	14.4	20	20	18	35	23	25	20	37

50GC**04 MCA MOCPP Electrical Data with Factory-Installed HACR Breaker (cont)

50GC UNIT SIZE	NOM. V-Ph-Hz	IFM TYPE	ELECTRIC HEATER			WITH POWERED CONVENIENCE OUTLET									
			CRHEATER ***A00	NOM (KW)	FLA	No Power Exhaust				With Power Exhaust (powered from unit)					
						MCA	HACR BRKR	Disconnect Size		MCA	HACR BRKR	Disconnect Size			
								FLA	LRA			FLA	LRA		
**04	208/230-3-60	STD	NONE	—	—	24	30	24	102	26	30	26	104		
			323A	3.3/4.4	9.2/10.6	24/24	30/30	24/24	102/102	26/26	30/30	26/26	104/104		
			324A	4.9/6.5	13.6/15.6	30/30	30/30	25/27	102/102	33/33	35/35	27/30	104/104		
			325A	6.5/8.7	18.1/20.9	37/37	40/40	30/33	102/102	39/39	40/40	32/36	104/104		
			326A	7.9/10.5	21.9/25.3	42/42	45/45	35/39	102/102	45/45	45/45	37/41	104/104		
			328A	12.0/16.0	33.4/38.5	59/59	60/60	48/54	102/102	61/61	70/70	50/56	104/104		
		MED	NONE	—	—	26	30	26	104	27	30	28	106		
			323A	3.3/4.4	9.2/10.6	26/26	30/30	26/26	104/104	28/28	30/30	28/28	106/106		
			324A	4.9/6.5	13.6/15.6	32/32	35/35	27/29	104/104	35/35	35/35	29/32	106/106		
			325A	6.5/8.7	18.1/20.9	39/39	40/40	32/35	104/104	41/41	45/45	34/38	106/106		
			326A	7.9/10.5	21.9/25.3	44/44	45/45	37/40	104/104	47/47	50/50	39/43	106/106		
			328A	12.0/16.0	33.4/38.5	61/61	70/70	50/56	104/104	63/63	70/70	52/58	106/106		
		HIGH	NONE	—	—	28	30	29	107	30	35	31	109		
			323A	3.3/4.4	9.2/10.6	29/29	30/30	29/29	107/107	31/31	35/35	31/31	109/109		
			324A	4.9/6.5	13.6/15.6	35/35	35/35	30/32	107/107	37/37	40/40	32/34	109/109		
			325A	6.5/8.7	18.1/20.9	42/42	45/45	35/38	107/107	44/44	45/45	37/40	109/109		
			326A	7.9/10.5	21.9/25.3	47/47	50/50	39/43	107/107	50/50	50/50	41/45	109/109		
			328A	12.0/16.0	33.4/38.5	64/64	70/70	52/58	107/107	66/66	70/70	55/60	109/109		
	460-3-60	STD	NONE	—	—	11	15	11	49	12	15	12	50		
			333A	6.0	7.2	13	15	12	49	15	15	13	50		
			334A	8.8	10.6	18	20	16	49	19	20	17	50		
			335A	11.5	13.8	22	25	19	49	23	25	21	50		
			336A	14.0	16.8	25	25	23	49	27	30	24	50		
			NONE	—	—	11	15	11	50	12	15	12	51		
		MED	333A	6.0	7.2	14	15	12	50	15	15	13	51		
			334A	8.8	10.6	18	20	16	50	19	20	17	51		
			335A	11.5	13.8	22	25	20	50	23	25	21	51		
			336A	14.0	16.8	26	30	23	50	27	30	24	51		
			NONE	—	—	11	15	11	50	12	15	12	51		
			333A	6.0	7.2	14	15	13	50	15	15	14	51		
		HIGH	334A	8.8	10.6	18	20	16	50	20	20	18	51		
			335A	11.5	13.8	22	25	20	50	24	25	21	51		
			336A	14.0	16.8	26	30	24	50	27	30	25	51		
			NONE	—	—	10	15	10	36	12	15	12	38		
			575-3-60	STD	339A	10.0	9.6	16	20	14	36	18	20	16	38
					340A	15.0	14.4	22	25	19	36	24	25	22	38
NONE	—	—			11	15	11	37	13	15	13	39			
MED	339A	10.0		9.6	16	20	14	37	18	20	16	39			
	340A	15.0		14.4	22	25	20	37	24	25	22	39			
	NONE	—		—	11	15	11	37	13	15	13	39			
HIGH	339A	10.0	9.6	16	20	15	37	19	20	17	39				
	340A	15.0	14.4	22	25	20	37	25	25	22	39				
	NONE	—	—	11	15	11	37	13	15	13	39				

50GC**05 MCA MOCOP Electrical Data

50GC UNIT SIZE	NOM. V-Ph-Hz	IFM TYPE	ELECTRIC HEATER			NO CONVENIENCE OUTLET OR UNPOWERED CONVENIENCE OUTLET							
			CRHEATER ***A00	NOM (kW)	FLA	No Power Exhaust				With Power Exhaust (powered from unit)			
						MCA	Fuse or HACR BRKR	Disconnect Size		MCA	Fuse or HACR BRKR	Disconnect Size	
								FLA	LRA			FLA	LRA
**05	208/230-1-60	STD	NONE	—	—	33	50	32	138	35	50	34	140
			323A	3.3/4.4	15.9/18.3	33/33	50/50	32/32	138/138	35/35	50/50	34/34	140/140
			325A	6.5/8.7	31.4/36.3	46/52	50/60	42/47	138/138	48/54	50/60	44/50	140/140
			327A	9.8/13.0	46.9/54.2	65/74	70/80	60/68	138/138	68/77	70/80	62/70	140/140
			329A	13.1/17.4	62.8/72.5	85/97	90/100	78/89	138/138	88/100	90/100	80/91	140/140
			330A	14.4/19.2	69.3/80.0	93/107	100/110	85/98	138/138	96/109	100/110	88/100	140/140
			331A	15.8/21.0	75.8/87.5	101/116	110/125	93/106	138/138	104/118	110/125	95/109	140/140
			326A	7.9/10.5	37.9/43.8	54/61	60/70	49/56	138/138	56/64	60/70	52/58	140/140
		MED	NONE	—	—	35	50	34	141	37	50	36	143
			323A	3.3/4.4	15.9/18.3	35/35	50/50	34/34	141/141	37/37	50/50	36/36	143/143
			325A	6.5/8.7	31.4/36.3	49/55	50/60	44/50	141/141	51/57	60/60	46/52	143/143
			327A	9.8/13.0	46.9/54.2	68/77	70/80	62/70	141/141	70/79	70/80	64/73	143/143
			329A	13.1/17.4	62.8/72.5	88/100	90/100	80/92	141/141	90/102	90/110	83/94	143/143
			330A	14.4/19.2	69.3/80.0	96/109	100/110	88/100	141/141	98/112	100/125	90/102	143/143
			331A	15.8/21.0	75.8/87.5	104/119	110/125	95/109	141/141	106/121	110/125	98/111	143/143
			326A	7.9/10.5	37.9/43.8	57/64	60/70	52/59	141/141	59/66	60/70	54/61	143/143
		HIGH	NONE	—	—	37	50	36	143	39	50	38	145
			323A	3.3/4.4	15.9/18.3	37/37	50/50	36/36	143/143	39/39	50/50	38/38	145/145
			325A	6.5/8.7	31.4/36.3	51/57	60/60	46/52	143/143	53/59	60/60	48/54	145/145
			327A	9.8/13.0	46.9/54.2	70/79	70/80	64/72	143/143	72/82	80/90	66/75	145/145
			329A	13.1/17.4	62.8/72.5	90/102	90/110	82/93	143/143	92/104	100/110	85/96	145/145
			330A	14.4/19.2	69.3/80.0	98/111	100/125	90/102	143/143	100/114	110/125	92/104	145/145
			331A	15.8/21.0	75.8/87.5	106/121	110/125	97/111	143/143	109/123	110/125	99/113	145/145
			326A	7.9/10.5	37.9/43.8	59/66	60/70	54/60	143/143	61/69	70/70	56/63	145/145
	208/230-3-60	STD	NONE	—	—	24	30	24	116	26	30	26	118
			323A	3.3/4.4	9.2/10.6	24/24	30/30	24/24	116/116	26/26	30/30	26/26	118/118
			324A	4.9/6.5	13.6/15.6	24/26	30/30	24/24	116/116	26/29	30/30	26/26	118/118
			325A	6.5/8.7	18.1/20.9	29/33	30/35	27/30	116/116	32/35	35/35	29/32	118/118
			328A	12.0/16.0	33.4/38.5	48/55	50/60	44/50	116/116	51/57	60/60	46/52	118/118
			330A	14.4/19.2	40.0/46.2	57/64	60/70	52/59	116/116	59/67	60/70	54/61	118/118
			331A	15.8/21.0	43.8/50.5	61/70	70/70	56/64	116/116	64/72	70/80	58/66	118/118
			326A	7.9/10.5	21.9/25.3	34/38	35/40	31/35	116/116	36/41	40/45	33/37	118/118
		MED	NONE	—	—	26	30	26	119	28	40	28	121
			323A	3.3/4.4	9.2/10.6	26/26	30/30	26/26	119/119	28/28	40/40	28/28	121/121
			324A	4.9/6.5	13.6/15.6	26/29	30/30	26/26	119/119	29/31	40/40	28/28	121/121
			325A	6.5/8.7	18.1/20.9	32/35	35/35	29/32	119/119	34/38	40/40	31/34	121/121
328A			12.0/16.0	33.4/38.5	51/57	60/60	47/52	119/119	53/60	60/60	49/55	121/121	
330A			14.4/19.2	40.0/46.2	59/67	60/70	54/61	119/119	62/69	70/70	56/63	121/121	
331A			15.8/21.0	43.8/50.5	64/72	70/80	59/66	119/119	66/75	70/80	61/68	121/121	
326A			7.9/10.5	21.9/25.3	37/41	40/45	33/37	119/119	39/43	40/45	36/39	121/121	
HIGH		NONE	—	—	24	30	24	116	26	30	26	118	
		323A	3.3/4.4	9.2/10.6	24/24	30/30	24/24	116/116	26/26	30/30	26/26	118/118	
		324A	4.9/6.5	13.6/15.6	24/26	30/30	24/24	116/116	26/29	30/30	26/26	118/118	
		325A	6.5/8.7	18.1/20.9	29/33	30/35	27/30	116/116	32/35	35/35	29/32	118/118	
		328A	12.0/16.0	33.4/38.5	49/55	50/60	44/50	116/116	51/57	60/60	46/52	118/118	
		330A	14.4/19.2	40.0/46.2	57/65	60/70	52/59	116/116	59/67	60/70	54/61	118/118	
		331A	15.8/21.0	43.8/50.5	62/70	70/70	56/64	116/116	64/72	70/80	58/66	118/118	
		326A	7.9/10.5	21.9/25.3	34/38	35/40	31/35	116/116	37/41	40/45	33/37	118/118	

50GC**05 MCA MOCP Electrical Data (cont)

50GC UNIT SIZE	NOM. V-Ph-Hz	IFM TYPE	ELECTRIC HEATER			NO CONVENIENCE OUTLET OR UNPOWERED CONVENIENCE OUTLET							
			CRHEATER ***A00	NOM (kW)	FLA	No Power Exhaust				With Power Exhaust (powered from unit)			
						MCA	Fuse or HACR BRKR	Disconnect Size		MCA	Fuse or HACR BRKR	Disconnect Size	
FLA	LRA	FLA	LRA										
**05 (cont)	460-3-60	STD	NONE	—	—	12	15	11	66	13	15	12	67
			333A	6.0	7.2	12	15	11	66	13	15	12	67
			335A	11.5	13.8	19	20	17	66	20	25	18	67
			336A	14.0	16.8	23	25	21	66	24	25	22	67
			337A	21.5	25.9	34	35	31	66	36	40	32	67
		MED	NONE	—	—	12	15	12	66	13	15	13	67
			333A	6.0	7.2	12	15	12	66	13	15	13	67
			335A	11.5	13.8	20	20	18	66	21	25	19	67
			336A	14.0	16.8	23	25	21	66	25	25	22	67
		HIGH	337A	21.5	25.9	35	35	32	66	36	40	33	67
			NONE	—	—	13	15	13	67	14	20	14	68
			333A	6.0	7.2	13	15	13	67	14	20	14	68
	335A		11.5	13.8	21	25	19	67	22	25	20	68	
	336A		14.0	16.8	24	25	22	67	26	30	23	68	
	575-3-60	STD	337A	21.5	25.9	36	40	33	67	37	40	34	68
			NONE	—	—	10	15	10	45	12	15	12	47
			339A	10.0	9.6	14	15	12	45	16	20	14	47
		MED	340A	15.0	14.4	20	20	18	45	22	25	20	47
			NONE	—	—	10	15	10	45	12	15	12	47
			339A	10.0	9.6	14	15	13	45	17	20	15	47
HIGH		340A	15.0	14.4	20	20	18	45	23	25	20	47	
		NONE	—	—	11	15	11	46	13	15	13	48	
		339A	10.0	9.6	15	15	13	46	17	20	16	48	
		340A	15.0	14.4	21	25	19	46	23	25	21	48	

50GC**05 MCA MOCOP Electrical Data (cont)

50GC UNIT SIZE	NOM. V-Ph-Hz	IFM TYPE	ELECTRIC HEATER			WITH POWERED CONVENIENCE OUTLET									
			CRHEATER ***A00	NOM (kW)	FLA	No Power Exhaust				With Power Exhaust (powered from unit)					
						MCA	Fuse or HACR BRKR	Disconnect Size		MCA	Fuse or HACR BRKR	Disconnect Size			
								FLA	LRA			FLA	LRA		
**05	208/230-3-60	STD	NONE	—	—	29	40	29	121	31	40	31	123		
			323A	3.3/4.4	9.2/10.6	29/29	40/40	29/29	121/121	31/31	40/40	31/31	123/123		
			324A	4.9/6.5	13.6/15.6	30/32	40/40	29/29	121/121	32/35	40/40	31/31	123/123		
			325A	6.5/8.7	18.1/20.9	35/39	40/40	32/35	121/121	38/41	40/45	34/37	123/123		
			328A	12.0/16.0	33.4/38.5	54/61	60/70	50/56	121/121	57/63	60/70	52/58	123/123		
			330A	14.4/19.2	40.0/46.2	63/70	70/80	57/64	121/121	65/73	70/80	59/67	123/123		
			331A	15.8/21.0	43.8/50.5	67/76	70/80	62/69	121/121	70/78	70/80	64/72	123/123		
		326A	7.9/10.5	21.9/25.3	40/44	40/45	36/40	121/121	42/47	45/50	39/43	123/123			
		MED	NONE	—	—	31	40	32	124	33	45	34	126		
			323A	3.3/4.4	9.2/10.6	31/31	40/40	32/32	124/124	33/33	45/45	34/34	126/126		
			324A	4.9/6.5	13.6/15.6	32/35	40/40	32/32	124/124	35/37	45/45	34/34	126/126		
			325A	6.5/8.7	18.1/20.9	38/41	40/45	35/38	124/124	40/44	45/45	37/40	126/126		
			328A	12.0/16.0	33.4/38.5	57/63	60/70	52/58	124/124	59/66	60/70	54/60	126/126		
			330A	14.4/19.2	40.0/46.2	65/73	70/80	60/67	124/124	68/75	70/80	62/69	126/126		
			331A	15.8/21.0	43.8/50.5	70/78	70/80	64/72	124/124	72/81	80/90	66/74	126/126		
		326A	7.9/10.5	21.9/25.3	43/47	45/50	39/43	124/124	45/49	45/50	41/45	126/126			
		HIGH	NONE	—	—	29	40	29	121	31	40	31	123		
			323A	3.3/4.4	9.2/10.6	29/29	40/40	29/29	121/121	31/31	40/40	31/31	123/123		
			324A	4.9/6.5	13.6/15.6	30/32	40/40	29/29	121/121	32/35	40/40	31/32	123/123		
			325A	6.5/8.7	18.1/20.9	35/39	40/40	32/35	121/121	38/41	40/45	34/38	123/123		
			328A	12.0/16.0	33.4/38.5	55/61	60/70	50/56	121/121	57/63	60/70	52/58	123/123		
			330A	14.4/19.2	40.0/46.2	63/71	70/80	57/65	121/121	65/73	70/80	60/67	123/123		
			331A	15.8/21.0	43.8/50.5	68/76	70/80	62/69	121/121	70/78	70/80	64/72	123/123		
		326A	7.9/10.5	21.9/25.3	40/44	40/45	37/40	121/121	43/47	45/50	39/43	123/123			
		460-3-60	STD	NONE	—	—	14	20	14	68	15	20	15	69	
				333A	6.0	7.2	14	20	14	68	15	20	15	69	
				335A	11.5	13.8	22	25	20	68	23	25	21	69	
				336A	14.0	16.8	26	30	23	68	27	30	24	69	
				337A	21.5	25.9	37	40	34	68	38	40	35	69	
			MED	NONE	—	—	14	20	14	68	15	20	15	69	
				333A	6.0	7.2	14	20	14	68	15	20	15	69	
				335A	11.5	13.8	22	25	20	68	24	25	21	69	
				336A	14.0	16.8	26	30	24	68	27	30	25	69	
				337A	21.5	25.9	37	40	34	68	39	40	35	69	
			HIGH	NONE	—	—	15	20	15	69	16	20	16	70	
				333A	6.0	7.2	15	20	15	69	16	20	16	70	
				335A	11.5	13.8	23	25	21	69	25	25	22	70	
				336A	14.0	16.8	27	30	25	69	28	30	26	70	
				337A	21.5	25.9	39	40	35	69	40	40	36	70	
			575-3-60	STD	NONE	—	—	12	15	12	47	14	15	14	49
					339A	10.0	9.6	16	20	14	47	18	20	16	49
					340A	15.0	14.4	22	25	20	47	24	25	22	49
MED	NONE			—	—	12	15	12	47	14	15	14	49		
	339A			10.0	9.6	16	20	15	47	19	20	17	49		
	340A			15.0	14.4	22	25	20	47	25	25	22	49		
HIGH	NONE	—		—	13	15	13	48	15	20	15	50			
	339A	10.0		9.6	17	20	15	48	20	20	18	50			
	340A	15.0		14.4	23	25	21	48	26	30	23	50			

50GC**05 MCA MOCB Electrical Data with Factory-Installed HACR Breaker

50GC UNIT SIZE	NOM. V-Ph-Hz	IFM TYPE	ELECTRIC HEATER			NO CONVENIENCE OUTLET OR UNPOWERED CONVENIENCE OUTLET									
			CRHEATER ***A00	NOM (kW)	FLA	No Power Exhaust				With Power Exhaust (powered from unit)					
						MCA	HACR BRKR	Disconnect Size		MCA	HACR BRKR	Disconnect Size			
								FLA	LRA			FLA	LRA		
**05	208/230-1-60	STD	NONE	—	—	33	50	32	138	35	50	34	140		
			323A	3.3/4.4	15.9/18.3	33/33	50/50	32/32	138/138	35/35	50/50	34/34	140/140		
			325A	6.5/8.7	31.4/36.3	52/52	60/60	42/47	138/138	54/54	60/60	44/50	140/140		
			327A	9.8/13.0	46.9/54.2	74/74	80/80	60/68	138/138	77/77	80/80	62/70	140/140		
			329A	13.1/17.4	62.8/72.5	97/97	100/100	78/89	138/138	100/100	100/100	80/91	140/140		
			330A	14.4/19.2	69.3/80.0	107/107	110/110	85/98	138/138	109/109	110/110	88/100	140/140		
			331A	15.8/21.0	75.8/87.5	116/116	125/125	93/106	138/138	118/118	125/125	95/109	140/140		
			326A	7.9/10.5	37.9/43.8	61/61	70/70	49/56	138/138	64/64	70/70	52/58	140/140		
		MED	NONE	—	—	35	50	34	141	37	50	36	143		
			323A	3.3/4.4	15.9/18.3	35/35	50/50	34/34	141/141	37/37	50/50	36/36	143/143		
			325A	6.5/8.7	31.4/36.3	55/55	60/60	44/50	141/141	57/57	60/60	46/52	143/143		
			327A	9.8/13.0	46.9/54.2	77/77	80/80	62/70	141/141	79/79	80/80	64/73	143/143		
			329A	13.1/17.4	62.8/72.5	100/100	100/100	80/92	141/141	102/102	110/110	83/94	143/143		
			330A	14.4/19.2	69.3/80.0	109/109	110/110	88/100	141/141	112/112	125/125	90/102	143/143		
			331A	15.8/21.0	75.8/87.5	119/119	125/125	95/109	141/141	121/121	125/125	98/111	143/143		
			326A	7.9/10.5	37.9/43.8	64/64	70/70	52/59	141/141	66/66	70/70	54/61	143/143		
		HIGH	NONE	—	—	37	50	36	143	39	50	38	145		
			323A	3.3/4.4	15.9/18.3	37/37	50/50	36/36	143/143	39/39	50/50	38/38	145/145		
			325A	6.5/8.7	31.4/36.3	57/57	60/60	46/52	143/143	59/59	60/60	48/54	145/145		
			327A	9.8/13.0	46.9/54.2	79/79	80/80	64/72	143/143	82/82	90/90	66/75	145/145		
			329A	13.1/17.4	62.8/72.5	102/102	110/110	82/93	143/143	104/104	110/110	85/96	145/145		
			330A	14.4/19.2	69.3/80.0	111/111	125/125	90/102	143/143	114/114	125/125	92/104	145/145		
			331A	15.8/21.0	75.8/87.5	121/121	125/125	97/111	143/143	123/123	125/125	99/113	145/145		
			326A	7.9/10.5	37.9/43.8	66/66	70/70	54/60	143/143	69/69	70/70	56/63	145/145		
		**05	208/230-3-60	STD	NONE	—	—	24	30	24	116	26	30	26	118
					323A	3.3/4.4	9.2/10.6	24/24	30/30	24/24	116/116	26/26	30/30	26/26	118/118
					324A	4.9/6.5	13.6/15.6	26/26	30/30	24/24	116/116	29/29	30/30	26/26	118/118
					325A	6.5/8.7	18.1/20.9	33/33	35/35	27/30	116/116	35/35	35/35	29/32	118/118
					328A	12.0/16.0	33.4/38.5	55/55	60/60	44/50	116/116	57/57	60/60	46/52	118/118
					330A	14.4/19.2	40.0/46.2	64/64	70/70	52/59	116/116	67/67	70/70	54/61	118/118
					331A	15.8/21.0	43.8/50.5	70/70	70/70	56/64	116/116	72/72	80/80	58/66	118/118
					326A	7.9/10.5	21.9/25.3	38/38	40/40	31/35	116/116	41/41	45/45	33/37	118/118
				MED	NONE	—	—	26	30	26	119	28	40	28	121
					323A	3.3/4.4	9.2/10.6	26/26	30/30	26/26	119/119	28/28	40/40	28/28	121/121
					324A	4.9/6.5	13.6/15.6	29/29	30/30	26/26	119/119	31/31	40/40	28/28	121/121
					325A	6.5/8.7	18.1/20.9	35/35	40/35	29/32	119/119	38/38	40/40	31/34	121/121
328A	12.0/16.0				33.4/38.5	57/57	60/60	47/52	119/119	60/60	60/60	49/55	121/121		
330A	14.4/19.2				40.0/46.2	67/67	70/70	54/61	119/119	69/69	70/70	56/63	121/121		
331A	15.8/21.0				43.8/50.5	72/72	80/80	59/66	119/119	75/75	80/80	61/68	121/121		
326A	7.9/10.5				21.9/25.3	41/41	45/45	33/37	119/119	43/43	45/45	36/39	121/121		
HIGH	NONE			—	—	24	30	24	116	26	30	26	118		
	323A			3.3/4.4	9.2/10.6	24/24	30/30	24/24	116/116	26/26	30/30	26/26	118/118		
	324A			4.9/6.5	13.6/15.6	26/26	30/30	24/24	116/116	29/29	30/30	26/26	118/118		
	325A			6.5/8.7	18.1/20.9	33/33	35/35	27/30	116/116	35/35	35/35	29/32	118/118		
	328A			12.0/16.0	33.4/38.5	55/55	60/60	44/50	116/116	57/57	60/60	46/52	118/118		
	330A			14.4/19.2	40.0/46.2	65/65	70/70	52/59	116/116	67/67	70/70	54/61	118/118		
	331A			15.8/21.0	43.8/50.5	70/70	70/70	56/64	116/116	72/72	80/80	58/66	118/118		
	326A			7.9/10.5	21.9/25.3	38/38	40/40	31/35	116/116	41/41	45/45	33/37	118/118		

Electrical data (cont)



50GC**05 MCA MOCP Electrical Data with Factory-Installed HACR Breaker (cont)

50GC UNIT SIZE	NOM. V-Ph-Hz	IFM TYPE	ELECTRIC HEATER			NO CONVENIENCE OUTLET OR UNPOWERED CONVENIENCE OUTLET							
			CRHEATER ***A00	NOM (kW)	FLA	No Power Exhaust				With Power Exhaust (powered from unit)			
						MCA	HACR BRKR	Disconnect Size		MCA	HACR BRKR	Disconnect Size	
								FLA	LRA			FLA	LRA
**05 (cont)	460-3-60	STD	NONE	—	—	12	15	11	66	13	15	12	67
			333A	6.0	7.2	12	15	11	66	13	15	12	67
			335A	11.5	13.8	19	20	17	66	20	25	18	67
			336A	14.0	16.8	23	25	21	66	24	25	22	67
			337A	21.5	25.9	34	35	31	66	36	40	32	67
		MED	NONE	—	—	12	15	12	66	13	15	13	67
			333A	6.0	7.2	12	15	12	66	13	15	13	67
			335A	11.5	13.8	20	20	18	66	21	25	19	67
			336A	14.0	16.8	23	25	21	66	25	25	22	67
			337A	21.5	25.9	35	35	32	66	36	40	33	67
		HIGH	NONE	—	—	13	15	13	67	14	20	14	68
			333A	6.0	7.2	13	15	13	67	14	20	14	68
	335A		11.5	13.8	21	25	19	67	22	25	20	68	
	336A		14.0	16.8	24	25	22	67	26	30	23	68	
	337A		21.5	25.9	36	40	33	67	37	40	34	68	
	575-3-60	STD	NONE	—	—	10	15	10	45	12	15	12	47
			339A	10.0	9.6	14	15	12	45	16	20	14	47
			340A	15.0	14.4	20	20	18	45	22	25	20	47
		MED	NONE	—	—	10	15	10	45	12	15	12	47
			339A	10.0	9.6	14	15	13	45	17	20	15	47
340A			15.0	14.4	20	20	18	45	23	25	20	47	
HIGH		NONE	—	—	11	15	11	46	13	15	13	48	
		339A	10.0	9.6	15	15	13	46	17	20	16	48	
		340A	15.0	14.4	21	25	19	46	23	25	21	48	

50GC**05 MCA MOCBP Electrical Data with Factory-Installed HACR Breaker (cont)

50GC UNIT SIZE	NOM. V-Ph-Hz	IFM TYPE	ELECTRIC HEATER			WITH POWERED CONVENIENCE OUTLET								
			CRHEATER ***A00	NOM (kW)	FLA	No Power Exhaust				With Power Exhaust (powered from unit)				
						MCA	HACR BRKR	Disconnect Size		MCA	HACR BRKR	Disconnect Size		
								FLA	LRA			FLA	LRA	
**05	208/230-3-60	STD	NONE	—	—	29	40	29	121	31	40	31	123	
			323A	3.3/4.4	9.2/10.6	29/29	40/40	29/29	121/121	31/31	40/40	31/31	123/123	
			324A	4.9/6.5	13.6/15.6	32/32	40/40	29/29	121/121	35/35	40/40	31/31	123/123	
			325A	6.5/8.7	18.1/20.9	39/39	40/40	32/35	121/121	41/41	45/45	34/37	123/123	
			328A	12.0/16.0	33.4/38.5	61/61	70/70	50/56	121/121	63/63	70/70	52/58	123/123	
			330A	14.4/19.2	40.0/46.2	70/70	80/80	57/64	121/121	73/73	80/80	59/67	123/123	
			331A	15.8/21.0	43.8/50.5	76/76	80/80	62/69	121/121	78/78	80/80	64/72	123/123	
		326A	7.9/10.5	21.9/25.3	44/44	45/45	36/40	121/121	47/47	50/50	39/43	123/123		
		MED	NONE	—	—	31	40	32	124	33	45	34	126	
			323A	3.3/4.4	9.2/10.6	31/31	40/40	32/32	124/124	33/33	45/45	34/34	126/126	
			324A	4.9/6.5	13.6/15.6	35/35	40/40	32/32	124/124	37/37	45/45	34/34	126/126	
			325A	6.5/8.7	18.1/20.9	41/41	45/45	35/38	124/124	44/44	45/45	37/40	126/126	
			328A	12.0/16.0	33.4/38.5	63/63	70/70	52/58	124/124	66/66	70/70	54/60	126/126	
			330A	14.4/19.2	40.0/46.2	73/73	80/80	60/67	124/124	75/75	80/80	62/69	126/126	
			331A	15.8/21.0	43.8/50.5	78/78	80/80	64/72	124/124	81/81	90/90	66/74	126/126	
		326A	7.9/10.5	21.9/25.3	47/47	50/50	39/43	124/124	49/49	50/50	41/45	126/126		
		HIGH	NONE	—	—	29	40	29	121	31	40	31	123	
			323A	3.3/4.4	9.2/10.6	29/29	40/40	29/29	121/121	31/31	40/40	31/31	123/123	
			324A	4.9/6.5	13.6/15.6	32/32	40/40	29/29	121/121	35/35	40/40	31/32	123/123	
			325A	6.5/8.7	18.1/20.9	39/39	40/40	32/35	121/121	41/41	45/45	34/38	123/123	
			328A	12.0/16.0	33.4/38.5	61/61	70/70	50/56	121/121	63/63	70/70	52/58	123/123	
			330A	14.4/19.2	40.0/46.2	71/71	80/80	57/65	121/121	73/73	80/80	60/67	123/123	
			331A	15.8/21.0	43.8/50.5	76/76	80/80	62/69	121/121	78/78	80/80	64/72	123/123	
		326A	7.9/10.5	21.9/25.3	44/44	45/45	37/40	121/121	47/47	50/50	39/43	123/123		
	460-3-60	STD	NONE	—	—	14	20	14	68	15	20	15	69	
			333A	6.0	7.2	14	20	14	68	15	20	15	69	
			335A	11.5	13.8	22	25	20	68	23	25	21	69	
			336A	14.0	16.8	26	30	23	68	27	30	24	69	
			337A	21.5	25.9	37	40	34	68	38	40	35	69	
		MED	NONE	—	—	14	20	14	68	15	20	15	69	
			333A	6.0	7.2	14	20	14	68	15	20	15	69	
			335A	11.5	13.8	22	25	20	68	24	25	21	69	
			336A	14.0	16.8	26	30	24	68	27	30	25	69	
			337A	21.5	25.9	37	40	34	68	39	40	35	69	
		HIGH	NONE	—	—	15	20	15	69	16	20	16	70	
			333A	6.0	7.2	15	20	15	69	16	20	16	70	
			335A	11.5	13.8	23	25	21	69	25	25	22	70	
			336A	14.0	16.8	27	30	25	69	28	30	26	70	
			337A	21.5	25.9	39	40	35	69	40	40	36	70	
		575-3-60	STD	NONE	—	—	12	15	12	47	14	15	14	49
				339A	10.0	9.6	16	20	14	47	18	20	16	49
				340A	15.0	14.4	22	25	20	47	24	25	22	49
	MED		NONE	—	—	12	15	12	47	14	15	14	49	
			339A	10.0	9.6	16	20	15	47	19	20	17	49	
			340A	15.0	14.4	22	25	20	47	25	25	22	49	
	HIGH		NONE	—	—	13	15	13	48	15	20	15	50	
			339A	10.0	9.6	17	20	15	48	20	20	18	50	
			340A	15.0	14.4	23	25	21	48	26	30	23	50	

50GC**06 MCA MOCOP Electrical Data

50GC UNIT SIZE	NOM. V-Ph-Hz	IFM TYPE	ELECTRIC HEATER			NO CONVENIENCE OUTLET OR UNPOWERED CONVENIENCE OUTLET							
			CRHEATER ***A00	NOM (kW)	FLA	No Power Exhaust				With Power Exhaust (powered from unit)			
						MCA	Fuse or HACR BRKR	Disconnect Size		MCA	Fuse or HACR BRKR	Disconnect Size	
								FLA	LRA			FLA	LRA
**06	208/230-1-60	STD	NONE	—	—	42	60	41	172	44	60	43	174
			324A	4.9/6.5	23.5/27.1	42/43	60/60	41/41	172/172	44/46	60/60	43/43	174/174
			325A	6.5/8.7	31.4/36.3	49/55	60/60	44/50	172/172	51/57	60/60	47/52	174/174
			327A	9.8/13.0	46.9/54.2	68/77	70/80	62/71	172/172	70/80	80/80	64/73	174/174
			329A	13.1/17.4	62.8/72.5	88/100	90/100	81/92	172/172	90/102	90/110	83/94	174/174
			331A	15.8/21.0	75.8/87.5	104/119	110/125	95/109	172/172	107/121	110/125	98/111	174/174
		MED	NONE	—	—	44	60	42	174	46	60	45	176
			324A	4.9/6.5	23.5/27.1	44/45	60/60	42/42	174/174	46/47	60/60	45/45	176/176
			325A	6.5/8.7	31.4/36.3	50/57	60/60	46/52	174/174	53/59	60/60	48/54	176/176
			327A	9.8/13.0	46.9/54.2	70/79	70/80	64/72	174/174	72/81	80/90	66/74	176/176
			329A	13.1/17.4	62.8/72.5	90/102	90/110	82/93	174/174	92/104	100/110	84/95	176/176
			331A	15.8/21.0	75.8/87.5	106/121	110/125	97/111	174/174	108/123	110/125	99/113	176/176
	208/230-3-60	STD	NONE	—	—	31	45	30	124	33	45	32	126
			324A	4.9/6.5	13.6/15.6	31/31	45/45	30/30	124/124	33/33	45/45	32/32	126/126
			326A	7.9/10.5	21.9/25.3	37/41	45/45	33/37	124/124	39/43	45/45	36/40	126/126
			328A	12.0/16.0	33.4/38.5	51/58	60/60	47/53	124/124	54/60	60/60	49/55	126/126
			331A	15.8/21.0	43.8/50.5	64/73	70/80	59/66	124/124	67/75	70/80	61/69	126/126
			332A	18.4/24.5	51.1/58.9	73/83	80/90	67/76	124/124	76/85	80/90	69/78	126/126
		MED	NONE	—	—	32	45	32	126	34	50	34	128
			324A	4.9/6.5	13.6/15.6	32/32	45/45	32/32	126/126	34/34	50/50	34/34	128/128
			326A	7.9/10.5	21.9/25.3	39/43	45/45	35/39	126/126	41/45	50/50	37/41	128/128
			328A	12.0/16.0	33.4/38.5	53/59	60/60	48/54	126/126	55/62	60/70	50/56	128/128
			331A	15.8/21.0	43.8/50.5	66/74	70/80	60/68	126/126	68/77	70/80	62/70	128/128
			332A	18.4/24.5	51.1/58.9	75/85	80/90	69/78	126/126	77/87	80/90	71/80	128/128
		HIGH	NONE	—	—	30	45	29	123	32	45	31	125
			324A	4.9/6.5	13.6/15.6	30/30	45/45	29/29	123/123	32/32	45/45	31/31	125/125
			326A	7.9/10.5	21.9/25.3	36/40	45/45	33/36	123/123	38/42	45/45	35/39	125/125
			328A	12.0/16.0	33.4/38.5	50/57	60/60	46/52	123/123	53/59	60/60	48/54	125/125
			331A	15.8/21.0	43.8/50.5	63/72	70/80	58/65	123/123	66/74	70/80	60/68	125/125
			332A	18.4/24.5	51.1/58.9	72/82	80/90	66/75	123/123	75/84	80/90	68/77	125/125
	460-3-60	STD	NONE	—	—	12	15	11	59	13	15	12	60
			333A	6.0	7.2	12	15	11	59	13	15	12	60
			335A	11.5	13.8	20	20	18	59	21	25	19	60
			336A	14.0	16.8	23	25	21	59	25	25	22	60
			337A	21.5	25.9	35	35	32	59	36	40	33	60
			338A	24.0	28.9	38	40	35	59	40	40	36	60
		MED	NONE	—	—	12	15	12	60	13	15	13	61
			333A	6.0	7.2	12	15	12	60	13	15	13	61
			335A	11.5	13.8	20	20	18	60	21	25	19	61
			336A	14.0	16.8	24	25	22	60	25	25	23	61
			337A	21.5	25.9	35	35	32	60	36	40	33	61
			338A	24.0	28.9	39	40	35	60	40	40	37	61
		HIGH	NONE	—	—	13	15	13	61	14	20	14	62
			333A	6.0	7.2	13	15	13	61	14	20	14	62
			335A	11.5	13.8	21	25	19	61	23	25	20	62
			336A	14.0	16.8	25	25	23	61	26	30	24	62
			337A	21.5	25.9	36	40	33	61	38	40	34	62
			338A	24.0	28.9	40	40	37	61	41	45	38	62
575-3-60	STD	NONE	—	—	13	15	12	54	14	20	14	56	
		340A	15.0	14.4	20	20	18	54	23	25	20	56	
		341A	21.0	20.2	28	30	25	54	30	30	27	56	
	MED	NONE	—	—	13	15	12	55	15	20	15	57	
		340A	15.0	14.4	21	25	19	55	23	25	21	57	
		341A	21.0	20.2	28	30	25	55	30	30	27	57	
	HIGH	NONE	—	—	14	15	13	56	15	20	15	58	
		340A	15.0	14.4	22	25	19	56	24	25	22	58	
		341A	21.0	20.2	29	30	26	56	31	35	28	58	

50GC**06 MCA MOCOP Electrical Data (cont)

50GC UNIT SIZE	NOM. V-Ph-Hz	IFM TYPE	ELECTRIC HEATER			WITH POWERED CONVENIENCE OUTLET							
			CRHEATER ***A00	NOM (kW)	FLA	No Power Exhaust				With Power Exhaust (powered from unit)			
						MCA	Fuse or HACR BRKR	Disconnect Size		MCA	Fuse or HACR BRKR	Disconnect Size	
								FLA	LRA			FLA	LRA
**06	208/230-3-60	STD	NONE	—	—	36	50	36	129	37	50	38	131
			324A	4.9/6.5	13.6/15.6	36/36	50/50	36/36	129/129	37/37	50/50	38/38	131/131
			326A	7.9/10.5	21.9/25.3	43/47	50/50	39/43	129/129	45/49	50/50	41/45	131/131
			328A	12.0/16.0	33.4/38.5	57/64	60/70	52/58	129/129	60/66	60/70	54/60	131/131
			331A	15.8/21.0	43.8/50.5	70/79	70/80	64/72	129/129	73/81	80/90	66/74	131/131
			332A	18.4/24.5	51.1/58.9	79/89	80/90	73/82	129/129	82/91	90/100	75/84	131/131
		MED	NONE	—	—	37	50	37	131	39	50	39	133
			324A	4.9/6.5	13.6/15.6	37/37	50/50	37/37	131/131	39/39	50/50	39/39	133/133
			326A	7.9/10.5	21.9/25.3	45/49	50/50	41/45	131/131	47/51	50/60	43/47	133/133
			328A	12.0/16.0	33.4/38.5	59/65	60/70	54/60	131/131	61/68	70/70	56/62	133/133
			331A	15.8/21.0	43.8/50.5	72/80	80/80	66/73	131/131	74/83	80/90	68/76	133/133
			332A	18.4/24.5	51.1/58.9	81/91	90/100	74/83	131/131	83/93	90/100	76/85	133/133
		HIGH	NONE	—	—	35	50	35	128	37	50	37	130
			324A	4.9/6.5	13.6/15.6	35/35	50/50	35/35	128/128	37/37	50/50	37/37	130/130
			326A	7.9/10.5	21.9/25.3	42/46	50/50	38/42	128/128	44/48	50/50	40/44	130/130
			328A	12.0/16.0	33.4/38.5	56/63	60/70	51/57	128/128	59/65	60/70	53/59	130/130
			331A	15.8/21.0	43.8/50.5	69/78	70/80	63/71	128/128	72/80	80/80	65/73	130/130
			332A	18.4/24.5	51.1/58.9	78/88	80/90	72/81	128/128	81/90	90/100	74/83	130/130
	460-3-60	STD	NONE	—	—	14	20	14	61	15	20	15	62
			333A	6.0	7.2	14	20	14	61	15	20	15	62
			335A	11.5	13.8	22	25	20	61	24	25	21	62
			336A	14.0	16.8	26	30	24	61	27	30	25	62
			337A	21.5	25.9	37	40	34	61	39	40	35	62
			338A	24.0	28.9	41	45	37	61	42	45	39	62
MED		NONE	—	—	15	20	14	62	16	20	15	63	
		333A	6.0	7.2	15	20	14	62	16	20	15	63	
		335A	11.5	13.8	23	25	21	62	24	25	22	63	
		336A	14.0	16.8	27	30	24	62	28	30	25	63	
		337A	21.5	25.9	38	40	35	62	39	40	36	63	
		338A	24.0	28.9	42	45	38	62	43	45	39	63	
HIGH		NONE	—	—	16	20	15	63	17	20	17	64	
		333A	6.0	7.2	16	20	15	63	17	20	17	64	
		335A	11.5	13.8	24	25	22	63	25	25	23	64	
		336A	14.0	16.8	28	30	25	63	29	30	26	64	
		337A	21.5	25.9	39	40	36	63	40	45	37	64	
		338A	24.0	28.9	43	45	39	63	44	45	40	64	
575-3-60	STD	NONE	—	—	14	20	14	56	16	20	16	58	
		340A	15.0	14.4	22	25	20	56	25	25	22	58	
		341A	21.0	20.2	30	30	27	56	32	35	29	58	
	MED	NONE	—	—	15	20	14	57	16	20	17	59	
		340A	15.0	14.4	23	25	21	57	25	25	23	59	
		341A	21.0	20.2	30	30	27	57	32	35	29	59	
	HIGH	NONE	—	—	15	20	15	58	17	20	17	60	
		340A	15.0	14.4	24	25	21	58	26	30	24	60	
		341A	21.0	20.2	31	35	28	58	33	35	30	60	

50GC**06 MCA MOCP Electrical Data with Factory-Installed HACR Breaker

50GC UNIT SIZE	NOM. V-Ph-Hz	IFM TYPE	ELECTRIC HEATER			NO CONVENIENCE OUTLET OR UNPOWERED CONVENIENCE OUTLET							
			CRHEATER ***A00	NOM (kW)	FLA	No Power Exhaust				With Power Exhaust (powered from unit)			
						MCA	HACR BRKR	Disconnect Size		MCA	HACR BRKR	Disconnect Size	
								FLA	LRA			FLA	LRA
**06	208/230-1-60	STD	NONE	—	—	42	60	41	172	44	60	43	174
			324A	4.9/6.5	23.5/27.1	43/43	60/60	41/41	172/172	46/46	60/60	43/43	174/174
			325A	6.5/8.7	31.4/36.3	55/55	60/60	44/50	172/172	57/57	60/60	47/52	174/174
			327A	9.8/13.0	46.9/54.2	77/77	80/80	62/71	172/172	80/80	80/80	64/73	174/174
			329A	13.1/17.4	62.8/72.5	100/100	100/100	81/92	172/172	102/102	110/110	83/94	174/174
			331A	15.8/21.0	75.8/87.5	119/119	125/125	95/109	172/172	121/121	125/125	98/111	174/174
		MED	NONE	—	—	44	60	42	174	46	60	45	176
			324A	4.9/6.5	23.5/27.1	45/45	60/60	42/42	174/174	47/47	60/60	45/45	176/176
			325A	6.5/8.7	31.4/36.3	57/57	60/60	46/52	174/174	59/59	60/60	48/54	176/176
			327A	9.8/13.0	46.9/54.2	79/79	80/80	64/72	174/174	81/81	90/90	66/74	176/176
			329A	13.1/17.4	62.8/72.5	102/102	110/110	82/93	174/174	104/104	110/110	84/95	176/176
			331A	15.8/21.0	75.8/87.5	121/121	125/125	97/111	174/174	123/123	125/125	99/113	176/176
	208/230-3-60	STD	NONE	—	—	31	45	30	124	33	45	32	126
			324A	4.9/6.5	13.6/15.6	31/31	45/45	30/30	124/124	33/33	45/45	32/32	126/126
			326A	7.9/10.5	21.9/25.3	41/41	45/45	33/37	124/124	43/43	45/45	36/40	126/126
			328A	12.0/16.0	33.4/38.5	58/58	60/60	47/53	124/124	60/60	60/60	49/55	126/126
			331A	15.8/21.0	43.8/50.5	73/73	80/80	59/66	124/124	75/75	80/80	61/69	126/126
			332A	18.4/24.5	51.1/58.9	83/83	90/90	67/76	124/124	85/85	90/90	69/78	126/126
		MED	NONE	—	—	32	45	32	126	34	50	34	128
			324A	4.9/6.5	13.6/15.6	32/32	45/45	32/32	126/126	34/34	50/50	34/34	128/128
			326A	7.9/10.5	21.9/25.3	43/43	45/45	35/39	126/126	45/45	50/50	37/41	128/128
			328A	12.0/16.0	33.4/38.5	59/59	60/60	48/54	126/126	62/62	70/70	50/56	128/128
			331A	15.8/21.0	43.8/50.5	74/74	80/80	60/68	126/126	77/77	80/80	62/70	128/128
			332A	18.4/24.5	51.1/58.9	85/85	90/90	69/78	126/126	87/87	90/90	71/80	128/128
	HIGH	NONE	—	—	30	45	29	123	32	45	31	125	
		324A	4.9/6.5	13.6/15.6	30/30	45/45	29/29	123/123	32/32	45/45	31/31	125/125	
		326A	7.9/10.5	21.9/25.3	40/40	45/45	33/36	123/123	42/42	45/45	35/39	125/125	
		328A	12.0/16.0	33.4/38.5	57/57	60/60	46/52	123/123	59/59	60/60	48/54	125/125	
		331A	15.8/21.0	43.8/50.5	72/72	80/80	58/65	123/123	74/74	80/80	60/68	125/125	
		332A	18.4/24.5	51.1/58.9	82/82	90/90	66/75	123/123	84/84	90/90	68/77	125/125	
	460-3-60	STD	NONE	—	—	12	15	11	59	13	15	12	60
			333A	6.0	7.2	12	15	11	59	13	15	12	60
			335A	11.5	13.8	20	20	18	59	21	25	19	60
			336A	14.0	16.8	23	25	21	59	25	25	22	60
			337A	21.5	25.9	35	35	32	59	36	40	33	60
			338A	24.0	28.9	38	40	35	59	40	40	36	60
		MED	NONE	—	—	12	15	12	60	13	15	13	61
			333A	6.0	7.2	12	15	12	60	13	15	13	61
			335A	11.5	13.8	20	20	18	60	21	25	19	61
			336A	14.0	16.8	24	25	22	60	25	25	23	61
			337A	21.5	25.9	35	35	32	60	36	40	33	61
			338A	24.0	28.9	39	40	35	60	40	40	37	61
	HIGH	NONE	—	—	13	15	13	61	14	20	14	62	
		333A	6.0	7.2	13	15	13	61	14	20	14	62	
		335A	11.5	13.8	21	25	19	61	23	25	20	62	
		336A	14.0	16.8	25	25	23	61	26	30	24	62	
		337A	21.5	25.9	36	40	33	61	38	40	34	62	
		338A	24.0	28.9	40	40	37	61	41	45	38	62	
575-3-60	STD	NONE	—	—	13	15	12	54	14	20	14	56	
		340A	15.0	14.4	20	20	18	54	23	25	20	56	
		341A	21.0	20.2	28	30	25	54	30	30	27	56	
	MED	NONE	—	—	13	15	12	55	15	20	15	57	
		340A	15.0	14.4	21	25	19	55	23	25	21	57	
		341A	21.0	20.2	28	30	25	55	30	30	27	57	
	HIGH	NONE	—	—	14	15	13	56	15	20	15	58	
		340A	15.0	14.4	22	25	19	56	24	25	22	58	
		341A	21.0	20.2	29	30	26	56	31	35	28	58	

50GC**06 MCA MOCP Electrical Data with Factory-Installed HACR Breaker (cont)

50GC UNIT SIZE	NOM. V-Ph-Hz	IFM TYPE	ELECTRIC HEATER			WITH POWERED CONVENIENCE OUTLET							
			CRHEATER ***A00	NOM (KW)	FLA	No Power Exhaust				With Power Exhaust (powered from unit)			
						MCA	HACR BRKR	Disconnect Size		MCA	HACR BRKR	Disconnect Size	
								FLA	LRA			FLA	LRA
**06	208/230-3-60	STD	NONE	—	—	36	50	36	129	37	50	38	131
			324A	4.9/6.5	13.6/15.6	36/36	50/50	36/36	129/129	37/37	50/50	38/38	131/131
			326A	7.9/10.5	21.9/25.3	47/47	50/50	39/43	129/129	49/49	50/50	41/45	131/131
			328A	12.0/16.0	33.4/38.5	64/64	70/70	52/58	129/129	66/66	70/70	54/60	131/131
			331A	15.8/21.0	43.8/50.5	79/79	80/80	64/72	129/129	81/81	90/90	66/74	131/131
			332A	18.4/24.5	51.1/58.9	89/89	90/90	73/82	129/129	91/91	100/100	75/84	131/131
		MED	NONE	—	—	37	50	37	131	39	50	39	133
			324A	4.9/6.5	13.6/15.6	37/37	50/50	37/37	131/131	39/39	50/50	39/39	133/133
			326A	7.9/10.5	21.9/25.3	49/49	50/50	41/45	131/131	51/51	60/60	43/47	133/133
			328A	12.0/16.0	33.4/38.5	65/65	70/70	54/60	131/131	68/68	70/70	56/62	133/133
			331A	15.8/21.0	43.8/50.5	80/80	80/80	66/73	131/131	83/83	90/90	68/76	133/133
			332A	18.4/24.5	51.1/58.9	91/91	100/100	74/83	131/131	93/93	100/100	76/85	133/133
		HIGH	NONE	—	—	35	50	35	128	37	50	37	130
			324A	4.9/6.5	13.6/15.6	35/35	50/50	35/35	128/128	37/37	50/50	37/37	130/130
			326A	7.9/10.5	21.9/25.3	46/46	50/50	38/42	128/128	48/48	50/50	40/44	130/130
			328A	12.0/16.0	33.4/38.5	63/63	70/70	51/57	128/128	65/65	70/70	53/59	130/130
			331A	15.8/21.0	43.8/50.5	78/78	80/80	63/71	128/128	80/80	80/80	65/73	130/130
			332A	18.4/24.5	51.1/58.9	88/88	90/90	72/81	128/128	90/90	100/100	74/83	130/130
	460-3-60	STD	NONE	—	—	14	20	14	61	15	20	15	62
			333A	6.0	7.2	14	20	14	61	15	20	15	62
			335A	11.5	13.8	22	25	20	61	24	25	21	62
			336A	14.0	16.8	26	30	24	61	27	30	25	62
			337A	21.5	25.9	37	40	34	61	39	40	35	62
			338A	24.0	28.9	41	45	37	61	42	45	39	62
		MED	NONE	—	—	15	20	14	62	16	20	15	63
			333A	6.0	7.2	15	20	14	62	16	20	15	63
			335A	11.5	13.8	23	25	21	62	24	25	22	63
			336A	14.0	16.8	27	30	24	62	28	30	25	63
			337A	21.5	25.9	38	40	35	62	39	40	36	63
			338A	24.0	28.9	42	45	38	62	43	45	39	63
		HIGH	NONE	—	—	16	20	15	63	17	20	17	64
			333A	6.0	7.2	16	20	15	63	17	20	17	64
			335A	11.5	13.8	24	25	22	63	25	25	23	64
			336A	14.0	16.8	28	30	25	63	29	30	26	64
			337A	21.5	25.9	39	40	36	63	40	45	37	64
			338A	24.0	28.9	43	45	39	63	44	45	40	64
575-3-60	STD	NONE	—	—	14	20	14	56	16	20	16	58	
		340A	15.0	14.4	22	25	20	56	25	25	22	58	
		341A	21.0	20.2	30	30	27	56	32	35	29	58	
	MED	NONE	—	—	15	20	14	57	16	20	17	59	
		340A	15.0	14.4	23	25	21	57	25	25	23	59	
		341A	21.0	20.2	30	30	27	57	32	35	29	59	
	HIGH	NONE	—	—	15	20	15	58	17	20	17	60	
		340A	15.0	14.4	24	25	21	58	26	30	24	60	
		341A	21.0	20.2	31	35	28	58	33	35	30	60	

50GC**04 Electric Heat Data without Non-Fused Disconnect

50GC UNIT SIZE	NOM. V-Ph-Hz	IFM TYPE	ELECTRIC HEATER PART NUMBER	NOM (kW)	APPLICATION (kW)	APPLICATION OUTPUT (MBtuh)	SINGLE POINT OR JUNCTION PART NUMBER CRSINGLEXXXA00			
							No CO or Unpowered CO		With PWRD CO	
							No PE	With PE (pwrd fr/unit)	No PE	With PE (pwrd fr/unit)
**04	208/230-1-60	STD	CRHEATER323A00	4.4	3.3/4.0	11.3/13.8	—	—	—	—
			CRHEATER324A00	6.5	4.9/6.0	16.7/20.4	—	—	—	—
			CRHEATER325A00	8.7	6.5/8.0	22.3/27.3	—	037	037	037
			CRHEATER326A00	10.5	7.9/9.6	26.9/32.9	037	040	040	040
		CRHEATER327A00	13.0	9.8/11.9	33.3/40.7	040	040	040	040	
		MED	CRHEATER323A00	4.4	3.3/4.0	11.3/13.8	—	—	—	—
			CRHEATER324A00	6.5	4.9/6.0	16.7/20.4	—	—	—	—
			CRHEATER325A00	8.7	6.5/8.0	22.3/27.3	037	037	037	040
			CRHEATER326A00	10.5	7.9/9.6	26.9/32.9	040	040	040	040
		CRHEATER327A00	13.0	9.8/11.9	33.3/40.7	040	040	040	040	
		HIGH	CRHEATER323A00	4.4	3.3/4.0	11.3/13.8	—	—	—	—
			CRHEATER324A00	6.5	4.9/6.0	16.7/20.4	—	—	—	037
	CRHEATER325A00		8.7	6.5/8.0	22.3/27.3	037	037	040	040	
	CRHEATER326A00		10.5	7.9/9.6	26.9/32.9	040	040	040	040	
	CRHEATER327A00	13.0	9.8/11.9	33.3/40.7	040	040	040	040		
	208/230-3-60	STD	CRHEATER323A00	4.4	3.3/4.0	11.3/13.8	—	—	—	—
			CRHEATER324A00	6.5	4.9/6.0	16.7/20.4	—	—	—	—
			CRHEATER325A00	8.7	6.5/8.0	22.3/27.3	—	—	—	—
			CRHEATER326A00	10.5	7.9/9.6	26.9/32.9	—	—	—	—
			CRHEATER328A00	16.0	12.0/14.7	41.0/50.1	037	037	037	038
		MED	CRHEATER323A00	4.4	3.3/4.0	11.3/13.8	—	—	—	—
			CRHEATER324A00	6.5	4.9/6.0	16.7/20.4	—	—	—	—
			CRHEATER325A00	8.7	6.5/8.0	22.3/27.3	—	—	—	—
			CRHEATER326A00	10.5	7.9/9.6	26.9/32.9	—	—	—	—
CRHEATER328A00		16.0	12.0/14.7	41.0/50.1	037	037	038	038		
HIGH		CRHEATER323A00	4.4	3.3/4.0	11.3/13.8	—	—	—	—	
		CRHEATER324A00	6.5	4.9/6.0	16.7/20.4	—	—	—	—	
	CRHEATER325A00	8.7	6.5/8.0	22.3/27.3	—	—	—	—		
	CRHEATER326A00	10.5	7.9/9.6	26.9/32.9	—	—	—	—		
CRHEATER328A00	16.0	12.0/14.7	41.0/50.1	037	037	038	038			
460-3-60	STD	CRHEATER333A00	6.0	5.5	18.8	—	—	—	—	
		CRHEATER334A00	8.8	8.1	27.6	—	—	—	—	
		CRHEATER335A00	11.5	10.6	36.0	—	—	—	—	
		CRHEATER336A00	14.0	12.9	43.9	—	—	—	—	
	MED	CRHEATER333A00	6.0	5.5	18.8	—	—	—	—	
		CRHEATER334A00	8.8	8.1	27.6	—	—	—	—	
		CRHEATER335A00	11.5	10.6	36.0	—	—	—	—	
		CRHEATER336A00	14.0	12.9	43.9	—	—	—	—	
	HIGH	CRHEATER333A00	6.0	5.5	18.8	—	—	—	—	
		CRHEATER334A00	8.8	8.1	27.6	—	—	—	—	
		CRHEATER335A00	11.5	10.6	36.0	—	—	—	—	
		CRHEATER336A00	14.0	12.9	43.9	—	—	—	—	
575-3-60	STD	CRHEATER339A00	10.0	9.2	31.3	—	—	—	—	
		CRHEATER340A00	15.0	13.8	47.0	—	—	—	—	
	MED	CRHEATER339A00	10.0	9.2	31.3	—	—	—	—	
		CRHEATER340A00	15.0	13.8	47.0	—	—	—	—	
	HIGH	CRHEATER339A00	10.0	9.2	31.3	—	—	—	—	
		CRHEATER340A00	15.0	13.8	47.0	—	—	—	—	

50GC**04 Electric Heat Data with Non-Fused Disconnect

50GC UNIT SIZE	NOM. V-Ph-Hz	IFM TYPE	ELECTRIC HEATER PART NUMBER	NOM (kW)	APPLICATION (kW)	APPLICATION OUTPUT (MBtuh)	SINGLE POINT OR JUNCTION PART NUMBER CRSINGLEXXXXA00			
							No CO or Unpowered CO		With PWRD CO	
							No PE	With PE (pwrd fr/unit)	No PE	With PE (pwrd fr/unit)
**04	208/230-1-60	STD	CRHEATER323A00	4.4	3.3/4.0	11.3/13.8	037	037	037	037
			CRHEATER324A00	6.5	4.9/6.0	16.7/20.4	037	037	037	037
			CRHEATER325A00	8.7	6.5/8.0	22.3/27.3	037	037	037	037
			CRHEATER326A00	10.5	7.9/9.6	26.9/32.9	037	040	040	040
			CRHEATER327A00	13.0	9.8/11.9	33.3/40.7	040	040	040	040
		MED	CRHEATER323A00	4.4	3.3/4.0	11.3/13.8	037	037	037	037
			CRHEATER324A00	6.5	4.9/6.0	16.7/20.4	037	037	037	037
			CRHEATER325A00	8.7	6.5/8.0	22.3/27.3	037	037	037	040
			CRHEATER326A00	10.5	7.9/9.6	26.9/32.9	040	040	040	040
			CRHEATER327A00	13.0	9.8/11.9	33.3/40.7	040	040	040	040
		HIGH	CRHEATER323A00	4.4	3.3/4.0	11.3/13.8	037	037	037	037
			CRHEATER324A00	6.5	4.9/6.0	16.7/20.4	037	037	037	037
	CRHEATER325A00		8.7	6.5/8.0	22.3/27.3	037	037	040	040	
	CRHEATER326A00		10.5	7.9/9.6	26.9/32.9	040	040	040	040	
	208/230-3-60	STD	CRHEATER323A00	4.4	3.3/4.0	11.3/13.8	037	037	037	037
			CRHEATER324A00	6.5	4.9/6.0	16.7/20.4	037	037	037	037
			CRHEATER325A00	8.7	6.5/8.0	22.3/27.3	037	037	037	037
			CRHEATER326A00	10.5	7.9/9.6	26.9/32.9	037	037	037	037
			CRHEATER328A00	16.0	12.0/14.7	41.0/50.1	037	037	037	038
		MED	CRHEATER323A00	4.4	3.3/4.0	11.3/13.8	037	037	037	037
			CRHEATER324A00	6.5	4.9/6.0	16.7/20.4	037	037	037	037
			CRHEATER325A00	8.7	6.5/8.0	22.3/27.3	037	037	037	037
			CRHEATER326A00	10.5	7.9/9.6	26.9/32.9	037	037	037	037
			CRHEATER328A00	16.0	12.0/14.7	41.0/50.1	037	037	038	038
HIGH		CRHEATER323A00	4.4	3.3/4.0	11.3/13.8	037	037	037	037	
		CRHEATER324A00	6.5	4.9/6.0	16.7/20.4	037	037	037	037	
	CRHEATER325A00	8.7	6.5/8.0	22.3/27.3	037	037	037	037		
	CRHEATER326A00	10.5	7.9/9.6	26.9/32.9	037	037	037	037		
460-3-60	STD	CRHEATER333A00	6.0	5.5	18.8	—	—	—	—	
		CRHEATER334A00	8.8	8.1	27.6	—	—	—	—	
		CRHEATER335A00	11.5	10.6	36.0	—	—	—	—	
		CRHEATER336A00	14.0	12.9	43.9	—	—	—	—	
	MED	CRHEATER333A00	6.0	5.5	18.8	—	—	—	—	
		CRHEATER334A00	8.8	8.1	27.6	—	—	—	—	
		CRHEATER335A00	11.5	10.6	36.0	—	—	—	—	
		CRHEATER336A00	14.0	12.9	43.9	—	—	—	—	
	HIGH	CRHEATER333A00	6.0	5.5	18.8	—	—	—	—	
		CRHEATER334A00	8.8	8.1	27.6	—	—	—	—	
		CRHEATER335A00	11.5	10.6	36.0	—	—	—	—	
		CRHEATER336A00	14.0	12.9	43.9	—	—	—	—	
575-3-60	STD	CRHEATER339A00	10.0	9.2	31.3	—	—	—	—	
		CRHEATER340A00	15.0	13.8	47.0	—	—	—	—	
	MED	CRHEATER339A00	10.0	9.2	31.3	—	—	—	—	
		CRHEATER340A00	15.0	13.8	47.0	—	—	—	—	
	HIGH	CRHEATER339A00	10.0	9.2	31.3	—	—	—	—	
		CRHEATER340A00	15.0	13.8	47.0	—	—	—	—	

50GC**05 Electric Heat Data without Non-Fused Disconnect

50GC UNIT SIZE	NOM. V-Ph-Hz	IFM TYPE	ELECTRIC HEATER PART NUMBER	NOM (kW)	APPLICATION (kW)	APPLICATION OUTPUT (MBtuh)	SINGLE POINT OR JUNCTION PART NUMBER CRSINGLEXXXXA00			
							No CO or Unpowered CO		With PWRD CO	
							No PE	With PE (pwrd fr/unit)	No PE	With PE (pwrd fr/unit)
**05	208/230-1-60	STD	CRHEATER323A00	4.4	3.3/4.0	11.3/13.8	—	—	—	—
			CRHEATER325A00	8.7	6.5/8.0	22.3/27.3	037	037	037	037
			CRHEATER327A00	13.0	9.8/11.9	33.3/40.7	040	040	040	040
			CRHEATER329A00	17.4	13.1/16.0	44.6/54.5	040	040	040	040
			CRHEATER330A00 ^a	19.2	14.4/17.6	49.2/60.2	040	040	040	040
		CRHEATER331A00 ^b	21.0	15.8/19.3	53.8/65.8	040	040	040	040	
		MED	CRHEATER323A00	4.4	3.3/4.0	11.3/13.8	—	—	—	—
			CRHEATER325A00	8.7	6.5/8.0	22.3/27.3	037	037	040	040
			CRHEATER327A00	13.0	9.8/11.9	33.3/40.7	040	040	040	040
			CRHEATER329A00	17.4	13.1/16.0	44.6/54.5	040	040	040	040
			CRHEATER330A00 ^a	19.2	14.4/17.6	49.2/60.2	040	040	040	040
		CRHEATER331A00 ^b	21.0	15.8/19.3	53.8/65.8	040	040	040	040	
		HIGH	CRHEATER323A00	4.4	3.3/4.0	11.3/13.8	—	—	—	—
			CRHEATER325A00	8.7	6.5/8.0	22.3/27.3	037	037	040	040
			CRHEATER327A00	13.0	9.8/11.9	33.3/40.7	040	040	040	040
	CRHEATER329A00		17.4	13.1/16.0	44.6/54.5	040	040	040	040	
	CRHEATER330A00 ^a		19.2	14.4/17.6	49.2/60.2	040	040	040	040	
	CRHEATER331A00 ^b	21.0	15.8/19.3	53.8/65.8	040	040	040	040		
	208/230-3-60	STD	CRHEATER323A00	4.4	3.3/4.0	11.3/13.8	—	—	—	—
			CRHEATER324A00	6.5	4.9/6.0	16.7/20.4	—	—	—	—
			CRHEATER325A00	8.7	6.5/8.0	22.3/27.3	—	—	—	—
			CRHEATER328A00	16.0	12.0/14.7	41.0/50.1	037	037	038	038
			CRHEATER330A00 ^a	19.2	14.4/17.6	49.2/60.2	038	038	038	038
		CRHEATER331A00 ^b	21.0	15.8/19.3	53.8/65.8	038	038	038	038	
		MED	CRHEATER323A00	4.4	3.3/4.0	11.3/13.8	—	—	—	—
			CRHEATER324A00	6.5	4.9/6.0	16.7/20.4	—	—	—	—
			CRHEATER325A00	8.7	6.5/8.0	22.3/27.3	—	—	—	—
CRHEATER328A00			16.0	12.0/14.7	41.0/50.1	037	037	038	038	
CRHEATER330A00 ^a			19.2	14.4/17.6	49.2/60.2	038	038	038	038	
CRHEATER331A00 ^b		21.0	15.8/19.3	53.8/65.8	038	038	038	038		
HIGH	CRHEATER323A00	4.4	3.3/4.0	11.3/13.8	—	—	—	—		
	CRHEATER324A00	6.5	4.9/6.0	16.7/20.4	—	—	—	—		
	CRHEATER325A00	8.7	6.5/8.0	22.3/27.3	—	—	—	—		
	CRHEATER328A00	16.0	12.0/14.7	41.0/50.1	037	037	038	038		
	CRHEATER330A00 ^a	19.2	14.4/17.6	49.2/60.2	038	038	038	038		
CRHEATER331A00 ^b	21.0	15.8/19.3	53.8/65.8	038	038	038	038			
460-3-60	STD	CRHEATER333A00	6.0	5.5	18.8	—	—	—	—	
		CRHEATER335A00	11.5	10.6	36.0	—	—	—	—	
		CRHEATER336A00	14.0	12.9	43.9	—	—	—	—	
		CRHEATER337A00	21.5	19.7	67.4	037	037	037	037	
	MED	CRHEATER333A00	6.0	5.5	18.8	—	—	—	—	
		CRHEATER335A00	11.5	10.6	36.0	—	—	—	—	
		CRHEATER336A00	14.0	12.9	43.9	—	—	—	—	
		CRHEATER337A00	21.5	19.7	67.4	037	037	037	037	
	HIGH	CRHEATER333A00	6.0	5.5	18.8	—	—	—	—	
		CRHEATER335A00	11.5	10.6	36.0	—	—	—	—	
		CRHEATER336A00	14.0	12.9	43.9	—	—	—	—	
		CRHEATER337A00	21.5	19.7	67.4	037	037	037	037	
575-3-60	STD	CRHEATER339A00	10.0	9.2	31.3	—	—	—	—	
		CRHEATER340A00	15.0	13.8	47.0	—	—	—	—	
	MED	CRHEATER339A00	10.0	9.2	31.3	—	—	—	—	
		CRHEATER340A00	15.0	13.8	47.0	—	—	—	—	
	HIGH	CRHEATER339A00	10.0	9.2	31.3	—	—	—	—	
CRHEATER340A00	15.0	13.8	47.0	—	—	—	—			

NOTE(S):

- a. Do not use with size 05 horizontal duct configuration units.
- b. Do not use with size 05 vertical duct configuration units.

50GC**05 Electric Heat Data with Non-Fused Disconnect

50GC UNIT SIZE	NOM. V-Ph-Hz	IFM TYPE	ELECTRIC HEATER PART NUMBER	NOM (kW)	APPLICATION (kW)	APPLICATION OUTPUT (MBtuh)	SINGLE POINT OR JUNCTION PART NUMBER CRSINGLEXXXXA00			
							No CO or Unpowered CO		With PWRD CO	
							No PE	With PE (pwrd fr/unit)	No PE	With PE (pwrd fr/unit)
**05	208/230-1-60	STD	CRHEATER323A00	4.4	3.3/4.0	11.3/13.8	037	037	037	037
			CRHEATER325A00	8.7	6.5/8.0	22.3/27.3	037	037	037	037
			CRHEATER327A00	13.0	9.8/11.9	33.3/40.7	040	040	040	040
			CRHEATER329A00	17.4	13.1/16.0	44.6/54.5	040	040	040	040
			CRHEATER330A00 ^a	19.2	14.4/17.6	49.2/60.2	040	040	040	040
		CRHEATER331A00 ^b	21.0	15.8/19.3	53.8/65.8	040	040	040	040	
		MED	CRHEATER323A00	4.4	3.3/4.0	11.3/13.8	037	037	037	037
			CRHEATER325A00	8.7	6.5/8.0	22.3/27.3	037	037	040	040
			CRHEATER327A00	13.0	9.8/11.9	33.3/40.7	040	040	040	040
			CRHEATER329A00	17.4	13.1/16.0	44.6/54.5	040	040	040	040
			CRHEATER330A00 ^a	19.2	14.4/17.6	49.2/60.2	040	040	040	040
		HIGH	CRHEATER323A00	4.4	3.3/4.0	11.3/13.8	037	037	037	037
			CRHEATER325A00	8.7	6.5/8.0	22.3/27.3	037	037	040	040
			CRHEATER327A00	13.0	9.8/11.9	33.3/40.7	040	040	040	040
			CRHEATER329A00	17.4	13.1/16.0	44.6/54.5	040	040	040	040
	CRHEATER330A00 ^a		19.2	14.4/17.6	49.2/60.2	040	040	040	040	
	208/230-3-60	STD	CRHEATER323A00	4.4	3.3/4.0	11.3/13.8	037	037	037	037
			CRHEATER324A00	6.5	4.9/6.0	16.7/20.4	037	037	037	037
			CRHEATER325A00	8.7	6.5/8.0	22.3/27.3	037	037	037	037
			CRHEATER328A00	16.0	12.0/14.7	41.0/50.1	037	037	038	038
			CRHEATER330A00 ^a	19.2	14.4/17.6	49.2/60.2	038	038	038	038
		CRHEATER331A00 ^b	21.0	15.8/19.3	53.8/65.8	038	038	038	038	
		MED	CRHEATER323A00	4.4	3.3/4.0	11.3/13.8	037	037	037	037
			CRHEATER324A00	6.5	4.9/6.0	16.7/20.4	037	037	037	037
			CRHEATER325A00	8.7	6.5/8.0	22.3/27.3	037	037	037	037
			CRHEATER328A00	16.0	12.0/14.7	41.0/50.1	037	037	038	038
			CRHEATER330A00 ^a	19.2	14.4/17.6	49.2/60.2	038	038	038	038
HIGH		CRHEATER323A00	4.4	3.3/4.0	11.3/13.8	037	037	037	037	
	CRHEATER324A00	6.5	4.9/6.0	16.7/20.4	037	037	037	037		
	CRHEATER325A00	8.7	6.5/8.0	22.3/27.3	037	037	037	037		
	CRHEATER328A00	16.0	12.0/14.7	41.0/50.1	037	037	038	038		
	CRHEATER330A00 ^a	19.2	14.4/17.6	49.2/60.2	038	038	038	038		
460-3-60	STD	CRHEATER333A00	6.0	5.5	18.8	—	—	—	—	
		CRHEATER335A00	11.5	10.6	36.0	—	—	—	—	
		CRHEATER336A00	14.0	12.9	43.9	—	—	—	—	
		CRHEATER337A00	21.5	19.7	67.4	037	037	037	037	
	MED	CRHEATER333A00	6.0	5.5	18.8	—	—	—	—	
		CRHEATER335A00	11.5	10.6	36.0	—	—	—	—	
		CRHEATER336A00	14.0	12.9	43.9	—	—	—	—	
		CRHEATER337A00	21.5	19.7	67.4	037	037	037	037	
	HIGH	CRHEATER333A00	6.0	5.5	18.8	—	—	—	—	
		CRHEATER335A00	11.5	10.6	36.0	—	—	—	—	
		CRHEATER336A00	14.0	12.9	43.9	—	—	—	—	
		CRHEATER337A00	21.5	19.7	67.4	037	037	037	037	
575-3-60	STD	CRHEATER339A00	10.0	9.2	31.3	—	—	—	—	
		CRHEATER340A00	15.0	13.8	47.0	—	—	—	—	
	MED	CRHEATER339A00	10.0	9.2	31.3	—	—	—	—	
		CRHEATER340A00	15.0	13.8	47.0	—	—	—	—	
	HIGH	CRHEATER339A00	10.0	9.2	31.3	—	—	—	—	
		CRHEATER340A00	15.0	13.8	47.0	—	—	—	—	

NOTE(S):

- a. Do not use with size 05 horizontal duct configuration units.
- b. Do not use with size 05 vertical duct configuration units.

50GC**06 Electric Heat Data without Non-Fused Disconnect

50GC UNIT SIZE	NOM. V-Ph-Hz	IFM TYPE	ELECTRIC HEATER PART NUMBER	NOM (kW)	APPLICATION (kW)	APPLICATION OUTPUT (MBtuh)	SINGLE POINT OR JUNCTION PART NUMBER CRSINGLEXXXA00				
							No CO or Unpowered CO		With PWRD CO		
							No PE	With PE (pwrd fr/unit)	No PE	With PE (pwrd fr/unit)	
**06	208/230-1-60	STD	CRHEATER324A00	6.5	4.9/6.0	16.7/20.4	—	—	—	037	
			CRHEATER325A00	8.7	6.5/8.0	22.3/27.3	037	037	040	040	
			CRHEATER327A00	13.0	9.8/11.9	33.3/40.7	040	040	040	040	
			CRHEATER329A00	17.4	13.1/16.0	44.6/54.5	040	040	040	040	
			CRHEATER331A00	21.0	15.8/19.3	53.8/65.8	040	040	040	040	
		MED	CRHEATER324A00	6.5	4.9/6.0	16.7/20.4	—	—	037	037	
			CRHEATER325A00	8.7	6.5/8.0	22.3/27.3	037	037	040	040	
			CRHEATER327A00	13.0	9.8/11.9	33.3/40.7	040	040	040	040	
			CRHEATER329A00	17.4	13.1/16.0	44.6/54.5	040	040	040	040	
			CRHEATER331A00	21.0	15.8/19.3	53.8/65.8	040	040	040	040	
	208/230-3-60	STD	CRHEATER324A00	6.5	4.9/6.0	16.7/20.4	—	—	—	—	
			CRHEATER326A00	10.5	7.9/9.6	26.9/32.9	—	—	—	—	
			CRHEATER328A00	16.0	12.0/14.7	41.0/50.1	037	037	038	038	
			CRHEATER331A00	21.0	15.8/19.3	53.8/65.8	038	038	038	038	
			CRHEATER332A00	24.5	18.4/22.5	62.8/76.8	038	038	038	038	
		MED	CRHEATER324A00	6.5	4.9/6.0	16.7/20.4	—	—	—	—	
			CRHEATER326A00	10.5	7.9/9.6	26.9/32.9	—	—	—	037	
			CRHEATER328A00	16.0	12.0/14.7	41.0/50.1	037	038	038	038	
			CRHEATER331A00	21.0	15.8/19.3	53.8/65.8	038	038	038	038	
			CRHEATER332A00	24.5	18.4/22.5	62.8/76.8	038	038	038	038	
		HIGH	CRHEATER324A00	6.5	4.9/6.0	16.7/20.4	—	—	—	—	
			CRHEATER326A00	10.5	7.9/9.6	26.9/32.9	—	—	—	—	
			CRHEATER328A00	16.0	12.0/14.7	41.0/50.1	037	037	038	038	
			CRHEATER331A00	21.0	15.8/19.3	53.8/65.8	038	038	038	038	
	460-3-60	STD	CRHEATER333A00	6.0	5.5	18.8	—	—	—	—	
			CRHEATER335A00	11.5	10.6	36.0	—	—	—	—	
			CRHEATER336A00	14.0	12.9	43.9	—	—	—	—	
			CRHEATER337A00	21.5	19.7	67.4	037	037	037	037	
			CRHEATER338A00	24.0	22.0	75.2	037	037	037	037	
		MED	CRHEATER333A00	6.0	5.5	18.8	—	—	—	—	
			CRHEATER335A00	11.5	10.6	36.0	—	—	—	—	
			CRHEATER336A00	14.0	12.9	43.9	—	—	—	—	
			CRHEATER337A00	21.5	19.7	67.4	037	037	037	037	
			CRHEATER338A00	24.0	22.0	75.2	037	037	037	037	
		HIGH	CRHEATER333A00	6.0	5.5	18.8	—	—	—	—	
			CRHEATER335A00	11.5	10.6	36.0	—	—	—	—	
			CRHEATER336A00	14.0	12.9	43.9	—	—	—	—	
			CRHEATER337A00	21.5	19.7	67.4	037	037	037	037	
		575-3-60	STD	CRHEATER340A00	15.0	13.8	47.0	—	—	—	—
				CRHEATER341A00	21.0	19.3	65.8	037	037	037	037
MED	CRHEATER340A00		15.0	13.8	47.0	—	—	—	—		
	CRHEATER341A00		21.0	19.3	65.8	037	037	037	037		
HIGH	CRHEATER340A00		15.0	13.8	47.0	—	—	—	—		
	CRHEATER341A00		21.0	19.3	65.8	037	037	037	037		

50GC**06 Electric Heat Data with Non-Fused Disconnect

50GC UNIT SIZE	NOM. V-Ph-Hz	IFM TYPE	ELECTRIC HEATER PART NUMBER	NOM (kW)	APPLICATION (kW)	APPLICATION OUTPUT (MBtuh)	SINGLE POINT OR JUNCTION PART NUMBER CRSINGLEXXXXA00				
							No CO or Unpowered CO		With PWRD CO		
							No PE	With PE (pwrd fr/unit)	No PE	With PE (pwrd fr/unit)	
**06	208/230-1-60	STD	CRHEATER324A00	6.5	4.9/6.0	16.7/20.4	—	—	—	037	
			CRHEATER325A00	8.7	6.5/8.0	22.3/27.3	037	037	040	040	
			CRHEATER327A00	13.0	9.8/11.9	33.3/40.7	040	040	040	040	
			CRHEATER329A00	17.4	13.1/16.0	44.6/54.5	040	040	040	040	
			CRHEATER331A00	21.0	15.8/19.3	53.8/65.8	040	040	040	040	
		MED	CRHEATER324A00	6.5	4.9/6.0	16.7/20.4	—	—	037	037	
			CRHEATER325A00	8.7	6.5/8.0	22.3/27.3	037	037	040	040	
			CRHEATER327A00	13.0	9.8/11.9	33.3/40.7	040	040	040	040	
			CRHEATER329A00	17.4	13.1/16.0	44.6/54.5	040	040	040	040	
			CRHEATER331A00	21.0	15.8/19.3	53.8/65.8	040	040	040	040	
		208/230-3-60	STD	CRHEATER324A00	6.5	4.9/6.0	16.7/20.4	—	—	—	—
				CRHEATER326A00	10.5	7.9/9.6	26.9/32.9	—	—	—	—
	CRHEATER328A00			16.0	12.0/14.7	41.0/50.1	037	037	038	038	
	CRHEATER331A00			21.0	15.8/19.3	53.8/65.8	038	038	038	038	
	CRHEATER332A00			24.5	18.4/22.5	62.8/76.8	038	038	038	038	
	MED		CRHEATER324A00	6.5	4.9/6.0	16.7/20.4	—	—	—	—	
			CRHEATER326A00	10.5	7.9/9.6	26.9/32.9	—	—	—	037	
			CRHEATER328A00	16.0	12.0/14.7	41.0/50.1	037	038	038	038	
			CRHEATER331A00	21.0	15.8/19.3	53.8/65.8	038	038	038	038	
			CRHEATER332A00	24.5	18.4/22.5	62.8/76.8	038	038	038	038	
	HIGH		CRHEATER324A00	6.5	4.9/6.0	16.7/20.4	—	—	—	—	
			CRHEATER326A00	10.5	7.9/9.6	26.9/32.9	—	—	—	—	
		CRHEATER328A00	16.0	12.0/14.7	41.0/50.1	037	037	038	038		
		CRHEATER331A00	21.0	15.8/19.3	53.8/65.8	038	038	038	038		
		CRHEATER332A00	24.5	18.4/22.5	62.8/76.8	038	038	038	038		
	460-3-60	STD	CRHEATER333A00	6.0	5.5	18.8	—	—	—	—	
			CRHEATER335A00	11.5	10.6	36.0	—	—	—	—	
			CRHEATER336A00	14.0	12.9	43.9	—	—	—	—	
			CRHEATER337A00	21.5	19.7	67.4	037	037	037	037	
			CRHEATER338A00	24.0	22.0	75.2	037	037	037	037	
		MED	CRHEATER333A00	6.0	5.5	18.8	—	—	—	—	
			CRHEATER335A00	11.5	10.6	36.0	—	—	—	—	
			CRHEATER336A00	14.0	12.9	43.9	—	—	—	—	
			CRHEATER337A00	21.5	19.7	67.4	037	037	037	037	
			CRHEATER338A00	24.0	22.0	75.2	037	037	037	037	
		HIGH	CRHEATER333A00	6.0	5.5	18.8	—	—	—	—	
			CRHEATER335A00	11.5	10.6	36.0	—	—	—	—	
	CRHEATER336A00		14.0	12.9	43.9	—	—	—	—		
	CRHEATER337A00		21.5	19.7	67.4	037	037	037	037		
	CRHEATER338A00		24.0	22.0	75.2	037	037	037	037		
575-3-60	STD	CRHEATER340A00	15.0	13.8	47.0	—	—	—	—		
		CRHEATER341A00	21.0	19.3	65.8	037	037	037	037		
	MED	CRHEATER340A00	15.0	13.8	47.0	—	—	—	—		
		CRHEATER341A00	21.0	19.3	65.8	037	037	037	037		
	HIGH	CRHEATER340A00	15.0	13.8	47.0	—	—	—	—		
		CRHEATER341A00	21.0	19.3	65.8	037	037	037	037		

Typical Control Wiring Diagram — 48GC 04-05 208/230-1-60 Unit with Electromechanical Control and POL224 Economizer

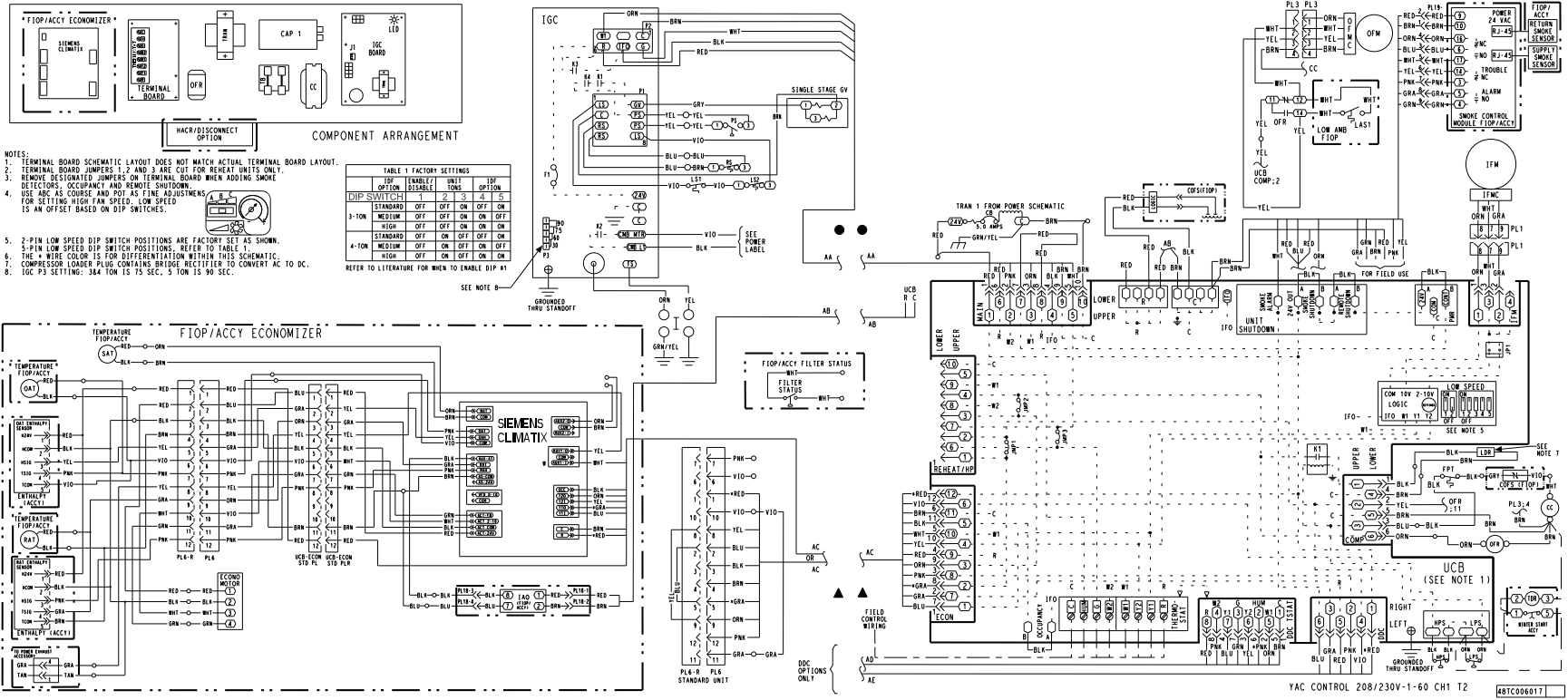

Typical Control Wiring Diagram — 48GC 04-05 208/230-3-60 Unit with Electromechanical Control and POL224 Economizer

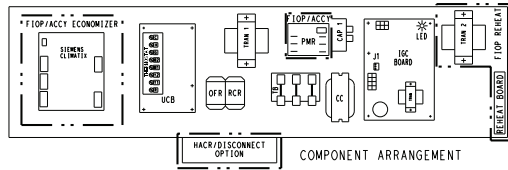

- NOTES:
1. TERMINAL BOARD SCHEMATIC LAYOUT DOES NOT MATCH ACTUAL TERMINAL BOARD LAYOUT.
 2. TERMINAL BOARD JUMPERS 1, 2 AND 3 ARE CUT FOR REHEAT UNITS ONLY.
 3. REMOVE DESIGNATED JUMPERS ON TERMINAL BOARD WHEN ADDING SMOKE DETECTORS, OCCUPANCY AND REMOTE SHUTDOWN.
 4. USE .005 AS COARSE AND .015 AS FINE ADJUSTMENTS FOR SETTING HIGH FAN SPEED. LOW SPEED IS AN OFFSET BASED ON DIP SWITCHES.
 5. 2-PIN LOW SPEED DIP SWITCH POSITIONS ARE FACTORY SET AS SHOWN.
 6. THE * WIRE COLOR IS FOR DIFFERENTIATION WITHIN THIS SCHEMATIC.
 7. COMPRESSOR LOADER PLUS CONTAINS BRIDGE RECTIFIER TO CONVERT AC TO DC.
 8. IGC P3 SETTING: 34 TON IS 75 SEC. 5 TON IS 90 SEC.

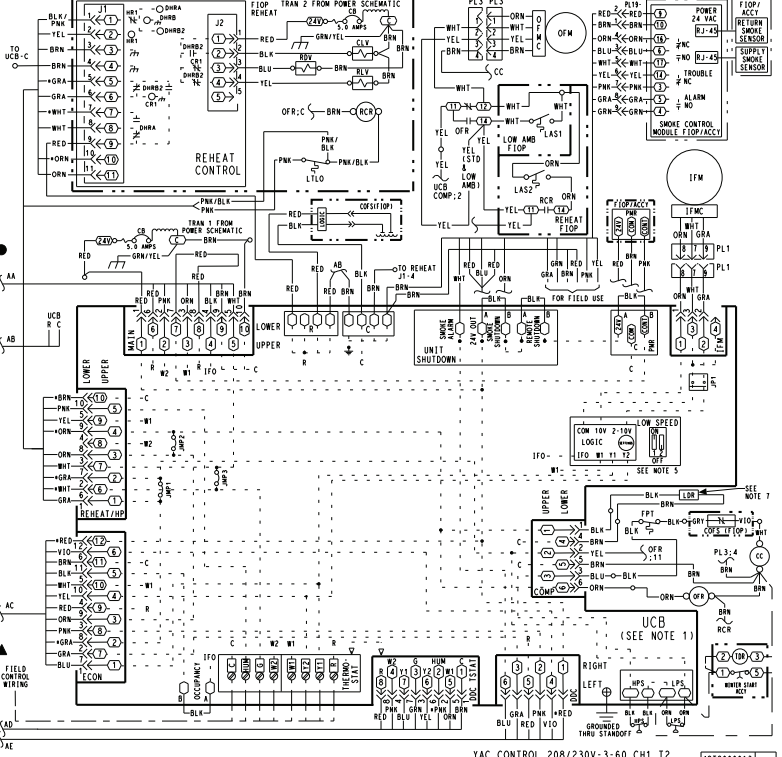
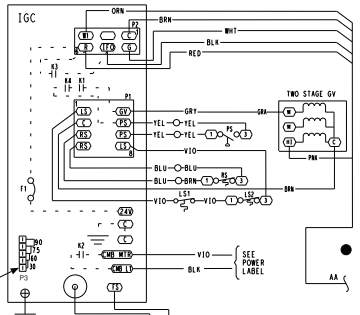
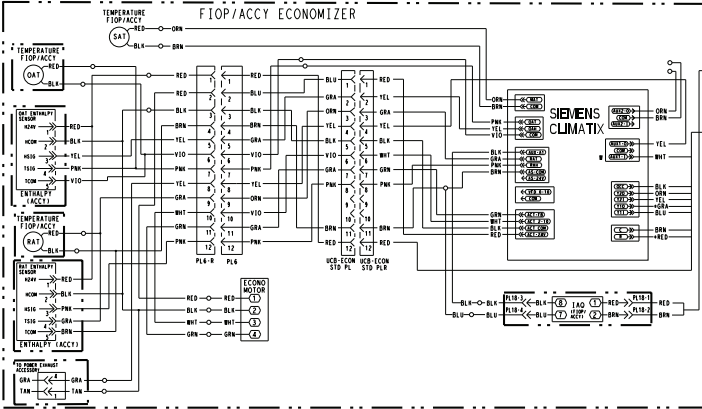

YAC CONTROL 208/230V-3-60 CH1 T2 48TC06013



Typical Control Wiring Diagram — 48GC 04-05 460/575-3-60 Unit with Electromechanical Control and POL224 Economizer

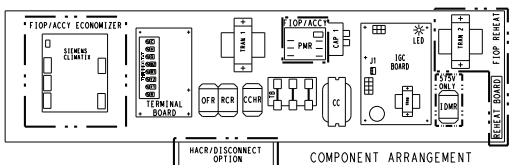

- NOTES:**
1. TERMINAL BOARD SCHEMATIC LAYOUT DOES NOT MATCH ACTUAL TERMINAL BOARD LAYOUT.
 2. TERMINAL BOARD JUMPERS 1, 2 AND 3 ARE CUT FOR REHEAT UNITS ONLY.
 3. REMOVE DESIGNATED JUMPERS ON TERMINAL BOARD WHEN ADDING SMOKE DETECTORS, OCCUPANCY AND REMOTE SHUTDOWN.
 4. USE ABC AS COURSE AND POT AS FINE ADJUSTMENTS FOR SETTING HIGH FAN SPEED. LOW SPEED IS AN OFFSET BASED ON DIP SWITCHES.
 5. 2-PIN LOW SPEED DIP SWITCH POSITIONS ARE FACTORY SET AS SHOWN.
 6. THE * WIRE COLOR IS FOR DIFFERENTIATION WITHIN THIS SCHEMATIC.
 7. COMPRESSOR LEADER PLUG CONTAINS BRIDGE RECTIFIER TO CONVERT AC TO DC.
 8. IGC P3 SETTING: 384 TON IS 75 SEC., 5 TON IS 90 SEC.

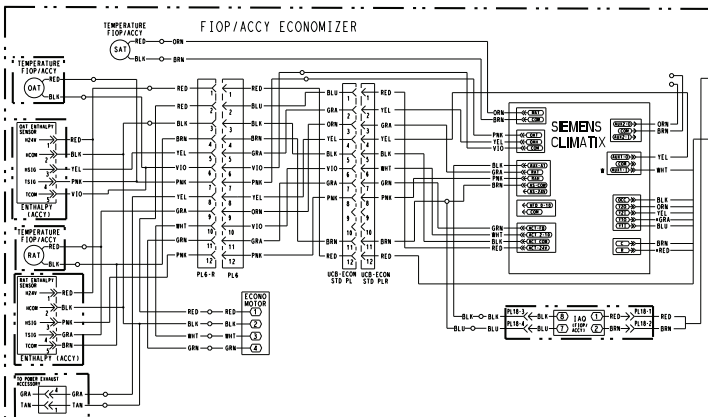
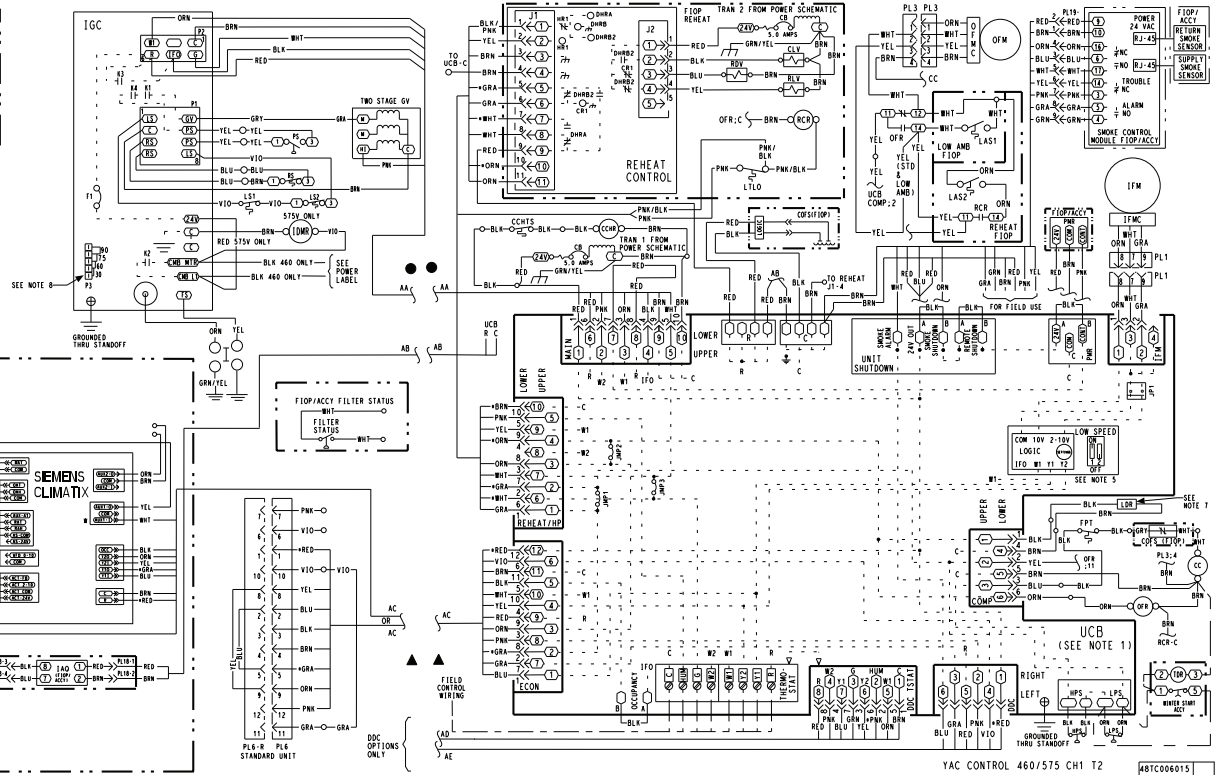

Typical wiring diagrams (cont)



Typical Control Wiring Diagram — 48GC 06 208/230-1-60 Unit with Electromechanical Control and POL224 Economizer

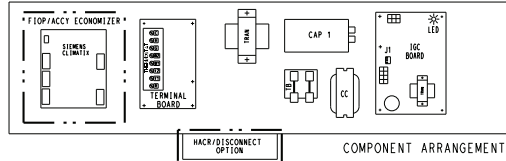

- NOTES:**
- TERMINAL BOARD SCHEMATIC LAYOUT DOES NOT MATCH ACTUAL TERMINAL BOARD LAYOUT.
 - TERMINAL BOARD JUMPERS 1, 2 AND 3 ARE CUT FOR REHEAT UNITS ONLY.
 - REMOVE DESIGNATED JUMPERS ON TERMINAL BOARD WHEN ADDING SMOKE DETECTIONS, OCCUPANCY AND REMOTE SHUTDOWN.
 - USE ABC AS COARSE AND POT AS FINE ADJUSTMENTS FOR SETTING HIGH FAN SPEED. LOW SPEED IS AN OFFSET BASED ON DIP SWITCHES.
 - 2-PIN LOW SPEED DIP SWITCH POSITIONS ARE FACTORY SET AS SHOWN.
 - 5-PIN LOW SPEED DIP SWITCH POSITIONS. REFER TO TABLE 1.
 - THE * WIRE COLOR IS FOR DIFFERENTIATION WITHIN THIS SCHEMATIC.
 - COMPRESSOR LOADER PLUG CONTAINS BRIDGE RECTIFIER TO CONVERT AC TO DC.
 - IGC P3 SETTING: 3/4 TON IS 75 SEC., 5 TON IS 90 SEC.
 - THE ORANGE WIRE EXITING COMP-6 WILL REMAIN UNCONNECTED FOR CORRECT UNIT OPERATION.

TABLE 1 FACTORY SETTINGS

DIP SWITCH	ENABLE	UNIT	OFF	ON
1	STANDARD	OFF	ON	ON
2	STANDARD	OFF	ON	ON
3	STANDARD	OFF	ON	ON
4	STANDARD	OFF	ON	ON
5	STANDARD	OFF	ON	ON
6	STANDARD	OFF	ON	ON
7	STANDARD	OFF	ON	ON
8	STANDARD	OFF	ON	ON
9	STANDARD	OFF	ON	ON
10	STANDARD	OFF	ON	ON
11	STANDARD	OFF	ON	ON
12	STANDARD	OFF	ON	ON

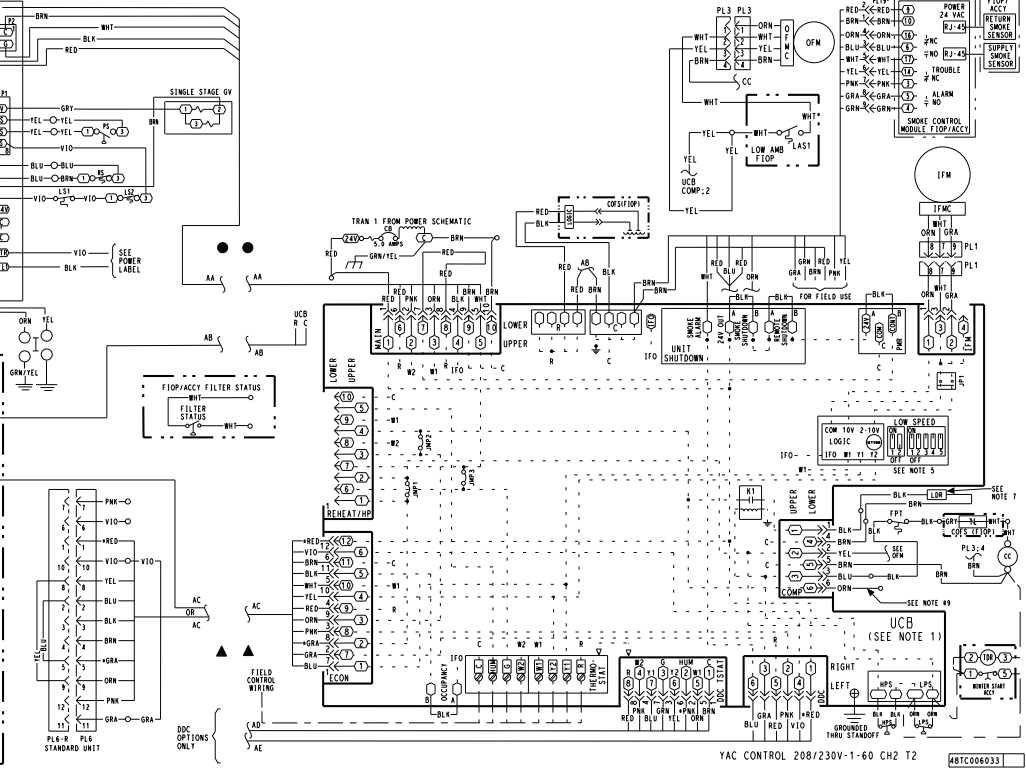
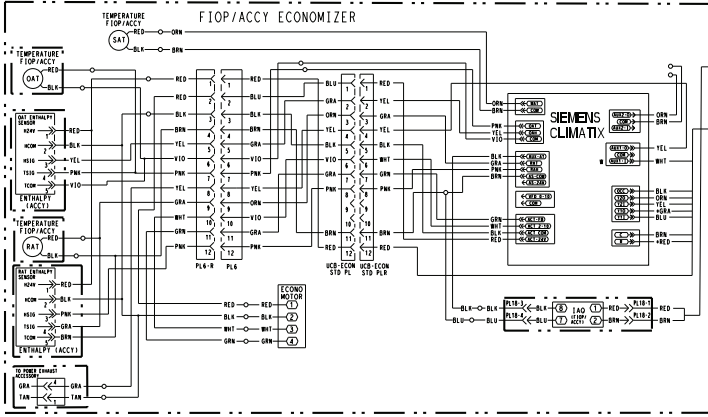

Typical Control Wiring Diagram — 48GC 06 208/230-3-60 Unit with Electromechanical Control and POL224 Economizer

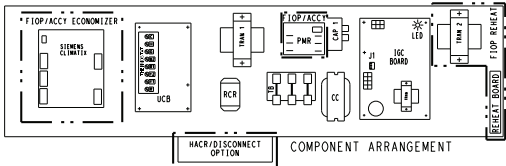

- NOTES:**
1. TERMINAL BOARD SCHEMATIC LAYOUT DOES NOT MATCH ACTUAL TERMINAL BOARD LAYOUT.
 2. TERMINAL BOARD JUMPERS 1, 2 AND 3 ARE CUT FOR REHEAT UNITS ONLY.
 3. REMOVE DESIGNATED JUMPERS ON TERMINAL BOARD WHEN ADDING SMOKE DETECTORS, OCCUPANCY AND REMOTE SHUTDOWN.
 4. USE ACC AS COURSE AND POT AS FINE ADJUSTMENTS FOR SETTING HIGH FAN SPEED. LOW SPEED IS AN OFFSET BASED ON DIP SWITCHES.
 5. 2-PIN LOW SPEED DIP SWITCH POSITIONS ARE FACTORY SET AS SHOWN.
 6. THE * WIRE COLOR IS FOR DIFFERENTIATION WITHIN THIS SCHEMATIC.
 7. COMPRESSOR LOADER PLUG CONTAINS BRIDGE RECTIFIER TO CONVERT AC TO DC.
 8. IGC P3 SETTING: 384 TON IS 75 SEC. 5 TON IS 80 SEC.
 9. THE ORANGE WIRE EXITING COMP-6 WILL REMAIN UNCONNECTED FOR CORRECT UNIT OPERATION.

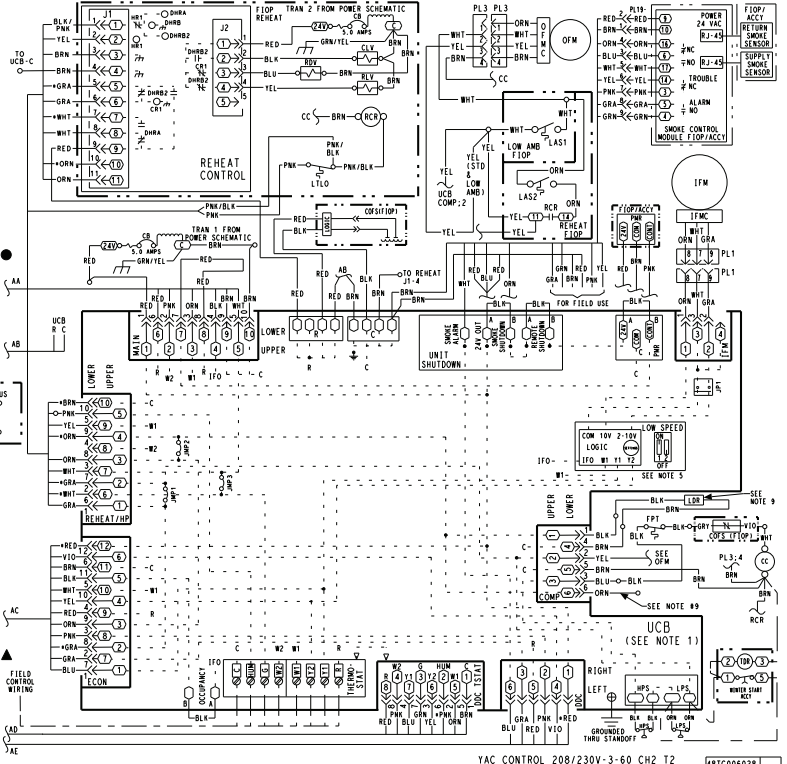
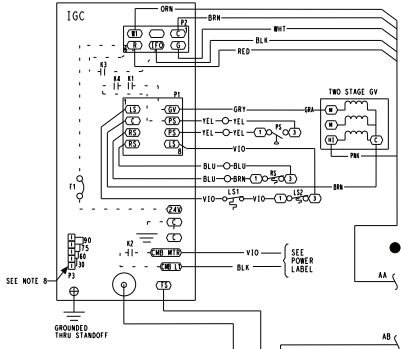
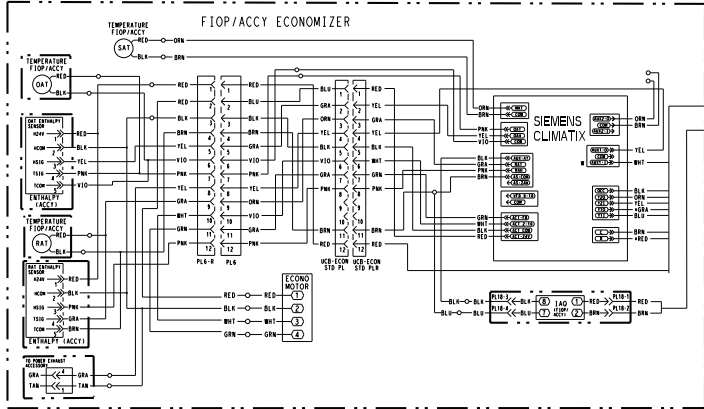

YAC CONTROL 208/230V-3-60 CH2 T2 88TC006028

Typical Control Wiring Diagram — 48GC 06 460/575-3-60 Unit
with Electromechanical Control and POL224 Economizer

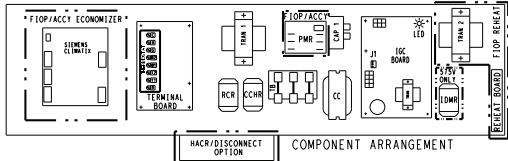

- NOTES:
1. TERMINAL BOARD SCHEMATIC LAYOUT DOES NOT MATCH ACTUAL TERMINAL BOARD LAYOUT.
 2. TERMINAL BOARD JUMPERS 1, 2 AND 3 ARE CUT FOR REHEAT UNITS ONLY.
 3. REMOVE DESIGNATED JUMPERS ON TERMINAL BOARD WHEN ADDING SMOKE DETECTORS, OCCUPANCY AND REMOTE SHUTDOWN.
 4. USE IAC AS COARSE AND POT AS FINE ADJUSTERS FOR SETTING HIGH FAN SPEED. LOW SPEED IS AN OFFSET BASED ON DIP SWITCHES.
 5. 2-PIN LOW SPEED DIP SWITCH POSITIONS ARE FACTORY SET AS SHOWN.
 6. THE WIRE COLOR IS FOR DIFFERENTIATION WITHIN THIS SCHEMATIC.
 7. COMPRESSOR LOADER PLUS CONTAINS BRIDGE RECTIFIER TO CONVERT AC TO DC.
 8. IGC 9-3 SETTING: 38A TON IS 75 SEC., 5 TON IS 90 SEC.
 9. THE ORANGE WIRE EXITING COMP-6 WILL REMAIN UNCONNECTED FOR CORRECT UNIT OPERATION.

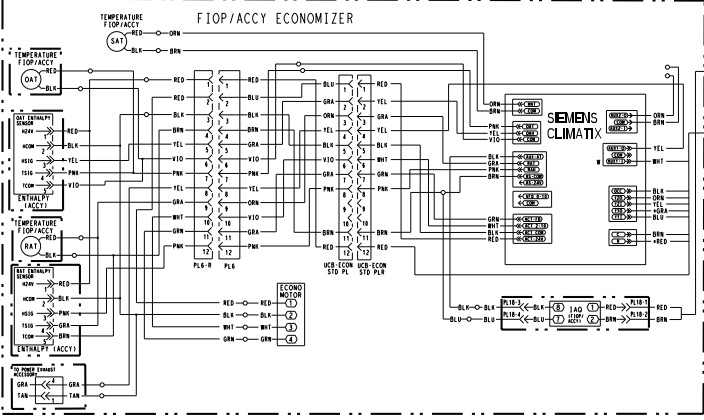
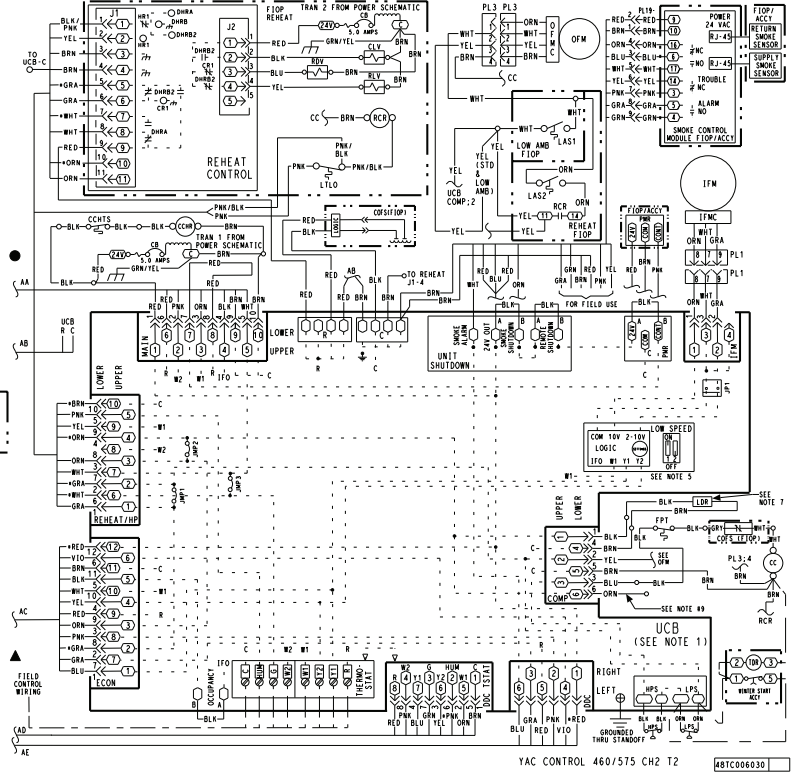
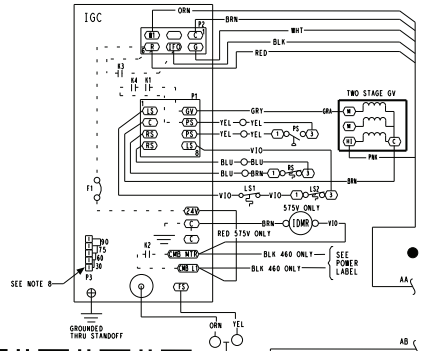

Typical 48GC 04-06 Power Wiring Diagram, 208/230V-3-60 Unit Shown

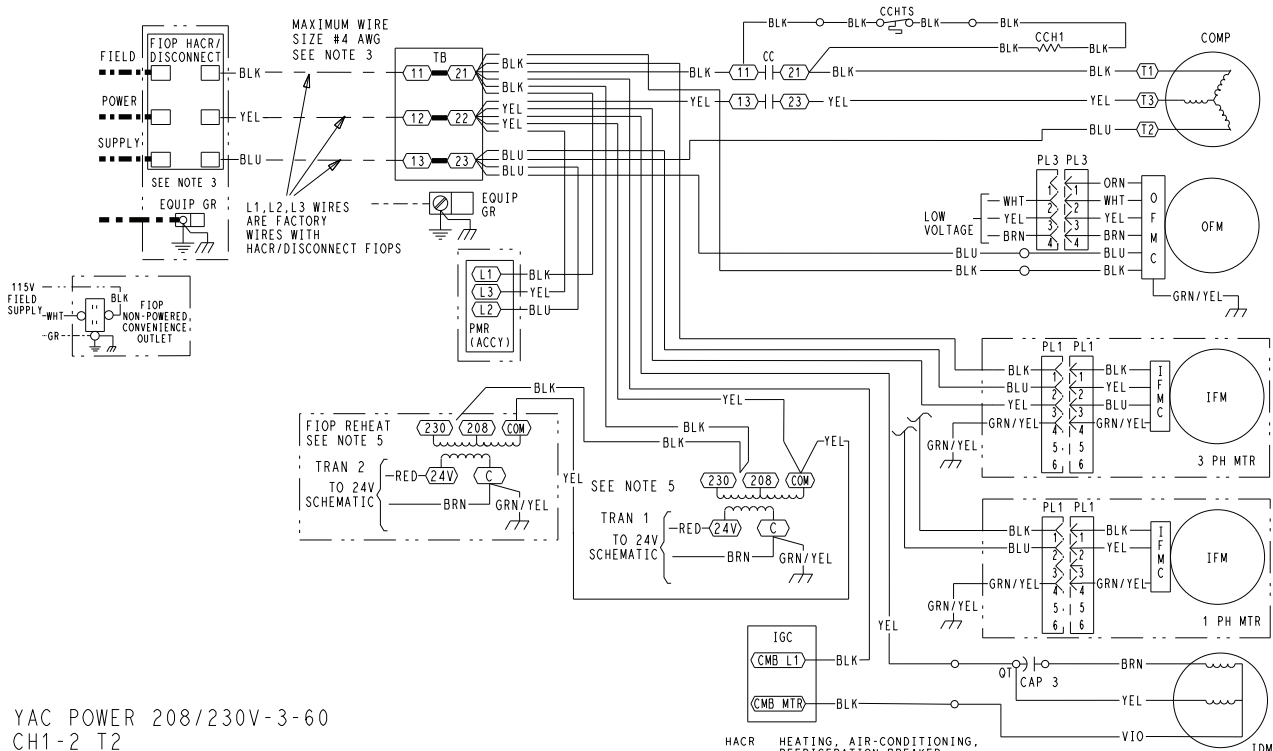

YAC POWER 208/230V-3-60
CH1-2 T2

- NOTES**
- IF ANY OF THE ORIGINAL WIRE FURNISHED MUST BE REPLACED, IT MUST BE REPLACED WITH TYPE 90° C WIRE OR ITS EQUIVALENT.
 - COMPRESSOR AND FAN MOTORS ARE THERMALLY PROTECTED.
 - USE COPPER CONDUCTOR ONLY.
 - DO NOT DISCONNECT POWER PLUG OR SIGNAL WIRE WHILE UNDER LOAD.
 - ON 208/230V UNITS, TRAN IS WIRED FOR 230V. IF UNIT IS TO BE RUN WITH 208V POWER SUPPLY, DISCONNECT BLK WIRE FROM 230V TAP AND CONNECT TO 208V TAP.

- LEGEND**
- (X) MARKED WIRE
 - (X) TERMINAL (MARKED)
 - (O) TERMINAL (UNMARKED)
 - (X) TERMINAL BLOCK
 - SPLICE
 - (●) SPLICE (MARKED)
 - FACTORY WIRING
 - FIELD CONTROL WIRING
 - FIELD POWER WIRING
 - CIRCUIT BOARD TRACE
 - ACCESSORY OR OPTIONAL WIRING

- ACCY ACCESSORY
- AUX AUXILIARY
- AWG AMERICAN WIRE GAGE
- BA BUILDING AUTOMATION NETWORK
- CC CONTACTOR, COMPRESSOR
- C COMMON
- CAP CAPACITOR
- CB CIRCUIT BREAKER
- CCHR CRANKCASE HEATER RELAY
- CLO COMPRESSOR LOCKOUT
- CLV COOLING LIQUID VALVE
- CMB CENTRIFUGAL MOTOR BLOWER
- COFS CONDENSATE OVERFLOW SWITCH
- COM SIGNAL COMMON
- COMP COMPRESSOR MOTOR
- DDC DIRECT DIGITAL CONTROL
- DFB DEFROST BOARD
- DFT DEFROST THERMOSTAT
- EHR ELECTRIC HEAT RELAY
- ENTH ENTHALPY
- EQUIP EQUIPMENT
- ERV ENERGY RECOVERY VENTILATOR
- ESL ENTHALPY SENSOR - LOW
- FB FUSE BLOCK
- FIOF FACTORY INSTALLED OPTION
- FPT FREEZE PROTECTION THERMOSTAT
- FS FLAME SWITCH
- FST FAN HOUSING TEMP SENSOR
- FU FUSE
- FV THERMOSTAT FAN CALL
- G (GRND) GROUND
- GV GAS VALVE

- HACR HEATING, AIR-CONDITIONING, REFRIGERATION BREAKER
- HGRH HOT GAS REHEAT
- HPC HEAD PRESSURE CONTROL
- HPS HIGH PRESSURE SWITCH
- HR HEATER RELAY
- HUM HUMIDISTAT
- I IAQ
- IAQ INDOOR AIR QUALITY SENSORS
- IDM INDUCED DRAFT MOTOR
- IDMR INDUCED DRAFT RELAY
- IFM INDOOR FAN MOTOR
- IFMC INDOOR FAN MOTOR CONTROL
- IFO INDOOR FAN ON SIGNAL
- IGC INTEGRATED GAS CONTROL
- IRH INDOOR RELATIVE HUMIDITY
- JMP JUMPER
- L1 LINE 1
- LA LOW AMBIENT LOCKOUT
- LAR LOW AMBIENT RELAY
- LAS LOW AMBIENT SWITCH
- LDR COMPRESSOR LOADER
- LEN LOCAL EQUIPMENT NETWORK
- LOC LOSS OF CHARGE
- LOOP PWR CURRENT LOOP POWER
- LPS LOW PRESSURE SWITCH
- LS LIMIT SWITCH
- LSM LIMIT SWITCH (MANUAL RESET)
- LTLO LOW TEMP LOCKOUT
- MBB MAIN BASE BOARD
- MOV METAL OXIDE VARISTOR
- MTR MOTOR
- OAO OUTDOOR AIR QUALITY
- OAT OUTDOOR AIR TEMP. SEN
- OFM OUTDOOR FAN MOTOR
- OFMC OUTDOOR FAN MOTOR CONTROL
- OFR OUTDOOR FAN RELAY
- OL OVERLOAD
- PER POWER EXHAUST RELAY
- PH PHASE
- PL PLUG ASSEMBLY
- POT POTENTIOMETER
- PMR PHASE MONITOR RELAY
- PS PRESSURE SWITCH
- PWM PULSE WIDTH MODULATION
- QT QUADRUPLE TERMINAL
- R THERMOSTAT POWER
- RAT RETURN AIR TEMP. SEN
- RCR REHEAT CONTROL RELAY
- RDV REHEAT DISCHARGE VALVE
- RH RELATIVE HUMIDITY
- RLV REHEAT LIQUID VALVE
- RNE LOCAL ACCESS NETWORK
- RS ROLL-OUT SWITCH
- RVS REVERSING VALVE SOLENOID
- SAT SUPPLY AIR TEMP SENSOR
- SDP SYSTEM DISCHARGE PRESSURE
- SRRH SPACE RELATIVE HUMIDITY
- SPT SPACE TEMPERATURE SENSOR
- SPTO SPACE TEMPERATURE OFFSET
- SSP SYSTEM SUCTION PRESSURE
- STD STANDARD
- SW SWITCH
- TB TERMINAL BLOCK
- TDR TIME DELAY RELAY
- TRAN TRANSFORMER
- UCB UNIT CONTROL BOARD
- W1 1st STAGE OF HEATING CALL
- W2 2nd STAGE OF HEATING CALL
- Y1 1st STAGE OF COOLING CALL
- Y2 2nd STAGE OF COOLING CALL

48TC00573 B

Typical 48GC 04-06 Power Wiring Diagram, 460/575V-3-60 Unit Shown

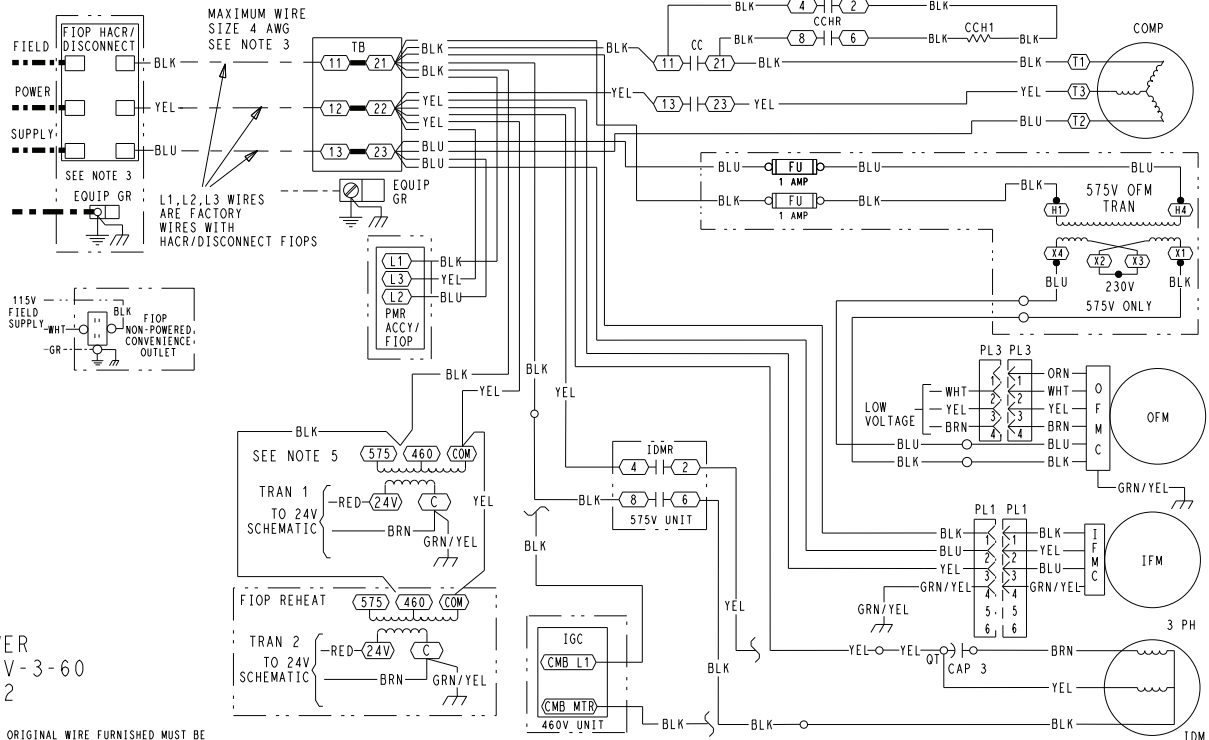

YAC POWER
460/575V-3-60
CH1-2 T2

- NOTES**
1. IF ANY OF THE ORIGINAL WIRE FURNISHED MUST BE REPLACED, IT MUST BE REPLACED WITH TYPE 90° C WIRE OR ITS EQUIVALENT.
 2. COMPRESSOR AND FAN MOTORS ARE THERMALLY PROTECTED.
 3. USE COPPER CONDUCTOR ONLY.
 4. DO NOT DISCONNECT POWER PLUG OR SIGNAL WIRE WHILE UNDER LOAD.
 5. TRANSFORMER IS DEDICATED BASED ON UNIT VOLTAGE. TAPS ONLY SHOWN TO SIMPLIFY SCHEMATIC.

LEGEND

- (X) MARKED WIRE
- (X) TERMINAL (MARKED)
- () TERMINAL (UNMARKED)
- (X) TERMINAL BLOCK
- SPLICE
- SPLICE (MARKED)
- — — — — FACTORY WIRING
- — — — — FIELD CONTROL WIRING
- — — — — FIELD POWER WIRING
- — — — — CIRCUIT BOARD TRACE
- — — — — ACCESSORY OR OPTIONAL WIRING

- | | | | | | |
|---------|--|----------|-----------------------------|------|---------------------------|
| ACCY | ACCESSORY | HGRH | HOT GAS REHEAT | OL | OVERLOAD |
| AUX | AUXILIARY | HPC | HEAD PRESSURE CONTROL | PER | POWER EXHAUST RELAY |
| AWG | AMERICAN WIRE GAGE | HPS | HIGH PRESSURE SWITCH | PH | PHASE |
| BA | BUILDING AUTOMATION NETWORK | HR | HEATER RELAY | PL | PLUG ASSEMBLY |
| CC | CONTACTOR, COMPRESSOR | HUM | HUMIDISTAT | POT | POTENTIOMETER |
| CC | COMMON | IAQ | INDOOR AIR QUALITY SENSORS | PMR | PHASE MONITOR RELAY |
| CAP | CAPACITOR | IDM | INDUCED DRAFT MOTOR | PS | PRESSURE SWITCH |
| CB | CIRCUIT BREAKER | IDMR | INDUCED DRAFT RELAY | PWM | PULSE WIDTH MODULATION |
| CCH | CRANKCASE HEATER | IFM | INDOOR FAN MOTOR | QT | QUADRUPLE TERMINAL |
| CCHR | CRANKCASE HEATER RELAY | IFMC | INDOOR FAN MOTOR CONTROL | R | THERMOSTAT POWER |
| CCHTS | CRANKCASE HEATER TEMP SWITCH | IFO | INDOOR FAN ON SIGNAL | RAT | RETURN AIR TEMP. SEN |
| CLO | COMPRESSOR LOCKOUT | IGC | INTEGRATED GAS CONTROL | RCR | REHEAT CONTROL RELAY |
| CLV | COOLING LIQUID VALVE | I | IGNITOR | RDV | REHEAT DISCHARGE VALVE |
| CMB | CENTRIFUGAL MOTOR BLOWER | IRH | INDOOR RELATIVE HUMIDITY | RH | RELATIVE HUMIDITY |
| COFS | CONDENSATE OVERFLOW SWITCH | JMP | JUMPER | RLV | REHEAT LIQUID VALVE |
| COM | SIGNAL COMMON | L1 | LINE 1 | RNET | LOCAL ACCESS NETWORK |
| COMP | COMPRESSOR MOTOR | LA | LOW AMBIENT LOCKOUT | RS | ROLLOUT SWITCH |
| DDC | DIRECT DIGITAL CONTROL | LAR | LOW AMBIENT RELAY | RVS | REVERSING VALVE SOLENOID |
| DFB | DEFROST BOARD | LAS | LOW AMBIENT SWITCH | SAT | SUPPLY AIR TEMP. SENSOR |
| DFT | DEFROST THERMOSTAT | LDR | COMPRESSOR LOADER | SDP | SYSTEM DISCHARGE PRESSURE |
| EHR | ELECTRIC HEAT RELAY | LEN | LOCAL EQUIPMENT NETWORK | SPRH | SPACE RELATIVE HUMIDITY |
| ENTH | ENTHALPY | LOP | LOSS OF CHARGE | SPT | SPACE TEMPERATURE SENSOR |
| EQUIP | EQUIPMENT | LOOP PWR | CURRENT LOOP POWER | SPTO | SPACE TEMPERATURE OFFSET |
| ERV | ENERGY RECOVERY VENTILATOR | LPS | LOW PRESSURE SWITCH | SSP | SYSTEM SUCTION PRESSURE |
| ESL | ENTHALPY SENSOR - LOW | LS | LIMIT SWITCH | STD | STANDARD |
| FB | FUSE BLOCK | LSW | LIMIT SWITCH (MANUAL RESET) | SW | SWITCH |
| FIOP | FACTORY INSTALLED OPTION | LTL | LOW TEMP LOCKOUT | TB | TERMINAL BLOCK |
| FPT | FREEZE PROTECTION THERMOSTAT | LTILO | LOW TEMP LOCKOUT | TDR | TIME DELAY RELAY |
| FS | FLAME SWITCH | MBB | MAIN BASE BOARD | TRAN | TRANSFORMER |
| FST | FAN HOUSING TEMP SENSOR | MOV | METAL OXIDE VARISTOR | UCB | UNIT CONTROL BOARD |
| FU | FUSE | MTR | MOTOR | W1 | 1st STAGE OF HEATING CALL |
| G | THERMOSTAT FAN CALL | OAO | OUTDOOR AIR QUALITY | W2 | 2nd STAGE OF HEATING CALL |
| GR(GND) | GROUND | OAT | OUTDOOR AIR TEMP. SEN | Y1 | 1st STAGE OF COOLING CALL |
| GV | GAS VALVE | OFM | OUTDOOR FAN MOTOR | Y2 | 2nd STAGE OF COOLING CALL |
| HACR | HEATING, AIR-CONDITIONING, REFRIGERATION BREAKER | OFMC | OUTDOOR FAN MOTOR CONTROL | | |
| HGRH | HOT GAS REHEAT | OR | OUTDOOR FAN RELAY | | |

48TC005575 A

Typical Control Wiring Diagram — 50GC 04-05 208/230-1-60 Unit with Electromechanical Control and POL224 Economizer

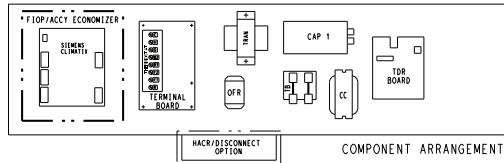

- NOTES:
1. TERMINAL BOARD SCHEMATIC LAYOUT DOES NOT MATCH ACTUAL TERMINAL BOARD LAYOUT.
 2. TERMINAL BOARD JUMPERS 1, 2 AND 3 ARE CUT FOR REHEAT UNITS ONLY.
 3. REMOVE DESIGNATED JUMPERS ON TERMINAL BOARD WHEN ADDING SMOKE DETECTORS, OCCUPANCY AND REMOTE SHUTDOWN.
 4. USE ABC AS COURSE AND POT AS FINE ADJUSTMENTS FOR SETTING HIGH FAN SPEED. LOW SPEED IS AN OFFSET BASED ON DIP SWITCHES.
 5. 2-PIN LOW SPEED DIP SWITCH POSITIONS ARE FACTORY SET AS SHOWN.
 6. THE * WIRE COLOR IS FOR DIFFERENTIATION WITHIN THIS SCHEMATIC.
 7. COMPRESSOR LOADER PLUG CONTAINS BRIDGE RECTIFIER TO CONVERT AC TO DC.
 8. TB4 LOCATED IN HEAT SECTION.
 9. TO CONVERT TO A SINGLE STAGE HEATER MOVE VIOLET WIRE AT TB4 TO CONNECT WITH WHITE WIRE.

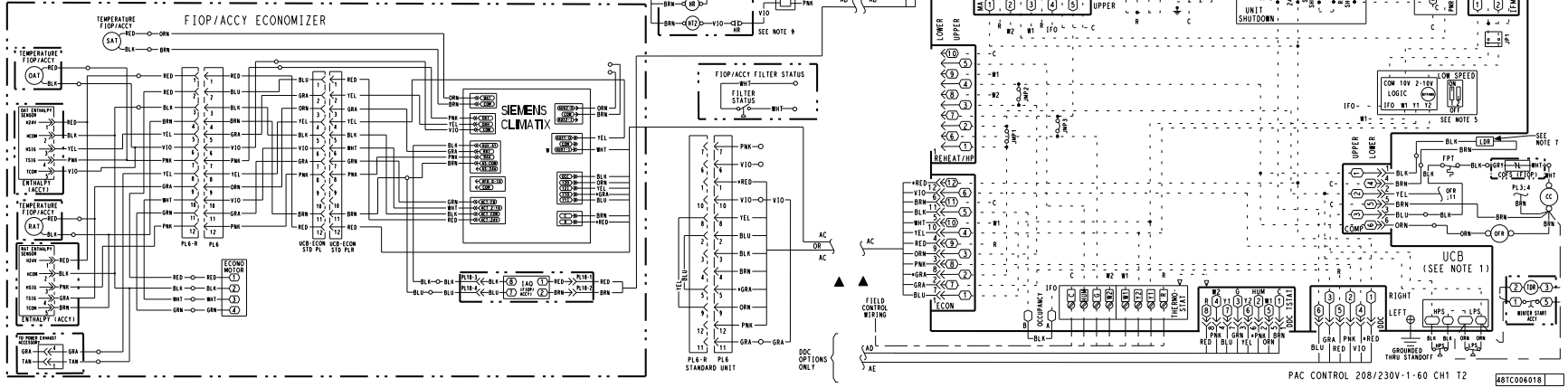

Typical Control Wiring Diagram — 50GC 04-05 208/230-3-60 Unit with Electromechanical Control and POL224 Economizer

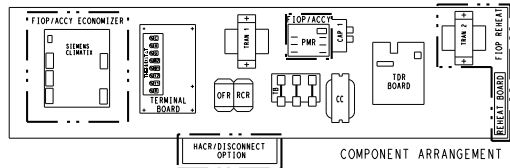

- NOTES:
1. TERMINAL BOARD SCHEMATIC LAYOUT DOES NOT MATCH ACTUAL TERMINAL BOARD LAYOUT.
 2. TERMINAL BOARD JUMPERS 1, 2 AND 3 ARE CUT FOR REHEAT UNITS ONLY.
 3. REMOVE DESIGNATED JUMPERS ON TERMINAL BOARD WHEN ADDING SMOKE DETECTORS, OCCUPANCY AND REMOTE SHUTDOWN.
 4. USE ABC AS COURSE AND AS POT FINE ADJUSTMENTS FOR SETTING HIGH FAN SPEED. LOW SPEED IS AN OFFSET BASED ON DIP SWITCHES.
 5. 2-PIN LOW SPEED DIP SWITCH POSITIONS ARE FACTORY SET AS SHOWN.
 6. THE + WIRE COLOR IS FOR DIFFERENTIATION WITHIN THIS SCHEMATIC.
 7. COMPRESSOR LEADER PLUG CONTAINS BRIDGE RECTIFIER TO CONVERT AC TO DC.
 8. T84 LOCATED IN HEAT SECTION.
 9. TO CONVERT TO A SINGLE STAGE HEATER MOVE VIOLET WIRE AT T84 TO CONNECT WITH WHITE WIRE.

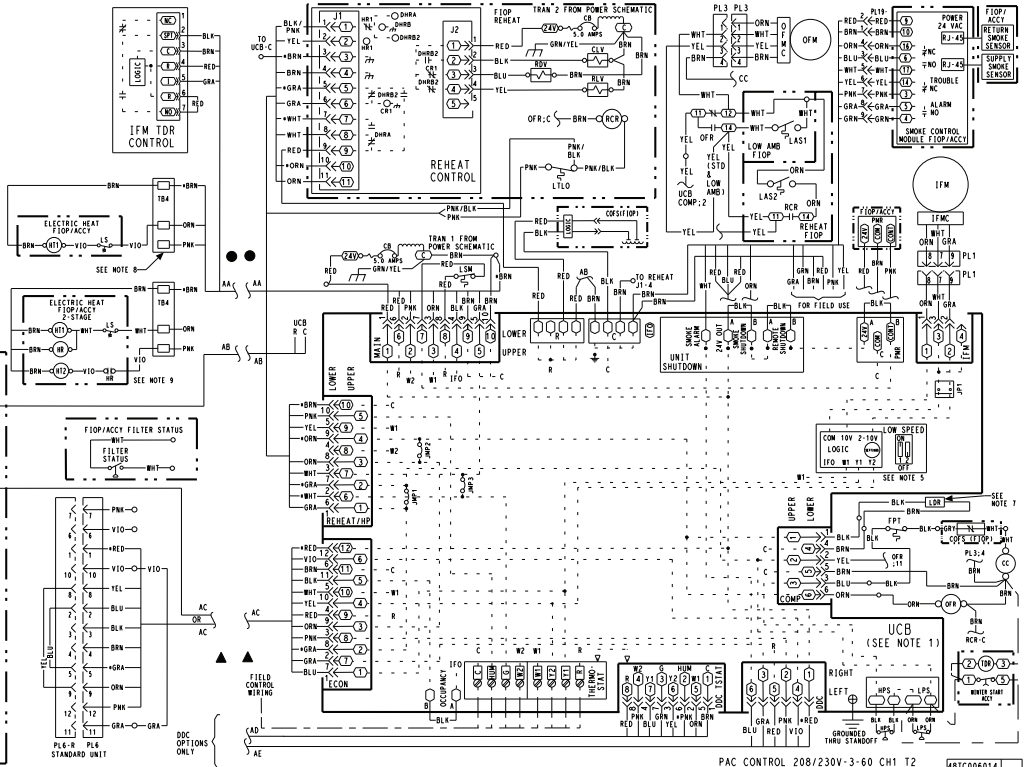
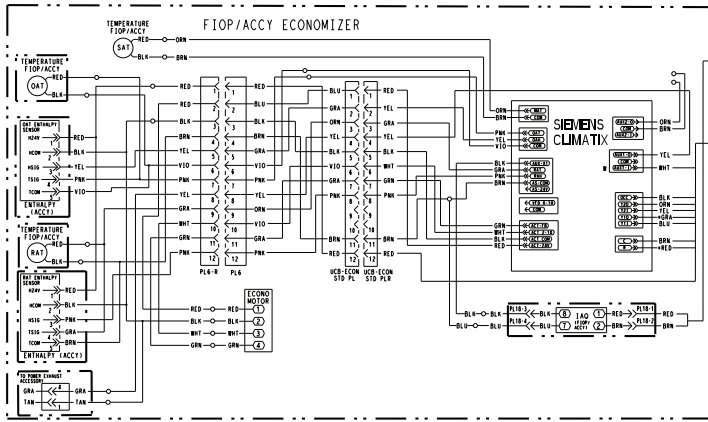

Typical Control Wiring Diagram — 50GC 04-05 460/575-3-60 Unit with Electromechanical Control and POL224 Economizer

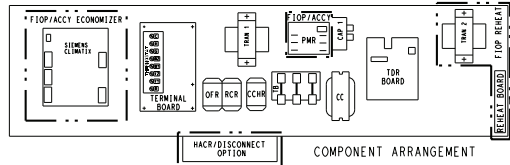

- NOTES:**
1. TERMINAL BOARD SCHEMATIC LAYOUT DOES NOT MATCH ACTUAL TERMINAL BOARD LAYOUT.
 2. TERMINAL BOARD JUMPERS 1, 2 AND 3 ARE CUT FOR REHEAT UNITS ONLY.
 3. REMOVE DESIGNATED JUMPERS ON TERMINAL BOARD WHEN ADDING SMOKE DETECTORS, OCCUPANCY AND REMOTE SHUTDOWN.
 4. USE ABC AS COURSE AND ROT AS FINE ADJUSTMENTS FOR SETTING HIGH FAN SPEED. LOW SPEED IS AN OFFSET BASED ON DIP SWITCHES.
 5. 2-PIN LOW SPEED DIP SWITCH POSITIONS ARE FACTORY SET AS SHOWN.
 6. THE * WIRE COLOR IS FOR DIFFERENTIATION WITHIN THIS SCHEMATIC.
 7. COMPRESSOR LOADER PLUG CONTAINS BRIDGE RECTIFIER TO CONVERT AC TO DC.
 8. TB4 LOCATED IN HEAT SECTION.
 9. TO CONVERT TO A SINGLE STAGE HEATER MOVE VIOLE WIRE AT TB4 TO CONNECT WITH WHITE WIRE.

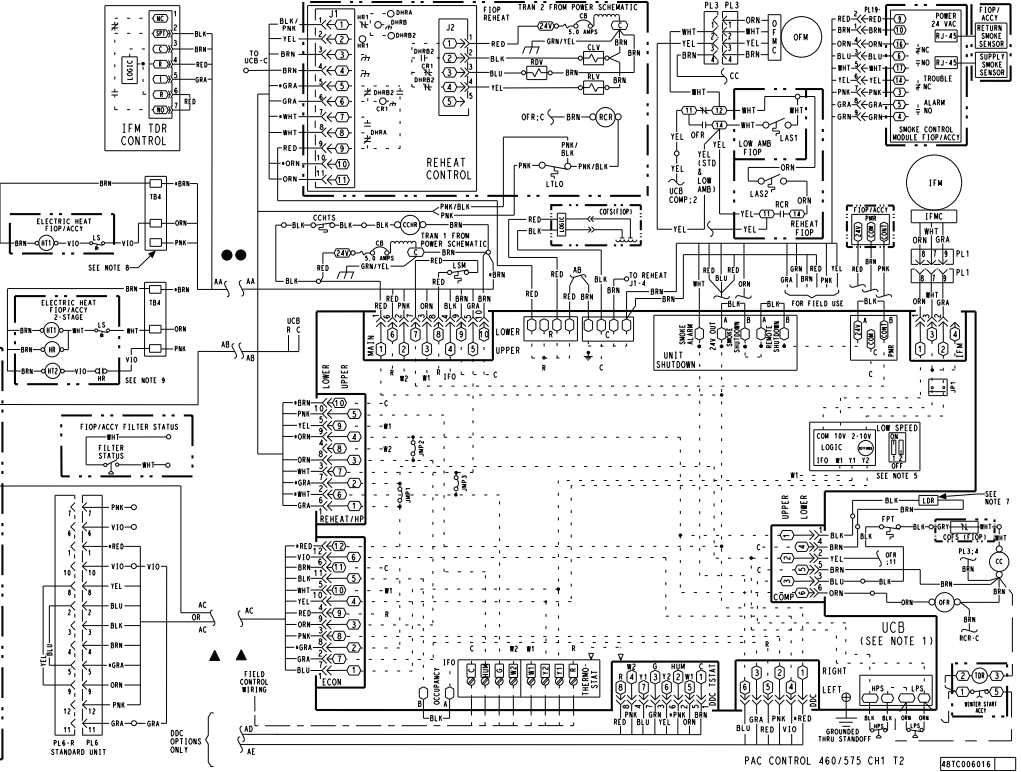
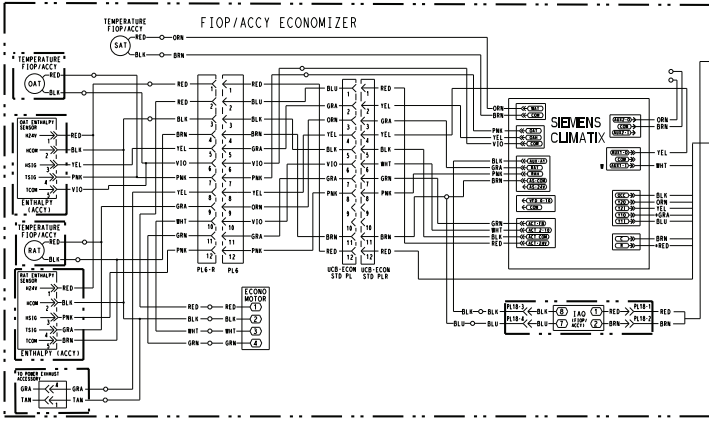

Typical Control Wiring Diagram — 50GC 06 208/230-3-60 Unit with Electromechanical Control and POL224 Economizer

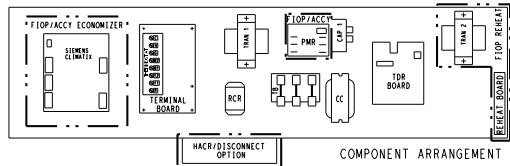

- NOTES:**
1. TERMINAL BOARD SCHEMATIC LAYOUT DOES NOT MATCH ACTUAL TERMINAL BOARD LAYOUT.
 2. TERMINAL BOARD JUMPERS 1, 2 AND 3 ARE CUT FOR REHEAT UNITS ONLY.
 3. REMOVE DESIGNATED JUMPERS ON TERMINAL BOARD WHEN ADDING SMOKE DETECTORS, OCCUPANCY AND REMOTE SHUTDOWN.
 4. USE ABC AS COURSE AND AS POT FINE ADJUSTMENTS FOR SETTING HIGH FAN SPEED. LOW SPEED IS AN OFFSET BASED ON DIP SWITCHES.
 5. 2-PIN LOW SPEED DIP SWITCH POSITIONS ARE FACTORY SET AS SHOWN.
 6. THE * WIRE COLOR IS FOR DIFFERENTIATION WITHIN THIS SCHEMATIC.
 7. COMPRESSOR LEADER PLUG CONTAINS BRIDGE RECTIFIER TO CONVERT AC TO DC.
 8. TB4 LOCATED IN HEAT SECTION.
 9. TO CONVERT TO A SINGLE STAGE HEATER NOTE VIOLET WIRE AT TB4 TO CONNECT WITH WHITE WIRE.
 10. THE ORANGE WIRE EXISTING COMP # WILL REMAIN UNCONNECTED FOR CORRECT UNIT OPERATION.

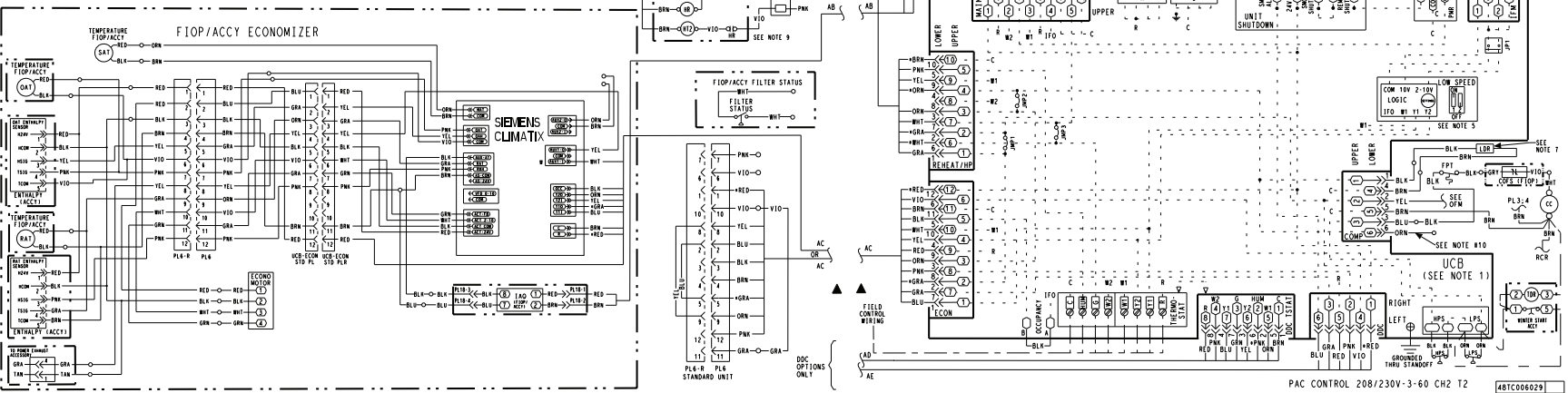

Typical Control Wiring Diagram — 50GC 06 460/575-3-60 Unit Shown with Electromechanical Control and POL224 Economizer

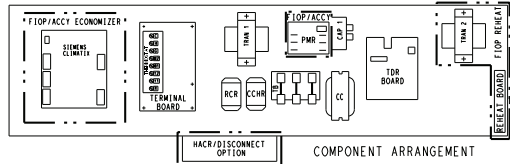

- NOTES:**
1. TERMINAL BOARD SCHEMATIC LAYOUT DOES NOT MATCH ACTUAL TERMINAL BOARD LAYOUT.
 2. TERMINAL BOARD JUMPERS 1, 2 AND 3 ARE CUT FOR REHEAT UNITS ONLY.
 3. REMOVE DESIGNATED JUMPERS ON TERMINAL BOARD WHEN ADDING SMOKE DETECTORS, OCCUPANCY AND REMOTE SHUTDOWN.
 4. USE ABC AS COURSE AND POT AS FINE ADJUSTMENTS FOR SETTING HIGH FAN SPEED. LOW SPEED IS AN OFFSET BASED ON DIP SWITCHES.
 5. 2-PIN LOW SPEED DIP SWITCH POSITIONS ARE FACTORY SET AS SHOWN.
 6. THE * WIRE COLOR IS FOR DIFFERENTIATION WITHIN THIS SCHEMATIC.
 7. COMPRESSOR LOADER PLUG CONTAINS BRIDGE RECTIFIER TO CONVERT AC TO DC.
 8. T84 LOCATED IN HEAT SECTION.
 9. TO CONVERT TO A SINGLE STAGE HEATER MOVE VIOLET WIRE AT T84 TO CONNECT WITH WHITE WIRE.
 10. THE ORANGE WIRE EXITING COMP-6 WILL REMAIN UNCONNECTED FOR CORRECT UNIT OPERATION.

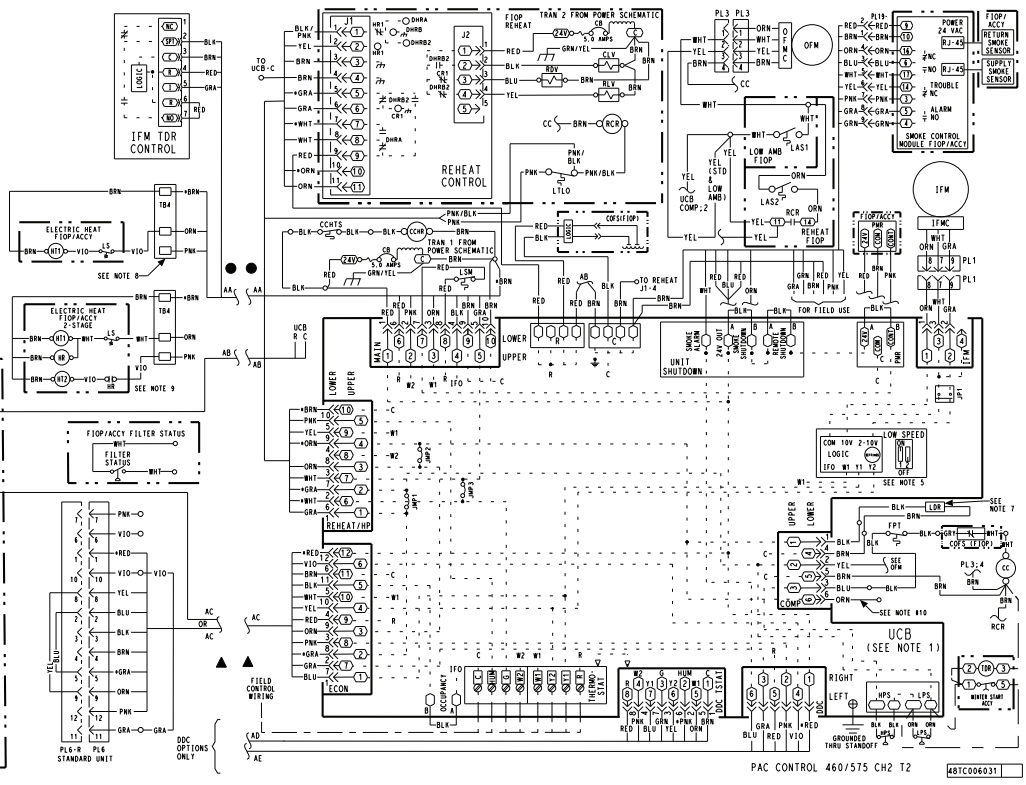
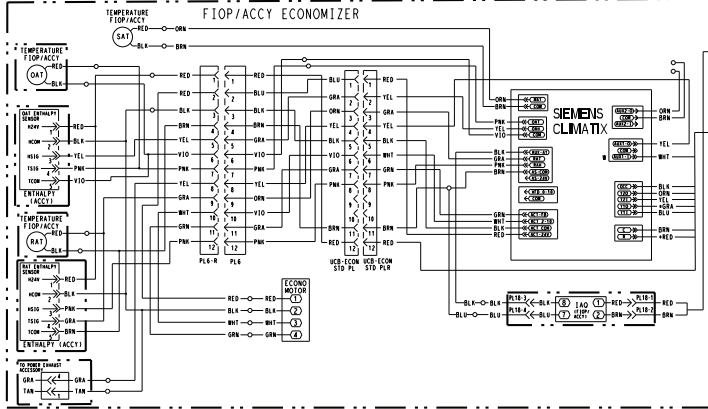

Typical 50GC 04-06 Power Wiring Diagram, 208/230-3-60 Unit Shown

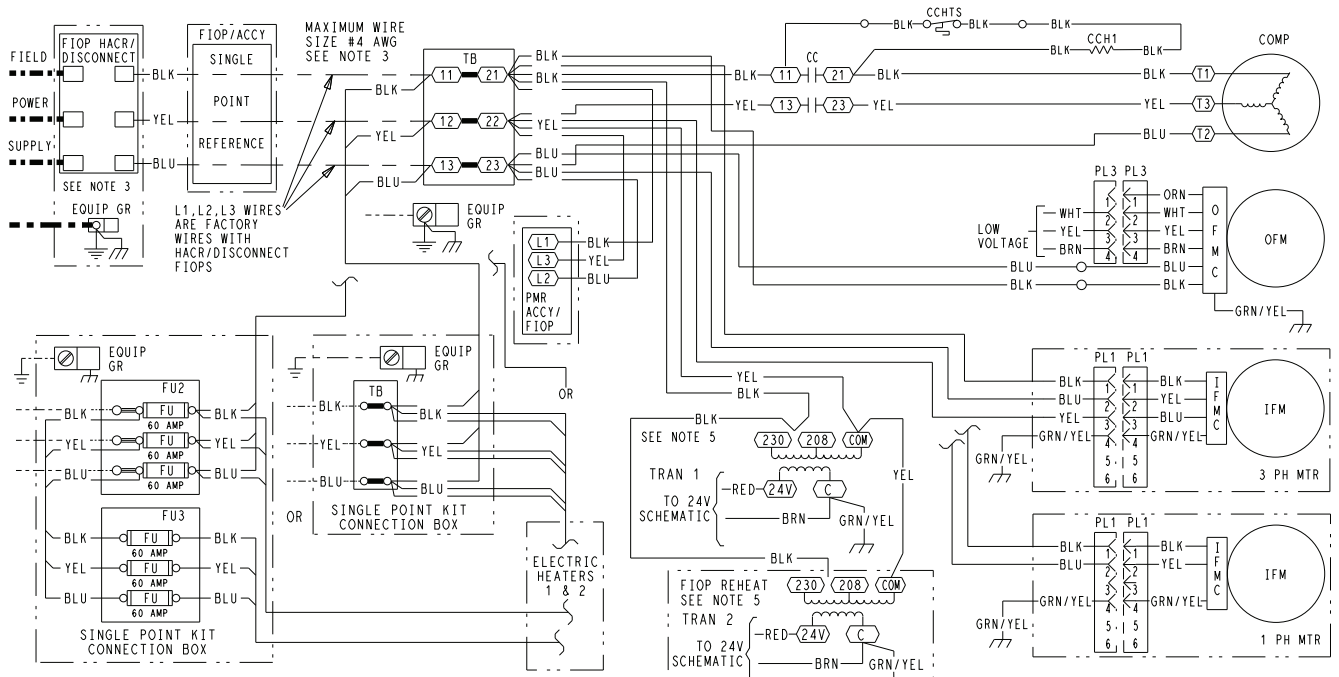

PAC POWER 208/230V-3-60H
CH1-2 T2

- NOTES**
1. IF ANY OF THE ORIGINAL WIRE FURNISHED MUST BE REPLACED, IT MUST BE REPLACED WITH TYPE 90° C WIRE OR ITS EQUIVALENT.
 2. COMPRESSOR AND FAN MOTORS ARE THERMALLY PROTECTED.
 3. USE COPPER CONDUCTOR ONLY.
 4. DO NOT DISCONNECT POWER PLUG OR SIGNAL WIRE WHILE UNDER LOAD.
 5. ON 208/230V UNITS, TRAN IS WIRED FOR 230V. IF UNIT IS TO BE RUN WITH 208V POWER SUPPLY, DISCONNECT BLK WIRE FROM 230V TAP AND CONNECT TO 208V TAP.

LEGEND

- (X) MARKED WIRE
- (X) TERMINAL (MARKED)
- () TERMINAL (UNMARKED)
- (Y) TERMINAL BLOCK
- SPLICE
- SPLICE (MARKED)
- FACTORY WIRING
- FIELD CONTROL WIRING
- FIELD POWER WIRING
- CIRCUIT BOARD TRACE
- - - ACCESSORY OR OPTIONAL WIRING

- ACCY ACCESSORY
- AWG AMERICAN WIRE GAGE
- BAS BUILDING AUTOMATION NETWORK
- CC CONTACTOR, COMPRESSOR
- C COMMON
- CAP CAPACITOR
- CB CIRCUIT BREAKER
- CCH CRANKCASE HEATER
- CCHR CRANKCASE HEATER RELAY
- CCHTS CRANKCASE HEATER TEMP SWITCH
- CLO COMPRESSOR LOCKOUT
- CLV COOLING LIQUID VALVE
- COFS CONDENSATE OVERFLOW SWITCH
- COM SIGNAL COMMON
- COMP COMPRESSOR MOTOR
- DDC DIRECT DIGITAL CONTROL
- DFB DEFROST BOARD
- DFT DEFROST THERMOSTAT
- EHR ELECTRIC HEAT RELAY
- ENTH ENTHALPY
- ERV ENERGY RECOVERY VENTILATOR
- ESL ENTHALPY SENSOR - LOW
- FB FUSE BLOCK
- F1OP FACTORY INSTALLED OPTION
- FPT FREEZE PROTECTION THERMOSTAT
- FST FAN HOUSING TEMP SENSOR
- FU FUSE

- G GR(ND)
- HACR HEATING, AIR-CONDITIONING, REFRIGERATION BREAKER
- HR HEATER RELAY
- HGRH HOT GAS REHEAT
- HPC HEAD PRESSURE CONTROL
- HPS HIGH PRESSURE SWITCH
- HUM HUMIDISTAT
- IAQ INDOOR AIR QUALITY SENSORS
- IFM INDOOR FAN MOTOR
- IFMC INDOOR FAN MOTOR CONTROL
- IFO INDOOR FAN ON SIGNAL
- IRH INDOOR RELATIVE HUMIDITY
- JMP JUMPER
- L1 LOW AMBIENT LOCKOUT
- LAR LOW AMBIENT RELAY
- LAS LOW AMBIENT SWITCH
- LDR COMPRESSOR LOADER
- LEN LOCAL EQUIPMENT NETWORK
- LOC LOSS OF CHARGE
- LOOP PWR CURRENT LOOP POWER
- LPS LOW PRESSURE SWITCH
- LS LIMIT SWITCH
- LSM LIMIT SWITCH (MANUAL RESET)
- LTLO LOW TEMP LOCKOUT

- MBB MAIN BASE BOARD
- MOV METAL OXIDE VARISTOR
- MTR MOTOR
- OAQ OUTDOOR AIR QUALITY
- OAT OUTDOOR AIR TEMP. SEN
- OFM OUTDOOR FAN MOTOR
- OFMC OUTDOOR FAN MOTOR CONTROL
- OFR OUTDOOR FAN RELAY
- OL OVERLOAD
- PER POWER EXHAUST RELAY
- PH PHASE
- PL PLUG ASSEMBLY
- POT POTENTIOMETER
- PMR PHASE MONITOR RELAY
- PS PRESSURE SWITCH
- PWM PULSE WIDTH MODULATION
- QT QUADRUPLE TERMINAL
- R THERMOSTAT POWER
- RAT RETURN AIR TEMP. SEN
- RCR REHEAT CONTROL RELAY
- RDV REHEAT DISCHARGE VALVE
- RH RELATIVE HUMIDITY
- RLV REHEAT LIQUID VALVE
- RNET LOCAL ACCESS NETWORK
- RVS REVERSING VALVE SOLENOID
- SAT SUPPLY AIR TEMP SENSOR
- SDP SYSTEM DISCHARGE PRESSURE
- SPRH SPACE RELATIVE HUMIDITY
- SPT SPACE TEMPERATURE SENSOR
- SPTO SPACE TEMPERATURE OFFSET
- SSP SYSTEM SUCTION PRESSURE
- SW SWITCH
- TB TERMINAL BLOCK
- TDR TIME DELAY RELAY
- TRAN TRANSFORMER
- UCB UNIT CONTROL BOARD
- W1 1st STAGE OF HEATING CALL
- W2 2nd STAGE OF HEATING CALL
- Y1 1st STAGE OF COOLING CALL
- Y2 2nd STAGE OF COOLING CALL

48TC005572 B

Typical 50GC 04-05 Power Wiring Diagram, 460/575-3-60 Unit Shown

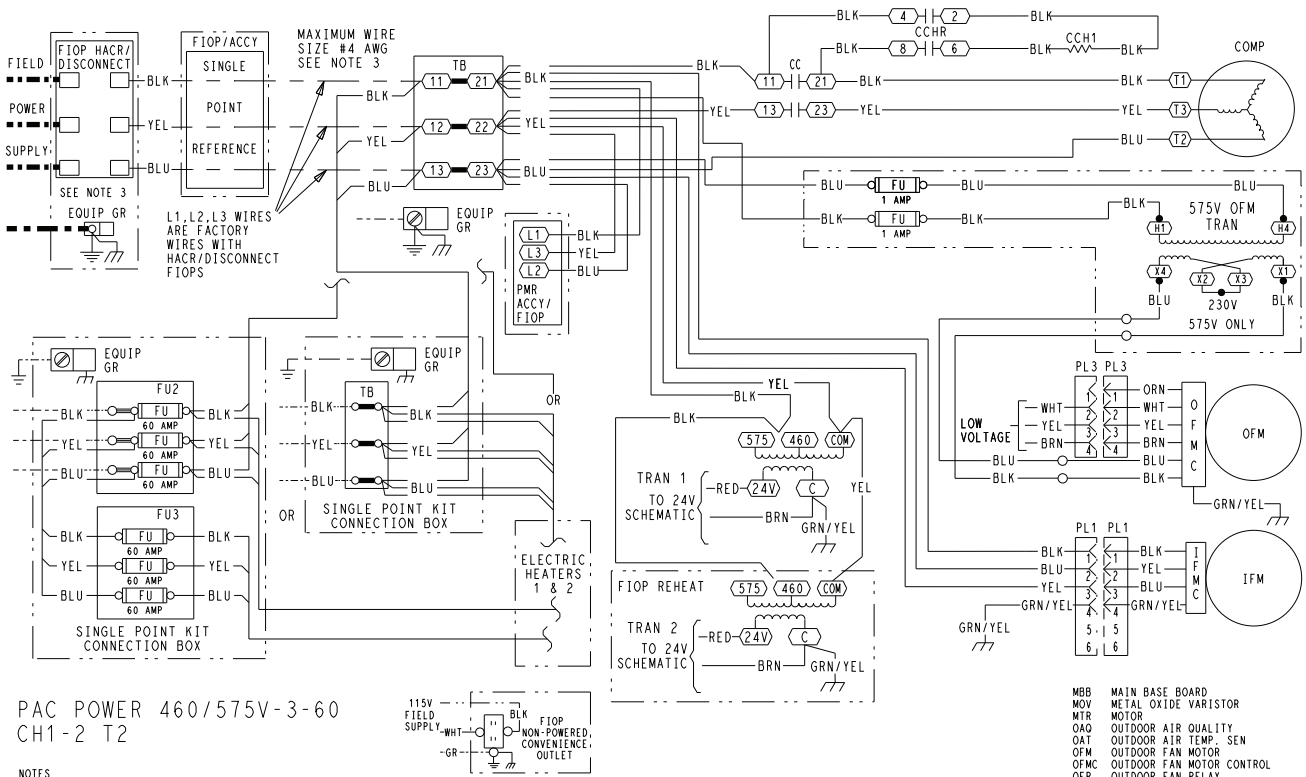

PAC POWER 460/575V-3-60
CH1-2 T2

- NOTES
- IF ANY OF THE ORIGINAL WIRE FURNISHED MUST BE REPLACED, IT MUST BE REPLACED WITH TYPE 90° C WIRE OR ITS EQUIVALENT.
 - COMPRESSOR AND FAN MOTORS ARE THERMALLY PROTECTED.
 - USE COPPER CONDUCTOR ONLY.
 - DO NOT DISCONNECT POWER PLUG OR SIGNAL WIRE WHILE UNDER LOAD.
 - TRANSFORMER IS DEDICATED BASED ON UNIT VOLTAGE. TAPS ONLY SHOWN TO SIMPLIFY SCHEMATIC.

LEGEND

- X MARKED WIRE
- X TERMINAL (MARKED)
- TERMINAL (UNMARKED)
- X TERMINAL BLOCK
- SPLICE
- SPLICE (MARKED)
- FACTORY WIRING
- - - - - FIELD CONTROL WIRING
- FIELD POWER WIRING
- - - - - CIRCUIT BOARD TRACE
- - - - - ACCESSORY OR OPTIONAL WIRING

- | | | | | | |
|-------|------------------------------|--------|-----------------------------|------|--|
| ACCY | ACCESSORY | 6 | GR(ND) | 6 | GROUND |
| AWG | AMERICAN WIRE GAGE | BAS | BUILDING AUTOMATION NETWORK | HACR | HEATING, AIR-CONDITIONING, REFRIGERATION BREAKER |
| CC | CONTACTOR, COMPRESSOR | C | COMMON | HR | HEATER RELAY |
| CAP | CAPACITOR | HRH | HOT GAS REHEAT | HPC | HEAD PRESSURE CONTROL |
| CB | CIRCUIT BREAKER | HPS | HIGH PRESSURE SWITCH | HUM | HUMIDISTAT |
| CCH | CRANKCASE HEATER | IAQ | INDOOR AIR QUALITY SENSORS | IFM | INDOOR FAN MOTOR |
| CCHR | CRANKCASE HEATER RELAY | IFMC | INDOOR FAN MOTOR CONTROL | IFO | INDOOR FAN ON SIGNAL |
| CCHTS | CRANKCASE HEATER TEMP SWITCH | IRH | INDOOR RELATIVE HUMIDITY | JMP | JUMPER |
| CLO | COMPRESSOR LOCKOUT | LINE 1 | LINE 1 | LA | LOW AMBIENT LOCKOUT |
| CLV | COOLING LIQUID VALVE | LAR | LOW AMBIENT RELAY | LAS | LOW AMBIENT SWITCH |
| COPFS | CONDENSATE OVERFLOW SWITCH | LDR | COMPRESSOR LOADER | LEN | LOCAL EQUIPMENT NETWORK |
| COM | SIGNAL COMMON | LOC | LOSS OF CHARGE | LOOP | CURRENT LOOP POWER |
| COMP | COMPRESSOR MOTOR | LPS | LOW PRESSURE SWITCH | LS | LIMIT SWITCH |
| DDC | DIRECT DIGITAL CONTROL | LSM | LIMIT SWITCH (MANUAL RESET) | LTLO | LOW TEMP LOCKOUT |
| DFB | DEFROST BOARD | | | | |
| DFT | DEFROST THERMOSTAT | | | | |
| EHR | ELECTRIC HEAT RELAY | | | | |
| ENTH | ENTHALPY | | | | |
| ERV | ENERGY RECOVERY VENTILATOR | | | | |
| ESL | ENTHALPY SENSOR - LOW | | | | |
| FB | FUSE BLOCK | | | | |
| FIOP | FACTORY INSTALLED OPTION | | | | |
| FPT | FREEZE PROTECTION THERMOSTAT | | | | |
| FST | FAN HOUSING TEMP SENSOR | | | | |
| FU | FUSE | | | | |

48TC005577 A

General

The sequence below describes the sequence of operation for an electro-mechanical unit with and without a factory-installed EconomizerONE (POL224 controller; called “economizer” in this sequence). For information regarding a direct digital controller, see the start-up, operations, and troubleshooting manual for the applicable controller.

Electromechanical units without economizer

Cooling (2-stage units)

When the thermostat calls for cooling, terminals G and Y1 are energized. The indoor fan will run at the low fan speed and the compressor contactor (CC) is energized causing the compressor and outdoor fan to turn on. The low indoor fan speed is 75% of the user set fan speed, the compressor will run at partial capacity, and the outdoor fan will run at low speed.

If additional cooling is needed, the thermostat will add the call for Y2. This will increase the indoor fan speed to the user set fan speed, energize the compressor loader for full compressor capacity, and energize the outdoor fan relay (OFR) for high speed.

When the thermostat removes the call for Y2 but leaves the Y1, the indoor fan will reduce speed to 75% of the user set fan speed, the compressor loader will turn off, and the outdoor fan will drop to low speed. When the thermostat removes the call for Y1 the compressor contactor will de-energize shutting down the compressor and the outdoor fan. When the thermostat removes the call for G, the indoor fan will turn off after the specific unit fan off delay.

Gas heating (48GC units)

When the thermostat calls for heating, power is sent to W on the Integrated Gas Controller (IGC) board. An LED (light-emitting diode) on the IGC board turns on and remains on during normal operation. A check is made to ensure that the roll-out switch and limit switch are closed. If the check was successful, the induced-draft motor is energized, and when its speed is satisfactory, as proven by the flue gas pressure switch, the ignition activation period begins. The burners will ignite within 5 seconds. If the burners do not light, there is a 22 second delay before another 5-second attempt. This sequence is repeated for 15 minutes or until the burners light. If, after the 15 minutes, the burners still have not lit, heating is locked out. To reset the control, break 24 V power to the thermostat.

When ignition occurs, the IGC board will continue to monitor the condition of the roll-out switch, the limit switches, the flue gas pressure switch, as well as the flame sensor. 45 seconds after ignition occurs, assuming the unit is controlled through a room thermostat set for fan auto, the indoor-fan motor will energize (and the outdoor-air dampers will open to their minimum position). If, for some reason, the over-temperature limit opens prior to the start of the indoor fan blower, the unit will shorten the 45-second delay to 5 seconds less than the time from initiation of heat to when the limit tripped. Gas will not be interrupted to the burners and heating will continue. Once the fan-on delay has been modified, it will not change back to 45 seconds until power is reset to the control. On units with 2 stages of heat, when additional heat is required, W2 closes and initiates power to the second stage of the main gas valve. When the thermostat is satisfied, W1 and W2 open and the gas valve closes, interrupting the flow of gas to the

main burners. If the call for W1 lasted less than 1 minute, the heating cycle will not terminate until 1 minute after W1 became active. If the unit is controlled through a room thermostat set for fan auto, the indoor-fan motor will continue to operate for an additional 45 seconds then stop. If the over-temperature limit opens after the indoor motor is stopped, but within 10 minutes of W1 becoming inactive, on the next cycle the time will be extended by 15 seconds. The maximum delay is 3 minutes. Once modified, the fan off delay will not change back to 45 seconds unless power is reset to the control. A LED indicator is provided on the IGC to monitor operation.

Electric heating (50GC units)

NOTE: 50GC units are sold as cooling only. If electric heaters are required, use only factory-approved heaters. They will operate as follows.

Units have either 1 or 2 stages of electric heat. When the thermostat calls for heating, power is applied to G and the W1 terminals at the unit. The unit control will energize the indoor fan contactor and the first stage of electric heat. On units with 2-stage heating, when additional heating is required, the second stage of electric heat (if equipped) will be energized when power is applied at the W2 terminal on the unit.

IMPORTANT: The thermostat must be configured for Electric Heat so it will energize G with the W1 call.

Electromechanical units with factory-installed EconomizerONE

Cooling

When free cooling is not available, the compressors will be controlled by the zone thermostat. When free cooling is available, the outdoor-air damper is modulated by the EconomizerONE control to provide a 50°F (10°C) to 55°F (13°C) mixed-air temperature into the zone. As the mixed air temperature fluctuates above 55°F (13°C) or below 50°F (10°C) dampers will be modulated (open or close) to bring the mixed-air temperature back within control. If mechanical cooling is utilized with free cooling, the outdoor-air damper will maintain its current position at the time the compressor is started. If the increase in cooling capacity causes the mixed-air temperature to drop below 45°F (7°C), then the outdoor-air damper position will be decreased to the minimum position. If the mixed-air temperature continues to fall, the outdoor-air damper will close. Control returns to normal once the mixed-air temperature rises above 48°F (9°C). The power exhaust fans will be energized and de-energized, if installed, as the outdoor-air damper opens and closes.

If field-installed accessory CO₂ sensors are connected to the EconomizerONE control, a demand controlled ventilation strategy will begin to operate. As the CO₂ level in the zone increases above the CO₂ setpoint (on the EconomizerONE controller), the minimum position of the damper will be increased proportionally until the Maximum Ventilation setting is reached. As the CO₂ level decreases because of the increase in fresh air, the outdoor-air damper will follow the higher demand condition from either the DCV mode or from the free cooling mode. For EconomizerONE operation, there must be a thermostat call for the fan (G). If the unit is occupied and the fan is on, the damper will operate at minimum position. Otherwise, the damper will be closed.

Sequence of operation (cont)



When the EconomizerONE control is in the occupied mode and a call for cooling exists (Y1 on the thermostat), the control will first check for indoor fan operation. If the fan is not on, then cooling will not be activated. If the fan is on, then the control will open the EconomizerONE damper to the minimum position.

On the initial power to the EconomizerONE control, it will take the damper up to 2-1/2 minutes before it begins to position itself. After the initial power-up, further changes in damper position can take up to 90 seconds to initiate. Damper movement from full closed to full open (or vice versa) will take between 1-1/2 and 2-1/2 minutes. If free cooling can be used as determined from the appropriate changeover command (dry bulb, outdoor enthalpy, differential dry bulb, or differential enthalpy), then the control will modulate the dampers open and closed to maintain the mixed-air temperature setpoint at 50°F (10°C) to 55°F (13°C). If there is a further demand for cooling (cooling second stage — Y2 is energized), then the control will bring on compressor stage 1 to maintain the mixed-air temperature setpoint. The EconomizerONE damper will be open at maximum position.

2-Speed Note: When operating in ventilation mode only, the indoor fan motor will automatically adjust to 75% of the total cfm established.

Heating

The sequence of operation for heating is the same as an electro-mechanical unit without an economizer. The only difference is how the economizer acts. The economizer will stay at the Economizer Minimum Position while the evaporator fan is operating. The outdoor-air damper is closed when the indoor fan is not operating. Refer to Service and Maintenance manual for further details.

Optional Humidi-MiZer® dehumidification system

Units with the factory equipped Humidi-MiZer system option are capable of providing multiple modes of improved dehumidification as a variation of the normal cooling cycle. The Humidi-MiZer system option includes additional valves in the liquid line and discharge line of each refrigerant circuit, a small reheat condenser coil downstream of the evaporator, and variable-speed control of some or all outdoor fans. Operation of the revised refrigerant circuit for each mode is described below.

The Humidi-MiZer system provides 3 sub-modes of operation: Cool, Reheat1, and Reheat2.

Cool mode — Provides a normal ratio of Sensible and Latent Cooling effect from the evaporator coil.

Reheat1 — Provides increased Latent Cooling while slightly reducing the Sensible Cooling effect.

Reheat2 — Provides normal Latent Cooling but with null or minimum Sensible Cooling effect delivered to the space.

The Reheat1 and Reheat2 modes are available when the unit is not in a Heating mode and when the Low Ambient Lockout switch is closed.

The figures on this page depict piping for 2-stage cooling units.

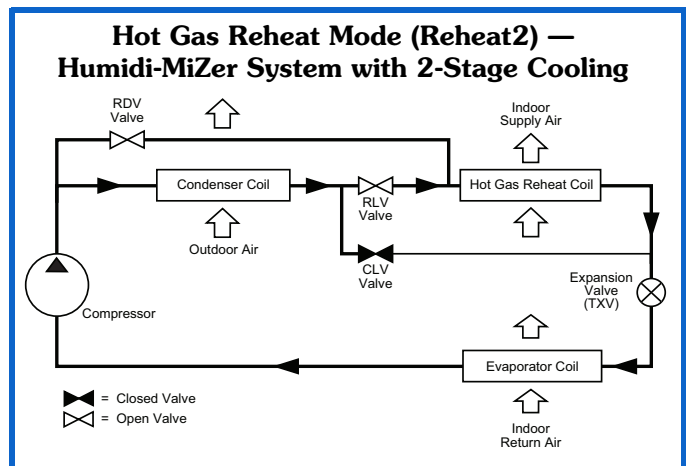
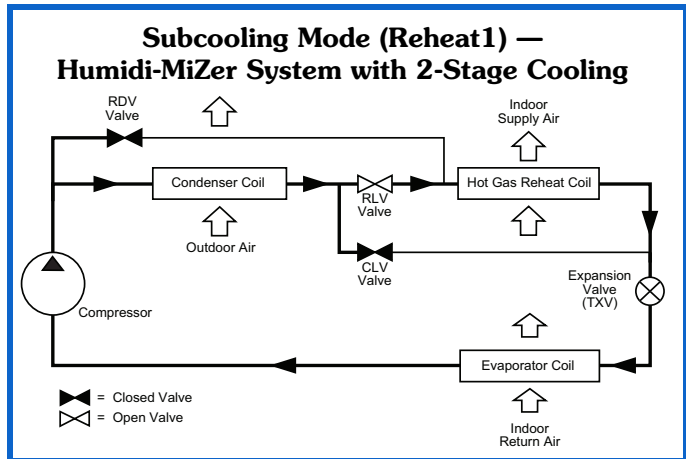
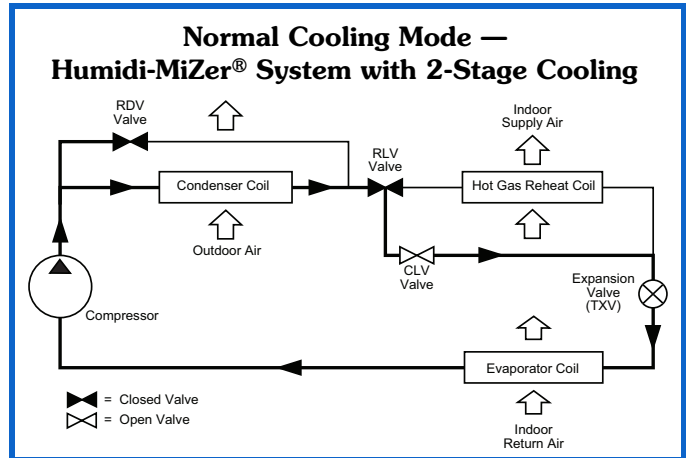

Sequence of operation (cont)



RTU Open controller (factory option)

For details on operating 48/50GC units equipped with the factory-installed RTU Open controller option, refer to Factory Installed RTU Open Multi-Protocol Controller Controls, Start-Up, Operation and Troubleshooting manual.

SystemVu™ controller (factory option)

For details on operating 48/50GC units equipped with the factory-installed SystemVu controller option, refer to FC/GC Series Single Package Rooftop Units with SystemVu Controller Controls, Start-Up, Operation and Troubleshooting manual.

Minimum operating ambient temperature (cooling)

In mechanical cooling mode, your Carrier rooftop unit can safely operate down to an outdoor ambient temperature of 35°F (2°C). It is possible to provide cooling at lower outdoor ambient temperatures by using less outside air, economizers, and/or accessory low ambient kits.

Maximum operating ambient temperature (cooling)

The maximum operating ambient temperature for cooling mode is 125°F (52°C). While cooling operation above 125°F (52°C) may be possible, it could cause either a reduction in performance, reliability, or a protective action by the unit's internal safety devices.

Multiple motor and drive packages

Some applications need larger horsepower motors, some need more airflow, and some need both. Regardless of the case, your Carrier expert has a factory installed combination to meet your application. A wide selection of motors and pulleys (drives) are available, factory installed, to handle nearly any application.

Stainless steel heat exchanger (48GC units only)

The stainless steel heat exchanger option provides the tubular heat exchanger be made out of a minimum 20 gauge type 409 stainless steel for applications where the mixed air to the heat exchanger is expected to drop below 45°F (7°C). Stainless steel may be specified on applications where the presence of airborne contaminants require its use (applications such as paper mills) or in area with very high outdoor humidity that may result in severe condensation in the heat exchanger during cooling operation.

Minimum mixed air temperature (heating) (48GC units only)

Using the factory settings, the minimum temperatures for the mixed air (the combined temperature of the warm return air and the cold outdoor air) entering the dimpled, gas heat exchangers are shown in the following table.

Minimum Temperature for Mixed Air Temperature

ALUMINIZED	STAINLESS STEEL
50°F (10°C) Continuous	40°F (4°C) Continuous
45°F (7°C) Intermittent	35°F (2°C) Intermittent

Operating at lower mixed-air temperatures may be possible, if a field-supplied, outdoor air thermostat initiates both heat stages when the temperature is less than the minimum temperatures listed above. Please contact your local Carrier representative for assistance.

Minimum and maximum airflow (heating and cooling)

To maintain safe and reliable operation of your rooftop, operate within the heating airflow limits during heating mode and cooling airflow limits during cooling mode. Operating above the maximum may cause blow-off, undesired airflow noise, or airflow related problems with the rooftop unit. Operating below the minimum may cause problems with coil freeze-up and unsafe heating operation. Heating and cooling limitations differ when evaluating operating cfm, the minimum value is the HIGHER of the

cooling and heating minimum cfm values published on page 8 and the maximum value is the LOWER of the cooling and heating minimum values published on page 8.

Heating-to-cooling changeover

Your unit will automatically change from heating to cooling mode when using a thermostat with an auto-changeover feature.

Airflow

All units are draw-through in cooling mode and blow-through in heating mode.

Outdoor air application strategies

Economizers reduce operating expenses and compressor run time by providing a free source of cooling and a means of ventilation to match application changing needs. In fact, they should be considered for most applications. Also, consider the various economizer control methods and their benefits, as well as sensors required to accomplish your application goals. Please contact your local Carrier representative for assistance.

Motor limits, break horsepower (bhp)

Due to internal design of Carrier units, the air path, and specially designed motors, the full horsepower (maximum continuous bhp) band, as listed in the Fan Performance tables, can be used with the utmost confidence. There is no need for extra safety factors, as Carrier motors are designed and rigorously tested to use the entire, listed bhp range without either nuisance tripping or premature motor failure.

Propane heating (48GC units only)

Propane has different physical qualities than natural gas. As a result, propane requires different fuel to air mixture. To optimize the fuel/air mixture for propane, Carrier sells different burner orifices in an easy to install accessory kit. To select the correct burner orifices or determine the heat capacity for a propane application, use either the selection software, or the unit's service manual.

High altitude heating

High altitudes have less oxygen, which affects the fuel/air mixture in heat exchangers. In order to maintain a proper fuel/air mixture, heat exchangers operating in altitudes above 2000 ft (610 m) require different orifices. To select the correct burner orifices or determine the heat capacity for a high altitude application, use either the selection software, or the unit's service manual.

High altitudes have less oxygen, which means heat exchangers need less fuel. The new gas orifices in this field-installed kit make the necessary adjustment for high altitude applications. They restore the optimal fuel to air mixture and maintain healthy combustion on altitudes above 2000 ft (610 m).

NOTE: Typical natural gas heating value ranges from 975 to 1050 Btu/ft³ at sea level nationally. The heating value goes down approximately 1.7% per every thousand feet elevation. Standard factory orifices can typically be used up to 2000 ft (610 m) elevation without any operational issues.

Sizing a rooftop

Bigger is not necessarily better. While an air conditioner needs to have enough capacity to meet the design loads, it

does not need excess capacity. In fact, excess capacity typically results in very poor part load performance and humidity control.

Using higher design temperatures than ASHRAE recommends for your location, adding “safety factors” to the calculated load, are all signs of oversizing air conditioners. Oversizing the air conditioner leads to poor humidity control, reduced efficiency, higher utility bills, larger indoor temperature swings, excessive noise, and increased wear and tear on the air conditioner.

Rather than oversizing an air conditioner, engineers should “right-size” or even slightly “under-size” air conditioners. Correctly sizing an air conditioner controls humidity better; promotes efficiency; reduces utility bills; extends equipment life, and maintains even, comfortable temperatures. Please contact your local Carrier representative for assistance.

Low ambient applications

The optional Carrier economizer can adequately cool your space by bringing in fresh, cool outside air. In fact, when so equipped, accessory low-ambient kit may not be necessary. In low ambient conditions, unless the outdoor air is excessively humid or contaminated, economizer-based “free cooling” is the preferred less costly and energy conscious method. In low ambient applications where outside air might not be desired (such as contaminated or excessively humid outdoor environments), your Carrier rooftop can operate to ambient temperatures down to -20°F (-29°C) using the recommended accessory low ambient controller.

Two-stage cooling operation

Use appropriate 2-stage thermostat to achieve the unit’s optimum design comfort and overall operating performance.

Note about this specification:

This specification is in the “Masterformat” as published by the Construction Specification Institute. Please feel free to copy this specification directly into your building spec.



High Efficiency Gas Heat/Electric Cooling Packaged Rooftop

HVAC Guide Specifications

Size Range: **3 to 5 Nominal Tons**

Carrier Model Number: **48GC**04-06**

Part 1 — (23 06 80) Schedules for Decentralized HVAC Equipment

1.01 (23 06 80.13) Decentralized Unitary HVAC Equipment Schedule:

- A. 23 06 80.13.A.) Rooftop Unit (RTU) Schedule:
 1. Schedule is per the project specification requirements.

Part 2 — (23 07 16) HVAC Equipment Insulation

2.01 (23 07 16.13) Decentralized, Rooftop Units:

- A. (23 07 16.13.A.) Evaporator Fan Compartment:
 1. Interior cabinet surfaces shall be insulated with a minimum 1/2 in. thick, minimum 1-1/2 lb density, flexible fiberglass insulation bonded with a phenolic binder, neoprene coated on the air side.
 2. Insulation and adhesive shall meet NFPA 90A requirements for flame spread and smoke generation.
- B. (23 07 16.13.B.) Gas Heat Compartment:
 1. Aluminum foil-faced fiberglass insulation shall be used.
 2. Insulation and adhesive shall meet NFPA 90A requirements for flame spread and smoke generation.

Part 3 — (23 09 13) Instrumentation and Control Devices for HVAC

3.01 (23 09 13.23) Sensors and Transmitters:

- A. (23 09 13.23.A.) Thermostats:
 1. Thermostat must:
 - a. energize both “W” and “G” when calling for heat.
 - b. have capability to energize 2 stages of cooling, and 2 different stages of heating.
 - c. include capability for occupancy scheduling.

Part 4 — (23 09 23) Direct Digital Control System for HVAC

4.01 (23 09 23.13) Decentralized, Rooftop Units:

- A. (23 09 23.13.A.) SystemVu™ intelligent integrated Direct Digital Control (DDC) shall provide:
 1. Integrated unit operation for comfort cooling, heating ventilation as well as all monitoring, recording and reporting capabilities. Controller

shall also provide diagnostics and alarms of abnormal unit operation through the controller. Controller shall have an intuitive user display and be able to be used in a standalone operation or via building automation system (BAS).

2. Quick Unit Status LEDs of: Run — meaning all systems are go, ALERT — that indicates there is currently a non-critical issue with the unit, like filters need to be replaced and FAULT — that indicates the unit has a critical issue and will possibly shut down.
3. Six large navigation keys for easy access. Navigation keys shall consist of: TEST, BACK, ENTER, and MENU along with UP and DOWN arrows.
4. Full back lit user display with 4 line by 30 character text capabilities. Display menu shall be designed to provide guided major menus and sub menus main menus provided below:
 - a. Shutdown Unit
 - b. Run Status
 - c. Settings
 - d. Alerts/Faults
 - e. Service
 - f. Inputs
 - g. Outputs
 - h. USB
5. The capability for standalone operation with conventional thermostat/sensor or use with building automation systems (BAS) of Carrier i-Vu®, BACnet™1 and Carrier Comfort Network® (CCN) systems. No special modules or boards are required for these capabilities. Has the capability to work with Equipment Touch™ and System Touch™ devices and ZS Sensors.
6. The ability to read refrigerant pressures at display or via BAS network of; Discharge Pressure and Suction Pressure. The need for traditional refrigerant gauges is not required.
7. USB Data Port for flash drive interaction. This will allow the transfer of data for uploads, downloads, perform software upgrades, back-up and restore data and file transfer data such as component number of starts and run hours.
8. Reverse Rotation Protection of compressors if field 3-phase wiring is misapplied.
9. Provide Service Capabilities of:
 - a. Auto run test
 - b. Manual run test
 - c. Component run hours and starts
 - d. Commissioning reports
 - e. Data logging
 - f. Alarm history

1. Third-party trademarks and logos are the property of their respective owners.

10. Economizer control and diagnostics. Set up economizer operation, receive feedback from actuator. Also meets the most recent California Title 24, ASHRAE 90.1 and IECC Fault Detection and Diagnostic (FDD) requirements.
 11. Unit cooling operation down to 35°F (2°C).
 12. Controller shall have easy access connections around the controller perimeter area and consist of Mate-N-Lok^{®1}, terminal block and RJ style modular jack connections.
 13. 365 day real time clock, 20 holiday schedules along with occupied and unoccupied scheduling.
 14. Auto-Recognition for easy installation and commissioning of devices like economizers, space sensors etc.
 15. A 5°F (3°C) temperature difference between cooling and heating setpoints to meet the latest ASHRAE 90.1 Energy Standard.
 16. Contain return air sensor, supply air sensor and outdoor air sensor to help monitor and provide data for the unit comfort operation, diagnostic and alarms.
 17. Use of Carrier's field accessory hand-held Navigator™ display, Equipment Touch and System Touch devices.
 18. Units with the factory-installed Humidi-MiZer[®] system option are capable of providing multiple modes of improved dehumidification as a variation of the normal cooling cycle.
 19. Supply Air Tempering control operates the gas or electric heat to maintain a minimum supply air temperature during conditions where very cold outdoor air causes the supply air temperature to fall below the configured Supply Air Tempering Setpoint. This occurs during periods where DCV is active and increasing the amount of outdoor air or in cases where the system is operating at very low airflow and the calculated economizer position has increased to maintain a constant ventilation rate.
 20. Demand limiting in SystemVu™ is achieved through setpoint expansion. The systems heating and cooling setpoints are expanded in steps or levels. The degree to which the setpoints may be expanded is defined by the 6 demand level offsets and the 2 commanded demand limit levels.
 21. 3-year limited part warranty.
- B. (23 09 23.13.B.) RTU Open Protocol, Direct Digital Controller:
1. Shall be ASHRAE 62 compliant.
 2. Shall accept 18-30 vac, 50-60 Hz, and consume 15VA or less power.
3. Shall have an operating temperature range from -40°F (-40°C) to 130°F (54°C), 10% to 90% RH (non-condensing).
 4. Shall include built-in protocol for BACnet™1 (MS/TP and PTP modes), Modbus^{®1} (RTU and ASCII), Johnson Controls^{®1} N2 and LonWorks^{®1}. LonWorks Echelon processor required for all Lon applications shall be contained in separate communication board.
 5. Shall allow access of up to 62 network variables (SNVT). Shall be compatible with all open controllers.
 6. Baud rate controller shall be selectable using a DIP switch.
 7. Shall have an LED display independently showing the status of serial communication, running, errors, power, all digital outputs, and all analog inputs.
 8. Shall accept the following inputs: space temperature, setpoint adjustment, outdoor air temperature, indoor air quality, outdoor air quality, compressor lock-out, fire shutdown, enthalpy switch, and fan status/filter status/humidity/remote occupancy.
 9. Shall provide the following outputs: economizer, fan, cooling stage 1, cooling stage 2, heat stage 1, heat stage 2, exhaust, reversing valve/high fan speed.
 10. Shall have built-in surge protection circuitry through solid-state polyswitches. Polyswitches shall be used on incoming power and network connections. Polyswitches will return to normal when the "trip" condition clears.
 11. Shall have a battery back-up capable of a minimum of 10,000 hours of data and time clock retention during power outages.
 12. Shall have built-in support for Carrier technician tool.
 13. Shall include an RS-485 protocol communication port, an access port for connection of either a computer or a Carrier technician tool, an RS-485 port for network communication to intelligent space sensors and displays, and a port to connect an optional LonWorks communications card.
 14. Software upgrades will be accomplished by either local or remote download. No software upgrades through chip replacements are allowed.

Part 5 — (23 09 33) Electric and Electronic Control System for HVAC

5.01 (23 09 33.13) Decentralized, Rooftop Units:

A. (23 09 33.13.A.) General:

1. Shall be complete with self-contained low-voltage control circuit protected by a resettable circuit breaker on the 24-v transformer side. Transformer shall have 75VA capability.

1. Third-party trademarks and logos are the property of their respective owners.

2. Shall utilize color-coded wiring.
 3. Shall include a Unit Control Board to conveniently and safely provide connection points for vital control functions such as: smoke detectors, phase monitor, gas controller, economizer, thermostat, DDC control options, and low and high pressure switches. Controller shall also provide an intuitive means to adjust the indoor fan speed through a simple switch and pot adjustment design.
 4. The heat exchanger shall be controlled by an integrated gas controller (IGC) microprocessor. See heat exchanger section of this specification.
 5. Unit shall include a minimum of one 8-pin screw terminal connection board for connection of control wiring.
- B. (23 09 33.13.B.) Safeties:
1. Compressor over-temperature, over-current. High internal pressure differential.
 2. Low Pressure Switch.
 - a. Low pressure switch shall use different color wire than the high pressure switch. The purpose is to assist the installer and service technician to correctly wire and or troubleshoot the rooftop unit.
 3. High Pressure Switch.
 - a. High pressure switch shall use different color wire than the low pressure switch. The purpose is to assist the installer and service technician to correctly wire and or troubleshoot the rooftop unit.
 4. Automatic Reset, Motor Thermal Overload Protector.
 5. Heating section shall be provided with the following minimum protections:
 - a. High temperature limit switches.
 - b. Induced draft motor speed sensor.
 - c. Flame rollout switch.
 - d. Flame proving controls.

Part 6 — (23 09 93) Sequence of Operations for HVAC Controls

- 6.01 (23 09 93.13) Decentralized, Rooftop Units:
- A. (23 09 93.13.A.) INSERT SEQUENCE OF OPERATION

Part 7 — (23 40 13) Panel Air Filters

- 7.01 (23 40 13.13) Decentralized, Rooftop Units:
- A. (23 40 13.13.A.) Standard Filter Section:
1. Shall consist of factory installed, low velocity, disposable 2 in. thick fiberglass filters of commercially available sizes.
 2. Unit shall use only one filter size. Multiple sizes are not acceptable.
 3. Filters shall be accessible through an access panel with “no-tool” removal as described in

the unit cabinet section of this specification (23 81 19.13.G).

Part 8 — (23 81 19) Self-Contained Air Conditioners

- 8.01 (23 81 19.13) Small-Capacity Self-Contained Air Conditioners:
- A. (23 81 19.13.A.) General:
1. Outdoor, rooftop mounted, electrically controlled, heating and cooling unit utilizing a fully hermetic scroll compressor(s) for cooling duty and gas combustion for heating duty.
 2. Factory assembled, single-piece heating and cooling rooftop unit. Contained within the unit enclosure shall be all factory wiring, piping, controls, and special features required prior to field start-up.
 3. Unit shall use Puron® (R-410A) refrigerant.
 4. Unit shall be installed in accordance with the manufacturer’s instructions.
 5. Unit must be selected and installed in compliance with local, state, and federal codes.
- B. (23 81 19.13.B.) Quality Assurance:
1. Unit meets and exceeds ASHRAE 90.1 minimum efficiency requirements.
 2. Unit shall be rated in accordance with AHRI Standards 210/240.
 3. Unit shall be designed to conform to ASHRAE 15.
 4. Unit shall be UL-tested and certified in accordance with ANSI Z21.47 Standards and UL-listed and certified under Canadian standards as a total package for safety requirements.
 5. Insulation and adhesive shall meet NFPA 90A requirements for flame spread and smoke generation.
 6. Unit casing shall be capable of withstanding 500-hour salt spray exposure per ASTM B117 (scribed specimen).
 7. Unit shall be designed in accordance with ISO 9001, and shall be manufactured in a facility registered by ISO 9001:2015.
 8. Roof curb shall be designed to conform to NRCA Standards.
 9. Unit shall be subjected to a completely automated run test on the assembly line. The data for each unit will be stored at the factory, and must be available upon request.
 10. Unit shall be designed in accordance with UL Standard 1995, including tested to withstand rain.
 11. Unit shall be constructed to prevent intrusion of snow and tested to prevent snow intrusion into the control box up to 40 mph.
 12. Unit shake tested to assurance level 1, ASTM D4169 to ensure shipping reliability.

- C. (23 81 19.13.C.) Delivery, Storage, and Handling:
 - 1. Unit shall be stored and handled per manufacturer's recommendations.
 - 2. Lifted by crane requires either shipping top panel or spreader bars.
 - 3. Unit shall only be stored or positioned in the upright position.
- D. (23 81 19.13.D.) Project Conditions:
 - 1. As specified in the contract.
- E. (23 81 19.13.E.) Operating Characteristics:
 - 1. Unit shall be capable of starting and running at 125°F (52°C) ambient outdoor temperature, meeting maximum load criteria of AHRI Standard 210/240 at ±10% voltage.
 - 2. Compressor with standard controls shall be capable of operation down to 35°F (2°C), ambient outdoor temperatures. Accessory winter start kit is necessary if mechanically cooling at ambient temperatures down to 25°F (-4°C).
 - 3. Unit shall discharge supply air vertically or horizontally as shown on contract drawings.
 - 4. Unit shall be factory configured for vertical supply and return configurations.
 - 5. Unit shall be field convertible from vertical to horizontal airflow on all models. No special kit required.
 - 6. Unit shall be capable of mixed operation: vertical supply with horizontal return or horizontal supply with vertical return.
- F. (23 81 19.13.F.) Electrical Requirements:
 - 1. Main power supply voltage, phase, and frequency must match those required by the manufacturer.
- G. (23 81 19.13.G.) Unit Cabinet:
 - 1. Unit cabinet shall be constructed of galvanized steel, and shall be bonderized and coated with a prepainted baked enamel finish on all externally exposed surfaces.
 - 2. Unit cabinet exterior paint shall be: film thickness, (dry) 0.003 in. minimum, gloss (per ASTM D523, 60°F/16°C): 60, Hardness: H-2H Pencil hardness.
 - 3. Evaporator fan compartment interior cabinet insulation shall conform to AHRI Standards 210/240 minimum exterior sweat criteria. Interior surfaces shall be insulated with a minimum 1/2 in. thick, 1 lb density, flexible fiberglass insulation, neoprene coated on the air side. Aluminum foil-faced fiberglass insulation shall be used in the gas heat compartment.
 - 4. Base of unit shall have a minimum of 4 locations for thru-the-base gas and electrical connections (factory-installed or field-installed), standard.
- 5. Base Rail:
 - a. Unit shall have base rails on a minimum of 2 sides.
 - b. Holes shall be provided in the base rails for rigging shackles to facilitate maneuvering and overhead rigging.
 - c. Holes shall be provided in the base rail for moving the rooftop by fork truck.
 - d. Base rail shall be a minimum of 16 gauge thickness.
- 6. Condensate Pan and Connections:
 - a. Shall be a sloped condensate drain pan made of a corrosion resistant material.
 - b. Shall comply with ASHRAE Standard 62.
 - c. Shall use a 3/4 in. 14 NPT drain connection, possible either through the bottom or side of the drain pan. Connection shall be made per manufacturer's recommendations.
- 7. Top Panel:
 - a. Shall be a single piece top panel on all sizes.
- 8. Gas Connections:
 - a. All gas piping connecting to unit gas valve shall enter the unit cabinet at a single location on side of unit (horizontal plane).
 - b. Thru-the-Base Capability
 - 1) Standard unit shall have a thru-the-base gas-line location using a raised, embossed portion of the unit basepan.
 - 2) Optional, factory approved, water-tight connection method must be used for thru-the-base gas connections.
 - 3) No basepan penetration, other than those authorized by the manufacturer, is permitted.
- 9. Electrical Connections:
 - a. All unit power wiring shall enter unit cabinet at a single, factory prepared, knockout location.
 - b. Thru-the-base capability.
 - 1) Standard unit shall have a thru-the-base electrical location(s) using a raised, embossed portion of the unit basepan.
 - 2) Optional, factory approved, water-tight connection method must be used for thru-the-base electrical connections.
 - 3) No basepan penetration, other than those authorized by the manufacturer, is permitted.
- 10. Component Access Panels (standard):
 - a. Cabinet panels shall be easily removable for servicing.
 - b. Unit shall have one factory installed, tool-less, removable, filter access panel.

- c. Panels covering control box, indoor fan, indoor fan motor, gas components (where applicable), and compressors shall have molded composite handles.
- d. Handles shall be UV modified, composite. They shall be permanently attached, and recessed into the panel.
- e. Screws on the vertical portion of all removable access panel shall engage into heat resistant, molded composite collars.
- f. Collars shall be removable and easily replaceable using manufacturer recommended parts.

H. (23 81 19.13.H.) Gas Heat:

1. General:

- a. Heat exchanger shall be an induced draft design. Positive pressure heat exchanger designs shall not be allowed.
- b. Shall incorporate a direct-spark ignition system and redundant main gas valve.
- c. Gas supply pressure at the inlet to the rooftop unit gas valve must match that required by the manufacturer.

2. The heat exchanger shall be controlled by an integrated gas controller (IGC) microprocessor.

- a. IGC board shall notify users of fault using an LED (light-emitting diode).
- b. The LED shall be visible without removing the control box access panel.
- c. IGC board shall contain algorithms that modify evaporator fan operation to prevent future cycling on high temperature limit switch.
- d. Unit shall be equipped with anti-cycle protection with one short cycle on unit flame rollout switch or 4 continuous short cycles on the high temperature limit switch. Fault indication shall be made using an LED.

3. Standard Heat Exchanger Construction:

- a. Heat exchanger shall be of the tubular-section type constructed of a minimum of 20-gauge steel coated with a nominal 1.2 mil aluminum-silicone alloy for corrosion resistance.
- b. Burners shall be of the in-shot type constructed of aluminum-coated steel.
- c. Burners shall incorporate orifices for rated heat output up to 2000 ft (610 m) elevation. Additional accessory kits may be required for applications above 2000 ft (610 m) elevation, depending on local gas supply conditions.
- d. Each heat exchanger tube shall contain multiple dimples for increased heating effectiveness.

4. Optional Stainless Steel Heat Exchanger Construction:

- a. Use energy saving, direct-spark ignition system.
- b. Use a redundant main gas valve.
- c. Burners shall be of the in-shot type constructed of aluminum-coated steel.
- d. All gas piping shall enter the unit cabinet at a single location on side of unit (horizontal plane).
- e. The optional stainless steel heat exchanger shall be of the tubular-section type, constructed of a minimum of 20-gauge type 409 stainless steel.
- f. Type 409 stainless steel shall be used in heat exchanger tubes and vestibule plate.
- g. Complete stainless steel heat exchanger allows for greater application flexibility.

5. Optional Low NOx Heat Exchanger Construction:

- a. Low NOx reduction shall be provided to reduce nitrous oxide emissions to meet California's Air Quality Management District (SCAQMD) low-NOx emissions requirement of 40 nanograms per joule or less.
- b. Primary tubes and vestibule plates on low NOx units shall be 409 stainless steel. Other components shall be aluminized steel.

6. Induced Draft Combustion Motor and Blower:

- a. Shall be a direct-drive, single inlet, forward-curved centrifugal type.
- b. Shall be made from steel with a corrosion resistant finish.
- c. Shall have permanently lubricated sealed bearings.
- d. Shall have inherent thermal overload protection.
- e. Shall have an automatic reset feature.

I. (23 81 19.13.I.) Coils:

1. Standard Aluminum Fin-Copper Tube Coils:

- a. Standard evaporator and condenser coils shall have aluminum lanced plate fins mechanically bonded to seamless internally grooved copper tubes with all joints brazed.
- b. Evaporator coils shall be leak tested to 150 psig, pressure tested to 450 psig, and qualified to UL 1995 burst test at 1775 psig.
- c. Condenser coils shall be leak tested to 150 psig, pressure tested to 650 psig, and qualified to UL 1995 burst test at 1980 psig.

2. Optional Pre-coated Aluminum-Fin Condenser Coils (3-phase models only):

- a. Shall have a durable epoxy-phenolic coating to provide protection in mildly corrosive coastal environments.

- b. Coating shall be applied to the aluminum fin stock prior to the fin stamping process to create an inert barrier between the aluminum fin and copper tube.
 - c. Epoxy-phenolic barrier shall minimize galvanic action between dissimilar metals.
 - d. Corrosion durability of fin stock shall be confirmed through testing to be no less than 1000 hours salt spray per ASTM B117-90.
 - e. Corrosion durability of fin stock shall be confirmed through testing to have no visible corrosion after 48 hour immersion in a room temperature solution of 5% salt, 1% acetic acid.
 - f. Fin stock coating shall pass 2000 hours of the following: one week exposure in the prohesion chamber followed by one week of accelerated ultraviolet light testing. Prohesion chamber: the solution shall contain 3.5% sodium chloride and 0.35% ammonium sulfate. The exposure cycle is one hour of salt fog application at ambient followed by one hour drying at 95°F (35°C).
3. Optional Copper-Fin Evaporator and Condenser Coils (3-phase models only):
- a. Shall be constructed of copper fins mechanically bonded to copper tubes and copper tube sheets.
 - b. Galvanized steel tube sheets shall not be acceptable.
 - c. A polymer strip shall prevent coil assembly from contacting the sheet metal coil pan to minimize potential for galvanic corrosion between coil and pan.
4. Optional E-coated Aluminum-Fin Evaporator and Condenser Coils (3-phase models only):
- a. Shall have a flexible epoxy polymer coating uniformly applied to all coil surface areas without material bridging between fins.
 - b. Coating process shall ensure complete coil encapsulation of tubes, fins and headers.
 - c. Color shall be high gloss black with gloss per ASTM D523-89.
 - d. Uniform dry film thickness from 0.8 to 1.2 mil on all surface areas including fin edges.
 - e. Superior hardness characteristics of 2H per ASTM D3363-92A and cross-hatch adhesion of 4B-5B per ASTM D3359-93.
 - f. Impact resistance shall be up to 160 in.-lb (ASTM D2794-93).
 - g. Humidity and water immersion resistance shall be up to minimum 1000 and 250 hours respectively (ASTM D2247-92 and ASTM D870-92).
- h. Corrosion durability shall be confirmed through testing to be no less than 1000 hours salt spray per ASTM B117-90.
- J. (23 81 19.13.J.) Refrigerant Components:
- 1. Refrigerant circuit shall include the following control, safety, and maintenance features:
 - a. TXV metering system on all models shall include a multiple feed distribution system that optimizes coil performance.
 - b. Refrigerant filter drier — Solid core design.
 - c. Service gauge connections on suction and discharge lines.
 - d. Pressure gauge access through a specially designed access port in the top panel of the unit.
 - 2. There shall be gauge line access port in the skin of the rooftop, covered by a black, removable plug.
 - a. The plug shall be easy to remove and replace.
 - b. When the plug is removed, the gauge access port shall enable maintenance personnel to route their pressure gauge lines.
 - c. This gauge access port shall facilitate correct and accurate condenser pressure readings by enabling the reading with the compressor access panel on.
 - d. The plug shall be made of a leak proof, UV-resistant, composite material.
 - 3. Compressors:
 - a. Unit shall use fully hermetic, 2-stage scroll compressor on a single refrigeration circuit.
 - b. Compressor motors shall be cooled by refrigerant gas passing through motor windings.
 - c. Compressors shall be internally protected from high discharge temperature conditions.
 - d. Compressors shall be protected from an over-temperature and over-ampereage conditions by an internal, motor overload device.
 - e. Compressor shall be factory mounted on rubber grommets.
 - f. Compressor motors shall have internal line break thermal, current overload and high pressure differential protection.
 - g. Crankcase heaters shall not be required for normal operating range, unless required by compressor manufacturer due to refrigerant charge limits.
- K. (23 81 19.13.K.) Filter Section:
- 1. Filters access is specified in the unit cabinet section of this specification.
 - 2. Filters shall be held in place by a pivoting filter tray, facilitating easy removal and installation.

3. Shall consist of factory installed, low velocity, throw-away 2 in. thick fiberglass filters.
 4. Filters shall be standard, commercially available sizes.
 5. Only one size filter per unit is allowed.
- L. (23 81 19.13.L.) Evaporator Fan and Motor with EcoBlue™ Technology:
1. Direct Drive Evaporator Fan Motor:
 - a. Shall be a ECM motor design.
 - b. Shall have permanently lubricated bearings.
 - c. Shall have inherent automatic-reset thermal overload protection.
 - d. Shall have slow ramp up to speed capabilities.
 - e. Shall require no fan/motor belts for operation, adjustments and or initial fan speed set up.
 - f. Fan DC voltage set up on Unit Control Board can eliminate the need of removal of blower access door, required on conventional belt drive systems.
 - g. Shall be internally protected from electrical phase reversal and loss.
 2. Evaporator Fan:
 - a. Shall be easily set with selection switch and adjustment pot on unit control board or through SystemVu™ controller.
 - b. On all sizes 04-06 which have 2-stage cooling capacity control, the indoor fan speed is automatically controlled to meet the AHRI performance requirement with 75% low fan speed and 100% at full fan speed operation
 - c. Blower fan shall be a Vane Axial fan design with 75% less moving parts than a conventional belt drive system.
 - d. Shall be constructed of a cast aluminum stator and high impact composite material on rotor and air inlet casing.
 - e. Shall be a patented / pending design with a corrosion resistant material and dynamically balanced.
 - f. Shall have slow ramp up to speed capabilities to help reduce sound and comfort issues typically associated with single speed belt drive systems.
 - g. Shall be a slide out design with 2 screw removal.
 3. Shall include an easily accessible Unit Control Board to conveniently and safely provide connection points for vital control functions such as: smoke detectors, phase monitor, gas controller, economizer, thermostat, DDC control options, and low and high pressure switches. Controller shall also provide an intuitive means to adjust the indoor fan speed through a simple switch and pot adjustment design.
- M. (23 81 19.13.M.) Condenser Fans and Motors:
1. Condenser Fan Motors:
 - a. Shall be a totally enclosed motor.
 - b. Shall use permanently lubricated bearings.
 - c. Shall have inherent thermal overload protection with an automatic reset feature.
 - d. Shall use a shaft-down design on all sizes.
 2. Condenser Fans:
 - a. Shall be a direct-driven propeller type fan constructed of high impact composite material.
 - b. Shall have high impact composite blades completely formed into one piece without blade fasteners or connectors and shall be dynamically balanced.
- N. (23 81 19.13.N.) Special Features Options and Accessories:
1. Integrated EconomizerONE and EconoMiSer® 2 Low Leak Rate Models. (Factory installed on 3-phase models only. Field-installed on all 3 and 1-phase models.)
 - a. Integrated, gear driven opposing modulating blade design type capable of simultaneous economizer and compressor operation.
 - b. Independent modules for vertical or horizontal return configuration shall be available. Vertical return modules shall be available as a factory installed option.
 - c. Damper blades shall be galvanized steel with composite gears. Plastic or composite blades on intake or return shall not be acceptable.
 - d. Shall include all hardware and controls to provide free cooling with outdoor air when temperature and/or humidity are below setpoints.
 - e. Shall be equipped with gear driven dampers for both the outdoor ventilation air and the return air for positive air stream control.
 - f. Standard leak rate shall be equipped with dampers not to exceed 2% leakage at 1 in. wg pressure differential.
 - g. Economizer controller on EconomizerONE models shall be Siemens POL224 that provides:
 - 1) Combined minimum and DCV maximum damper position potentiometers with compressor staging relay.
 - 2) Functions with solid-state analog enthalpy or dry bulb changeover control sensing.
 - 3) LED indication for free cooling, sensor, and damper operation.
 - 4) One-line LCD interface screen for setup, configuration and troubleshooting.

- 5) On-board Fault Detection and Diagnostics (FDD) that senses and alerts when the economizer is not operating properly, per California Title 24, ASHRAE 90.1 and IECC¹.
- 6) Sensor failure loss of communication identification.
- 7) Capabilities for use with multiple-speed or single speed indoor fan systems.
- 8) Digital sensors: Dry bulb and Enthalpy.
- h. Economizer controller on EconoMi\$er 2 models with RTU Open or SystemVu controllers shall be a 4 to 20mA design controlled directly by the controller. RTU Open and SystemVu meet California Title 24, ASHRAE 90.1 and IECC Fault Detection and Diagnostic (FDD) requirements.
- i. Shall be capable of introducing up to 100% outdoor air.
- j. Shall be equipped with a barometric relief damper capable of relieving up to 100% return air and contain seals that meet ASHRAE 90.1 requirements.
- k. Shall be designed to close damper(s) during loss-of-power situations with spring return built into motor.
- l. Dry bulb outdoor air temperature sensor shall be provided as standard. Enthalpy sensor is also available on factory-installed economizers only. Outdoor air sensor setpoint shall be adjustable and shall range from 40°F to 100°F (4°C to 38°C). Additional sensor options shall be available as accessories.
- m. The economizer controller shall also provide control of an accessory power exhaust unit function. Factory set at 100%, with a range of 0% to 100%.
- n. The economizer shall maintain minimum airflow into the building during occupied period and provide design ventilation rate for full occupancy.
- o. Dampers shall be completely closed when the unit is in the unoccupied mode.
- p. Economizer controller shall accept a 0 to 10 vdc CO₂ sensor input for IAQ/DCV control. In this mode, dampers shall modulate the outdoor air damper to provide ventilation based on the sensor input.
- q. Compressor lockout temperature on POL224 control is adjustable from -45°F to 80°F (-43°C to 26°C), set at a factory default of 32°F (0°C).
- r. Actuator shall be direct coupled to economizer gear. No linkage arms or control rods shall be acceptable.
- s. Contains LED indication for free cooling, sensor, and damper operation.
2. Integrated EconomizerONE and EconoMi\$er 2 Ultra Low Leak Rate Models. (Factory installed on 3-phase models only. Field installed on all 3 and 1-phase models.)
 - a. Integrated, gear driven opposing modulating blade design type capable of simultaneous economizer and compressor operation.
 - b. Independent modules for vertical or horizontal return configuration shall be available. Vertical return modules shall be available as a factory installed option.
 - c. Damper blades shall be galvanized steel with composite gears. Plastic or composite blades on intake or return shall not be acceptable.
 - d. Shall include all hardware and controls to provide free cooling with outdoor air when temperature and/or humidity are below set-points.
 - e. Shall be equipped with gear driven dampers for both the outdoor ventilation air and the return air for positive air stream control.
 - f. Ultra Low Leak design meets California Title 24 section 140.4 and ASHRAE 90.1 requirements for 4 cfm per sq. ft. on the outside air dampers and 10 cfm per sq. ft. on the return dampers.
 - g. Economizer controller on EconomizerONE models shall be the Siemens POL224 that provides:
 - 1) One-line LCD interface screen for setup, configuration, and troubleshooting.
 - 2) On-board Fault Detection and Diagnostics (FDD) that senses and alerts when the economizer is not operating properly, per California Title 24, ASHRAE 90.1 and IECC¹.
 - 3) Sensor failure loss of communication identification.
 - 4) Capabilities for use with multiple-speed indoor fan systems.
 - 5) Digital sensors: Dry bulb and Enthalpy.
 - h. Economizer controller on EconoMi\$er 2 models with RTU Open or SystemVu™ controls shall be a 4-20mA design controlled directly by the controller. RTU Open and SystemVu meet California Title 24, ASHRAE 90.1 and IECC Fault Detection and Diagnostic (FDD) requirements.
 - i. Shall be capable of introducing up to 100% outdoor air.
 - j. Shall be equipped with a barometric relief damper capable of relieving up to 100% return air and contain seals that meet ASHRAE 90.1 requirements.

1. Third-party trademarks and logos are the property of their respective owners.

- k. Shall be designed to close damper(s) during loss-of-power situations with spring return built into motor.
 - l. Dry bulb outdoor air temperature sensor shall be provided as standard. Enthalpy sensor is also available on factory-installed economizers only. Outdoor air sensor setpoint shall be adjustable and shall range from 40°F to 100° F (4°C to 38°C). Additional sensor options shall be available as accessories.
 - m. The economizer controller shall also provide control of an accessory power exhaust unit function. Factory set at 100%, with a range of 0% to 100%.
 - n. The economizer shall maintain minimum airflow into the building during occupied period and provide design ventilation rate for full occupancy.
 - o. Dampers shall be completely closed when the unit is in the unoccupied mode.
 - p. Economizer controller shall accept a 0 to 10 vdc CO₂ sensor input for IAQ/DCV control. In this mode, dampers shall modulate the outdoor air damper to provide ventilation based on the sensor input.
 - q. Compressor lockout temperature on POL224 control is adjustable from -45°F to 80°F (-43°C to 26°C), set at a factory default of 32°F (0°C).
 - r. Actuator shall be direct coupled to economizer gear. No linkage arms or control rods shall be acceptable.
 - s. Contains LED indication for free cooling, sensor, and damper operation.
3. Wi-Fi/WLAN Stick for EconomizerONE POL224 (field-installed):
This item allows use of the Siemens Climatix™1 mobile application.
4. Two-Position Damper (field-installed only):
- a. Damper shall be a Two-Position Damper. Damper travel shall be from the full closed position to the field adjustable %-open setpoint.
 - b. Damper shall include adjustable damper travel from 25% to 100% (full open).
 - c. Damper shall include single or dual blade, gear driven dampers and actuator motor.
 - d. Actuator shall be direct coupled to damper gear. No linkage arms or control rods shall be acceptable.
 - e. Damper will admit up to 100% outdoor air for applicable rooftop units.
 - f. Damper shall close upon indoor (evaporator) fan shutoff and/or loss of power.
- g. The damper actuator shall plug into the rooftop unit's wiring harness plug. No hard wiring shall be required.
 - h. Outside air hood shall include aluminum water entrainment filter.
5. Manual Damper (field-installed only):
- a. Manual damper package shall consist of damper, air inlet screen, and rain hood which can be preset to admit up to 25% or 50% outdoor air for year round ventilation.
6. Humidi-MiZer® Adaptive Dehumidification System (3-phase models only):
- a. The Humidi-MiZer Adaptive Dehumidification System shall be factory installed and shall provide greater dehumidification of the occupied space by 2 modes of dehumidification operations in addition to its normal design cooling mode:
 - 1) Subcooling mode further sub cools the hot liquid refrigerant leaving the condenser coil when both temperature and humidity in the space are not satisfied.
 - 2) Hot gas reheat mode shall mix a portion of the hot gas from the discharge of the compressor with the hot liquid refrigerant leaving the condenser coil to create a 2-phase heat transfer in the system, resulting in a neutral leaving air temperature when only humidity in the space is not satisfied.
 - 3) Includes low ambient controller.
7. Low Ambient Control Package:
- a. Controller shall control coil head pressure by condenser fan speed modulation or condenser fan cycling and wind baffles.
 - b. Shall consist of solid-state control and condenser coil temperature sensor to maintain condensing temperature between 90°F (32°C) and 110°F (43°C) at outdoor ambient temperatures down to -20°F (-29°C).
8. Propane Conversion Kit:
- a. Package shall contain all the necessary hardware and instructions to convert a standard natural gas unit for use with liquefied propane, up to 2000 ft (610 m) elevation.
 - b. Additional accessory kits may be required for applications above 2000 ft (610 m) elevation.
9. Flue Shield:
- a. Flue shield shall provide protection from the hot sides of the gas flue hood.
10. Condenser Coil Hail Guard Assembly (Factory-installed on 3-phase models only. Field-installed on all 3 and 1-phase models.)
- a. Shall protect against damage from hail.
 - b. Shall be either hood style or louvered.

1. Third-party trademarks and logos are the property of their respective owners.

11. Unit-Mounted, Non-Fused Disconnect Switch (Available on units with MOCPs of 80 amps or less):
 - a. Switch shall be factory installed, internally mounted.
 - b. National Electric Code (NEC) and UL approved non-fused switch shall provide unit power shutoff.
 - c. Shall be accessible from outside the unit.
 - d. Shall provide local shutdown and lockout capability.
 - e. Sized only for the unit as ordered from the factory. Does not accommodate field-installed devices.
 12. HACR Breaker:
 - a. These manual reset devices provide overload and short circuit protection for the unit. Factory wired and mounted with the units, with access cover to help provide environmental protection. On 575V applications, HACR breaker can only be used with WYE power distribution systems. Use on Delta power distribution systems is prohibited.
 - b. Sized only for the unit as ordered from the factory. Does not accommodate field-installed devices.
 13. Convenience Outlet:
 - a. Powered Convenience Outlet. (3-phase models only)
 - 1) Outlet shall be powered from main line power to the rooftop unit.
 - 2) Outlet shall be powered from line side or load side of disconnect by installing contractor, as required by code. If outlet is powered from load side of disconnect, unit electrical ratings shall be UL certified and rated for additional outlet amperage.
 - 3) Outlet shall be factory-installed and internally mounted with easily accessible 115-v female receptacle.
 - 4) Outlet shall include 15 amp GFI receptacles with independent fuse protection.
 - 5) Voltage required to operate convenience outlet shall be provided by a factory installed step-down transformer.
 - 6) Outlet shall be accessible from outside the unit.
 - 7) Outlet shall include a field installed “Wet in Use” cover.
 - b. Factory-Installed Non-Powered Convenience Outlet.
 - 1) Outlet shall be powered from a separate 115/120-v power source.
 - 2) A transformer shall not be included.
 - 3) Outlet shall be factory-installed and internally mounted with easily accessible 115-v female receptacle.
 - 4) Outlet shall include 15 amp GFI receptacles with independent fuse protection.
 - 5) Outlet shall be accessible from outside the unit.
 - 6) Outlet shall include a field installed “Wet in Use” cover.
 - c. Field-Installed Non-Powered Convenience Outlet.
 - 1) Outlet shall be powered from a separate 115/120-v power source.
 - 2) A transformer shall not be included.
 - 3) Outlet shall be field-installed and internally mounted with easily accessible 115-v female receptacle.
 - 4) Outlet shall include 20 amp GFI receptacles. This kit provides a flexible installation method which allows code compliance for height requirements of the GFCI outlet from the finished roof surface as well as the capability to relocate the outlet to a more convenient location.
 - 5) Outlet shall be accessible from outside the unit.
 - 6) Outlet shall include a field installed “Wet in Use” cover.
14. Flue Discharge Deflector:
 - a. Flue discharge deflector shall direct unit exhaust vertically instead of horizontally.
 - b. Deflector shall be defined as a “natural draft” device by the National Fuel and Gas (NFG) code.
15. Thru-the-Base Connectors:
 - a. Kits shall provide connectors to permit gas and electrical connections to be brought to the unit through the unit basepan.
 - b. Minimum of 4 connection locations per unit.
16. Propeller Power Exhaust:
 - a. Power exhaust shall be used in conjunction with an integrated economizer.
 - b. Independent modules for vertical or horizontal return configurations shall be available.
 - c. Horizontal power exhaust is shall be mounted in return ductwork.
 - d. Power exhaust shall be controlled by economizer controller operation. Exhaust fans shall be energized when dampers open past the 0 to 100% adjustable setpoint on the economizer control.
17. Roof Curbs (Vertical):
 - a. Full perimeter roof curb with exhaust capability providing separate air streams for

- energy recovery from the exhaust air without supply air contamination.
 - b. Formed galvanized steel with wood nailer strip and shall be capable of supporting entire unit weight.
 - c. Permits installation and securing of ductwork to curb prior to mounting unit on the curb.
18. High Altitude Gas Conversion Kit:
- a. Package shall contain all the necessary hardware and instructions to convert a standard natural gas unit to operate from 2000 to 7000 ft (610 to 2134 m) elevation with natural gas or from 0 to 7000 ft (0 to 2134 m) elevation with liquefied propane.
19. Outdoor Air Enthalpy Sensor:
- a. The outdoor air enthalpy sensor shall be used to provide single enthalpy control. When used in conjunction with a return air enthalpy sensor, the unit will provide differential enthalpy control. The sensor allows the unit to determine if outside air is suitable for free cooling.
20. Return Air Enthalpy Sensor:
- a. The return air enthalpy sensor shall be used in conjunction with an outdoor air enthalpy sensor to provide differential enthalpy control.
21. Indoor Air Quality (CO₂) Sensor:
- a. Shall be able to provide demand ventilation indoor air quality (IAQ) control.
 - b. The IAQ sensor shall be available in duct mount, wall mount, or wall mount with LED display. The setpoint shall have adjustment capability.
22. Smoke Detectors (factory-installed only):
- a. Shall be a 4-wire controller and detector.
 - b. Shall be environmental compensated with differential sensing for reliable, stable, and drift-free sensitivity.
 - c. Shall use magnet-activated test/reset sensor switches.
 - d. Shall have tool-less connection terminal access.
 - e. Shall have a recessed momentary switch for testing and resetting the detector.
 - f. Controller shall include:
 - 1) One set of normally open alarm initiation contacts for connection to an initiating device circuit on a fire alarm control panel.
 - 2) Two Form-C auxiliary alarm relays for interface with rooftop unit or other equipment.
- 3) One Form-C supervision (trouble) relay to control the operation of the Trouble LED on a remote test/reset station.
 - 4) Capable of direct connection to 2 individual detector modules.
 - 5) Can be wired to up to 14 other duct smoke detectors for multiple fan shut-down applications.
23. Winter Start Kit:
- a. Shall contain a bypass device around the low pressure switch.
 - b. Shall be required when mechanical cooling is required down to 25°F (-4°C).
 - c. Shall not be required to operate on an economizer when below an outdoor ambient of 35°F (2°C).
24. Time Guard:
- a. Shall prevent compressor short-cycling by providing a 5 minute delay (±2 minutes) before restarting a compressor after shut-down for any reason.
 - b. One device shall be required per compressor.
25. Hinged Access Panels:
- a. Shall provide easy access through integrated quarter turn latches.
 - b. Shall be on major panels of: filter, control box, fan motor, and compressor.
26. Condensate Overflow Switch:
- a. This sensor and related controller monitors the condensate level in the drain pan and shuts down compression operation when overflow conditions occur. It includes:
 - 1) Indicator light — solid red (more than 10 seconds on water contact — compressors disabled), blinking red (sensor disconnected).
 - 2) 10 second delay to break — eliminates nuisance trips from splashing or waves in pan (sensor needs 10 seconds of constant water contact before tripping).
 - 3) Disables the compressor(s) operation when condensate plug is detected, but still allows fans to run for economizer.
27. Foil Faced Insulation:
- a. Throughout unit cabinet air stream, non-fibrous and cleanable foil faced insulation is used.
28. MERV-13 Return Air Filters:
- a. Factory option to upgrade standard unit filters to MERV-13 filters.

29. Phase Monitor Control:

- a. Shall monitor the sequence of 3-phase electrical system to provide a phase reversal protection.
- b. Shall monitor the 3-phase voltage inputs to provide a phase loss protection for the 3-phase device.
- c. Will work on either a Delta or Wye power connection.

30. Horn/Strobe Annunciator:

- a. Provides an audible/visual signaling device for use with factory-installed option or field installed accessory smoke detectors.
 - 1) Requires installation of a field-supplied 24-v transformer suitable for 4.2 VA (AC) or 3.0 VA (DC) per horn/strobe accessory.
 - 2) Requires field-supplied electrical box, North American 1-gang box, 2 in. (51 mm) x 4 in. (102 mm).
 - 3) Shall have a clear colored lens.

Note about this specification:

This specification is in the “Masterformat” as published by the Construction Specification Institute. Please feel free to copy this specification directly into your building spec.



High Efficiency Cooling Only/Electric Heat Packaged Rooftop

HVAC Guide Specifications

Size Range: **3 to 5 Nominal Tons**

Carrier Model Number: **50GC**04-06**

Part 1 — (23 06 80) Schedules for Decentralized HVAC Equipment

1.01 (23 06 80.13) Decentralized Unitary HVAC Equipment Schedule:

- A. (23 06 80.13.A.) Rooftop Unit (RTU) Schedule:
 1. Schedule is per the project specification requirements.

Part 2 — (23 07 16) HVAC Equipment Insulation

2.01 (23 07 16.13) Decentralized, Rooftop Units:

- A. (23 07 16.13.A.) Evaporator Fan Compartment:
 1. Interior cabinet surfaces shall be insulated with a minimum 1/2 in. thick, minimum 1-1/2 lb density, flexible fiberglass insulation bonded with a phenolic binder, neoprene coated on the air side.
 2. Insulation and adhesive shall meet NFPA 90A requirements for flame spread and smoke generation.
- B. (23 07 16.13.B.) Electric Heat Compartment:
 1. Aluminum foil-faced fiberglass insulation shall be used.
 2. Insulation and adhesive shall meet NFPA 90A requirements for flame spread and smoke generation.

Part 3 — (23 09 13) Instrumentation and control devices for HVAC

3.01 (23 09 13.23) Sensors and Transmitters:

- A. (23 09 13.23.A.) Thermostats:
 1. Thermostat must:
 - a. energize both “W” and “G” when calling for heat.
 - b. have capability to energize 2 stages of cooling, and 2 different stages of heating.
 - c. include capability for occupancy scheduling.

Part 4 — (23 09 23) Direct Digital Control System for HVAC

4.01 (23 09 23.13) Decentralized, Rooftop Units:

- A. (23 09 23.13.A.) SystemVu™ intelligent integrated Direct Digital Control (DDC) shall provide:
 1. Integrated unit operation for comfort cooling, heating ventilation as well as all monitoring, recording and reporting capabilities. Controller

shall also provide diagnostics and alarms of abnormal unit operation through the controller. Controller shall have an intuitive user display and be able to be used in a standalone operation or via building automation system (BAS).

2. Quick Unit Status LEDs of: Run — meaning all systems are go, ALERT — that indicates there is currently a non-critical issue with the unit, like filters need to be replaced and FAULT — that indicates the unit has a critical issue and will possibly shut down.
3. Six large navigation keys for easy access. Navigation keys shall consist of: TEST, BACK, ENTER, and MENU along with UP and DOWN arrows.
4. Full back lit user display with 4 line by 30 character text capabilities. Display menu shall be designed to provide guided major menus and sub menus main menus provided below:
 - a. Shutdown Unit
 - b. Run Status
 - c. Settings
 - d. Alerts/Faults
 - e. Service
 - f. Inputs
 - g. Outputs
 - h. USB
5. The capability for standalone operation with conventional thermostat/sensor or use with building automation systems (BAS) of Carrier i-Vu®, BACnet™1 and Carrier Comfort Network® (CCN) systems. No special modules or boards are required for these capabilities. Has the capability to work with Equipment Touch™ and System Touch™ devices and ZS Sensors.
6. The ability to read refrigerant pressures at display or via BAS network of; Discharge Pressure and Suction Pressure. The need for traditional refrigerant gauges is not required.
7. USB Data Port for flash drive interaction. This will allow the transfer of data for uploads, downloads, perform software upgrades, back-up and restore data and file transfer data such as component number of starts and run hours.
8. Reverse Rotation Protection of compressors if field 3-phase wiring is misapplied.
9. Provide Service Capabilities of:
 - a. Auto run test
 - b. Manual run test
 - c. Component run hours and starts
 - d. Commissioning reports
 - e. Data logging
 - f. Alarm history

1. Third-party trademarks and logos are the property of their respective owners.

10. Economizer control and diagnostics. Set up economizer operation, receive feedback from actuator. Also meets the most recent California Title 24, ASHRAE 90.1 and IECC Fault Detection and Diagnostic (FDD) requirements.
 11. Unit cooling operation down to 35°F (2°C).
 12. Controller shall have easy access connections around the controller perimeter area and consist of Mate-N-Lok¹, terminal block and RJ style modular jack connections.
 13. 365 day real time clock, 20 holiday schedules along with occupied and unoccupied scheduling.
 14. Auto-Recognition for easy installation and commissioning of devices like economizers, space sensors etc.
 15. A 5°F (3°C) temperature difference between cooling and heating setpoints to meet the latest ASHRAE 90.1 Energy Standard.
 16. Contain return air sensor, supply air sensor and outdoor air sensor to help monitor and provide data for the unit comfort operation, diagnostic and alarms.
 17. Use of Carrier's field accessory hand-held Navigator™ display, Equipment Touch and System Touch devices.
 18. Units with the factory-installed Humidi-MiZer® system option are capable of providing multiple modes of improved dehumidification as a variation of the normal cooling cycle.
 19. Supply Air Tempering control operates the gas or electric heat to maintain a minimum supply air temperature during conditions where very cold outdoor air causes the supply air temperature to fall below the configured Supply Air Tempering Setpoint. This occurs during periods where DCV is active and increasing the amount of outdoor air or in cases where the system is operating at very low airflow and the calculated economizer position has increased to maintain a constant ventilation rate.
 20. Demand limiting in SystemVu™ is achieved through setpoint expansion. The systems heating and cooling setpoints are expanded in steps or levels. The degree to which the setpoints may be expanded is defined by the 6 demand level offsets and the 2 commanded demand limit levels.
 21. 3-year limited part warranty.
- B. (23 09 23.13.B.) RTU Open Protocol, Direct Digital Controller:
 1. Shall be ASHRAE 62 compliant.
 2. Shall accept 18-30 vac, 50-60 Hz, and consumer 15VA or less power.
 3. Shall have an operating temperature range from -40°F (-40°C) to 130°F (54°C), 10% to 90% RH (non-condensing).
 4. Shall include built-in protocol for BACnet™1 (MS/TP and PTP modes), Modbus®1 (RTU and ASCII), Johnson Controls®1 N2 and LonWorks®1. LonWorks Echelon processor required for all Lon applications shall be contained in separate communication board.
 5. Shall allow access of up to 62 network variables (SNVT). Shall be compatible with all open controllers.
 6. Baud rate controller shall be selectable using a DIP switch.
 7. Shall have an LED display independently showing the status of serial communication, running, errors, power, all digital outputs, and all analog inputs.
 8. Shall accept the following inputs: space temperature, setpoint adjustment, outdoor air temperature, indoor air quality, outdoor air quality, compressor lock-out, fire shutdown, enthalpy switch, and fan status/filter status/humidity/remote occupancy.
 9. Shall provide the following outputs: economizer, fan, cooling stage 1, cooling stage 2, heat stage 1, heat stage 2, exhaust, reversing valve/high fan speed.
 10. Shall have built-in surge protection circuitry through solid-state polyswitches. Polyswitches shall be used on incoming power and network connections. Polyswitches will return to normal when the "trip" condition clears.
 11. Shall have a battery back-up capable of a minimum of 10,000 hours of data and time clock retention during power outages.
 12. Shall have built-in support for Carrier technician tool.
 13. Shall include an RS-485 protocol communication port, an access port for connection of either a computer or a Carrier technician tool, an RS-485 port for network communication to intelligent space sensors and displays, and a port to connect an optional LonWorks communications card.
 14. Software upgrades will be accomplished by either local or remote download. No software upgrades through chip replacements are allowed.

1. Third-party trademarks and logos are the property of their respective owners.

Part 5 — (23 09 33) Electric and Electronic Control System for HVAC

6.01 (23 09 33.13) Decentralized, Rooftop Units:

A. (23 09 33.13.A.) General:

1. Shall be complete with self-contained low-voltage control circuit protected by a resettable circuit breaker on the 24-v transformer side. Transformer shall have 75VA capability.
2. Shall utilize color-coded wiring.
3. Shall include a Unit Control Board to conveniently and safely provide connection points for vital control functions such as: smoke detectors, phase monitor, economizer, thermostat, DDC control options, and low and high pressure switches. Controller shall also provide an intuitive means to adjust the indoor fan speed through a simple switch and pot adjustment design.
4. Unit shall include a minimum of one 8-pin screw terminal connection board for connection of control wiring.

B. (23 09 33.13.B.) Safeties:

1. Compressor over-temperature, over-current. High internal pressure differential.
2. Low Pressure Switch.
 - a. Low pressure switch shall use different color wire than the high pressure switch. The purpose is to assist the installer and service technician to correctly wire and or trouble-shoot the rooftop unit.
3. High Pressure Switch.
 - a. High pressure switch shall use different color wire than the low pressure switch. The purpose is to assist the installer and service technician to correctly wire and or trouble-shoot the rooftop unit.
4. Automatic Reset, Motor Thermal Overload Protector.

Part 6 — (23 09 93) Sequence of Operations for HVAC Controls

6.01 (23 09 93.13) Decentralized, Rooftop Units:

A. (23 09 93.13.A.) INSERT SEQUENCE OF OPERATION

Part 7 — (23 40 13) Panel Air Filters

7.01 (23 40 13.13) Decentralized, Rooftop Units:

A. (23 40 13.13.A.) Standard Filter Section:

1. Shall consist of factory installed, low velocity, disposable 2 in. thick fiberglass filters of commercially available sizes.
2. Unit shall use only one filter size. Multiple sizes are not acceptable.
3. Filters shall be accessible through an access panel with “no-tool” removal as described in

the unit cabinet section of this specification (23 81 19.13.G).

Part 8 — (23 81 19) Self-Contained Air Conditioners

8.01 (23 81 19.13) Small-Capacity Self-Contained Air Conditioners:

A. (23 81 19.13.A.) General:

1. Outdoor, rooftop mounted, electrically controlled, heating and cooling unit utilizing a fully hermetic scroll compressor(s) for cooling duty and optional electric heat for heating duty.
2. Factory assembled, single-piece heating and cooling rooftop unit. Contained within the unit enclosure shall be all factory wiring, piping, controls, and special features required prior to field start-up.
3. Unit shall use Puron® (R-410A) refrigerant.
4. Unit shall be installed in accordance with the manufacturer's instructions.
5. Unit must be selected and installed in compliance with local, state, and federal codes.

B. (23 81 19.13.B.) Quality Assurance:

1. Unit meets and exceeds ASHRAE 90.1 minimum efficiency requirements.
2. Unit shall be rated in accordance with AHRI Standards 210/240.
3. Unit shall be designed to conform to ASHRAE 15.
4. Unit shall be UL-tested and certified in accordance with ANSI Z21.47 Standards and UL-listed and certified under Canadian standards as a total package for safety requirements.
5. Insulation and adhesive shall meet NFPA 90A requirements for flame spread and smoke generation.
6. Unit casing shall be capable of withstanding 500 hour salt spray exposure per ASTM B117 (scribed specimen).
7. Unit shall be designed in accordance with ISO 9001, and shall be manufactured in a facility registered by ISO 9001:2015.
8. Roof curb shall be designed to conform to NRCA Standards.
9. Unit shall be subjected to a completely automated run test on the assembly line. The data for each unit will be stored at the factory, and must be available upon request.
10. Unit shall be designed in accordance with UL Standard 1995, including tested to withstand rain.
11. Unit shall be constructed to prevent intrusion of snow and tested to prevent snow intrusion into the control box up to 40 mph.
12. Unit shake tested to assurance level 1, ASTM D4169 to ensure shipping reliability.

- C. (23 81 19.13.C.) Delivery, Storage, and Handling:
 - 1. Unit shall be stored and handled per manufacturer's recommendations.
 - 2. Lifted by crane requires either shipping top panel or spreader bars.
 - 3. Unit shall only be stored or positioned in the upright position.
- D. (23 81 19.13.D.) Project Conditions:
 - 1. As specified in the contract.
- E. (23 81 19.13.E.) Operating Characteristics:
 - 1. Unit shall be capable of starting and running at 125°F (52°C) ambient outdoor temperature, meeting maximum load criteria of AHRI Standard 210/240 at ±10% voltage.
 - 2. Compressor with standard controls shall be capable of operation down to 35°F (2°C), ambient outdoor temperatures. Accessory winter start kit is necessary if mechanically cooling at ambient temperatures down to 25°F (-4°C).
 - 3. Unit shall discharge supply air vertically or horizontally as shown on contract drawings.
 - 4. Unit shall be factory configured for vertical supply and return configurations.
 - 5. Unit shall be field convertible from vertical to horizontal airflow on all models. No special kit required.
 - 6. Unit shall be capable of mixed operation: vertical supply with horizontal return or horizontal supply with vertical return.
- F. (23 81 19.13.F.) Electrical Requirements:
 - 1. Main power supply voltage, phase, and frequency must match those required by the manufacturer.
- G. (23 81 19.13.G.) Unit Cabinet:
 - 1. Unit cabinet shall be constructed of galvanized steel, and shall be bonderized and coated with a pre-painted baked enamel finish on all externally exposed surfaces.
 - 2. Unit cabinet exterior paint shall be: film thickness, (dry) 0.003 in. minimum, gloss (per ASTM D523, 60°F/16°C): 60, Hardness: H-2H Pencil hardness.
 - 3. Evaporator fan compartment interior cabinet insulation shall conform to AHRI Standards 210/240 minimum exterior sweat criteria. Interior surfaces shall be insulated with a minimum 1/2 in. thick, 1 lb density, flexible fiberglass insulation, neoprene coated on the air side. Aluminum foil-faced fiberglass insulation shall be used in the heat compartment.
 - 4. Base of unit shall have a minimum of 4 locations for thru-the-base gas and electrical connections (factory-installed or field-installed), standard.
- 5. Base Rail:
 - a. Unit shall have base rails on a minimum of 2 sides.
 - b. Holes shall be provided in the base rails for rigging shackles to facilitate maneuvering and overhead rigging.
 - c. Holes shall be provided in the base rail for moving the rooftop by fork truck.
 - d. Base rail shall be a minimum of 16 gauge thickness.
- 6. Condensate Pan and Connections:
 - a. Shall be a sloped condensate drain pan made of a corrosion resistant material.
 - b. Shall comply with ASHRAE Standard 62.
 - c. Shall use a 3/4 in. 14 NPT drain connection, possible either through the bottom or side of the drain pan. Connection shall be made per manufacturer's recommendations.
- 7. Top Panel:
 - a. Shall be a single piece top panel on all sizes.
- 8. Electrical Connections:
 - a. All unit power wiring shall enter unit cabinet at a single, factory prepared, knockout location.
 - b. Thru-the-Base Capability.
 - 1) Standard unit shall have a thru-the-base electrical location(s) using a raised, embossed portion of the unit basepan.
 - 2) Optional, factory approved, water-tight connection method must be used for thru-the-base electrical connections.
 - 3) No basepan penetration, other than those authorized by the manufacturer, is permitted.
- 9. Component Access Panels (standard):
 - a. Cabinet panels shall be easily removable for servicing.
 - b. Unit shall have one factory installed, tool-less, removable, filter access panel.
 - c. Panels covering control box, indoor fan, indoor fan motor, gas components (where applicable), and compressors shall have molded composite handles.
 - d. Handles shall be UV modified, composite. They shall be permanently attached, and recessed into the panel.
 - e. Screws on the vertical portion of all removable access panel shall engage into heat resistant, molded composite collars.
 - f. Collars shall be removable and easily replaceable using manufacturer recommended parts.

H. (23 81 19.13.H.) Coils:

1. Standard Aluminum Fin-Copper Tube Coils:
 - a. Standard evaporator and condenser coils shall have aluminum lanced plate fins mechanically bonded to seamless internally grooved copper tubes with all joints brazed.
 - b. Evaporator coils shall be leak tested to 150 psig, pressure tested to 450 psig, and qualified to UL 1995 burst test at 1775 psig.
 - c. Condenser coils shall be leak tested to 150 psig, pressure tested to 650 psig, and qualified to UL 1995 burst test at 1980 psig.
2. Optional Pre-coated Aluminum-Fin Condenser Coils (3-phase models only):
 - a. Shall have a durable epoxy-phenolic coating to provide protection in mildly corrosive coastal environments.
 - b. Coating shall be applied to the aluminum fin stock prior to the fin stamping process to create an inert barrier between the aluminum fin and copper tube.
 - c. Epoxy-phenolic barrier shall minimize galvanic action between dissimilar metals.
 - d. Corrosion durability of fin stock shall be confirmed through testing to be no less than 1000 hours salt spray per ASTM B117-90.
 - e. Corrosion durability of fin stock shall be confirmed through testing to have no visible corrosion after 48 hour immersion in a room temperature solution of 5% salt, 1% acetic acid.
 - f. Fin stock coating shall pass 2000 hours of the following: one week exposure in the prohesion chamber followed by one week of accelerated ultraviolet light testing. Prohesion chamber: the solution shall contain 3.5% sodium chloride and 0.35% ammonium sulfate. The exposure cycle is one hour of salt fog application at ambient followed by one hour drying at 95°F (35°C).
3. Optional Copper-Fin Evaporator and Condenser Coils (3-phase models only):
 - a. Shall be constructed of copper fins mechanically bonded to copper tubes and copper tube sheets.
 - b. Galvanized steel tube sheets shall not be acceptable.
 - c. A polymer strip shall prevent coil assembly from contacting the sheet metal coil pan to minimize potential for galvanic corrosion between coil and pan.
4. Optional E-coated Aluminum-Fin Evaporator and Condenser Coils (3-phase models only):
 - a. Shall have a flexible epoxy polymer coating uniformly applied to all coil surface areas without material bridging between fins.

- b. Coating process shall ensure complete coil encapsulation of tubes, fins and headers.
- c. Color shall be high gloss black with gloss per ASTM D523-89.
- d. Uniform dry film thickness from 0.8 to 1.2 mil on all surface areas including fin edges.
- e. Superior hardness characteristics of 2H per ASTM D3363-92A and cross-hatch adhesion of 4B-5B per ASTM D3359-93.
- f. Impact resistance shall be up to 160 in. lb (ASTM D2794-93).
- g. Humidity and water immersion resistance shall be up to minimum 1000 and 250 hours respectively (ASTM D2247-92 and ASTM D870-92).
- h. Corrosion durability shall be confirmed through testing to be no less than 1000 hours salt spray per ASTM B117-90.

I. (23 81 19.13.I.) Refrigerant Components:

1. Refrigerant circuit shall include the following control, safety, and maintenance features:
 - a. TXV metering system on all models shall include a multiple feed distribution system.
 - b. Refrigerant filter drier — Solid core design.
 - c. Service gauge connections on suction and discharge lines.
 - d. Pressure gauge access through a specially designed access port in the top panel of the unit.
2. There shall be gauge line access port in the skin of the rooftop, covered by a black, removable plug.
 - a. The plug shall be easy to remove and replace.
 - b. When the plug is removed, the gauge access port shall enable maintenance personnel to route their pressure gauge lines.
 - c. This gauge access port shall facilitate correct and accurate condenser pressure readings by enabling the reading with the compressor access panel on.
 - d. The plug shall be made of a leak proof, UV-resistant, composite material.
3. Compressors:
 - a. Unit shall use fully hermetic, 2-stage scroll compressor on a single refrigeration circuit.
 - b. Compressor motors shall be cooled by refrigerant gas passing through motor windings.
 - c. Compressors shall be internally protected from high discharge temperature conditions.
 - d. Compressors shall be protected from an over-temperature and over-ampereage conditions by an internal, motor overload device.

- e. Compressor shall be factory mounted on rubber grommets.
 - f. Compressor motors shall have internal line break thermal, current overload and high pressure differential protection.
 - g. Crankcase heaters shall not be required for normal operating range, unless required by compressor manufacturer due to refrigerant charge limits.
- J. (23 81 19.13.J.) Filter Section:
- 1. Filters access is specified in the unit cabinet section of this specification.
 - 2. Filters shall be held in place by a pivoting filter tray, facilitating easy removal and installation.
 - 3. Shall consist of factory installed, low velocity, throw-away 2 in. thick fiberglass filters.
 - 4. Filters shall be standard, commercially available sizes.
 - 5. Only one size filter per unit is allowed.
- K. (23 81 19.13.K.) Evaporator Fan and Motor with EcoBlue™ Technology:
- 1. Direct Drive Evaporator Fan Motor:
 - a. Shall be a ECM motor design.
 - b. Shall have permanently lubricated bearings.
 - c. Shall have inherent automatic-reset thermal overload protection.
 - d. Shall have slow ramp up to speed capabilities.
 - e. Shall require no fan/motor belts for operation, adjustments and or initial fan speed set up.
 - f. Fan DC voltage set up on Unit Control Board can eliminate the need of removal of blower access door, required on conventional belt drive systems.
 - g. Shall be internally protected from electrical phase reversal and loss.
 - 2. Evaporator Fan:
 - a. Shall be easily set with selection switch and adjustment pot on unit control board or through SystemVu™ controller.
 - b. On all sizes 04-06 which have 2-stage cooling capacity control, the indoor fan speed is automatically controlled to meet the AHRI performance requirement with 75% low fan speed and 100% at full fan speed operation
 - c. Blower fan shall be a Vane Axial fan design with 75% less moving parts than a conventional belt drive system.
 - d. Shall be constructed of a cast aluminum stator and high impact composite material on rotor and air inlet casing.
 - e. Shall be a patented / pending design with a corrosion resistant material and dynamically balanced.
- f. Shall have slow ramp up to speed capabilities to help reduce sound and comfort issues typically associated with single speed belt drive systems.
 - g. Shall be a slide out design with 2 screw removal.
3. Shall include an easily accessible Unit Control Board to conveniently and safely provide connection points for vital control functions such as: smoke detectors, phase monitor, gas controller, economizer, thermostat, DDC control options, and low and high pressure switches. Controller shall also provide an intuitive means to adjust the indoor fan speed through a simple switch and pot adjustment design.
- L. (23 81 19.13.L.) Condenser Fans and Motors:
- 1. Condenser Fan Motors:
 - a. Shall be a totally enclosed motor.
 - b. Shall use permanently lubricated bearings.
 - c. Shall have inherent thermal overload protection with an automatic reset feature.
 - d. Shall use a shaft-down design on all sizes.
 - 2. Condenser Fans:
 - a. Shall be a direct-driven propeller type fan constructed of high impact composite material.
 - b. Shall have high impact composite blades completely formed into one piece without blade fasteners or connectors and shall be dynamically balanced.
- M. (23 81 19.13.M.) Special Features Options and Accessories:
- 1. Integrated EconomizerONE and EconoMi\$er® 2 Low Leak Rate Models. (Factory installed on 3-phase models only. Field-installed on all 3 and 1 phase models.)
 - a. Integrated, gear driven opposing modulating blade design type capable of simultaneous economizer and compressor operation.
 - b. Independent modules for vertical or horizontal return configuration shall be available. Vertical return modules shall be available as a factory installed option.
 - c. Damper blades shall be galvanized steel with composite gears. Plastic or composite blades on intake or return shall not be acceptable.
 - d. Shall include all hardware and controls to provide free cooling with outdoor air when temperature and/or humidity are below setpoints.
 - e. Shall be equipped with gear driven dampers for both the outdoor ventilation air and the return air for positive air stream control.
 - f. Low leak rate shall be equipped with dampers not to exceed 2% leakage at 1 in. wg pressure differential.

- g. Economizer controller on EconomizerONE models shall be Siemens POL224 that provides:
 - 1) Combined minimum and DCV maximum damper position potentiometers with compressor staging relay.
 - 2) Functions with solid-state analog enthalpy or dry bulb changeover control sensing.
 - 3) LED indication for free cooling, sensor, and damper operation.
 - 4) One-line LCD interface screen for setup, configuration and troubleshooting.
 - 5) On-board Fault Detection and Diagnostics (FDD) that senses and alerts when the economizer is not operating properly, per California Title 24, ASHRAE 90.1 and IECC.
 - 6) Sensor failure loss of communication identification.
 - 7) Capabilities for use with multiple-speed or single speed indoor fan systems.
 - 8) Digital sensors: Dry bulb and Enthalpy.
 - h. Economizer controller on EconoMi\$er® 2 models with RTU Open or SystemVu controllers shall be a 4-20mA design controlled directly by the controller. RTU Open and SystemVu meet California Title 24, ASHRAE 90.1 and IECC¹ Fault Detection and Diagnostic (FDD) requirements.
 - i. Shall be capable of introducing up to 100% outdoor air.
 - j. Shall be equipped with a barometric relief damper capable of relieving up to 100% return air and contain seals that meet ASHRAE 90.1 requirements.
 - k. Shall be designed to close damper(s) during loss-of-power situations with spring return built into motor.
 - l. Dry bulb outdoor air temperature sensor shall be provided as standard. Enthalpy sensor is also available on factory installed only. Outdoor air sensor setpoint shall be adjustable and shall range from 40°F to 100°F (4°C to 38°C). Additional sensor options shall be available as accessories.
 - m. The economizer controller shall also provide control of an accessory power exhaust unit function. Factory set at 100%, with a range of 0% to 100%.
 - n. The economizer shall maintain minimum airflow into the building during occupied period and provide design ventilation rate for full occupancy.
 - o. Dampers shall be completely closed when the unit is in the unoccupied mode.
 - p. Economizer controller shall accept a 0 to 10 vdc CO₂ sensor input for IAQ/DCV control. In this mode, dampers shall modulate the outdoor air damper to provide ventilation based on the sensor input.
 - q. Compressor lockout temperature on POL224 control is adjustable from -45°F to 80°F (-43°C to 26°C), set at a factory default of 32°F (0°C).
 - r. Actuator shall be direct coupled to economizer gear. No linkage arms or control rods shall be acceptable.
 - s. Contains LED indication for free cooling, sensor, and damper operation.
2. Integrated EconomizerONE and EconoMi\$er 2 Ultra Low Leak Rate Models. (Factory installed on 3-phase models only. Field installed on all 3 and 1-phase models.)
 - a. Integrated, gear driven opposing modulating blade design type capable of simultaneous economizer and compressor operation.
 - b. Independent modules for vertical or horizontal return configuration shall be available. Vertical return modules shall be available as a factory-installed option.
 - c. Damper blades shall be galvanized steel with composite gears. Plastic or composite blades on intake or return shall not be acceptable.
 - d. Shall include all hardware and controls to provide free cooling with outdoor air when temperature and/or humidity are below setpoints.
 - e. Shall be equipped with gear driven dampers for both the outdoor ventilation air and the return air for positive air stream control.
 - f. Ultra Low Leak design meets California Title 24 section 140.4 and ASHRAE 90.1 requirements for 4 cfm per sq. ft on the outside air dampers and 10 cfm per sq. ft on the return dampers.
 - g. Economizer controller on EconomizerONE models shall be the Siemens POL224 that provides:
 - 1) One-line LCD interface screen for setup, configuration and troubleshooting.
 - 2) On-board Fault Detection and Diagnostics (FDD) that senses and alerts when the economizer is not operating properly, per California Title 24, ASHRAE 90.1 and IECC.
 - 3) Sensor failure loss of communication identification.
 - 4) Capabilities for use with multiple-speed indoor fan systems.
 - 5) Digital sensors: Dry bulb and Enthalpy.

1. Third-party trademarks and logos are the property of their respective owners.

- h. Economizer controller on EconoMi\$er® 2 models with RTU Open or SystemVu controls shall be a 4 to 20mA design controlled directly by the controller. RTU Open and SystemVu meet California Title 24, ASHRAE 90.1 and IECC Fault Detection and Diagnostic (FDD) requirements.
 - i. Shall be capable of introducing up to 100% outdoor air.
 - j. Shall be equipped with a barometric relief damper capable of relieving up to 100% return air and contain seals that meet ASHRAE 90.1 requirements.
 - k. Shall be designed to close damper(s) during loss-of-power situations with spring return built into motor.
 - l. Dry bulb outdoor air temperature sensor shall be provided as standard. Enthalpy sensor is also available on factory installed only. Outdoor air sensor setpoint shall be adjustable and shall range from 40°F to 100°F (4°C to 38°C). Additional sensor options shall be available as accessories.
 - m. The economizer controller shall also provide control of an accessory power exhaust unit function. Factory set at 100%, with a range of 0% to 100%.
 - n. The economizer shall maintain minimum airflow into the building during occupied period and provide design ventilation rate for full occupancy.
 - o. Dampers shall be completely closed when the unit is in the unoccupied mode.
 - p. Economizer controller shall accept a 0 to 10 vdc CO₂ sensor input for IAQ/DCV control. In this mode, dampers shall modulate the outdoor air damper to provide ventilation based on the sensor input.
 - q. Compressor lockout temperature on POL224 control is adjustable from -45°F to 80°F (-43°C to 26°C), set at a factory default of 32°F (0°C).
 - r. Actuator shall be direct coupled to economizer gear. No linkage arms or control rods shall be acceptable.
 - s. Contains LED indication for free cooling, sensor, and damper operation.
3. Wi-Fi/WLAN Stick for EconomizerONE POL224 (field-installed):
This item allows use of the Siemens Climatix™¹ mobile application.
4. Two-Position Damper (field-installed only):
- a. Damper shall be a Two-Position Damper. Damper travel shall be from the full closed position to the field adjustable %-open setpoint.
 - b. Damper shall include adjustable damper travel from 25% to 100% (full open).
 - c. Damper shall include single or dual blade, gear driven dampers and actuator motor.
 - d. Actuator shall be direct coupled to damper gear. No linkage arms or control rods shall be acceptable.
 - e. Damper will admit up to 100% outdoor air for applicable rooftop units.
 - f. Damper shall close upon indoor (evaporator) fan shutoff and/or loss of power.
 - g. The damper actuator shall plug into the rooftop unit's wiring harness plug. No hard wiring shall be required.
 - h. Outside air hood shall include aluminum water entrainment filter.
5. Manual Damper (field-installed only):
- a. Manual damper package shall consist of damper, air inlet screen, and rain hood which can be pre-set to admit up to 25% or 50% outdoor air for year round ventilation.
6. Humidi-MiZer® Adaptive Dehumidification System (3-phase models only):
- a. The Humidi-MiZer Adaptive Dehumidification System shall be factory installed and shall provide greater dehumidification of the occupied space by 2 modes of dehumidification operations in addition to its normal design cooling mode:
 - 1) Subcooling mode further sub cools the hot liquid refrigerant leaving the condenser coil when both temperature and humidity in the space are not satisfied.
 - 2) Hot gas reheat mode shall mix a portion of the hot gas from the discharge of the compressor with the hot liquid refrigerant leaving the condenser coil to create a 2-phase heat transfer in the system, resulting in a neutral leaving air temperature when only humidity in the space is not satisfied.
 - 3) Includes low ambient controller.
7. Low Ambient Control Package:
- a. Controller shall control coil head pressure by condenser fan speed modulation or condenser fan cycling and wind baffles.
 - b. Shall consist of solid-state control and condenser coil temperature sensor to maintain condensing temperature between 90°F (32°C) and 110°F (43°C) at outdoor ambient temperatures down to -20°F (-29°C).

1. Third-party trademarks and logos are the property of their respective owners.

8. Condenser Coil Hail Guard Assembly (Factory-installed on 3-phase models only. Field-installed on all 3 and 1-phase models.)
 - a. Shall protect against damage from hail.
 - b. Shall be either hood style or louvered.
9. Unit-Mounted, Non-Fused Disconnect Switch (Available on units with MOCPS of 80 amps or less):
 - a. Switch shall be factory installed, internally mounted.
 - b. National Electric Code (NEC) and UL approved non-fused switch shall provide unit power shutoff.
 - c. Shall be accessible from outside the unit.
 - d. Shall provide local shutdown and lockout capability.
 - e. Sized only for the unit as ordered from the factory. Does not accommodate field-installed devices.
10. HACR Breaker:
 - a. These manual reset devices provide overload and short circuit protection for the unit. Factory wired and mounted with the units, with access cover to help provide environmental protection. On 575V applications, HACR breaker can only be used with WYE power distribution systems. Use on Delta power distribution systems is prohibited.
 - b. Sized only for the unit as ordered from the factory. Does not accommodate field-installed devices.
11. Convenience Outlet:
 - a. Powered Convenience Outlet. (3-phase models only)
 - 1) Outlet shall be powered from main line power to the rooftop unit.
 - 2) Outlet shall be powered from line side or load side of disconnect by installing contractor, as required by code. If outlet is powered from load side of disconnect, unit electrical ratings shall be UL certified and rated for additional outlet amperage.
 - 3) Outlet shall be factory-installed and internally mounted with easily accessible 115-v female receptacle.
 - 4) Outlet shall include 15 amp GFI receptacles with independent fuse protection.
 - 5) Voltage required to operate convenience outlet shall be provided by a factory installed step-down transformer.
 - 6) Outlet shall be accessible from outside the unit.
 - 7) Outlet shall include a field installed “Wet in Use” cover.
 - b. Factory-Installed Non-Powered Convenience Outlet.
 - 1) Outlet shall be powered from a separate 115/120-v power source.
 - 2) A transformer shall not be included.
 - 3) Outlet shall be factory-installed and internally mounted with easily accessible 115-v female receptacle.
 - 4) Outlet shall include 15 amp GFI receptacles with independent fuse protection.
 - 5) Outlet shall be accessible from outside the unit.
 - 6) Outlet shall include a field installed “Wet in Use” cover.
 - c. Field-Installed Non-Powered Convenience Outlet.
 - 1) Outlet shall be powered from a separate 115/120-v power source.
 - 2) A transformer shall not be included.
 - 3) Outlet shall be field-installed and internally mounted with easily accessible 115-v female receptacle.
 - 4) Outlet shall include 20 amp GFI receptacles. This kit provides a flexible installation method which allows code compliance for height requirements of the GFCI outlet from the finished roof surface as well as the capability to relocate the outlet to a more convenient location.
 - 5) Outlet shall be accessible from outside the unit.
 - 6) Outlet shall include a field installed “Wet in Use” cover.
12. Thru-the-Base Connectors:
 - a. Kits shall provide connectors to permit gas and electrical connections to be brought to the unit through the unit basepan.
 - b. Minimum of 4 connection locations per unit.
13. Propeller Power Exhaust:
 - a. Power exhaust shall be used in conjunction with an integrated economizer.
 - b. Independent modules for vertical or horizontal return configurations shall be available.
 - c. Horizontal power exhaust is shall be mounted in return ductwork.
 - d. Power exhaust shall be controlled by economizer controller operation. Exhaust fans shall be energized when dampers open past the 0 to 100% adjustable setpoint on the economizer control.
14. Roof Curbs (Vertical):
 - a. Full perimeter roof curb with exhaust capability providing separate air streams for energy recovery from the exhaust air without supply air contamination.

- b. Formed galvanized steel with wood nailer strip and shall be capable of supporting entire unit weight.
 - c. Permits installation and securing of ductwork to curb prior to mounting unit on the curb.
15. Outdoor Air Enthalpy Sensor:
- a. The outdoor air enthalpy sensor shall be used to provide single enthalpy control. When used in conjunction with a return air enthalpy sensor, the unit will provide differential enthalpy control. The sensor allows the unit to determine if outside air is suitable for free cooling.
16. Return Air Enthalpy Sensor:
- a. The return air enthalpy sensor shall be used in conjunction with an outdoor air enthalpy sensor to provide differential enthalpy control.
17. Indoor Air Quality (CO₂) Sensor:
- a. Shall be able to provide demand ventilation indoor air quality (IAQ) control.
 - b. The IAQ sensor shall be available in duct mount, wall mount, or wall mount with LED display. The setpoint shall have adjustment capability.
18. Smoke Detectors (factory-installed only):
- a. Shall be a 4-wire controller and detector.
 - b. Shall be environmental compensated with differential sensing for reliable, stable, and drift-free sensitivity.
 - c. Shall use magnet-activated test/reset sensor switches.
 - d. Shall have tool-less connection terminal access.
 - e. Shall have a recessed momentary switch for testing and resetting the detector.
 - f. Controller shall include:
 - 1) One set of normally open alarm initiation contacts for connection to an initiating device circuit on a fire alarm control panel.
 - 2) Two Form-C auxiliary alarm relays for interface with rooftop unit or other equipment.
 - 3) One Form-C supervision (trouble) relay to control the operation of the Trouble LED on a remote test/reset station.
 - 4) Capable of direct connection to 2 individual detector modules.
 - 5) Can be wired to up to 14 other duct smoke detectors for multiple fan shut-down applications.
19. Winter Start Kit:
- a. Shall contain a bypass device around the low pressure switch.
 - b. Shall be required when mechanical cooling is required down to 25°F (-4°C).
 - c. Shall not be required to operate on an economizer when below an outdoor ambient of 35°F (2°C).
20. Time Guard:
- a. Shall prevent compressor short-cycling by providing a 5 minute delay (±2 minutes) before restarting a compressor after shut-down for any reason.
 - b. One device shall be required per compressor.
21. Hinged Access Panels:
- a. Shall provide easy access through integrated quarter turn latches.
 - b. Shall be on major panels of: filter, control box, fan motor, and compressor.
22. Condensate Overflow Switch:
- a. This sensor and related controller monitors the condensate level in the drain pan and shuts down compression operation when overflow conditions occur. It includes:
 - 1) Indicator light — solid red (more than 10 seconds on water contact — compressors disabled), blinking red (sensor disconnected).
 - 2) 10 second delay to break — eliminates nuisance trips from splashing or waves in pan (sensor needs 10 seconds of constant water contact before tripping).
 - 3) Disables the compressor(s) operation when condensate plug is detected, but still allows fans to run for economizer.
23. Foil Faced Insulation:
- a. Throughout unit cabinet air stream, non-fibrous and cleanable foil faced insulation is used.
24. MERV-13 Return Air Filters:
- a. Factory option to upgrade standard unit filters to MERV-13 filters.
25. Phase Monitor Control:
- a. Shall monitor the sequence of 3-phase electrical system to provide a phase reversal protection
 - b. Shall monitor the 3-phase voltage inputs to provide a phase loss protection for the 3-phase device.
 - c. Will work on either a Delta or Wye power connection.
26. Horn/Strobe Annunciator:
- a. Provides an audible/visual signaling device for use with factory-installed option or field installed accessory smoke detectors.
 - 1) Requires installation of a field-supplied 24-v transformer suitable for 4.2 VA (AC)

or 3.0 VA (DC) per horn/strobe accessory.

- 2) Requires field-supplied electrical box, North American 1-gang box, 2 in. (51 mm) x 4 in. (102 mm).
- 3) Shall have a clear colored lens.

27. Electric Heat:

a. Heating Section:

- 1) Heater element open coil resistance wire, nickel-chrome alloy, 0.29 in. inside diameter, strung through ceramic insulators

mounted on metal frame. Coil ends are staked and welded to terminal screw slots.

- 2) Heater assemblies are provided with integral fusing for protection of internal heater circuits not exceeding 48 amps each. Auto reset thermo limit controls, magnetic heater contactors (24-v coil) and terminal block all mounted in electric heater control box (minimum 18 ga galvanized steel) attached to end of heater assembly.

