



WeatherMaker® 50FCQ*17-28 Single Package Rooftop Heat Pump with Puron® (R-410A) Refrigerant and EcoBlue™ Fan Technology

Installation Instructions

CONTENTS

	Page
SAFETY CONSIDERATIONS	1
GENERAL	2
Rated Indoor Airflow (cfm)	2
INSTALLATION	14
Job-Site Survey	14
Step 1 — Plan for Unit Location	14
• ROOF MOUNT	
Step 2 — Plan for Sequence of Unit Installation ..	14
• CURB-MOUNTED INSTALLATION	
• PAD-MOUNTED INSTALLATION	
• FRAME-MOUNTED INSTALLATION	
Step 3 — Inspect Unit	14
Step 4 — Provide Unit Support	14
• ROOF CURB MOUNT	
• SLAB MOUNT (HORIZONTAL UNITS ONLY)	
• ALTERNATE UNIT SUPPORT (IN LIEU OF CURB MOUNT)	
Step 5 — Field Fabricate Ductwork	18
• FOR UNITS WITH ACCESSORY ELECTRIC HEATERS	
Step 6 — Rig and Place Unit	18
• POSITIONING ON CURB	
Step 7 — Horizontal Duct Connection	19
Step 8 — Install Outside Air Hood (Factory Option)	19
Step 9 — Assemble Barometric Hood	20
• BAROMETRIC HOOD (VERTICAL CONFIGURATION)	
• BAROMETRIC HOOD (HORIZONTAL CONFIGURATION)	
Step 10 — Install External Condensate Trap and Line	21
Step 11 — Make Electrical Connections	22
• FIELD POWER SUPPLY	
• UNITS WITHOUT FACTORY-INSTALLED NON-FUSED DISCONNECT	
• UNITS WITH FACTORY-INSTALLED NON-FUSED DISCONNECT	
• ALL UNITS	
• CONVENIENCE OUTLETS	
• FACTORY-OPTION THRU-BASE CONNECTIONS	
• FIELD CONTROL WIRING	
• THERMOSTAT	
• COMMERCIAL DEFROST CONTROL	
• ELECTRIC HEATERS	
Typical Unit Wiring Diagrams	28
EconoMi\$er X (Factory-Installed Option)	41
• PRODUCT DESCRIPTION	
• SYSTEM COMPONENTS	
• SPECIFICATIONS	
• INPUTS	
• OUTPUTS	

- ENVIRONMENTAL
- ECONOMIZER MODULE WIRING DETAILS
- S-BUS SENSOR WIRING
- CO2 SENSOR WIRING
- INTERFACE OVERVIEW
- USER INTERFACE
- KEYPAD
- MENU STRUCTURE
- SETUP AND CONFIGURATION
- TIME-OUT AND SCREENSAVER
- STANDARD OR SINGLE SPEED FAN OPERATION
- 2 SPEED FAN OPERATION
- 2SP H/C (2 SPEED HEAT/COOL) SPEED FAN OPERATION
- 3 SPEED FAN OPERATION
- ENTHALPY SETTINGS
- CHECKOUT
- TROUBLESHOOTING
- SystemVu™ Controller (Factory Option)**
- Smoke Detectors**
- ADDITIONAL APPLICATION DATA
- EconoMi\$er X Occupancy Switch**
- Step 12 — Install Accessories**
- Step 13 — Fan Speed Set Up**
- UNITS WITH ELECTRO-MECHANICAL CONTROLS
- UNITS WITH SYSTEMVU™ CONTROLS
- Typical Unit Piping**
- Pre-Start and Start-Up**
- START-UP CHECKLIST**

SAFETY CONSIDERATIONS

Installation and servicing of air-conditioning equipment can be hazardous due to system pressure and electrical components. Only trained and qualified service personnel should install, repair, or service air-conditioning equipment.

Untrained personnel can perform basic maintenance functions of cleaning coils and filters and replacing filters. All other operations should be performed by trained service personnel. When working on air-conditioning equipment, observe precautions in the literature, tags and labels attached to the unit, and other safety precautions that may apply.

Follow all safety codes, including ANSI (American National Standards Institute) Z223.1. Wear safety glasses and work gloves. Use quenching cloth for unbrazing operations. Have fire extinguisher available for all brazing operations.

It is important to recognize safety information. This is the safety-alert symbol . When you see this symbol on the unit and in instructions or manuals, be alert to the potential for personal injury.

Understand the signal words DANGER, WARNING, CAUTION, and NOTE. These words are used with the safety-alert symbol. DANGER identifies the most serious hazards which **will** result in severe personal injury or death. WARNING signifies hazards which **could** result in personal injury or death. CAUTION is used

to identify unsafe practices, which **may** result in minor personal injury or product and property damage. NOTE is used to highlight suggestions which **will** result in enhanced installation, reliability, or operation.

⚠ DANGER

ELECTRICAL SHOCK HAZARD

Failure to follow this warning will result in personal injury or death.

Before performing service or maintenance operations on unit, turn off main power switch to unit and install lock(s) and lockout tag(s). Ensure electrical service to rooftop unit agrees with voltage and amperage listed on the unit rating plate. Unit may have more than one power switch.

⚠ WARNING

UNIT OPERATION AND SAFETY HAZARD

Failure to follow this warning could cause personal injury, death and/or equipment damage.

R-410A refrigerant systems operate at higher pressures than standard R-22 systems. Do not use R-22 service equipment or components on R-410A refrigerant equipment.

⚠ WARNING

PERSONAL INJURY AND ENVIRONMENTAL HAZARD

Failure to follow this warning could cause personal injury or death.

Relieve pressure and recover all refrigerant before system repair or final unit disposal.

Wear safety glasses and gloves when handling refrigerants. Keep torches and other ignition sources away from refrigerants and oils.

⚠ CAUTION

PERSONAL INJURY HAZARD

Failure to follow this caution may result in personal injury.

Sheet metal parts may have sharp edges or burrs. Use care and wear appropriate protective clothing, safety glasses and gloves when handling parts and servicing air conditioning equipment.

GENERAL

These installation instructions cover the 50FCQ units with cooling only. Units are pre-wired and pre-charged with environmentally balanced Puron® (R-410A) refrigerant at the factory. See Fig. 1 for model number nomenclature. See Fig. 2-11 for unit dimensions. See Fig. 5 and 10 for service clearances.

Rated Indoor Airflow (cfm)

Table 1 lists the rated indoor airflow used for the AHRI efficiency rating for the units covered in this document.

Table 1 — Rated Indoor Airflow (CFM)

MODEL NUMBER	FULL LOAD AIRFLOW (CFM)
50FCQ*17	6300
50FCQ*24	8000
50FCQ*28	9500

NOTE: Unit is not designed to have overhead obstruction.

Position:	1	2	3	4	5	6	7	8	9	10	11	12	13	14	15	16	17	18
Example:	5	0	F	C	Q	M	2	4	A	2	A	6	-	0	A	0	A	0

Unit Heat Type

50 - Cooling Packaged Rooftop

Model Series - WeatherMaker®

FC - Standard Efficiency (EcoBlue™ Technology)

Heat Type

Q = Heat Pump
(Field-Installed Electric Heat)

Refrig. Systems Options

M = Two Stage Cooling/One Circuit Models

Cooling Tons

17 = 15.0 tons
24 = 20.0 tons
28 = 25.0 tons

Sensor Options

A = None
B = Return Air Smoke Detector (RA)
C = Supply Air Smoke Detector (SA)
D = RA + SA Smoke Detector
E = CO₂ Sensor
F = RA Smoke Detector and CO₂ Sensor
G = SA Smoke Detector and CO₂ Sensor
H = RA + SA Smoke Detector and CO₂ Sensor
J = Condensate Overflow Switch (COFS)
K = COFS + RA Smoke Detector
L = COFS + RA and SA Smoke Detectors
M = COFS + SA Smoke Detector
N = COFS + CO₂ Sensor
P = COFS + RA Smoke Detector and CO₂ Sensor
Q = COFS + SA Smoke Detector and CO₂ Sensor
R = COFS + RA and SA Smoke Detector and CO₂ Sensor

Indoor Fan Options - Vane Axial EcoBlue Fan System

2 = Standard/Medium Static Motor - Vertical Supply
3 = High Static Motor - Vertical Supply
5 = Standard/Medium Static Motor - Vertical Supply and Filter Status Switch
6 = High Static Motor - Vertical Supply and Filter Status Switch
J = High Static Motor - Horizontal Supply
L = High Static Motor - Horizontal Supply and Filter Status Switch

Coil Options – RTPF (Outdoor – Indoor) – Hail Guards

A = Al/Cu – Al/Cu
B = Precoat Al/Cu – Al/Cu
C = E-coat Al/Cu – Al/Cu
D = E-coat Al/Cu – E-coat Al/Cu
E = Cu/Cu – Al/Cu
F = Cu/Cu – Cu/Cu
M = Al/Cu – Al/Cu – Louvered Hail Guards
N = Precoat Al/Cu – Al/Cu – Louvered Hail Guards
P = E-coat Al/Cu – Al/Cu – Louvered Hail Guards
Q = E-coat Al/Cu – E-coat Al/Cu – Louvered Hail Guards
R = Cu/Cu – Al/Cu – Louvered Hail Guards
S = Cu/Cu – Cu/Cu – Louvered Hail Guards

Packaging Compliance

0 = Standard

Electrical Options

A = None
C = Non-Fused Disconnect
N = Phase Monitor/Protection
Q = Phase Monitor/Protection
and Non-Fused Disconnect
1 = HSCCR Protection

Service Options

0 = None
1 = Unpowered Convenience Outlet
2 = Powered Convenience Outlet
3 = Hinged Access Panels
4 = Hinged Access Panels and
Unpowered Convenience Outlet
5 = Hinged Access Panels and
Powered Convenience Outlet
6 = 4" MERV 13 High Efficiency Filter Track
7 = Unpowered Convenience Outlet and 4" MERV 13
High Efficiency Filter Track
8 = Powered Convenience Outlet and 4" MERV 13
High Efficiency Filter Track
9 = Hinged Access Panels and 4" MERV 13 High
Efficiency Filter Track
A = Hinged Access Panels, Unpowered Convenience
Outlet and 4" MERV 13 High Efficiency Filter Track
B = Hinged Access Panels, Powered Convenience
Outlet and 4" MERV 13 High Efficiency Filter Track

Intake / Exhaust Options

A = None
B = Low Leak Temp Economizer w/ Baro Relief
D = Low Leak Temp Economizer w/ PE (cent) Vert Only
F = Low Leak Enthalpy Economizer w/ Baro Relief
H = Low Leak Enthalpy Economizer w/ PE (cent) Vert Only
U = ULTRA Low Leak Temp Economizer w/ Baro Relief
V = ULTRA Low Leak Temp Economizer w/ PE (cent)
Vert Only
W = ULTRA Low Leak Enthalpy Economizer w/ Baro Relief
X = ULTRA Low Leak Enthalpy Economizer w/ PE (cent)
Vert Only

Base Unit Controls

0 = Electro-mechanical Controller
3 = SystemVu™ Controller

Design Revision

- = Factory Design Revision

Voltage

1 = 575/3/60
5 = 208-230/3/60
6 = 460/3/60

Fig. 1 — 50FCQ*17-28 Model Number Nomenclature



THIS DOCUMENT IS THE PROPERTY OF CARRIER CORPORATION AND IS DELIVERED UPON THE EXPRESS CONDITION THAT THE CONTENTS WILL NOT BE DISCLOSED OR USED WITHOUT CARRIER CORPORATION'S WRITTEN CONSENT.

SUBMISSION OF THESE DRAWINGS OR DOCUMENTS DOES NOT CONSTITUTE PART PERFORMANCE OR ACCEPTANCE OF CONTRACT.

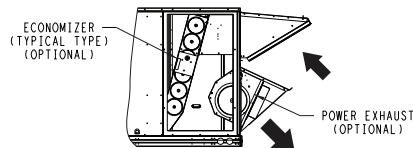

BACK
[PANELS REMOVED TO SHOW ECONOMIZER AND POWER EXHAUST OPTIONS]

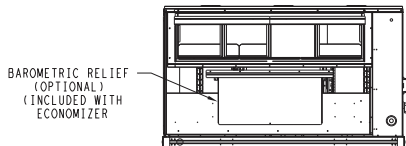

LEFT
SHOWN WITH THE BAROMETRIC RELIEF OPTION INSTALLED

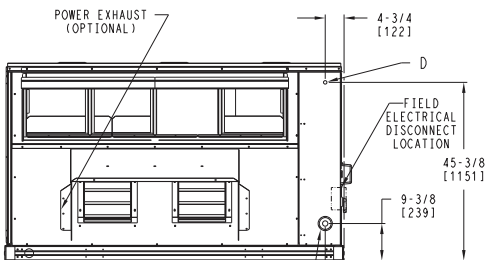

LEFT
SHOWN WITH THE POWER EXHAUST OPTION INSTALLED

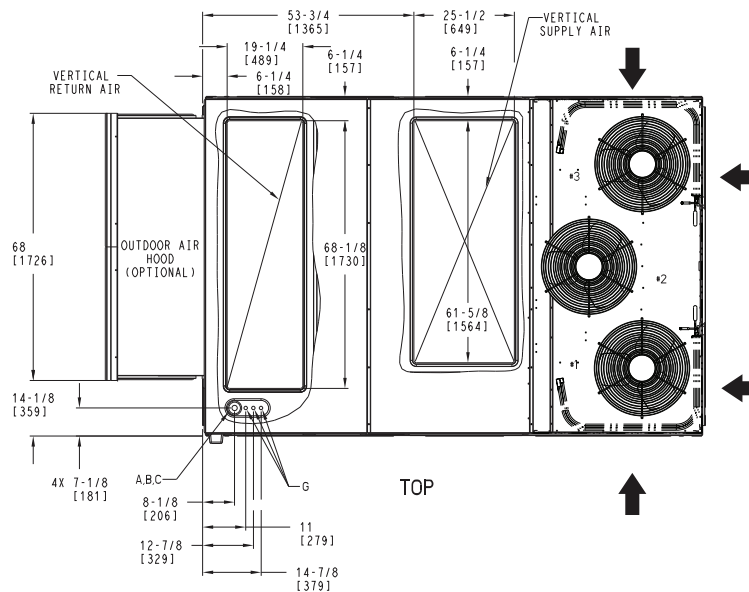

CONNECTION SIZES	
A	1 3/8" DIA [35] FIELD POWER SUPPLY KNOCKOUT
B	3" DIA [76] FIELD POWER SUPPLY KNOCKOUT
C	3 5/8" DIA [92] FIELD POWER SUPPLY KNOCKOUT
D	7/8" DIA [22] FIELD CONTROL WIRING HOLE
G	7/8" DIA [22] FIELD CONTROL WIRING KNOCKOUT

NOTES:

1. DIMENSIONS ARE IN INCHES. DIMENSIONS IN [] ARE IN MILLIMETERS.
2. CENTER OF GRAVITY
3. DIRECTION OF AIR FLOW
4. ALL VIEW DRAWN USING 3RD ANGLE

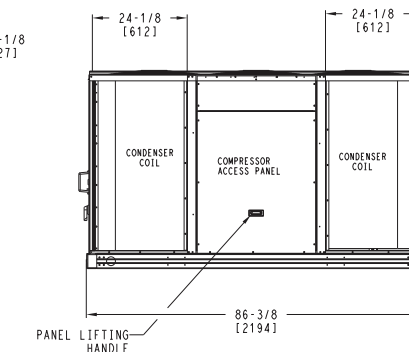
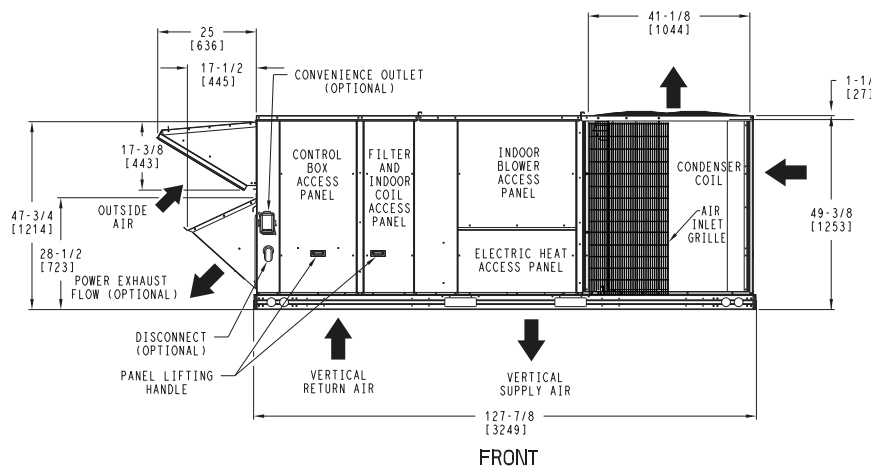

RIGHT
DEDICATED VERTICAL AIRFLOW UNIT
17 SIZE

ITC CLASSIFICATION U.S. ECCN:NSR	SHEET 1 OF 5	DATE 8/29/22	SUPERCEDES -	FCO 17 SINGLE ZONE ELECTRICAL HEAT PUMP	50HE006191	REV -
-------------------------------------	-----------------	-----------------	-----------------	--	------------	----------

Fig. 2 — 50FCQ*17 Vertical Airflow



THIS DOCUMENT IS THE PROPERTY OF CARRIER CORPORATION AND IS DELIVERED UPON THE EXPRESS CONDITION THAT THE CONTENTS WILL NOT BE DISCLOSED OR USED WITHOUT CARRIER CORPORATION'S WRITTEN CONSENT.

SUBMISSION OF THESE DRAWINGS OR DOCUMENTS DOES NOT CONSTITUTE PART PERFORMANCE OR ACCEPTANCE OF CONTRACT.

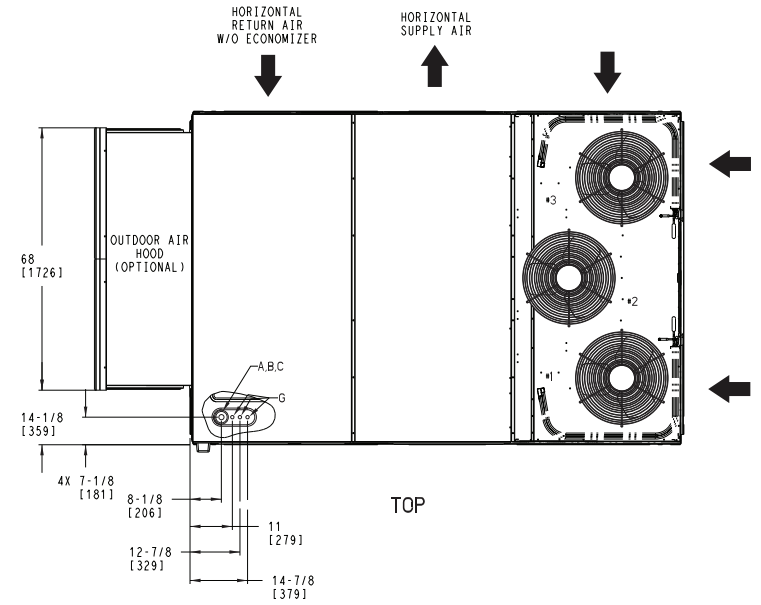
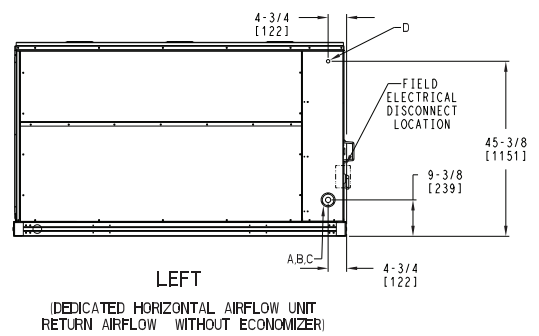
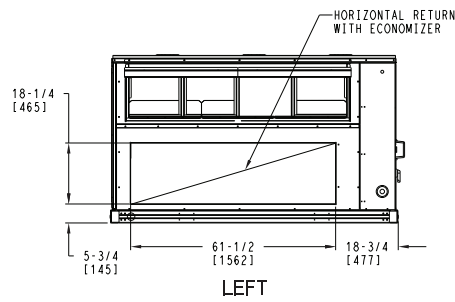
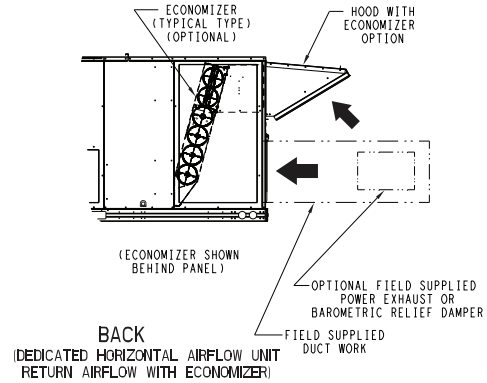

CONNECTION SIZES	
A	1 3/8" DIA [35] FIELD POWER SUPPLY KNOCKOUT
B	3" DIA [76] FIELD POWER SUPPLY KNOCKOUT
C	3 5/8" DIA [92] FIELD POWER SUPPLY KNOCKOUT
D	7/8" DIA [22] FIELD CONTROL WIRING HOLE
G	7/8" DIA [22] FIELD CONTROL WIRING KNOCKOUT

- NOTES:
1. DIMENSIONS ARE IN INCHES. DIMENSIONS IN [] ARE IN MILLIMETERS.
 2. CENTER OF GRAVITY
 3. DIRECTION OF AIR FLOW
 4. ALL VIEW DRAWN USING 3RD ANGLE

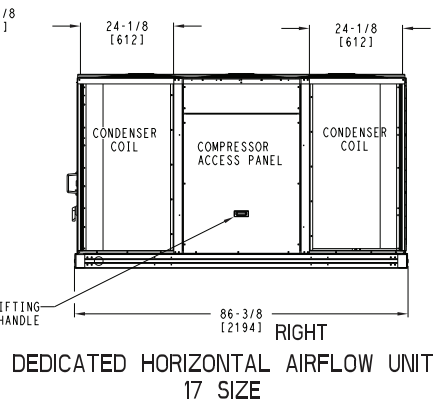
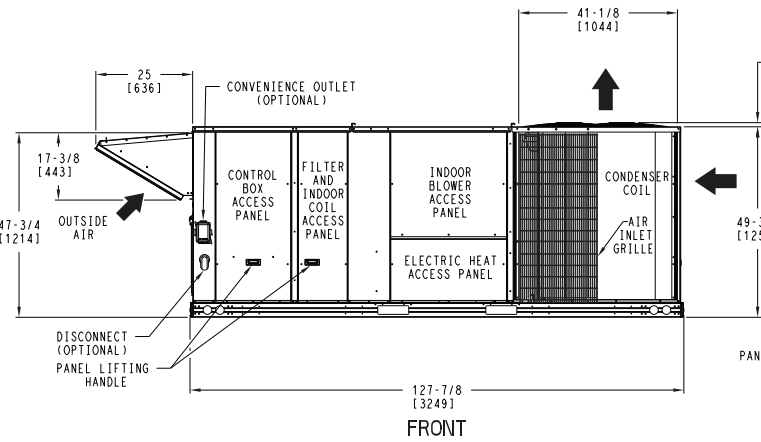

ITC CLASSIFICATION U.S. ECCN:NSR	SHEET 2 OF 5	DATE 8/29/22	SUPERCEDES -	FCQ 17 SINGLE ZONE ELECTRICAL HEAT PUMP	50HE006191	REV -
-------------------------------------	-----------------	-----------------	-----------------	--	------------	----------

Fig. 3 — 50FCQ*17 Horizontal Airflow

CONNECTION SIZES	
E	3/4"-14 NPT CONDENSATE DRAIN



THIS DOCUMENT IS THE PROPERTY OF CARRIER CORPORATION AND IS DELIVERED UPON THE EXPRESS CONDITION THAT THE CONTENTS WILL NOT BE DISCLOSED OR USED WITHOUT CARRIER CORPORATION'S WRITTEN CONSENT.

SUBMISSION OF THESE DRAWINGS OR DOCUMENTS DOES NOT CONSTITUTE PART PERFORMANCE OR ACCEPTANCE OF CONTRACT.

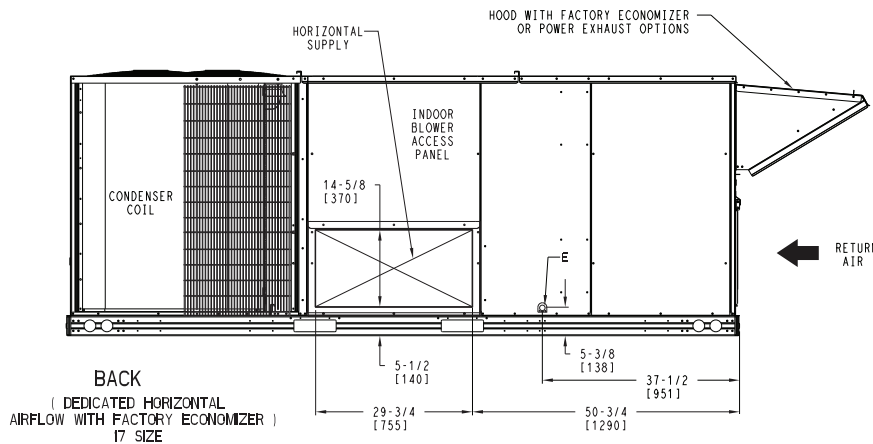
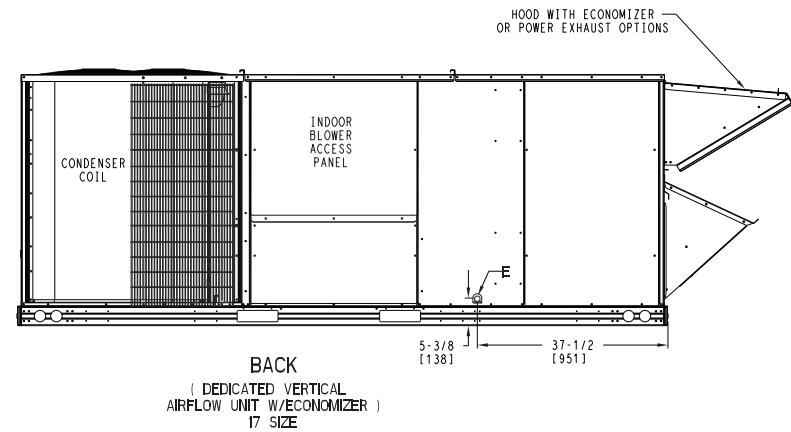
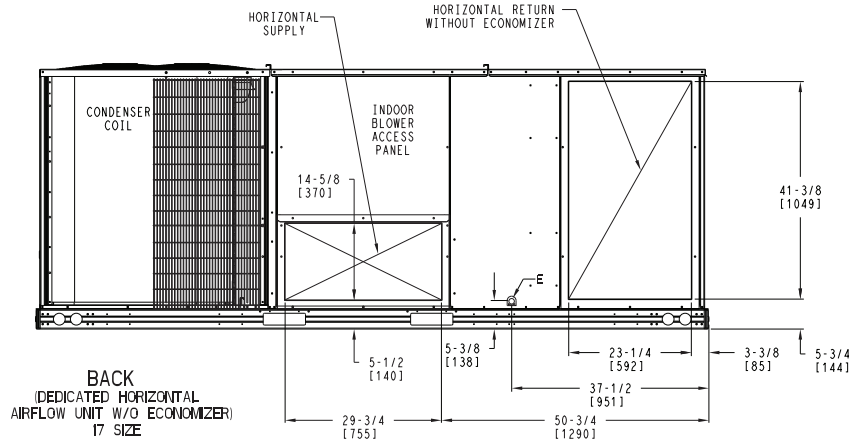

ITC CLASSIFICATION	SHEET	DATE	SUPERCEDES	FCQ 17 SINGLE ZONE ELECTRICAL HEAT PUMP	50HE006191	REV
U.S. ECCN:NSR	3 OF 5	8/29/22	-			-

Fig. 4 — 50FCQ*17 Back View and Condensate Drain Location

UNIT	STD UNIT WEIGHT *		CORNER WEIGHT (A)		CORNER WEIGHT (B)		CORNER WEIGHT (C)		CORNER WEIGHT (D)		C.G.		
	LBS.	KG.	LBS.	KG.	LBS.	KG.	LBS.	KG.	LBS.	KG.	X	Y	Z
FCQ-17	1627	738	357	162	460	209	456	207	354	161	72 [1829]	43 [1092]	16 1/2 [419]



THIS DOCUMENT IS THE PROPERTY OF CARRIER CORPORATION AND IS DELIVERED UPON THE EXPRESS CONDITION THAT THE CONTENTS WILL NOT BE DISCLOSED OR USED WITHOUT CARRIER CORPORATION'S WRITTEN CONSENT.

SUBMISSION OF THESE DRAWINGS OR DOCUMENTS DOES NOT CONSTITUTE PART PERFORMANCE OR ACCEPTANCE OF CONTRACT.

* STANDARD UNIT WEIGHT IS WITHOUT ELECTRIC HEAT AND WITHOUT PACKAGING. FOR OTHER OPTIONS AND ACCESSORIES, REFER TO THE PRODUCT DATA CATALOG.

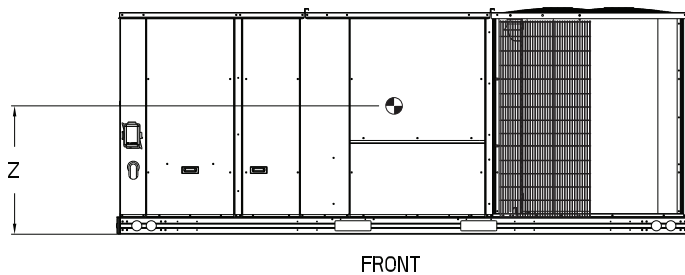
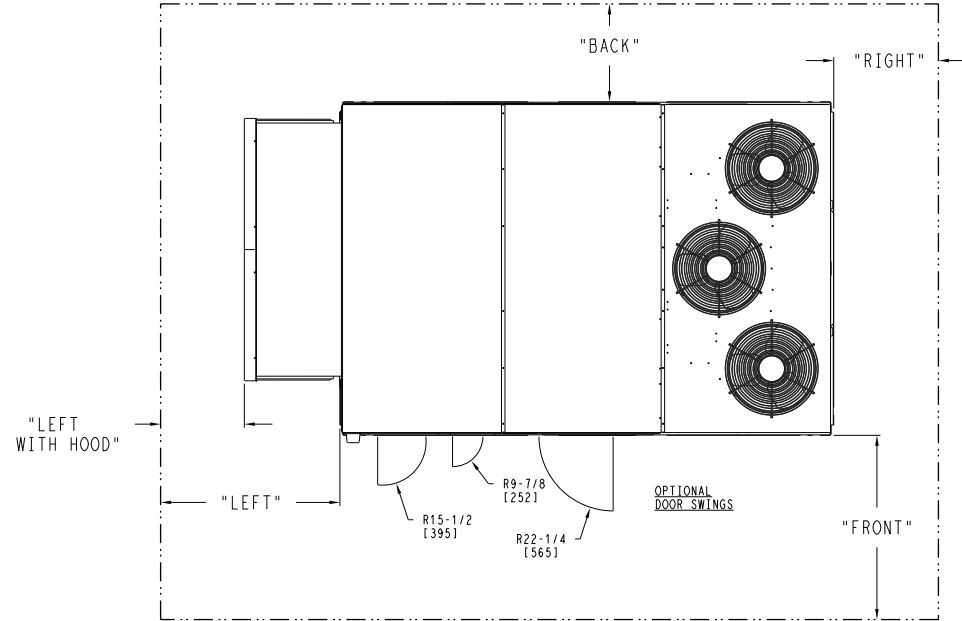
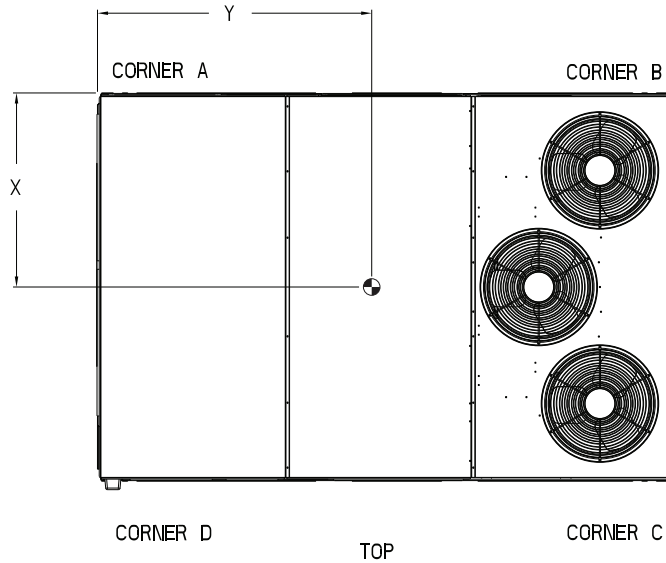

NOTES:

1. CLEARANCE ABOVE THE UNIT TO BE 72"
2. FOR ALL MINIMUM CLEARANCES LOCAL CODES OR JURISDICTIONS MAY PREVAIL.

SURFACE	SERVICE WITH:		OPERATING CLEARANCE
	CONDUCTIVE BARRIER	NONCONDUCTIVE BARRIER	
FRONT	48 [1219mm]	36 [914mm]	18 [457mm]
LEFT	48 [1219mm]	42 [1067mm]	18 [457mm]
BACK	42 [1067mm]	36 [914mm]	18 [457mm]
LEFT WITH HOOD	36 [914mm]	36 [914mm]	18 [457mm]
RIGHT	36 [914mm]	36 [914mm]	18 [457mm]
TOP	72 [1829mm]	72 [1829mm]	72 [1829mm]

ITC CLASSIFICATION	SHEET	DATE	SUPERCEDES	FCQ 17 SINGLE ZONE ELECTRICAL HEAT PUMP	50HE006191	REV
U.S. ECCN:NSR	4 OF 5	8/29/22	-			-

Fig. 5 — 50FCQ*17 Corner Weights and Clearances



THIS DOCUMENT IS THE PROPERTY OF CARRIER CORPORATION AND IS DELIVERED UPON THE EXPRESS CONDITION THAT THE CONTENTS WILL NOT BE DISCLOSED OR USED WITHOUT CARRIER CORPORATION'S WRITTEN CONSENT.

SUBMISSION OF THESE DRAWINGS OR DOCUMENTS DOES NOT CONSTITUTE PART PERFORMANCE OR ACCEPTANCE OF CONTRACT.

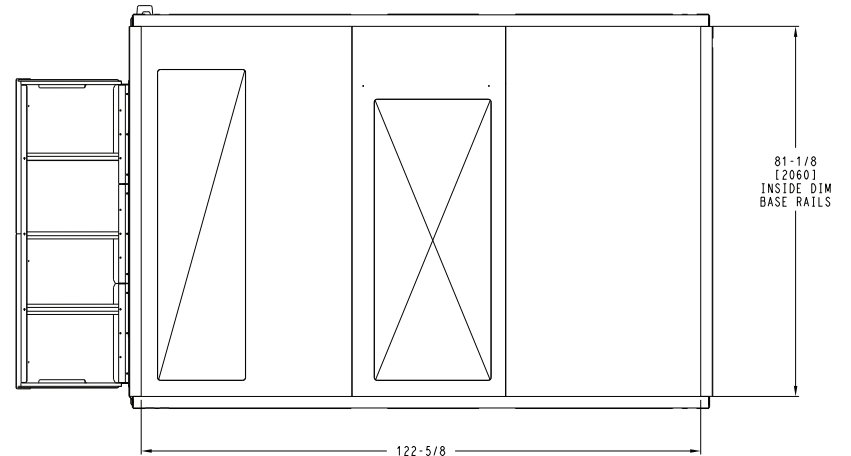
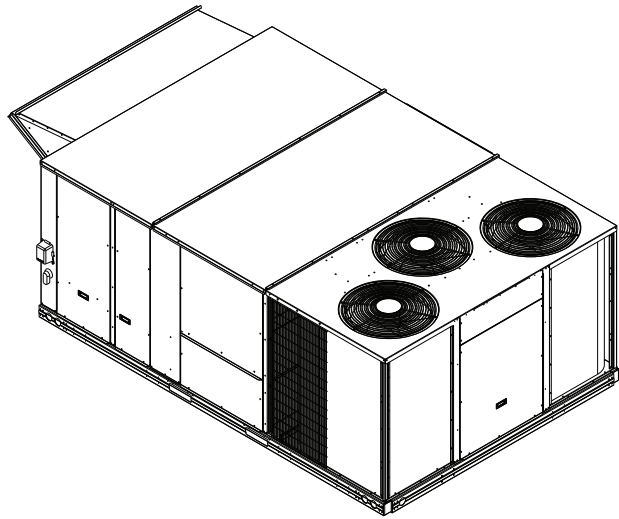

BOTTOM
INSIDE BASERAIL DIMENSIONS

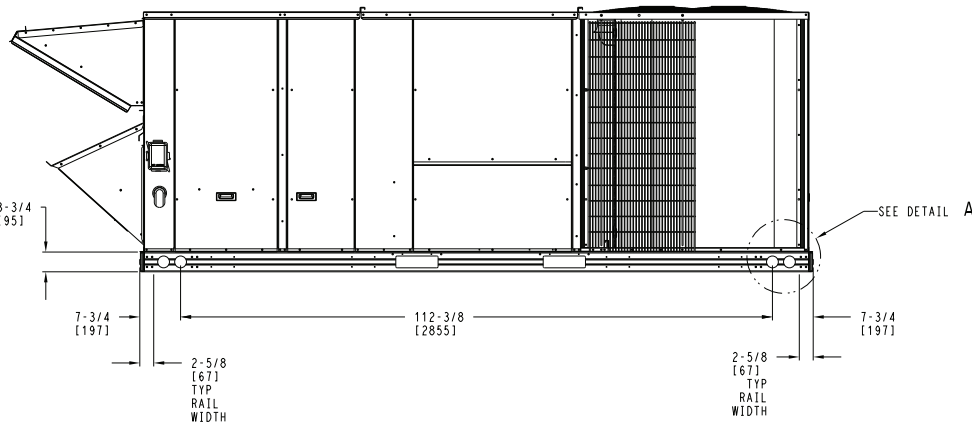

FRONT
RIGGING HOLE LOCATIONS

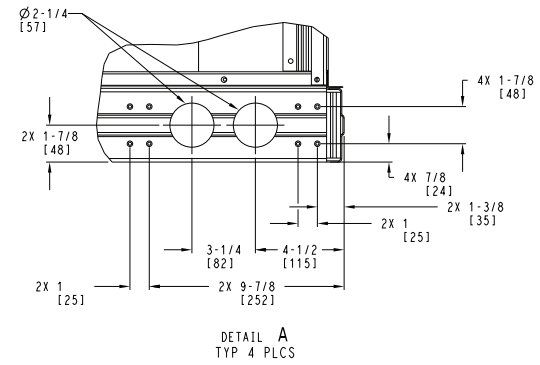

DETAIL A
TYP 4 PLCS

ITC CLASSIFICATION U.S. ECCN:NSR	SHEET 5 OF 5	DATE 8/29/22	SUPERCEDES -	FCQ 17 SINGLE ZONE ELECTRICAL HEAT PUMP	50HE006191	REV -
-------------------------------------	-----------------	-----------------	-----------------	--	------------	----------

Fig. 6 — 50FCQ*17 Bottom View



THIS DOCUMENT IS THE PROPERTY OF CARRIER CORPORATION AND IS DELIVERED UPON THE EXPRESS CONDITION THAT THE CONTENTS WILL NOT BE DISCLOSED OR USED WITHOUT CARRIER CORPORATION'S WRITTEN CONSENT.

SUBMISSION OF THESE DRAWINGS OR DOCUMENTS DOES NOT CONSTITUTE PART PERFORMANCE OR ACCEPTANCE OF CONTRACT.

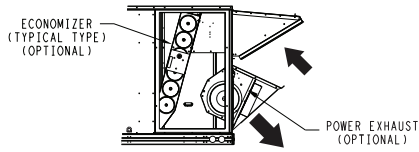

BACK

(PANELS REMOVED TO SHOW ECONOMIZER AND POWER EXHAUST OPTIONS)

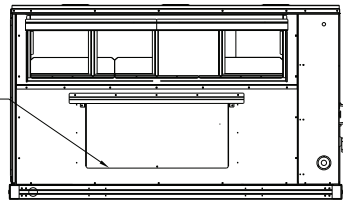

LEFT

SHOWN WITH THE BAROMETRIC RELIEF OPTION INSTALLED

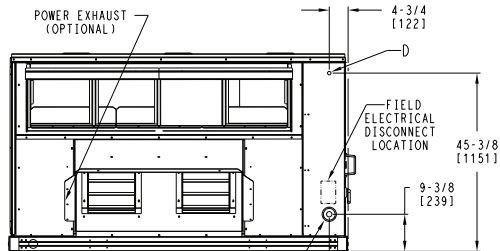

LEFT

SHOWN WITH THE POWER EXHAUST OPTION INSTALLED

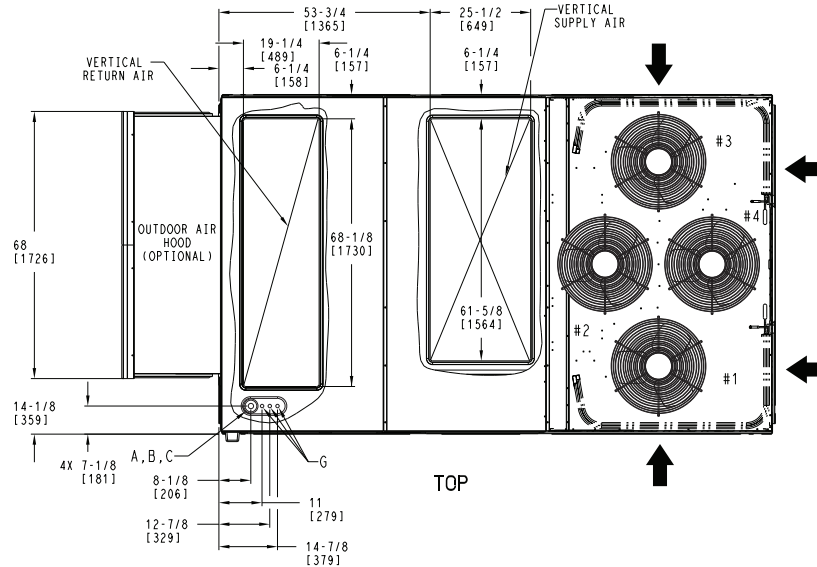

CONNECTION SIZES	
A	1 3/8" DIA [35] FIELD POWER SUPPLY KNOCKOUT
B	3" DIA [76] FIELD POWER SUPPLY KNOCKOUT
C	3 5/8" DIA [92] FIELD POWER SUPPLY KNOCKOUT
D	7/8" DIA [22] FIELD CONTROL WIRING HOLE
G	7/8" DIA [22] FIELD CONTROL WIRING KNOCKOUT

UNIT	H
24 SIZE	57-3/8 [1456]
28 SIZE	57-3/8 [1456]

NOTES:

1. DIMENSIONS ARE IN INCHES. DIMENSIONS IN [] ARE IN MILLIMETERS.
2. CENTER OF GRAVITY
3. DIRECTION OF AIR FLOW
4. ALL VIEW DRAWN USING 3RD ANGLE

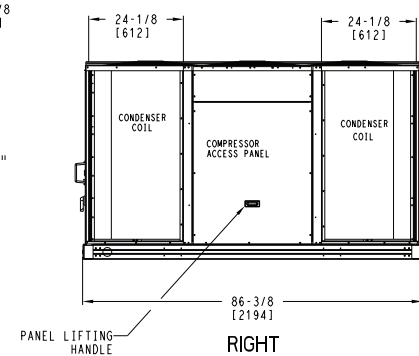
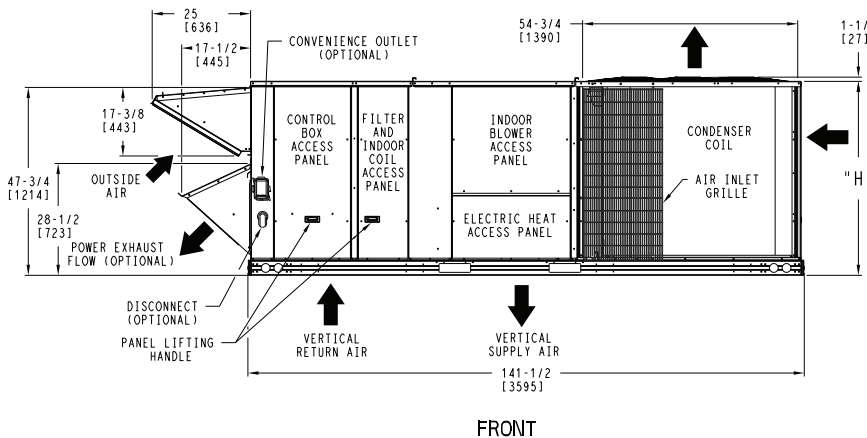

DEDICATED VERTICAL AIRFLOW UNIT
24,28 SIZE

ITC CLASSIFICATION U.S. ECCN: NSR	SHEET 1 OF 5	DATE 11/03/22	SUPERCEDES 8/29/22	FCO 24,28 SINGLE ZONE ELECTRICAL HEAT PUMP	50HE006192	REV A
--------------------------------------	-----------------	------------------	-----------------------	---	------------	----------

Fig. 7 — 50FCQ*24-28 Vertical Airflow



THIS DOCUMENT IS THE PROPERTY OF CARRIER CORPORATION AND IS DELIVERED UPON THE EXPRESS CONDITION THAT THE CONTENTS WILL NOT BE DISCLOSED OR USED WITHOUT CARRIER CORPORATION'S WRITTEN CONSENT.

SUBMISSION OF THESE DRAWINGS OR DOCUMENTS DOES NOT CONSTITUTE PART PERFORMANCE OR ACCEPTANCE OF CONTRACT.

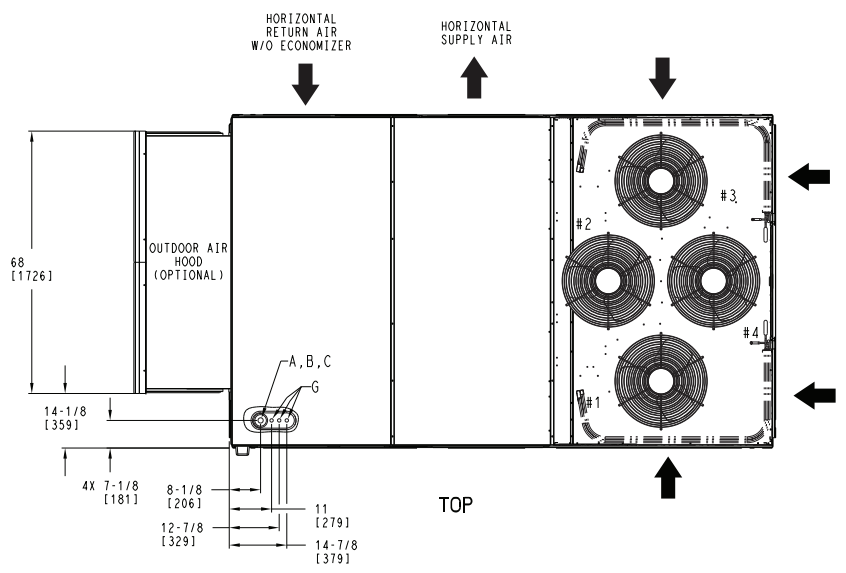
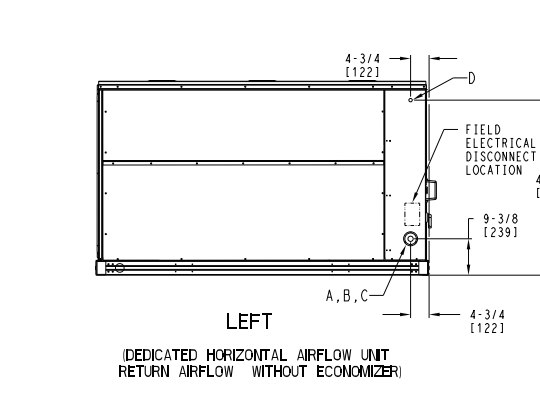
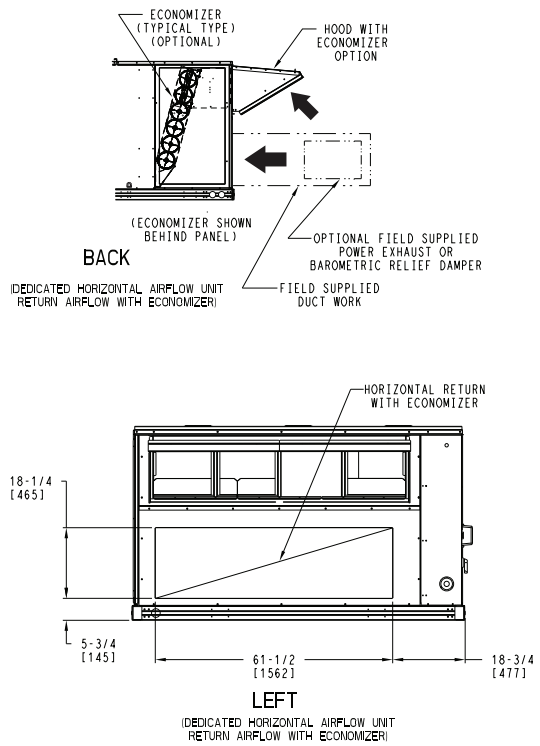

CONNECTION SIZES	
A	1 3/8" DIA [35] FIELD POWER SUPPLY KNOCKOUT
B	3" DIA [76] FIELD POWER SUPPLY KNOCKOUT
C	3 5/8" DIA [92] FIELD POWER SUPPLY KNOCKOUT
D	7/8" DIA [22] FIELD CONTROL WIRING HOLE
G	7/8" DIA [22] FIELD CONTROL WIRING KNOCKOUT

UNIT	H
24 SIZE	57-3/8 [1456]
28 SIZE	57-3/8 [1456]

- NOTES:
- DIMENSIONS ARE IN INCHES. DIMENSIONS IN [] ARE IN MILLIMETERS.
 - CENTER OF GRAVITY
 - DIRECTION OF AIR FLOW
 - ALL VIEW DRAWN USING 3RD ANGLE

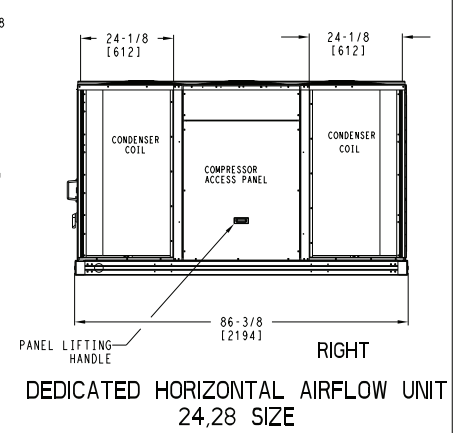
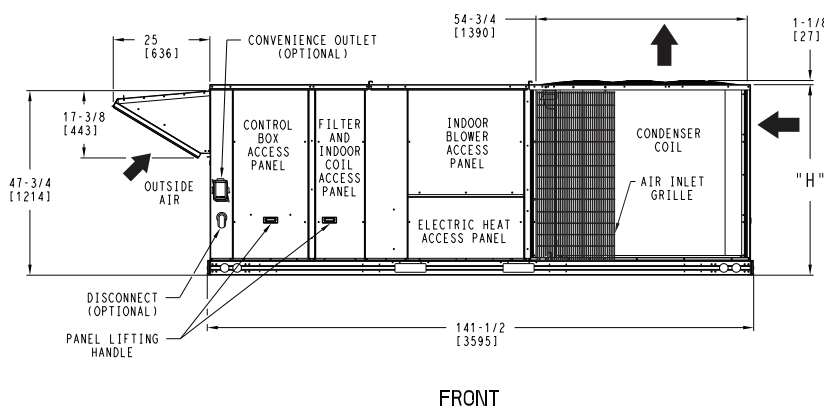

ITC CLASSIFICATION U.S. ECCN:NSR	SHEET 2 OF 5	DATE 11/03/22	SUPERCEDES 8/30/22	FCQ 24,28 SINGLE ZONE ELECTRICAL HEAT PUMP	50HE006192	REV A
-------------------------------------	-----------------	------------------	-----------------------	---	------------	----------

Fig. 8 — 50FCQ*24-28 Horizontal Airflow

CONNECTION SIZES	
E	3/4"-14 NPT CONDENSATE DRAIN



THIS DOCUMENT IS THE PROPERTY OF CARRIER CORPORATION AND IS DELIVERED UPON THE EXPRESS CONDITION THAT THE CONTENTS WILL NOT BE DISCLOSED OR USED WITHOUT CARRIER CORPORATION'S WRITTEN CONSENT.

SUBMISSION OF THESE DRAWINGS OR DOCUMENTS DOES NOT CONSTITUTE PART PERFORMANCE OR ACCEPTANCE OF CONTRACT.

UNIT	G
24 SIZE	49-1/4 [1251]
28 SIZE	49-1/4 [1251]

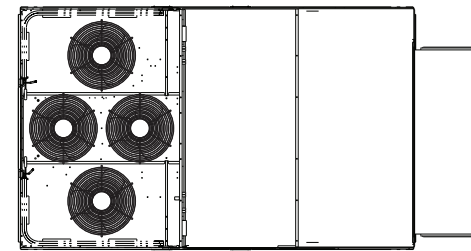
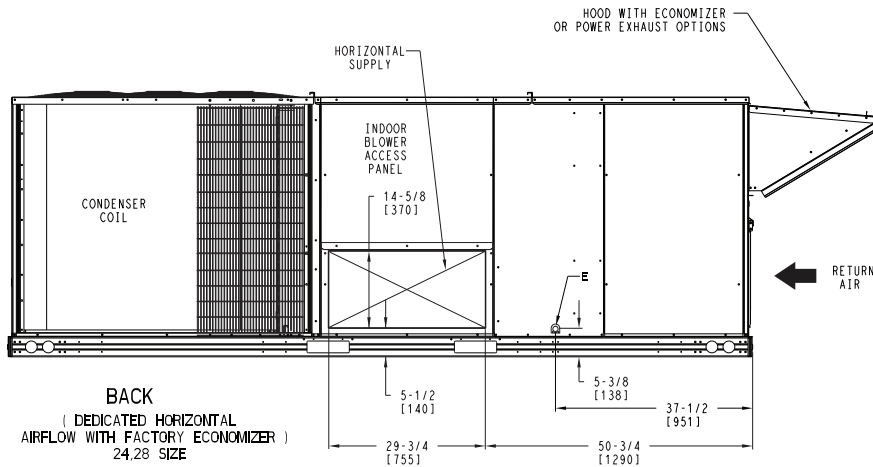
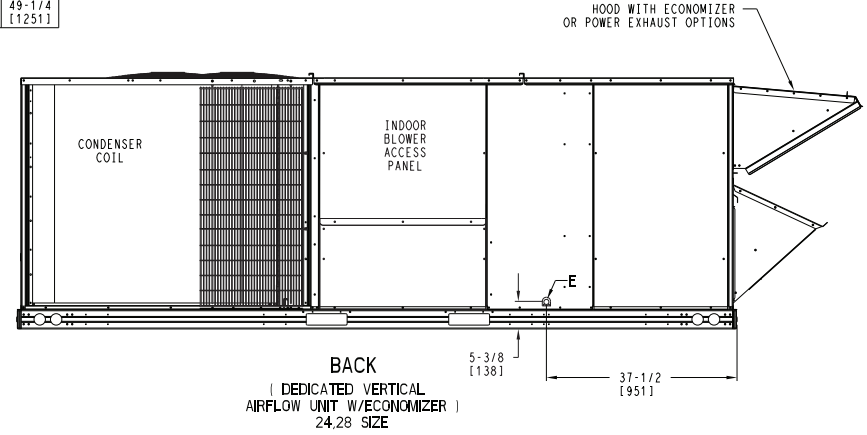
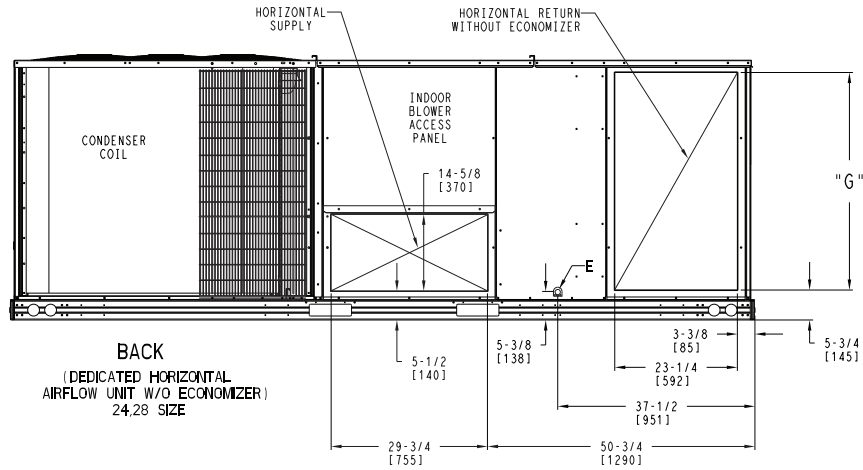

28 SIZE CONDENSER COIL TOP VIEW

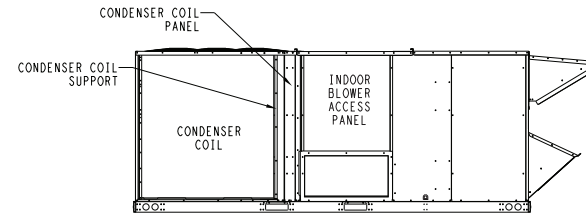

28 SIZE CONDENSER COIL END BRACKET SUPPORT

ITC CLASSIFICATION	SHEET	DATE	SUPERCEDES	FCO 24,28 SINGLE ZONE ELECTRICAL	50HE006192	REV
U.S. ECCN: NSR	3 OF 5	11/03/22	8/30/22	HEAT PUMP		A

Fig. 9 — 50FCQ*24-28 Back View and Condensate Drain Location

UNIT	STD. UNIT WEIGHT *		CORNER WEIGHT (A)		CORNER WEIGHT (B)		CORNER WEIGHT (C)		CORNER WEIGHT (D)		C.G.		
	LBS.	KG.	LBS.	KG.	LBS.	KG.	LBS.	KG.	LBS.	KG.	X	Y	Z
FCO-24	2057	933	466	211	531	241	565	256	495	225	75 3/8 [1915]	44 1/2 [1130]	19 [483]
FCO-28	2125	964	465	211	556	252	601	273	503	228	77 [1956]	44 7/8 [1140]	19 [483]

Carrier THIS DOCUMENT IS THE PROPERTY OF CARRIER CORPORATION AND IS DELIVERED UPON THE EXPRESS CONDITION THAT THE CONTENTS WILL NOT BE DISCLOSED OR USED WITHOUT CARRIER CORPORATION'S WRITTEN CONSENT. SUBMISSION OF THESE DRAWINGS OR DOCUMENTS DOES NOT CONSTITUTE PART PERFORMANCE OR ACCEPTANCE OF CONTRACT.

* STANDARD UNIT WEIGHT IS WITHOUT ELECTRIC HEAT AND WITHOUT PACKAGING. FOR OTHER OPTIONS AND ACCESSORIES, REFER TO THE PRODUCT DATA CATALOG.

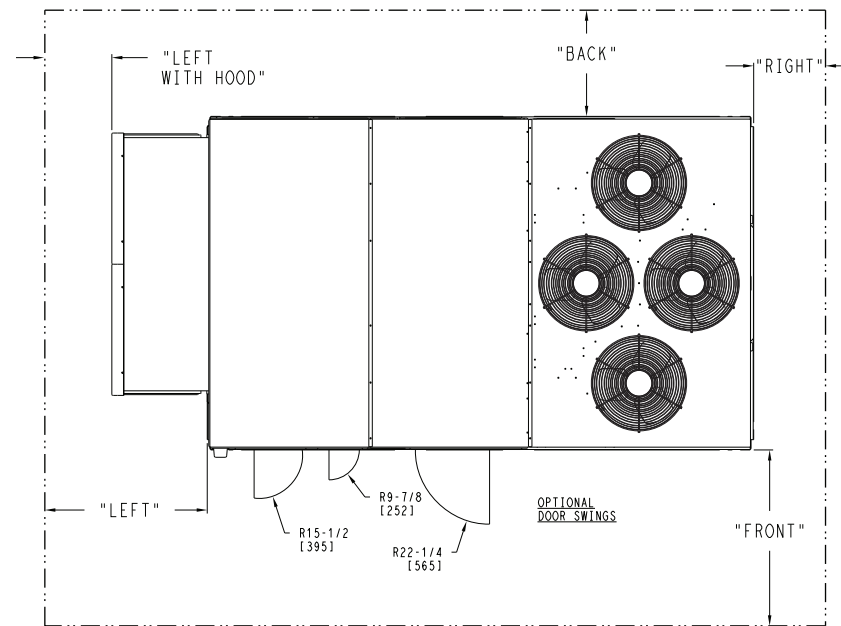
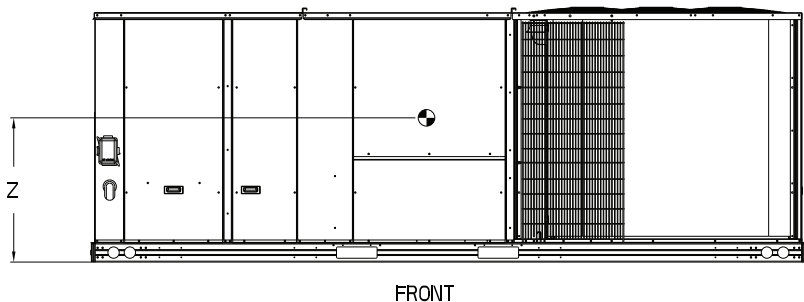
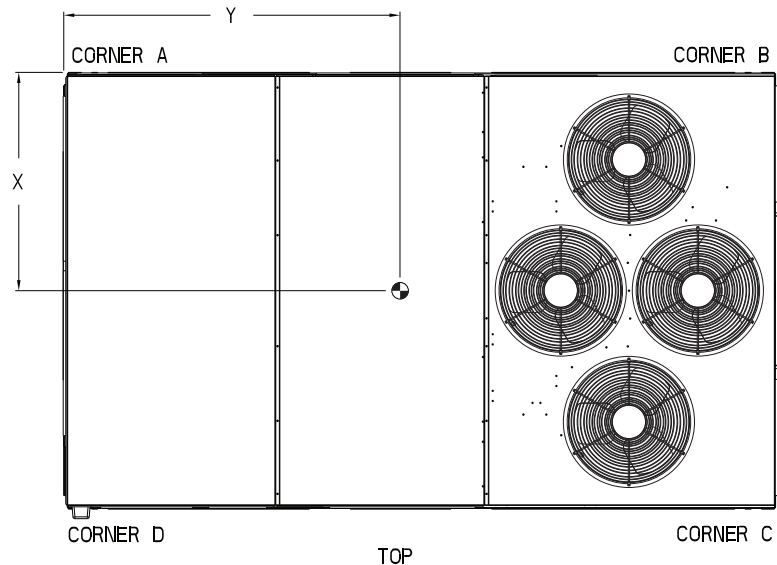

NOTES:

1. CLEARANCE ABOVE THE UNIT TO BE 72"
2. FOR ALL MINIMUM CLEARANCES LOCAL CODES OR JURISDICTIONS MAY PREVAIL.

SURFACE	CLEARANCE		OPERATING CLEARANCE
	SERVICE WITH CONDUCTIVE BARRIER	SERVICE WITH NONCONDUCTIVE BARRIER	
FRONT	48 [1219mm]	36 [914mm]	18 [457mm]
LEFT	48 [1219mm]	42 [1067mm]	18 [457mm]
BACK	42 [1067mm]	36 [914mm]	18 [457mm]
LEFT WITH HOOD	36 [914mm]	36 [914mm]	18 [457mm]
RIGHT	36 [914mm]	36 [914mm]	18 [457mm]
TOP	72 [1829mm]	72 [1829mm]	72 [1829mm]

ITC CLASSIFICATION	SHEET	DATE	SUPERCEDES	FCO 24,28 SINGLE ZONE ELECTRICAL HEAT PUMP	50HE006192	REV
U.S. ECCN:NSR	4 OF 5	11/03/22	8/30/22			A

Fig. 10 — 50FCQ*24-28 Corner Weights and Clearances



THIS DOCUMENT IS THE PROPERTY OF CARRIER CORPORATION AND IS DELIVERED UPON THE EXPRESS CONDITION THAT THE CONTENTS WILL NOT BE DISCLOSED OR USED WITHOUT CARRIER CORPORATION'S WRITTEN CONSENT.

SUBMISSION OF THESE DRAWINGS OR DOCUMENTS DOES NOT CONSTITUTE PART PERFORMANCE OR ACCEPTANCE OF CONTRACT.

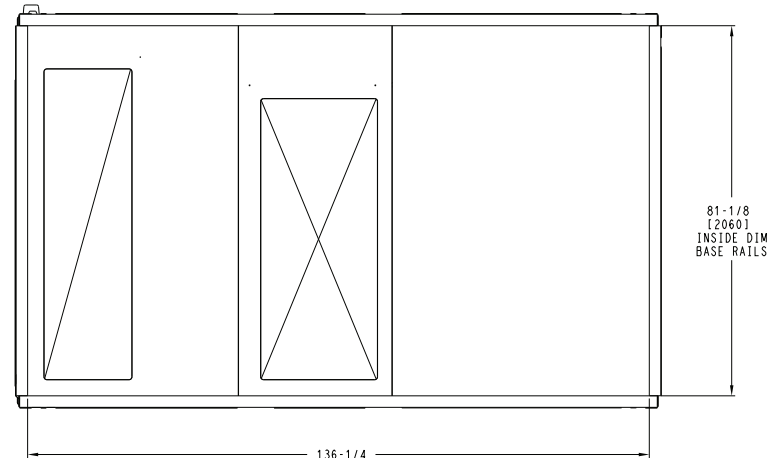
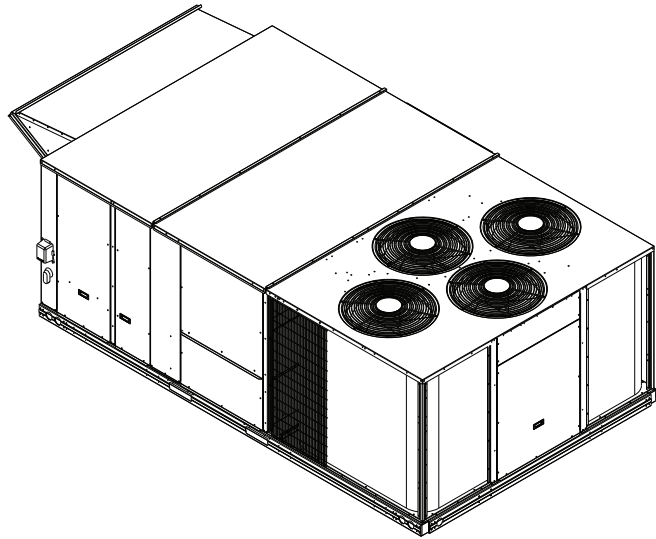

BOTTOM
INSIDE BASERAIL DIMENSIONS

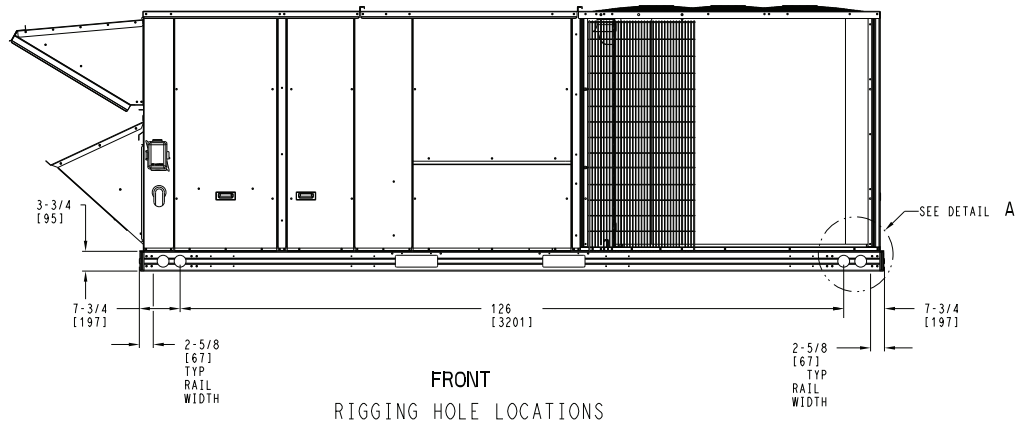

FRONT
RIGGING HOLE LOCATIONS

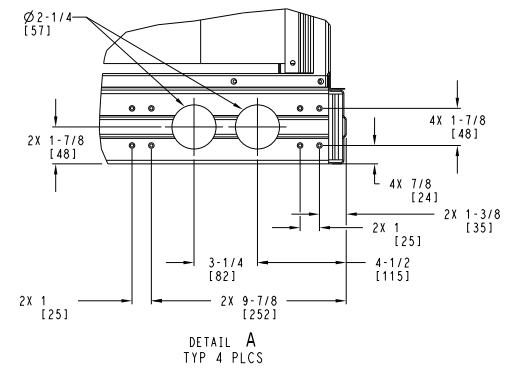

DETAIL A
TYP 4 PLCS

13

ITC CLASSIFICATION U.S. ECCN:NSR	SHEET 5 OF 5	DATE 11/03/22	SUPERCEDES -	FCO 24,28 SINGLE ZONE ELECTRICAL HEAT PUMP	50HE006192	REV A
-------------------------------------	-----------------	------------------	-----------------	---	------------	----------

Fig. 11 — 50FCQ*24-28 Bottom View

INSTALLATION

Job-Site Survey

Complete the following checks before installation.

1. Consult local building codes and the NEC (National Electrical Code) ANSI/NFPA 70 for special installation requirements.
2. Determine unit location (from project plans) or select unit location.
3. Check for possible overhead obstructions which may interfere with unit lifting or rigging.

Step 1 — Plan for Unit Location

Select a location for the unit and its support system (curb or other) that provides for the minimum clearances required for safety. This includes the clearance to combustible surfaces, unit performance and service access below, around and above unit as specified in the unit drawings. See Fig. 5 and 10.

NOTE: Consider also the effect of adjacent units.

Unit may be installed directly on wood flooring or on class A, B, or C roof-covering material when roof curb is used.

Do not install unit in an indoor location. Do not locate air inlets near exhaust vents or other sources of contaminated air.

Although unit is weatherproof, avoid locations that permit water from higher level runoff and overhangs to fall onto the unit.

Select a unit mounting system that provides adequate height to allow installation of condensate trap per requirements. Refer to Install External Condensate Trap and Line on page 21 for required trap dimensions.

ROOF MOUNT

Check building codes for weight distribution requirements. Unit operating weight is shown in Table 2.

Table 2 — Operating Weights

50FCQ*	UNITS LB (KG)		
	17	24	28
Base Unit	1627	2057	2125
Economizer	246 (112)	246 (112)	246 (112)
Powered Outlet	35 (16)	35 (16)	35 (16)
Curb			
14 in. (356 mm)	240 (109)	255 (116)	255 (116)
24 in. (610 mm)	340 (154)	355 (161)	355 (161)

Step 2 — Plan for Sequence of Unit Installation

The support method used for this unit will dictate different sequences for the steps of unit installation. For example, on curb-mounted units, some accessories must be installed on the unit before the unit is placed on the curb. Review the following for recommended sequences for installation steps.

CURB-MOUNTED INSTALLATION

1. Install curb
2. Install field-fabricated ductwork inside curb
3. Install accessory thru-base service connection package (affects curb and unit) (refer to accessory installation instructions for details)
4. Rig and place unit
5. Remove top skid
6. Install outdoor air hood
7. Install smoke detector tube
8. Install condensate line trap and piping

9. Make electrical connections
10. Install other accessories

PAD-MOUNTED INSTALLATION

1. Prepare pad and unit supports
2. Rig and place unit
3. Remove duct covers and top skid
4. Install smoke detector return air sensor tube
5. Install field-fabricated ductwork at unit duct openings
6. Install outdoor air hood
7. Install condensate line trap and piping
8. Make electrical connections
9. Install other accessories

FRAME-MOUNTED INSTALLATION

Frame-mounted applications generally follow the sequence for a curb installation. Adapt as required to suit specific installation plan.

Step 3 — Inspect Unit

Inspect unit for transportation damage. File any claim with transportation agency.

Confirm before installation of unit that voltage, amperage and circuit protection requirements listed on unit data plate agree with power supply provided.

On units with hinged panel option, check to be sure all latches are tight and in closed position.

Locate the carton containing the outside air hood parts in the rear blower assembly. Do not remove carton until unit has been rigged and located in final position.

Step 4 — Provide Unit Support

ROOF CURB MOUNT

Accessory roof curb details and dimensions are shown in Fig. 14 and 15. Assemble and install accessory roof curb in accordance with instructions shipped with the curb.

NOTE: The gasketing of the unit to the roof curb is critical for a watertight seal. Install gasket supplied with the roof curb as shown in Fig. 14 and 15. Improperly applied gasket can also result in air leaks and poor unit performance.

Curb should be level. This is necessary for unit drain to function properly. Unit leveling tolerances are shown in Fig. 12. Refer to Accessory Roof Curb Installation Instructions for additional information as required.

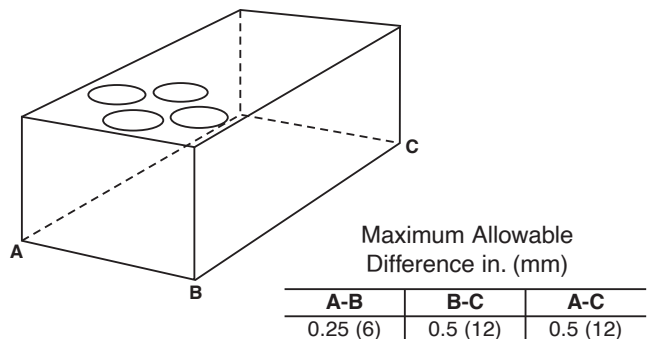

Fig. 12 — Unit Leveling Tolerances

Install insulation, cant strips, roofing felt, and counter flashing as shown. Ductwork must be attached to curb and not to the unit. Thru-the-base power connection must be installed before the unit is set on the roof curb.

If electric and control wiring is to be routed through the basepan, remove knockouts in basepan located in control box area of access panel, see Fig. 13. See Fig. 2, 3, 7 and 8 for basepan knockout locations for location. Attach the service connections to the basepan.

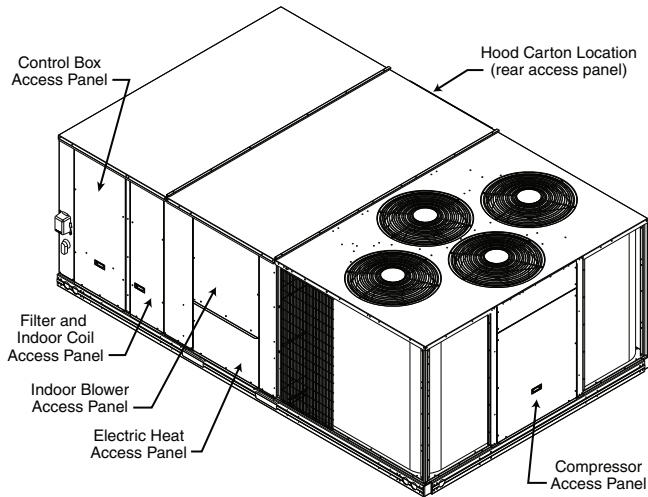

Fig. 13 — Typical Access Panel and Compressor Locations

SLAB MOUNT (HORIZONTAL UNITS ONLY)

Provide a level concrete slab that extends a minimum of 6 in. (150 mm) beyond unit cabinet. Install a gravel apron in front of condenser coil air inlet to prevent grass and foliage from obstructing airflow.

NOTE: Horizontal units may be installed on a roof curb if required.

ALTERNATE UNIT SUPPORT (IN LIEU OF CURB MOUNT)

A non-combustible sleeper rail can be used in the unit curb support area. If sleeper rails cannot be used, support the long sides of the unit with a minimum of 4 equally spaced 4 in. x 4 in. (102 mm x 102 mm) pads on each side. Locate pads so that they support the rails. Make sure to avoid the fork openings.

"A"	ROOF CURB ACCESSORY
1'-2" [356.0]	CRRFCURB045A00
2'-0" [610.0]	CRRFCURB046A00

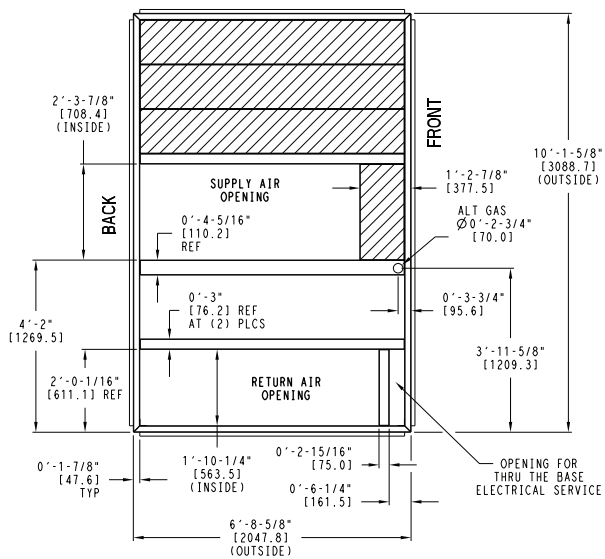

- NOTES:
- 1 ROOF CURB ACCESSORY IS SHIPPED UNASSEMBLED.
 - 2 DIMENSIONS IN [] ARE IN MILLIMETERS.
 - 3 ROOF CURB GALVANIZED STEEL.
 - 4 ATTACH DUCTWORK TO CURB (FLANGES ON DUCT REST ON CURB)
 - 5 SERVICE CLEARANCE 4 FT ON EACH SIDE

➔ DIRECTION OF AIR FLOW

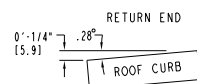
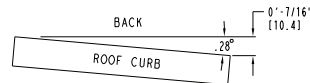

MAX CURB LEVELING TOLERANCES

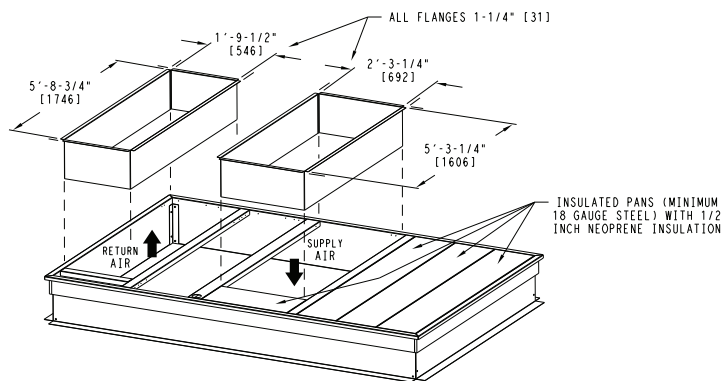
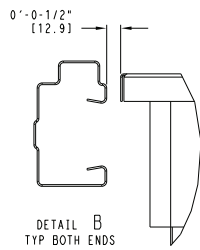
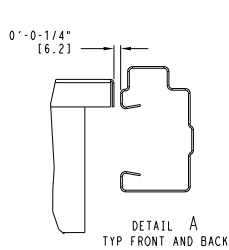
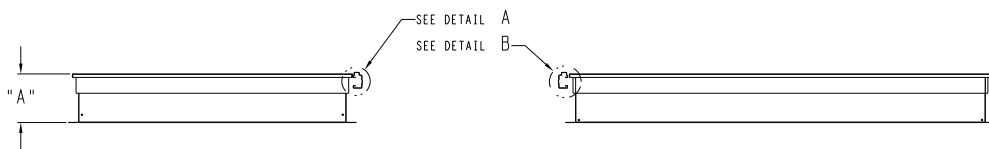
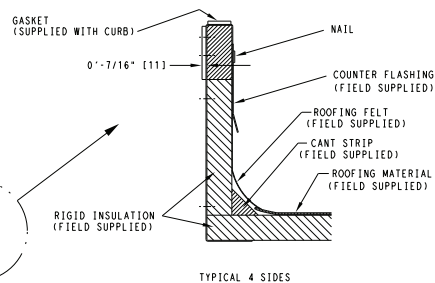
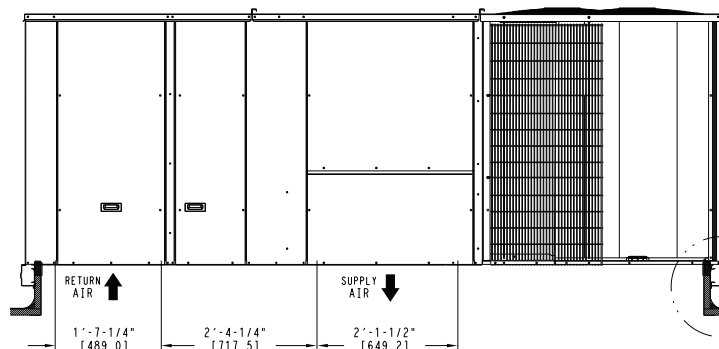
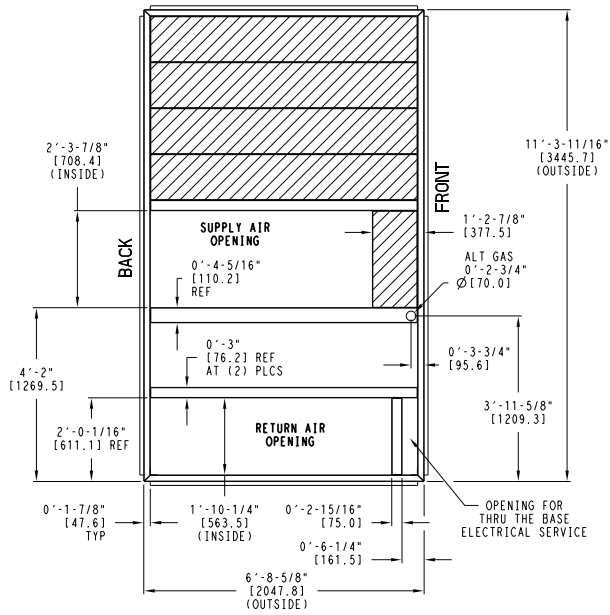

Fig. 14 — Roof Curb Details — Size 17 Units

"A"	ROOF CURB ACCESSORY
1'-2" [356.0]	CRRFCURB047A00
2'-0" [610.0]	CRRFCURB048A00



- NOTES:
- 1 ROOF CURB ACCESSORY IS SHIPPED UNASSEMBLED.
 - 2 DIMENSIONS IN [] ARE IN MILLIMETERS.
 - 3 ROOF CURB GALVANIZED STEEL.
 - 4 ATTACH DUCTWORK TO CURB (FLANGES ON DUCT REST ON CURB)
 - 5 SERVICE CLEARANCE 4 FT ON EACH SIDE

➔ DIRECTION OF AIR FLOW

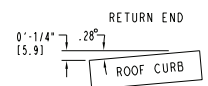
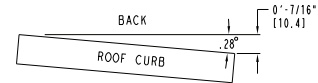

MAX CURB LEVELING TOLERANCES

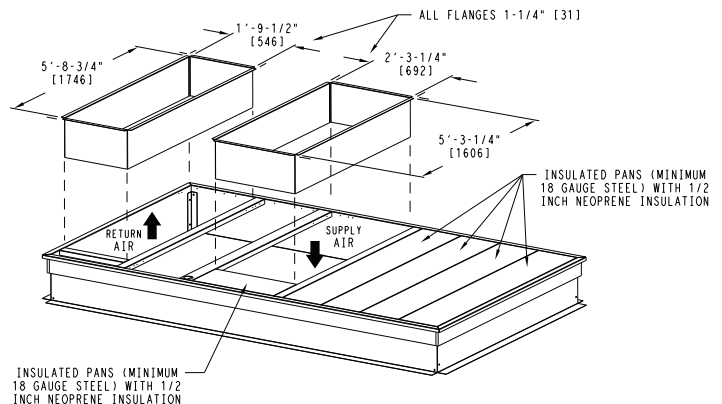
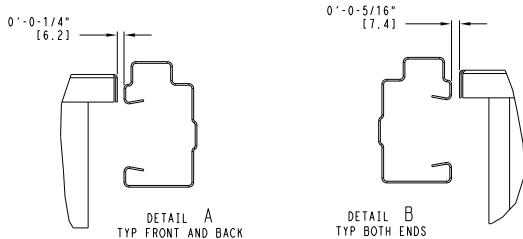
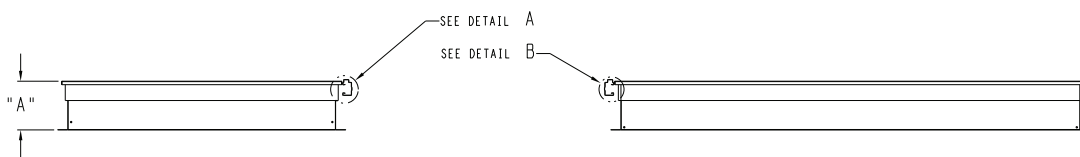
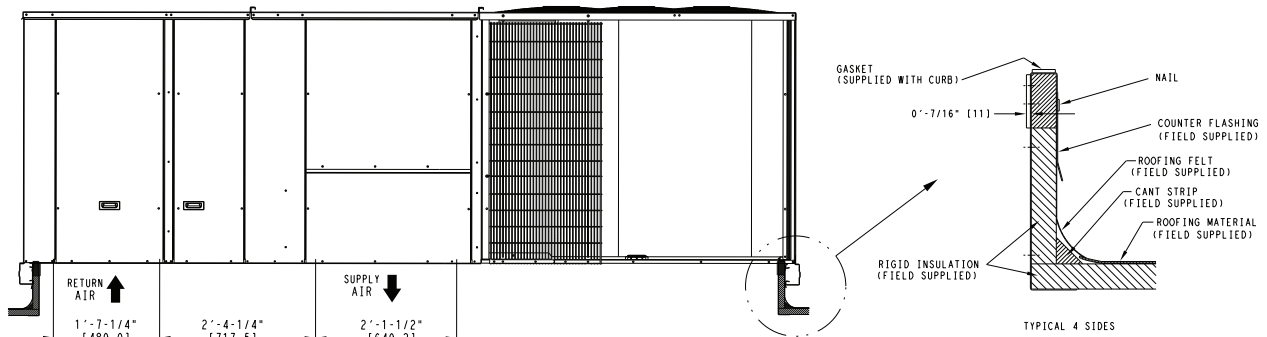

Fig. 15 — Roof Curb Details — Size 24 and 28 Units

Step 5 — Field Fabricate Ductwork

Cabinet return-air static pressure (a negative condition) shall not exceed 0.5 in. wg (87 Pa) with economizer or without economizer.

For vertical ducted applications, secure all ducts to roof curb and building structure. Do not connect ductwork to unit.

Fabricate supply ductwork so that the cross sectional dimensions are equal to or greater than the unit supply duct opening dimensions for the first 18 in. (458 mm) of duct length from the unit basepan.

Insulate and weatherproof all external ductwork, joints, and roof openings with counter flashing and mastic in accordance with applicable codes.

Ducts passing through unconditioned spaces must be insulated and covered with a vapor barrier.

If a plenum return is used on a vertical unit, the return should be ducted through the roof deck to comply with applicable fire codes.

⚠ CAUTION

PROPERTY DAMAGE HAZARD

Failure to follow this caution may result in damage to roofing materials.

Membrane roofs can be cut by sharp sheet metal edges. Be careful when placing any sheet metal parts on such roof.

FOR UNITS WITH ACCESSORY ELECTRIC HEATERS

A minimum clearance is not required around ductwork.

⚠ WARNING

PERSONAL INJURY HAZARD

Failure to follow this warning could cause personal injury.

For vertical supply and return units, tools or parts could drop into ductwork and cause an injury. Install a 90 degree turn in the return ductwork between the unit and the conditioned space. If a 90 degree elbow cannot be installed, then a grille of sufficient strength and density should be installed to prevent objects from falling into the conditioned space. Due to electric heater, supply duct will require 90 degree elbow.

Step 6 — Rig and Place Unit

Keep unit upright and do not drop. Spreader bars are not required if top crating is left on the unit. Rollers may be used to move unit across a roof. Level by using unit frame as a reference. See Table 2 and Fig. 16 for additional information.

Lifting holes are provided in base rails as shown in Fig. 16. Refer to rigging instructions on the unit.

⚠ CAUTION

UNIT DAMAGE HAZARD

Failure to follow this caution may result in equipment damage.

All panels must be in place when rigging. Unit is not designed for handling by fork truck when packaging is removed.

If using top crate as spreader bar, once unit is set, carefully lower wooden crate off building roof top to ground. Ensure that no people or obstructions are below prior to lowering the crate.

Before setting the unit onto the curb, recheck gasketing on curb.

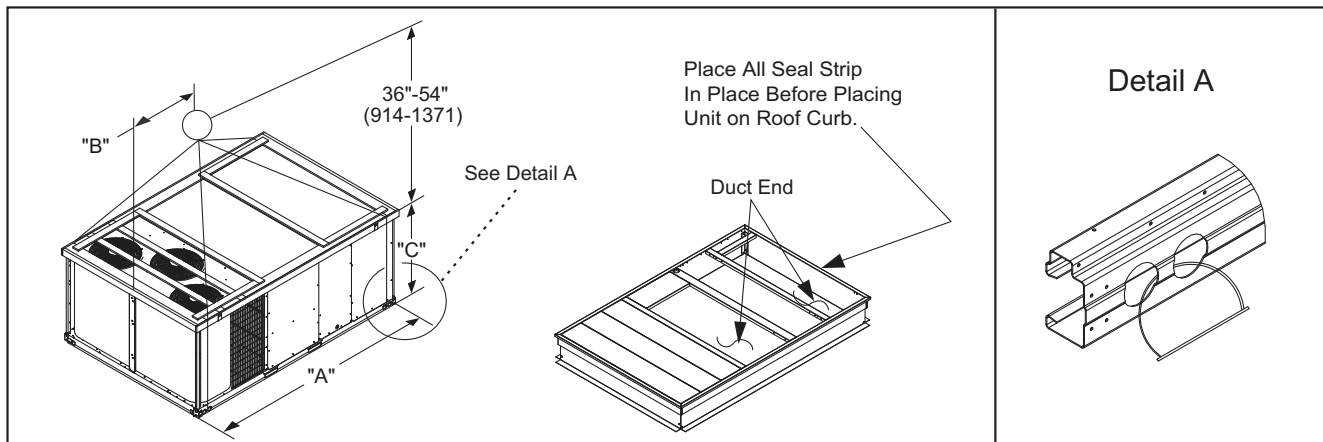

UNIT	MAX WEIGHT		DIMENSIONS					
			A		B		C	
	lb	kg	in.	mm	in.	mm	in.	mm
50FCQ*17	2748	1246	127.8	3245	72.0	1830	52.5	1335
50FCQ*24	3331	1511	141.5	3595	75.5	1920	60.5	1535
50FCQ*28	3399	1542	141.5	3595	77.0	1955	60.5	1535

NOTES:

- Dimensions in () are in millimeters.
- Hook rigging shackles through holes in base rail, as shown in detail "A." Holes in base rails are centered around the unit center of gravity. Use wooden top to prevent rigging straps from damaging unit.

Fig. 16 — Rigging Details

POSITIONING ON CURB

Position unit on roof curb so that the following clearances are maintained: 1/4 in. (6 mm) clearance between the roof curb and the base rail inside the right and left, 1/2 in. (12 mm) clearance between the roof curb and the base rail inside the front and back. This will result in the distance between the roof curb and the base rail being approximately equal to Details A and B in Fig. 14 and 15.

Do not attempt to slide unit on curb after unit is set. Doing so will result in damage to the roof curb seal.

Although unit is weatherproof, guard against water from higher level runoff and overhangs.

After unit is in position, remove rigging skids and shipping materials.

Step 7 — Horizontal Duct Connection

Depending on the unit size, see either Fig. 3 and 4 (size 17) or Fig. 8 and 9 (sizes 24 and 28) for locations and sizes of the horizontal duct connections. Note that there are 2 different return air duct connection locations – one for unit without an economizer (on back side of unit) and a different one for unit equipped with an economizer (on left end, under the economizer hood). The supply air duct connection is on the back side. See Fig. 17 for top view depicting typical horizontal duct arrangements.

NOTE: 50FCQ size 17 to 28 units are factory assembled as either dedicated horizontal or vertical units. These units cannot be field converted.

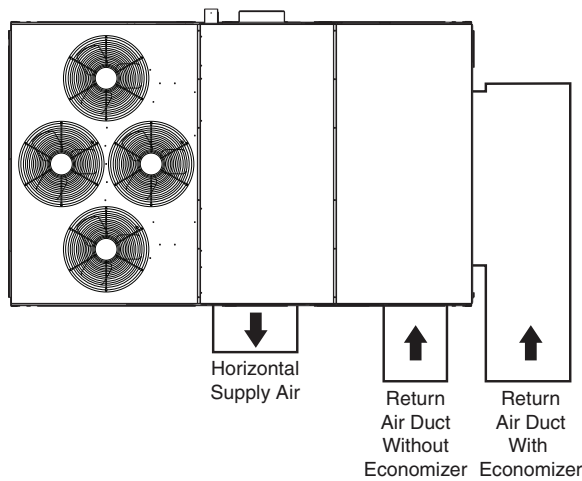

LOCATION	SUPPLY	RETURN WITHOUT ECONOMIZER	RETURN WITH ECONOMIZER
	Back	Back	Left End
Height - in. (mm)	15-7/8 (402)	49-3/8 (1253)	18-3/8 (467)
Width - in. (mm)	29-3/4 (756)	23-3/8 (593)	61-5/8 (1564)

Fig. 17 — Horizontal Duct Opening Dimensions

Field-supplied (3/4 in.) flanges should be attached to horizontal duct openings (see Fig. 17) and all ductwork should be secured to the flanges. Insulate and weatherproof all external ductwork, joints, and roof or building openings with counter flashing and mastic in accordance with applicable codes.

Step 8 — Install Outside Air Hood (Factory Option)

The outside air hood for factory-option economizer and two-position damper is shipped in knock-down form and requires field assembly. The panel for the hood top is shipped on the end of the unit (see Fig. 18). The remaining parts for the hood assembly (including side panels, filters and tracks) are shipped in a carton that is secured to the rear of the blower assembly. Access the carton location through rear panel (see Fig. 19).

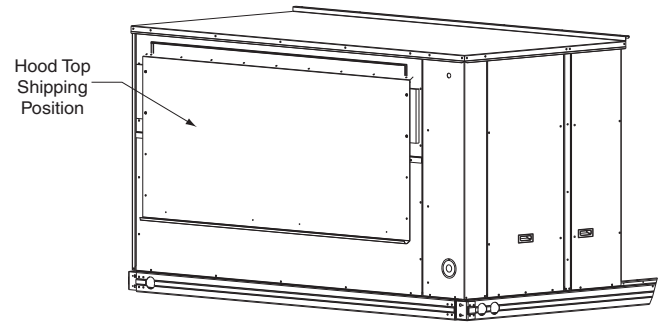

Fig. 18 — Hood Top — Shipping Position

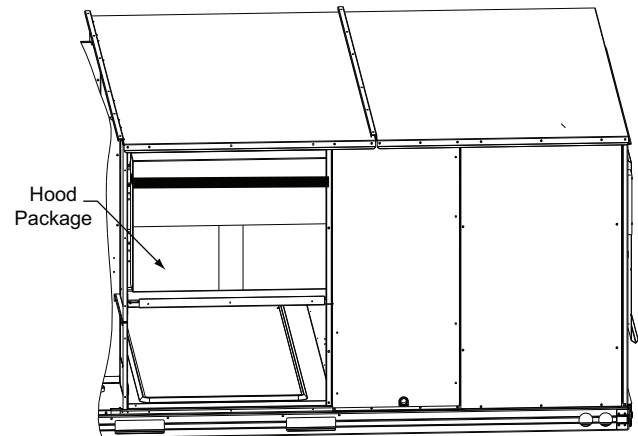

Fig. 19 — Hood Package — Shipping Location

To remove the hood parts package:

1. Remove the back blower access panel.
2. Locate and cut the strap, being careful to not damage any wiring.
3. Carefully lift the hood package carton through the back blower access opening.

To assemble the outside air hood (see Fig. 20 for hood component locations):

1. Remove hood top panel from shipping position on unit end.
2. Install filter supports (Item #1) to the upper end panel using the screws provided.
3. Install each deflector (Item #8) on to each filter support (Item #1) using the screws provided.
4. Apply seal strip to mating flanges on side panels of hood (Items #4 and #5).
5. Secure side panels (Items #4 and #5) to upper panel using the screws provided.
6. Apply seal strip to mating flange of the hood (see Fig. 20).
7. Secure hood top (Item #3) to upper panel using the screws provided. (On 44-in. chassis, remove the screws from across top cover of unit. The rear flange of hood top will slide behind unit top over flange.)
8. Secure side retainers (Item #6) to side panels (Items #4 and #5) using the screws provided, screwing from outside of the hood.
9. Secure each central retainer (Item #2) to the hood top (Item #3). Then align central retainers to holes located on filter support (Item #1), so central retainer is perpendicular to hood and each filter support. Secure using screws provided.
10. Apply seal strip to top diverters (Item #7).
11. Secure top diverters (Item #7) to hood top (Item #3).

12. Install outdoor air screens by sliding them into each of the four spaces created by the hood, filter support and central retainers. To do so, first insert the air screens into pocket created at the end of hood (Item #3), then fully put the air screen into place, and then slide them back into pocket created in the filter support (Item #1). Repeat this for each air screen (see Fig. 21). See Fig. 22 for completed hood assembly.

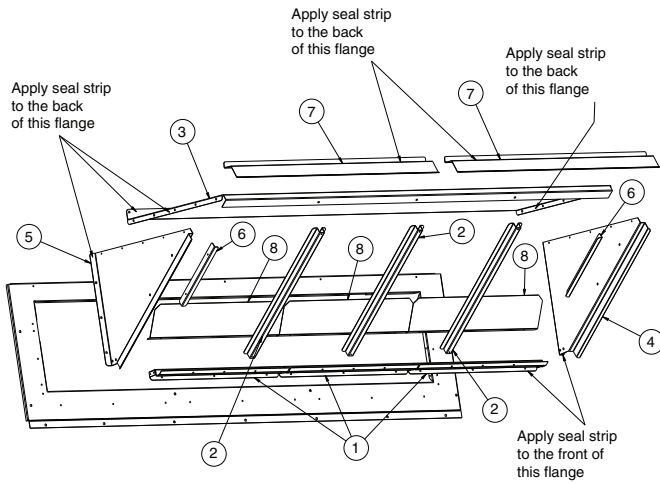

ITEM #	DESCRIPTION	QTY
1	Filter Supports	3
2	Central Retainer	3
3	Hood Top	1
4	Left Hood Side	1
5	Right Hood Side	1
6	Side Retainer	2
7	Top Diverters	2
8	Deflector	3

Fig. 20 — Hood Part Identification and Seal Strip Application Areas

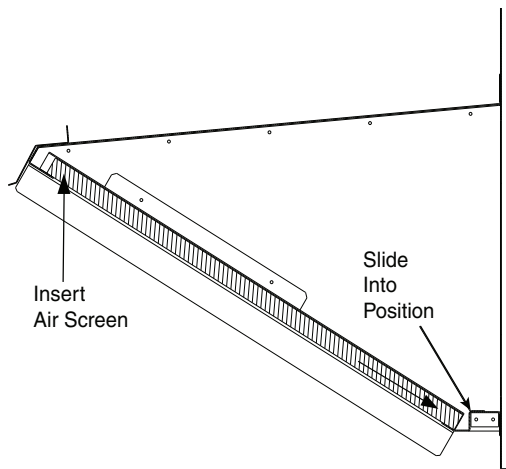

Fig. 21 — Outdoor Air Screen Installation

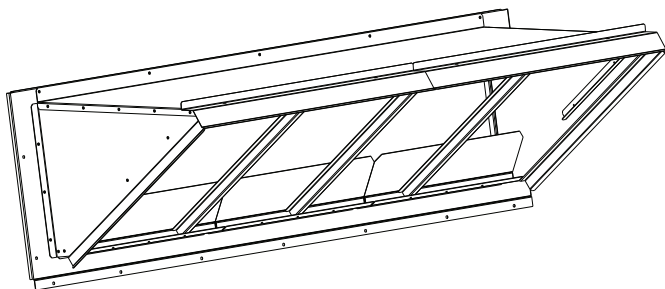

Fig. 22 — Completed Hood Assembly

Step 9 — Assemble Barometric Hood

The barometric hood can be assembled in vertical or horizontal configuration. Figure 23 illustrates the barometric hood parts.

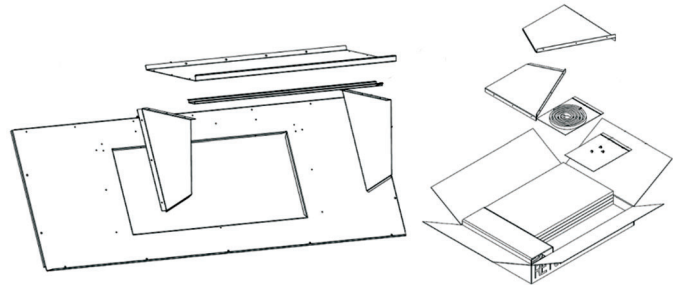

Fig. 23 — Barometric Hood Parts

BAROMETRIC HOOD (VERTICAL CONFIGURATION)

1. Remove the hood top panel from its shipping position on the unit end (see Fig. 24).

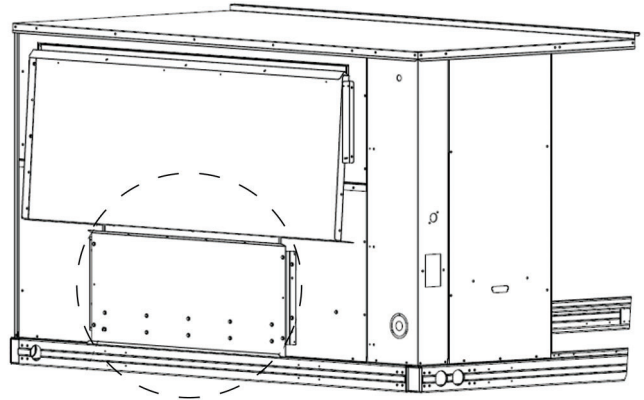

Fig. 24 — Shipping Location, Vertical Units

2. Remove the side panels located in the hood parts box (see Fig. 25).

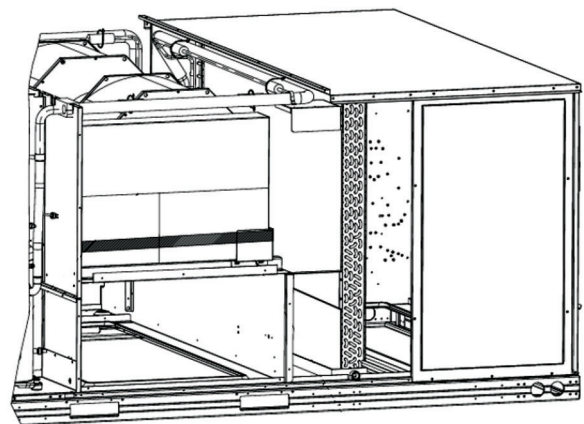

Fig. 25 — Barometric Hood Box Parts Location

3. Install parts as shown in the following exploded view (see Fig. 26) using the seal strip and screws provided in the parts box.

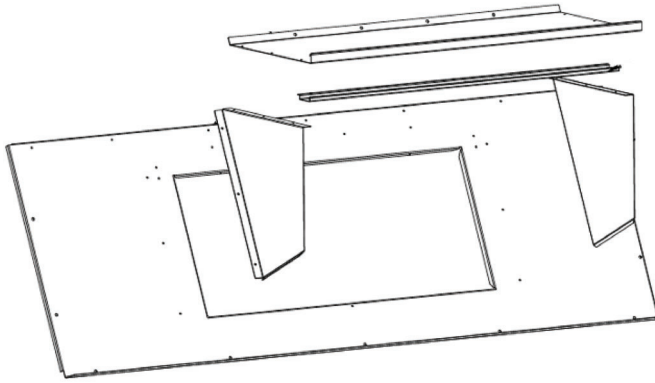

Fig. 26 — Barometric Hood Exploded View

Figure 27 illustrates the installed barometric hood parts.

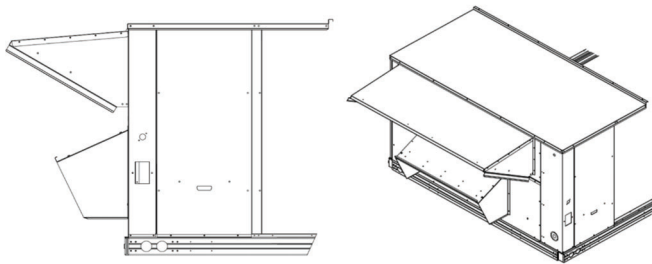

Fig. 27 — Installed Barometric Hood Side View and Isometric View

BAROMETRIC HOOD (HORIZONTAL CONFIGURATION)

For horizontal return and field installed economizer, install the economizer as follows:

1. Install the field provided horizontal ductwork onto the unit. Duct height must be at least 19-1/2 in. high, however the duct can be no taller than the top of the relief opening in the bottom panel, or airflow into the outside air hood will be restricted. See Fig. 28.

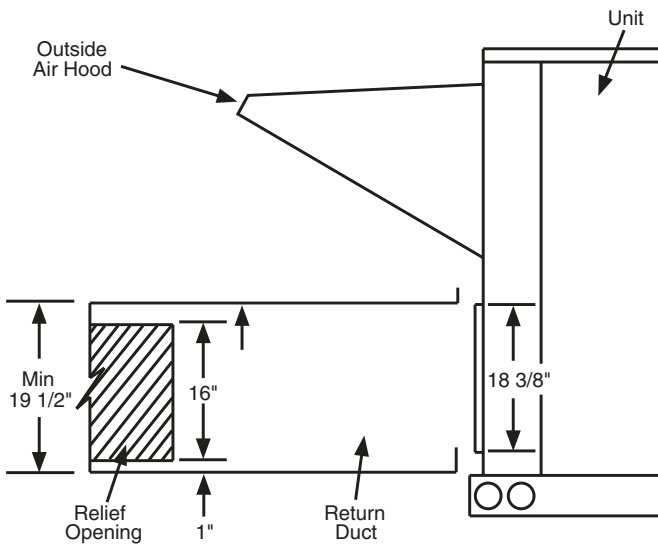

Fig. 28 — Relief Damper

2. Cut a 16 in. x 36 in. opening in the return duct for the relief damper (see Fig. 28).
3. On the field installed economizer (CRECOMZR0**A00), a birdscreen or hardware cloth is shipped attached to the bottom panel used for vertical applications.

NOTE: This panel is not used for horizontal return applications. Remove the screen from the provided panel and install it over the relief opening cut in return duct.

4. Using the blade brackets, install the relief damper onto the side of the return duct (see Fig. 29). The two brackets and relief damper are provided with the economizer.

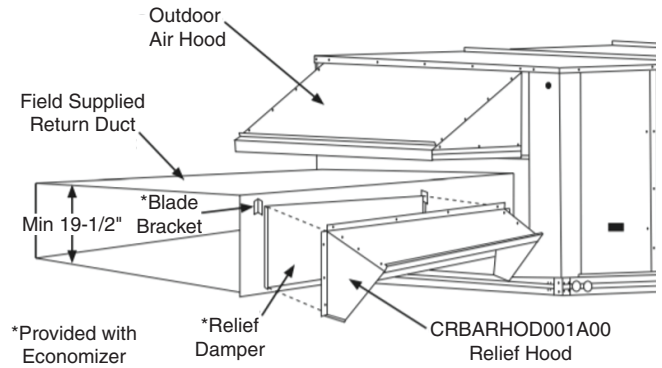

Fig. 29 — Installing CRBARHOD001A00 Over Relief Damper

5. Using the provided hardware, screw the CRBARHOD001A00 hood sides and top together (see Fig. 30).

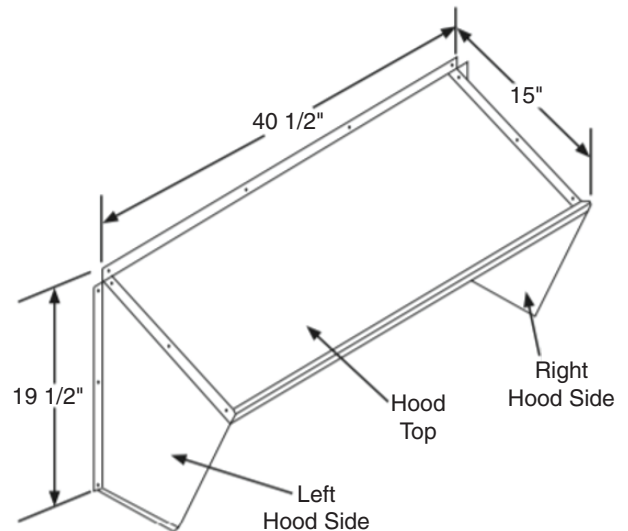

Fig. 30 — CRBARHOD001A00 Hood Sides and Top

Caulk the backside of the mating flanges to ensure a watertight seal. Install the CRBARHOD001A00 over the relief damper and screw to the return duct, as illustrated in Fig. 29.

Step 10 — Install External Condensate Trap and Line

The unit has one 3/4 in. condensate drain connection on the end of the condensate pan (see Fig. 31). See Fig. 4 and 9 for the location of the condensate drain connection.

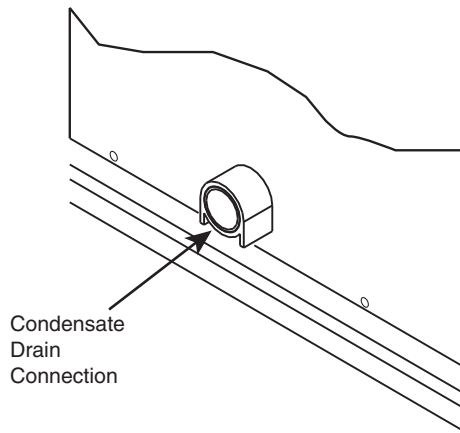
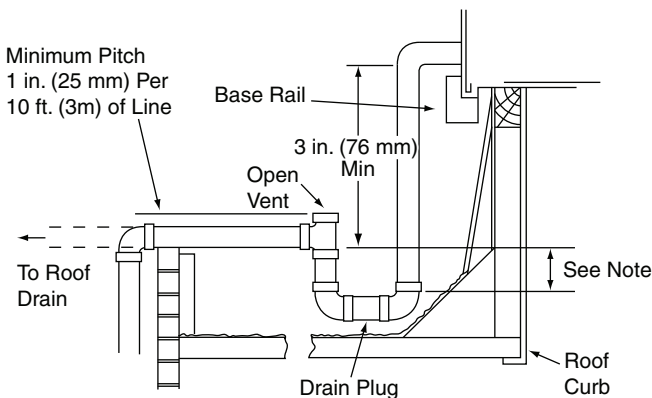

Fig. 31 — Condensate Drain Pan Connection

The piping for the condensate drain and external trap can be completed after the unit is in place. Hand tighten fittings to the drain pan fitting. Provide adequate support for the drain line. Failure to do so can result in damage to the drain pan. See Fig. 32.



NOTE: Trap should be deep enough to offset maximum unit static difference. A 4 in. (102 mm) trap is recommended.

Fig. 32 — Condensate Drain Piping Details

All units must have an external trap for condensate drainage. Install a trap at least 4 in. (102 mm) deep and protect against freeze-up. If drain line is installed downstream from the external trap, pitch the line away from the unit at 1 in. per 10 ft (25 mm in 3 m) of run. Do not use a pipe size smaller than the unit connection (3/4 in.).

Step 11 — Make Electrical Connections

⚠ WARNING

ELECTRIC SHOCK HAZARD

Failure to follow this warning could result in personal injury or death.

Unit cabinet must have an uninterrupted, unbroken electrical ground to minimize the possibility of personal injury if an electrical fault should occur. This ground may consist of electrical wire connected to unit ground lug in control compartment, or conduit approved for electrical ground when installed in accordance with NEC; ANSI/NFPA 70, latest edition (in Canada, Canadian Electrical Code CSA [Canadian Standards Association] C22.1), and local electrical codes.

NOTE: Field-supplied wiring shall conform with the limitations of minimum 63°F (33°C) rise.

FIELD POWER SUPPLY

If equipped with optional powered convenience outlet: the power source leads to the convenience outlet's transformer primary are not factory connected. Installer must connect these leads according to required operation of the convenience outlet. If an always-energized convenience outlet operation is desired, connect the source leads to the line side of the unit-mounted disconnect. (Check with local codes to ensure this method is acceptable in your area.) If a de-energize via unit disconnect switch operation of the convenience outlet is desired, connect the source leads to the load side of the unit disconnect. On a unit without a unit-mounted disconnect, connect the source leads to the line side with unit field power leads. See Fig. 33.

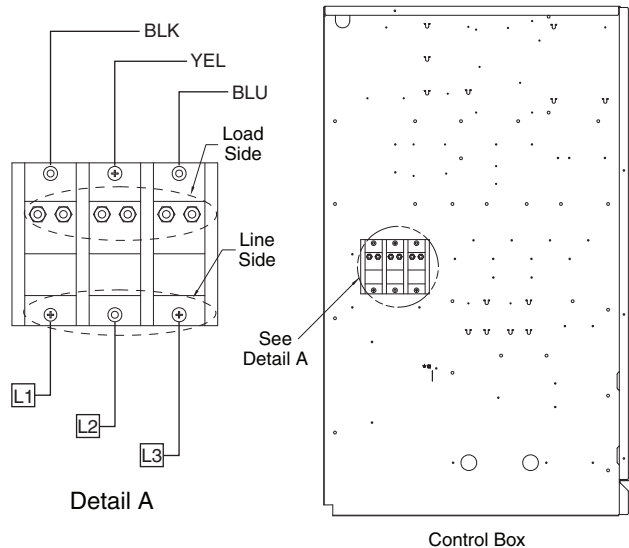

Fig. 33 — Location of TB1

Field power wires are connected to the unit at line-side pressure lugs on the terminal block (see wiring diagram label for control box component arrangement) or at factory-installed option non-fused disconnect switch. Use copper conductors only. See Fig. 34.

NOTE: Make field power connections directly to line connection pressure lugs only.

⚠ WARNING

FIRE HAZARD

Failure to follow this warning could result in personal injury, death, or property damage.

Do not connect aluminum wire between disconnect switch and unit. Use only copper wire.

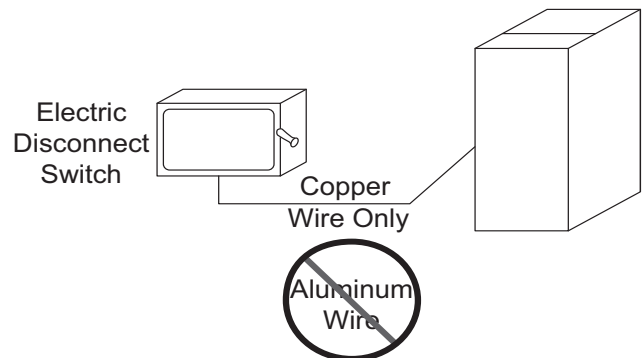

Fig. 34 — Disconnect Switch and Unit

UNITS WITHOUT FACTORY-INSTALLED NON-FUSED DISCONNECT

When installing units, provide a disconnect switch per NEC (National Electrical Code) of adequate size. Disconnect sizing data is provided on the unit informative plate. Locate on unit cabinet or within sight of the unit per national or local codes. Do not cover unit informative plate if mounting the disconnect on the unit cabinet.

UNITS WITH FACTORY-INSTALLED NON-FUSED DISCONNECT

The factory-installed option non-fused disconnect switch (NFD) is located in the main control box. The manual switch handle and shaft are shipped in the control box and must be mounted on the corner post adjacent to the control box (see Fig. 35). Note that the tape covering the hole for the shaft in the corner post must be removed prior to handle and shaft installation.

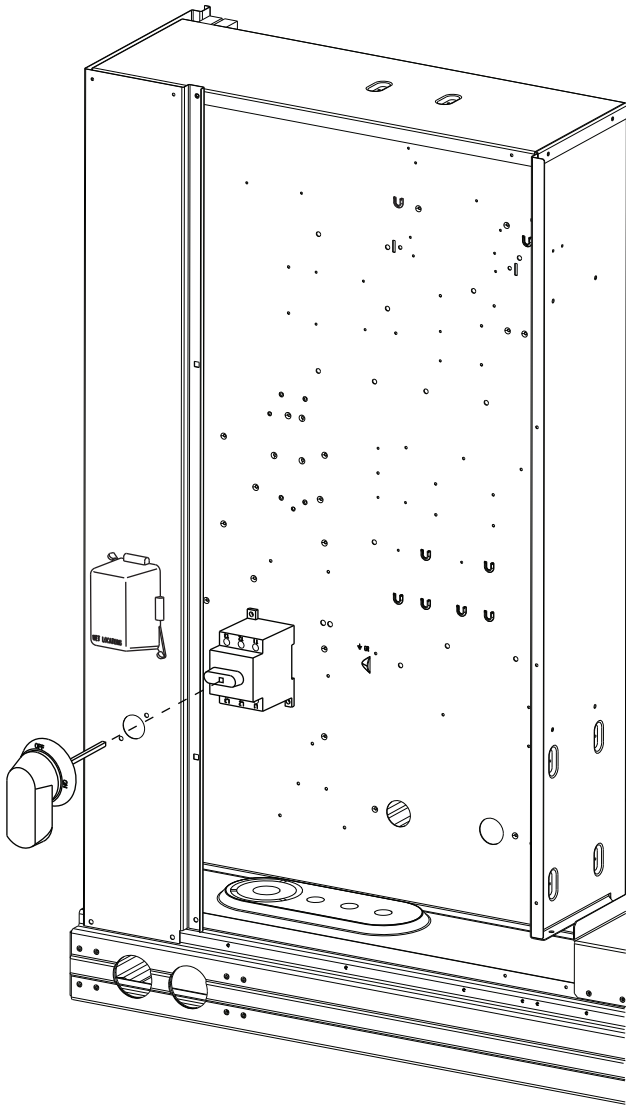

Fig. 35 — Handle and Shaft Assembly for NFD

To field install the NFD shaft and handle:

1. Open the control box panel.
2. Make sure the NFD shipped from the factory is at OFF position (the arrow on the black handle knob or on the silver metal collar is at OFF).
3. Insert the shaft with the cross pin on the top of the shaft in the horizontal position.

4. Measure the tip of the shaft to the outside surface of the corner post to be 0.88 in.
5. Tighten the locking screw to secure the shaft to the NFD.
6. Turn the handle to OFF position with red arrow pointing at OFF.
7. Install the handle on to the corner post vertically with the red arrow pointing up.
8. Secure the handle to the corner post with (2) screws and lock washers supplied.

ALL UNITS

All field wiring must comply with NEC and all local code requirements.

Size wire based on MCA (Minimum Circuit Amps) on the unit informative plate. See Fig. 36 for power wiring connections to the unit power terminal block and equipment ground. Maximum wire size is 2/0 AWG per pole.

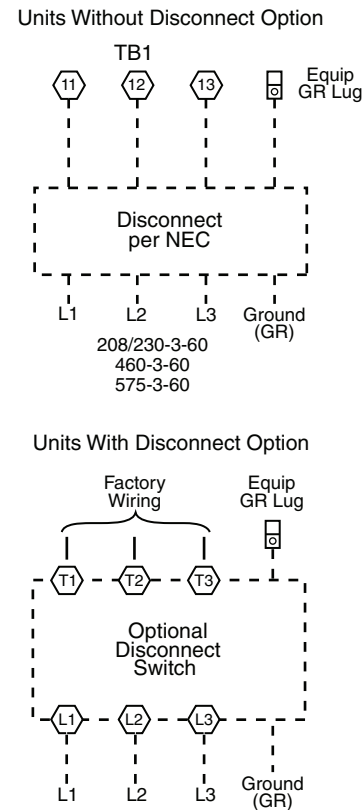

Fig. 36 — Power Wiring Connections

Provide a ground-fault and short-circuit over-current protection device (fuse or breaker) per NEC Article 440 (or local codes). Refer to unit informative data plate for MOCP (Maximum Over-current Protection) device size.

Voltage to compressor terminals during operation must be within voltage range indicated on unit nameplate. On 3-phase units, voltages between phases must be balanced within 2% and the current within 10%. Use the following formula to determine the percent of voltage imbalance.

$$\% \text{ Voltage Imbalance} = 100 \times \frac{\text{max voltage deviation from average voltage}}{\text{average voltage}}$$

Example: Supply voltage is 230-3-60

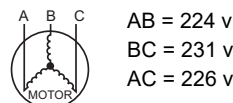

$$\text{Average Voltage} = \frac{(224 + 231 + 226)}{3} = \frac{681}{3} = 227$$

Determine maximum deviation from average voltage.

(AB) 227-224 = 3 v

(BC) 231-227 = 4 v

(AC) 227-226 = 1 v

Maximum deviation is 4 v.

Determine percent of voltage imbalance.

$$\% \text{ Voltage Imbalance} = 100 \times \frac{4}{227} = 1.78\%$$

This amount of phase imbalance is satisfactory as it is below the maximum allowable 2%.

IMPORTANT: If the supply voltage phase imbalance is more than 2%, contact your local electric utility company immediately.

⚠ CAUTION

UNIT DAMAGE HAZARD
Failure to follow this caution may result in equipment damage. Operation on improper line voltage or excessive phase imbalance constitutes abuse and may cause damage to electrical components. Such operation would invalidate any applicable Carrier warranty.

CONVENIENCE OUTLETS

⚠ WARNING

ELECTRICAL OPERATION HAZARD
Failure to follow this warning could result in personal injury or death. Units with convenience outlet circuits may use multiple disconnects. Check convenience outlet for power status before opening unit for service. Locate its disconnect switch, if appropriate, and open it. Lock-out and tag-out this switch, if necessary.

Two types of convenience outlets are offered on 50FCQ models: non-unit powered and unit-powered. Both types provide a 125-v GFCI (ground-fault circuit-interrupter) duplex receptacle rated at 15-A behind a hinged access cover, located on the corner panel of the unit. See Fig. 37.

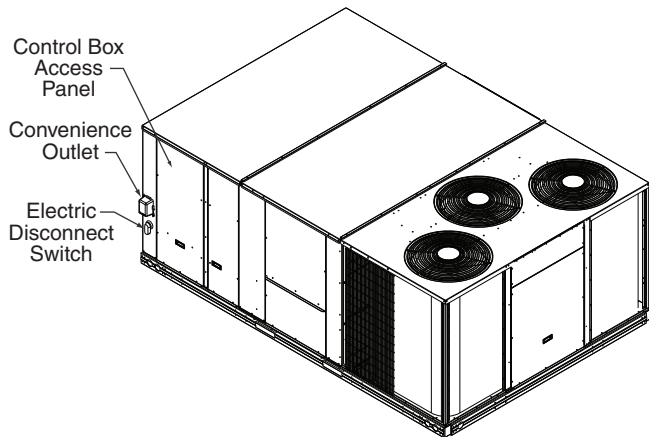

Fig. 37 — Convenience Outlet Location

Installing Weatherproof Cover

A weatherproof while-in-use cover for the factory-installed convenience outlets is now required by UL standards. This cover cannot be factory-mounted due to its depth; it must be installed at unit installation. For shipment, the convenience outlet is covered with a blank cover plate.

The weatherproof cover kit is shipped in the unit's control box. The kit includes the hinged cover, a backing plate and gasket.

DISCONNECT ALL POWER TO UNIT AND CONVENIENCE OUTLET. LOCK-OUT AND TAG-OUT ALL POWER.

Remove the blank cover plate at the convenience outlet; discard the blank cover.

Loosen the two screws at the GFCI duplex outlet, until approximately 1/2 in. (13 mm) under screw heads are exposed. Press the gasket over the screw heads. Slip the backing plate over the screw heads at the keyhole slots and align with the gasket; tighten the two screws until snug (do not over-tighten).

Mount the weatherproof cover to the backing plate as shown in Fig. 38. Remove two slot fillers in the bottom of the cover to permit service tool cords to exit the cover. Check for full closing and latching.

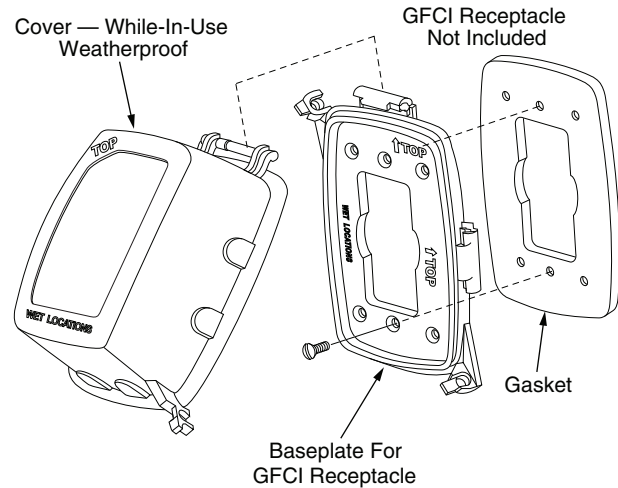

Fig. 38 — Weatherproof Cover Installation

Non unit-powered type

Requires the field installation of a general-purpose 125-v 15-A circuit powered from a source elsewhere in the building. Observe national and local codes when selecting wire size, fuse or breaker requirements and disconnect switch size and location. Route 125-v power supply conductors into the bottom of the utility box containing the duplex receptacle.

Unit-powered type

A unit-mounted transformer which is factory-installed to step-down the main power supply voltage to the unit to 115-v at the duplex receptacle. This option also includes a manual switch with fuse, located in a utility box and mounted on a bracket behind the convenience outlet; access is through the unit's control box panel. See Fig. 39.

The primary leads to the convenience outlet transformer are not factory-connected. If local codes permit, the transformer primary leads can be connected at the line-side terminals on the unit-mounted non-fused disconnect switch; this will provide service power to the unit when the unit disconnect switch is open. See Fig. 39. See Fig. 40 for convenience outlet utilization precautions.

Test the GFCI receptacle by pressing the TEST button on the face of the receptacle to trip and open the receptacle. Check for proper grounding wires and power line phasing if the GFCI receptacle does not trip as required. Press the RESET button to clear the tripped condition.

Using unit-mounted convenience outlets: Units with unit-mounted convenience outlet circuits will often require that two disconnects be opened to de-energize all power to the unit. Treat all units as electrically energized until the convenience outlet power is also checked and de-energization is confirmed. Observe National Electrical Code Article 210, Branch Circuits, for use of convenience outlets.

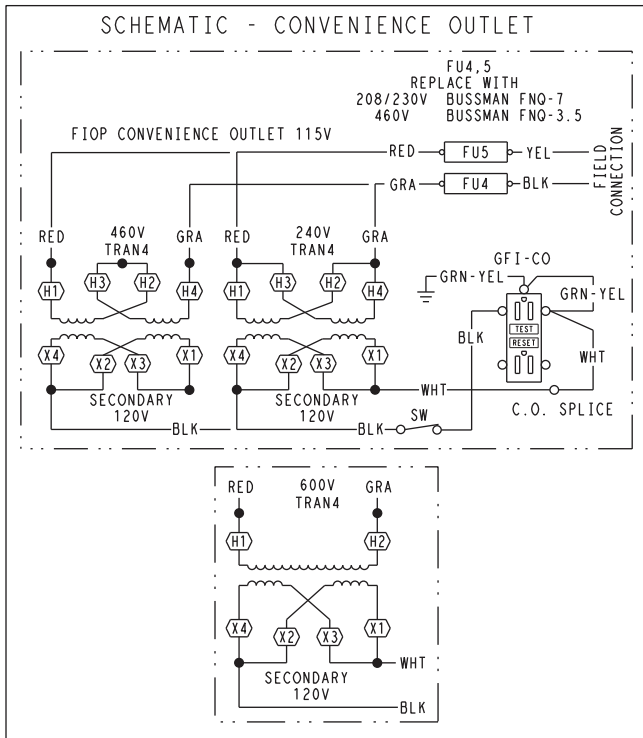

UNIT VOLTAGE	CONNECT AS	PRIMARY CONNECTIONS	TRANSFORMER TERMINALS
208, 230	240	L1: RED+YEL L2: BLU+GRA	H1+H3 H2+H4
460	480	L1: RED Splice BLU+YEL L2: GRA	H1 H2+H3 H4
575	600	L1: RED L2: GRA	H1 H2

Fig. 39 — Powered Convenience Outlet Wiring

NOTICE/AVIS

Convenience Outlet Utilization

Maximum Intermittent Use 15 - Amps
Maximum Continuous Use 8 - Amps
Observe a 50% limit on the circuit
Loading above 8 - Amps

Utilisation de la prise utilitaire

Usage intermittent maximum 15 - Amps
Usage continu maximum 8 - Amps
Observez une limite de 50% sur le circuit
Chargement au-dessus de 8 - Amps

50HE501288 | 2.0

Fig. 40 — Convenience Outlet Utilization Notice

FACTORY-OPTION THRU-BASE CONNECTIONS

All units are equipped with the ability to bring utilities through the base.

The electrical entrance is located in the control box area and can be accessed through the control box access panel. An embossed area is provided with three knock outs. High voltage is brought through the multi knock out by removing the appropriate size for the size of the fitting required. A 7/8 in. knock out is provided for low voltage. An additional 7/8 in. knock out is provided for a 115-v line which is used when the unit is equipped with the non-unit powered convenience outlet option.

All required fittings are field supplied. Install fittings when access to both top and bottom of the base pan is available.

Units Without Thru-Base Connections

1. Install liquid tight conduit between disconnect and control box.
2. Pull correctly rated high voltage wires through the conduit.
3. Install power lines to terminal connections as shown in Fig. 36.

FIELD CONTROL WIRING

The 50FCQ unit requires an external temperature control device. This device can be a thermostat (field-supplied) or a SystemVu™ controller (available as factory-installed option for use on a Carrier Comfort Network® or as a stand-alone control).

THERMOSTAT

Install a Carrier approved accessory thermostat according to installation instructions included with the accessory. Locate the thermostat accessory on a solid wall in the conditioned space to sense average temperature in accordance with the thermostat installation instructions.

When electric heat is installed in the 50FCQ unit, the thermostat must be capable of energizing the G terminal (to energize the Indoor Fan Contactor) whenever there is a space call for heat (energizing the W1 terminal). The accessory thermostats listed on the unit price pages can provide this signal but they are not configured to enable this signal as shipped.

See Fig. 41 for typical low voltage control connections.

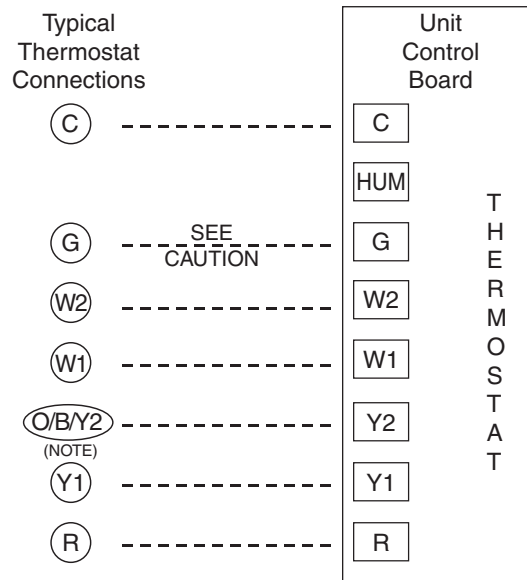

NOTE: Typical multi-function marking. Follow manufacturer's configuration Instructions to select Y2.

--- Field Wiring

Fig. 41 — Typical Low-Voltage Control Connections

⚠ CAUTION

UNIT DAMAGE HAZARD

Failure to follow this caution may cause a short circuit.

Carefully check the connection of control conductor for indoor fan control at terminal G. Connecting the indoor fan lead to terminal C will cause a short circuit condition, which can cause component damage inside the unit or at the thermostat.

If the thermostat contains a logic circuit requiring 24-v power, use a thermostat cable or equivalent single leads of different colors

with minimum of seven leads. If the thermostat does not require a 24-v source (no “C” connection required), use a thermostat cable or equivalent with minimum of six leads. Check the thermostat installation instructions for additional features which might require additional conductors in the cable.

For wire runs up to 50 ft (15 m), use no. 18 AWG (American Wire Gage) insulated wire (35°C minimum). For 50 to 75 ft (15 to 23 m), use no. 16 AWG insulated wire (35°C minimum). For over 75 ft (23 m), use no. 14 AWG insulated wire (35°C minimum). All wire sizes larger than no. 18 AWG cannot be directly connected to the thermostat and will require a junction box and splice at the thermostat.

Unit Without Thru-Base Connection Kit

Correctly rated low voltage wire can be routed through the rubber grommet located on the corner post adjacent to the control box access panel. Route wire through the grommet and then route the wire behind the corner post utilizing the factory provided wire ties secured to the control box. This will ensure separation of the field low voltage wire and the high voltage circuit. Route the low voltage wire to the central terminal board. See Fig. 42.

NOTE: If utilizing the through the base connections, route the low voltage wire through the wire ties to the central terminal board.

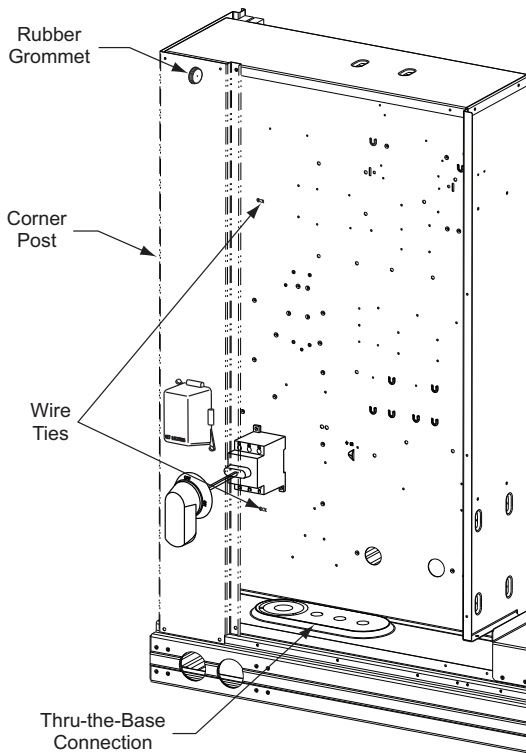

Fig. 42 — Field Control Wiring Raceway

Configure for Electric Heat

To configure the factory-approved thermostat, open the Advanced Setup menu, scroll down to ELECTRIC HEAT and change RANGE value from OFF to ON. Consult the thermostat installation instructions for full details.

Heat Anticipator Settings

Set heat anticipator settings at 0.14 amp for the first stage and 0.14 amp for second-stage heating.

Transformer Connection for 208-v Power Supply

All units except 208/230-v units are factory wired for the voltage shown on the nameplate. If the 208/230-v unit is to be connected to a 208-v power supply, the control transformer must be rewired by moving the black wire with the 1/4 in. female spade connector from the 230-v connection and moving it to the 208-v 1/4 in. male terminal on the primary side of the transformer. Refer to unit label diagram for additional information.

COMMERCIAL DEFROST CONTROL

On 50FCQ units equipped with electro-mechanical controls the Defrost Control Board (DFB) coordinates thermostat demands for supply fan control, 2 stage cooling, 2 stage heating, emergency heating and defrost control with unit operating sequences. The DFB also provides an indoor fan off delay feature (user selectable). See Fig. 43 for board arrangement.

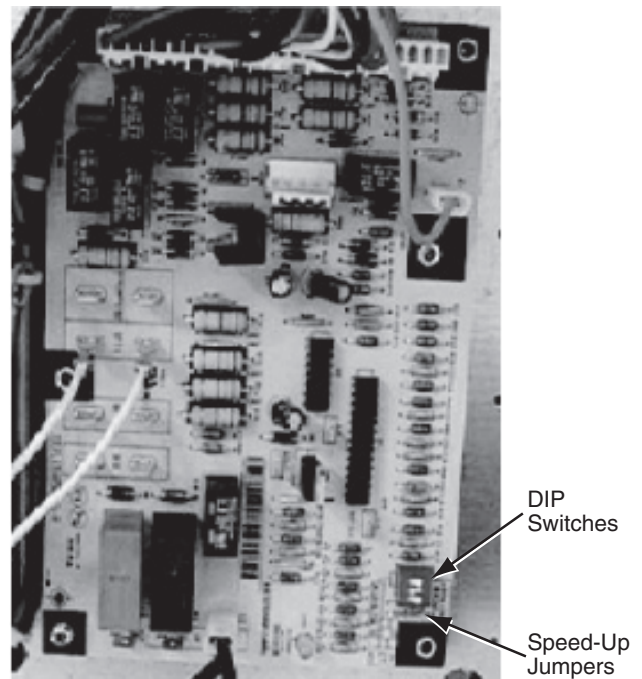

Fig. 43 — Defrost Control Board Arrangement

The DFB is located on the right side wall of the control box of the 50FCQ unit (see Fig. 44). All connections are factory-made through harnesses to the UCB (unit control board) to the ECM (direct-drive motor), reversing valve solenoids and to defrost thermostats. Refer to Table 3 for details of DFB Inputs and Outputs.

NOTE: The Defrost Control Board is not used on units equipped with the factory-installed SystemVu™ controller option.

Reversing valve control

The DFB has two outputs for unit reversing valve control. Operation of the reversing valves is based on internal logic; this application does not use an “O” or “B” signal to determine reversing valve position. Reversing valves are energized during the cooling stages and the defrost cycle and de-energized during heating cycles. Once energized at the start of a cooling stage, the reversing valve will remain energized until the next heating cycle demand is received. Once de-energized at the start of a Heating cycle, the reversing valves will remain de-energized until the next cooling stage is initiated.

Compressor control

The DFB receives inputs indicating Stage 1 Cooling, Stage 2 Cooling and Stage 1 Heating from the space thermostat or unit control system (SystemVu™ controller); it generates commands to start compressors with or without reversing valve operation to produce Stage 1 Cooling (one compressor runs), Stage 2 Cooling (both compressors run) or Stage 1 Heating (both compressors run).

Auxiliary (Electric) Heat control

The 50FCQ unit can be equipped with an auxiliary electric heater, to provide a second stage of heating. The DFB will energize this Heating System for a Stage 2 Heating Command (heaters operate concurrently with compressor(s) in the Stage 1 Heating cycle), for an Emergency Heating sequence (compressors are off and only the electric heaters are energized) and also during the Defrost cycle (to eliminate a “cold blow” condition in the space).

Table 3 — 50FCQ Defrost Board I/O and Jumper Configurations

POINT NAME	TYPE OF I/O	CONNECTION PIN NUMBER	UNIT CONNECTION	NOTE
INPUTS				
G Fan	DI, 24 vac	P2-3	UCB-REHEAT/HP-6	
Y1 Cool 1	DI, 24 vac	P2-5	UCB-REHEAT/HP-1	
Y2 Cool 2	DI, 24 vac	P2-4	UCB-REHEAT/HP-3	
W1 Heat 1	DI, 24 vac	P2-7	UCB-MAIN-3	
W2 Heat 2	DI, 24 vac	P2-6	UCB-MAIN-2	
R Power	24 vac	P3-1	UCB-MAIN-6	
C Common	24 vac	P3-2	UCB-MAIN-9	
DFT 1	DI, 24 vac	DFT-1 to DFT-1	—	DFT1 input not used
DFT 2	DI, 24 vac	DFT-2 to DFT-2	—	
OUTPUTS				
I/O Fan On	DO, 24 vac	P3-9	USB-REHEAT/HP-4	
OF OD Fan On	DO, 24 vac	OF	OFC and TBR-4	
RVS1	DO, 24 vac	P3-7 to P3-5	RVSR	Energize in COOL
RVS2	DO, 24 vac	P3-6 to P3-4	RVSR	Energize in COOL
COMP 1	DO, 24 vac	P3-10	UCB-REHEAT/HP-2	
COMP2	DO, 24 vac	P3-8	UCB-REHEAT/HP-4	
HEAT 2	DO, 24 vac	E-HEAT	EHR	
CONFIGURATION				
Select Jumper	24 vac	P1-1 to P1-3	—	
SPEED-UP CONFIGURATION				
Speed-Up Jumper	—	JMP17	—	
Speed-Up Jumper	—	JMP18	—	

NOTES:

1. Jumper for 1-3 seconds: Factory Test — The defrost interval timing is reduced by a factor of 0.1 seconds/minute based on the positions of DIP switches SW1 and SW2 (i.e., 90 minutes will be reduced to 9 seconds).
2. Jumper for 5-20 seconds: Forced Defrost — Defrost runs for 30 seconds if DFT2 is open.

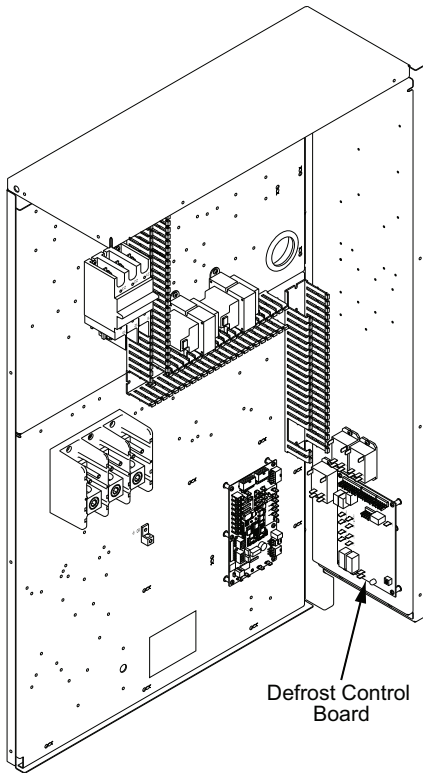

Fig. 44 — Defrost Control Board Location

Defrost

The defrost control mode is a time/temperature sequence. There are two time components: The continuous run period and the test/defrost cycle period. The temperature component is provided by Defrost Thermostat 1 and 2 (DFT1 and DFT2) mounted on the outdoor coil. These are wired in series into the DFT2 input on the DFB controller or wired in series as input to SystemVu™ controller.

The continuous run period is a fixed time period between the end of the last defrost cycle (or start of the current Heating cycle) during which no defrost will be permitted. This period can be set at 30, 60, 90 or 120 minutes by changing the positions of DIP switches SW1 and SW2 (see Fig. 45 and Table 4). The default run period is 30 minutes.

Shorting the jumpers for a period of 5 to 20 seconds bypasses the remaining continuous run period and places the unit in a Forced Defrost mode. If the controlling DFT is closed when this mode is initiated, the unit will complete a normal defrost period that will terminate when the controlling DFT opens or the 10 minute defrost cycle limit is reached. If the controlling DFT is open when this mode is initiated, the Defrost cycle will run for 30 seconds. Both modes end at the end of the Defrost cycle.

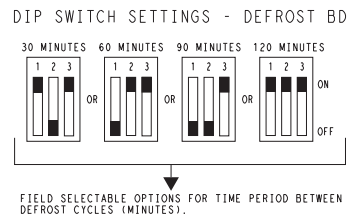

Fig. 45 — DIP Switch Settings — Defrost Board

Table 4 — DIP Switch Positions

	1	2	1	2	1	2	1	2	1	2	3		
1	•		1		1		1		•		•	1	On
0		•	0	•	0	•	•	0				0	Off
	30 minutes (factory default)		60 minutes		90 minutes		120 minutes					Fan Delay	

ELECTRIC HEATERS

The 50FCQ units may be equipped with field-installed accessory electric heaters. The heaters are modular in design.

Heater modules are installed in the compartment below the indoor blower access panel. Access is through the electric heat access panel. Heater modules slide into the compartment on tracks along the bottom of the heater opening. See Fig. 46-48. Refer to the Electric Heater Kit Installation Instructions for complete details.

Not all available heater modules may be used in every unit. Use only those heater modules that are approved for use in a specific size unit. Refer to the label on the unit cabinet for the list of approved heaters.

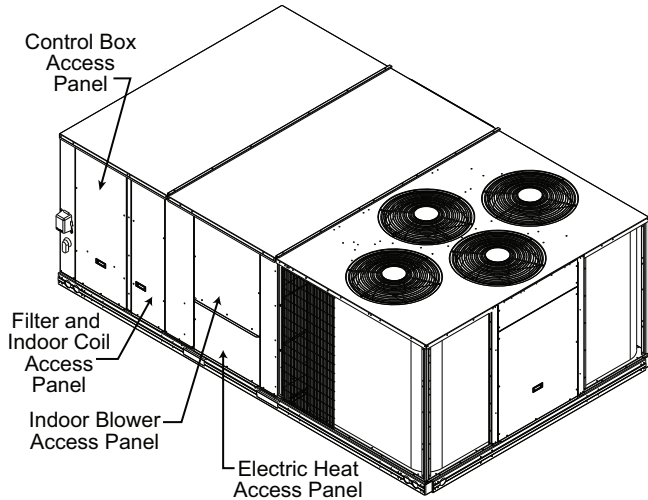

Fig. 46 — Typical Access Panel Locations

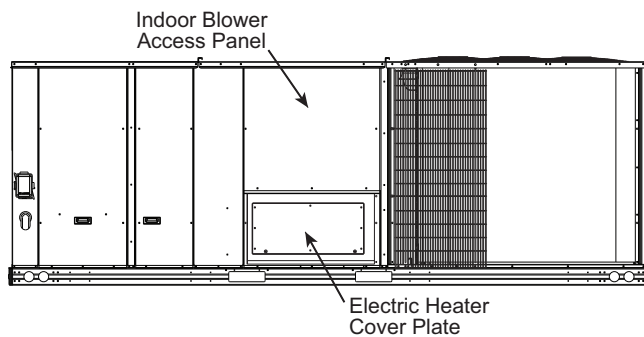

Fig. 47 — Electric Heater Compartment with Cover Plate

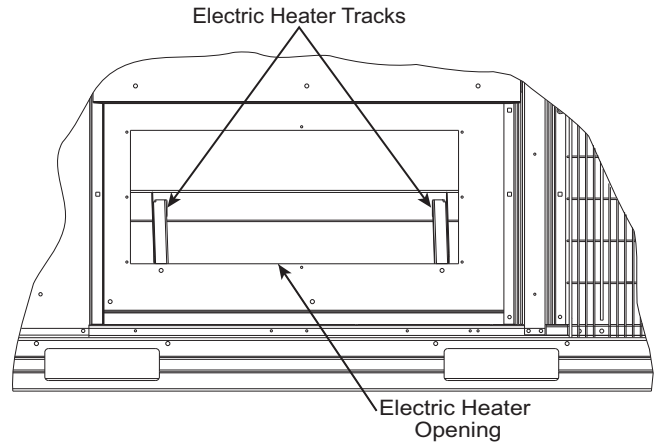

Fig. 48 — Electric Heater Compartment (Cover Plate Removed)

Low-Voltage Control Connections

Locate the plug assembly in the electric heater section of the main unit. Connect the plug with the mating low voltage plug located on the heater. See Fig. 49.

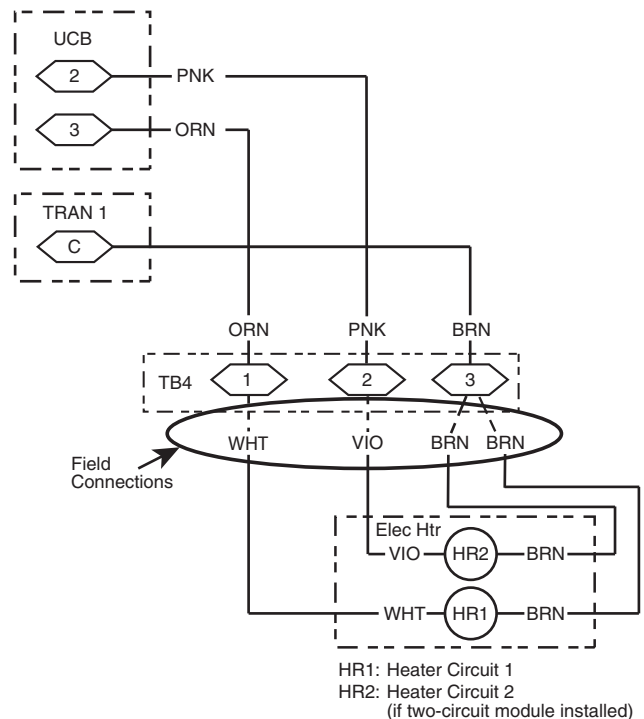

Fig. 49 — Accessory Electric Heater Control Connections

Typical Unit Wiring Diagrams

See Fig. 50-61 for examples of typical unit control and power wiring diagrams. These wiring diagrams are mounted on the inside of the unit control box. Refer to the wiring diagrams in the unit control box when making field power wiring connections.

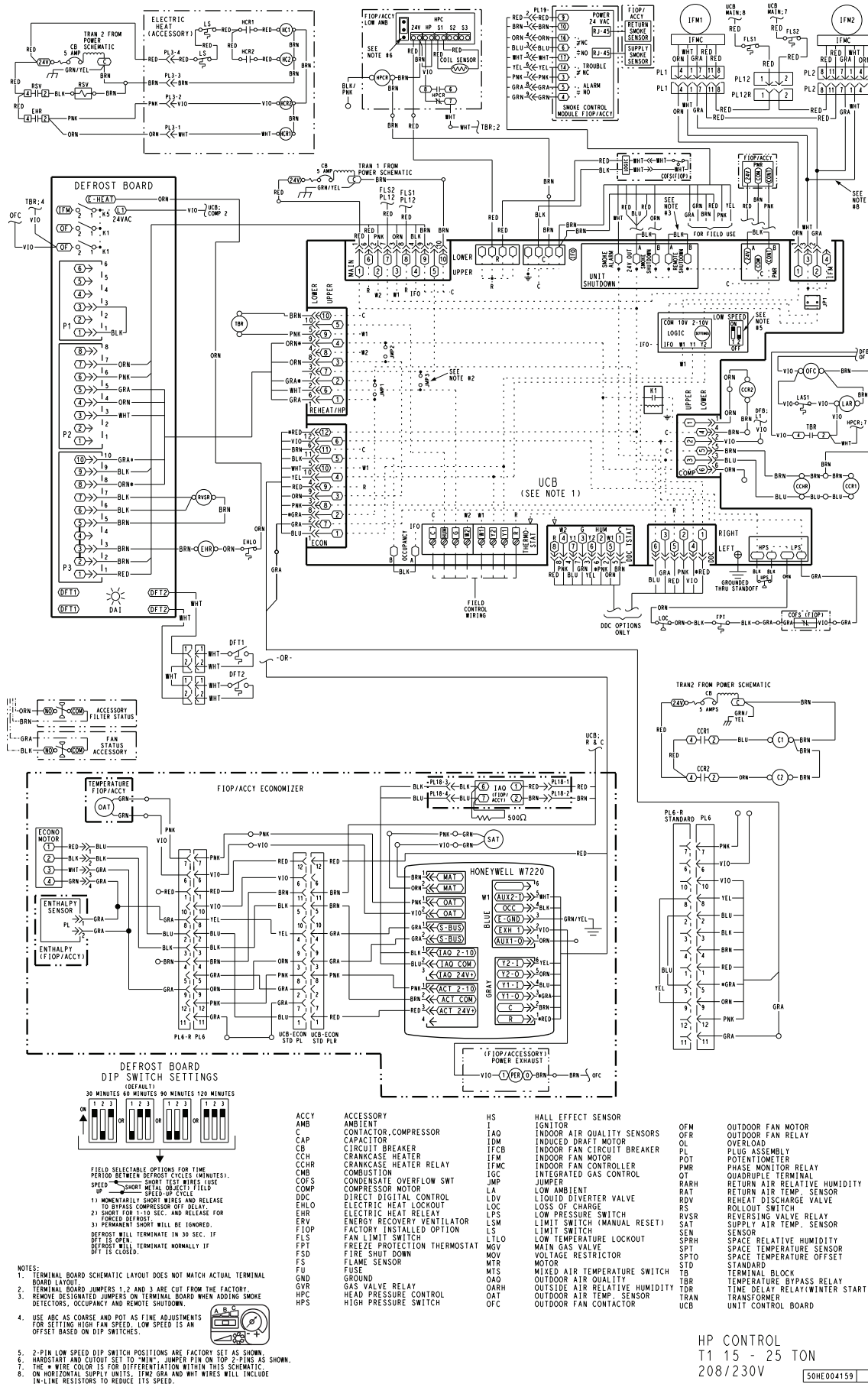

Fig. 50 — Typical 50FCQ*17-28 Control Wiring Diagram, Electro-Mechanical with W7220 Controller, 208/230V-3-60 Unit Shown

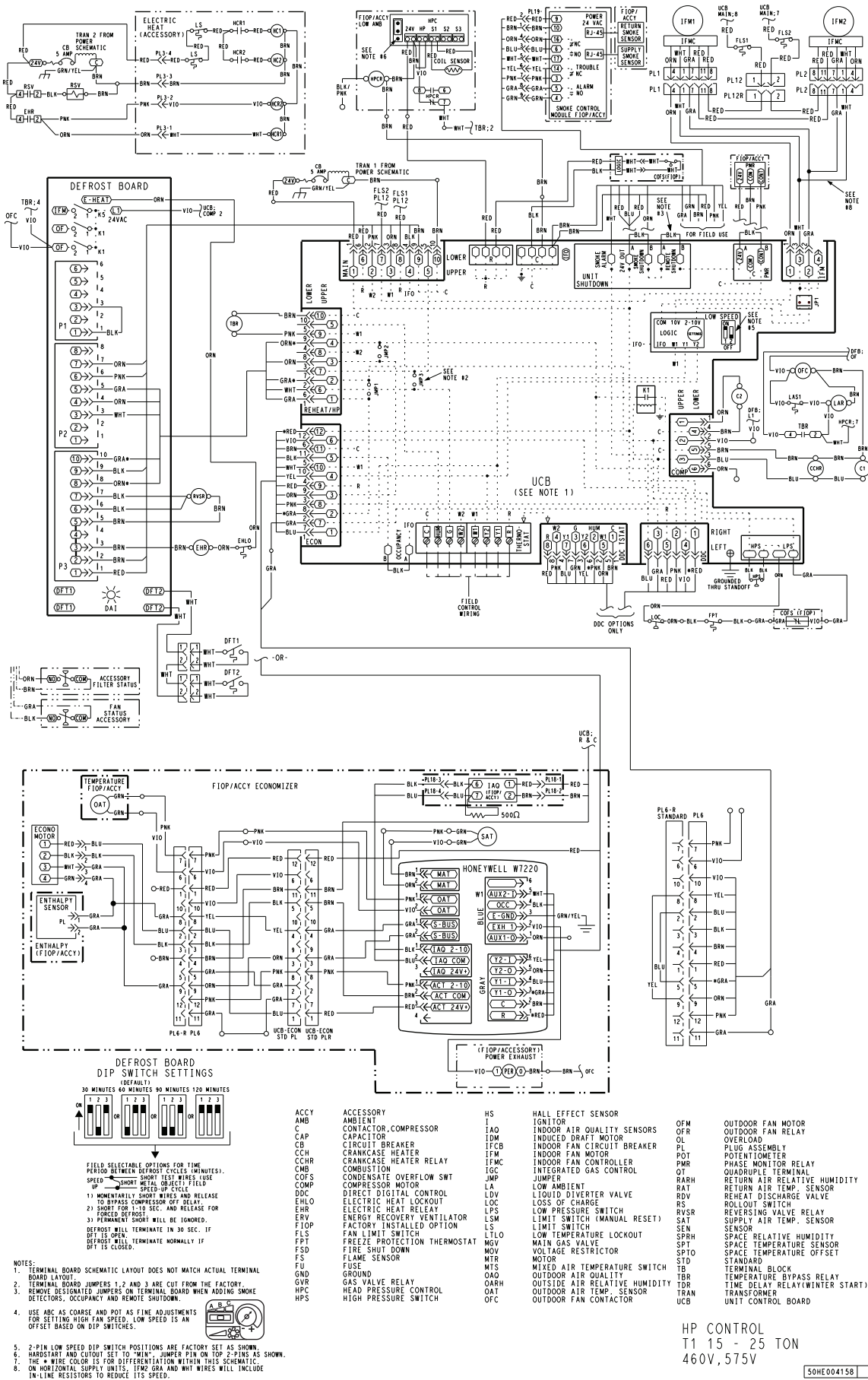

Fig. 51 — Typical 50FCQ*17-28 Control Wiring Diagram, Electro-Mechanical with W7220 Controller, 460V, 575V-3-60 Unit Shown

HP CONTROL
 T1 15 - 25 TON
 460V, 575V

50HE004158

HP POWER T1 15 TON
208/230V

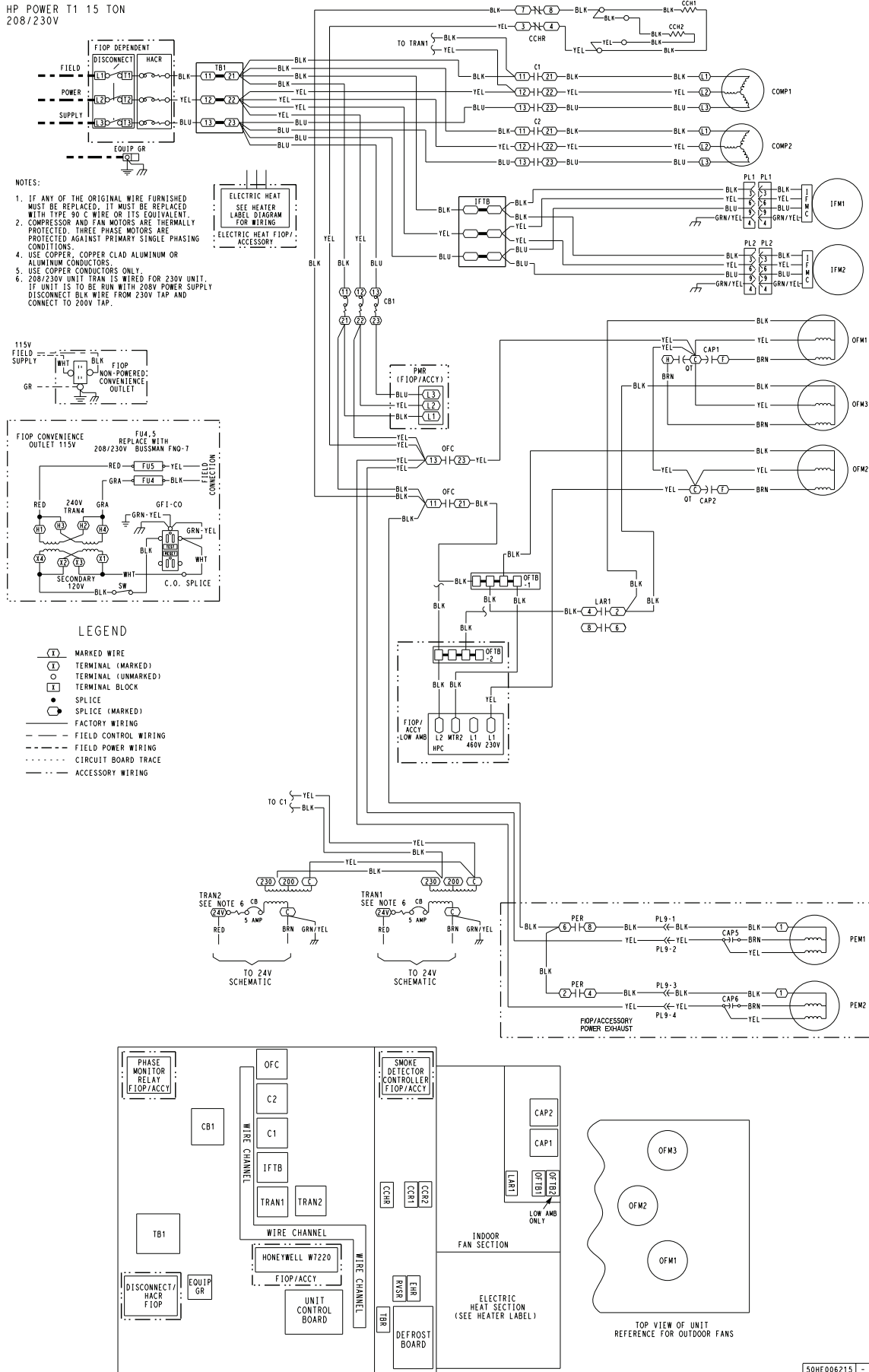

Fig. 52 — Typical 50FCQ*17 Power Wiring Diagram, Electro-Mechanical Controller, 15 Ton 208/230V-3-60 Unit Shown

PAC POWER T1 17.5, 20, 25 TON
 HP POWER T1 20 & 25 TON
 208/230V

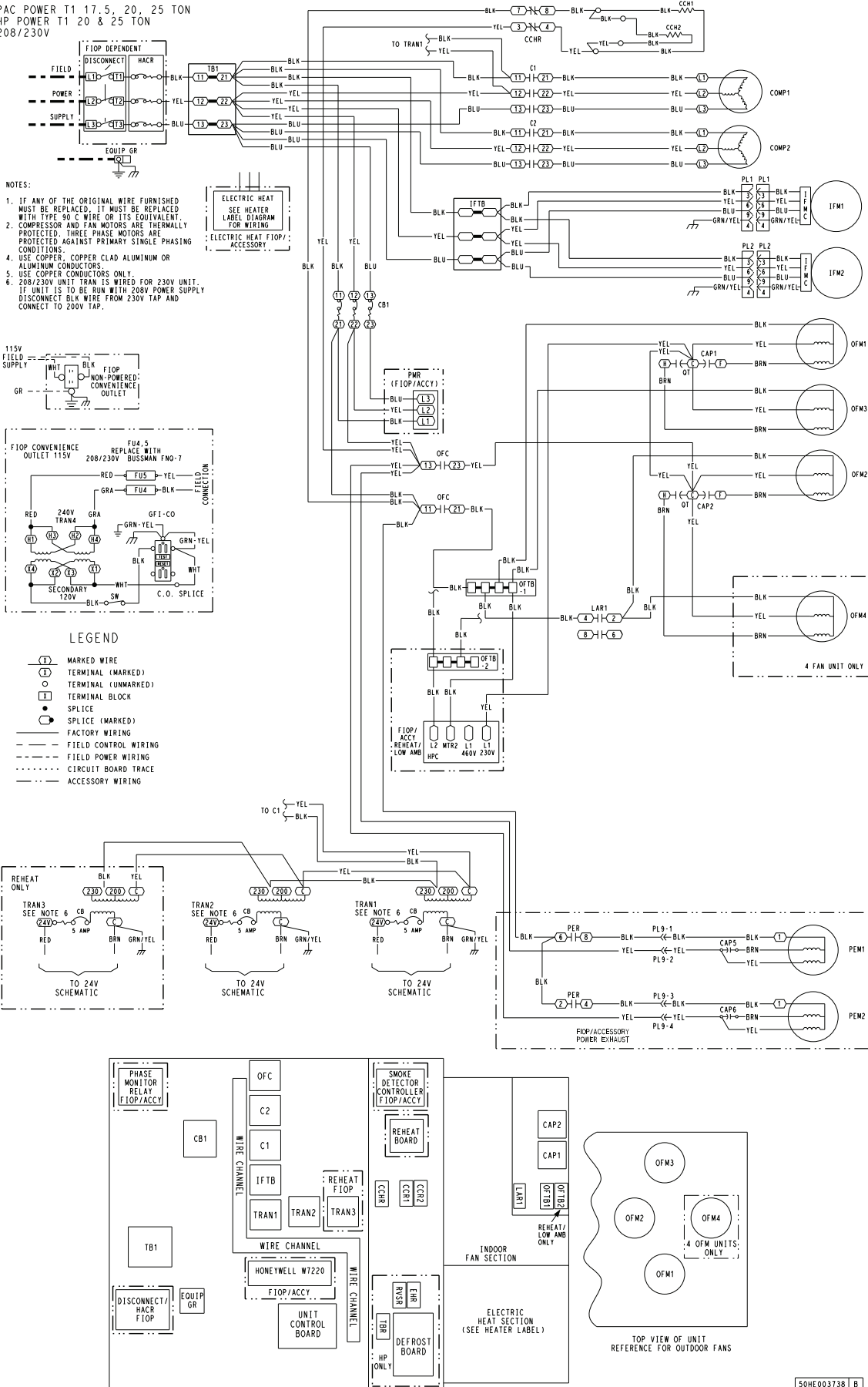

Fig. 53 — Typical 50FCQ*24-28 Power Wiring Diagram, Electro-Mechanical Controller, 20-25 Ton 208/230V-3-60 Unit Shown

HP POWER T1 15 TON
460V

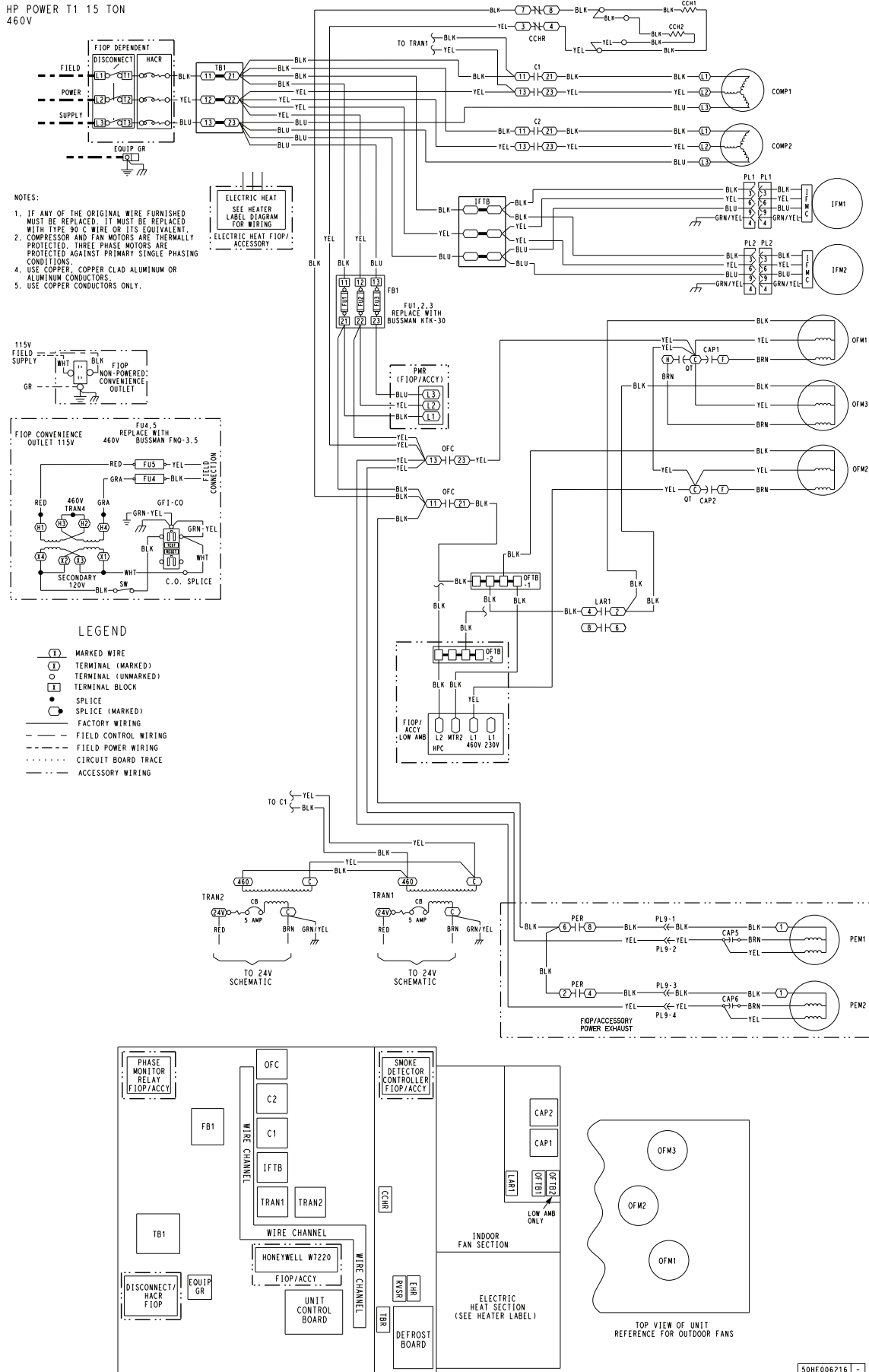

Fig. 54 — Typical 50FCQ*17 Power Wiring Diagram, Electro-Mechanical Controller, 15 Ton 460V-3-60 Unit Shown

PAC POWER T1 17.5, 20, 25 TON
 HP POWER T1 20 & 25 TON
 460V

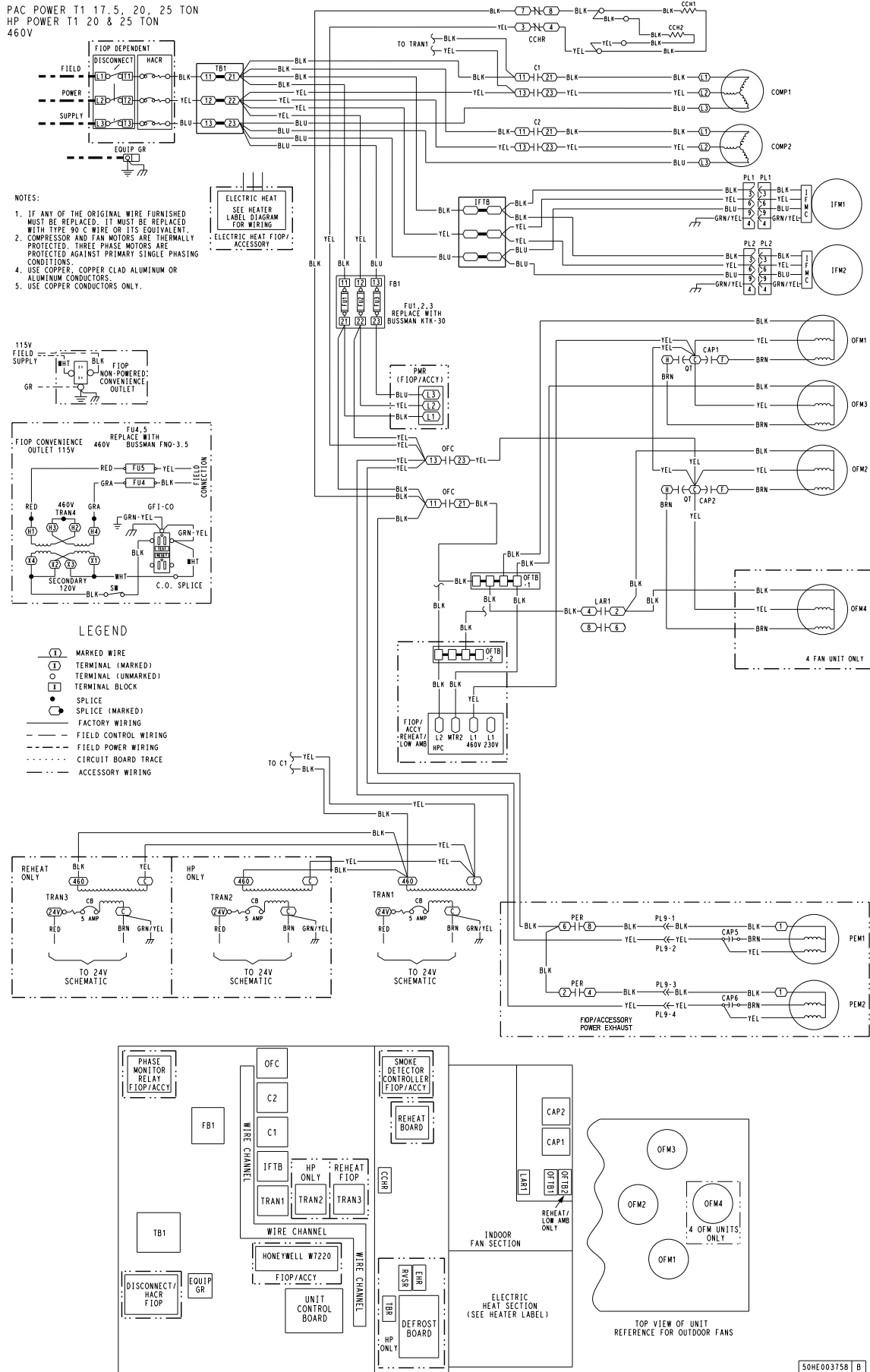

Fig. 55 — Typical 50FCQ*24-28 Power Wiring Diagram, Electro-Mechanical Controller, 460V-3-60 Unit Shown

HP CONTROL SVU
T1 15 - 25 TON
460V, 575V

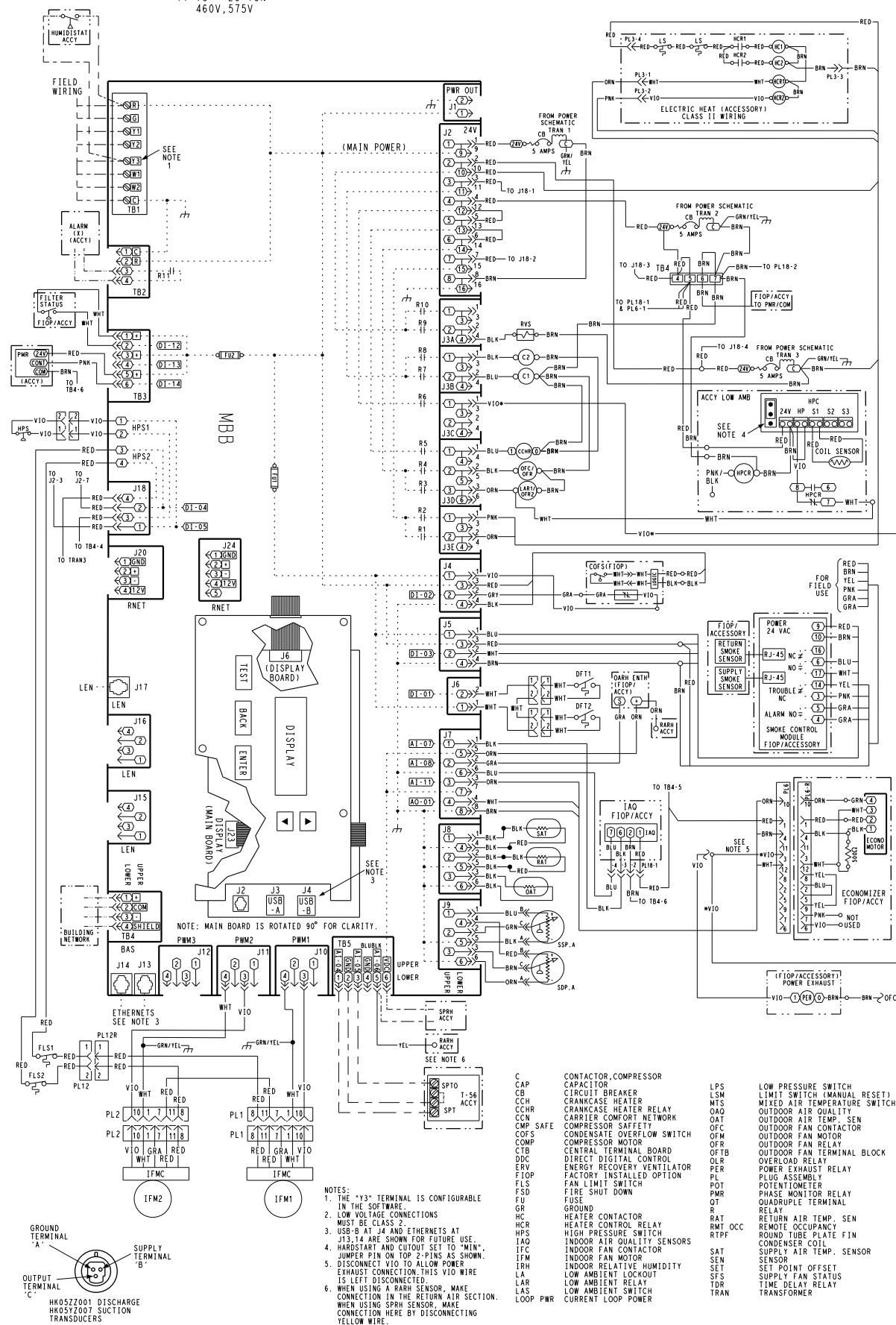

Fig. 57 — Typical 50FCQ*17-28 Control Wiring Diagram, SystemVu™ Controller, 460V, 575V-3-60 Unit Shown

HP POWER T1 15 TON
208/230V SVU

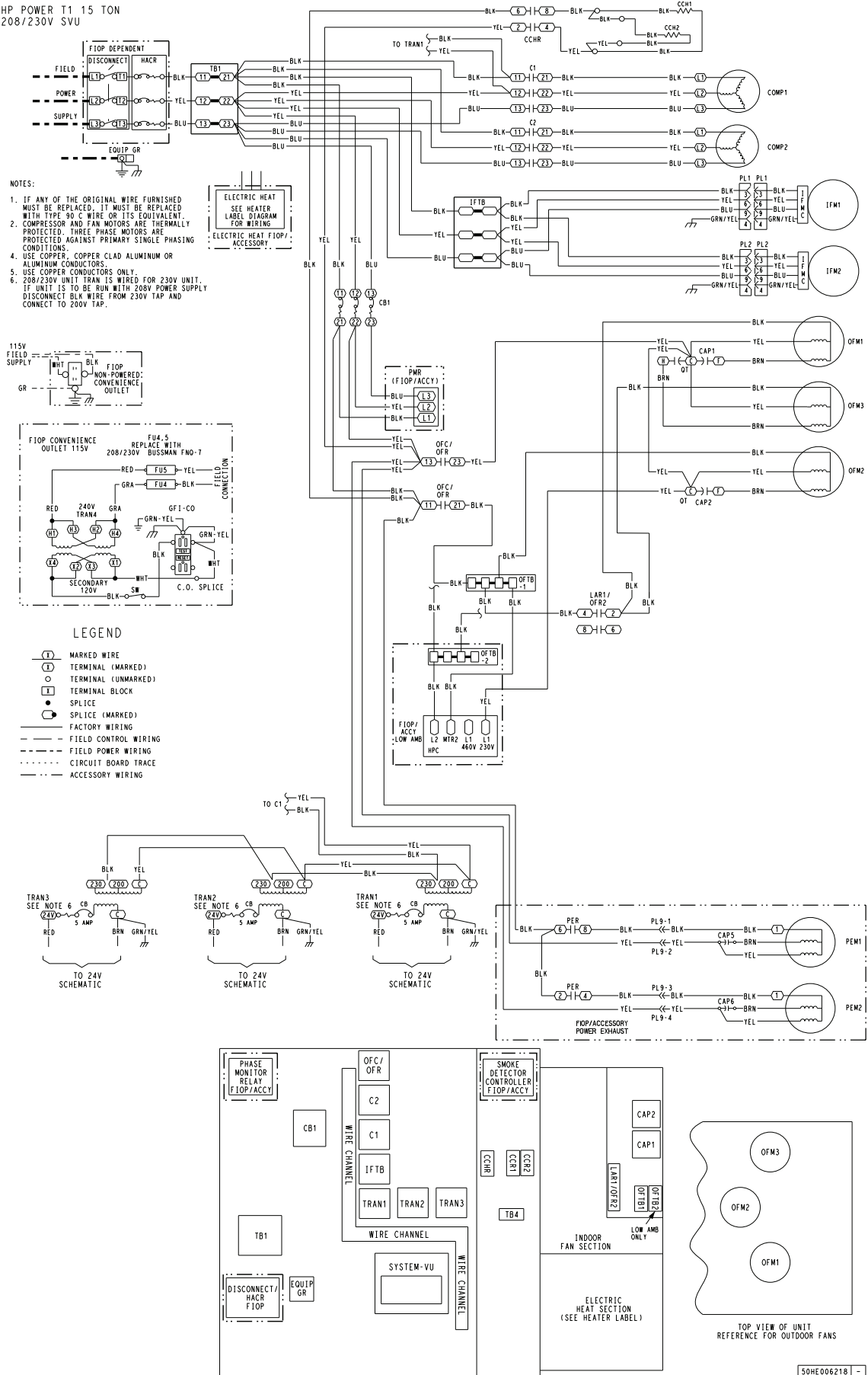

Fig. 58 — Typical 50FCQ*17 Power Wiring Diagram, SystemVu™ Controller, 15 Ton 208/230V-3-60 Unit Shown

PAC POWER T1 17.5, 20, 25 TON
 HP POWER T1 20 & 25 TON
 208/230V SVU

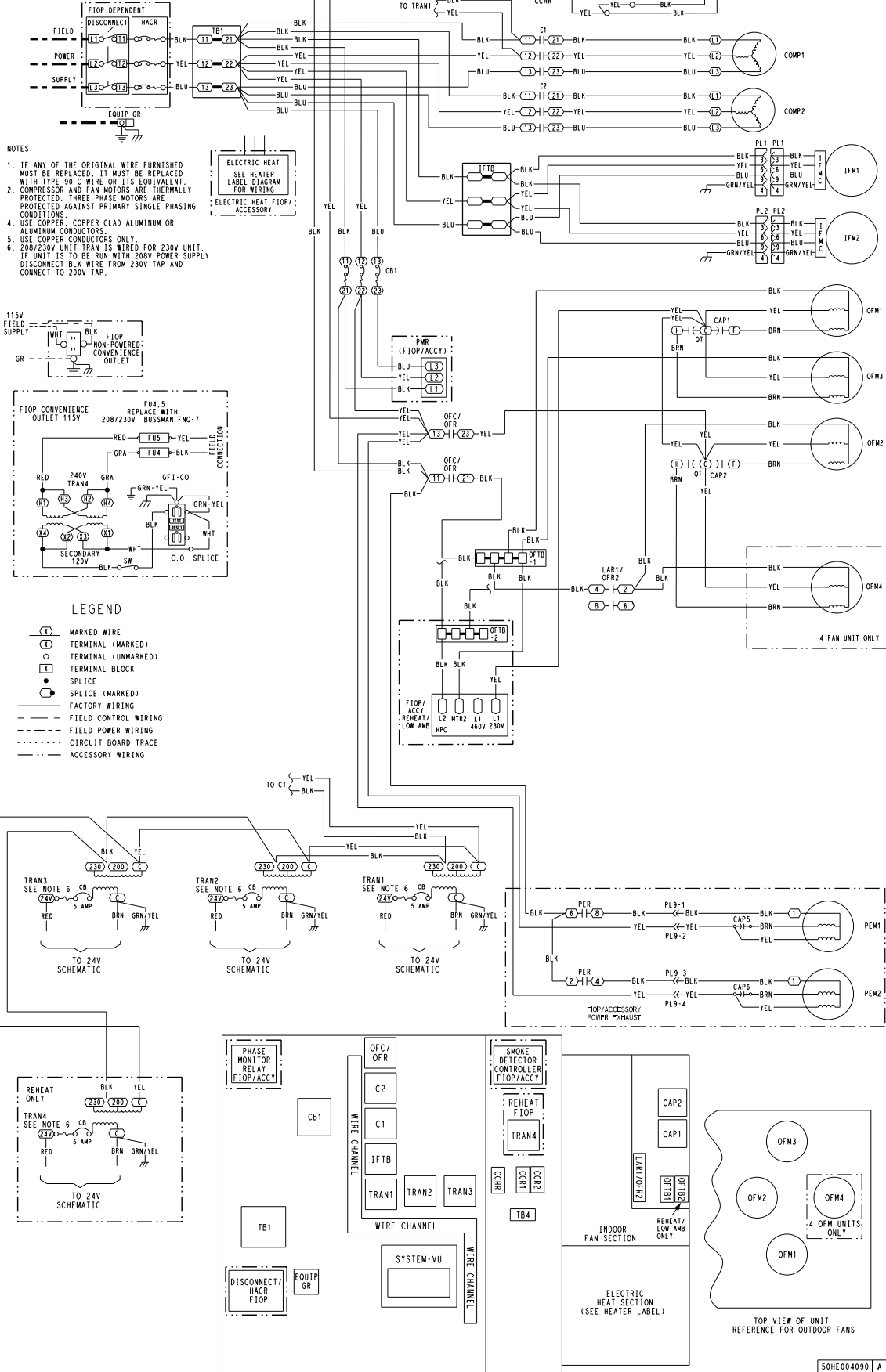

Fig. 59 — Typical 50FCQ*24-28 Power Wiring Diagram, SystemVu™ Controller, 20-25 Ton 208/230V-3-60 Unit

HP POWER T1 15 TON
460V SVU

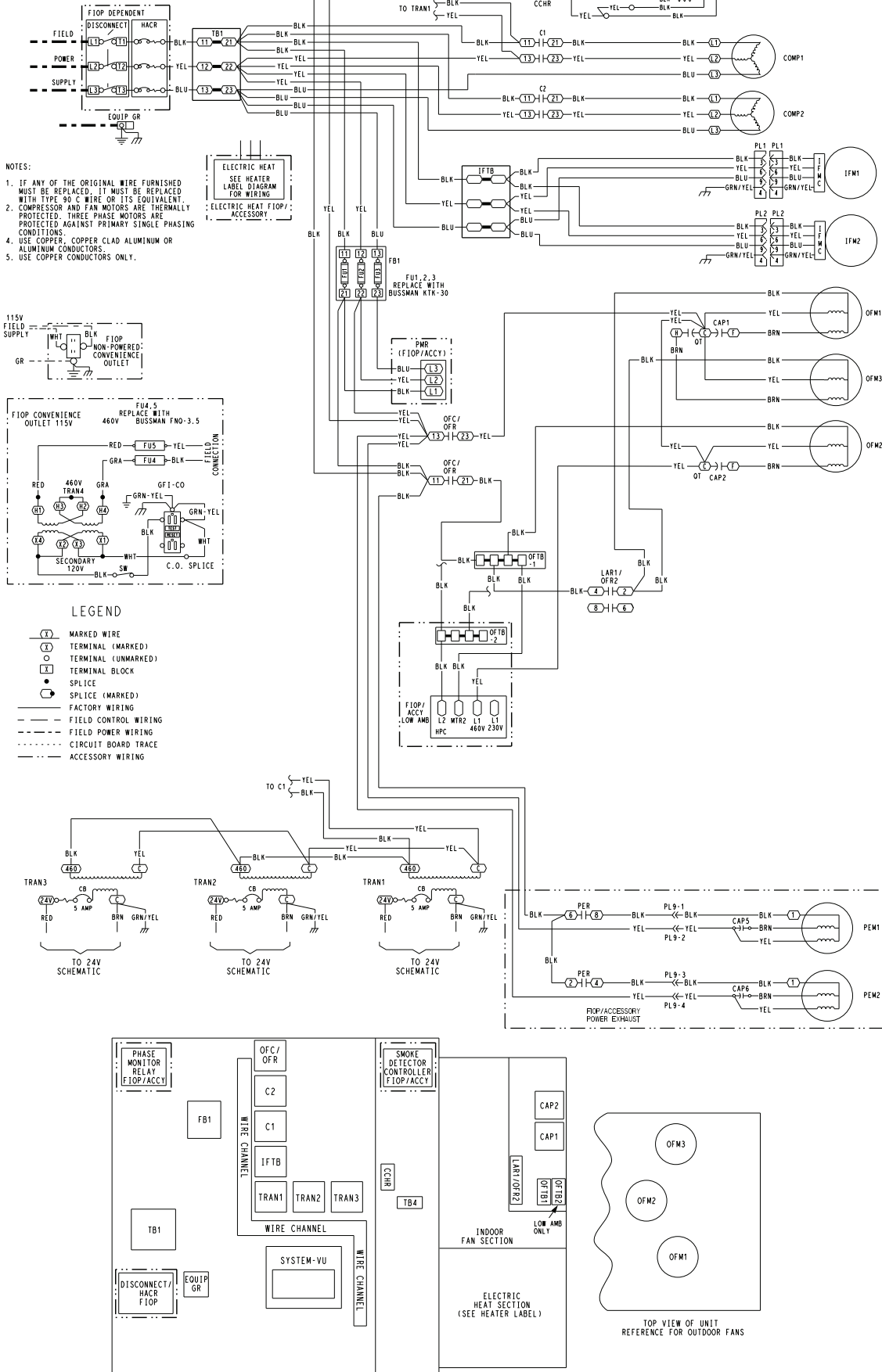

Fig. 60 — Typical 50FCQ*17 Power Wiring Diagram, SystemVu™ Controller, 15 Ton 460V-3-60 Unit Show

PAC POWER T1 17.5, 20, 25 TON
 HP POWER T1 20 & 25 TON
 460V SVU

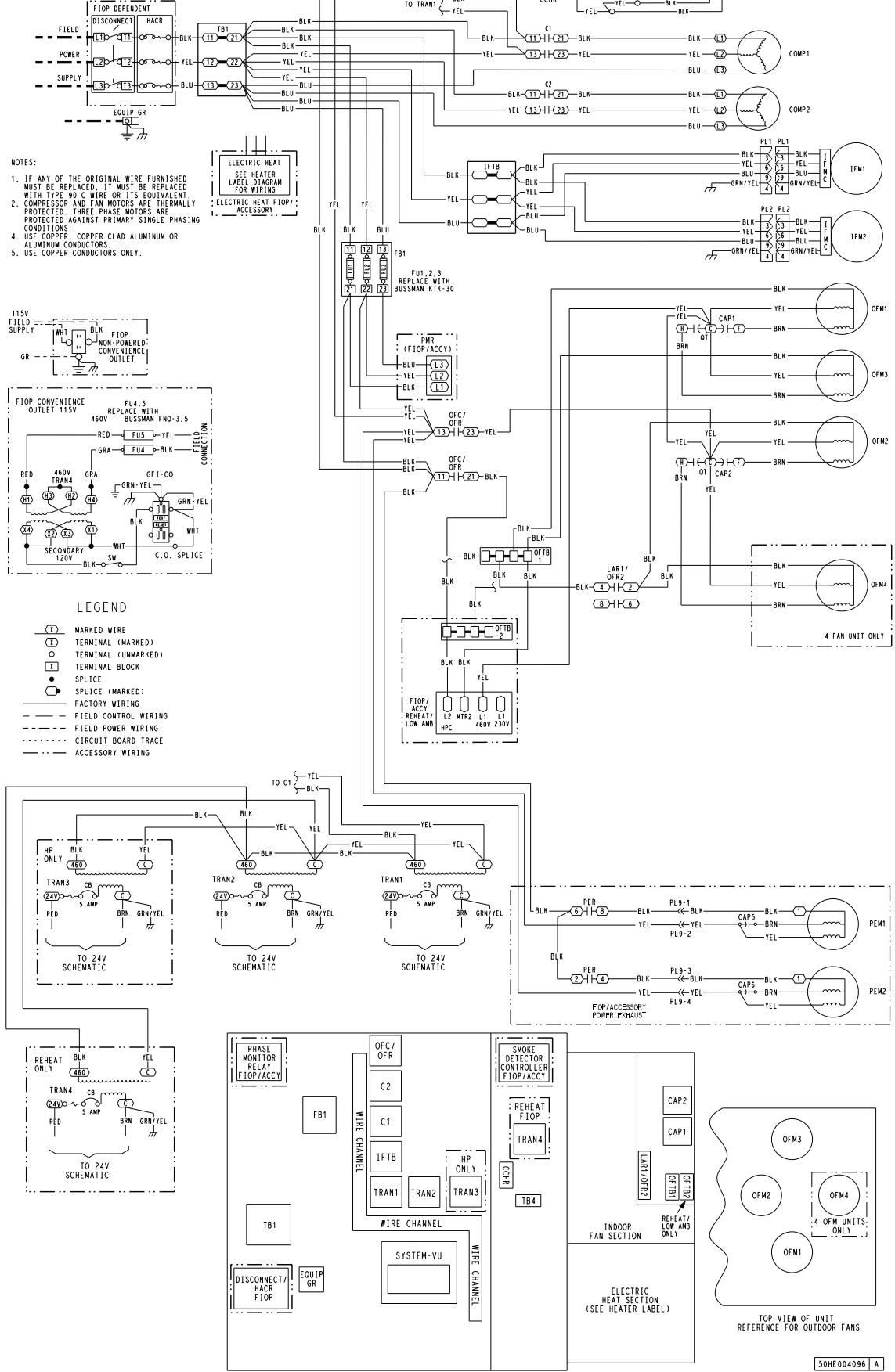

Fig. 61 — Typical 50FCQ*24-28 Power Wiring Diagram, SystemVu™ Controller, 15 Ton 460V-3-60 Unit Shown

EconoMi\$er X (Factory-Installed Option)

PRODUCT DESCRIPTION

The EconoMi\$er® X system is an expandable economizer control system, which includes a W7220 economizer module (controller) with an LCD and keypad (see Fig. 62). The W7220 module can be configured with optional sensors.



Fig. 62 — W7220 Economizer Module

The W7220 economizer module can be used as a stand-alone economizer module wired directly to a commercial set-back space thermostat and sensors to provide outside air dry-bulb economizer control.

The W7220 economizer module can be connected to optional sensors for single or differential enthalpy control. The W7220 economizer module provides power and communications for the sensors.

The W7220 economizer module automatically detects sensors by polling to determine which sensors are present. If a sensor loses communications after it has been detected, the W7220 economizer controller indicates a device fail error on its LCD.

SYSTEM COMPONENTS

The EconoMi\$er X system includes an economizer module, 20k mixed air sensor, damper actuator, and either a 20k outdoor air temperature sensor or S-Bus enthalpy sensors.

Economizer Module

The module is the core of the EconoMi\$er X system. The module is mounted in the unit's control box, and includes the user interface for the system. The W7220 economizer module provides the basic inputs and outputs to provide simple economizer control. When used with the optional sensors, the economizer module provides more advanced economizer functionality.

S-Bus Enthalpy Control Sensors

The sensor is a combination temperature and humidity sensor which is powered by and communicates on the S-Bus. Up to three sensors may be configured with the W7220 economizer module.

CO₂ Sensor (optional)

The sensor can be added for Demand Controlled Ventilation (DCV).

SPECIFICATIONS

W7220 Economizer Module

The module is designed for use with 2 to 10 vdc or bus communicating actuator. The module includes terminals for CO₂ sensor, Mixed Air sensor, and an Outdoor Dry Bulb sensor. Enthalpy and other options are available with bus sensors.

User Interface

Provides status for normal operation, setup parameters, checkout tests, and alarm and error conditions with a 2-line 16 character LCD display and four button keypad.

Electrical

Rated Voltage — 20 to 30 vac RMS, 50/60 Hz

Transformer — 100 va maximum system input

Nominal Power Consumption (at 24 vac, 60 Hz) — 11.5 VA without sensors or actuators

Relay Digital Output Rating at 30 vac (maximum power from Class 2 input only) — 1.5A run:

3.5A inrush at 0.45PF (200,000 cycles) or

7.5A inrush at 0.45PF (100,000 cycles)

External Sensors Power Output — 21 vdc ± 5% at 48mA

IMPORTANT: All inputs and outputs must be Class 2 wiring.

INPUTS

Sensors

NOTE: A Mixed Air (MA) analog sensor is required on all W7220 units; either an Outdoor Air (OA) sensor for dry bulb change over or an OA bus sensor for outdoor enthalpy change over is required in addition to the MA sensor. An additional Return Air (RA) bus sensor can be added to the system for differential enthalpy or dry bulb changeover. For differential dry bulb changeover, a 20k ohm sensor is required in the OA and a bus sensor in the RA. DIP switch on RA bus sensor must be set in the RA position.

Dry Bulb Temperature (optional) and Mixed Air (required), 20k NTC

2-wire (18 to 22 AWG);

Temperature range -40°F to 150°F (-40°C to 65°C)

Temperature accuracy -0°F/+2°F

Temperature and Humidity, C7400S1000 (optional)

S-Bus; 2-wire (18 to 22 AWG)

Temperature: range -40°F to 150°F (-40°C to 65°C)

Temperature accuracy -0°F/+2°F

Humidity: range 0 to 100% RH with 5% accuracy.

NOTE: Up to three (3) S-Bus sensors may be connected to the W7220 economizer module. For outdoor air (OA), return air (RA) and discharge (supply) air (DA).

4 Binary Inputs

1-wire 24 vac + common GND (see page 43 for wiring details).

24 vac power supply

20 to 30 vac 50/60Hz; 100 VA Class 2 transformer.

OUTPUTS

Actuator Signal:

2-10 vdc; minimum actuator impedance is 2k ohm; bus two-wire output for bus communicating actuators.

Exhaust fan, Y1, Y2 and AUX1 O:

All Relay Outputs (at 30 vac):

Running: 1.5A maximum

Inrush: 7.5A maximum

ENVIRONMENTAL

Operating Temperature:

-40°F to 150°F (-40°C to 65°C)

Exception of display operation down to -4°F (-20°C) with full recovery at -4°F (-20°C) from exposure to -40°F (-40°C)

Storage Temperature:

-40°F to 150°F (-40°C to 65°C)

Shipping Temperature:

-40°F to 150°F (-40°C to 65°C)

Relative Humidity:

5% to 95% RH non-condensing

ECONOMIZER MODULE WIRING DETAILS

Use Fig. 63 and Tables 5 and 6 to locate the wiring terminals for the Economizer module.

NOTE: The four terminal blocks are removable. You can slide out each terminal block, wire it, and then slide it back into place.

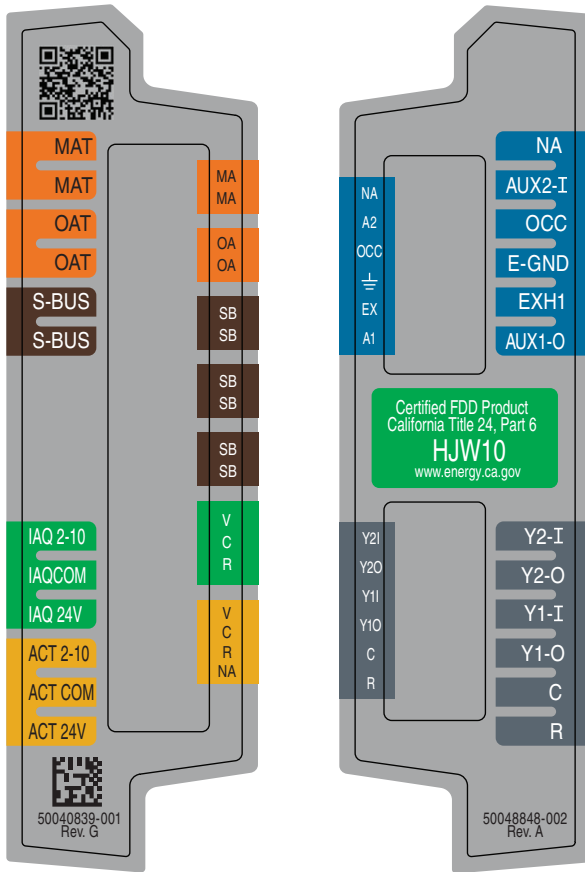

Fig. 63 — W7220 Wiring Terminals

Table 5 — Economizer Module - Left Hand Terminal Blocks

LABEL	TYPE	DESCRIPTION
Top Left Terminal Block		
MAT	20k NTC and COM	Mixed Air Temperature Sensor (Polarity Insensitive Connection)
OAT	20k NTC and COM	Outdoor Air Temperature Sensor (Polarity Insensitive Connection)
S-BUS	S-BUS (Sylk [®] Bus)	Enthalpy Control Sensor (Polarity Insensitive Connection)
Bottom Left Terminal Block		
IAQ 2-10	2-10 vdc	Air Quality Sensor Input (e.g. CO ₂ sensor)
IAQ COM	COM	Air Quality Sensor Common
IAQ 24V	24 vac	Air Quality Sensor 24 vac Source
ACT 2-10	2-10 vdc	Damper Actuator Output (2-10 vdc)
ACT COM	COM	Damper Actuator Output Common
ACT 24-v	24 vac	Damper Actuator 24 vac Source

NOTE(S):

a. Sylk is a trademark of Honeywell International Inc.

Table 6 — Economizer Module - Right Hand Terminal Blocks

LABEL	TYPE	DESCRIPTION
Top Right Terminal Blocks		
AUX2 I	24 vac IN	The first terminal is not used.
OCC	24 vac IN	Shut Down (SD) or HEAT (W) Conventional only and Heat Pump Changeover (O-B) in Heat Pump mode.
E-GND	E-GND	Occupied/Unoccupied Input
EXH1	24 vac OUT	Exhaust Fan 1 Output
AUX1 O	24 vac OUT	Programmable: Exhaust fan 2 output or ERV or System alarm output
Bottom Right Terminal Blocks		
Y2-I	24 vac IN	Y2 in - Cooling Stage 2 Input from space thermostat
Y2-O	24 vac OUT	Y2 out - Cooling Stage 2 Output to stage 2 mechanical cooling
Y1-I	24 vac IN	Y1 in - Cooling Stage 2 Input from space thermostat
Y1-O	24 vac OUT	Y1 out - Cooling Stage 2 Output to stage 2 mechanical cooling
C	COM	24 vac Common
R	24 vac	24 vac Power (hot)

S-BUS SENSOR WIRING

The labels on the sensors and controller are color coded for ease of installation. Orange labeled sensors can only be wired to orange terminals on the controller. Brown labeled sensors can only be wired to S-bus (brown) terminals. Use Fig. 64 and Table 5 to locate the wiring terminals for each S-Bus sensor.

Use Fig. 64 and Table 7 to locate the wiring terminals for each enthalpy control sensor.

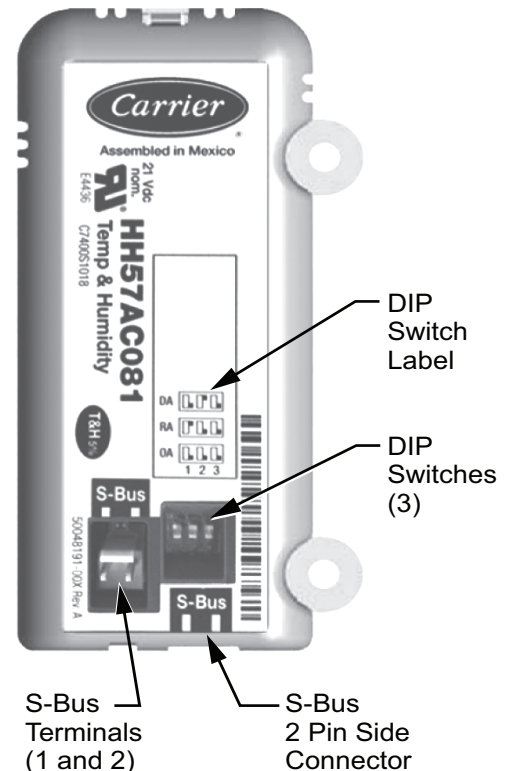

Fig. 64 — S-Bus Sensor DIP Switches

Table 7 — HH57AC081 Sensor Wiring Terminations

TERMINAL		TYPE	DESCRIPTION
NUMBER	LABEL		
1	S-BUS	S-BUS	S-BUS Communications (Enthalpy Control Sensor Bus)
2	S-BUS	S-BUS	S-BUS Communications (Enthalpy Control Sensor Bus)

Use Fig. 64 and Table 8 to set the DIP switches for the desired use of the sensor.

Table 8 — HH57AC081 Sensor DIP Switch

USE	DIP SWITCH POSITIONS FOR SWITCHES 1, 2, AND 3		
	1	2	3
DA	OFF	ON	OFF
RA	ON	OFF	OFF
OA	OFF	OFF	OFF

NOTE: When a S-Bus sensor is connected to an existing network, it will take 60 minutes for the network to recognize and auto-configure itself to use the new sensor.

During the 60 minute setup period, no alarms for sensor failures (except SAT) will be issued and no economizing function will be available.

CO₂ SENSOR WIRING

When using a CO₂ sensor, the black and brown common wires are internally connected and only one is connected to “IAQ COM” on the W7220. Use the power from the W7220 to power the CO₂ sensor OR make sure the ground for the power supplies are common. See Fig. 65 for CO₂ sensor wiring.

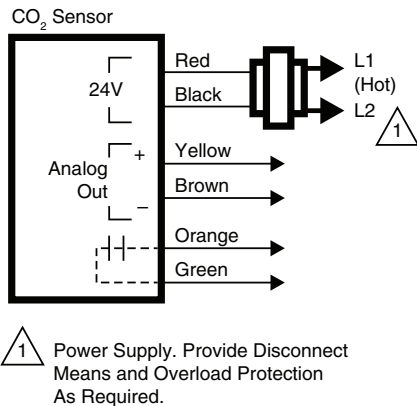

Fig. 65 — CO₂ Sensor Wiring

INTERFACE OVERVIEW

This section describes how to use the EconoMiSer® X user interface for:

- Keypad and menu navigation
- Settings and parameter changes
- Menu structure and selection

USER INTERFACE

The user interface consists of a 2-line LCD display and a 4-button keypad on the front of the economizer controller.

KEYPAD

The four navigation buttons (see Fig. 66) are used to scroll through the menus and menu items, select menu items, and to change parameter and configuration settings.

To use the keypad when working with menus:

- Press the ▲ (Up arrow) button to move to the previous menu.
- Press the ▼ (Down arrow) button to move to the next menu.
- Press the ↵ (Enter) button to display the first item in the currently displayed menu.
- Press the ⏴ (Menu Up/Exit) button to exit a menu’s item and return to the list of menus.

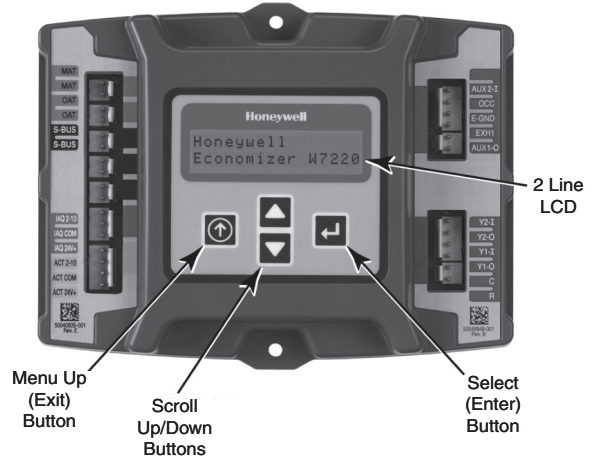

Fig. 66 — W7220 Controller Navigation Buttons

To use the keypad when working with Set Points, System and Advanced Settings, Checkout tests and Alarms:

1. Navigate to the desired menu.
 2. Press the ↵ (Enter) button to display the first item in the currently displayed menu.
 3. Use the ▲ and ▼ buttons to scroll to the desired parameter.
 4. Press the ↵ (Enter) button to display the value of the currently displayed item.
 5. Press the ▲ button to increase (change) the displayed parameter value.
 6. Press the ▼ button to decrease (change) the displayed parameter value.
- NOTE: When values are displayed, pressing and holding the ▲ or ▼ button causes the display to automatically increment.
7. Press the ↵ (Enter) button to accept the displayed value and store it in nonvolatile RAM.
 8. “CHANGE STORED” displays.
 9. Press the ↵ (Enter) button to return to the current menu parameter.
 10. Press the ⏴ (Menu Up/Exit) button to return to the previous menu.

MENU STRUCTURE

Table 9 illustrates the complete hierarchy of menus and parameters for the EconoMiSer X system.

The Menus in display order are:

- STATUS
- SET POINTS
- SYSTEM SETUP
- ADVANCED SETUP
- CHECKOUT
- ALARMS

IMPORTANT: Table 9 illustrates the complete hierarchy. Your menu parameters may be different depending on your configuration.

For example, if you do not have a DCV (CO₂) sensor, then none of the DCV parameters appear and only MIN POS will display. If you have a CO₂ sensor, the DCV MIN and DCV MAX will appear AND if you have 2 speed fan DCV MIN (high and low speed) and DCV MAX (high and low speed will appear).

NOTE: Some parameters in the menus use the letters MA or MAT, indicating a mixed air temperature sensor location before the cooling coil. This unit application has the control sensor located after the cooling coil, in the fan section, where it is designated as (Cooling) Supply Air Temperature or SAT sensor.

SETUP AND CONFIGURATION

Before being placed into service, the W7220 economizer module must be setup and configured for the installed system.

IMPORTANT: During setup, the economizer module is live at all times.

The setup process uses a hierarchical menu structure that is easy to use. Press the ▲ and ▼ arrow buttons to move forward and backward through the menus and press the button to select and confirm setup item changes.

TIME-OUT AND SCREENSAVER

When no buttons have been pressed for 10 minutes, the LCD displays a screen saver, which cycles through the Status items. Each Status items displays in turn and cycles to the next item after 5 seconds.

Table 9 — W7220 Menu Structure^a

MENU	PARAMETER	PARAMETER DEFAULT VALUE	PARAMETER RANGE AND INCREMENT ^b	NOTES
STATUS	ECONO AVAIL	NO	YES/NO	FIRST STAGE COOLING DEMAND (Y1-IN) YES = economizing available; the system can use outside air for free cooling when required
	ECONOMIZING	NO	YES/NO	FIRST STAGE COOLING RELAY OUTPUT YES = outside air being used for 1 stage cooling
	OCCUPIED ^c	NO	YES/NO	OCCUPIED YES = OCC signal received from space thermostat or unitary controller YES = 24 Vac on terminal OCC NO = 0 Vac on terminal OCC
	HEAT PUMP	N/A	COOL HEAT	HEAT PUMP MODE Displays COOL or HEAT when system is set to heat pump (Non-conventional)
	COOL Y1—IN	OFF	ON/OFF	FIRST STAGE COOLING DEMAND (Y1-IN) Y1-I signal from space thermostat or unitary controller for cooling stage 1. ON = 24 Vac on terminal Y1-I OFF = 0 Vac on terminal Y1-I
	COOL Y1—OUT	OFF	ON/OFF	FIRST STAGE COOLING RELAY OUTPUT Cool stage 1 Relay Output to stage 1 mechanical cooling (Y1—OUT terminal)
	COOL Y2—IN	OFF	ON/OFF	SECOND STAGE COOLING DEMAND (Y2-IN) Y2-I signal from space thermostat our unitary controller for second stage cooling. ON = 24 Vac on terminal Y2-I OFF = 0 Vac on terminal Y2-I
	COOL Y2—OUT	OFF	ON/OFF	SECOND STAGE COOLING RELAY OUTPUT Cool Stage 2 Relay Output to mechanical cooling (Y2—OUT terminal).
	MA TEMP ^d	__ . __ F	0°F to 140°F (-17°C to 60°C)	SUPPLY AIR TEMPERATURE, Cooling Mode Displays value of measured mixed air from MAT sensor. Displays __ . __ F if not connected, short or out-of-range.
	DA TEMP	__ . __ F	0°F to 140°F (-17°C to 60°C)	DISCHARGE AIR TEMPERATURE, after Heating section Displays when Discharge Air sensor is connected and displays measured discharge temperature. Displays __ . __ F if sensor sends invalid value, if not connected, short or out-of-range.
	OA TEMP	__ . __ F	-40°F to 140°F (-40°C to 60°C)	OUTSIDE AIR TEMP Displays measured value of outdoor air temperature. Displays __ . __ F if sensor sends invalid value, short or out-of-range.
	OA HUM	__ %	0 to 100%	OUTSIDE AIR RELATIVE HUMIDITY Displays measured value of outdoor humidity from OA sensor. Displays __ % if not connected short, or out-of-range.
	RA TEMP	__ . __ F	0°F to 140°F (-17°C to 60°C)	RETURN AIR TEMPERATURE Displays measured value of return air temperature from RAT sensor. Displays __ . __ F if sensor sends invalid value, if not connected, short or out-of-range
	RA HUM	__ %	0 to 100%	RETURN AIR RELATIVE HUMIDITY Displays measured value of return air humidity from RA sensor. Displays __ % if sensor sends invalid value, if not connected, short or out-of-range.
	IN CO2	__ __ ppm	0 to 2000 ppm	SPACE/RETURN AIR CO ₂ Displays value of measured CO ₂ from CO ₂ sensor. Invalid if not connected, short or out-of-range.
	DCV STATUS	N/A	ON/OFF	DEMAND CONTROLLED VENTILATION STATUS Displays ON if above setpoint and OFF if below setpoint, and ONLY if a CO ₂ sensor is connected.
	DAMPER OUT	2.0v	2.0 to 10.0v	Displays voltage output to the damper actuator.
	ACT POS	N/A	0 to 100%	Displays actual position of outdoor air damper actuator.
	ACT COUNT	N/A	1 to 65535	Displays number of times actuator has cycled. 1 cycles equals 180 deg. of actuator movement in any direction.
	ACTUATOR	N/A	OK/Alarm (on Alarm menu)	Displays ERROR if voltage or torque is below actuator range.
	EXH1 OUT	OFF	ON/OFF	EXHAUST STAGE 1 RELAY OUTPUT Output of EXH1 terminal: ON = relay closed OFF = relay open
	EXH2 OUT	OFF	ON/OFF	EXHAUST STAGE 2 RELAY OUTPUT Output of AUX terminal; displays only if AUX = EXH2
	ERV	OFF	ON/OFF	ENERGY RECOVERY VENTILATOR Output of AUX terminal; displays only if AUX = ERV

Table 9 — W7220 Menu Structure^a (cont)

MENU	PARAMETER	PARAMETER DEFAULT VALUE	PARAMETER RANGE AND INCREMENT ^b	NOTES
STATUS (cont)	MECH COOL ON or HEAT STAGES ON	0	0, 1, or 2	Displays stage of mechanical cooling that is active. Displays the stage of heat pump heating that is active.
	FAN SPEED	N/A	LOW or HIGH	SUPPLY FAN SPEED Displays speed setting of fan on a 2-speed fan unit.
	W (HEAT ON)	N/A	ON/OFF	HEAT DEMAND STATUS Displays status of heat demand on a 2-speed fan unit.
SETPOINTS	MAT SET ^d	53°F	38°F to 70°F (3°C to 21°C); increment by 1°F	MIXED AIR SETPOINT Setpoint determines where the economizer will modulate the OA damper to maintain the mixed air temperature.
	LOW T LOCK	32°F	-45°F to 80°F (-43°C to 27°C); increment by 1°F	COMPRESSOR LOW TEMPERATURE LOCKOUT Setpoint determines outdoor temperature when the mechanical cooling cannot be turned on. Commonly referred to as the Compressor lockout.
	DRYBLB SET ^e	63°F	48°F to 80°F (9°C to 27°C); increment by 1°F	OA DRY BULB TEMPERATURE CHANGEOVER SETPOINT Setpoint determines where the economizer will assume outdoor air temperature is good for free cooling; e.g.; at 63°F unit will economize at 62°F and below and not economize at 64°F and above. There is a 2°F deadband. DRYBULB SET is only displayed if the economizer has a single dry bulb sensor.
	DRYBLB DIFF	0°F	0°F to 6°F Increment by 2°F	Drybulb Differential will only show if using dual drybulb - i.e. when an outdoor air temperature sensor C7250 is attached to OAT terminals and C7400S sensor is wired to S-Bus and configured for RAT (return air). Free cooling will be assumed whenever OA temp is at or below RAT minus this drybulb setting.
	ENTH CURVE	ES3	ES1,ES2,ES3, ES4, or ES5	ENTHALPY CHANGEOVER CURVE (Requires enthalpy sensor option) Enthalpy boundary "curves" for economizing using single enthalpy.
	DCV SET	1100ppm	500 to 2000 ppm; increment by 100	DEMAND CONTROLLED VENTILATION SETPOINT Displays only if CO ₂ sensor is connected. Setpoint for Demand Controlled Ventilation of space. Above the setpoint, the OA dampers will modulate open to bring in additional OA to maintain a space ppm level below the setpoint.
	MIN POS	4.4 V	2 to 10 Vdc	VENTILATION MINIMUM POSITION. Only displayed if controller is set for single speed unit under FAN TYPE, and if DCV is NOT used.
	MIN POS L	6.0 V	2 to 10 Vdc	VENTILATION MINIMUM POSITION AT LOW SPEED. Only displays if unit is set for 2 or 3 speed and CO ₂ is not used. If using 2 speed with 1 heat and 1 cool then set for HEATING ventilation. If using 3 speed with 1 heat and 2 cool then set for LOW SPEED COOLING ventilation.
	MIN POS M	5.4 V	2 to 10 Vdc	VENTILATION MINIMUM POSITION AT MEDIUM SPEED. Only displays if unit is set for 3 speed with 1 heat and 2 cool, and CO ₂ is not used. Set for HEATING ventilation.
	MIN POS H	4.4 V	2 to 10 Vdc	VENTILATION MINIMUM POSITION AT HIGH SPEED. Only displays if unit is set for 2 or 3 speed and CO ₂ is not used. IF using 2 speed with 1 heat and 1 cool then set for COOLING ventilation. If using 3 speed with 1 heat and 2 cool then set for HIGH SPEED COOLING ventilation.
	VENTMAX L	6.0V	2 to 10 Vdc	DCV MAXIMUM DAMPER POSITION AT LOW SPEED. Only displays if unit is set for 2 speed or 3 speed with 1 heat and 2 cool. IF using 2 speed with 1 heat and 1 cool then set for HEATING ventilation. If using 3 speed with 1 heat and 2 cool then set for LOW SPEED COOLING.
	VENTMAX M	5.4 V	2 to 10 Vdc	DCV MAXIMUM DAMPER POSITION AT MEDIUM SPEED. Only displays if unit is set for 3 speed with 1 heat and 2 cool. Set for HEATING ventilation.
	VENTMAX H	4.4 V	2 to 10 Vdc	DCV MAXIMUM DAMPER POSITION AT HIGH SPEED. Only displays if unit is set for 2 speed or 3 speed with 1 heat and 2 cool. IF using 2 speed with 1 heat and 1 cool then set for COOLING ventilation. If using 3 speed with 1 heat and 2 cool then set for HIGH SPEED COOLING ventilation.
	VENTMIN L	3.7 V	2 to 10 Vdc	DCV MINIMUM DAMPER POSITION AT LOW SPEED. Only displays if unit is set for 2 speed or 3 speed with 1 heat and 2 cool. IF using 2 speed with 1 heat and 1 cool then set for HEATING ventilation. If using 3 speed with 1 heat and 2 cool then set for LOW SPEED COOLING.
	VENTMIN M	3.4 V	2 to 10 Vdc	DCV MINIMUM DAMPER POSITION AT MEDIUM SPEED. Only displays if unit is set for 3 speed with 1 heat and 2 cool. Set for HEATING ventilation.
VENTMIN H	2.8 V	2 to 10 Vdc	DCV MINIMUM DAMPER POSITION AT HIGH SPEED. Only displays if unit is set for 2 speed or 3 speed with 1 heat and 2 cool. IF using 2 speed with 1 heat and 1 cool then set for COOLING ventilation. If using 3 speed with 1 heat and 2 cool then set for HIGH SPEED COOLING ventilation.	

Table 9 — W7220 Menu Structure^a (cont)

MENU	PARAMETER	PARAMETER DEFAULT VALUE	PARAMETER RANGE AND INCREMENT ^b	NOTES
SETPOINTS (cont)	ERV OAT SP ^f	32°F	0°F to 50°F (-18°C to 10°C); increment by 1°F	ENERGY RECOVERY VENTILATOR UNIT OUTDOOR AIR TEMPERATURE SETPOINT Only displayed when AUX1 O = ERV
	EXH1 SET	50%	0 to 100%	Exhaust fan set point for single speed units. Based on OA Damper position to activate power exhaust.
	EXH1 L SET	65%	0 to 100%	EXHAUST FAN 1 SETPOINT AT LOW SPEED on 2 speed or 3 speed with 1 heat and 2 cool. Based on economizer OA damper position to activate power exhaust.
	EXH1 M SET	60%	0 to 100%	EXHAUST POINT 1 SETPOINT AT MEDIUM SPEED. Only displays if unit is set for 3 speed with 1 heat and 2 cool. Based on economizer OA damper position to activate power exhaust.
	EXH1 H SET	50%	0 to 100%	EXHAUST FAN 1 SETPOINT AT HIGH SPEED on 2 speed or 3 speed with 1 heat and 2 cool. Based on economizer OA damper position to activate power exhaust.
	EXH2 L SET	80%	0 to 100%	EXHAUST FAN 2 SETPOINT AT LOW SPEED on 2 speed or 3 speed with 1 heat and 2 cool. Based on economizer OA damper position to activate power exhaust.
	EXH2 M SET	77%	0 to 100%	EXHAUST FAN 2 SETPOINT AT MEDIUM SPEED. Only displays if unit is set for 3 speed with 1 heat and 2 cool. Based on economizer OA damper position to activate power exhaust.
	EXH2 H SET	75%	0 to 100%	EXHAUST FAN 2 SETPOINT AT HIGH SPEED on 2 speed or 3 speed with 1 heat and 2 cool. Based on economizer OA damper position to activate power exhaust.
SYSTEM SETUP	INSTALL	01/01/17	N/A	Display order = MM/DD/YY Setting order = DD, MM, then YY.
	UNITS DEG	F	F or C	Sets economizer controller in degrees Fahrenheit or Celsius.
	EQUIPMENT	CONV	Conventional or HP	CONV = conventional; HP O/B = Enable Heat Pump mode. Use AUX2 I for Heat Pump input from thermostat or controller. ⁹
	AUX2 IN	W	SD/W or HP(O)/HP(B)	In CONV mode: SD + Enables configuration of shutdown (default); W = Informs controller that system is in heating mode. NOTE: If using 2-speed fan mode, you must program CONV mode for W. Shutdown is not available in 2-speed fan mode. ⁹ In HP O/B mode: HP(O) = energize heat pump on Cool (default); HP(B) = energize heat pump on heat.
	FAN SPEED	2 speed	1 speed 2 speed 2SP H/C 3 speed	Sets the economizer controller operation based on 1 speed, 2 speed, 2 speed heat/cool (2SP H/C), or 3 speed supply fan. NOTE: Multi-speed fan options also need Heat (W1) programmed in AUX 2 In. ⁹
	FAN CFM	5000cfm	100 to 15000 cfm; increment by 100	UNIT DESIGN AIRFLOW (CFM) Enter only if using DCVAL ENA = AUTO The value is found on the nameplate label for the specific unit.
	AUX1 OUT	NONE	NONE ERV EXH2 SYS	Select OUTPUT for AUX1 O relay • NONE = not configured (output is not used) • ERV = Energy Recovery Ventilator ^f • EXH2 = second damper position relay closure for second exhaust fan • SYS = use output as an alarm signal
	OCC	INPUT	INPUT or ALWAYS	OCCUPIED MODE BY EXTERNAL SIGNAL When using a setback thermostat with occupancy out (24 vac), the 24 vac is input "INPUT" to the OCC terminal. If no occupancy output from the thermostat then change program to "ALWAYS" OR add a jumper from terminal R to OCC terminal.
	FACTORY DEFAULT	NO	NO or YES	Resets all set points to factory defaults when set to YES. LCD will briefly flash YES and change to NO but all parameters will change to the factory default values. NOTE: RECHECK AUX2 IN and FANTYPE for required 2-speed values.
ADVANCED SETUP	MA LO SET	45°F	35°F to 55°F (2°C to 13°C); Incremented by 10°F	SUPPLY AIR TEMPERATURE LOW LIMIT Temperature to achieve Freeze Protection (close damper and alarm if temperature falls below setup value).
	FREEZE POS	CLO	CLO or MIN	FREEZE PROTECTION DAMPER POSITION Damper position when freeze protection is active (closed or MIN POS).
	CO2 ZERO	0ppm	0 to 500 ppm; Increment by 10	CO ₂ ppm level to match CO ₂ sensor start level.
	CO2 SPAN	2000ppm	1000 to 3000 ppm; Increment by 10	CO ₂ ppm span to match CO ₂ sensor.

Table 9 — W7220 Menu Structure^a (cont)

MENU	PARAMETER	PARAMETER DEFAULT VALUE	PARAMETER RANGE AND INCREMENT ^b	NOTES
ADVANCED SETUP (cont)	STG3 DLY	2.0h	0 min, 5 min, 15 min, then 15 min intervals. Up to 4 hrs or OFF	COOLING STAGE 3 DELAY Delay after stage 2 cool has been active. Turns on second stage of cooling when economizer is first stage and mechanical cooling is second stage. Allows three stages of cooling, 1 economizer and 2 mechanical. OFF = no Stage 3 cooling
	SD DMPR POS	CLO	CLO or OPN	Indicates shutdown signal from space thermostat or unitary controller. When controller receives 24 Vac input on the SD terminal in conventional mode, the OA damper will open if programmed for OPN and OA damper will close if programmed for CLO. All other controls, e.g., fans, etc. will shut off.
	DA LO ALM	45°F (7°C)	35°F to 65°F (2°C to 18°C); Incremented by 5°F.	Used for alarm for when the DA air temperature is too low. Set lower range of alarm, below this temperature the alarm will show on the display.
	DA HI ALM	80°F (27°C)	70°F to 180°F (21°C to 82°C); Incremented by 5°F	Used for alarm for when the DA air temperature is too high. Set upper range of alarm, above this temperature the alarm will show on the display.
	DCVCAL ENA	MAN	MAN (manual) AUTO	Turns on the DCV automatic control of the dampers. Resets ventilation based on the RA, OA, and MA sensor conditions. Requires all 3 RA, OA, and MA sensors.
	MAT T CAL	0.0°F	±2.5°F	SUPPLY AIR TEMPERATURE CALIBRATION Allows for the operator to adjust for an out of calibration temperature sensor.
	OAS T CAL	0.0°F	±2.5°F	OUTSIDE AIR TEMPERATURE CALIBRATION Allows for the operator to adjust for an out of calibration temperature sensor.
	OA H CAL	0% RH	±10% RH	OUTSIDE AIR HUMIDITY CALIBRATION Allows for operator to adjust for an out of calibration humidity sensor.
	RA T CAL	0.0°F	±2.5°F	RETURN AIR TEMPERATURE CALIBRATION Allows for the operator to adjust for an out of calibration temperature sensor.
	RA H CAL	0% RH	±10% RH	RETURN AIR HUMIDITY CALIBRATION Allows for operator to adjust for an out of calibration humidity sensor.
	DA T CAL	0.0°F	±2.5°F	DISCHARGE AIR TEMPERATURE CALIBRATION Allows for the operator to adjust for an out of calibration temperature sensor.
	2SP FAN DELAY	5 Minutes	0 to 20 minutes in 1 minute increments	TIME DELAY ON SECOND STAGE ECONOMIZING When in economizing mode this is the delay for the high speed fan to try to satisfy the call for second stage cooling before the first stage mechanical cooling is enabled.
CHECKOUT	DAMPER MINIMUM POSITION	N/A	N/A	The checkout for the damper minimum position is based on the system.
	DAMPER OPEN	N/A	N/A	Position damper to the full open position. Exhaust fan contacts enable during the DAMPER OPEN test. Make sure you pause in the mode to allow exhaust contacts to energize due to the delay in the system.
	DAMPER CLOSE	N/A	N/A	Positions damper to the fully closed position
	CONNECT Y1-O	N/A	N/A	Closes the Y1-O relay (Y1-O)
	CONNECT Y2-O	N/A	N/A	Closes the Y2-O relay (Y2-O)
	CONNECT AUX1-O	N/A	N/A	Energizes the AUX output. If Aux setting is: • NONE — not action taken • ERV — 24 Vac out. Turns on or signals an ERV that the conditions are not good for economizing but are for ERV operation. ^f • SYS — 24 Vac out. Issues a system alarm.
CONNECT EXH1	N/A	N/A	Closes the power exhaust fan 2 relay (EXH1)	
ALARMS	Alarms display only when they are active. The menu title "ALARMS(#)" includes the number of active alarms in parenthesis (). When using SYLK bus sensors, "SYLK" will appear on the screen, and when using 20k OA temperature sensors, "SENS T" will appear on the screen.			
	MA T SENS ERR	N/A	N/A	SUPPLY AIR TEMPERATURE SENSOR ERROR Mixed air sensor has failed or become disconnected - check wiring then replace sensor if the alarm continues.
	CO2 SENS ERR	N/A	N/A	CO ₂ SENSOR ERROR CO ₂ sensor has failed, gone out of range or become disconnected - check wiring then replace sensor if the alarm continues.
	OA SYLK T ERR	N/A	N/A	OUTSIDE AIR S-BUS SENSOR ERROR Outdoor air enthalpy sensor has failed or become disconnected - check wiring then replace sensor if the alarm continues.
	OA SYLK H ERR	N/A	N/A	
	RA SYLK T ERR	N/A	N/A	RETURN AIR S-BUS SENSOR ERROR Return air enthalpy sensor has failed or become disconnected - check wiring then replace sensor if the alarm continues.
	RA SYLK H ERR	N/A	N/A	

Table 9 — W7220 Menu Structure^a (cont)

MENU	PARAMETER	PARAMETER DEFAULT VALUE	PARAMETER RANGE AND INCREMENT ^b	NOTES
ALARMS (cont)	DA SYLK T ERR	N/A	N/A	DISCHARGE AIR S-BUS SENSOR ERROR Discharge air sensor has failed or become disconnected - check wiring then replace sensor if the alarm continues.
	OA SENS T ERR	N/A	N/A	OUTSIDE AIR TEMPERATURE SENSOR ERROR Outdoor air temperature sensor has failed or become disconnected - check wiring then replace if the alarm continues.
	ACT ERROR	N/A	N/A	ACTUATOR ERROR Actuator has failed or become disconnected - check for stall, over voltage, under voltage and actuator count. Replace actuator if damper is movable and supply voltage is between 21.6 V and 26.4 V. Check actuator count on STATUS menu.
	FREEZE ALARM	N/A	N/A	Check if outdoor temperature is below the LOW Temp Lockout on setpoint menu. Check if Mixed air temperature on STATUS menu is below the Lo Setpoint on Advanced menu. When conditions are back in normal range then the alarm will go away.
	SHUTDOWN ACTIVE	N/A	N/A	AUX2 IN is programmed for SHUTDOWN and 24 V has been applied to AUX2 IN terminal.
	DMP CAL RUNNING	N/A	N/A	DAMPER CALIBRATION ROUTINE RUNNING If DCV Auto enable has been programmed, when the W7220 is completing a calibration on the dampers, this alarm will display. Wait until the calibration is completed and the alarm will go away. Must have OA, MA and RA sensors for DCV calibration; set up in the Advanced setup menu.
	DA SENS ALM	N/A	N/A	DISCHARGE AIR TEMPERATURE SENSOR ALARM Discharge air temperature is out of the range set in the ADVANCED SETUP Menu. Check the temperature of the discharge air.
	SYS ALARM	N/A	N/A	When AUX1-O is set to SYS and there is any alarm (e.g., failed sensors, etc.), the AUX1-O terminal has 24 Vac out.
	ACT UNDER V	N/A	N/A	ACTUATOR VOLTAGE LOW Voltage received by actuator is above expected range.
	ACT OVER V	N/A	N/A	ACTUATOR VOLTAGE HIGH Voltage received by actuator is below expected range.
	ACT STALLED	N/A	N/A	ACTUATOR STALLED Actuator stopped before achieving commanded position.

NOTE(S):

- a. Table 9 illustrates the complete hierarchy. Your menu parameters may be different depending on your configuration. For example if you do not have a DCV (CO₂) sensor, then none of the DCV parameters appear.
- b. When values are displayed, pressing and holding the ▲ or ▼ button causes the display to automatically increment.
- c. STATUS → OCCUPIED — The factory-standard Occupancy signal originates with a thermostat or other controller call for indoor fan operation at UCB terminal G. This signal passes through the Unit Control Board's OCCUPIED jumper JMP1 to the ECONO connector and to the W7220's OCC input terminal. An external timeclock or relay is required to implement an Occupancy schedule on the economizer damper position.
- d. STATUS → MA TEMP, SETPOINTS → MAT SET — The W7220 menu parameters and labels include designations MA, MAT, and Mixed Air for the economizer cooling control sensor. On these rooftop units, the economizer control sensor is located downstream of the evaporator/indoor coil in the supply fan section where this sensor is designated as Supply Air Temperature (SAT) sensor.
- e. SETPOINTS → DRYBLB SET — This point is not displayed if a Return Air (differential) temperature sensor or an Outdoor Air enthalpy sensor is connected.
- f. ERV Operation: When in cooling mode AND the conditions are NOT OK for economizing - the ERV terminal will be energized. In the Heating mode, the ERV terminal will be energized when the OA is below the ERV OAT set point in the set point menu.
- g. SYSTEM SETUP parameters must be configured as noted for Multi-Speed unit operation:
EQUIPMENT = CONV
AUX2 IN = W
FAN SPEED = 2SPEED

LEGEND

- CLO** — Compressor Lockout
- ERV** — Energy Recovery Ventilator
- LCD** — Liquid Crystal Display
- MA** — Mixed Air
- MAT** — Mixed Air Temperature
- N/A** — Not Applicable
- OA** — Outdoor Air
- OAT** — Outdoor Air Temperature
- OCC** — Occupied
- RA** — Return Air
- RAT** — Return Air Temperature
- RTU** — Rooftop Unit
- SYS** — System

STANDARD OR SINGLE SPEED FAN OPERATION
 FAN TYPE = 1 SPEED is not used on 50FCQ*17-28 units.

2 SPEED FAN OPERATION

The W7220 controller has the capability to work with a system using a 2-speed supply fan. The W7220 does not control the supply directly but uses the following input status to determine the speed of the supply fan and controls the OA damper to the required position, see Table 10.

Table 10 — Fan Speed

STATE	FAN SPEED
OCC	Low
Y1	Low
Y2	High
W	High

The W (heating mode) is not controlled by the W7220 but it requires the status to know where to position the OA damper for minimum position for the fan speed.

The 2 speed fan delay is available when the system is programmed for 2 speed fan (in the System Setup menu item). The 2 speed fan delay is defaulted to 5 minutes and can be changed in the Advanced Setup menu item. When the unit has a call for Y1 In and in the free cooling mode and there is a call for Y2 In, the 2-speed fan delay starts and the OA damper will modulate 100% open, the supply fan should be set to high speed by the unit controller.

After the delay, one of two actions will happen:

- The Y2 In call will be satisfied with the damper 100% open and fan on high speed and the call will turn off

OR

- If the call for additional cooling in the space has not been satisfied then the first stage of mechanical cooling will be enabled through Y1 Out or Y2 Out.

Refer to Table 11 for economizer operation.

Table 11 — Economizer Operation — FAN TYPE = 2SPEED

INPUTS		OUTPUTS							
DEMAND CONTROLLED VENTILATION (DCV)	OUTSIDE AIR GOOD TO ECONOMIZE	W (HEAT ON)	COOL Y1-IN	COOL Y2-IN	COOL Y1-OUT	COOL Y2-OUT	FAN SPEED (reference only)	DAMPER POSITION	
								OCCUPIED	UNOCCUPIED
NONE	NO	ON	N/A	N/A	OFF	OFF	HIGH	MIN POS H	Closed
		OFF	OFF	OFF	OFF	OFF	LOW	MIN POS L	Closed
		OFF	ON	OFF	ON	OFF	LOW	MIN POS L	Closed
		OFF	ON	ON	ON	ON	HIGH	MIN POS H	Closed
	YES	ON	N/A	N/A	OFF	OFF	HIGH	MIN POS H	Closed
		OFF	OFF	OFF	OFF	OFF	LOW	MIN POS L	Closed
		OFF	ON	OFF	OFF	OFF	LOW	MIN POS L to Full Open	Closed to Full Open
		OFF	ON	ON	ON	OFF ^a	HIGH	MIN POS H to Full Open	Closed to Full Open
Below CO ₂ Set	NO	ON	N/A	N/A	OFF	OFF	HIGH	VENTMIN H	Closed
		OFF	OFF	OFF	OFF	OFF	LOW	VENTMIN L	Closed
		OFF	ON	OFF	ON	OFF	LOW	VENTMIN L	Closed
		OFF	ON	ON	ON	ON	HIGH	VENTMIN H	Closed
	YES	ON	N/A	N/A	OFF	OFF	HIGH	VENTMIN H	Closed
		OFF	OFF	OFF	OFF	OFF	LOW	VENTMIN L	Closed
		OFF	ON	OFF	OFF	OFF	LOW	VENTMIN L to Full Open	Closed to Full Open
		OFF	ON	ON	ON	OFF ^a	HIGH	VENTMIN H to Full Open	Closed to Full Open
Above CO ₂ Set	NO	ON	N/A	N/A	OFF	OFF	HIGH	VENTMIN H to VENTMAX H	Closed
		OFF	OFF	OFF	OFF	OFF	LOW	VENTMIN L to VENTMAX L	Closed
		OFF	ON	OFF	ON	OFF	LOW	VENTMIN L to VENTMAX L	Closed
		OFF	ON	ON	ON	ON	HIGH	VENTMAX H to VENTMAX H	Closed
	YES	ON	N/A	N/A	OFF	OFF	HIGH	VENTMIN H to VENTMAX H	Closed
		OFF	OFF	OFF	OFF	OFF	LOW	VENTMIN L to VENTMAX L	Closed
		OFF	ON	OFF	OFF	OFF ^a	LOW	VENTMIN L to Full Open	Closed to Full Open
		OFF	ON	ON	ON	OFF ^a	HIGH	VENTMIN H to Full Open	Closed to Full Open

NOTE(S):

a. With stage 3 delay (STG3 DLY) in Advanced setup, COOL Y2-OUT will be turned ON after the delay time specified.

LEGEND

N/A — Not Applicable

2SP H/C (2 SPEED HEAT/COOL) SPEED FAN OPERATION
 FAN TYPE = 2SP H/C is not used on 50FCQ*17-28 units

3 SPEED FAN OPERATION
 FAN TYPE = 3SPEED is not used on 50FCQ*17-28 units

ENTHALPY SETTINGS

When the OA temperature, enthalpy and dew point are below the respective set points, the Outdoor Air can be used for economizing. Figure 67 shows the new single enthalpy boundaries in the W7220. There are 5 boundaries (set points ES1 through ES5), which are defined by dry bulb temperature, enthalpy and dew point.

Refer to Table 12 for ENTH CURVE set point values.

The W7220 calculates the enthalpy and dew point using the OA temperature and humidity input from the OA enthalpy sensor. When the OA temperature, OA humidity and OA dew point are all below the selected boundary, the economizer sets the economizing mode to YES, economizing is available.

When all of the OA conditions are above the selected boundary, the conditions are not good to economize and the mode is set to NO.

Figure 67 shows the 5 current boundaries. There is also a high limit boundary for differential enthalpy. The high limit boundary is ES1 when there are no stages of mechanical cooling energized and HL (high limit) when a compressor stage is energized.

Table 12 provides the values for each boundary limit.

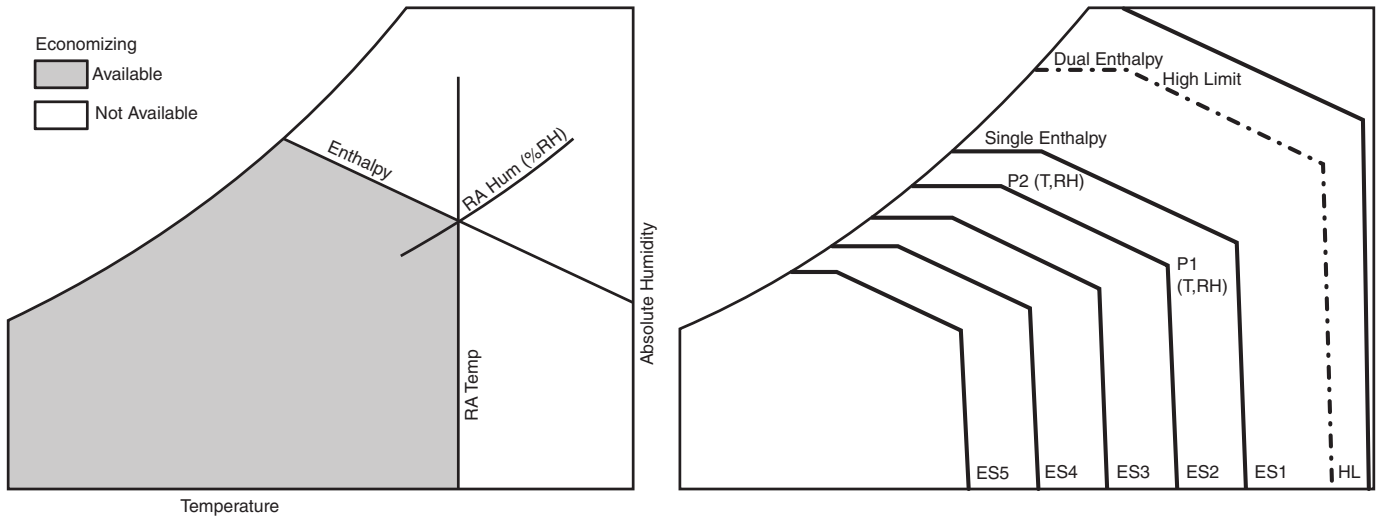

Fig. 67 — Single Enthalpy Curve Boundaries

Table 12 — Single Enthalpy and Dual Enthalpy High Limit Curves

ENTHALPY CURVE	TEMP. DRY BULB (°F)	TEMP. DEWPOINT (°F)	ENTHALPY (btu/lb/da)	POINT P1		POINT P2	
				TEMP. (°F)	HUMIDITY (%RH)	TEMP. (°F)	HUMIDITY (%RH)
ES1	80	60	28.0	80	36.8	66.3	80.1
ES2	75	57	26.0	75	39.6	63.3	80.0
ES3	70	54	24.0	70	42.3	59.7	81.4
ES4	65	51	22.0	65	44.8	55.7	84.2
ES5	60	48	20.0	60	46.9	51.3	88.5
HL	86	66	32.4	86	38.9	72.4	80.3

CHECKOUT

Inspect all wiring connections at the economizer module's terminals, and verify compliance with the installation wiring diagrams.

For checkout, review the Status of each configured parameter and perform the Checkout tests.

NOTE: For information about menu navigation and use of the keypad, see Interface Overview on page 43.

⚠ WARNING

ELECTRIC SHOCK HAZARD

Failure to follow this warning could result in personal injury, property damage, or death.

Before performing service or maintenance operations on unit, always turn off main power switch to unit and install lock(s) and lockout tag(s). Unit may have more than one power switch. Ensure electrical service to rooftop unit agrees with voltage and amperage listed on the unit rating plate.

If any wiring changes are required, first be sure to remove power from the economizer module before starting work. Pay particular attention to verifying the power connection (24 vac).

Power Up

After the W7220 module is mounted and wired, apply power.

Initial Menu Display

On initial start up, Honeywell displays on the first line and Economizer W7220 on the second line. After a brief pause, the revision of the software appears on the first line and the second line will be blank.

Power Loss (Outage or Brownout)

All set points and advanced settings are restored after any power loss or interruption.

NOTE: All settings are stored in non-volatile flash memory.

Status

Use the Status menu (see Table 9) to check the parameter values for the various devices and sensors configured.

NOTE: For information about menu navigation and use of the keypad, see Interface Overview on page 43.

Checkout Tests

Use the Checkout menu (on page 48) to test the damper operation and any configured outputs. Only items that are configured are shown in the Checkout menu.

NOTE: For information about menu navigation and use of the keypad, see Interface Overview on page 43.

To perform a Checkout test:

1. Scroll to the desired test in the Checkout menu using the ▲ and ▼ buttons.
2. Press the ↵ (Enter) button to select the item.
3. RUN? appears.
4. Press the ↵ (Enter) button to start the test.
5. The unit pauses and then displays IN PROGRESS.
6. When the test is complete, DONE appears.
7. When all desired parameters have been tested, press the ⏪ (Menu Up) button to end the test.

The Checkout tests can all be performed at the time of installation or at any time during the operation of the system as a test that the system is operable.

⚠ CAUTION

EQUIPMENT DAMAGE HAZARD

Failure to follow this caution may result in equipment damage.

Be sure to allow enough time for compressor start-up and shutdown between checkout tests so that you do not short-cycle the compressors.

TROUBLESHOOTING

Alarms

The economizer module provides alarm messages that display on the 2-line LCD.

NOTE: Upon power up, the module waits 60 minutes before checking for alarms. This allows time for all the configured devices (e.g. sensors, actuator) to become operational. The exception is the SAT sensor which will alarm immediately.

If one or more alarms are present and there has been no keypad activity for at least 5 minutes, the Alarms menu displays and cycles through the active alarms.

You can also navigate to the Alarms menu at any time.

Clearing Alarms

Once the alarm has been identified and the cause has been removed (e.g. replaced faulty sensor) the alarm can be cleared from the display.

To clear an alarm, perform the following:

1. Navigate to the desired alarm.
2. Press the ↵ (Enter) button. ERASE? displays.
3. Press the ↵ (Enter) button. ALARM ERASED displays.
4. Press the ⏪ (Menu up/Exit) button to complete the action and return to the previous menu.

NOTE: If the alarm still exists after clearing it, it is redisplayed within 5 seconds.

⚠ CAUTION

EQUIPMENT DAMAGE HAZARD

Failure to follow this caution may result in equipment damage.

Be sure to allow enough time for compressor start-up and shutdown between checkout tests so that you do not short-cycle the compressors.

SystemVu™ Controller (Factory Option)

For details on operating 50FCQ*17-28 units equipped with the factory-installed SystemVu controller option, refer to the *FC/GC Series Single Package Rooftop Units with SystemVu Controller Controls, Start-up, Operation and Troubleshooting* manual.

Smoke Detectors

Smoke detectors are available as factory-installed options on 50FCQ models. Smoke detectors may be specified for supply air only, for return air without or with economizer, or in combination of supply air and return air. Return-air smoke detectors are arranged for vertical return configurations only. The unit is factory-configured for immediate smoke detector shutdown operation; additional wiring or modifications to unit terminal board may be necessary to complete the unit and smoke detector configuration to meet project requirements.

ADDITIONAL APPLICATION DATA

Refer to the *Factory-Installed Smoke Detectors for Small and Medium Rooftop Units 2 to 25 Tons* application data for discussions on additional control features of these smoke detectors including multiple unit coordination.

EconoMi\$er X Occupancy Switch

If external occupancy control is desired, connect a time clock or remotely controlled switch (closed for Occupied, open for Unoccupied sequence) at terminals marked OCCUPANCY. Detach the jumper covering the “Occupancy” terminals on the UCB and then attach the required connections.

Step 12 — Install Accessories

Available accessories include:

- Roof curb
- Thru-base connection kit (must be installed before unit is set on curb)
- Manual outside air damper
- Two-position motorized outside air damper
- EconoMi\$er[®]2 (without control/for external signal)
- Power exhaust
- Outdoor enthalpy sensor
- Differential enthalpy sensor
- CO₂ sensor
- Louvered hail guard
- Low ambient kit
- Phase monitor control

Refer to separate installation instructions for information on installing these accessories.

Step 13 — Fan Speed Set Up

These units contain two vane axial fan assemblies. Both fans operate from the same 0-10 Vdc signal. Units in the downshot supply (vertical) duct configuration will operate both fans at the same speed setting. In units with a horizontal duct configuration the fans will operate at two different speeds. The fan closest to the control box will operate the user defined speed setting. The fan closest to the supply duct opening will operate at a lower speed that is a predetermined and non-configurable offset from the user speed setting.

NOTE: The indoor fan motors are equipped with internal protection relays designed to disable unit operation when a problem is detected. See Typical Wiring Diagram (Fig. 50) for the red wires in the Indoor fan plug.

Units with two fan motors are wired to connect the motor protection relays in series. If one motor detects a problem, both motors shut down and unit operation is disabled.

UNITS WITH ELECTRO-MECHANICAL CONTROLS

The fan speed set up controls are located on the lower section of the Unit Control Board (UCB). See Fig. 68.

1. Check the job specifications for the CFM (cubic feet per minute) and ESP (external static pressure) required.
2. Using the chart on the Fan Speed Set Up labels (see Fig. 69), calculate the Vdc from the CFM and ESP for the base unit. Then add Vdc for any accessories installed per the “Field Accessories” section of the label.

NOTE: The Fan Speed Set Up labels are located on the High Voltage cover in the Control Box.

3. Connect a multimeter to the Vdc terminals on the UCB.
4. Set the Range Switch to either A, B, or C per the Switch Range table.

5. Using a straight blade screwdriver, turn the Vdc control dial to fine tune the Vdc reading.

6. Record the reading in the Field Setting field.

NOTE: Fan set-up Vdc is not affected by the operating stage of the unit.

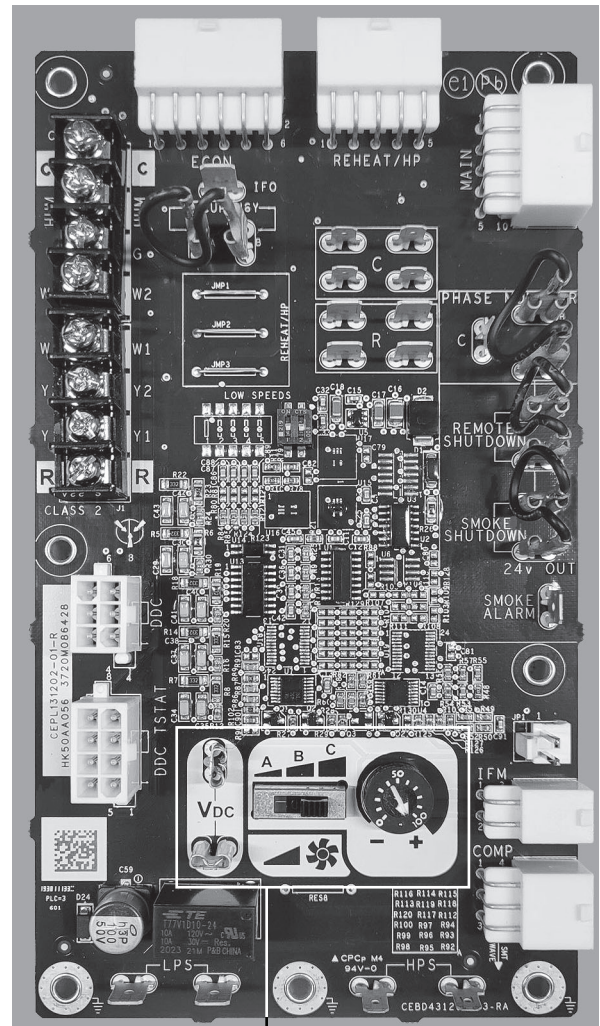
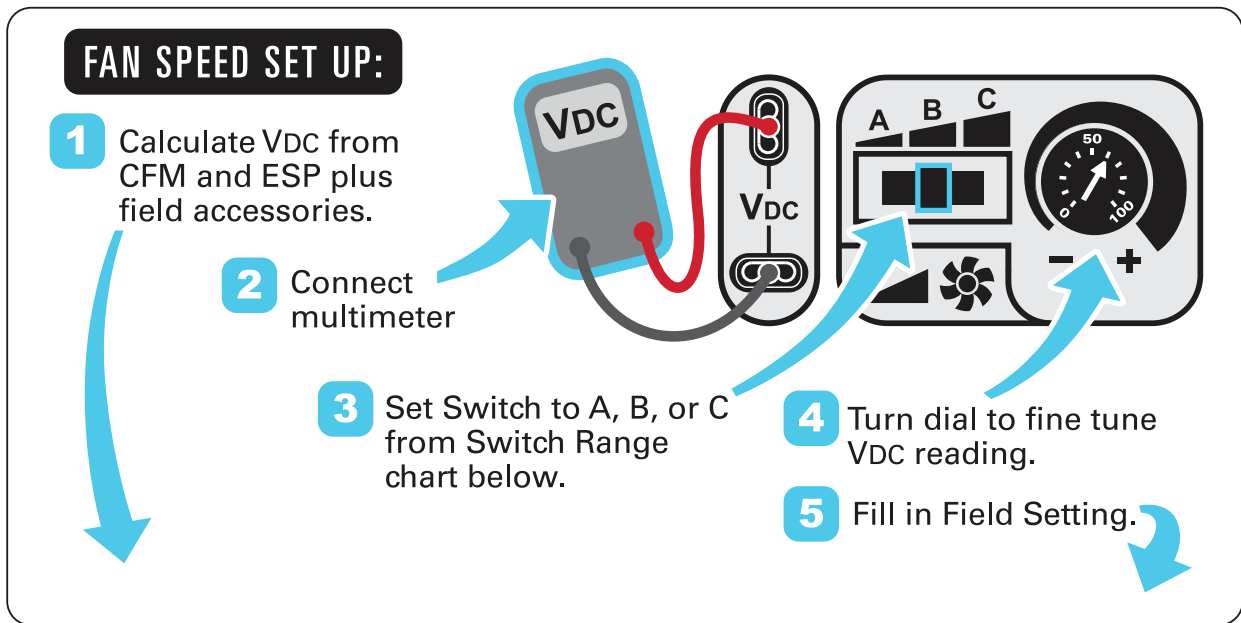

Fig. 68 — UCB Fan Speed Controls



VDC Calculator		ESP in. wg										
		0.2	0.4	0.6	0.8	1.0	1.2	1.4	1.6	1.8	2.0	
UNIT MODEL NUMBER	CFM	6000	5.6	6.1	6.5	6.9	7.3	7.6	8.0	8.3	8.6	8.9
		6500	6.0	6.4	6.8	7.2	7.6	7.9	8.3	8.6	8.9	9.2
		7000	6.4	6.8	7.2	7.6	7.9	8.2	8.6	8.9	9.2	9.5
		7500	6.8	7.2	7.5	7.9	8.2	8.6	8.9	9.2	9.5	9.7
		8000	7.2	7.6	7.9	8.2	8.6	8.9	9.2	9.5	9.8	
		8500	7.6	8.0	8.3	8.6	8.9	9.2	9.5	9.8		
		9000	8.0	8.4	8.7	9.0	9.3	9.6	9.8			
		9500	8.5	8.8	9.1	9.3	9.6	9.9				
		10000	8.9	9.2	9.4	9.7	10.0					
	Field Accessories:											
	Economizer	0.4	0.4	0.4	0.4	0.4	0.4	0.4	0.4	0.4	0.4	0.4

Factory Setting:
9.0 VDC

Field Setting:
Record field setting here
_____ VDC

Switch Range: *

	A	B	C
A	4.1 - 7.5		
B	6.9 - 8.7		
C	7.7 - 10.0		

* Overlap in A, B, C switch range designed for maximum field adjustment potential. For example 7.2 can be set at either A or B.

NOTE: Values in the Field Accessories section are VDC adders.

Fig. 69 — Example of Fan Speed Set Up Labels for Electro-Mechanical Controls

UNITS WITH SYSTEMVU™ CONTROLS

On units equipped with the factory-installed SystemVu controller, the Fan Speed settings are accessed through the SystemVu interface.

1. Check the job specifications for the CFM (cubic feet per minute) and ESP (external static pressure) required.
2. Using the chart on the Fan Speed Set Up labels (see Fig. 70), calculate the RPM from the CFM and ESP for the base unit plus any field accessories (as listed on the label).

NOTE: The Fan Speed Set Up labels are located on the High Voltage cover in the Control Box.

3. Press any key on the SystemVu interface to activate the display backlight and then press the MENU key.
4. Using the UP and DOWN arrow keys highlight SETTINGS and then press ENTER.

5. Use the DOWN arrow key highlight the UNIT CONFIGURATIONS menu then press ENTER.
6. Highlight UNIT CONFIGURATIONS then press ENTER.
7. Highlight INDOOR FAN and then press ENTER.
8. Refer to the job specifications to set the following, determining the values per the RPM Calculator label (see Fig. 70). Use the UP and DOWN arrow keys and the BACK key to set the values. Press ENTER after setting each value to continue to the next selection.
 - IDF VENT SPD
 - IDF HEAT SPD
 - IDF HIGH COOL SPD
 - IDF FREE COOL SPD

For further details, see the *FC/GC Series Single Package Rooftop Units with SystemVu Controller Controls, Start-up, Operation and Troubleshooting* manual.

FAN SPEED SETUP (RPM)

MAIN MENU:

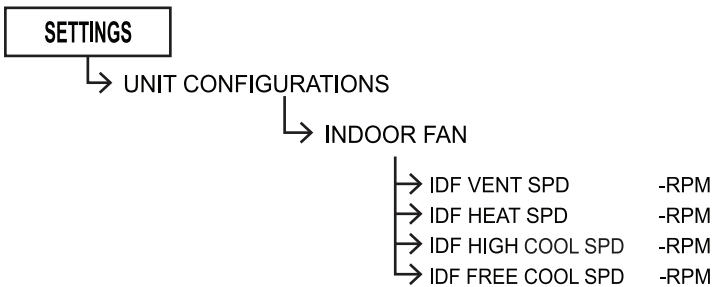

↓ DETERMINE RPM FROM BELOW ↓

48TC003136 REV. B

RPM Calculator

		ESP in. wg									
		0.2	0.4	0.6	0.8	1.0	1.2	1.4	1.6	1.8	2.0
UNIT MODEL NUMBER	CFM										
	6000	1250	1348	1441	1528	1610	1688	1762	1832	1899	1963
	6500	1336	1428	1515	1598	1677	1753	1824	1893	1959	2021
	7000	1423	1509	1591	1670	1746	1819	1888	1955	2020	2081
	7500	1510	1591	1669	1744	1817	1887	1954	2019	2082	2143
	8000	1598	1675	1749	1820	1890	1957	2022	2085	2146	
	8500	1687	1759	1829	1898	1964	2029	2092	2153		
	9000	1776	1845	1912	1977	2041	2103	2163			
	9500	1866	1931	1995	2057	2118	2178				
	10000	1955	2018	2079	2138	2197					
Field Accessories:											
	Economizer	89	89	89	89	89	89	89	89	89	89

NOTE: Values in the Field Accessories section are VDC adders.

Fig. 70 — Example of Fan Speed Set Up Labels for SystemVu™ Controls

Typical Unit Piping

Each heat pump system includes two compressors, a reversing valve, dual-function outdoor and indoor coils, a common liquid line with bi-flow TXV, and dedicated cooling and heating TXVs. 50FCQ*17-28 unit indoor coils contain a vapor header check valve. See Fig. 71-74 and Tables 13-21 for typical unit piping schematic parallel coil circuits during evaporator-function operation and converging coil circuits during the condenser-function operation.

Table 13 — 50FCQ*17 – Cooling Mode

COMPONENT	STATUS/POSITION
Reversing Valve	Energized
Check Valve A	Closed
Check Valve B	Closed
Check Valve C	Open
Check Valve D	Open
Check Valve E	Open
Check Valve F	Closed
Check Valve G	Closed
Check Valve H	Open

Table 14 — 50FCQ*17 – Heating Mode

COMPONENT	STATUS/POSITION
Reversing Valve	De-energized
Check Valve A	Open
Check Valve B	Open
Check Valve C	Closed
Check Valve D	Closed
Check Valve E	Closed
Check Valve F	Open
Check Valve G	Open
Check Valve H	Closed

Table 15 — 50FCQ*17 – Defrost Mode

COMPONENT	STATUS/POSITION
Defrost Thermostat	Closed
Outdoor Fan(s)	Off
Reversing Valve	Energized
Check Valve A	Closed
Check Valve B	Closed
Check Valve C	Open
Check Valve D	Open
Check Valve E	Open
Check Valve F	Closed
Check Valve G	Closed
Check Valve H	Open

Table 16 — 50FCQ*24 – Cooling Mode

COMPONENT	STATUS/POSITION
Reversing Valve	Energized
Check Valve A	Closed
Check Valve B	Closed
Check Valve C	Open
Check Valve D	Open
Check Valve E	Open
Check Valve F	Closed
Check Valve G	Closed
Check Valve H	Open

Table 17 — 50FCQ*24 – Heating Mode

COMPONENT	STATUS/POSITION
Reversing Valve	De-energized
Check Valve A	Open
Check Valve B	Open
Check Valve C	Closed
Check Valve D	Closed
Check Valve E	Closed
Check Valve F	Open
Check Valve G	Open
Check Valve H	Closed

Table 18 — 50FCQ*24 – Defrost Mode

COMPONENT	STATUS/POSITION
Defrost Thermostat	Closed
Outdoor Fan(s)	Off
Reversing Valve	Energized
Check Valve A	Closed
Check Valve B	Closed
Check Valve C	Open
Check Valve D	Open
Check Valve E	Open
Check Valve F	Closed
Check Valve G	Closed
Check Valve H	Open

Table 19 — 50FCQ*28 – Cooling Mode

COMPONENT	STATUS/POSITION
Reversing Valve	Energized
Check Valve A	Closed
Check Valve B	Closed
Check Valve C	Open
Check Valve D	Open
Check Valve E	Open
Check Valve F	Closed
Check Valve G	Closed
Check Valve H	Open

Table 20 — 50FCQ*28 – Heating Mode

COMPONENT	STATUS/POSITION
Reversing Valve	De-energized
Check Valve A	Open
Check Valve B	Open
Check Valve C	Closed
Check Valve D	Closed
Check Valve E	Closed
Check Valve F	Open
Check Valve G	Open
Check Valve H	Closed

Table 21 — 50FCQ*28 – Defrost Mode

COMPONENT	STATUS/POSITION
Defrost Thermostat	Closed
Outdoor Fan(s)	Off
Reversing Valve	Energized
Check Valve A	Closed
Check Valve B	Closed
Check Valve C	Open
Check Valve D	Open
Check Valve E	Open
Check Valve F	Closed
Check Valve G	Closed
Check Valve H	Open

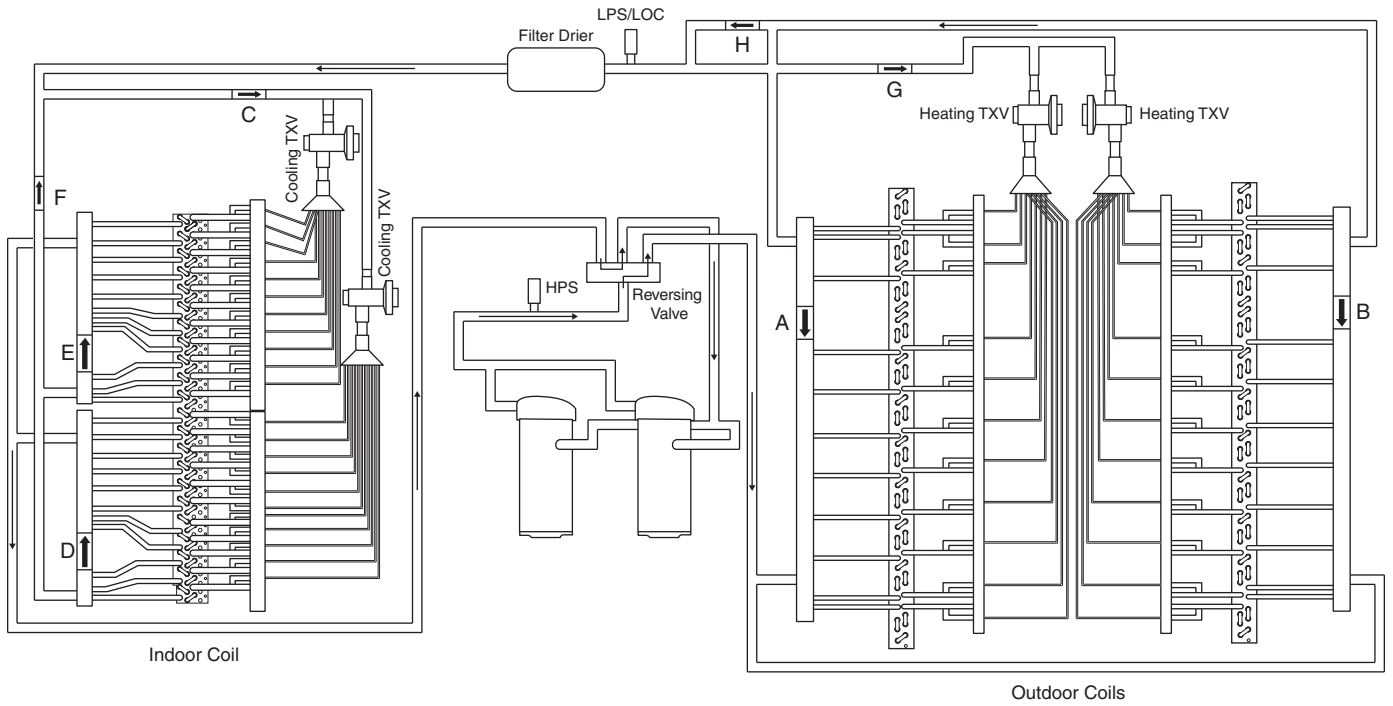

Fig. 71 — Piping Schematic — 50FCQ*17 Cooling Mode

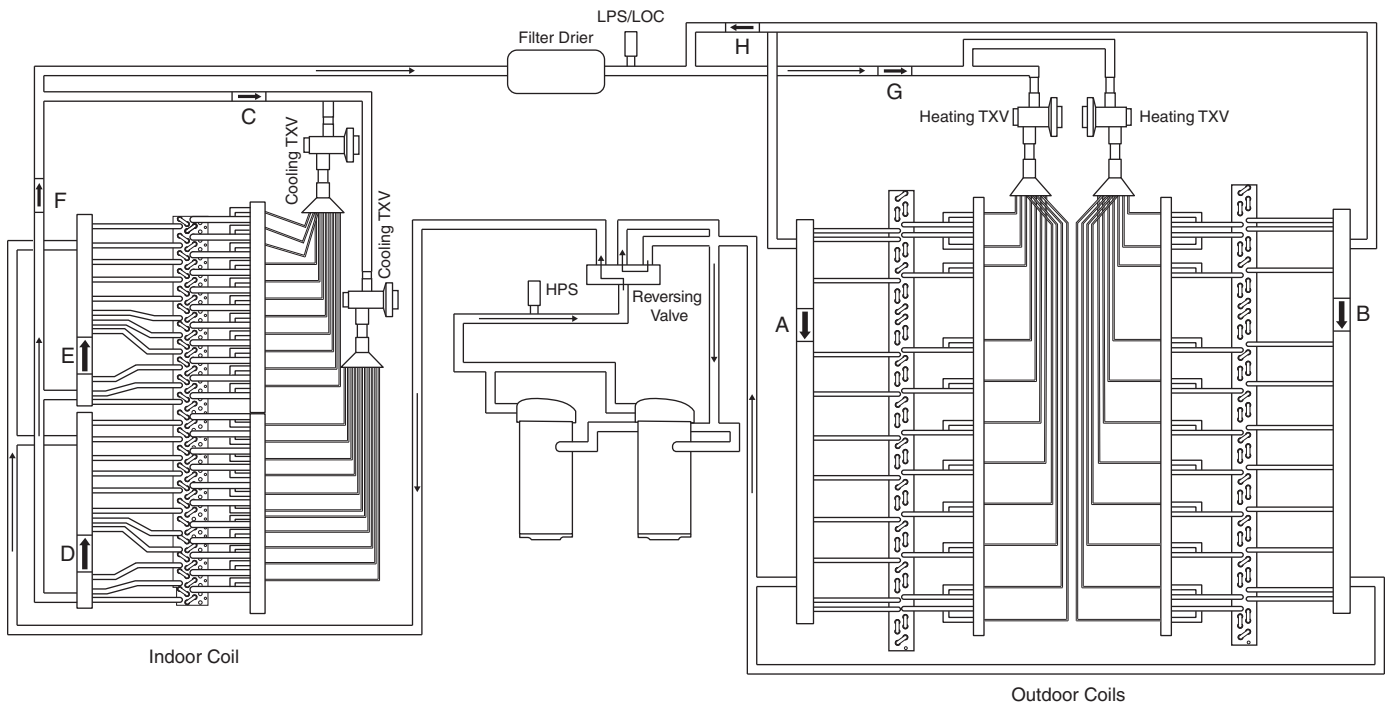

Fig. 72 — Piping Schematic — 50FCQ*17 Heating Mode

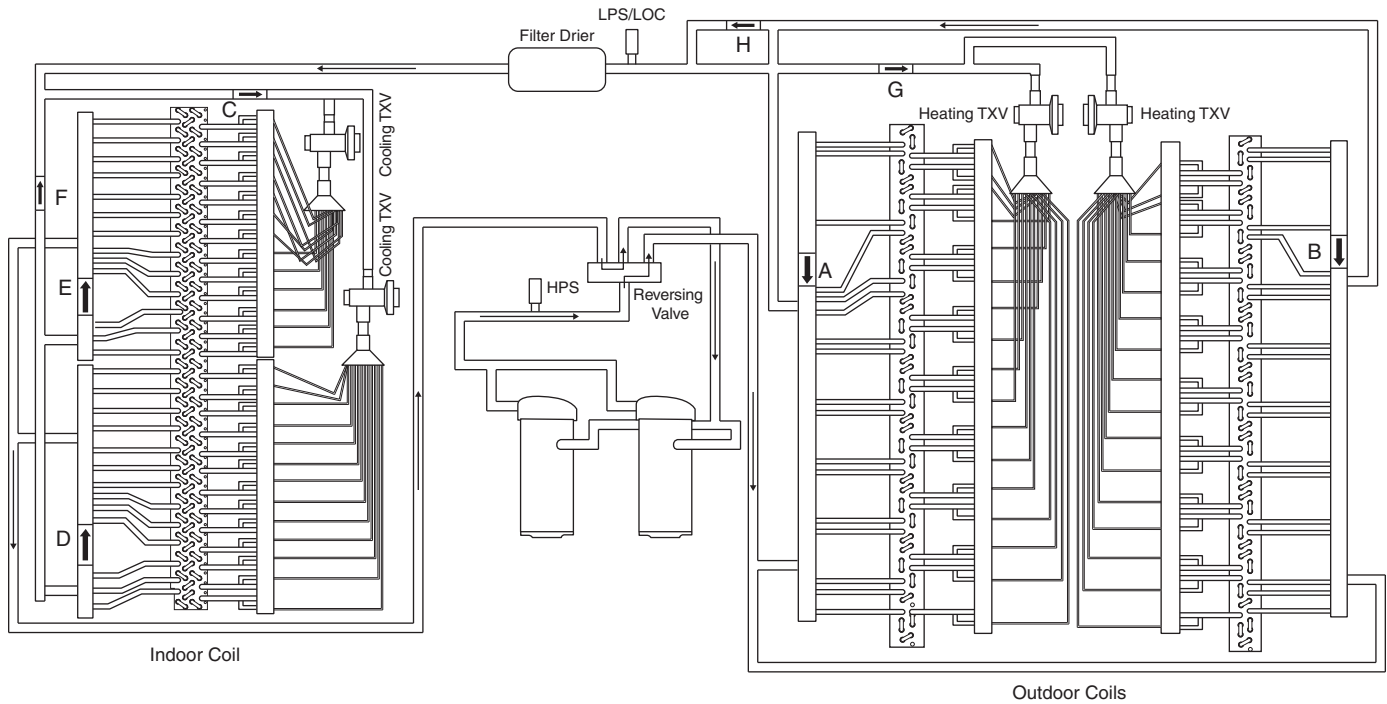

Fig. 73 — Piping Schematic — 50FCQ*24/28 Cooling Mode

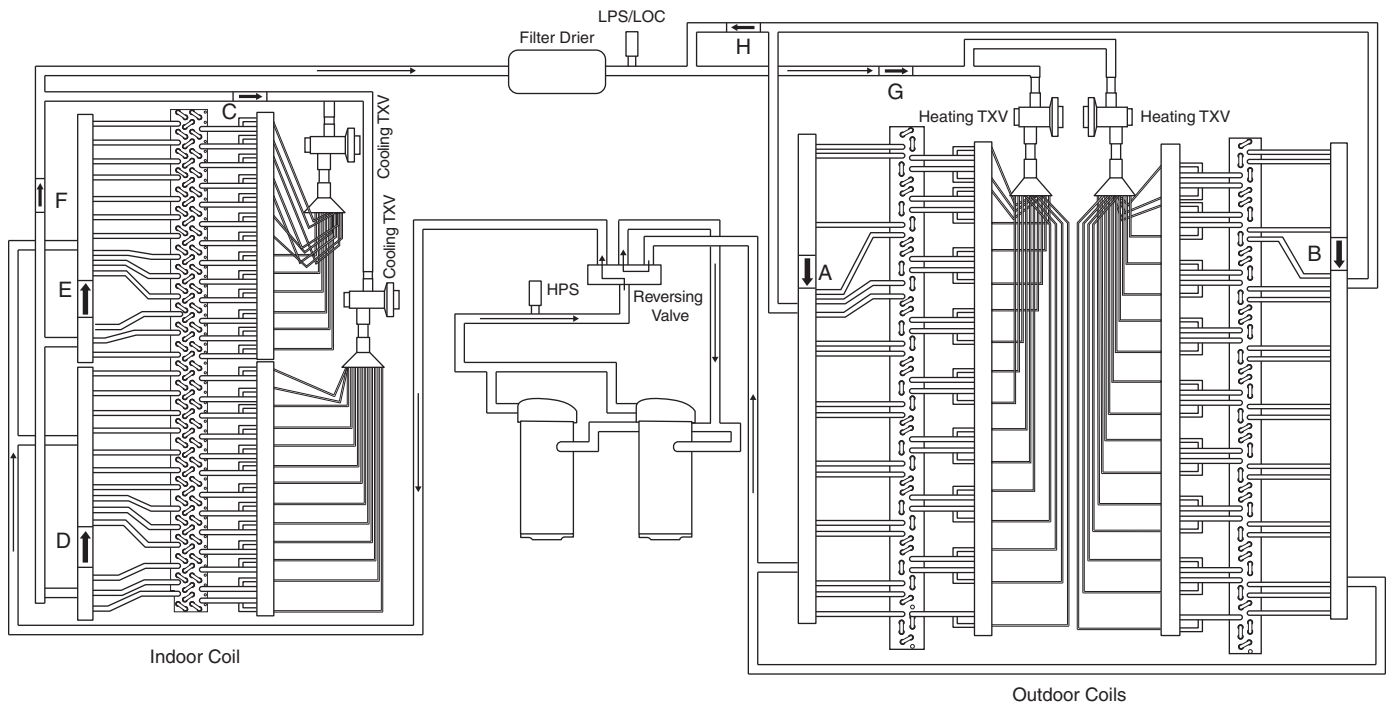

Fig. 74 — Piping Schematic — 50FCQ*24/28 Heating Mode

Pre-Start and Start-Up

This completes the mechanical installation of the unit. Refer to the unit's Service Manual for detailed Pre-Start and Start-Up instructions. Download the latest versions from HVAC Partners (www.hvacpartners.com).

**START-UP CHECKLIST — 50FCQ SINGLE PACKAGED ROOFTOP
HEAT PUMP UNITS**

(Remove and use for job file)

NOTE: To avoid injury to personnel and damage to equipment or property when completing the procedures listed in this start-up checklist, use good judgment, follow safe practices, and adhere to the safety considerations/information as outlined in preceding sections of this Installation Instruction document.

II. PRELIMINARY INFORMATION

MODEL NO _____
JOB NAME _____
SERIAL NO _____
ADDRESS _____
START-UP DATE _____
TECHNICIAN NAME _____
ADDITIONAL ACCESSORIES _____

II. PRE-START-UP

Verify that all packaging materials have been removed from unit (Y/N) _____
Verify installation of outdoor air hood (Y/N) _____
Verify that condensate connection is installed per instructions (Y/N) _____
Verify that all electrical connections and terminals are tight (Y/N) _____
Check that indoor-air filters are clean and in place (Y/N) _____
Check that outdoor air inlet screens are in place (Y/N) _____
Verify that unit is level (Y/N) _____
Verify that fan assembly is free of obstructions and rotor spins freely (Y/N) _____
Verify that scroll compressors are rotating in the correct direction (Y/N) _____
Verify installation of thermostat (Y/N) _____

III. START-UP

ELECTRICAL

Supply Voltage	L1-L2 _____	L2-L3 _____	L3-L1 _____
Compressor Amps 1	L1 _____	L2 _____	L3 _____
Compressor Amps 2	L1 _____	L2 _____	L3 _____
Supply Fan Amps	L1 _____	L2 _____	L3 _____
Outdoor Fan Amps	L1 _____	L2 _____	

TEMPERATURES

Outdoor-air Temperature _____ °F DB (Dry Bulb)
Return-air Temperature _____ °F DB _____ °F WB (Wet Bulb)
Cooling Supply Air Temperature _____ °F

PRESSURES

Refrigerant Suction _____ PSIG
Refrigerant Discharge _____ PSIG
Verify Refrigerant Charge using Charging Charts (Y/N) _____

GENERAL

Economizer minimum vent and changeover settings to job requirements (if equipped) (Y/N) _____
Verify smoke detector unit shutdown by utilizing magnet test (Y/N) _____

Manufacturer reserves the right to discontinue, or change at any time, specifications or designs without notice and without incurring obligations.

CUT ALONG DOTTED LINE

CUT ALONG DOTTED LINE