



Product Data

WeatherMaster® High Efficiency Single Packaged Heat Pump Rooftop

3 to 5 Nominal Tons

ecoblue™  technology



50GCQ 04, 05, 06
High Efficiency Single Packaged Heat Pump with
Puron® Refrigerant (R-410A) and Optional Electric Heat

The New Carrier WeatherMaster® heat pump rooftop units (RTU) with EcoBlue™ Technology were designed by customers for customers and integrate new technology to provide value added benefits never seen in this type of equipment before.

New major design features include:

- Patented, industry’s first efficient indoor fan system using Vane Axial Fan technology – with electronically commutated variable speed motor.
- Reliable two stage scroll compressor on all sizes.
- Upgraded unit control board with intuitive indoor fan adjustment.
- Reliable copper tube/aluminum fin condenser coil with 5/16 in. tubing to help reduce refrigerant charge verses prior designs.
- New outdoor fan system with rugged – lightweight high impact composite fan blade

WeatherMaster® 50GCQ units up to 5 tons are specifically designed to fit on Carrier roof curbs that were installed back to 1989, which makes replacement easy and eliminates the need for curb adapters or changing utility connections.

Two stage cooling capacity control delivers SEERs up to 17.0 and SEER2s up to 16.0, while heating HSPF is as

high as 8.9. All models are capable of either vertical or horizontal airflow.

The Carrier rooftop unit (RTU) was designed by customers for customers. With “no-strip” screw collars, handled access panels, and more, the unit is easy to install, easy to maintain, and easy to use. Your new 3 to 5 ton Carrier WeatherMaster rooftop unit (RTU) provides optimum comfort and control from a packaged rooftop.

Value-added features include:

- precisely sized Suction Line Accumulator to help ensure reliable operation at unit operation conditions
- Puron® refrigerant (R-410A)
- single point electrical connections
- optional fully integrated SystemVu™ controls
- RTU Open controller for BACnet™1, LonWorks®1, Modbus®1 and Johnson Controls N2
- optional fully insulated cabinet with optional foil faced insulation
- TXV refrigerant metering system
- scroll compressors with internal line-break overload protection
- easy access tool-less filter door. Filter track tilts out for filter removal and replacement. All filters are the same size in each unit.

Installation ease

All WeatherMaster units are field-convertible to horizontal airflow, which

1. Third-party trademarks and logos are the property of their respective owners.

makes it easy to adjust to unexpected job-site complications. Lighter units make for easy replacement. Simple, fast plug-in connections to the standard integrated unit control board (UCB). Clearly labeled connections points to reduce installation time. Also, a large control box provides room to work and room to mount Carrier accessory controls.

Easy to maintain

With the new EcoBlue Vane Axial fan system and direct drive ECM motor — there is no longer a need to adjust belts or pulleys as in past designs. This frees up maintenance and installation time.

Easy access handles by Carrier provide quick and easy access to all normally serviced components. Our “no-strip” screw system has superior holding power and guides screws into position while preventing the screw from stripping the unit’s metal.

Sloped, corrosion resistant composite drain pan sheds water; and won’t rust.

Easy to use

The newly re-designed Unit Control Board by Carrier puts all connections and troubleshooting points in one convenient place. Most low voltage connections are made to the same board and make it easy to access. Setting up the fan is simple by an intuitive switch and rotary dial arrangement. Carrier rooftops have high and low pressure switches, a filter drier, and 2-in. filters standard.

Table of contents

	Page
Features/Benefits	2
Model Number Nomenclature	4
Capacity Ratings	5
Physical Data	8
Options and Accessories	10
Base Unit Dimensions	15
Accessory Dimensions	18
Performance Data	19
Fan Data	30
Electrical Data	55
Typical Wiring Diagrams	77
Sequence of Operation	87
Application Data	89
Guide Specifications	90

Features/Benefits (cont)



EcoBlue™ Technology

Direct drive EcoBlue Technology indoor fan system uses Vane Axial fan design and direct drive electrically commutated motors.

This new Vane Axial design, compared to past belt drive systems, has 75% fewer moving parts, uses up to 40% less energy, and has no fan belts, blower bearings, or shaft.

Streamlined control and integration

Carrier controllers make connecting WeatherMaster® rooftops into existing

building automation systems easy. The units are compatible with conventional thermostat controls, SystemVu™ controls and Carrier RTU Open multi-protocol controller.

Operating efficiency and flexibility

The 50GCQ rooftops exceed ASHRAE (American Society of Heating, Refrigerating, and Air-Conditioning Engineers) 90.1-2016, IECC®1-2018 (International

Energy Conservation Code) minimum efficiency requirements.

Field convertible airflow

All WeatherMaster 3 to 5 ton units are field-convertible to horizontal airflow, which makes it easy to adjust to unexpected jobsite complications.

Comfort control

Carrier's Round Tube Plate Fin coils designs help maximize heat transfer and reliable operation.

1. Third-party trademarks and logos are the property of their respective owners.





50GCQ Model Number Nomenclature

Position:	1	2	3	4	5	6	7	8	9	10	11	12	13	14	15	16	17	18
Example:	5	0	G	C	Q	J	0	4	A	2	A	5	-	0	A	0	A	0

Unit/Series/Model

50GCQ = Packaged Rooftop Heat Pump
17 SEER and 16 SEER2 High Efficiency

Refrig. Systems Options

J = Two-Stage Cooling
T = Two-Stage Cooling (1 phase only)

Cooling Tons

04 = 3 tons
05 = 4 tons
06 = 5 tons

Sensor Options

A = None
B = Return Air (RA) Smoke Detector
C = Supply Air (SA) Smoke Detector
D = RA + SA Smoke Detector
E = CO₂ Sensor
F = RA Smoke Detector and CO₂ Sensor
G = SA Smoke Detector and CO₂ Sensor
H = RA + SA Smoke Detector and CO₂ Sensor
J = Condensate Overflow Switch (electromechanical controls only)
K = Condensate Overflow Switch and RA Smoke Detector
L = Condensate Overflow Switch and RA and SA Smoke Detectors
M = Condensate Overflow Switch and SA Smoke Detector

Indoor Fan Options

1 = Direct Drive — EcoBlue — Standard Static
2 = Direct Drive — EcoBlue — Medium Static
3 = Direct Drive — EcoBlue — High Static

Coil Options – (Outdoor - Indoor - Hail Guard)

A = Al/Cu — Al/Cu
B = Precoat Al/Cu — Al/Cu
C = E-coat Al/Cu — Al/Cu
D = E-coat Al/Cu — E-coat Al/Cu
E = Cu/Cu — Al/Cu
F = Cu/Cu — Cu/Cu
M = Al/Cu — Al/Cu — Louvered Hail Guard
N = Precoat Al/Cu — Al/Cu — Louvered Hail Guard
P = E-coat Al/Cu — Al/Cu — Louvered Hail Guard
Q = E-coat Al/Cu — E-coat Al/Cu — Louvered Hail Guard
R = Cu/Cu — Al/Cu — Louvered Hail Guard
S = Cu/Cu — Cu/Cu — Louvered Hail Guard

Voltage

1 = 575-3-60
3 = 208/230-1-60¹
5 = 208/230-3-60
6 = 460-3-60

¹ The following are not available as a factory-installed options for models with this voltage code: Coated Coils or Cu Fin Coils, Louvered Hail Guards, Economizer or Two-Position Damper, and Powered 115 Volt Convenience Outlet.

Packaging and Seismic Compliance

0 = Standard
1 = LTL

Electrical Options

A = None
C = Non-Fused Disconnect (NFD)
D = Thru-The-Base (TTB) Connections
F = Non-Fused Disconnect and TTB Connections
N = Phase Monitor Protection
Q = Phase Monitor Protection and NFD
R = Phase Monitor Protection and TTB Connections
T = Phase Monitor Protection and NFD and TTB Connections
1 = HSCCR (High Short Circuit Current Rating)

Service Options

0 = None
1 = Unpowered Convenience Outlet (CO)
2 = Powered Convenience Outlet
3 = Hinged Access Panels
4 = Hinged Access Panels and Unpowered CO
5 = Hinged Access Panels and Powered CO
6 = MERV-13 High Efficiency Filters
7 = Unpowered CO and MERV-13 High Efficiency (HE) Filters
8 = Powered CO and MERV-13 HE Filters
9 = Hinged Access Panels and MERV-13 HE Filters
A = Hinged Access Panels, Unpowered CO, and MERV-13 HE Filters
B = Hinged Access Panels, Powered CO, and MERV-13 HE Filters
C = Foil-Faced Insulation

Intake / Exhaust Options

A = None
B = Temperature Economizer with Barometric Relief
F = Enthalpy Economizer with Barometric Relief
U = Ultra Low Leak Temperature Economizer with Barometric Relief
W = Ultra Low Leak Enthalpy Economizer with Barometric Relief

Base Unit Controls

0 = Electromechanical Controls (allows for use of field-installed economizers)
2 = RTU Open Multi-Protocol Controller
3 = SystemVu™ Controls
8 = Electromechanical Controls with POL224 EconomizerONE (with Fault Detection and Diagnostic)

Design Revision

- = Factory Design Revision

50GCQT 1-Phase AHRI Ratings — Heating Mode^{a,b}

UNIT	VOLTAGE	HSPF 2	HIGH HEATING CAPACITY 2 (MBtuh)	HIGH HEAT COP 2	LOW HEATING CAPACITY 2 (MBtuh)	LOW HEAT COP 2
50GCQT04	3	7.3	33.2	3.6	18.0	2.30
50GCQT05	3	7.1	45.0	3.6	24.0	2.40
50GCQT06	3	7.5	51.0	3.7	34.0	2.60

NOTE(S):

- a. Rated and certified under AHRI Standard 210/240.
- b. Ratings are based on:
 Cooling Standard: 80°F (27°C) db, 67°F (19°C) wb indoor air temperature and 95°F (35°C) db outdoor air temperature.
 High Temperature Heating Ratings: 47°F (8°C) db, 43°F (6°C) wb outdoor air temperature and 70°F (21°C) entering indoor coil air.
 Low Temperature Heating Ratings: 17°F (-8°C) db, 15°F (-9°C) wb outdoor air temperature and 70°F (21°C) entering indoor coil air.

50GCQJ 3-Phase AHRI Ratings — Heating Mode^{a,b}

UNIT	VOLTAGE	HSPF	HIGH HEATING CAPACITY (MBtuh)	HIGH HEAT COP	LOW HEATING CAPACITY (MBtuh)	LOW HEAT COP	HSPF 2	HIGH HEATING CAPACITY 2 (MBtuh)	HIGH HEAT COP 2	LOW HEATING CAPACITY 2 (MBtuh)	LOW HEAT COP 2
50GCQJ04	1,5,6	8.8	33.2	3.8	18.0	2.40	7.3	33.2	3.6	18.0	2.30
50GCQJ05	1,5,6	8.7	45.0	3.7	24.4	2.40	7.1	45.0	3.6	24.0	2.40
50GCQJ06	1,5,6	8.9	52.5	3.8	32.4	2.70	7.5	51.0	3.7	34.0	2.60

NOTE(S):

- a. Rated and certified under AHRI Standard 210/240.
- b. Ratings are based on:
 Cooling Standard: 80°F (27°C) db, 67°F (19°C) wb indoor air temperature and 95°F (35°C) db outdoor air temperature.
 High Temperature Heating Ratings: 47°F (8°C) db, 43°F (6°C) wb outdoor air temperature and 70°F (21°C) entering indoor coil air.
 Low Temperature Heating Ratings: 17°F (-8°C) db, 15°F (-9°C) wb outdoor air temperature and 70°F (21°C) entering indoor coil air.

LEGEND

- AHRI — Air Conditioning, Heating and Refrigeration Institute
- ASHRAE — American Society of Heating, Refrigerating and Air Conditioning Engineers
- COP — Coefficient of Performance
- HSPF — Heating Seasonal Performance Factor



Capacity ratings (cont)



50GCQT 1-Phase AHRI Ratings — Cooling Mode^{a,b,c}

UNIT	VOLTAGE	COOLING STAGES	NOM CAPACITY (TONS)	NET COOLING CAPACITY 2 (MBtuh)	TOTAL POWER 2 (kW)	SEER 2	EER 2
50GCQT04	3	2	3	33.8	2.9	16.0	11.7
50GCQT05	3	2	4	47.0	3.9	16.0	12.0
50GCQT06	3	2	5	59.5	5.0	16.0	12.0

NOTE(S):

- Rated and certified under AHRI Standard 210/240.
- Ratings are based on:
Cooling Standard: 80°F (27°C) db, 67°F (19°C) wb indoor air temperature and 95°F (35°C) db outdoor air temperature.
High Temperature Heating Ratings: 47°F (8°C) db, 43°F (6°C) wb outdoor air temperature and 70°F (21°C) entering indoor coil air.
Low Temperature Heating Ratings: 17°F (-8°C) db, 15°F (-9°C) wb outdoor air temperature and 70°F (21°C) entering indoor coil air.
- All 50GCQ units comply with ASHRAE 90.1 Energy Standard for minimum SEER and EER requirements.

50GCQJ 3-Phase AHRI Ratings — Cooling Mode^{a,b,c}

UNIT	VOLTAGE	COOLING STAGES	NOM CAPACITY (TONS)	NET COOLING CAPACITY (MBtuh)	TOTAL POWER (kW)	SEER	EER	NET COOLING CAPACITY 2 (MBtuh)	TOTAL POWER 2 (kW)	SEER 2	EER 2
50GCQJ04	1,5,6	2	3	35.0	2.8	17.0	12.5	33.8	2.9	16.0	11.7
50GCQJ05	1,5,6	2	4	48.0	3.8	17.0	12.5	47.0	3.9	16.0	12.0
50GCQJ06	1,5,6	2	5	60.0	4.9	17.0	12.3	59.5	5.0	16.0	12.0

NOTE(S):

- Rated and certified under AHRI Standard 210/240.
- Ratings are based on:
Cooling Standard: 80°F (27°C) db, 67°F (19°C) wb indoor air temperature and 95°F (35°C) db outdoor air temperature.
High Temperature Heating Ratings: 47°F (8°C) db, 43°F (6°C) wb outdoor air temperature and 70°F (21°C) entering indoor coil air.
Low Temperature Heating Ratings: 17°F (-8°C) db, 15°F (-9°C) wb outdoor air temperature and 70°F (21°C) entering indoor coil air.
- All 50GCQ units comply with ASHRAE 90.1 Energy Standard for minimum SEER and EER requirements.

LEGEND

- AHRI** — Air Conditioning, Heating and Refrigeration Institute
ASHRAE — American Society of Heating, Refrigerating and Air Conditioning Engineers
EER — Energy Efficiency Ratio
HSPF — Heating Seasonal Performance Factor
SEER — Seasonal Energy Efficiency Ratio



Sound Ratings Table^{a,b,c}

UNIT	COOLING STAGES	OUTDOOR SOUND (dB) AT 60 Hz								
		A-Weighted	63	125	250	500	1000	2000	4000	8000
50GCQ*04	2	75.4	81.8	81.8	77.0	72.6	69.9	64.6	59.3	55.6
50GCQ*05	2	79.0	85.6	84.7	80.5	76.0	72.4	68.0	62.8	59.3
50GCQ*06	2	79.0	85.6	84.7	80.5	76.0	72.4	68.0	62.8	59.3

NOTE(S):

- Outdoor sound data is measured in accordance with AHRI.
- Measurements are expressed in terms of sound power. Do not compare these values to sound pressure values because sound pressure depends on specific environmental factors which normally do not match individual applications. Sound power values are independent of the environment and therefore more accurate.
- A-weighted sound ratings filter out very high and very low frequencies, to better approximate the response of "average" human ear. A-weighted measurements for Carrier units are taken in accordance with AHRI.

LEGEND

dB — Decibel

Minimum - Maximum Airflow Ratings (cfm) — Cooling Units and Accessory Electric Heat

UNIT	COOLING				ELECTRIC HEAT ^a	
	Minimum Airflow cfm	Minimum 2-Speed Airflow (Low Speed)	Minimum 2-Speed Airflow (High Speed)	Maximum Airflow cfm	Minimum Airflow cfm	Maximum Airflow cfm
50GCQ*04	900	675	900	1500	900	1500
50GCQ*05	1200	900	1200	2000	1200	2000
50GCQ*06	1500	1125	1500	2500	1500	2500

NOTE(S):

- Electric heat modules are available as field-installed accessories for 50GCQ units.

50GCQJ 3 to 5 Ton Physical Data Three Phase Units

50GCQ UNIT	50GCQJ04	50GCQJ05	50GCQJ06
NOMINAL TONS	3	4	5
BASE UNIT OPERATING WT (lb)^a	475	590	596
REFRIGERATION SYSTEM			
No. Circuits / No. Compressors / Type	1 / 1 / 2-Stage Scroll	1 / 1 / 2-Stage Scroll	1 / 1 / 2-Stage Scroll
Puron® (R-410A) Charge (lb-oz)	10-3.2	12-4.8	14-3.2
Metering Device	TXV	TXV	TXV
High-Pressure Trip / Reset (psig)	630 / 505	630 / 505	630 / 505
Low-Pressure Trip / Reset (psig)	54 / 117	54 / 117	54 / 117
EVAPORATOR COIL (Indoor)			
Material (Tube/Fin)	Cu/Al	Cu/Al	Cu/Al
Coil Type	3/8 in. RTPF	3/8 in. RTPF	3/8 in. RTPF
Rows / FPI	3 / 15	3 / 15	4 / 15
Total Face Area (ft²)	5.5	7.3	7.3
Condensate Drain Connection Size	3/4 in.	3/4 in.	3/4 in.
CONDENSER COIL (Outdoor)			
Material	Cu/Al	Cu/Al	Cu/Al
Coil Type	5/16 in. RTPF	5/16 in. RTPF	5/16 in. RTPF
Rows / FPI	2 / 18	2 / 18	2 / 18
Total Face Area (ft²)	14.6	18.8	18.8
EVAPORATOR FAN AND MOTOR (Indoor)			
Standard Static 3 Phase			
Motor Qty / Drive Type	1 / Direct	1 / Direct	1 / Direct
Max Cont bhp	0.44	0.72	1.06
Rpm Range	189-1890	190-1900	215-2150
Fan Qty / Type	1 / Vane Axial	1 / Vane Axial	1 / Vane Axial
Fan Diameter (in.)	16.6	16.6	16.6
Medium Static 3 Phase			
Motor Qty / Drive Type	1 / Direct	1 / Direct	1 / Direct
Max Cont bhp	0.71	1.06	1.44
Rpm Range	219-2190	217-2170	239-2390
Fan Qty / Type	1 / Vane Axial	1 / Vane Axial	1 / Vane Axial
Fan Diameter (in.)	16.6	16.6	16.6
High Static 3 Phase			
Motor Qty / Drive Type	1 / Direct	1 / Direct	1 / Direct
Max Cont bhp	1.07	1.96	2.43
Rpm Range	249-2490	266-2660	284-2836
Fan Qty / Type	1 / Vane Axial	1 / Vane Axial	1 / Vane Axial
Fan Diameter (in.)	16.6	16.6	16.6
CONDENSER FAN AND MOTOR (Outdoor)			
Qty / Motor Drive Type	1 / Direct	1 / Direct	1 / Direct
Motor hp / rpm	1/5 / 825/675	1/4 / 1100/900	1/4 / 1100/900
Fan Diameter (in.)	23	23	23
FILTERS			
RA Filter Qty / Size (in.)	2 / 16 x 25 x 2	4 / 16 x 16 x 2	4 / 16 x 16 x 2
OA Inlet Screen Qty / Size (in.)	1 / 20 x 24 x 1	1 / 20 x 24 x 1	1 / 20 x 24 x 1

NOTE(S):

a. Base unit operating weight does not include weight of options.

LEGEND

bhp — Break Horsepower
FPI — Fins Per Inch
OA — Outdoor Air
RA — Return Air

50GCQT 3 to 5 Ton Physical Data Single Phase Units

50GCQ UNIT	50GCQT04	50GCQT05	50GCQT06
NOMINAL TONS	3	4	5
BASE UNIT OPERATING WT (lb)^a	475	590	596
REFRIGERATION SYSTEM			
No. Circuits / No. Compressors / Type	1 / 1 / 2-Stage Scroll	1 / 1 / 2-Stage Scroll	1 / 1 / 2-Stage Scroll
Puron® (R-410A) Charge (lb-oz)	10-3.2	12-4.8	14-3.2
Metering Device	TXV	TXV	TXV
High-Pressure Trip / Reset (psig)	630 / 505	630 / 505	630 / 505
Low-Pressure Trip / Reset (psig)	54 / 117	54 / 117	54 / 117
EVAPORATOR COIL (Indoor)			
Material (Tube/Fin)	Cu/Al	Cu/Al	Cu/Al
Coil Type	3/8 in. RTPF	3/8 in. RTPF	3/8 in. RTPF
Rows / FPI	3 / 15	3 / 15	4 / 15
Total Face Area (ft²)	5.5	7.3	7.3
Condensate Drain Connection Size	3/4 in.	3/4 in.	3/4 in.
CONDENSER COIL (Outdoor)			
Material	Cu/Al	Cu/Al	Cu/Al
Coil Type	5/16 in. RTPF	5/16 in. RTPF	5/16 in. RTPF
Rows / FPI	2 / 18	2 / 18	2 / 18
Total Face Area (ft²)	14.6	18.8	18.8
EVAPORATOR FAN AND MOTOR (Indoor)			
Standard Static 1 Phase			
Motor Qty / Drive Type	1 / Direct	1 / Direct	1 / Direct
Max Cont bhp	0.44	0.72	1.06
Rpm Range	189-1890	190-1900	215-2150
Fan Qty / Type	1 / Vane Axial	1 / Vane Axial	1 / Vane Axial
Fan Diameter (in.)	16.6	16.6	16.6
Medium Static 1 Phase			
Motor Qty / Drive Type	1 / Direct	1 / Direct	1 / Direct
Max Cont bhp	0.71	1.06	1.44
Rpm Range	219-2190	217-2170	239-2390
Fan Qty / Type	1 / Vane Axial	1 / Vane Axial	1 / Vane Axial
Fan Diameter (in.)	16.6	16.6	16.6
High Static 1 Phase			
Motor Qty / Drive Type	1 / Direct	1 / Direct	—
Max Cont bhp	1.07	1.53	—
Rpm Range	249-2490	246-2460	—
Fan Qty / Type	1 / Vane Axial	1 / Vane Axial	—
Fan Diameter (in.)	16.6	16.6	—
CONDENSER FAN AND MOTOR (Outdoor)			
Qty / Motor Drive Type	1 / Direct	1 / Direct	1 / Direct
Motor hp / rpm	1/5 / 825/675	1/4 / 1100/900	1/4 / 1100/900
Fan Diameter (in.)	23	23	23
FILTERS			
RA Filter Qty / Size (in.)	2 / 16 x 25 x 2	4 / 16 x 16 x 2	4 / 16 x 16 x 2
OA Inlet Screen Qty / Size (in.)	1 / 20 x 24 x 1	1 / 20 x 24 x 1	1 / 20 x 24 x 1

NOTE(S):

a. Base unit operating weight does not include weight of options.

LEGEND

bhp — Break Horsepower
FPI — Fins Per Inch
OA — Outdoor Air
RA — Return Air

Options and accessories



ITEM	FACTORY-INSTALLED OPTION	FIELD-INSTALLED ACCESSORY
ELECTRIC HEAT		
Electric Resistance Heaters		X
Single Point Kits		X
CABINET		
Thru-the-Base Electrical Connections	X	X
Hinged Access Panels	X	
COIL OPTIONS		
Cu/Cu Indoor and/or Outdoor Coils ^a	X	
Pre-Coated Outdoor Coils ^a	X	
Premium, E-coated Outdoor Coils ^a	X	
CONDENSER PROTECTION		
Condenser Coil Hail Guard (louvered design) ^a	X	X
CONTROLS		
Thermostats, Temperature Sensors, and Subbases		X
SystemVu™ DDC Communicating Controller	X	
RTU Open Multi-Protocol Controller	X	
Smoke Detector (supply and/or return air)	X	X
Horn Strobe Annunciator ^b		X
Time Guard II Compressor Delay Control Circuit		X
Phase Monitor ^a	X	X
Condensate Overflow Switch	X	X
FILTERS		
MERV-13 Filters	X	X
ECONOMIZERS AND OUTDOOR AIR DAMPERS		
EconomizerONE for Electromechanical Controls, complies with FDD (Standard and Ultra Low Leak damper models) ^{a,c}	X	X
Wi-Fi Stick for EconomizerONE (optional)		X
EconoMi\$er® 2 for DDC Controls (Standard and Ultra Low Leak air damper models) ^{a,d}	X	X
Motorized Two-Position Outdoor-Air Damper ^a	X	X
Manual Outdoor-Air Damper (25% and 50%)		X
Barometric Relief ^e	X	X
Power Exhaust — Prop Design		X

ITEM	FACTORY-INSTALLED OPTION	FIELD-INSTALLED ACCESSORY
ECONOMIZER SENSORS AND IAQ DEVICES		
Single Dry Bulb Temperature Sensors ^f	X	X
Differential Dry Bulb Temperature Sensors ^f		X
Single Enthalpy Sensors ^f	X	X
Differential Enthalpy Sensors ^f		X
CO ₂ Sensor (wall, duct, or unit mounted) ^f	X	X
INDOOR MOTOR AND DRIVE		
Multiple Motor and Drive Packages	X	
LOW AMBIENT CONTROL		
Winter Start Kits ^g		X
Low Ambient Controller to -20°F (-29°C) ^g	X	X
POWER OPTIONS		
Convenience Outlet (powered) ^a	X	
Convenience Outlet (unpowered)	X	
HACR Circuit Breaker ^h	X	
Non-Fused Disconnect ⁱ	X	
ROOF CURBS		
Roof Curb 14 in. (356 mm)		X
Roof Curb 24 in. (610 mm)		X

NOTE(S):

- a. Not available on single phase (-3 voltage code) models. Use field-installed accessory where available.
- b. Requires a field-supplied 24V transformer for each application. See price pages for details.
- c. FDD (Fault Detection and Diagnostic) capability per California Title 24 section 120.2.
- d. Models with SystemVu and RTU Open DDC controls comply with California Title 24 Fault Detection and Diagnostic (FDD).
- e. Included with economizer.
- f. Sensors used to optimize economizer performance.
- g. See application data for assistance.
- h. HACR circuit breaker cannot be used on 04-06 sizes when unit FLA electrical rating exceeds:
208/230/1/60 and 208/230/3/60 = 100 amps (FLA)
460/3/60 = 90 amps (FLA)
Carrier RTUBuilder automatically selects the amps limitations.
- i. Non-fused disconnect switch cannot be used when unit electrical rating exceeds:
208-230/1/60 and 208-230/3/60 = 80 amps (FLA).
480/3/60 and 575/3/60 = 80 amps (FLA).
Carrier RTUBuilder automatically selects the amp limitations.

Factory-installed options

Economizer (dry-bulb or enthalpy)

Economizers save money. They bring in fresh, outside air for ventilation; and provide cool outside air to cool your building. This is the preferred method of low-ambient cooling. When coupled to CO₂ sensors, economizers can provide even more savings by coupling the ventilation air to only that amount required.

Economizers are available, installed and tested by the factory, with either enthalpy or dry-bulb temperature inputs. Additional sensors are available as accessories to optimize the economizers. Economizers include a powered exhaust system to help equalize building pressures.

Economizers include gravity controlled barometric relief that helps equalize building pressure and ambient air pressures. This can be a cost effective solution to prevent building pressurization. Economizers are available in Ultra Low Leak and standard low leak versions. Economizers can be factory-installed or easily field-installed.

Unit mounted CO₂ sensor

The CO₂ sensor works with the economizer to intake only the correct amount of outside air for ventilation. As occupants fill your building, the CO₂ sensor detects their presence through increasing CO₂ levels, and opens the economizer appropriately. When the occupants leave, the CO₂ levels decrease, and the sensor appropriately closes the economizer. This intelligent control of the ventilation air, called demand controlled ventilation (DCV) reduces the overall load on the rooftop, saving money. Also available as a field-installed accessory.

Smoke detector (supply and/or return air)

Trust the experts. Smoke detectors make your application safer and your job easier. Carrier smoke detectors immediately shut down the rooftop unit when smoke is detected. They are available, installed by the factory, for supply air, return air, or both.

Thru-the-base connection

Thru-the-base connections, available as a factory option, are necessary to ensure proper connection and seal when routing wire and piping through the rooftop's basepan and curb. These couplings eliminate roof penetration and should be considered for main power lines, as well as control power.

Hinged access panels

Allows access to unit's major components with specifically designed hinged access panels. Panels are filter, control box access indoor fan motor access.

Cu/Cu (indoor) coils

Copper fins and copper tubes are mechanically bonded to copper tubes and copper tube sheets. A polymer strip prevents coil assembly from contacting the sheet metal coil pan to minimize potential for galvanic corrosion between coil and pan.

E-coated (outdoor and indoor) coils

A flexible epoxy polymer coating uniformly applied to all coil surface areas without material bridging between fins. Coating process shall ensure complete coil encapsulation of tubes, fins and headers.

Pre-coated outdoor coils

A durable epoxy-phenolic coating to provide protection in mildly corrosive coastal environments. The coating minimizes galvanic action between dissimilar metals. Coating is applied to the aluminum fin stock prior to the fin stamping process to create an inert barrier between the aluminum fin and copper tube.

Condenser coil hail guard

Sleek, louvered panels protect the condenser coil from hail damage, foreign objects, and incidental contact.

Single enthalpy sensor

Prevents the wheel from rotating if the outside air conditions are acceptable for free cooling. Both exhaust and supply blowers will remain on.

Convenience outlet (powered or un-powered)

Reduce service and/or installation costs by including a convenience outlet in your specification. Carrier will install this service feature at our factory. Provides a convenient, 15 amp, 115v GFCI receptacle with "Wet in Use" cover. The "powered" option allows the installer to power the outlet from the line side of the disconnect or load side as required by code. The "unpowered" option is to be powered from a separate 115/120v power source.

The unpowered convenience outlet is available as a 15 amp factory-installed option or a 20 amp field-installed accessory.

HACR breaker

These manual reset devices provide overload and short circuit protection for the unit. Factory wired and mounted with the units with access cover to provide protection from the environment.

Non-fused disconnect

This OSHA-compliant, factory-installed, safety switch allows a service technician to locally secure power to the rooftop. When selecting a factory-installed non-fused disconnect, note they are sized for the unit as ordered from the factory. The sizing of these do not accommodate field-installed items such as power exhaust devices, etc. If field installing electric heat with factory-installed non-fused disconnect switch, a single point kit may or may not be required.

SystemVu™ controller

Carrier's SystemVu controller is an optional factory-installed and tested controller.

This controller takes on a whole new approach to provide an intuitive, intelligent controller that not only monitors and controls the unit, but also provides linkage to multiple building automation systems.

Each SystemVu controller makes it easy to set up, service, troubleshoot, gain historical data, generate reports and provide comfort only Carrier is noted for.

Key features include:

- Easy to read back lit four line text screen for superior visibility.
- Quick operational condition LEDs of: Run, Alert, and Fault.
- Simple navigation with large keypad buttons of: Navigation arrows, Test, Back, Enter and Menu.
- Capable of being controlled with a conventional thermostat, space sensor or build automation system.

- Service capabilities include:
 - Auto run test
 - Manual run test
 - Component run hours and starts
 - Commissioning reports
 - Data logging
- Full range of diagnosis:
 - Read refrigerant pressures without the need of gauges
 - Sensor faults
 - Compressor reverse rotation
 - Economizer diagnostics that meet California Title 24 requirements
- Quick data transfer via USB port:
 - Unit configuration uploading/downloading
 - Data logging
 - Software upgrades
- Built in capacity for:
 - i-Vu® open systems
 - BACnet systems
 - CCN systems
- Configuration and alarm point capability:
 - Contain over 100 alarm codes
 - Contain over 260 status, troubleshooting, diagnostic and maintenance points
 - Contain over 270 control configuration set points

RTU Open, multi-protocol controller

Connect the rooftop to an existing BAS (building automation system) without needing complicated translators or adapter modules using the RTU Open controller. The RTU Open controller speaks the 4 most common building automation system languages (BACnet, Modbus, Johnson Controls N2, and LonWorks). Use this controller when you have an existing BAS. Besides the 4 protocols, it also communicates with a Carrier Open system (i-Vu and VVT®).

Condensate overflow switch

This sensor and related controller monitors the condensate level in the drain pan and shuts down compression operation when overflow conditions occur. It includes:

- Indicator light – solid red (more than 10 seconds on water contact – compressors disabled), blinking red (sensor disconnected)
- 10 second delay to break – eliminates nuisance trips from splashing or waves in pan (sensor needs 10 seconds of constant water contact before tripping)
- Disables the compressor(s) operation when condensate plug is detected, but still allows fans to run for economizer.

MERV-13 return air filters

This factory option upgrades the return air filters from standard unit filters to high efficiency MERV-13 filters. Non-woven MERV-13 filter media with high strength, moisture-resistant frame. Filter media is securely fastened inside the filter frame on all four sides.

Low ambient controller

The low ambient controller is a head pressure controller kit that is designed to maintain the unit's condenser head pressure during periods of low ambient cooling operation. This device should be used as an alternative to economizer free cooling when economizer usage is either not appropriate or desired. The low ambient controller will either cycle the outdoor fan motors or operate them at reduced speed to

maintain the unit operation, depending on the model. This controller allows cooling operation down to -20°F (-29°C) ambient conditions.

Field-installed accessories

Electric heaters and single point kits

Carrier offers a full-line of field-installed accessory heaters. The heaters are very easy to use, install and are all pre-engineered and certified. Electric heaters are available as either factory-installed options or field-installed accessories.

Filter maintenance indicator

When the optional factory-installed filter maintenance indicator is used, a factory-installed differential pressure switch measures pressure drop across the outside air filter, and activates a field-supplied dry contact indicator when the pressure differential exceeds the adjustable switch set point.

Condenser coil hail guard

Sleek, louvered panels protect the condenser coil from hail damage, foreign objects, and incidental contact. This can be purchased as a factory-installed option or as a field-installed accessory.

Differential enthalpy sensor

The differential enthalpy sensor is comprised of an outdoor and return air enthalpy sensors to provide differential enthalpy control. The sensor allows the unit to determine if outside air is suitable for free cooling.

Wall or duct mounted CO₂ sensor

The IAQ sensor shall be available in duct or wall mount. The sensor provides demand ventilation indoor air quality (IAQ) control.

Winter start kit

The winter start kit by Carrier extends the low ambient limit of your rooftop to 25°F (-4°C). The kit bypasses the low pressure switch, preventing nuisance tripping of the low pressure switch. Other low ambient precautions may still be prudent.

MERV-13 return air filters

This field-installed accessory upgrades the return air filters from standard unit filters to high efficiency MERV-13 filters. Non-woven MERV-13 filter media with high strength, moisture-resistant frame. Filter media is securely fastened inside the filter frame on all four sides.

Low ambient controller

The low ambient controller is a head pressure controller kit that is designed to maintain the unit's condenser head pressure during periods of low ambient cooling operation. This device should be used as an alternative to economizer free cooling not when economizer usage is either not appropriate or desired. The low ambient controller will either cycle the outdoor-fan motors or operate them at reduced speed to maintain the unit operation, depending on the model. This controller allows cooling operation down to -20°F (-29°C) ambient conditions.

Roof curb (14 in./356 mm or 24 in./610 mm)

Full perimeter roof curb with exhaust capability provides separate air streams for energy recovery from the exhaust air without supply air contamination.

Fan/filter status switch

Monitors static pressure across supply and exhaust filters and provides indication when filters become clogged.

Manual OA damper

Manual outdoor air dampers are an economical way to bring in ventilation air. The dampers are available in 25% and 50% versions.

Motorized two-position damper

The Carrier two-position, motorized outdoor air damper admits up to 100% outside air. Using reliable, gear-driven technology, the 2-position damper opens to allow ventilation air and closes when the rooftop stops, stopping unwanted infiltration.

Time Guard II control circuit

This accessory protects your compressor by preventing short-cycling in the event of some other failure, prevents the compressor from restarting for 30 seconds after stopping. Not required with SystemVu™ controller, RTU Open controller, or authorized commercial thermostats.

Power exhaust

Superior internal building pressure control. This field-installed accessory may eliminate the need for costly, external pressure control fans.

Phase monitor protection

The Phase Monitor Control will monitor the sequence of three phase electrical system to provide a phase reversal

protection; and monitor the three phase voltage inputs to provide a phase loss protection for the three phase device. It will work on either a Delta or Wye power connection.

Wi-Fi Stick for EconomizerONE (optional)

The accessory Wi-Fi/WLAN stick can be connected to the EconomizerONE POL224 economizer controller via the USB host interface. The Wi-Fi stick enables a wireless connection to be made between a smartphone and the economizer controller via the Climatix™¹ mobile application for commissioning, troubleshooting, and maintenance operations. The Wi-Fi stick is required to utilize the mobile application.

Climatix™ mobile application

The Climatix™ mobile application offers a best-in-class user interface and a simple step-by-step commissioning workflow using a mobile device. The user interface walks users through the setup of the controller and allows users to view the operating mode and parameters. Users can adjust setpoints, initiate damper tests, and save the final configuration as a favorite to expedite setup in the future.

The application is available on Android™¹ and Apple iOS®¹ platforms. The Wi-Fi stick for the EconomizerONE is required to join the Siemens-WiFi-Stick network and setup the controller on a smartphone.

1. Third-party trademarks and logos are the property of their respective owners.

Options and Accessory Weights^a

OPTION / ACCESSORY NAME	50GCQ UNIT WEIGHT					
	04		05		06	
	lb	kg	lb	kg	lb	kg
Power Exhaust — Vertical	51	23	51	23	51	23
Power Exhaust — Horizontal	39	18	39	18	39	18
EconomizerONE and EconoMiSer® 2	51	23	51	23	51	23
Two-Position Damper	39	18	39	18	39	18
Manual Damper	12	5	12	5	12	5
Hail Guard (louvered)	13	6	13	6	17	8
Cu/Cu Condenser Coil	37	17	74	34	90	41
Cu/Cu Condenser and Evaporator Coils	75	34	144	66	160	73
Roof Curb (14 in. curb)	95	43	95	43	95	43
Roof Curb (24 in. curb)	150	68	150	68	150	68
CO ₂ Sensor	2	1	2	1	2	1
Optional Indoor Motor/Drive	10	5	10	5	10	5
Low Ambient Controller	9	4	9	4	9	4
Winter Start Kit	5	2	5	2	5	2
Return Air Smoke Detector	7	3	7	3	7	3
Supply Air Smoke Detector	7	3	7	3	7	3
Fan Filter Switch	2	1	2	1	2	1
Non-Fused Disconnect	15	7	15	7	15	7
Powered Convenience Outlet	36	16	36	16	36	16
Unpowered Convenience Outlet	4	2	4	2	4	2
Enthalpy Sensor	2	1	2	1	2	1
Differential Enthalpy Sensor	3	1	3	1	3	1

NOTE(S):

a. Where multiple variations are available, the heaviest combination is listed.

50GCQ*04-06 Base Unit Dimensions

- NOTES:
1. DIMENSIONS ARE IN INCHES, DIMENSIONS IN [] ARE IN MILLIMETERS.
 2. CENTER OF GRAVITY
 3. DIRECTION OF AIR FLOW
 4. ALL VIEW DRAWN USING 3RD ANGLE

UNIT	J	K
50GCQ*04	33 3/8 [847]	18 5/8 [472]
50GCQ*05	41 3/8 [1051]	18 5/8 [472]
50GCQ*06	41 3/8 [1051]	18 5/8 [472]



THIS DOCUMENT IS THE PROPERTY OF UTC CLIMATE CONTROLS & SECURITY AND IS DELIVERED UPON THE EXPRESS CONDITION THAT THE CONTENTS WILL NOT BE DISCLOSED OR USED WITHOUT WRITTEN CONSENT.

SUBMISSION OF THESE DRAWINGS OR DOCUMENTS DOES NOT CONSTITUTE PART PERFORMANCE OR ACCEPTANCE OF CONTRACT.

CONNECTION SIZES	
A	1 3/8" [35] DIA FIELD POWER SUPPLY HOLE
B	2" [51] DIA POWER SUPPLY KNOCKOUT
C	1 3/4" [44] DIA GAUGE ACCESS PLUG
D	7/8" [22] DIA FIELD CONTROL WIRING HOLE
E	3/4"-14 NPT CONDENSATE DRAIN
G	2 1/2" [64] DIA POWER SUPPLY KNOCK-OUT

THRU-THE-BASE CHART THESE HOLES REQUIRED FOR USE CRBTMPWRO08A00, 009A00			
	THREADED CONDUIT SIZE	WIRE USE	REQ'D HOLE SIZES (MAX.)
W	1/2"	115V	7/8" [22.2]
X	1/2"	24V	7/8" [22.2]
Y *	3/4"	POWER	1 1/8" [28.6]
Z **	(009A00) 1/2" FPT	GAS	1 1/8" [28.6]

FOR "THRU-THE-BASEPAN" FACTORY OPTION, FITTINGS FOR ONLY X, Y, & Z ARE PROVIDED

* SELECT EITHER 3/4" OR 1/2" FOR POWER, DEPENDING ON WIRE SIZE

** (008A00) PROVIDES 3/4" FPT THRU CURB FLANGE & FITTING.

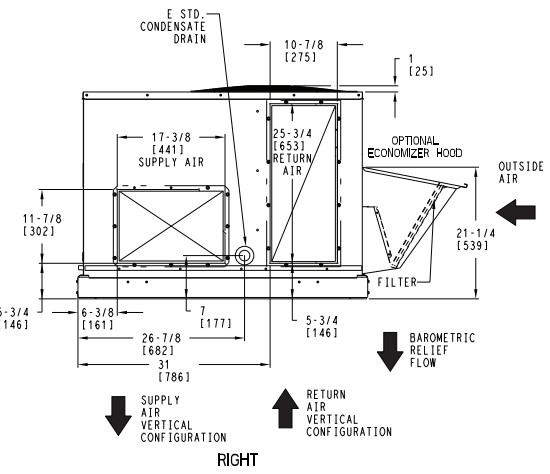
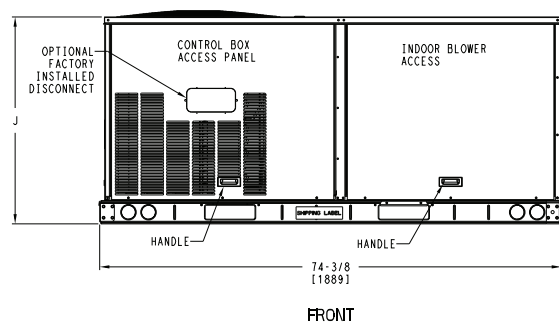
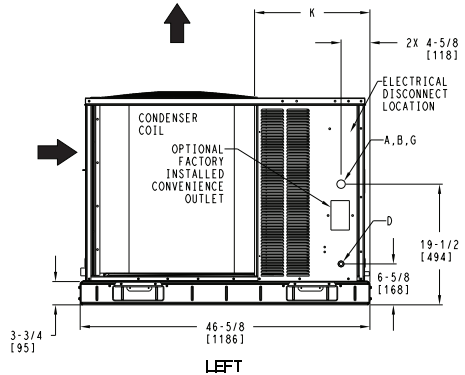
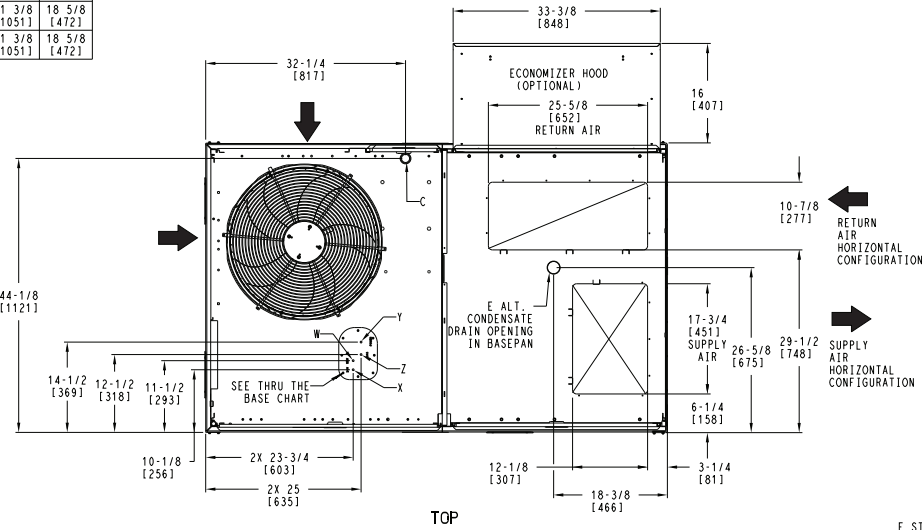

ITC CLASSIFICATION	SHEET	DATE	SUPERCEDES	50GCQ 04-06 SINGLE PACKAGE HEAT PUMP	48TC003351	REV
U.S. ECCN:NSR	1 OF 3	01/09/20	08/15/19			A



50GCQ*04-06 Base Unit Dimensions (cont)

UNIT	STD. UNIT WEIGHT *		CORNER WEIGHT (A)		CORNER WEIGHT (B)		CORNER WEIGHT (C)		CORNER WEIGHT (D)		C. G.			HEIGHT
	LBS.	KG.	LBS.	KG.	LBS.	KG.	LBS.	KG.	LBS.	KG.	X	Y	Z	
50GCQ*04	475	215	128	58	120	54	110	50	117	53	36 [914]	22 3/8 [568]	16 1/8 [410]	
50GCQ*05	590	268	162	73	147	67	134	61	148	67	35 3/8 [898]	22 5/16 [557]	16 1/2 [419]	
50GCQ*06	596	270	163	74	148	67	135	61	149	68	35 3/8 [898]	22 5/16 [557]	16 1/2 [419]	

* - STANDARD UNIT WEIGHT IS WITHOUT ELECTRIC HEAT AND WITHOUT PACKAGING.
FOR OTHER OPTIONS AND ACCESSORIES REFER TO THE PRODUCT DATA CATALOG.



THIS DOCUMENT IS THE PROPERTY OF UTC CLIMATE CONTROLS & SECURITY AND IS DELIVERED UPON THE EXPRESS CONDITION THAT THE CONTENTS WILL NOT BE DISCLOSED OR USED WITHOUT WRITTEN CONSENT.

SUBMISSION OF THESE DRAWINGS OR DOCUMENTS DOES NOT CONSTITUTE PART PERFORMANCE OR ACCEPTANCE OF CONTRACT.

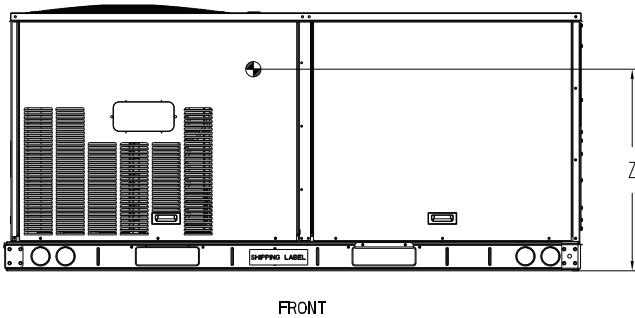
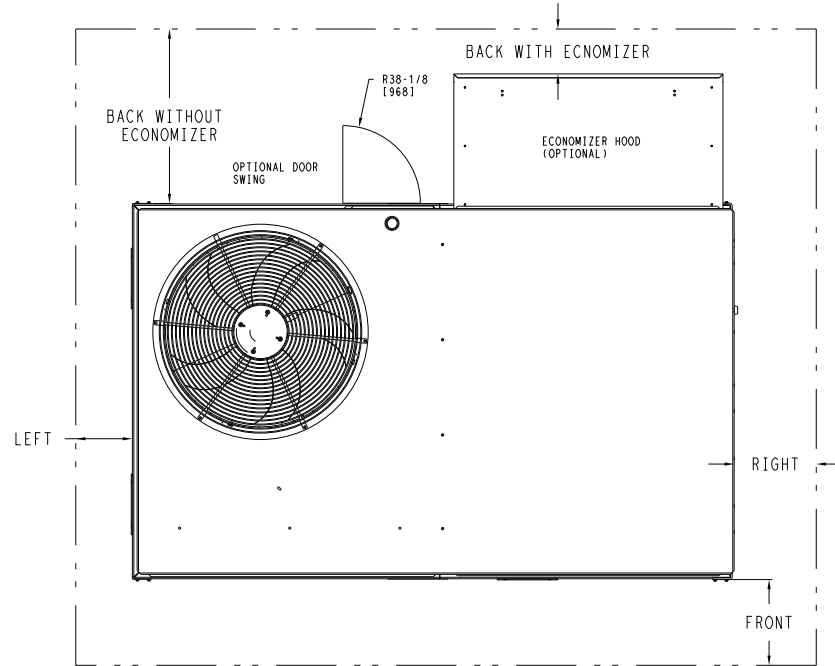
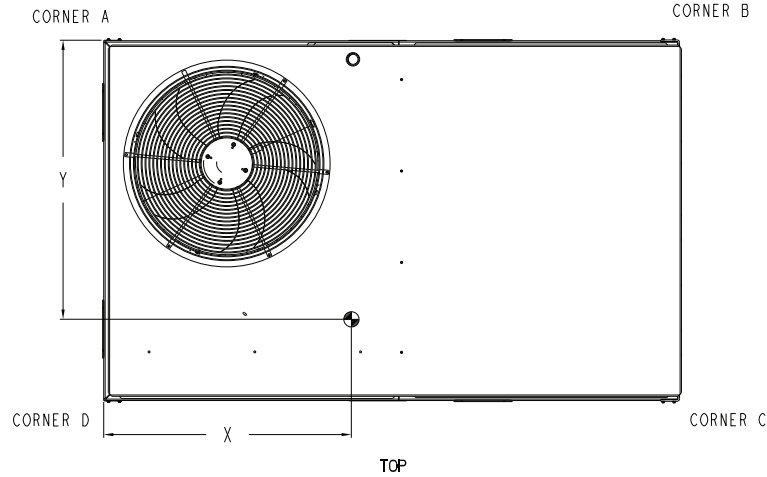

NOTE:
1. FOR ALL MINIMUM CLEARANCES LOCAL CODES OR JURISDICTIONS MAY PREVAIL.

SURFACE	CLEARANCE		OPERATING CLEARANCE
	SERVICE WITH: CONDUCTIVE BARRIER	SERVICE WITH: NONCONDUCTIVE BARRIER	
FRONT	48 [1219mm]	36 [914mm]	18 [457mm]
LEFT	48 [1219mm]	42 [1067mm]	18 [457mm]
BACK W/O ECON	48 [1219mm]	42 [1067mm]	18 [457mm]
BACK W/ECON	36 [914mm]	36 [914mm]	18 [457mm]
RIGHT	36 [914mm]	36 [914mm]	18 [457mm]
TOP	72 [1829mm]	72 [1829mm]	72 [1829mm]

ITC CLASSIFICATION	SHEET	DATE	SUPERCEDES	50GCQ 04-06 SINGLE PACKAGE HEAT PUMP	48TC003351	REV
U.S. ECCN:NSR	2 OF 3	01/09/20	08/15/19			A



50GCQ*04-06 Base Unit Dimensions (cont)



THIS DOCUMENT IS THE PROPERTY OF UTC CLIMATE, CONTROLS & SECURITY AND IS DELIVERED UPON THE EXPRESS CONDITION THAT THE CONTENTS WILL NOT BE DISCLOSED OR USED WITHOUT WRITTEN CONSENT.

SUBMISSION OF THESE DRAWINGS OR DOCUMENTS DOES NOT CONSTITUTE PART PERFORMANCE OR ACCEPTANCE OF CONTRACT.

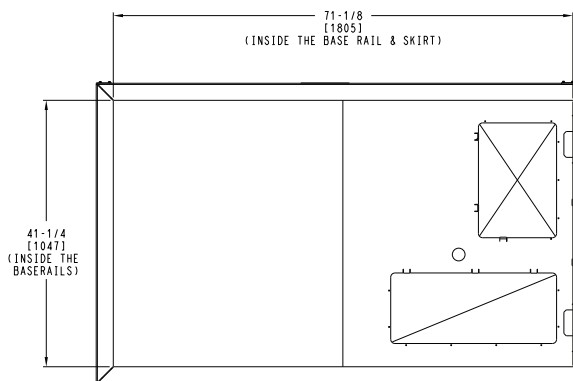
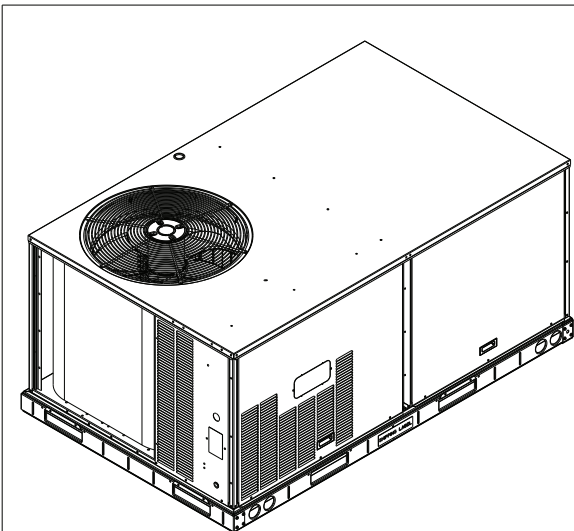

INSIDE BASERAIL DIMENSIONS
BOTTOM

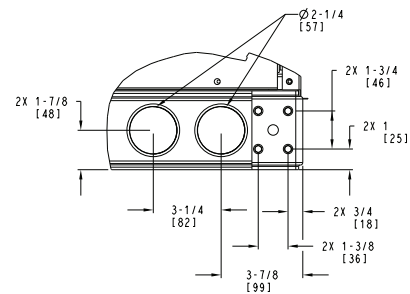

DETAIL C
TYP 4 PLCS

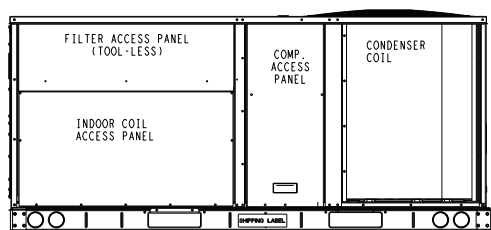

BACK

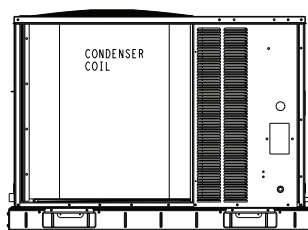

LEFT

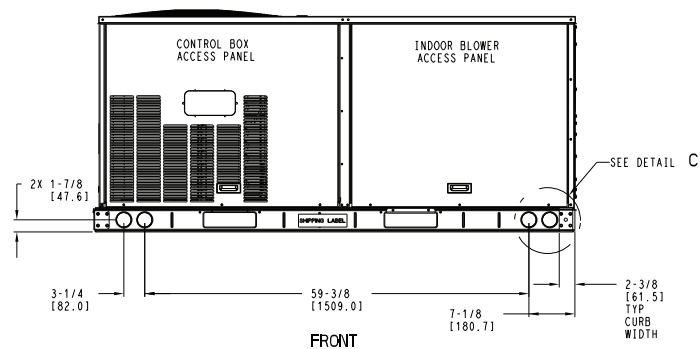

FRONT

ITC CLASSIFICATION U.S. ECCN: NSR	SHEET 3 OF 3	DATE 01/09/20	SUPERCEDES 08/15/19	50GCO 04-06 SINGLE PACKAGE HEAT PUMP	48TC003351	REV A
--------------------------------------	-----------------	------------------	------------------------	--------------------------------------	------------	----------



Roof Curb Dimensions — 50GCQ*04-06

ROOF CURB ACCESSORY #	A
CRRFCURB001A01	14" [356]
CRRFCURB002A01	24" [610]

- NOTES:
1. ROOFCURB ACCESSORY IS SHIPPED DISASSEMBLED.
 2. INSULATED PANELS: 25.4 (1") THK. POLYURETHANE FOAM, 44.5 (1-3/4) # DENSITY.
 3. DIMENSIONS IN [] ARE IN MILLIMETERS.
 4. ROOFCURB: 18 GAGE STEEL.
 5. ATTACH DUCTWORK TO CURB. (FLANGES OF DUCT REST ON CURB).
 6. SERVICE CLEARANCE 4 FEET ON EACH SIDE.
 7. DIRECTION OF AIR FLOW.
 8. CONNECTOR PACKAGE CRBTMPWR001A01 IS FOR THRU-THE-CURB GAS TYPE PACKAGE CRBTMPWR003A01 IS FOR THRU-THE-BOTTOM TYPE GAS CONNECTIONS.

CONNECTOR PKG. ACC.	GAS CONNECTION TYPE	GAS FITTING	POWER WIRING FITTING	CONTROL WIRING FITTING	ACCESSORY CONVENIENCE OUTLET WIRING CONNECTOR
CRBTMPWR001A01	THRU THE CURB	3/4" [19] NPT	3/4" [19] NPT	1/2" [12.7] NPT	1/2" [12.7] NPT
CRBTMPWR003A01	THRU THE BOTTOM	1/2" [12.7] NPT			

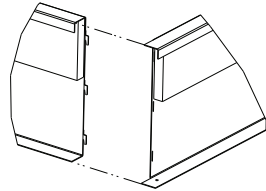
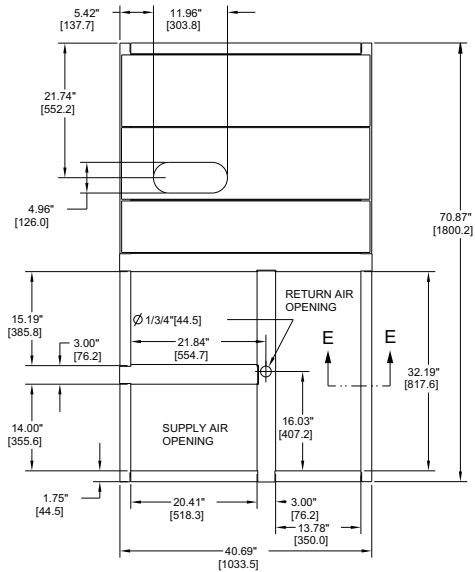

VIEW "B"
CORNER DETAIL

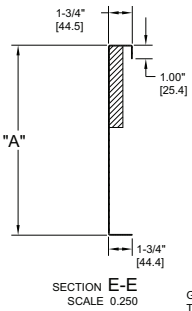
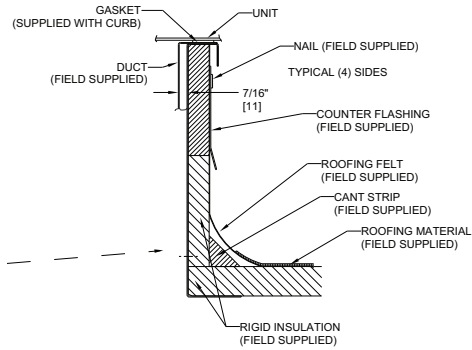

SECTION E-E
SCALE 0.250

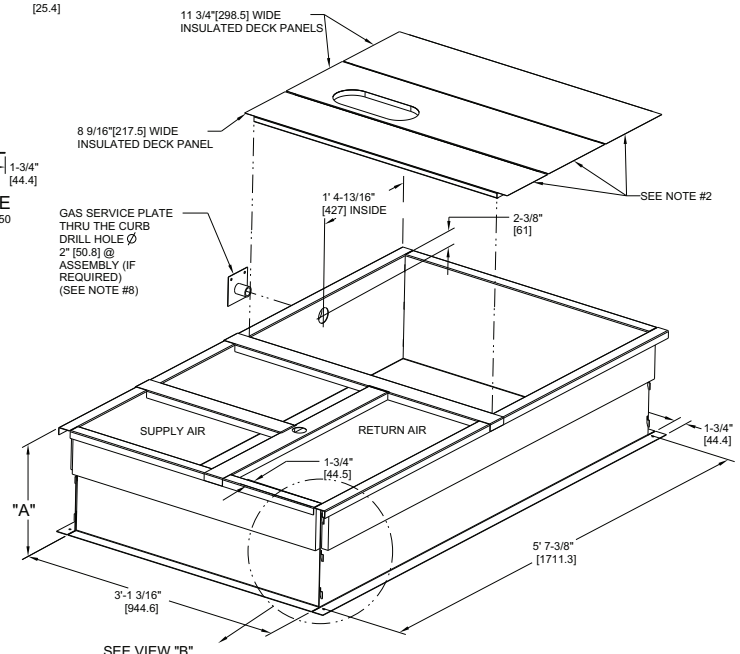

SEE VIEW "B"
CERTIFIED DRAWING

DRAWING RELEASE LEVEL: PRODUCTION		TITLE: CURB ASY, ROOF	
THIRD ANGLE PROJECTION	UNLESS OTHERWISE SPECIFIED DIMENSIONS ARE IN INCHES TOLERANCES ON:		
MATERIAL	1 DEC ±.1	2 DEC ±.05	3 DEC ±.02
ENGINEERING REQUIREMENTS	AUTHORIZATION NUMBER: 1041738		REV: B
WEIGHT: -	ENGINEERING: MMC	MANUFACTURING: 06/17/11	DRAWING NUMBER: 48TC400427
SURFACE FINISH: -	MODEL (INTERNAL USE ONLY)		SHEET 5 OF 5
MFG/PURCH: PURCH	NEXT DRAWING: -		DISTRIBUTION: MMC

REV	REVISION RECORD	DATE	BY	CHKD	APPD	ECN NO.
A	OVERALL DIM. 5'-7 3/8" WAS 5'-7 7/8; 18GA MATERIAL WA 16 GA.; NAIL FIELD SUPPLIED WAS WITH CURB	04/22/13	MMC	-	-	1067898



50GCQ*04 High Stage Cooling Capacities^a

50GCQ*04			AMBIENT TEMPERATURE (°F)																
			85			95			105			115			125				
			EA (db)			EA (db)			EA (db)			EA (db)			EA (db)				
			75	80	85	75	80	85	75	80	85	75	80	85	75	80	85		
900 cfm	EA (wb)	58	TC	31.6	31.6	35.8	29.9	29.9	33.9	28.2	28.2	32.0	26.3	26.3	29.9	24.3	24.3	27.7	
			SHC	27.4	31.6	35.8	25.9	29.9	33.9	24.4	28.2	32.0	22.7	26.3	29.9	20.9	24.3	27.7	
		62	TC	32.9	32.9	33.9	31.2	31.2	33.1	29.0	29.0	31.9	26.6	26.6	30.6	24.8	24.8	27.7	
			SHC	24.5	29.2	33.9	23.7	28.4	33.1	22.5	27.2	31.9	21.3	25.9	30.6	19.2	23.4	27.7	
		67	TC	36.9	36.9	36.9	34.7	34.7	34.7	32.3	32.3	32.3	29.8	29.8	29.8	27.1	27.1	27.1	
			SHC	20.4	25.1	29.7	19.3	24.0	28.6	18.1	22.8	27.5	16.9	21.6	26.3	15.6	20.3	25.1	
	72	TC	40.9	40.9	40.9	38.5	38.5	38.5	36.0	36.0	36.0	33.3	33.3	33.3	30.4	30.4	30.4		
		SHC	15.9	20.4	25.0	14.8	19.3	23.9	13.6	18.2	22.8	12.4	17.0	21.6	11.1	15.8	20.4		
	76	TC	—	44.4	44.4	—	41.9	41.9	—	39.1	39.1	—	36.2	36.2	—	33.1	33.1		
		SHC	—	16.5	21.4	—	15.5	20.4	—	14.4	18.1	—	13.2	17.4	—	12.0	16.3		
	1050 cfm	EA (wb)	58	TC	33.5	33.5	37.9	31.8	31.8	36.0	29.9	29.9	33.9	27.9	27.9	31.7	25.7	25.7	29.3
				SHC	29.1	33.5	37.9	27.5	31.8	36.0	25.8	29.9	33.9	24.1	27.9	31.7	22.2	25.7	29.3
62			TC	34.4	34.4	37.9	32.2	32.2	36.6	30.5	30.5	33.7	28.0	28.0	32.7	25.8	25.8	30.5	
			SHC	27.0	32.4	37.9	25.8	31.2	36.6	23.8	28.8	33.7	22.7	27.7	32.7	21.0	25.8	30.5	
67			TC	38.1	38.1	38.1	35.8	35.8	35.8	33.3	33.3	33.3	30.6	30.6	30.6	27.8	27.8	27.9	
			SHC	21.8	27.2	32.7	20.7	26.1	31.5	19.5	24.9	30.4	18.2	23.7	29.1	17.0	22.4	27.9	
72		TC	42.2	42.2	42.2	39.7	39.7	39.7	37.0	37.0	37.0	34.2	34.2	34.2	31.1	31.1	31.1		
		SHC	16.5	21.8	27.1	15.4	20.7	26.0	14.2	19.5	24.9	13.0	18.3	23.7	11.7	17.1	22.5		
76		TC	—	45.7	45.7	—	43.0	43.0	—	40.2	40.2	—	37.1	37.1	—	33.9	33.9		
		SHC	—	17.3	21.5	—	16.3	20.9	—	15.1	20.0	—	13.9	19.0	—	12.7	17.8		
1200 cfm		EA (wb)	58	TC	35.2	35.2	39.8	33.3	33.3	37.7	31.3	31.3	35.5	29.2	29.2	33.1	26.9	26.9	30.6
				SHC	30.6	35.2	39.8	28.9	33.3	37.7	27.1	31.3	35.5	25.2	29.2	33.1	23.2	26.9	30.6
	62		TC	35.4	35.4	40.9	33.5	33.5	38.9	31.3	31.3	36.9	29.2	29.2	34.5	26.9	26.9	31.9	
			SHC	28.9	34.9	40.9	27.3	33.1	38.9	25.7	31.3	36.9	23.9	29.2	34.5	22.0	26.9	31.9	
	67		TC	39.0	39.0	39.0	36.6	36.6	36.6	34.0	34.0	34.0	31.3	31.3	31.9	28.4	28.4	30.6	
			SHC	23.1	29.3	35.5	22.0	28.1	34.3	20.8	26.9	33.1	19.5	25.7	31.9	18.2	24.4	30.6	
	72	TC	43.2	43.2	43.2	40.5	40.5	40.5	37.8	37.8	37.8	34.8	34.8	34.8	31.7	31.7	31.7		
		SHC	17.1	23.1	29.2	15.9	22.0	28.1	14.7	20.8	26.9	13.5	19.6	25.7	12.2	18.3	24.4		
	76	TC	—	46.7	46.7	—	44.0	44.0	—	41.0	41.0	—	37.8	37.8	—	34.5	34.5		
		SHC	—	18.1	23.5	—	17.0	22.6	—	15.8	21.5	—	14.6	20.4	—	13.3	19.2		
	1350 cfm	EA (wb)	58	TC	36.5	36.5	41.3	34.6	34.6	39.2	32.5	32.5	36.8	30.3	30.3	34.4	27.9	27.9	31.7
				SHC	31.8	36.5	41.3	30.0	34.6	39.2	28.2	32.5	36.8	26.2	30.3	34.4	24.1	27.9	31.7
62			TC	37.1	37.1	40.9	34.6	34.6	40.7	32.5	32.5	38.3	30.3	30.3	35.8	27.9	27.9	33.1	
			SHC	29.2	35.1	40.9	28.5	34.6	40.7	26.8	32.5	38.3	24.8	30.3	35.8	22.8	27.9	33.1	
67			TC	39.8	39.8	39.8	37.2	37.2	37.2	34.6	34.6	35.8	31.8	31.8	34.5	28.8	28.8	33.1	
			SHC	24.4	31.3	38.2	23.2	30.1	37.0	22.0	28.9	35.8	20.7	27.6	34.5	19.4	26.3	33.1	
72		TC	43.9	43.9	43.9	41.2	41.2	41.2	38.4	38.4	38.4	35.3	35.3	35.3	32.1	32.1	32.1		
		SHC	17.6	24.4	31.1	16.4	23.2	30.0	15.2	22.0	28.8	13.9	20.8	27.6	12.6	19.5	26.4		
76		TC	—	47.5	47.5	—	44.6	44.6	—	41.6	41.6	—	38.4	38.4	—	35.0	35.0		
		SHC	—	18.7	25.0	—	17.6	24.0	—	16.4	22.9	—	15.2	21.7	—	13.9	20.5		
1500 cfm		EA (wb)	58	TC	37.8	37.8	42.7	35.7	35.7	40.4	33.6	33.6	38.0	31.2	31.2	35.4	28.8	28.8	32.7
				SHC	32.8	37.8	42.7	31.0	35.7	40.4	29.1	33.6	38.0	27.0	31.2	35.4	24.8	28.8	32.7
	62		TC	37.8	37.8	44.4	35.8	35.8	42.0	33.6	33.6	39.5	31.3	31.3	36.9	28.8	28.8	34.0	
			SHC	31.2	37.8	44.4	29.5	35.8	42.0	27.6	33.6	39.5	25.6	31.3	36.9	23.5	28.8	34.0	
	67		TC	40.4	40.4	40.8	37.8	37.8	39.6	35.1	35.1	38.3	32.2	32.2	37.0	29.2	29.2	35.5	
			SHC	25.6	33.2	40.8	24.4	32.0	39.6	23.2	30.8	38.3	21.9	29.5	37.0	20.5	28.0	35.5	
	72	TC	44.5	44.5	44.5	41.8	41.8	41.8	38.9	38.9	38.9	35.8	35.8	35.8	32.5	32.5	32.5		
		SHC	18.0	25.5	33.0	16.9	24.4	31.9	15.6	23.2	30.7	14.4	21.9	29.5	13.1	20.6	28.2		
	76	TC	—	48.1	48.1	—	45.3	45.3	—	42.1	42.1	—	38.8	38.8	—	35.4	35.4		
		SHC	—	19.3	26.3	—	18.1	25.3	—	16.9	24.2	—	15.7	23.0	—	14.4	21.8		

NOTE(S):

a. See minimum-maximum airflow ratings on page 7.

LEGEND

- Do Not Operate
- cfm — Cubic Feet Per Minute (Supply Air)
- EA (db) — Entering Air Temperature (dry bulb)
- EA (wb) — Entering Air Temperature (wet bulb)
- SHC — Sensible Heat Capacity (1000 Btuh) Gross
- TC — Total Capacity (1000 Btuh) Gross

50GCQ*04 Low Stage Cooling Capacities^a

50GCQ*04			AMBIENT TEMPERATURE (°F)																
			85			95			105			115			125				
			EA (db)			EA (db)			EA (db)			EA (db)			EA (db)				
			75	80	85	75	80	85	75	80	85	75	80	85	75	80	85		
			750 cfm	EA (wb)	58	TC	24.5	24.5	27.5	23.6	23.6	26.5	22.7	22.7	25.4	21.5	21.5	24.1	20.3
SHC	21.5	24.5				27.5	20.8	23.6	26.5	20.0	22.7	25.4	19.0	21.5	24.1	17.9	20.3	22.6	
62	TC	24.9			24.9	27.7	23.8	23.8	27.2	22.8	22.8	25.6	21.6	21.6	24.9	20.3	20.3	23.4	
	SHC	20.2			23.9	27.7	19.7	23.4	27.2	18.7	22.2	25.6	18.2	21.6	24.9	17.2	20.3	23.4	
67	TC	27.2			27.2	27.2	26.0	26.0	26.0	24.6	24.6	24.6	23.0	23.0	23.0	21.3	21.3	22.2	
	SHC	16.4			20.1	23.9	16.0	19.8	23.6	15.6	19.4	23.2	15.2	19.0	22.8	14.6	18.4	22.2	
72	TC	29.8		29.8	29.8	28.4	28.4	28.4	26.9	26.9	26.9	25.2	25.2	25.2	23.3	23.3	23.3		
	SHC	12.5		16.1	19.8	12.1	15.8	19.5	11.7	15.4	19.1	11.3	15.0	18.8	10.8	14.5	18.3		
76	TC	—		32.0	32.0	—	30.5	30.5	—	28.9	28.9	—	27.1	27.1	—	25.1	25.1		
	SHC	—		12.8	17.0	—	12.5	15.6	—	12.2	15.5	—	11.8	15.3	—	11.3	14.9		
900 cfm	EA (wb)	58		TC	25.8	25.8	29.0	24.9	24.9	27.9	23.8	23.8	26.6	22.6	22.6	25.2	21.2	21.2	23.6
				SHC	22.6	25.8	29.0	21.8	24.9	27.9	20.9	23.8	26.6	19.9	22.6	25.2	18.7	21.2	23.6
		62	TC	25.9	25.9	29.8	24.9	24.9	28.9	23.8	23.8	27.6	22.6	22.6	26.1	21.2	21.2	24.5	
			SHC	21.5	25.6	29.8	20.9	24.9	28.9	20.0	23.8	27.6	19.0	22.6	26.1	17.9	21.2	24.5	
		67	TC	27.9	27.9	27.9	26.6	26.6	26.6	25.1	25.1	25.7	23.5	23.5	25.2	21.7	21.7	24.7	
			SHC	17.5	22.0	26.5	17.2	21.7	26.1	16.8	21.2	25.7	16.3	20.8	25.2	15.7	20.2	24.7	
	72	TC	30.6	30.6	30.6	29.1	29.1	29.1	27.5	27.5	27.5	25.7	25.7	25.7	23.7	23.7	23.7		
		SHC	12.9	17.3	21.7	12.6	17.0	21.3	12.2	16.6	21.0	11.7	16.2	20.6	11.2	15.7	20.1		
	76	TC	—	32.8	32.8	—	31.2	31.2	—	29.5	29.5	—	27.6	27.6	—	25.5	25.5		
		SHC	—	13.4	17.4	—	13.1	17.1	—	12.7	16.9	—	12.3	16.6	—	11.9	16.2		
	1050 cfm	EA (wb)	58	TC	26.9	26.9	30.2	25.8	25.8	29.0	24.7	24.7	27.7	23.4	23.4	26.1	21.9	21.9	24.4
				SHC	23.6	26.9	30.2	22.7	25.8	29.0	21.7	24.7	27.7	20.6	23.4	26.1	19.3	21.9	24.4
62			TC	26.9	26.9	31.3	25.9	25.9	30.1	24.7	24.7	28.7	23.4	23.4	27.1	21.9	21.9	25.3	
			SHC	22.5	26.9	31.3	21.7	25.9	30.1	20.7	24.7	28.7	19.7	23.4	27.1	18.5	21.9	25.3	
67			TC	28.5	28.5	29.0	27.1	27.1	28.6	25.5	25.5	28.1	23.8	23.8	27.6	22.0	22.0	26.7	
			SHC	18.7	23.8	29.0	18.3	23.4	28.6	17.8	23.0	28.1	17.3	22.4	27.6	16.7	21.7	26.7	
72		TC	31.1	31.1	31.1	29.6	29.6	29.6	27.9	27.9	27.9	26.1	26.1	26.1	24.0	24.0	24.0		
		SHC	13.3	18.4	23.5	13.0	18.1	23.1	12.6	17.7	22.8	12.1	17.2	22.4	11.6	16.8	21.9		
76		TC	—	33.4	33.4	—	31.8	31.8	—	30.0	30.0	—	28.0	28.0	—	25.9	25.9		
		SHC	—	14.0	18.7	—	13.7	18.5	—	13.3	18.1	—	12.9	17.8	—	12.4	17.4		
1200 cfm		EA (wb)	58	TC	27.8	27.8	31.2	26.7	26.7	29.9	25.4	25.4	28.5	24.0	24.0	26.9	22.5	22.5	25.1
				SHC	24.3	27.8	31.2	23.4	26.7	29.9	22.3	25.4	28.5	21.2	24.0	26.9	19.8	22.5	25.1
	62		TC	27.8	27.8	32.4	26.7	26.7	31.0	25.4	25.4	29.5	24.0	24.0	27.9	22.5	22.5	26.0	
			SHC	23.2	27.8	32.4	22.3	26.7	31.0	21.3	25.4	29.5	20.2	24.0	27.9	19.0	22.5	26.0	
	67		TC	28.9	28.9	31.3	27.4	27.4	30.9	25.9	25.9	30.3	24.1	24.1	29.4	22.7	22.7	26.4	
			SHC	19.7	25.5	31.3	19.3	25.1	30.9	18.8	24.6	30.3	18.2	23.8	29.4	16.7	21.5	26.4	
	72	TC	31.5	31.5	31.5	30.0	30.0	30.0	28.2	28.2	28.2	26.3	26.3	26.3	24.3	24.3	24.3		
		SHC	13.7	19.5	25.2	13.4	19.1	24.9	12.9	18.7	24.5	12.5	18.3	24.1	12.0	17.8	23.6		
	76	TC	—	33.8	33.8	—	32.2	32.2	—	30.3	30.3	—	28.3	28.3	—	26.1	26.1		
		SHC	—	14.4	19.9	—	14.1	19.7	—	13.8	19.3	—	13.4	19.0	—	12.9	18.6		
	1350 cfm	EA (wb)	58	TC	28.5	28.5	32.0	27.3	27.3	30.7	26.0	26.0	29.2	24.6	24.6	27.5	23.0	23.0	25.7
				SHC	25.0	28.5	32.0	24.0	27.3	30.7	22.9	26.0	29.2	21.6	24.6	27.5	20.2	23.0	25.7
62			TC	28.5	28.5	33.3	27.4	27.4	31.8	26.1	26.1	30.3	24.6	24.6	28.5	23.0	23.0	26.6	
			SHC	23.8	28.5	33.3	22.9	27.4	31.8	21.8	26.1	30.3	20.7	24.6	28.5	19.4	23.0	26.6	
67			TC	29.2	29.2	33.5	27.7	27.7	33.0	26.2	26.2	32.0	25.0	25.0	28.0	23.0	23.0	28.4	
			SHC	20.7	27.1	33.5	20.3	26.6	33.0	19.6	25.8	32.0	17.7	22.9	28.0	17.6	23.0	28.4	
72		TC	31.9	31.9	31.9	30.3	30.3	30.3	28.5	28.5	28.5	26.6	26.6	26.6	24.0	24.0	24.9		
		SHC	14.1	20.5	26.9	13.7	20.2	26.6	13.3	19.8	26.2	12.9	19.3	25.8	12.0	18.5	24.9		
76		TC	—	34.2	34.2	—	32.5	32.5	—	30.6	30.6	—	28.5	28.5	—	26.3	26.3		
		SHC	—	14.9	21.1	—	14.6	20.8	—	14.2	20.5	—	13.8	20.1	—	13.4	19.7		

NOTE(S):

a. See minimum-maximum airflow ratings on page 7.

LEGEND

- Do Not Operate
- cfm — Cubic Feet Per Minute (Supply Air)
- EA (db) — Entering Air Temperature (dry bulb)
- EA (wb) — Entering Air Temperature (wet bulb)
- SHC — Sensible Heat Capacity (1000 Btuh) Gross
- TC — Total Capacity (1000 Btuh) Gross



50GCQ*05 High Stage Cooling Capacities^a

50GCQ*05			AMBIENT TEMPERATURE (°F)																
			85			95			105			115			125				
			EA (db)			EA (db)			EA (db)			EA (db)			EA (db)				
			75	80	85	75	80	85	75	80	85	75	80	85	75	80	85		
1200 cfm	EA (wb)	58	TC	42.2	42.2	48.0	39.7	39.7	45.3	37.1	37.1	42.4	34.4	34.4	39.4	31.5	31.5	36.2	
			SHC	36.5	42.2	48.0	34.2	39.7	45.3	31.8	37.1	42.4	29.3	34.4	39.4	26.7	31.5	36.2	
		62	TC	44.8	44.8	45.5	43.2	43.2	43.2	38.5	38.5	41.8	35.2	35.2	39.8	31.6	31.6	37.6	
			SHC	32.8	39.1	45.5	30.2	36.1	42.0	29.1	35.4	41.8	27.2	33.5	39.8	25.1	31.3	37.6	
		67	TC	49.9	49.9	49.9	46.6	46.6	46.6	43.2	43.2	43.2	39.6	39.6	39.6	35.8	35.8	35.8	
			SHC	26.9	33.2	39.5	25.0	31.4	37.7	23.2	29.5	35.8	21.3	27.6	33.9	19.3	25.7	32.0	
	72	TC	55.4	55.4	55.4	51.9	51.9	51.9	48.3	48.3	48.3	44.4	44.4	44.4	40.3	40.3	40.3		
		SHC	20.9	27.0	33.2	19.1	25.3	31.5	17.2	23.4	29.7	15.3	21.5	27.8	13.3	19.6	25.9		
	76	TC	—	60.2	60.2	—	56.5	56.5	—	52.6	52.6	—	48.5	48.5	—	44.2	44.2		
		SHC	—	21.9	28.5	—	20.2	26.8	—	18.5	24.0	—	16.6	22.5	—	14.7	20.7		
	1400 cfm	EA (wb)	58	TC	38.9	45.0	51.1	36.5	42.3	48.2	34.0	39.5	45.1	31.3	36.6	41.9	28.6	33.5	38.5
				SHC	46.5	46.5	50.4	43.3	43.3	48.5	40.0	40.0	46.4	37.0	37.0	43.2	33.6	33.6	40.2
62			TC	35.8	43.1	50.4	33.9	41.2	48.5	31.9	39.2	46.4	29.4	36.3	43.2	26.9	33.6	40.2	
			SHC	51.6	51.6	51.6	48.2	48.2	48.2	44.6	44.6	44.6	40.8	40.8	40.8	36.8	36.8	36.8	
67			TC	28.8	36.1	43.4	27.0	34.3	41.6	25.1	32.4	39.7	23.1	30.5	37.8	21.1	28.5	35.8	
			SHC	57.2	57.2	57.2	53.5	53.5	53.5	49.7	49.7	49.7	45.7	45.7	45.7	41.4	41.4	41.4	
72		TC	21.8	28.9	36.1	19.9	27.1	34.3	18.0	25.3	32.5	16.1	23.3	30.6	14.1	21.4	28.6		
		SHC	—	62.0	62.0	—	58.1	58.1	—	54.1	54.1	—	49.8	49.8	—	45.3	45.3		
76		TC	—	23.1	29.4	—	21.3	28.0	—	19.5	26.3	—	17.6	24.6	—	15.6	22.7		
		SHC	38.9	45.0	51.1	36.5	42.3	48.2	34.0	39.5	45.1	31.3	36.6	41.9	28.6	33.5	38.5		
1600 cfm		EA (wb)	58	TC	47.3	47.3	53.7	44.5	44.5	50.6	41.6	41.6	47.4	38.5	38.5	44.0	35.2	35.2	40.4
				SHC	40.9	47.3	53.7	38.4	44.5	50.6	35.8	41.6	47.4	33.0	38.5	44.0	30.1	35.2	40.4
	62		TC	47.9	47.9	55.0	45.0	45.0	51.7	41.8	41.8	49.0	38.6	38.6	45.9	35.3	35.3	42.2	
			SHC	38.5	46.7	55.0	36.0	43.9	51.7	33.7	41.3	49.0	31.2	38.6	45.9	28.4	35.3	42.2	
	67		TC	52.9	52.9	52.9	49.4	49.4	49.4	45.7	45.7	45.7	41.8	41.8	41.8	37.7	37.7	39.5	
			SHC	30.6	38.9	47.2	28.8	37.1	45.4	26.8	35.2	43.5	24.9	33.2	41.5	22.8	31.2	39.5	
	72	TC	58.6	58.6	58.6	54.8	54.8	54.8	50.8	50.8	50.8	46.6	46.6	46.6	42.2	42.2	42.2		
		SHC	22.5	30.7	38.9	20.6	28.9	37.1	18.7	27.0	35.2	16.8	25.0	33.3	14.7	23.0	31.3		
	76	TC	—	63.4	63.4	—	59.4	59.4	—	55.2	55.2	—	50.8	50.8	—	46.2	46.2		
		SHC	—	24.0	31.7	—	22.2	30.1	—	20.4	28.3	—	18.4	26.5	—	16.4	24.5		
	1800 cfm	EA (wb)	58	TC	49.3	49.3	55.9	46.4	46.4	52.7	43.3	43.3	49.3	40.1	40.1	45.8	36.7	36.7	42.0
				SHC	42.7	49.3	55.9	40.1	46.4	52.7	37.3	43.3	49.3	34.4	40.1	45.8	31.3	36.7	42.0
62			TC	49.7	49.7	57.5	46.4	46.4	54.9	43.4	43.4	51.4	40.2	40.2	47.8	36.7	36.7	43.9	
			SHC	40.2	48.9	57.5	38.0	46.4	54.9	35.3	43.4	51.4	32.5	40.2	47.8	29.6	36.7	43.9	
67			TC	54.0	54.0	54.0	50.3	50.3	50.3	46.5	46.5	47.1	42.5	42.5	45.2	38.3	38.3	43.1	
			SHC	32.4	41.6	50.9	30.5	39.8	49.0	28.5	37.8	47.1	26.6	35.9	45.2	24.5	33.8	43.1	
72		TC	59.7	59.7	59.7	55.8	55.8	55.8	51.7	51.7	51.7	47.4	47.4	47.4	42.9	42.9	42.9		
		SHC	23.2	32.4	41.5	21.3	30.5	39.7	19.4	28.6	37.8	17.4	26.6	35.9	15.3	24.6	33.8		
76		TC	—	64.5	64.5	—	60.4	60.4	—	56.1	56.1	—	51.6	51.6	—	46.8	46.8		
		SHC	—	24.8	33.7	—	23.0	31.9	—	21.1	30.1	—	19.2	28.2	—	17.1	26.2		
2000 cfm		EA (wb)	58	TC	51.0	51.0	57.8	48.0	48.0	54.5	44.8	44.8	51.0	41.5	41.5	47.3	37.9	37.9	43.4
				SHC	44.2	51.0	57.8	41.5	48.0	54.5	38.6	44.8	51.0	35.6	41.5	47.3	32.4	37.9	43.4
	62		TC	51.1	51.1	60.1	48.0	48.0	56.7	44.9	44.9	53.1	41.5	41.5	49.3	38.0	38.0	45.3	
			SHC	42.0	51.1	60.1	39.4	48.0	56.7	36.6	44.9	53.1	33.7	41.5	49.3	30.6	38.0	45.3	
	67		TC	54.9	54.9	54.9	51.1	51.1	52.6	47.2	47.2	50.6	43.1	43.1	48.6	38.9	38.9	46.4	
			SHC	34.0	44.2	54.5	32.1	42.3	52.6	30.2	40.4	50.6	28.2	38.4	48.6	26.1	36.2	46.4	
	72	TC	60.5	60.5	60.5	56.6	56.6	56.6	52.4	52.4	52.4	48.2	48.2	48.2	43.4	43.4	43.4		
		SHC	23.8	33.9	44.0	21.9	32.0	42.2	19.9	30.1	40.3	18.0	28.2	38.4	15.9	26.1	36.3		
	76	TC	—	65.4	65.4	—	61.2	61.2	—	56.9	56.9	—	52.3	52.3	—	47.4	47.4		
		SHC	—	25.6	35.4	—	23.7	33.6	—	21.8	31.7	—	19.8	29.8	—	17.8	27.8		

NOTE(S):

a. See minimum-maximum airflow ratings on page 7.

LEGEND

- Do Not Operate
- cfm Cubic Feet Per Minute (Supply Air)
- EA (db) Entering Air Temperature (dry bulb)
- EA (wb) Entering Air Temperature (wet bulb)
- SHC Sensible Heat Capacity (1000 Btuh) Gross
- TC Total Capacity (1000 Btuh) Gross



50GCQ*05 Low Stage Cooling Capacities^a

50GCQ*05			AMBIENT TEMPERATURE (°F)																
			85			95			105			115			125				
			EA (db)			EA (db)			EA (db)			EA (db)			EA (db)				
1000 cfm	EA (wb)	58	TC	80	85	75	80	85	75	80	85	75	80	85	75	80	85		
			SHC	27.3	31.5	35.6	25.8	29.7	33.6	24.0	27.7	31.5	22.1	25.6	29.1	23.2	23.2	26.4	
62	TC	32.2	32.2	35.7	30.1	30.1	34.4	27.8	27.8	32.8	25.6	25.6	30.3	23.2	23.2	27.6			
	SHC	25.5	30.6	35.7	24.2	29.3	34.4	22.8	27.8	32.8	20.9	25.6	30.3	18.9	23.2	27.6			
67	TC	35.9	35.9	35.9	33.6	33.6	33.6	31.0	31.0	31.0	28.2	28.2	28.2	25.0	25.0	25.8			
	SHC	20.6	25.8	30.9	19.5	24.6	29.8	18.3	23.4	28.5	17.0	22.1	27.3	15.5	20.7	25.8			
72	TC	39.9	39.9	39.9	37.4	37.4	37.4	34.7	34.7	34.7	31.7	31.7	31.7	28.4	28.4	28.4			
	SHC	15.7	20.7	25.8	14.6	19.6	24.7	13.4	18.4	23.5	12.1	17.2	22.2	10.7	15.8	20.9			
76	TC	—	43.3	43.3	—	40.7	40.7	—	37.8	37.8	—	34.7	34.7	—	31.2	31.2			
	SHC	—	16.6	21.0	—	15.6	20.2	—	14.4	19.2	—	13.1	18.0	—	11.8	16.0			
1200 cfm	EA (wb)	58	TC	33.7	33.7	38.0	31.7	31.7	35.9	29.7	29.7	33.6	27.3	27.3	31.1	24.8	24.8	28.2	
			SHC	29.3	33.7	38.0	27.6	31.7	35.9	25.7	29.7	33.6	23.6	27.3	31.1	21.3	24.8	28.2	
		62	TC	33.8	33.8	39.3	31.5	31.5	37.3	29.7	29.7	35.0	27.4	27.4	32.3	24.8	24.8	29.4	
			SHC	27.7	33.5	39.3	25.7	31.5	37.3	24.4	29.7	35.0	22.4	27.4	32.3	20.2	24.8	29.4	
		67	TC	37.2	37.2	37.2	34.7	34.7	34.7	32.0	32.0	32.2	29.0	29.0	30.8	25.8	25.8	29.4	
			SHC	22.4	28.5	34.5	21.2	27.3	33.4	20.0	26.1	32.2	18.6	24.7	30.8	17.2	23.3	29.4	
	72	TC	41.2	41.2	41.2	38.6	38.6	38.6	35.7	35.7	35.7	32.6	32.6	32.6	29.1	29.1	29.1		
		SHC	16.5	22.5	28.4	15.3	21.3	27.3	14.1	20.1	26.1	12.8	18.8	24.9	11.4	17.4	23.5		
	76	TC	—	44.6	44.6	—	41.9	41.9	—	38.9	38.9	—	35.6	35.6	—	32.1	32.1		
		SHC	—	17.6	23.2	—	16.5	22.2	—	15.3	21.1	—	14.0	19.9	—	12.7	18.6		
	1400 cfm	EA (wb)	58	TC	35.4	35.4	40.0	33.4	33.4	37.8	31.2	31.2	35.3	28.7	28.7	32.6	26.0	26.0	29.6
				SHC	30.8	35.4	40.0	29.0	33.4	37.8	27.0	31.2	35.3	24.9	28.7	32.6	22.5	26.0	29.6
62			TC	35.5	35.5	41.6	33.4	33.4	39.3	31.2	31.2	36.7	28.8	28.8	33.9	26.1	26.1	30.8	
			SHC	29.3	35.5	41.6	27.6	33.4	39.3	25.7	31.2	36.7	23.6	28.8	33.9	21.3	26.1	30.8	
67			TC	38.0	38.0	38.0	35.5	35.5	37.0	32.7	32.7	35.6	29.7	29.7	34.2	26.4	26.4	32.5	
			SHC	24.0	31.0	38.0	22.9	30.0	37.0	21.6	28.6	35.6	20.2	27.2	34.2	18.7	25.6	32.5	
72		TC	42.1	42.1	42.1	39.4	39.4	39.4	36.4	36.4	36.4	33.2	33.2	33.2	29.7	29.7	29.7		
		SHC	17.1	24.1	31.0	16.0	22.9	29.8	14.7	21.7	28.6	13.4	20.4	27.4	12.0	19.0	26.0		
76		TC	—	45.6	45.6	—	42.8	42.8	—	39.7	39.7	—	36.3	36.3	—	32.6	32.6		
		SHC	—	18.4	25.1	—	17.3	24.0	—	16.1	22.9	—	14.8	21.6	—	13.5	20.3		
1600 cfm		EA (wb)	58	TC	36.9	36.9	41.6	34.7	34.7	39.3	32.4	32.4	36.7	29.9	29.9	33.9	27.1	27.1	30.8
				SHC	32.1	36.9	41.6	30.2	34.7	39.3	28.1	32.4	36.7	25.9	29.9	33.9	23.4	27.1	30.8
	62		TC	36.9	36.9	43.3	34.8	34.8	40.9	32.5	32.5	38.3	29.9	29.9	35.3	27.1	27.1	32.0	
			SHC	30.5	36.9	43.3	28.7	34.8	40.9	26.8	32.5	38.3	24.5	29.9	35.3	22.2	27.1	32.0	
	67		TC	38.7	38.7	41.4	36.1	36.1	40.2	33.3	33.3	38.8	30.2	30.2	37.2	27.2	27.2	34.3	
			SHC	25.6	33.5	41.4	24.4	32.3	40.2	23.1	31.0	38.8	21.7	29.4	37.2	19.7	27.0	34.3	
	72	TC	42.8	42.8	42.8	40.0	40.0	40.0	37.0	37.0	37.0	33.7	33.7	33.7	30.1	30.1	30.1		
		SHC	17.8	25.6	33.4	16.6	24.4	32.2	15.3	23.2	31.0	14.0	21.9	29.8	12.6	20.5	28.4		
	76	TC	—	46.3	46.3	—	43.4	43.4	—	40.4	40.4	—	36.8	36.8	—	33.1	33.1		
		SHC	—	19.2	26.8	—	18.0	25.7	—	16.9	24.6	—	15.5	23.3	—	14.1	21.9		
	1800 cfm	EA (wb)	58	TC	38.1	38.1	43.0	35.9	35.9	40.6	33.5	33.5	37.9	30.8	30.8	35.0	27.9	27.9	31.7
				SHC	33.2	38.1	43.0	31.2	35.9	40.6	29.1	33.5	37.9	26.7	30.8	35.0	24.1	27.9	31.7
62			TC	38.1	38.1	44.7	35.9	35.9	42.2	33.5	33.5	39.4	30.9	30.9	36.4	27.9	27.9	33.0	
			SHC	31.5	38.1	44.7	29.7	35.9	42.2	27.6	33.5	39.4	25.3	30.9	36.4	22.9	27.9	33.0	
67			TC	39.3	39.3	44.5	36.6	36.6	43.2	34.4	34.4	38.6	31.1	31.1	38.3	28.0	28.0	35.6	
			SHC	27.1	35.8	44.5	25.8	34.5	43.2	23.2	30.9	38.6	22.3	30.3	38.3	20.4	28.0	35.6	
72		TC	43.4	43.4	43.4	40.6	40.6	40.6	37.5	37.5	37.5	34.1	34.1	34.1	30.5	30.5	30.7		
		SHC	18.3	27.0	35.7	17.1	25.9	34.6	15.9	24.6	33.4	14.6	23.3	32.1	13.2	21.9	30.7		
76		TC	—	46.9	46.9	—	44.0	44.0	—	40.7	40.7	—	37.3	37.3	—	33.4	33.4		
		SHC	—	19.8	28.3	—	18.7	27.2	—	17.5	26.0	—	16.2	24.8	—	14.8	23.4		

NOTE(S):

a. See minimum-maximum airflow ratings on page 7.

LEGEND

- Do Not Operate
- cfm — Cubic Feet Per Minute (Supply Air)
- EA (db) — Entering Air Temperature (dry bulb)
- EA (wb) — Entering Air Temperature (wet bulb)
- SHC — Sensible Heat Capacity (1000 Btuh) Gross
- TC — Total Capacity (1000 Btuh) Gross

50GCQ*06 High Stage Cooling Capacities^a

50GCQ*06			AMBIENT TEMPERATURE (°F)																
			85			95			105			115			125				
			EA (db)			EA (db)			EA (db)			EA (db)			EA (db)				
			75	80	85	75	80	85	75	80	85	75	80	85	75	80	85		
1500 cfm	EA (wb)	58	TC	52.7	52.7	59.8	49.2	49.2	56.0	45.6	45.6	52.0	41.7	41.7	47.6	37.8	37.8	43.3	
			SHC	45.5	52.7	59.8	42.5	49.2	56.0	39.3	45.6	52.0	35.8	41.7	47.6	32.3	37.8	43.3	
		62	TC	55.3	55.3	57.6	51.1	51.1	55.4	46.5	46.5	53.0	41.8	41.8	49.7	37.9	37.9	45.2	
			SHC	41.3	49.5	57.6	39.1	47.2	55.4	36.7	44.9	53.0	33.9	41.8	49.7	30.6	37.9	45.2	
		67	TC	61.8	61.8	61.8	57.9	57.9	57.9	53.1	53.1	53.1	48.3	48.3	48.3	43.1	43.1	43.1	
			SHC	33.7	41.8	50.0	31.7	39.9	48.1	29.4	37.6	45.8	27.2	35.4	43.5	24.8	33.0	41.2	
	72	TC	69.4	69.4	69.4	64.9	64.9	64.9	60.4	60.4	60.4	55.4	55.4	55.4	49.9	49.9	49.9		
		SHC	26.1	34.3	42.5	24.0	32.2	40.4	22.0	30.2	38.3	19.8	28.0	36.2	17.5	25.7	33.9		
	76	TC	—	75.6	75.6	—	71.4	71.4	—	66.7	66.7	—	61.8	61.8	—	55.9	55.9		
		SHC	—	28.0	36.2	—	26.1	34.3	—	24.1	32.4	—	22.1	30.3	—	19.7	27.9		
	1750 cfm	EA (wb)	58	TC	56.2	56.2	63.8	52.8	52.8	59.9	49.1	49.1	55.9	45.2	45.2	51.5	41.1	41.1	46.9
				SHC	48.6	56.2	63.8	45.6	52.8	59.9	42.3	49.1	55.9	38.8	45.2	51.5	35.2	41.1	46.9
62			TC	57.4	57.4	64.1	53.2	53.2	61.8	49.2	49.2	58.3	45.3	45.3	53.7	41.1	41.1	49.0	
			SHC	45.2	54.6	64.1	42.9	52.4	61.8	40.1	49.2	58.3	36.8	45.3	53.7	33.3	41.1	49.0	
67			TC	64.0	64.0	64.0	59.8	59.8	59.8	55.2	55.2	55.2	50.0	50.0	50.0	44.7	44.7	46.3	
			SHC	36.2	45.7	55.2	34.2	43.7	53.2	32.0	41.5	51.0	29.6	39.1	48.7	27.3	36.8	46.3	
72		TC	71.9	71.9	71.9	67.3	67.3	67.3	62.4	62.4	62.4	57.5	57.5	57.5	51.6	51.6	51.6		
		SHC	27.2	36.8	46.3	25.2	34.7	44.3	23.0	32.5	42.0	20.9	30.4	40.0	18.5	28.0	37.5		
76		TC	—	77.7	77.7	—	73.5	73.5	—	68.8	68.8	—	63.9	63.9	—	58.0	58.0		
		SHC	—	29.1	38.8	—	27.3	36.9	—	25.4	35.0	—	23.3	33.0	—	21.0	30.6		
2000 cfm		EA (wb)	58	TC	59.2	59.2	67.1	55.9	55.9	63.5	51.9	51.9	59.0	47.8	47.8	54.5	43.6	43.6	49.8
				SHC	51.3	59.2	67.1	48.3	55.9	63.5	44.7	51.9	59.0	41.2	47.8	54.5	37.4	43.6	49.8
	62		TC	59.3	59.3	69.9	56.0	56.0	66.1	51.9	51.9	61.5	47.9	47.9	56.8	43.7	43.7	52.0	
			SHC	48.7	59.3	69.9	45.9	56.0	66.1	42.4	51.9	61.5	39.0	47.9	56.8	35.4	43.7	52.0	
	67		TC	65.7	65.7	65.7	61.4	61.4	61.4	56.9	56.9	56.9	51.3	51.3	53.6	45.9	45.9	51.2	
			SHC	38.6	49.4	60.2	36.5	47.3	58.2	34.4	45.3	56.1	32.0	42.8	53.6	29.6	40.4	51.2	
	72	TC	73.7	73.7	73.7	69.1	69.1	69.1	64.1	64.1	64.1	58.9	58.9	58.9	52.9	52.9	52.9		
		SHC	28.1	39.0	49.9	26.1	37.0	47.9	24.0	34.9	45.7	21.8	32.6	43.5	19.4	30.2	41.1		
	76	TC	—	79.2	79.2	—	75.0	75.0	—	70.3	70.3	—	65.3	65.3	—	59.5	59.5		
		SHC	—	30.1	41.0	—	28.3	39.3	—	26.4	37.4	—	24.4	35.4	—	22.2	33.1		
	2250 cfm	EA (wb)	58	TC	61.8	61.8	70.0	58.3	58.3	66.2	54.3	54.3	61.7	50.0	50.0	57.0	45.7	45.7	52.2
				SHC	53.5	61.8	70.0	50.4	58.3	66.2	46.9	54.3	61.7	43.1	50.0	57.0	39.3	45.7	52.2
62			TC	61.9	61.9	72.9	58.4	58.4	68.9	54.4	54.4	64.3	50.1	50.1	59.4	45.8	45.8	54.4	
			SHC	50.8	61.9	72.9	47.9	58.4	68.9	44.5	54.4	64.3	40.9	50.1	59.4	37.1	45.8	54.4	
67			TC	67.2	67.2	67.2	62.6	62.6	63.0	58.0	58.0	60.9	52.4	52.4	58.5	46.9	46.9	56.0	
			SHC	40.9	53.0	65.2	38.8	50.9	63.0	36.7	48.8	60.9	34.3	46.4	58.5	31.9	43.9	56.0	
72		TC	75.1	75.1	75.1	70.5	70.5	70.5	65.4	65.4	65.4	60.1	60.1	60.1	53.9	53.9	53.9		
		SHC	28.9	41.0	53.2	26.9	39.1	51.3	24.8	37.0	49.2	22.6	34.8	47.0	20.2	32.3	44.5		
76		TC	—	80.3	80.3	—	76.1	76.1	—	71.4	71.4	—	66.4	66.4	—	60.7	60.7		
		SHC	—	30.9	43.0	—	29.2	41.4	—	27.3	39.6	—	25.3	37.5	—	23.1	35.4		
2500 cfm		EA (wb)	58	TC	64.0	64.0	72.5	60.4	60.4	68.5	56.6	56.6	64.3	52.0	52.0	59.1	47.5	47.5	54.1
				SHC	55.5	64.0	72.5	52.3	60.4	68.5	48.9	56.6	64.3	44.8	52.0	59.1	40.8	47.5	54.1
	62		TC	64.1	64.1	75.5	60.5	60.5	71.3	56.7	56.7	67.0	52.0	52.0	61.6	47.5	47.5	56.4	
			SHC	52.7	64.1	75.5	49.6	60.5	71.3	46.4	56.7	67.0	42.4	52.0	61.6	38.6	47.5	56.4	
	67		TC	68.5	68.5	70.0	63.6	63.6	67.7	58.9	58.9	65.6	53.3	53.3	63.2	47.8	47.8	60.4	
			SHC	43.1	56.5	70.0	40.9	54.3	67.7	38.9	52.3	65.6	36.5	49.8	63.2	34.0	47.2	60.4	
	72	TC	76.1	76.1	76.1	71.5	71.5	71.5	66.5	66.5	66.5	61.1	61.1	61.1	54.7	54.7	54.7		
		SHC	29.5	42.9	56.3	27.6	41.1	54.6	25.5	39.0	52.5	23.4	36.9	50.4	20.9	34.4	47.9		
	76	TC	—	81.1	81.1	—	77.0	77.0	—	72.3	72.3	—	67.2	67.2	—	61.7	61.7		
		SHC	—	31.5	44.8	—	29.8	43.3	—	28.0	41.5	—	26.0	39.5	—	23.9	37.5		

NOTE(S):

a. See minimum-maximum airflow ratings on page 7.

LEGEND

—	Do Not Operate
cfm	Cubic Feet Per Minute (Supply Air)
EA (db)	Entering Air Temperature (dry bulb)
EA (wb)	Entering Air Temperature (wet bulb)
SHC	Sensible Heat Capacity (1000 Btuh) Gross
TC	Total Capacity (1000 Btuh) Gross

50GCQ*06 Low Stage Cooling Capacities^a

50GCQ*06			AMBIENT TEMPERATURE (°F)																
			85			95			105			115			125				
			EA (db)			EA (db)			EA (db)			EA (db)			EA (db)				
			75	80	85	75	80	85	75	80	85	75	80	85	75	80	85		
1250 cfm	EA (wb)	58	TC	38.3	38.3	43.4	35.2	35.2	40.0	31.8	31.8	36.2	28.2	28.2	32.1	24.2	24.2	27.7	
			SHC	33.2	38.3	43.4	30.4	35.2	40.0	27.4	31.8	36.2	24.2	28.2	32.1	20.7	24.2	27.7	
		62	TC	38.6	38.6	45.0	35.3	35.3	41.6	31.9	31.9	37.8	28.2	28.2	33.5	24.2	24.2	28.9	
			SHC	31.5	38.2	45.0	28.9	35.3	41.6	26.0	31.9	37.8	22.9	28.2	33.5	19.5	24.2	28.9	
		67	TC	44.2	44.2	44.2	39.9	39.9	39.9	35.1	35.1	35.1	30.1	30.1	32.9	24.8	24.8	30.5	
			SHC	25.7	32.5	39.3	23.7	30.5	37.3	21.5	28.3	35.1	19.3	26.1	32.9	17.0	23.7	30.5	
	72	TC	50.0	50.0	50.0	46.0	46.0	46.0	41.4	41.4	41.4	35.9	35.9	35.9	30.1	30.1	30.1		
		SHC	19.6	26.4	33.2	17.8	24.6	31.4	15.8	22.6	29.4	13.5	20.3	27.1	11.2	18.0	24.8		
	76	TC	—	54.9	54.9	—	51.2	51.2	—	46.4	46.4	—	41.3	41.3	—	35.3	35.3		
		SHC	—	21.3	28.2	—	19.7	26.6	—	17.8	24.6	—	15.7	22.6	—	13.5	20.3		
	1500 cfm	EA (wb)	58	TC	41.7	41.7	47.2	38.2	38.2	43.3	34.5	34.5	39.3	30.6	30.6	34.9	26.3	26.3	30.1
				SHC	36.2	41.7	47.2	33.1	38.2	43.3	29.8	34.5	39.3	26.3	30.6	34.9	22.6	26.3	30.1
62			TC	41.7	41.7	49.1	38.3	38.3	45.1	34.6	34.6	40.9	30.6	30.6	36.3	26.4	26.4	31.4	
			SHC	34.4	41.7	49.1	31.4	38.3	45.1	28.3	34.6	40.9	24.9	30.6	36.3	21.3	26.4	31.4	
67			TC	46.0	46.0	46.0	41.7	41.7	42.5	36.6	36.6	40.2	31.4	31.4	37.8	26.4	26.4	34.0	
			SHC	28.2	36.3	44.5	26.2	34.3	42.5	24.0	32.1	40.2	21.7	29.8	37.8	18.9	26.4	34.0	
72		TC	52.0	52.0	52.0	47.9	47.9	47.9	43.1	43.1	43.1	37.4	37.4	37.4	31.3	31.3	31.3		
		SHC	20.7	28.9	37.0	18.9	27.0	35.2	16.9	25.0	33.2	14.6	22.7	30.9	12.3	20.4	28.5		
76		TC	—	56.6	56.6	—	53.0	53.0	—	48.2	48.2	—	42.9	42.9	—	36.8	36.8		
		SHC	—	22.5	30.7	—	21.0	29.3	—	19.1	27.2	—	17.0	25.2	—	14.8	22.9		
1750 cfm		EA (wb)	58	TC	44.3	44.3	50.1	40.8	40.8	46.2	36.8	36.8	41.8	32.7	32.7	37.2	28.1	28.1	32.1
				SHC	38.5	44.3	50.1	35.4	40.8	46.2	31.8	36.8	41.8	28.1	32.7	37.2	24.1	28.1	32.1
	62		TC	44.4	44.4	52.2	40.9	40.9	48.1	36.9	36.9	43.5	32.7	32.7	38.7	28.2	28.2	33.5	
			SHC	36.6	44.4	52.2	33.6	40.9	48.1	30.2	36.9	43.5	26.7	32.7	38.7	22.8	28.2	33.5	
	67		TC	47.2	47.2	49.4	43.0	43.0	47.4	37.8	37.8	45.1	33.3	33.3	40.7	28.2	28.2	36.2	
			SHC	30.5	40.0	49.4	28.6	38.0	47.4	26.3	35.7	45.1	23.3	32.0	40.7	20.2	28.2	36.2	
	72	TC	53.3	53.3	53.3	49.2	49.2	49.2	44.2	44.2	44.2	38.6	38.6	38.6	32.2	32.2	32.2		
		SHC	21.6	31.1	40.6	19.9	29.4	38.9	17.8	27.3	36.8	15.6	25.1	34.5	13.2	22.7	32.1		
	76	TC	—	57.7	57.7	—	54.2	54.2	—	49.6	49.6	—	44.0	44.0	—	37.9	37.9		
		SHC	—	23.6	33.0	—	22.1	31.6	—	20.3	29.9	—	18.2	27.6	—	15.9	25.4		
	2000 cfm	EA (wb)	58	TC	46.5	46.5	52.6	43.0	43.0	48.7	38.8	38.8	44.1	34.4	34.4	39.1	29.7	29.7	33.8
				SHC	40.4	46.5	52.6	37.3	43.0	48.7	33.6	38.8	44.1	29.7	34.4	39.1	25.5	29.7	33.8
62			TC	46.5	46.5	54.7	43.0	43.0	50.6	38.9	38.9	45.9	34.5	34.5	40.8	29.7	29.7	35.3	
			SHC	38.4	46.5	54.7	35.4	43.0	50.6	31.9	38.9	45.9	28.1	34.5	40.8	24.1	29.7	35.3	
67			TC	48.2	48.2	54.2	44.0	44.0	52.1	39.3	39.3	48.8	34.5	34.5	44.0	29.8	29.8	38.1	
			SHC	32.8	43.5	54.2	30.8	41.5	52.1	28.3	38.5	48.8	25.0	34.5	44.0	21.4	29.8	38.1	
72		TC	54.3	54.3	54.3	50.2	50.2	50.2	45.1	45.1	45.1	39.4	39.4	39.4	32.9	32.9	35.6		
		SHC	22.5	33.2	43.9	20.8	31.6	42.4	18.7	29.5	40.2	16.5	27.3	38.0	14.1	24.8	35.6		
76		TC	—	58.5	58.5	—	55.0	55.0	—	50.6	50.6	—	44.8	44.8	—	38.7	38.7		
		SHC	—	24.4	35.0	—	23.1	33.8	—	21.4	32.3	—	19.2	30.0	—	17.0	27.8		
2250 cfm		EA (wb)	58	TC	48.2	48.2	54.5	44.7	44.7	50.6	40.6	40.6	46.1	35.9	35.9	40.8	31.0	31.0	35.4
				SHC	42.0	48.2	54.5	38.8	44.7	50.6	35.2	40.6	46.1	31.0	35.9	40.8	26.7	31.0	35.4
	62		TC	48.3	48.3	56.7	44.7	44.7	52.6	40.7	40.7	48.0	35.9	35.9	42.5	31.0	31.0	36.8	
			SHC	39.9	48.3	56.7	36.9	44.7	52.6	33.4	40.7	48.0	29.4	35.9	42.5	25.2	31.0	36.8	
	67		TC	49.2	49.2	58.7	45.3	45.3	55.1	40.8	40.8	51.7	36.0	36.0	45.9	31.1	31.1	39.8	
			SHC	34.9	46.8	58.7	32.4	43.8	55.1	29.8	40.8	51.7	26.2	36.0	45.9	22.4	31.1	39.8	
	72	TC	55.0	55.0	55.0	51.0	51.0	51.0	45.7	45.7	45.7	40.1	40.1	41.4	33.5	33.5	39.0		
		SHC	23.2	35.2	47.1	21.6	33.6	45.7	19.5	31.6	43.6	17.4	29.4	41.4	15.0	27.0	39.0		
	76	TC	—	59.0	59.0	—	55.6	55.6	—	51.4	51.4	—	45.4	45.4	—	39.3	39.3		
		SHC	—	25.1	36.9	—	23.9	35.8	—	22.3	34.4	—	20.1	32.2	—	17.9	30.0		

NOTE(S):

a. See minimum-maximum airflow ratings on page 7.

LEGEND

—	Do Not Operate
cfm	Cubic Feet Per Minute (Supply Air)
EA (db)	Entering Air Temperature (dry bulb)
EA (wb)	Entering Air Temperature (wet bulb)
SHC	Sensible Heat Capacity (1000 Btuh) Gross
TC	Total Capacity (1000 Btuh) Gross

50GCQ*04 Heating Capacities

RETURN AIR (°F db)	CFM (Standard Air)		TEMPERATURE AIR ENTERING OUTDOOR COIL (°F db at 70% rh)								
			-10	0	10	17	30	40	47	50	60
55	900	Capacity	9.1	12.7	16.6	19.9	25.7	30.1	34.2	35.5	40.6
		Int. Cap.	8.4	11.7	15.3	18.1	22.5	30.1	34.2	35.5	40.6
	1200	Capacity	9.6	13.4	17.5	20.7	26.4	31.4	35.4	36.7	41.5
		Int. Cap.	8.9	12.3	16.1	18.9	23.1	31.4	35.4	36.7	41.5
	1500	Capacity	10.2	14.0	18.2	21.4	27.2	32.4	36.0	37.1	41.4
		Int. Cap.	9.4	12.9	16.7	19.5	23.9	32.4	36.0	37.1	41.4
70	900	Capacity	7.0	10.7	14.6	17.5	23.8	28.3	31.9	33.1	38.5
		Int. Cap.	6.5	9.8	13.4	16.0	20.8	28.3	31.9	33.1	38.5
	1200	Capacity	7.6	11.4	15.4	18.5	24.8	29.6	33.4 ^a	34.6	39.6
		Int. Cap.	7.0	10.4	14.1	16.9	21.8	29.6	33.4 ^a	34.6	39.6
	1500	Capacity	8.1	11.9	16.1	19.3	25.5	30.2	34.1	35.4	39.9
		Int. Cap.	7.5	11.0	14.8	17.6	22.3	30.2	34.1	35.4	39.9
80	900	Capacity	5.5	9.2	13.1	16.0	22.1	27.0	30.3	31.8	37.0
		Int. Cap.	5.1	8.4	12.0	14.6	19.4	27.0	30.3	31.8	37.0
	1200	Capacity	6.1	9.9	13.9	17.0	23.4	28.1	31.8	33.1	38.2
		Int. Cap.	5.6	9.1	12.8	15.5	20.5	28.1	31.8	33.1	38.2
	1500	Capacity	6.6	10.4	14.6	17.7	24.5	29.1	32.8	34.0	38.7
		Int. Cap.	6.1	9.6	13.4	16.2	21.5	29.1	32.8	34.0	38.7

NOTE(S):

a. Indicates standard rating point.

LEGEND

- Capacity** — Instantaneous Capacity (1000 Btuh) — includes indoor fan motor heat at AHRI static conditions
- Int. Cap.** — Integrated Capacity = instantaneous capacity minus the effects of frost on the OD coil and the heat required to defrost it
- rh** — Relative Humidity
- db** — Dry Bulb

50GCQ*05 Heating Capacities

RETURN AIR (°F db)	CFM (Standard Air)		TEMPERATURE AIR ENTERING OUTDOOR COIL (°F db at 70% rh)								
			-10	0	10	17	30	40	47	50	60
55	1200	Capacity	11.0	16.5	22.3	26.9	34.8	41.5	47.2	48.9	55.7
		Int. Cap.	10.2	15.1	20.4	24.5	30.5	41.5	47.2	48.9	55.7
	1600	Capacity	11.7	17.4	23.4	28.1	36.3	43.5	48.8	50.4	56.7
		Int. Cap.	10.8	16.0	21.5	25.6	31.8	43.5	48.8	50.4	56.7
	2000	Capacity	12.4	18.2	24.4	29.2	37.5	44.6	49.3	50.6	56.4
		Int. Cap.	11.5	16.7	22.4	26.6	32.9	44.6	49.3	50.6	56.4
70	1200	Capacity	8.4	13.7	19.4	23.6	32.6	38.8	44.0	45.7	52.9
		Int. Cap.	7.7	12.6	17.8	21.5	28.6	38.8	44.0	45.7	52.7
	1600	Capacity	9.1	14.7	20.6	25.1	33.8	40.3	46.0 ^a	47.7	54.2
		Int. Cap.	8.4	13.5	18.9	22.9	29.6	40.3	46.0 ^a	47.7	54.2
	2000	Capacity	9.9	15.6	21.6	26.2	35.0	41.8	46.9	48.6	54.5
		Int. Cap.	9.1	14.3	19.8	23.9	30.7	41.8	46.9	48.6	54.5
80	1200	Capacity	6.4	11.7	17.3	21.5	30.6	36.9	41.8	44.0	51.0
		Int. Cap.	5.9	10.8	15.9	19.6	26.8	36.9	41.8	44.0	51.0
	1600	Capacity	7.1	12.7	18.5	23.0	32.4	38.7	43.9	45.7	52.5
		Int. Cap.	6.6	11.7	17.0	20.9	28.4	38.7	43.9	45.7	52.5
	2000	Capacity	7.9	13.6	19.6	24.0	33.2	40.0	45.2	47.0	53.0
		Int. Cap.	7.3	12.5	18.0	21.9	29.1	40.0	45.2	47.0	53.0

NOTE(S):

a. Indicates standard rating point.

LEGEND

- Capacity** — Instantaneous Capacity (1000 Btuh) — includes indoor fan motor heat at AHRI static conditions
- Int. Cap.** — Integrated Capacity = instantaneous capacity minus the effects of frost on the OD coil and the heat required to defrost it
- rh** — Relative Humidity
- db** — Dry Bulb

50GCQ*06 Heating Capacities

RETURN AIR (°F db)	CFM (Standard Air)		TEMPERATURE AIR ENTERING OUTDOOR COIL (°F db at 70% rh)								
			-10	0	10	17	30	40	47	50	60
55	1500	Capacity	21.3	25.9	30.8	34.8	42.7	49.3	54.2	55.6	61.9
		Int. Cap.	19.7	23.8	28.3	31.7	37.4	49.3	54.2	55.6	61.9
	2000	Capacity	22.0	26.8	31.6	35.9	43.7	50.1	54.6	55.9	61.4
		Int. Cap.	20.4	24.7	29.0	32.7	38.3	50.1	54.6	55.9	61.4
	2500	Capacity	23.0	27.8	32.8	36.9	44.7	50.7	54.7	55.8	60.4
		Int. Cap.	21.3	25.6	30.1	33.6	39.2	50.7	54.7	55.8	60.4
70	1500	Capacity	19.8	24.6	29.8	33.2	41.5	47.8	53.0	54.4	60.9
		Int. Cap.	18.3	22.6	27.3	30.3	36.4	47.8	53.0	54.4	60.9
	2000	Capacity	20.6	25.4	30.6	34.2	42.6	49.0	53.8 ^a	55.2	61.0
		Int. Cap.	19.1	23.4	28.1	31.2	37.3	49.0	53.8 ^a	55.2	61.0
	2500	Capacity	21.7	26.6	31.8	35.5	43.7	50.0	54.4	55.7	60.7
		Int. Cap.	20.0	24.5	29.1	32.3	38.3	50.0	54.4	55.7	60.7
80	1500	Capacity	18.6	23.5	28.5	32.5	40.1	47.0	52.0	53.5	60.0
		Int. Cap.	17.2	21.6	26.2	29.6	35.1	47.0	52.0	53.5	60.0
	2000	Capacity	19.5	24.4	29.6	33.5	41.7	48.1	53.1	54.5	60.5
		Int. Cap.	18.0	22.5	27.2	30.5	36.5	48.1	53.1	54.5	60.5
	2500	Capacity	20.6	25.6	30.8	34.6	43.0	49.4	54.0	55.3	60.6
		Int. Cap.	19.1	23.5	28.3	31.6	37.7	49.4	54.0	55.3	60.6

NOTE(S):

a. Indicates standard rating point.

LEGEND

- Capacity** — Instantaneous Capacity (1000 Btuh) — includes indoor fan motor heat at AHRI static conditions
- Int. Cap.** — Integrated Capacity = instantaneous capacity minus the effects of frost on the OD coil and the heat required to defrost it
- rh** — Relative Humidity
- db** — Dry Bulb

Pressure Drops for Electric Heating Units

Pressure Drop for Electric Heat 3 Ton Units — 1 Stage Heat

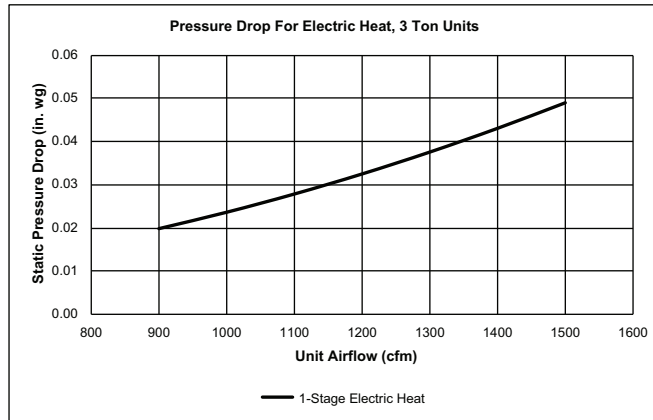

Pressure Drop for Electric Heat 4 and 5 Ton Units — 1 and 2 Stage Heat

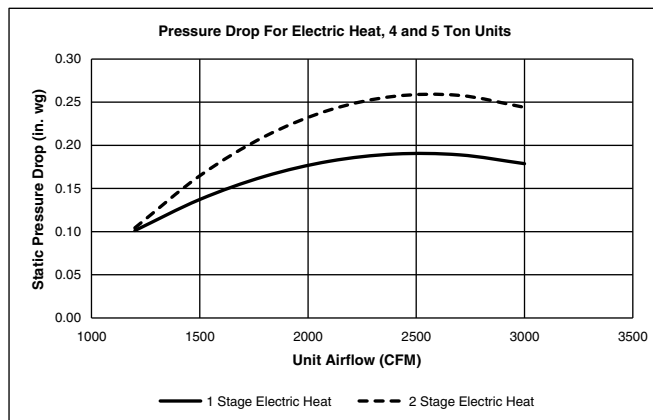

Field-Installed Accessory Electric Heater Data

50GCQ UNIT SIZE	VOLTAGE	HEATER MODEL NUMBER ^a	NUMBER OF STAGES		
04	208/230	CRHEATER323A00	1		
		CRHEATER324A00	1		
		CRHEATER325A00	1		
		CRHEATER326A00	1		
		CRHEATER327A00	2		
		CRHEATER328A00	1		
	460	CRHEATER333A00	1		
		CRHEATER334A00	1		
		CRHEATER335A00	1		
		CRHEATER336A00	1		
	575	CRHEATER339A00	1		
		CRHEATER340A00	1		
05	208/230	CRHEATER323A00	1		
		CRHEATER324A00	1		
		CRHEATER325A00	1		
		CRHEATER326A00	1		
		CRHEATER327A00	2		
		CRHEATER328A00	1		
		CRHEATER329A00	2		
		CRHEATER330A00 ^b	2		
		CRHEATER331A00 ^c	2		
	460	CRHEATER333A00	1		
		CRHEATER335A00	1		
		CRHEATER336A00	1		
	575	CRHEATER337A00	2		
		CRHEATER339A00	1		
		CRHEATER340A00	1		
		06	208/230	CRHEATER324A00	1
				CRHEATER325A00	1
				CRHEATER326A00	1
CRHEATER327A00	2				
CRHEATER328A00	1				
CRHEATER329A00	2				
460	CRHEATER331A00		2		
	CRHEATER332A00		2		
	CRHEATER333A00		1		
575	CRHEATER335A00	1			
	CRHEATER336A00	1			
	CRHEATER337A00	2			
575	CRHEATER338A00	2			
	CRHEATER340A00	1			
575	CRHEATER341A00	2			

NOTE(S):

- a. Check heater nameplate for model number.
- b. Do not use with size 05 horizontal supply duct configuration units.
- c. Do not use with size 05 vertical supply duct configuration units.

Use of CRHEATER330A00 for 50GCQ Units (With or Without Non-Fused Disconnect)

DUCT CONFIGURATION	50GCQ UNIT SIZE		
	04	05	06
Vertical Supply	Not available	Available	Not available
Horizontal Supply	Not available	Not available	Not available

Use of CRHEATER331A00 for 50GCQ Units (With or Without Non-Fused Disconnect)

DUCT CONFIGURATION	50GCQ UNIT SIZE		
	04	05	06
Vertical Supply	Not available	Not available	Available
Horizontal Supply	Not available	Available	Available

Economizer Barometric Relief and Static Pressure, 3 to 5 Ton Units

Horizontal Economizer Barometric Relief

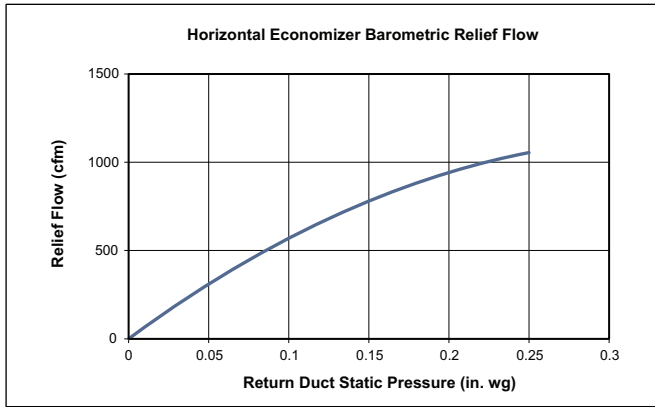

Vertical Economizer Barometric Relief

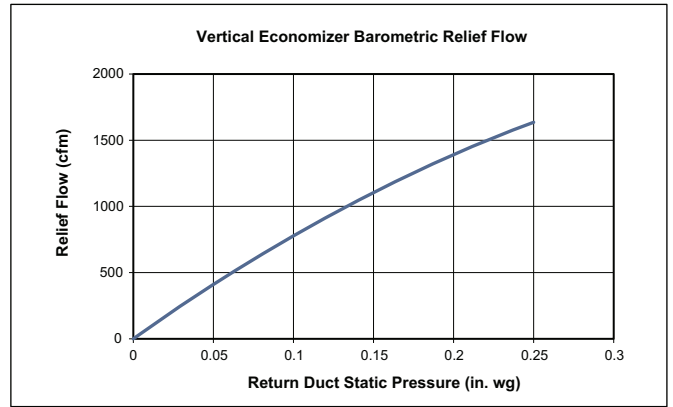

Horizontal Economizer Damper Leakage

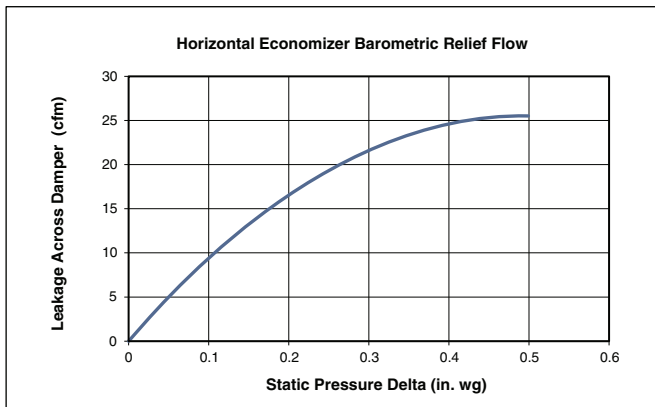

Vertical Economizer Damper Leakage

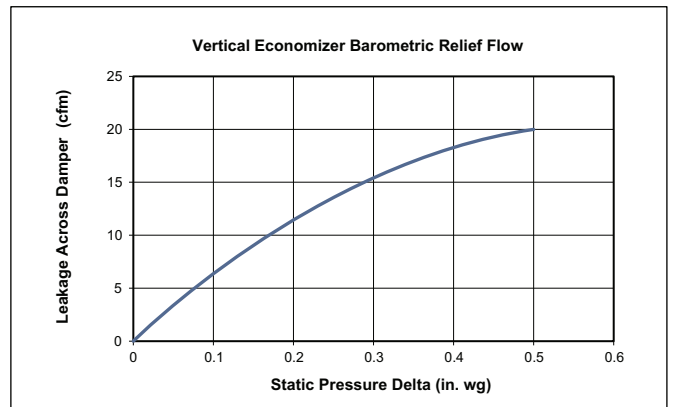

MERV-13 filters pressure drop

NOTE: For factory-installed MERV-13 filters, no additional pressure drop adjustments are necessary. The standard fan tables accommodate usage.

General Fan Performance Notes

1. Interpolation is permissible. Do not extrapolate.
2. External static pressure is the static pressure difference between the return duct and the supply duct plus the static pressure caused by any FIOPs or accessories.
3. Tabular data accounts for pressure loss due to clean filters, unit casing, and wet coils.
4. Factory options and accessories may effect static pressure losses. Selection software is available, through your salesperson, to help you select the best motor/drive combination for your application.
5. The fan performance tables offer motor/drive recommendations. In cases when two motor/drive combinations would work, Carrier recommends the lower horsepower option.
6. For information on the electrical properties of Carrier motors, please see the Electrical Data section of the Product Data book for this model and size.
7. For more information on the performance limits of Carrier motors, see the Application Data section of the Product Data book for this model and size.
8. The EPACT (Energy Policy Act of 1992) regulates energy requirements for specific types of indoor fan motors. Motors regulated by EPACT include any general purpose, T-frame (three-digit, 143 and larger), single-speed, foot mounted, polyphase, squirrel cage induction motors of NEMA (National Electrical Manufacturers Association) design A and B, manufactured for use in the United States. Ranging from 1 to 200 Hp, these continuous-duty motors operate on 230 and 460 volt, 60 Hz power. If a motor does not fit into these specifications, the motor does not have to be replaced by an EPACT compliant energy-efficient motor. Variable-speed motors are exempt from EPACT compliance requirements.

50GCQT04 Single Phase — 3 Ton Vertical Supply (rpm - bhp)

CFM	AVAILABLE EXTERNAL STATIC PRESSURE (in. wg)									
	0.2		0.4		0.6		0.8		1.0	
	rpm	bhp	rpm	bhp	rpm	bhp	rpm	bhp	rpm	bhp
900	1059	0.08	1325	0.16	1541	0.25	1718	0.35	1870	0.46
975	1102	0.09	1356	0.17	1572	0.27	1751	0.37	1906	0.48
1050	1149	0.11	1388	0.19	1602	0.29	1783	0.39	1940	0.51
1125	1198	0.12	1422	0.20	1632	0.30	1814	0.42	1973	0.53
1200	1250	0.14	1459	0.22	1662	0.32	1844	0.44	2005	0.56
1275	1303	0.15	1499	0.23	1695	0.34	1874	0.46	2035	0.59
1350	1357	0.17	1542	0.26	1728	0.36	1905	0.48	2065	0.61
1425	1413	0.20	1587	0.28	1764	0.38	1936	0.51	2095	0.64
1500	1469	0.22	1635	0.30	1803	0.41	1969	0.53	2126	0.67

CFM	AVAILABLE EXTERNAL STATIC PRESSURE (in. wg)									
	1.2		1.4		1.6		1.8		2.0	
	rpm	bhp	rpm	bhp	rpm	bhp	rpm	bhp	rpm	bhp
900	2006	0.56	2129	0.67	2244	0.79	2352	0.91	2453	1.03
975	2043	0.59	2168	0.71	2283	0.83	2391	0.95	—	—
1050	2079	0.63	2205	0.75	2322	0.87	2430	1.00	—	—
1125	2114	0.66	2242	0.78	2359	0.91	2468	1.05	—	—
1200	2147	0.69	2277	0.82	2395	0.96	—	—	—	—
1275	2180	0.72	2310	0.86	2430	1.00	—	—	—	—
1350	2211	0.75	2343	0.90	2464	1.04	—	—	—	—
1425	2241	0.78	2374	0.93	—	—	—	—	—	—
1500	2271	0.82	2405	0.97	—	—	—	—	—	—

Standard Static 1059-1890 rpm, 0.44 Max bhp

Medium Static 1059-2190 rpm, 0.71 Max bhp

High Static 1059-2490 rpm, 1.07 Max bhp

50GCQT04 Single Phase — Standard Static — 3 Ton Vertical Supply (rpm - vdc)

CFM	AVAILABLE EXTERNAL STATIC PRESSURE (in. wg)									
	0.2		0.4		0.6		0.8		1.0	
	rpm	vdc	rpm	vdc	rpm	vdc	rpm	vdc	rpm	vdc
900	1060	5.6	1325	7.0	1541	8.2	1718	9.1	1871	9.9
975	1103	5.8	1355	7.2	1572	8.3	1752	9.3	—	—
1050	1150	6.1	1387	7.3	1602	8.5	1784	9.4	—	—
1125	1198	6.3	1422	7.5	1632	8.6	1815	9.6	—	—
1200	1249	6.6	1459	7.7	1662	8.8	1845	9.8	—	—
1275	1303	6.9	1499	7.9	1694	9.0	1874	9.9	—	—
1350	1357	7.2	1542	8.2	1728	9.1	—	—	—	—
1425	1413	7.5	1587	8.4	1765	9.3	—	—	—	—
1500	1469	7.8	1635	8.7	1803	9.5	—	—	—	—

CFM	AVAILABLE EXTERNAL STATIC PRESSURE (in. wg)									
	1.2		1.4		1.6		1.8		2.0	
	rpm	vdc	rpm	vdc	rpm	vdc	rpm	vdc	rpm	vdc
900	—	—	—	—	—	—	—	—	—	—
975	—	—	—	—	—	—	—	—	—	—
1050	—	—	—	—	—	—	—	—	—	—
1125	—	—	—	—	—	—	—	—	—	—
1200	—	—	—	—	—	—	—	—	—	—
1275	—	—	—	—	—	—	—	—	—	—
1350	—	—	—	—	—	—	—	—	—	—
1425	—	—	—	—	—	—	—	—	—	—
1500	—	—	—	—	—	—	—	—	—	—

Standard Static 1060-1890 rpm

50GCQT04 Single Phase — Medium Static — 3 Ton Vertical Supply (rpm - vdc)

CFM	AVAILABLE EXTERNAL STATIC PRESSURE (in. wg)									
	0.2		0.4		0.6		0.8		1.0	
	rpm	vdc	rpm	vdc	rpm	vdc	rpm	vdc	rpm	vdc
900	1060	4.8	1325	6.1	1541	7.0	1718	7.8	1871	8.5
975	1103	5.0	1355	6.2	1572	7.2	1752	8.0	1906	8.7
1050	1150	5.3	1387	6.3	1602	7.3	1784	8.1	1941	8.9
1125	1198	5.5	1422	6.5	1632	7.5	1815	8.3	1974	9.0
1200	1249	5.7	1459	6.7	1662	7.6	1845	8.4	2005	9.2
1275	1303	5.9	1499	6.8	1694	7.7	1874	8.6	2036	9.3
1350	1357	6.2	1542	7.0	1728	7.9	1905	8.7	2066	9.4
1425	1413	6.5	1587	7.2	1765	8.1	1936	8.8	2095	9.6
1500	1469	6.7	1635	7.5	1803	8.2	1969	9.0	2126	9.7

CFM	AVAILABLE EXTERNAL STATIC PRESSURE (in. wg)									
	1.2		1.4		1.6		1.8		2.0	
	rpm	vdc	rpm	vdc	rpm	vdc	rpm	vdc	rpm	vdc
900	2006	9.2	2130	9.7	—	—	—	—	—	—
975	2044	9.3	2168	9.9	—	—	—	—	—	—
1050	2080	9.5	—	—	—	—	—	—	—	—
1125	2115	9.7	—	—	—	—	—	—	—	—
1200	2148	9.8	—	—	—	—	—	—	—	—
1275	2180	10.0	—	—	—	—	—	—	—	—
1350	—	—	—	—	—	—	—	—	—	—
1425	—	—	—	—	—	—	—	—	—	—
1500	—	—	—	—	—	—	—	—	—	—

Medium Static 1060-2190 rpm

50GCQT04 Single Phase — High Static — 3 Ton Vertical Supply (rpm - vdc)

CFM	AVAILABLE EXTERNAL STATIC PRESSURE (in. wg)									
	0.2		0.4		0.6		0.8		1.0	
	rpm	vdc	rpm	vdc	rpm	vdc	rpm	vdc	rpm	vdc
900	1060	4.3	1325	5.3	1541	6.2	1718	6.9	1871	7.5
975	1103	4.4	1355	5.4	1572	6.3	1752	7.0	1906	7.7
1050	1150	4.6	1387	5.6	1602	6.4	1784	7.2	1941	7.8
1125	1198	4.8	1422	5.7	1632	6.6	1815	7.3	1974	7.9
1200	1249	5.0	1459	5.9	1662	6.7	1845	7.4	2005	8.1
1275	1303	5.2	1499	6.0	1694	6.8	1874	7.5	2036	8.2
1350	1357	5.4	1542	6.2	1728	6.9	1905	7.7	2066	8.3
1425	1413	5.7	1587	6.4	1765	7.1	1936	7.8	2095	8.4
1500	1469	5.9	1635	6.6	1803	7.2	1969	7.9	2126	8.5

CFM	AVAILABLE EXTERNAL STATIC PRESSURE (in. wg)									
	1.2		1.4		1.6		1.8		2.0	
	rpm	vdc	rpm	vdc	rpm	vdc	rpm	vdc	rpm	vdc
900	2006	8.1	2130	8.6	2244	9.0	2352	9.4	2453	9.9
975	2044	8.2	2168	8.7	2283	9.2	2391	9.6	—	—
1050	2080	8.4	2206	8.9	2322	9.3	2430	9.8	—	—
1125	2115	8.5	2242	9.0	2359	9.5	2468	9.9	—	—
1200	2148	8.6	2277	9.1	2396	9.6	—	—	—	—
1275	2180	8.8	2311	9.3	2431	9.8	—	—	—	—
1350	2211	8.9	2343	9.4	2465	9.9	—	—	—	—
1425	2241	9.0	2375	9.5	—	—	—	—	—	—
1500	2271	9.1	2405	9.7	—	—	—	—	—	—

High Static 1060-2490 rpm

50GCQJ04 Three Phase — 3 Ton Vertical Supply (rpm - bhp)

CFM	AVAILABLE EXTERNAL STATIC PRESSURE (in. wg)									
	0.2		0.4		0.6		0.8		1.0	
	rpm	bhp	rpm	bhp	rpm	bhp	rpm	bhp	rpm	bhp
900	1058	0.08	1325	0.16	1541	0.25	1718	0.35	1870	0.46
975	1102	0.09	1356	0.17	1572	0.27	1751	0.37	1906	0.48
1050	1149	0.11	1388	0.19	1602	0.29	1783	0.39	1940	0.51
1125	1198	0.12	1422	0.20	1632	0.30	1814	0.42	1973	0.53
1200	1250	0.14	1459	0.22	1662	0.32	1844	0.44	2005	0.56
1275	1303	0.15	1499	0.23	1695	0.34	1874	0.46	2035	0.59
1350	1357	0.17	1542	0.26	1728	0.36	1905	0.48	2065	0.61
1425	1413	0.20	1587	0.28	1764	0.38	1936	0.51	2095	0.64
1500	1469	0.22	1635	0.30	1803	0.41	1969	0.53	2126	0.67

CFM	AVAILABLE EXTERNAL STATIC PRESSURE (in. wg)									
	1.2		1.4		1.6		1.8		2.0	
	rpm	bhp	rpm	bhp	rpm	bhp	rpm	bhp	rpm	bhp
900	2006	0.56	2129	0.67	2244	0.79	2352	0.91	2453	1.03
975	2043	0.59	2168	0.71	2283	0.83	2391	0.95	—	—
1050	2079	0.63	2205	0.75	2322	0.87	2430	1.00	—	—
1125	2114	0.66	2242	0.78	2359	0.91	2468	1.05	—	—
1200	2147	0.69	2277	0.82	2395	0.96	—	—	—	—
1275	2180	0.72	2310	0.86	2430	1.00	—	—	—	—
1350	2211	0.75	2343	0.90	2464	1.04	—	—	—	—
1425	2241	0.78	2374	0.93	—	—	—	—	—	—
1500	2271	0.82	2405	0.97	—	—	—	—	—	—

Standard Static 1058-1890 rpm, 0.44 Max bhp

Medium Static 1058-2190 rpm, 0.71 Max bhp

High Static 1058-2490 rpm, 1.07 Max bhp

50GCQJ04 Three Phase — Standard Static — 3 Ton Vertical Supply (rpm - vdc)

CFM	AVAILABLE EXTERNAL STATIC PRESSURE (in. wg)									
	0.2		0.4		0.6		0.8		1.0	
	rpm	vdc	rpm	vdc	rpm	vdc	rpm	vdc	rpm	vdc
900	1060	5.6	1325	7.0	1541	8.2	1718	9.1	1871	9.9
975	1103	5.8	1355	7.2	1572	8.3	1752	9.3	—	—
1050	1150	6.1	1387	7.3	1602	8.5	1784	9.4	—	—
1125	1198	6.3	1422	7.5	1632	8.6	1815	9.6	—	—
1200	1249	6.6	1460	7.7	1662	8.8	1845	9.8	—	—
1275	1303	6.9	1499	7.9	1694	9.0	1874	9.9	—	—
1350	1357	7.2	1542	8.2	1728	9.1	—	—	—	—
1425	1413	7.5	1587	8.4	1765	9.3	—	—	—	—
1500	1469	7.8	1635	8.7	1803	9.5	—	—	—	—

CFM	AVAILABLE EXTERNAL STATIC PRESSURE (in. wg)									
	1.2		1.4		1.6		1.8		2.0	
	rpm	Vdc	rpm	Vdc	rpm	Vdc	rpm	Vdc	rpm	Vdc
900	—	—	—	—	—	—	—	—	—	—
975	—	—	—	—	—	—	—	—	—	—
1050	—	—	—	—	—	—	—	—	—	—
1125	—	—	—	—	—	—	—	—	—	—
1200	—	—	—	—	—	—	—	—	—	—
1275	—	—	—	—	—	—	—	—	—	—
1350	—	—	—	—	—	—	—	—	—	—
1425	—	—	—	—	—	—	—	—	—	—
1500	—	—	—	—	—	—	—	—	—	—

Standard Static 1060-1890 rpm

50GCQJ04 Three Phase — Medium Static — 3 Ton Vertical Supply (rpm - vdc)

CFM	AVAILABLE EXTERNAL STATIC PRESSURE (in. wg)									
	0.2		0.4		0.6		0.8		1.0	
	rpm	vdc	rpm	vdc	rpm	vdc	rpm	vdc	rpm	vdc
900	1060	4.8	1325	6.1	1541	7.0	1718	7.8	1871	8.5
975	1103	5.0	1355	6.2	1572	7.2	1752	8.0	1906	8.7
1050	1150	5.3	1387	6.3	1602	7.3	1784	8.1	1941	8.9
1125	1198	5.5	1422	6.5	1632	7.5	1815	8.3	1974	9.0
1200	1249	5.7	1460	6.7	1662	7.6	1845	8.4	2005	9.2
1275	1303	5.9	1499	6.8	1694	7.7	1874	8.6	2036	9.3
1350	1357	6.2	1542	7.0	1728	7.9	1905	8.7	2066	9.4
1425	1413	6.5	1587	7.2	1765	8.1	1936	8.8	2095	9.6
1500	1469	6.7	1635	7.5	1803	8.2	1969	9.0	2126	9.7

CFM	AVAILABLE EXTERNAL STATIC PRESSURE (in. wg)									
	1.2		1.4		1.6		1.8		2.0	
	rpm	Vdc	rpm	Vdc	rpm	Vdc	rpm	Vdc	rpm	Vdc
900	2006	9.2	2130	9.7	—	—	—	—	—	—
975	2044	9.3	2169	9.9	—	—	—	—	—	—
1050	2080	9.5	—	—	—	—	—	—	—	—
1125	2115	9.7	—	—	—	—	—	—	—	—
1200	2148	9.8	—	—	—	—	—	—	—	—
1275	2180	10.0	—	—	—	—	—	—	—	—
1350	—	—	—	—	—	—	—	—	—	—
1425	—	—	—	—	—	—	—	—	—	—
1500	—	—	—	—	—	—	—	—	—	—

Medium Static 1060-2190 rpm

50GCQJ04 Three Phase — High Static — 3 Ton Vertical Supply (rpm - vdc)

CFM	AVAILABLE EXTERNAL STATIC PRESSURE (in. wg)									
	0.2		0.4		0.6		0.8		1.0	
	rpm	vdc	rpm	vdc	rpm	vdc	rpm	vdc	rpm	vdc
900	1060	4.3	1325	5.3	1541	6.2	1718	6.9	1871	7.5
975	1103	4.4	1355	5.4	1572	6.3	1752	7.0	1906	7.7
1050	1150	4.6	1387	5.6	1602	6.4	1784	7.2	1941	7.8
1125	1198	4.8	1422	5.7	1632	6.6	1815	7.3	1974	7.9
1200	1249	5.0	1460	5.9	1662	6.7	1845	7.4	2005	8.1
1275	1303	5.2	1499	6.0	1694	6.8	1874	7.5	2036	8.2
1350	1357	5.4	1542	6.2	1728	6.9	1905	7.7	2066	8.3
1425	1413	5.7	1587	6.4	1765	7.1	1936	7.8	2095	8.4
1500	1469	5.9	1635	6.6	1803	7.2	1969	7.9	2126	8.5

CFM	AVAILABLE EXTERNAL STATIC PRESSURE (in. wg)									
	1.2		1.4		1.6		1.8		2.0	
	rpm	vdc	rpm	vdc	rpm	vdc	rpm	vdc	rpm	vdc
900	2006	8.1	2130	8.6	2245	9.0	2352	9.4	2454	9.9
975	2044	8.2	2169	8.7	2284	9.2	2391	9.6	—	—
1050	2080	8.4	2206	8.9	2322	9.3	2430	9.8	—	—
1125	2115	8.5	2242	9.0	2360	9.5	2469	9.9	—	—
1200	2148	8.6	2277	9.1	2396	9.6	—	—	—	—
1275	2180	8.8	2311	9.3	2431	9.8	—	—	—	—
1350	2211	8.9	2343	9.4	2465	9.9	—	—	—	—
1425	2241	9.0	2375	9.5	—	—	—	—	—	—
1500	2271	9.1	2405	9.7	—	—	—	—	—	—

High Static 1060-2490 rpm

50GCQT05 Single Phase — 4 Ton Vertical Supply (rpm - bhp)

CFM	AVAILABLE EXTERNAL STATIC PRESSURE (in. wg)									
	0.2		0.4		0.6		0.8		1.0	
	rpm	bhp	rpm	bhp	rpm	bhp	rpm	bhp	rpm	bhp
1200	1048	0.12	1251	0.21	1431	0.32	1590	0.43	1735	0.56
1300	1102	0.14	1293	0.23	1467	0.34	1622	0.46	1765	0.59
1400	1158	0.17	1337	0.26	1505	0.36	1657	0.49	1796	0.62
1500	1217	0.19	1383	0.28	1545	0.39	1693	0.52	1830	0.65
1600	1277	0.22	1432	0.31	1587	0.42	1731	0.55	1865	0.69
1700	1340	0.25	1483	0.34	1631	0.46	1771	0.59	1902	0.73
1800	1404	0.29	1536	0.38	1677	0.50	1812	0.63	1940	0.77
1900	1469	0.33	1592	0.42	1724	0.54	1855	0.67	1980	0.81
2000	1535	0.38	1649	0.47	1774	0.58	1900	0.72	2021	0.86

CFM	AVAILABLE EXTERNAL STATIC PRESSURE (in. wg)									
	1.2		1.4		1.6		1.8		2.0	
	rpm	bhp	rpm	bhp	rpm	bhp	rpm	bhp	rpm	bhp
1200	1869	0.70	1994	0.86	2111	1.02	2221	1.18	2324	1.35
1300	1897	0.73	2020	0.89	2136	1.05	2246	1.22	2350	1.39
1400	1926	0.76	2048	0.92	2162	1.08	2271	1.25	2375	1.43
1500	1957	0.80	2077	0.95	2190	1.12	2298	1.29	2400	1.47
1600	1990	0.84	2107	0.99	2219	1.16	2325	1.33	2427	1.52
1700	2024	0.88	2140	1.04	2250	1.20	2354	1.38	2455	1.56
1800	2060	0.92	2174	1.08	2282	1.25	2385	1.43	—	—
1900	2097	0.97	2209	1.13	2315	1.30	2417	1.48	—	—
2000	2136	1.02	2246	1.19	2350	1.36	2451	1.54	—	—

Standard Static 1048-1900 rpm, 0.72 Max bhp

Medium Static 1047-2170 rpm, 1.06 Max bhp

High Static 1047-2460 rpm, 1.53 Max bhp

50GCQT05 Single Phase — Standard Static — 4 Ton Vertical Supply (rpm - vdc)

CFM	AVAILABLE EXTERNAL STATIC PRESSURE (in. wg)									
	0.2		0.4		0.6		0.8		1.0	
	rpm	vdc	rpm	vdc	rpm	vdc	rpm	vdc	rpm	vdc
1200	1047	5.5	1251	6.6	1431	7.5	1590	8.4	1735	9.1
1300	1101	5.8	1293	6.8	1467	7.7	1622	8.5	1765	9.3
1400	1158	6.1	1337	7.0	1505	7.9	1657	8.7	1796	9.5
1500	1217	6.4	1383	7.3	1545	8.1	1693	8.9	1830	9.6
1600	1278	6.7	1432	7.5	1587	8.4	1731	9.1	1865	9.8
1700	1340	7.1	1483	7.8	1631	8.6	1771	9.3	—	—
1800	1404	7.4	1536	8.1	1677	8.8	1812	9.5	—	—
1900	1469	7.7	1592	8.4	1724	9.1	1855	9.8	—	—
2000	1535	8.1	1649	8.7	1774	9.3	1900	10.0	—	—

CFM	AVAILABLE EXTERNAL STATIC PRESSURE (in. wg)									
	1.2		1.4		1.6		1.8		2.0	
	rpm	vdc	rpm	vdc	rpm	vdc	rpm	vdc	rpm	vdc
1200	1869	9.8	—	—	—	—	—	—	—	—
1300	1897	10.0	—	—	—	—	—	—	—	—
1400	—	—	—	—	—	—	—	—	—	—
1500	—	—	—	—	—	—	—	—	—	—
1600	—	—	—	—	—	—	—	—	—	—
1700	—	—	—	—	—	—	—	—	—	—
1800	—	—	—	—	—	—	—	—	—	—
1900	—	—	—	—	—	—	—	—	—	—
2000	—	—	—	—	—	—	—	—	—	—

Standard Static 1047-1900 rpm

50GCQT05 Single Phase — Medium Static — 4 Ton Vertical Supply (rpm - vdc)

CFM	AVAILABLE EXTERNAL STATIC PRESSURE (in. wg)									
	0.2		0.4		0.6		0.8		1.0	
	rpm	vdc	rpm	vdc	rpm	vdc	rpm	vdc	rpm	vdc
1200	1047	4.8	1251	5.8	1431	6.6	1590	7.3	1735	8.0
1300	1101	5.1	1293	6.0	1467	6.8	1622	7.5	1765	8.1
1400	1158	5.3	1337	6.2	1505	6.9	1657	7.6	1796	8.3
1500	1217	5.6	1383	6.4	1545	7.1	1693	7.8	1830	8.4
1600	1278	5.9	1432	6.6	1587	7.3	1731	8.0	1865	8.6
1700	1340	6.2	1483	6.8	1631	7.5	1771	8.2	1902	8.8
1800	1404	6.5	1536	7.1	1677	7.7	1812	8.4	1940	8.9
1900	1469	6.8	1592	7.3	1724	7.9	1855	8.5	1980	9.1
2000	1535	7.1	1649	7.6	1774	8.2	1900	8.8	2021	9.3

CFM	AVAILABLE EXTERNAL STATIC PRESSURE (in. wg)									
	1.2		1.4		1.6		1.8		2.0	
	rpm	vdc	rpm	vdc	rpm	vdc	rpm	vdc	rpm	vdc
1200	1869	8.6	1994	9.2	2111	9.7	—	—	—	—
1300	1897	8.7	2020	9.3	2136	9.8	—	—	—	—
1400	1926	8.9	2047	9.4	2162	10.0	—	—	—	—
1500	1957	9.0	2077	9.6	—	—	—	—	—	—
1600	1990	9.2	2107	9.7	—	—	—	—	—	—
1700	2024	9.3	2140	9.9	—	—	—	—	—	—
1800	2060	9.5	—	—	—	—	—	—	—	—
1900	2097	9.7	—	—	—	—	—	—	—	—
2000	2136	9.8	—	—	—	—	—	—	—	—

Medium Static 1047-2170 rpm

50GCQT05 Single Phase — High Static — 4 Ton Vertical Supply (rpm - vdc)

CFM	AVAILABLE EXTERNAL STATIC PRESSURE (in. wg)									
	0.2		0.4		0.6		0.8		1.0	
	rpm	vdc	rpm	vdc	rpm	vdc	rpm	vdc	rpm	vdc
1200	1047	4.3	1251	5.1	1431	5.8	1590	6.5	1735	7.1
1300	1101	4.5	1293	5.3	1467	6.0	1622	6.6	1765	7.2
1400	1158	4.7	1337	5.4	1505	6.1	1657	6.7	1796	7.3
1500	1217	4.9	1383	5.6	1545	6.3	1693	6.9	1830	7.4
1600	1278	5.2	1432	5.8	1587	6.5	1731	7.0	1865	7.6
1700	1340	5.4	1483	6.0	1631	6.6	1771	7.2	1902	7.7
1800	1404	5.7	1536	6.2	1677	6.8	1812	7.4	1940	7.9
1900	1469	6.0	1592	6.5	1724	7.0	1855	7.5	1980	8.0
2000	1535	6.2	1649	6.7	1774	7.2	1900	7.7	2021	8.2

CFM	AVAILABLE EXTERNAL STATIC PRESSURE (in. wg)									
	1.2		1.4		1.6		1.8		2.0	
	rpm	vdc	rpm	vdc	rpm	vdc	rpm	vdc	rpm	vdc
1200	1869	7.6	1994	8.1	2111	8.6	2221	9.0	2324	9.4
1300	1897	7.7	2020	8.2	2136	8.7	2246	9.1	2350	9.6
1400	1926	7.8	2047	8.3	2162	8.8	2271	9.2	2375	9.7
1500	1957	8.0	2077	8.4	2190	8.9	2297	9.3	2400	9.8
1600	1990	8.1	2107	8.6	2219	9.0	2325	9.5	2427	9.9
1700	2024	8.2	2140	8.7	2249	9.1	2354	9.6	2455	10.0
1800	2060	8.4	2174	8.8	2282	9.3	2385	9.7	—	—
1900	2097	8.5	2209	9.0	2315	9.4	2417	9.8	—	—
2000	2136	8.7	2246	9.1	2350	9.6	2450	10.0	—	—

High Static 1047-2460 rpm

50GCQJ05 Three Phase — 4 Ton Vertical Supply (rpm - bhp)

CFM	AVAILABLE EXTERNAL STATIC PRESSURE (in. wg)									
	0.2		0.4		0.6		0.8		1.0	
	rpm	bhp	rpm	bhp	rpm	bhp	rpm	bhp	rpm	bhp
1200	1047	0.12	1252	0.21	1431	0.32	1590	0.43	1735	0.56
1300	1102	0.14	1293	0.23	1467	0.34	1622	0.46	1765	0.59
1400	1158	0.17	1337	0.26	1505	0.36	1657	0.49	1796	0.62
1500	1217	0.19	1383	0.28	1545	0.39	1693	0.52	1830	0.65
1600	1278	0.22	1432	0.31	1587	0.42	1732	0.55	1865	0.69
1700	1341	0.25	1483	0.34	1631	0.46	1771	0.59	1902	0.73
1800	1404	0.29	1536	0.38	1676	0.50	1813	0.63	1940	0.77
1900	1470	0.33	1592	0.42	1724	0.54	1855	0.67	1980	0.81
2000	1536	0.38	1649	0.47	1774	0.58	1900	0.72	2021	0.86

CFM	AVAILABLE EXTERNAL STATIC PRESSURE (in. wg)									
	1.2		1.4		1.6		1.8		2.0	
	rpm	bhp	rpm	bhp	rpm	bhp	rpm	bhp	rpm	bhp
1200	1869	0.70	1994	0.86	2111	1.02	2221	1.18	2324	1.35
1300	1897	0.73	2020	0.89	2136	1.05	2246	1.22	2350	1.39
1400	1926	0.76	2047	0.92	2162	1.08	2271	1.25	2375	1.43
1500	1957	0.80	2077	0.95	2190	1.12	2297	1.29	2400	1.47
1600	1990	0.84	2107	0.99	2219	1.16	2325	1.33	2427	1.52
1700	2024	0.88	2140	1.04	2250	1.20	2354	1.38	2455	1.56
1800	2060	0.92	2174	1.08	2282	1.25	2385	1.43	2484	1.61
1900	2098	0.97	2209	1.13	2315	1.30	2417	1.48	2515	1.67
2000	2137	1.02	2246	1.19	2351	1.36	2451	1.54	2547	1.73

- Standard Static 1047-1900 rpm, 0.72 Max bhp
- Medium Static 1047-2170 rpm, 1.06 Max bhp
- High Static 1047-2660 rpm, 1.96 Max bhp

50GCQJ05 Three Phase — Standard Static — 4 Ton Vertical Supply (rpm - vdc)

CFM	AVAILABLE EXTERNAL STATIC PRESSURE (in. wg)									
	0.2		0.4		0.6		0.8		1.0	
	rpm	vdc	rpm	vdc	rpm	vdc	rpm	vdc	rpm	vdc
1200	1047	5.5	1251	6.6	1431	7.5	1590	8.4	1735	9.1
1300	1101	5.8	1293	6.8	1467	7.7	1622	8.5	1765	9.3
1400	1158	6.1	1337	7.0	1505	7.9	1657	8.7	1796	9.5
1500	1217	6.4	1383	7.3	1545	8.1	1693	8.9	1830	9.6
1600	1277	6.7	1432	7.5	1587	8.4	1731	9.1	1865	9.8
1700	1340	7.1	1483	7.8	1631	8.6	1771	9.3	—	—
1800	1404	7.4	1536	8.1	1677	8.8	1812	9.5	—	—
1900	1469	7.7	1592	8.4	1724	9.1	1855	9.8	—	—
2000	1535	8.1	1649	8.7	1774	9.3	1900	10.0	—	—

CFM	AVAILABLE EXTERNAL STATIC PRESSURE (in. wg)									
	1.2		1.4		1.6		1.8		2.0	
	rpm	vdc	rpm	vdc	rpm	vdc	rpm	vdc	rpm	vdc
1200	1869	9.8	—	—	—	—	—	—	—	—
1300	1897	10.0	—	—	—	—	—	—	—	—
1400	—	—	—	—	—	—	—	—	—	—
1500	—	—	—	—	—	—	—	—	—	—
1600	—	—	—	—	—	—	—	—	—	—
1700	—	—	—	—	—	—	—	—	—	—
1800	—	—	—	—	—	—	—	—	—	—
1900	—	—	—	—	—	—	—	—	—	—
2000	—	—	—	—	—	—	—	—	—	—

- Standard Static 1047-1900 rpm

50GCQJ05 Three Phase — Medium Static — 4 Ton Vertical Supply (rpm - vdc)

CFM	AVAILABLE EXTERNAL STATIC PRESSURE (in. wg)									
	0.2		0.4		0.6		0.8		1.0	
	rpm	vdc	rpm	vdc	rpm	vdc	rpm	vdc	rpm	vdc
1200	1047	4.8	1251	5.8	1431	6.6	1590	7.3	1735	8.0
1300	1101	5.1	1293	6.0	1467	6.8	1622	7.5	1765	8.1
1400	1158	5.3	1337	6.2	1505	6.9	1657	7.6	1796	8.3
1500	1217	5.6	1383	6.4	1545	7.1	1693	7.8	1830	8.4
1600	1277	5.9	1432	6.6	1587	7.3	1731	8.0	1865	8.6
1700	1340	6.2	1483	6.8	1631	7.5	1771	8.2	1902	8.8
1800	1404	6.5	1536	7.1	1677	7.7	1812	8.4	1940	8.9
1900	1469	6.8	1592	7.3	1724	7.9	1855	8.5	1980	9.1
2000	1535	7.1	1649	7.6	1774	8.2	1900	8.8	2021	9.3

CFM	AVAILABLE EXTERNAL STATIC PRESSURE (in. wg)									
	1.2		1.4		1.6		1.8		2.0	
	rpm	vdc	rpm	vdc	rpm	vdc	rpm	vdc	rpm	vdc
1200	1869	8.6	1994	9.2	2111	9.7	—	—	—	—
1300	1897	8.7	2020	9.3	2136	9.8	—	—	—	—
1400	1926	8.9	2048	9.4	2162	10.0	—	—	—	—
1500	1957	9.0	2077	9.6	—	—	—	—	—	—
1600	1990	9.2	2107	9.7	—	—	—	—	—	—
1700	2024	9.3	2140	9.9	—	—	—	—	—	—
1800	2060	9.5	—	—	—	—	—	—	—	—
1900	2097	9.7	—	—	—	—	—	—	—	—
2000	2136	9.8	—	—	—	—	—	—	—	—

Medium Static 1047-2170 rpm

50GCQJ05 Three Phase — High Static — 4 Ton Vertical Supply (rpm - vdc)

CFM	AVAILABLE EXTERNAL STATIC PRESSURE (in. wg)									
	0.2		0.4		0.6		0.8		1.0	
	rpm	vdc	rpm	vdc	rpm	vdc	rpm	vdc	rpm	vdc
1200	1047	3.9	1251	4.7	1431	5.4	1590	6.0	1735	6.5
1300	1101	4.1	1293	4.9	1467	5.5	1622	6.1	1765	6.6
1400	1158	4.4	1337	5.0	1505	5.7	1657	6.2	1796	6.8
1500	1217	4.6	1383	5.2	1545	5.8	1693	6.4	1830	6.9
1600	1277	4.8	1432	5.4	1587	6.0	1731	6.5	1865	7.0
1700	1340	5.0	1483	5.6	1631	6.1	1771	6.7	1902	7.2
1800	1404	5.3	1536	5.8	1677	6.3	1812	6.8	1940	7.3
1900	1469	5.5	1592	6.0	1724	6.5	1855	7.0	1980	7.4
2000	1535	5.8	1649	6.2	1774	6.7	1900	7.1	2021	7.6

CFM	AVAILABLE EXTERNAL STATIC PRESSURE (in. wg)									
	1.2		1.4		1.6		1.8		2.0	
	rpm	Vdc	rpm	Vdc	rpm	Vdc	rpm	Vdc	rpm	Vdc
1200	1869	7.0	1994	7.5	2111	7.9	2221	8.3	2324	8.7
1300	1897	7.1	2020	7.6	2136	8.0	2246	8.4	2350	8.8
1400	1926	7.2	2048	7.7	2162	8.1	2271	8.5	2375	8.9
1500	1957	7.4	2077	7.8	2190	8.2	2298	8.6	2400	9.0
1600	1990	7.5	2107	7.9	2219	8.3	2325	8.7	2427	9.1
1700	2024	7.6	2140	8.0	2250	8.5	2354	8.8	2455	9.2
1800	2060	7.7	2174	8.2	2282	8.6	2385	9.0	2484	9.3
1900	2097	7.9	2209	8.3	2315	8.7	2417	9.1	2515	9.5
2000	2136	8.0	2246	8.4	2350	8.8	2451	9.2	2547	9.6

High Static 1047-2660 rpm

50GCQT06 Single Phase — 5 Ton Vertical Supply (rpm - bhp)

CFM	AVAILABLE EXTERNAL STATIC PRESSURE (in. wg)									
	0.2		0.4		0.6		0.8		1.0	
	rpm	bhp	rpm	bhp	rpm	bhp	rpm	bhp	rpm	bhp
1500	1228	0.20	1394	0.29	1554	0.40	1701	0.53	1836	0.66
1625	1305	0.24	1457	0.33	1609	0.44	1750	0.57	1882	0.71
1750	1384	0.28	1523	0.37	1666	0.49	1802	0.62	1930	0.76
1875	1466	0.33	1592	0.43	1726	0.54	1857	0.67	1981	0.82
2000	1549	0.39	1664	0.48	1789	0.60	1914	0.74	2034	0.88
2125	1633	0.46	1738	0.55	1855	0.67	1974	0.81	2089	0.95
2250	1718	0.53	1816	0.63	1924	0.74	2036	0.88	2146	1.03
2375	1803	0.61	1894	0.71	1995	0.83	2100	0.97	2206	1.12
2500	1889	0.70	1974	0.80	2068	0.92	2167	1.06	2268	1.21

CFM	AVAILABLE EXTERNAL STATIC PRESSURE (in. wg)									
	1.2		1.4		1.6		1.8		2.0	
	rpm	bhp	rpm	bhp	rpm	bhp	rpm	bhp	rpm	bhp
1500	1961	0.80	2079	0.96	2191	1.12	2298	1.29	—	—
1625	2004	0.85	2120	1.01	2230	1.18	2335	1.35	—	—
1750	2050	0.91	2163	1.07	2271	1.24	2374	1.41	—	—
1875	2098	0.97	2208	1.13	2314	1.31	—	—	—	—
2000	2148	1.04	2256	1.21	2359	1.38	—	—	—	—
2125	2200	1.11	2305	1.28	—	—	—	—	—	—
2250	2254	1.20	2357	1.37	—	—	—	—	—	—
2375	2310	1.28	—	—	—	—	—	—	—	—
2500	2368	1.38	—	—	—	—	—	—	—	—

Standard Static 1228-2150 rpm, 1.06 Max bhp

Medium Static 1228-2390 rpm, 1.44 Max bhp

50GCQT06 Single Phase — Standard Static — 5 Ton Vertical Supply (rpm - vdc)

CFM	AVAILABLE EXTERNAL STATIC PRESSURE (in. wg)									
	0.2		0.4		0.6		0.8		1.0	
	rpm	vdc	rpm	vdc	rpm	vdc	rpm	vdc	rpm	vdc
1500	1228	5.7	1394	6.5	1554	7.2	1701	7.9	1835	8.5
1625	1305	6.1	1456	6.8	1609	7.5	1750	8.1	1881	8.7
1750	1385	6.4	1523	7.1	1666	7.7	1802	8.4	1930	9.0
1875	1466	6.8	1592	7.4	1726	8.0	1857	8.6	1981	9.2
2000	1549	7.2	1664	7.7	1789	8.3	1914	8.9	2034	9.5
2125	1633	7.6	1739	8.1	1855	8.6	1974	9.2	2089	9.7
2250	1718	8.0	1816	8.4	1924	8.9	2036	9.5	2146	10.0
2375	1803	8.4	1894	8.8	1995	9.3	2100	9.8	—	—
2500	1890	8.8	1974	9.2	2068	9.6	—	—	—	—

CFM	AVAILABLE EXTERNAL STATIC PRESSURE (in. wg)									
	1.2		1.4		1.6		1.8		2.0	
	rpm	vdc	rpm	vdc	rpm	vdc	rpm	vdc	rpm	vdc
1500	1961	9.1	2079	9.7	—	—	—	—	—	—
1625	2004	9.3	2120	9.9	—	—	—	—	—	—
1750	2050	9.5	—	—	—	—	—	—	—	—
1875	2098	9.8	—	—	—	—	—	—	—	—
2000	2148	10.0	—	—	—	—	—	—	—	—
2125	—	—	—	—	—	—	—	—	—	—
2250	—	—	—	—	—	—	—	—	—	—
2375	—	—	—	—	—	—	—	—	—	—
2500	—	—	—	—	—	—	—	—	—	—

Standard Static 1228-2150 rpm

50GCQT06 Single Phase — Medium Static — 5 Ton Vertical Supply (rpm - vdc)

CFM	AVAILABLE EXTERNAL STATIC PRESSURE (in. wg)									
	0.2		0.4		0.6		0.8		1.0	
	rpm	vdc	rpm	vdc	rpm	vdc	rpm	vdc	rpm	vdc
1500	1228	5.1	1394	5.8	1554	6.5	1701	7.1	1835	7.7
1625	1305	5.5	1456	6.1	1609	6.7	1750	7.3	1881	7.9
1750	1385	5.8	1523	6.4	1666	7.0	1802	7.5	1930	8.1
1875	1466	6.1	1592	6.7	1726	7.2	1857	7.8	1981	8.3
2000	1549	6.5	1664	7.0	1789	7.5	1914	8.0	2034	8.5
2125	1633	6.8	1739	7.3	1855	7.8	1974	8.3	2089	8.7
2250	1718	7.2	1816	7.6	1924	8.1	2036	8.5	2146	9.0
2375	1803	7.5	1894	7.9	1995	8.3	2100	8.8	2206	9.2
2500	1890	7.9	1974	8.3	2068	8.7	2167	9.1	2268	9.5

CFM	AVAILABLE EXTERNAL STATIC PRESSURE (in. wg)									
	1.2		1.4		1.6		1.8		2.0	
	rpm	vdc	rpm	vdc	rpm	vdc	rpm	vdc	rpm	vdc
1500	1961	8.2	2079	8.7	2191	9.2	2297	9.6	—	—
1625	2004	8.4	2120	8.9	2229	9.3	2334	9.8	—	—
1750	2050	8.6	2163	9.1	2270	9.5	2373	9.9	—	—
1875	2098	8.8	2208	9.2	2314	9.7	—	—	—	—
2000	2148	9.0	2256	9.4	2359	9.9	—	—	—	—
2125	2200	9.2	2305	9.6	—	—	—	—	—	—
2250	2254	9.4	2357	9.9	—	—	—	—	—	—
2375	2310	9.7	—	—	—	—	—	—	—	—
2500	2368	9.9	—	—	—	—	—	—	—	—

Medium Static 1228-2390 rpm

50GCQJ06 Three Phase — 5 Ton Vertical Supply (rpm - bhp)

CFM	AVAILABLE EXTERNAL STATIC PRESSURE (in. wg)									
	0.2		0.4		0.6		0.8		1.0	
	rpm	bhp	rpm	bhp	rpm	bhp	rpm	bhp	rpm	bhp
1500	1228	0.20	1394	0.29	1554	0.40	1701	0.53	1836	0.66
1625	1305	0.24	1457	0.33	1609	0.44	1750	0.57	1882	0.71
1750	1384	0.28	1523	0.37	1666	0.49	1802	0.62	1930	0.76
1875	1466	0.33	1592	0.43	1726	0.54	1857	0.67	1981	0.82
2000	1549	0.39	1664	0.48	1789	0.60	1914	0.74	2034	0.88
2125	1633	0.46	1739	0.55	1855	0.67	1974	0.81	2089	0.95
2250	1718	0.53	1816	0.63	1924	0.74	2036	0.88	2146	1.03
2375	1803	0.61	1894	0.71	1995	0.83	2100	0.97	2206	1.12
2500	1890	0.70	1974	0.80	2068	0.92	2167	1.06	2268	1.21

CFM	AVAILABLE EXTERNAL STATIC PRESSURE (in. wg)									
	1.2		1.4		1.6		1.8		2.0	
	rpm	bhp	rpm	bhp	rpm	bhp	rpm	bhp	rpm	bhp
1500	1961	0.80	2079	0.96	2191	1.12	2297	1.29	2399	1.47
1625	2004	0.85	2120	1.01	2230	1.18	2334	1.35	2434	1.53
1750	2050	0.91	2163	1.07	2270	1.24	2373	1.41	2472	1.60
1875	2098	0.97	2208	1.13	2314	1.31	2414	1.48	2511	1.67
2000	2148	1.04	2256	1.21	2359	1.38	2458	1.56	2553	1.75
2125	2200	1.11	2305	1.28	2407	1.46	2504	1.64	2597	1.83
2250	2254	1.20	2357	1.37	2456	1.55	2551	1.73	2643	1.93
2375	2310	1.28	2410	1.46	2507	1.64	2600	1.83	2690	2.03
2500	2368	1.38	2465	1.56	2560	1.75	2651	1.94	2739	2.14

Standard Static 1228-2150 rpm, 1.06 Max bhp

Medium Static 1228-2390 rpm, 1.44 Max bhp

High Static 1228-2836 rpm, 2.43 Max bhp

50GCQJ06 Three Phase — Standard Static — 5 Ton Vertical Supply (rpm - vdc)

CFM	AVAILABLE EXTERNAL STATIC PRESSURE (in. wg)									
	0.2		0.4		0.6		0.8		1.0	
	rpm	vdc	rpm	vdc	rpm	vdc	rpm	vdc	rpm	vdc
1500	1227	5.7	1394	6.5	1554	7.2	1701	7.9	1835	8.5
1625	1305	6.1	1456	6.8	1609	7.5	1750	8.1	1881	8.7
1750	1385	6.4	1523	7.1	1666	7.7	1802	8.4	1930	9.0
1875	1466	6.8	1592	7.4	1726	8.0	1857	8.6	1981	9.2
2000	1549	7.2	1664	7.7	1789	8.3	1914	8.9	2034	9.5
2125	1632	7.6	1739	8.1	1855	8.6	1974	9.2	2089	9.7
2250	1718	8.0	1816	8.4	1924	8.9	2035	9.5	2146	10.0
2375	1803	8.4	1894	8.8	1994	9.3	2100	9.8	—	—
2500	1890	8.8	1974	9.2	2068	9.6	—	—	—	—

CFM	AVAILABLE EXTERNAL STATIC PRESSURE (in. wg)									
	1.2		1.4		1.6		1.8		2.0	
	rpm	vdc	rpm	vdc	rpm	vdc	rpm	vdc	rpm	vdc
1500	1961	9.1	2079	9.7	—	—	—	—	—	—
1625	2004	9.3	2120	9.9	—	—	—	—	—	—
1750	2050	9.5	—	—	—	—	—	—	—	—
1875	2097	9.8	—	—	—	—	—	—	—	—
2000	2147	10.0	—	—	—	—	—	—	—	—
2125	—	—	—	—	—	—	—	—	—	—
2250	—	—	—	—	—	—	—	—	—	—
2375	—	—	—	—	—	—	—	—	—	—
2500	—	—	—	—	—	—	—	—	—	—

Standard Static 1227-2150 rpm

50GCQJ06 Three Phase — Medium Static — 5 Ton Vertical Supply (rpm - vdc)

CFM	AVAILABLE EXTERNAL STATIC PRESSURE (in. wg)									
	0.2		0.4		0.6		0.8		1.0	
	rpm	vdc	rpm	vdc	rpm	vdc	rpm	vdc	rpm	vdc
1500	1227	5.1	1394	5.8	1554	6.5	1701	7.1	1835	7.7
1625	1305	5.5	1456	6.1	1609	6.7	1750	7.3	1881	7.9
1750	1385	5.8	1523	6.4	1666	7.0	1802	7.5	1930	8.1
1875	1466	6.1	1592	6.7	1726	7.2	1857	7.8	1981	8.3
2000	1549	6.5	1664	7.0	1789	7.5	1914	8.0	2034	8.5
2125	1632	6.8	1739	7.3	1855	7.8	1974	8.3	2089	8.7
2250	1718	7.2	1816	7.6	1924	8.1	2035	8.5	2146	9.0
2375	1803	7.5	1894	7.9	1994	8.3	2100	8.8	2206	9.2
2500	1890	7.9	1974	8.3	2068	8.7	2167	9.1	2268	9.5

CFM	AVAILABLE EXTERNAL STATIC PRESSURE (in. wg)									
	1.2		1.4		1.6		1.8		2.0	
	rpm	vdc	rpm	vdc	rpm	vdc	rpm	vdc	rpm	vdc
1500	1961	8.2	2079	8.7	2191	9.2	2297	9.6	—	—
1625	2004	8.4	2120	8.9	2229	9.3	2334	9.8	—	—
1750	2050	8.6	2163	9.1	2270	9.5	2373	9.9	—	—
1875	2097	8.8	2208	9.2	2314	9.7	—	—	—	—
2000	2147	9.0	2256	9.4	2359	9.9	—	—	—	—
2125	2199	9.2	2305	9.6	—	—	—	—	—	—
2250	2254	9.4	2357	9.9	—	—	—	—	—	—
2375	2310	9.7	—	—	—	—	—	—	—	—
2500	2367	9.9	—	—	—	—	—	—	—	—

Medium Static 1227-2390 rpm

50GCQJ06 Three Phase — High Static — 5 Ton Vertical Supply (rpm - vdc)

CFM	AVAILABLE EXTERNAL STATIC PRESSURE (in. wg)									
	0.2		0.4		0.6		0.8		1.0	
	rpm	vdc	rpm	vdc	rpm	vdc	rpm	vdc	rpm	vdc
1500	1227	4.3	1394	4.9	1554	5.5	1701	6.0	1835	6.5
1625	1305	4.6	1456	5.1	1609	5.7	1750	6.2	1881	6.6
1750	1385	4.9	1523	5.4	1666	5.9	1802	6.4	1930	6.8
1875	1466	5.2	1592	5.6	1726	6.1	1857	6.5	1981	7.0
2000	1549	5.5	1664	5.9	1789	6.3	1914	6.7	2034	7.2
2125	1632	5.8	1739	6.1	1855	6.5	1974	7.0	2089	7.4
2250	1718	6.1	1816	6.4	1924	6.8	2035	7.2	2146	7.6
2375	1803	6.4	1894	6.7	1994	7.0	2100	7.4	2206	7.8
2500	1890	6.7	1974	7.0	2068	7.3	2167	7.6	2268	8.0

CFM	AVAILABLE EXTERNAL STATIC PRESSURE (in. wg)									
	1.2		1.4		1.6		1.8		2.0	
	rpm	vdc	rpm	vdc	rpm	vdc	rpm	vdc	rpm	vdc
1500	1961	6.9	2079	7.3	2191	7.7	2297	8.1	2399	8.5
1625	2004	7.1	2120	7.5	2229	7.9	2334	8.2	2434	8.6
1750	2050	7.2	2163	7.6	2270	8.0	2373	8.4	2472	8.7
1875	2097	7.4	2208	7.8	2314	8.2	2414	8.5	2511	8.9
2000	2147	7.6	2256	8.0	2359	8.3	2458	8.7	2553	9.0
2125	2199	7.8	2305	8.1	2406	8.5	2503	8.8	2597	9.2
2250	2254	7.9	2357	8.3	2456	8.7	2551	9.0	2643	9.3
2375	2310	8.1	2410	8.5	2507	8.8	2600	9.2	2690	9.5
2500	2367	8.3	2465	8.7	2560	9.0	2651	9.3	2739	9.7

High Static 1227-2836 rpm

50GCQT04 Single Phase — 3 Ton Horizontal Supply (rpm - bhp)

CFM	AVAILABLE EXTERNAL STATIC PRESSURE (in. wg)									
	0.2		0.4		0.6		0.8		1.0	
	rpm	bhp	rpm	bhp	rpm	bhp	rpm	bhp	rpm	bhp
900	1036	0.08	1301	0.15	1517	0.24	1698	0.34	1855	0.44
975	1077	0.09	1331	0.16	1546	0.26	1727	0.36	1885	0.47
1050	1119	0.10	1362	0.18	1574	0.27	1755	0.38	1915	0.49
1125	1164	0.11	1394	0.19	1603	0.29	1783	0.39	1944	0.51
1200	1211	0.12	1429	0.20	1632	0.30	1813	0.41	1972	0.53
1275	1261	0.14	1466	0.22	1663	0.32	1841	0.43	2000	0.56
1350	1312	0.16	1506	0.24	1695	0.34	1870	0.46	2029	0.58
1425	1365	0.18	1547	0.26	1729	0.36	1901	0.48	2057	0.61
1500	1419	0.20	1591	0.28	1765	0.38	1932	0.50	2087	0.63

CFM	AVAILABLE EXTERNAL STATIC PRESSURE (in. wg)									
	1.2		1.4		1.6		1.8		2.0	
	rpm	bhp	rpm	bhp	rpm	bhp	rpm	bhp	rpm	bhp
900	1996	0.55	2123	0.67	2242	0.78	2352	0.91	2455	1.03
975	2027	0.58	2157	0.70	2276	0.82	2387	0.95	—	—
1050	2058	0.61	2189	0.73	2309	0.86	2421	0.99	—	—
1125	2088	0.63	2219	0.76	2341	0.89	2454	1.03	—	—
1200	2117	0.66	2249	0.79	2372	0.93	2486	1.07	—	—
1275	2146	0.69	2278	0.82	2402	0.97	—	—	—	—
1350	2174	0.72	2307	0.86	2431	1.00	—	—	—	—
1425	2202	0.74	2336	0.89	2460	1.04	—	—	—	—
1500	2230	0.77	2364	0.92	2488	1.07	—	—	—	—

Standard Static 1036-1890 rpm, 0.44 Max bhp

Medium Static 1036-2190 rpm, 0.71 Max bhp

High Static 1036-2490 rpm, 1.07 Max bhp

50GCQT04 Single Phase — Standard Static — 3 Ton Horizontal Supply (rpm - vdc)

CFM	AVAILABLE EXTERNAL STATIC PRESSURE (in. wg)									
	0.2		0.4		0.6		0.8		1.0	
	rpm	vdc	rpm	vdc	rpm	vdc	rpm	vdc	rpm	vdc
900	1036	5.5	1301	6.9	1517	8.0	1698	9.0	1855	9.8
975	1077	5.7	1331	7.0	1546	8.2	1727	9.1	1885	10.0
1050	1119	5.9	1362	7.2	1574	8.3	1755	9.3	—	—
1125	1164	6.2	1394	7.4	1603	8.5	1783	9.4	—	—
1200	1211	6.4	1429	7.6	1632	8.6	1813	9.6	—	—
1275	1261	6.7	1466	7.8	1663	8.8	1841	9.7	—	—
1350	1312	6.9	1506	8.0	1695	9.0	1870	9.9	—	—
1425	1365	7.2	1547	8.2	1729	9.1	—	—	—	—
1500	1419	7.5	1591	8.4	1765	9.3	—	—	—	—

CFM	AVAILABLE EXTERNAL STATIC PRESSURE (in. wg)									
	1.2		1.4		1.6		1.8		2.0	
	rpm	vdc	rpm	vdc	rpm	vdc	rpm	vdc	rpm	vdc
900	—	—	—	—	—	—	—	—	—	—
975	—	—	—	—	—	—	—	—	—	—
1050	—	—	—	—	—	—	—	—	—	—
1125	—	—	—	—	—	—	—	—	—	—
1200	—	—	—	—	—	—	—	—	—	—
1275	—	—	—	—	—	—	—	—	—	—
1350	—	—	—	—	—	—	—	—	—	—
1425	—	—	—	—	—	—	—	—	—	—
1500	—	—	—	—	—	—	—	—	—	—

Standard Static 1036-1890 rpm

50GCQT04 Single Phase — Medium Static — 3 Ton Horizontal Supply (rpm - vdc)

CFM	AVAILABLE EXTERNAL STATIC PRESSURE (in. wg)									
	0.2		0.4		0.6		0.8		1.0	
	rpm	Vdc	rpm	Vdc	rpm	Vdc	rpm	Vdc	rpm	Vdc
900	1036	4.7	1301	5.9	1517	6.9	1698	7.8	1855	8.5
975	1077	4.9	1331	6.1	1546	7.1	1727	7.9	1885	8.6
1050	1119	5.1	1362	6.2	1574	7.2	1755	8.0	1915	8.7
1125	1164	5.3	1394	6.4	1603	7.3	1783	8.1	1944	8.9
1200	1211	5.5	1429	6.5	1632	7.5	1813	8.3	1972	9.0
1275	1261	5.8	1466	6.7	1663	7.6	1841	8.4	2000	9.1
1350	1312	6.0	1506	6.9	1695	7.7	1870	8.5	2029	9.3
1425	1365	6.2	1547	7.1	1729	7.9	1901	8.7	2057	9.4
1500	1419	6.5	1591	7.3	1765	8.1	1932	8.8	2087	9.5

CFM	AVAILABLE EXTERNAL STATIC PRESSURE (in. wg)									
	1.2		1.4		1.6		1.8		2.0	
	rpm	vdc	rpm	vdc	rpm	vdc	rpm	vdc	rpm	vdc
900	1996	9.1	2123	9.7	—	—	—	—	—	—
975	2027	9.3	2157	9.8	—	—	—	—	—	—
1050	2058	9.4	2189	10.0	—	—	—	—	—	—
1125	2088	9.5	—	—	—	—	—	—	—	—
1200	2117	9.7	—	—	—	—	—	—	—	—
1275	2146	9.8	—	—	—	—	—	—	—	—
1350	2174	9.9	—	—	—	—	—	—	—	—
1425	—	—	—	—	—	—	—	—	—	—
1500	—	—	—	—	—	—	—	—	—	—

Medium Static 1036-2190 rpm

50GCQT04 Single Phase — High Static — 3 Ton Horizontal Supply (rpm - vdc)

CFM	AVAILABLE EXTERNAL STATIC PRESSURE (in. wg)									
	0.2		0.4		0.6		0.8		1.0	
	rpm	vdc	rpm	vdc	rpm	vdc	rpm	vdc	rpm	vdc
900	1036	4.2	1301	5.2	1517	6.1	1698	6.8	1855	7.4
975	1077	4.3	1331	5.3	1546	6.2	1727	6.9	1885	7.6
1050	1119	4.5	1362	5.5	1574	6.3	1755	7.0	1915	7.7
1125	1164	4.7	1394	5.6	1603	6.4	1783	7.2	1944	7.8
1200	1211	4.9	1429	5.7	1632	6.6	1813	7.3	1972	7.9
1275	1261	5.1	1466	5.9	1663	6.7	1841	7.4	2000	8.0
1350	1312	5.3	1506	6.0	1695	6.8	1870	7.5	2029	8.1
1425	1365	5.5	1547	6.2	1729	6.9	1901	7.6	2057	8.3
1500	1419	5.7	1591	6.4	1765	7.1	1932	7.8	2087	8.4

CFM	AVAILABLE EXTERNAL STATIC PRESSURE (in. wg)									
	1.2		1.4		1.6		1.8		2.0	
	rpm	vdc	rpm	vdc	rpm	vdc	rpm	vdc	rpm	vdc
900	1996	8.0	2123	8.5	2242	9.0	2352	9.4	2455	9.9
975	2027	8.1	2157	8.7	2276	9.1	2387	9.6	—	—
1050	2058	8.3	2189	8.8	2309	9.3	2421	9.7	—	—
1125	2088	8.4	2219	8.9	2341	9.4	2454	9.9	—	—
1200	2117	8.5	2249	9.0	2372	9.5	2486	10.0	—	—
1275	2146	8.6	2278	9.1	2402	9.6	—	—	—	—
1350	2174	8.7	2307	9.3	2431	9.8	—	—	—	—
1425	2202	8.8	2336	9.4	2460	9.9	—	—	—	—
1500	2230	9.0	2364	9.5	2488	10.0	—	—	—	—

High Static 1036-2490 rpm

50GCQJ04 Three Phase — 3 Ton Horizontal Supply (rpm - bhp)

CFM	AVAILABLE EXTERNAL STATIC PRESSURE (in. wg)									
	0.2		0.4		0.6		0.8		1.0	
	rpm	bhp	rpm	bhp	rpm	bhp	rpm	bhp	rpm	bhp
900	1037	0.08	1301	0.15	1517	0.24	1698	0.34	1855	0.44
975	1076	0.09	1330	0.16	1545	0.26	1727	0.36	1886	0.47
1050	1119	0.10	1361	0.18	1574	0.27	1755	0.38	1915	0.49
1125	1164	0.11	1394	0.19	1602	0.29	1784	0.40	1944	0.51
1200	1212	0.12	1430	0.20	1632	0.30	1813	0.41	1972	0.53
1275	1261	0.14	1466	0.22	1663	0.32	1840	0.43	2001	0.56
1350	1313	0.16	1506	0.24	1695	0.34	1870	0.46	2029	0.58
1425	1366	0.18	1547	0.26	1729	0.36	1900	0.48	2057	0.61
1500	1420	0.20	1591	0.28	1765	0.38	1932	0.50	2087	0.63

CFM	AVAILABLE EXTERNAL STATIC PRESSURE (in. wg)									
	1.2		1.4		1.6		1.8		2.0	
	rpm	bhp	rpm	bhp	rpm	bhp	rpm	bhp	rpm	bhp
900	1996	0.55	2124	0.67	2242	0.78	2352	0.91	2455	1.03
975	2028	0.58	2157	0.70	2276	0.82	2387	0.95	—	—
1050	2058	0.61	2189	0.73	2309	0.86	2421	0.99	—	—
1125	2088	0.63	2219	0.76	2341	0.89	2454	1.03	—	—
1200	2117	0.66	2249	0.79	2372	0.93	2486	1.07	—	—
1275	2146	0.69	2278	0.82	2402	0.97	—	—	—	—
1350	2174	0.72	2307	0.86	2431	1.00	—	—	—	—
1425	2203	0.74	2336	0.89	2460	1.04	—	—	—	—
1500	2230	0.77	2364	0.92	2488	1.07	—	—	—	—

Standard Static 1137-1890 rpm, 0.44 Max bhp

Medium Static 1137-2190 rpm, 0.71 Max bhp

High Static 1137-2490 rpm, 1.07 Max bhp

50GCQJ04 Three Phase — Standard Static — 3 Ton Horizontal Supply (rpm - vdc)

CFM	AVAILABLE EXTERNAL STATIC PRESSURE (in. wg)									
	0.2		0.4		0.6		0.8		1.0	
	rpm	vdc	rpm	vdc	rpm	vdc	rpm	vdc	rpm	vdc
900	1037	5.5	1301	6.9	1517	8.0	1698	9.0	1855	9.8
975	1076	5.7	1330	7.0	1545	8.2	1727	9.1	1886	10.0
1050	1119	5.9	1361	7.2	1574	8.3	1755	9.3	—	—
1125	1164	6.2	1394	7.4	1602	8.5	1784	9.4	—	—
1200	1212	6.4	1430	7.6	1632	8.6	1813	9.6	—	—
1275	1261	6.7	1466	7.8	1663	8.8	1840	9.7	—	—
1350	1313	6.9	1506	8.0	1695	9.0	1870	9.9	—	—
1425	1366	7.2	1547	8.2	1729	9.1	—	—	—	—
1500	1420	7.5	1591	8.4	1765	9.3	—	—	—	—

CFM	AVAILABLE EXTERNAL STATIC PRESSURE (in. wg)									
	1.2		1.4		1.6		1.8		2.0	
	rpm	vdc	rpm	vdc	rpm	vdc	rpm	vdc	rpm	vdc
900	—	—	—	—	—	—	—	—	—	—
975	—	—	—	—	—	—	—	—	—	—
1050	—	—	—	—	—	—	—	—	—	—
1125	—	—	—	—	—	—	—	—	—	—
1200	—	—	—	—	—	—	—	—	—	—
1275	—	—	—	—	—	—	—	—	—	—
1350	—	—	—	—	—	—	—	—	—	—
1425	—	—	—	—	—	—	—	—	—	—
1500	—	—	—	—	—	—	—	—	—	—

Standard Static 1137-1890 rpm

50GCQJ04 Three Phase — Medium Static — 3 Ton Horizontal Supply (rpm - vdc)

CFM	AVAILABLE EXTERNAL STATIC PRESSURE (in. wg)									
	0.2		0.4		0.6		0.8		1.0	
	rpm	vdc	rpm	vdc	rpm	vdc	rpm	vdc	rpm	vdc
900	1037	4.7	1301	5.9	1517	6.9	1698	7.8	1855	8.5
975	1076	4.9	1330	6.1	1545	7.1	1727	7.9	1886	8.6
1050	1119	5.1	1361	6.2	1574	7.2	1755	8.0	1915	8.7
1125	1164	5.3	1394	6.4	1602	7.3	1784	8.1	1944	8.9
1200	1212	5.5	1430	6.5	1632	7.5	1813	8.3	1972	9.0
1275	1261	5.8	1466	6.7	1663	7.6	1840	8.4	2001	9.1
1350	1313	6.0	1506	6.9	1695	7.7	1870	8.5	2029	9.3
1425	1366	6.2	1547	7.1	1729	7.9	1900	8.7	2057	9.4
1500	1420	6.5	1591	7.3	1765	8.1	1932	8.8	2087	9.5

CFM	AVAILABLE EXTERNAL STATIC PRESSURE (in. wg)									
	1.2		1.4		1.6		1.8		2.0	
	rpm	vdc	rpm	vdc	rpm	vdc	rpm	vdc	rpm	vdc
900	1996	9.1	2124	9.7	—	—	—	—	—	—
975	2028	9.3	2157	9.8	—	—	—	—	—	—
1050	2058	9.4	2189	10.0	—	—	—	—	—	—
1125	2088	9.5	—	—	—	—	—	—	—	—
1200	2117	9.7	—	—	—	—	—	—	—	—
1275	2146	9.8	—	—	—	—	—	—	—	—
1350	2174	9.9	—	—	—	—	—	—	—	—
1425	—	—	—	—	—	—	—	—	—	—
1500	—	—	—	—	—	—	—	—	—	—

Medium Static 1137-2190 rpm

50GCQJ04 Three Phase — High Static — 3 Ton Horizontal Supply (rpm - vdc)

CFM	AVAILABLE EXTERNAL STATIC PRESSURE (in. wg)									
	0.2		0.4		0.6		0.8		1.0	
	rpm	vdc	rpm	vdc	rpm	vdc	rpm	vdc	rpm	vdc
900	1037	4.2	1301	5.2	1517	6.1	1698	6.8	1855	7.4
975	1076	4.3	1330	5.3	1545	6.2	1727	6.9	1886	7.6
1050	1119	4.5	1361	5.5	1574	6.3	1755	7.0	1915	7.7
1125	1164	4.7	1394	5.6	1602	6.4	1784	7.2	1944	7.8
1200	1212	4.9	1430	5.7	1632	6.6	1813	7.3	1972	7.9
1275	1261	5.1	1466	5.9	1663	6.7	1840	7.4	2001	8.0
1350	1313	5.3	1506	6.0	1695	6.8	1870	7.5	2029	8.1
1425	1366	5.5	1547	6.2	1729	6.9	1900	7.6	2057	8.3
1500	1420	5.7	1591	6.4	1765	7.1	1932	7.8	2087	8.4

CFM	AVAILABLE EXTERNAL STATIC PRESSURE (in. wg)									
	1.2		1.4		1.6		1.8		2.0	
	rpm	vdc	rpm	vdc	rpm	vdc	rpm	vdc	rpm	vdc
900	1996	8.0	2124	8.5	2242	9.0	2352	9.4	2455	9.9
975	2028	8.1	2157	8.7	2276	9.1	2387	9.6	—	—
1050	2058	8.3	2189	8.8	2309	9.3	2421	9.7	—	—
1125	2088	8.4	2219	8.9	2341	9.4	2454	9.9	—	—
1200	2117	8.5	2249	9.0	2372	9.5	2486	10.0	—	—
1275	2146	8.6	2278	9.1	2402	9.6	—	—	—	—
1350	2174	8.7	2307	9.3	2431	9.8	—	—	—	—
1425	2203	8.8	2336	9.4	2460	9.9	—	—	—	—
1500	2230	9.0	2364	9.5	2488	10.0	—	—	—	—

High Static 1137-2490 rpm

50GCQT05 Single Phase — 4 Ton Horizontal Supply (rpm - bhp)

CFM	AVAILABLE EXTERNAL STATIC PRESSURE (in. wg)									
	0.2		0.4		0.6		0.8		1.0	
	rpm	bhp	rpm	bhp	rpm	bhp	rpm	bhp	rpm	bhp
1200	1021	0.11	1227	0.19	1417	0.30	1586	0.42	1738	0.55
1300	1073	0.13	1265	0.21	1447	0.31	1612	0.43	1762	0.57
1400	1128	0.15	1305	0.23	1479	0.33	1640	0.46	1788	0.59
1500	1185	0.17	1349	0.25	1514	0.36	1670	0.48	1815	0.61
1600	1244	0.20	1396	0.28	1553	0.38	1703	0.51	1844	0.64
1700	1304	0.23	1446	0.31	1593	0.41	1737	0.53	1875	0.67
1800	1365	0.26	1498	0.34	1636	0.45	1774	0.57	1907	0.71
1900	1427	0.29	1551	0.38	1681	0.48	1813	0.60	1942	0.74
2000	1490	0.33	1607	0.42	1730	0.52	1855	0.65	1978	0.78

CFM	AVAILABLE EXTERNAL STATIC PRESSURE (in. wg)									
	1.2		1.4		1.6		1.8		2.0	
	rpm	bhp	rpm	bhp	rpm	bhp	rpm	bhp	rpm	bhp
1200	1875	0.69	2003	0.84	2123	1.00	2237	1.17	2345	1.35
1300	1899	0.71	2026	0.86	2145	1.02	2258	1.19	2365	1.37
1400	1925	0.74	2050	0.89	2169	1.05	2280	1.22	2387	1.40
1500	1950	0.76	2076	0.92	2193	1.08	2304	1.26	2409	1.44
1600	1977	0.79	2101	0.95	2218	1.12	2328	1.29	2433	1.47
1700	2005	0.82	2127	0.98	2244	1.15	2353	1.33	2457	1.51
1800	2034	0.86	2155	1.02	2270	1.19	2379	1.37	—	—
1900	2066	0.89	2184	1.06	2297	1.23	2405	1.41	—	—
2000	2099	0.94	2215	1.10	2326	1.27	2432	1.45	—	—

Standard Static 1021-1900 rpm, 0.72 Max bhp

Medium Static 1021-2170 rpm, 1.06 Max bhp

High Static 1021-2460 rpm, 1.53 Max bhp

50GCQT05 Single Phase — Standard Static — 4 Ton Horizontal Supply (rpm - vdc)

CFM	AVAILABLE EXTERNAL STATIC PRESSURE (in. wg)									
	0.2		0.4		0.6		0.8		1.0	
	rpm	vdc	rpm	vdc	rpm	vdc	rpm	vdc	rpm	vdc
1200	1021	5.4	1227	6.5	1417	7.5	1586	8.3	1738	9.1
1300	1073	5.6	1265	6.7	1447	7.6	1612	8.5	1762	9.3
1400	1128	5.9	1305	6.9	1479	7.8	1640	8.6	1788	9.4
1500	1185	6.2	1349	7.1	1514	8.0	1670	8.8	1815	9.6
1600	1244	6.5	1396	7.3	1553	8.2	1703	9.0	1844	9.7
1700	1304	6.9	1446	7.6	1593	8.4	1737	9.1	1875	9.9
1800	1365	7.2	1498	7.9	1636	8.6	1774	9.3	—	—
1900	1427	7.5	1551	8.2	1681	8.8	1813	9.5	—	—
2000	1490	7.8	1607	8.5	1730	9.1	1855	9.8	—	—

CFM	AVAILABLE EXTERNAL STATIC PRESSURE (in. wg)									
	1.2		1.4		1.6		1.8		2.0	
	rpm	vdc	rpm	vdc	rpm	vdc	rpm	vdc	rpm	vdc
1200	1875	9.9	—	—	—	—	—	—	—	—
1300	1899	10.0	—	—	—	—	—	—	—	—
1400	—	—	—	—	—	—	—	—	—	—
1500	—	—	—	—	—	—	—	—	—	—
1600	—	—	—	—	—	—	—	—	—	—
1700	—	—	—	—	—	—	—	—	—	—
1800	—	—	—	—	—	—	—	—	—	—
1900	—	—	—	—	—	—	—	—	—	—
2000	—	—	—	—	—	—	—	—	—	—

Standard Static 1021-1900 rpm

50GCQT05 Single Phase — Medium Static — 4 Ton Horizontal Supply (rpm - vdc)

CFM	AVAILABLE EXTERNAL STATIC PRESSURE (in. wg)									
	0.2		0.4		0.6		0.8		1.0	
	rpm	vdc	rpm	vdc	rpm	vdc	rpm	vdc	rpm	vdc
1200	1021	4.7	1227	5.7	1417	6.5	1586	7.3	1738	8.0
1300	1073	4.9	1265	5.8	1447	6.7	1612	7.4	1762	8.1
1400	1128	5.2	1305	6.0	1479	6.8	1640	7.6	1788	8.2
1500	1185	5.5	1349	6.2	1514	7.0	1670	7.7	1815	8.4
1600	1244	5.7	1396	6.4	1553	7.2	1703	7.8	1844	8.5
1700	1304	6.0	1446	6.7	1593	7.3	1737	8.0	1875	8.6
1800	1365	6.3	1498	6.9	1636	7.5	1774	8.2	1907	8.8
1900	1427	6.6	1551	7.1	1681	7.7	1813	8.4	1942	8.9
2000	1490	6.9	1607	7.4	1730	8.0	1855	8.5	1978	9.1

CFM	AVAILABLE EXTERNAL STATIC PRESSURE (in. wg)									
	1.2		1.4		1.6		1.8		2.0	
	rpm	vdc	rpm	vdc	rpm	vdc	rpm	vdc	rpm	vdc
1200	1875	8.6	2003	9.2	2123	9.8	—	—	—	—
1300	1899	8.8	2026	9.3	2145	9.9	—	—	—	—
1400	1925	8.9	2050	9.4	2169	10.0	—	—	—	—
1500	1950	9.0	2076	9.6	—	—	—	—	—	—
1600	1977	9.1	2101	9.7	—	—	—	—	—	—
1700	2005	9.2	2127	9.8	—	—	—	—	—	—
1800	2034	9.4	2155	9.9	—	—	—	—	—	—
1900	2066	9.5	—	—	—	—	—	—	—	—
2000	2099	9.7	—	—	—	—	—	—	—	—

Medium Static 1021-2170 rpm

50GCQT05 Single Phase — High Static — 4 Ton Horizontal Supply (rpm - vdc)

CFM	AVAILABLE EXTERNAL STATIC PRESSURE (in. wg)									
	0.2		0.4		0.6		0.8		1.0	
	rpm	vdc	rpm	vdc	rpm	vdc	rpm	vdc	rpm	vdc
1200	1021	4.2	1227	5.0	1417	5.8	1586	6.4	1738	7.1
1300	1073	4.4	1265	5.1	1447	5.9	1612	6.6	1762	7.2
1400	1128	4.6	1305	5.3	1479	6.0	1640	6.7	1788	7.3
1500	1185	4.8	1349	5.5	1514	6.2	1670	6.8	1815	7.4
1600	1244	5.1	1396	5.7	1553	6.3	1703	6.9	1844	7.5
1700	1304	5.3	1446	5.9	1593	6.5	1737	7.1	1875	7.6
1800	1365	5.5	1498	6.1	1636	6.7	1774	7.2	1907	7.8
1900	1427	5.8	1551	6.3	1681	6.8	1813	7.4	1942	7.9
2000	1490	6.1	1607	6.5	1730	7.0	1855	7.5	1978	8.0

CFM	AVAILABLE EXTERNAL STATIC PRESSURE (in. wg)									
	1.2		1.4		1.6		1.8		2.0	
	rpm	vdc	rpm	vdc	rpm	vdc	rpm	vdc	rpm	vdc
1200	1875	7.6	2003	8.1	2123	8.6	2237	9.1	2345	9.5
1300	1899	7.7	2026	8.2	2145	8.7	2258	9.2	2365	9.6
1400	1925	7.8	2050	8.3	2169	8.8	2280	9.3	2387	9.7
1500	1950	7.9	2076	8.4	2193	8.9	2304	9.4	2409	9.8
1600	1977	8.0	2101	8.5	2218	9.0	2328	9.5	2433	9.9
1700	2005	8.2	2127	8.6	2244	9.1	2353	9.6	2457	10.0
1800	2034	8.3	2155	8.8	2270	9.2	2379	9.7	—	—
1900	2066	8.4	2184	8.9	2297	9.3	2405	9.8	—	—
2000	2099	8.5	2215	9.0	2326	9.5	2432	9.9	—	—

High Static 1021-2460 rpm

50GCQJ05 Three Phase — 4 Ton Horizontal Supply (rpm - bhp)

CFM	AVAILABLE EXTERNAL STATIC PRESSURE (in. wg)									
	0.2		0.4		0.6		0.8		1.0	
	rpm	bhp	rpm	bhp	rpm	bhp	rpm	bhp	rpm	bhp
1200	1022	0.11	1228	0.19	1417	0.30	1586	0.42	1737	0.55
1300	1074	0.13	1265	0.21	1447	0.31	1613	0.44	1762	0.57
1400	1129	0.15	1306	0.23	1479	0.33	1641	0.46	1788	0.59
1500	1186	0.17	1350	0.25	1514	0.36	1671	0.48	1816	0.62
1600	1244	0.20	1397	0.28	1553	0.38	1703	0.51	1845	0.64
1700	1304	0.23	1446	0.31	1593	0.41	1737	0.53	1875	0.67
1800	1365	0.26	1498	0.34	1636	0.45	1774	0.57	1907	0.71
1900	1427	0.29	1552	0.38	1682	0.48	1814	0.61	1942	0.74
2000	1490	0.33	1607	0.42	1730	0.52	1855	0.65	1978	0.78

CFM	AVAILABLE EXTERNAL STATIC PRESSURE (in. wg)									
	1.2		1.4		1.6		1.8		2.0	
	rpm	bhp	rpm	bhp	rpm	bhp	rpm	bhp	rpm	bhp
1200	1875	0.69	2003	0.84	2123	1.00	2237	1.17	2345	1.35
1300	1899	0.71	2026	0.86	2145	1.02	2258	1.19	2365	1.37
1400	1924	0.74	2050	0.89	2169	1.05	2280	1.22	2387	1.40
1500	1950	0.76	2075	0.92	2193	1.08	2304	1.26	2409	1.44
1600	1977	0.79	2101	0.95	2218	1.12	2328	1.29	2433	1.47
1700	2005	0.82	2128	0.98	2243	1.15	2353	1.33	2457	1.51
1800	2035	0.86	2156	1.02	2270	1.19	2379	1.37	2482	1.55
1900	2066	0.89	2185	1.06	2298	1.23	2405	1.41	2508	1.60
2000	2099	0.94	2215	1.10	2326	1.27	2433	1.46	2535	1.65

Standard Static 1022-1900 rpm, 0.72 Max bhp

Medium Static 1022-2170 rpm, 1.06 Max bhp

High Static 1022-2660 rpm, 1.96 Max bhp

50GCQJ05 Three Phase — Standard Static — 4 Ton Horizontal Supply (rpm - vdc)

CFM	AVAILABLE EXTERNAL STATIC PRESSURE (in. wg)									
	0.2		0.4		0.6		0.8		1.0	
	rpm	vdc	rpm	vdc	rpm	vdc	rpm	vdc	rpm	vdc
1200	1022	5.4	1228	6.5	1417	7.5	1586	8.3	1737	9.1
1300	1074	5.7	1265	6.7	1447	7.6	1613	8.5	1762	9.3
1400	1129	5.9	1306	6.9	1479	7.8	1641	8.6	1788	9.4
1500	1186	6.2	1350	7.1	1514	8.0	1671	8.8	1816	9.6
1600	1244	6.5	1397	7.4	1553	8.2	1703	9.0	1845	9.7
1700	1304	6.9	1446	7.6	1593	8.4	1737	9.1	1875	9.9
1800	1365	7.2	1498	7.9	1636	8.6	1774	9.3	—	—
1900	1427	7.5	1552	8.2	1682	8.9	1814	9.5	—	—
2000	1490	7.8	1607	8.5	1730	9.1	1855	9.8	—	—

CFM	AVAILABLE EXTERNAL STATIC PRESSURE (in. wg)									
	1.2		1.4		1.6		1.8		2.0	
	rpm	vdc	rpm	vdc	rpm	vdc	rpm	vdc	rpm	vdc
1200	875	9.9	—	—	—	—	—	—	—	—
1300	1899	10.0	—	—	—	—	—	—	—	—
1400	—	—	—	—	—	—	—	—	—	—
1500	—	—	—	—	—	—	—	—	—	—
1600	—	—	—	—	—	—	—	—	—	—
1700	—	—	—	—	—	—	—	—	—	—
1800	—	—	—	—	—	—	—	—	—	—
1900	—	—	—	—	—	—	—	—	—	—
2000	—	—	—	—	—	—	—	—	—	—

Standard Static 1022-1900 rpm

50GCQJ05 Three Phase — Medium Static — 4 Ton Horizontal Supply (rpm - vdc)

CFM	AVAILABLE EXTERNAL STATIC PRESSURE (in. wg)									
	0.2		0.4		0.6		0.8		1.0	
	rpm	vdc	rpm	vdc	rpm	vdc	rpm	vdc	rpm	vdc
1200	1022	4.7	1228	5.7	1417	6.5	1586	7.3	1737	8.0
1300	1074	4.9	1265	5.8	1447	6.7	1613	7.4	1762	8.1
1400	1129	5.2	1306	6.0	1479	6.8	1641	7.6	1788	8.2
1500	1186	5.5	1350	6.2	1514	7.0	1671	7.7	1816	8.4
1600	1244	5.7	1397	6.4	1553	7.2	1703	7.8	1845	8.5
1700	1304	6.0	1446	6.7	1593	7.3	1737	8.0	1875	8.6
1800	1365	6.3	1498	6.9	1636	7.5	1774	8.2	1907	8.8
1900	1427	6.6	1552	7.2	1682	7.8	1814	8.4	1942	8.9
2000	1490	6.9	1607	7.4	1730	8.0	1855	8.5	1978	9.1

CFM	AVAILABLE EXTERNAL STATIC PRESSURE (in. wg)									
	1.2		1.4		1.6		1.8		2.0	
	rpm	vdc	rpm	vdc	rpm	vdc	rpm	vdc	rpm	vdc
1200	1875	8.6	2003	9.2	2123	9.8	—	—	—	—
1300	1899	8.8	2026	9.3	2145	9.9	—	—	—	—
1400	1924	8.9	2050	9.4	2169	10.0	—	—	—	—
1500	1950	9.0	2075	9.6	—	—	—	—	—	—
1600	1977	9.1	2101	9.7	—	—	—	—	—	—
1700	2005	9.2	2128	9.8	—	—	—	—	—	—
1800	2035	9.4	2156	9.9	—	—	—	—	—	—
1900	2066	9.5	—	—	—	—	—	—	—	—
2000	2099	9.7	—	—	—	—	—	—	—	—

Medium Static 1022-2170 rpm

50GCQJ05 Three Phase — High Static — 4 Ton Horizontal Supply (rpm - vdc)

CFM	AVAILABLE EXTERNAL STATIC PRESSURE (in. wg)									
	0.2		0.4		0.6		0.8		1.0	
	rpm	vdc	rpm	vdc	rpm	vdc	rpm	vdc	rpm	vdc
1200	1022	3.8	1228	4.6	1417	5.3	1586	6.0	1737	6.5
1300	1074	4.0	1265	4.8	1447	5.4	1613	6.1	1762	6.6
1400	1129	4.2	1306	4.9	1479	5.6	1641	6.2	1788	6.7
1500	1186	4.5	1350	5.1	1514	5.7	1671	6.3	1816	6.8
1600	1244	4.7	1397	5.3	1553	5.8	1703	6.4	1845	6.9
1700	1304	4.9	1446	5.4	1593	6.0	1737	6.5	1875	7.0
1800	1365	5.1	1498	5.6	1636	6.2	1774	6.7	1907	7.2
1900	1427	5.4	1552	5.8	1682	6.3	1814	6.8	1942	7.3
2000	1490	5.6	1607	6.0	1730	6.5	1855	7.0	1978	7.4

CFM	AVAILABLE EXTERNAL STATIC PRESSURE (in. wg)									
	1.2		1.4		1.6		1.8		2.0	
	rpm	vdc	rpm	vdc	rpm	vdc	rpm	vdc	rpm	vdc
1200	1875	7.0	2003	7.5	2123	8.0	2237	8.4	2345	8.8
1300	1899	7.1	2026	7.6	2145	8.1	2258	8.5	2365	8.9
1400	1924	7.2	2050	7.7	2169	8.2	2280	8.6	2387	9.0
1500	1950	7.3	2075	7.8	2193	8.2	2304	8.7	2409	9.1
1600	1977	7.4	2101	7.9	2218	8.3	2328	8.8	2433	9.1
1700	2005	7.5	2128	8.0	2243	8.4	2353	8.8	2457	9.2
1800	2035	7.7	2156	8.1	2270	8.5	2379	8.9	2482	9.3
1900	2066	7.8	2185	8.2	2298	8.6	2405	9.0	2508	9.4
2000	2099	7.9	2215	8.3	2326	8.7	2433	9.1	2535	9.5

High Static 1022-2660 rpm

50GCQT06 Single Phase — 5 Ton Horizontal Supply (rpm - bhp)

CFM	AVAILABLE EXTERNAL STATIC PRESSURE (in. wg)									
	0.2		0.4		0.6		0.8		1.0	
	rpm	bhp	rpm	bhp	rpm	bhp	rpm	bhp	rpm	bhp
1500	1197	0.18	1361	0.26	1524	0.36	1679	0.49	1822	0.62
1625	1271	0.21	1421	0.29	1574	0.40	1721	0.52	1860	0.66
1750	1347	0.25	1485	0.33	1627	0.44	1767	0.56	1901	0.70
1875	1425	0.29	1553	0.38	1684	0.49	1817	0.61	1945	0.75
2000	1504	0.35	1623	0.43	1745	0.54	1870	0.66	1992	0.80
2125	1585	0.40	1695	0.49	1809	0.60	1926	0.72	2043	0.86
2250	1666	0.47	1769	0.56	1876	0.67	1986	0.79	2096	0.93
2375	1747	0.54	1844	0.63	1945	0.74	2049	0.87	2153	1.01
2500	1830	0.62	1921	0.71	2016	0.82	2114	0.95	2213	1.09

CFM	AVAILABLE EXTERNAL STATIC PRESSURE (in. wg)									
	1.2		1.4		1.6		1.8		2.0	
	rpm	bhp	rpm	bhp	rpm	bhp	rpm	bhp	rpm	bhp
1500	1954	0.77	2078	0.92	2194	1.09	2304	1.26	—	—
1625	1990	0.81	2112	0.97	2227	1.13	2336	1.31	—	—
1750	2028	0.85	2148	1.01	2262	1.18	2370	1.36	—	—
1875	2068	0.90	2186	1.06	2298	1.23	—	—	—	—
2000	2111	0.95	2226	1.12	2336	1.29	—	—	—	—
2125	2157	1.02	2268	1.18	2375	1.36	—	—	—	—
2250	2206	1.08	2313	1.25	—	—	—	—	—	—
2375	2257	1.16	2361	1.33	—	—	—	—	—	—
2500	2312	1.24	—	—	—	—	—	—	—	—

Standard Static 1197-2150 rpm, 1.06 Max bhp

Medium Static 1197-2390 rpm, 1.44 Max bhp

50GCQT06 Single Phase — Standard Static — 5 Ton Horizontal Supply (rpm - vdc)

CFM	AVAILABLE EXTERNAL STATIC PRESSURE (in. wg)									
	0.2		0.4		0.6		0.8		1.0	
	rpm	vdc	rpm	vdc	rpm	vdc	rpm	vdc	rpm	vdc
1500	1197	5.6	1361	6.3	1524	7.1	1679	7.8	1822	8.5
1625	1271	5.9	1421	6.6	1574	7.3	1721	8.0	1860	8.7
1750	1347	6.3	1485	6.9	1627	7.6	1767	8.2	1901	8.8
1875	1425	6.6	1553	7.2	1684	7.8	1817	8.5	1945	9.0
2000	1504	7.0	1623	7.5	1745	8.1	1870	8.7	1992	9.3
2125	1585	7.4	1695	7.9	1809	8.4	1926	9.0	2043	9.5
2250	1666	7.7	1769	8.2	1876	8.7	1986	9.2	2096	9.7
2375	1747	8.1	1844	8.6	1945	9.0	2049	9.5	—	—
2500	1830	8.5	1921	8.9	2016	9.4	2114	9.8	—	—

CFM	AVAILABLE EXTERNAL STATIC PRESSURE (in. wg)									
	1.2		1.4		1.6		1.8		2.0	
	rpm	vdc	rpm	vdc	rpm	vdc	rpm	vdc	rpm	vdc
1500	1954	9.1	2078	9.7	—	—	—	—	—	—
1625	1990	9.3	2112	9.8	—	—	—	—	—	—
1750	2028	9.4	2148	10.0	—	—	—	—	—	—
1875	2068	9.6	—	—	—	—	—	—	—	—
2000	2111	9.8	—	—	—	—	—	—	—	—
2125	—	—	—	—	—	—	—	—	—	—
2250	—	—	—	—	—	—	—	—	—	—
2375	—	—	—	—	—	—	—	—	—	—
2500	—	—	—	—	—	—	—	—	—	—

Standard Static 1197-2150 rpm

50GCQT06 Single Phase — Medium Static — 5 Ton Horizontal Supply (rpm - vdc)

CFM	AVAILABLE EXTERNAL STATIC PRESSURE (in. wg)									
	0.2		0.4		0.6		0.8		1.0	
	rpm	vdc	rpm	vdc	rpm	vdc	rpm	vdc	rpm	vdc
1500	1197	5.0	1361	5.7	1524	6.4	1679	7.0	1822	7.6
1625	1271	5.3	1421	5.9	1574	6.6	1721	7.2	1860	7.8
1750	1347	5.6	1485	6.2	1627	6.8	1767	7.4	1901	8.0
1875	1425	6.0	1553	6.5	1684	7.0	1817	7.6	1945	8.1
2000	1504	6.3	1623	6.8	1745	7.3	1870	7.8	1992	8.3
2125	1585	6.6	1695	7.1	1809	7.6	1926	8.1	2043	8.5
2250	1666	7.0	1769	7.4	1876	7.8	1986	8.3	2096	8.8
2375	1747	7.3	1844	7.7	1945	8.1	2049	8.6	2153	9.0
2500	1830	7.7	1921	8.0	2016	8.4	2114	8.8	2213	9.3

CFM	AVAILABLE EXTERNAL STATIC PRESSURE (in. wg)									
	1.2		1.4		1.6		1.8		2.0	
	rpm	vdc	rpm	vdc	rpm	vdc	rpm	vdc	rpm	vdc
1500	1954	8.2	2078	8.7	2194	9.2	2304	9.6	—	—
1625	1990	8.3	2112	8.8	2227	9.3	2336	9.8	—	—
1750	2028	8.5	2148	9.0	2262	9.5	2370	9.9	—	—
1875	2068	8.7	2186	9.1	2298	9.6	—	—	—	—
2000	2111	8.8	2226	9.3	2336	9.8	—	—	—	—
2125	2157	9.0	2268	9.5	2375	9.9	—	—	—	—
2250	2206	9.2	2313	9.7	—	—	—	—	—	—
2375	2257	9.4	2361	9.9	—	—	—	—	—	—
2500	2312	9.7	—	—	—	—	—	—	—	—

Medium Static 1197-2390 rpm

50GCQJ06 Three Phase — 5 Ton Horizontal Supply (rpm - bhp)

CFM	AVAILABLE EXTERNAL STATIC PRESSURE (in. wg)									
	0.2		0.4		0.6		0.8		1.0	
	rpm	bhp	rpm	bhp	rpm	bhp	rpm	bhp	rpm	bhp
1500	1197	0.18	1361	0.26	1524	0.36	1679	0.49	1822	0.62
1625	1271	0.21	1421	0.29	1574	0.40	1721	0.52	1860	0.66
1750	1347	0.25	1485	0.33	1627	0.44	1767	0.56	1901	0.70
1875	1425	0.29	1553	0.38	1684	0.49	1817	0.61	1945	0.75
2000	1504	0.35	1623	0.43	1745	0.54	1870	0.66	1992	0.80
2125	1584	0.40	1695	0.49	1809	0.60	1926	0.72	2043	0.86
2250	1665	0.47	1769	0.56	1876	0.67	1986	0.79	2096	0.93
2375	1747	0.54	1844	0.63	1945	0.74	2049	0.87	2153	1.01
2500	1830	0.62	1921	0.71	2016	0.82	2114	0.95	2213	1.09

CFM	AVAILABLE EXTERNAL STATIC PRESSURE (in. wg)									
	1.2		1.4		1.6		1.8		2.0	
	rpm	bhp	rpm	bhp	rpm	bhp	rpm	bhp	rpm	bhp
1500	1954	0.77	2078	0.92	2194	1.09	2304	1.26	2408	1.44
1625	1990	0.81	2112	0.97	2227	1.13	2336	1.31	2439	1.49
1750	2028	0.85	2148	1.01	2262	1.18	2370	1.36	2472	1.54
1875	2068	0.90	2186	1.06	2298	1.23	2404	1.41	2506	1.60
2000	2111	0.95	2226	1.12	2336	1.29	2441	1.48	2541	1.66
2125	2157	1.02	2268	1.18	2375	1.36	2478	1.54	2578	1.73
2250	2206	1.08	2313	1.25	2417	1.43	2518	1.61	2616	1.81
2375	2257	1.16	2361	1.33	2461	1.50	2560	1.69	2655	1.89
2500	2312	1.24	2411	1.41	2508	1.59	2604	1.78	2697	1.97

- Standard Static 1197-2150 rpm, 1.06 Max bhp
- Medium Static 1197-2390 rpm, 1.44 Max bhp
- High Static 1197-2836 rpm, 2.43 Max bhp

50GCQJ06 Three Phase — Standard Static — 5 Ton Horizontal Supply (rpm - vdc)

CFM	AVAILABLE EXTERNAL STATIC PRESSURE (in. wg)									
	0.2		0.4		0.6		0.8		1.0	
	rpm	vdc	rpm	vdc	rpm	vdc	rpm	vdc	rpm	vdc
1500	1197	5.6	1361	6.3	1524	7.1	1679	7.8	1822	8.5
1625	1271	5.9	1421	6.6	1574	7.3	1721	8.0	1860	8.7
1750	1347	6.3	1485	6.9	1627	7.6	1767	8.2	1901	8.8
1875	1425	6.6	1553	7.2	1684	7.8	1817	8.5	1945	9.0
2000	1504	7.0	1623	7.5	1745	8.1	1870	8.7	1992	9.3
2125	1584	7.4	1695	7.9	1809	8.4	1926	9.0	2043	9.5
2250	1665	7.7	1769	8.2	1876	8.7	1986	9.2	2096	9.7
2375	1747	8.1	1844	8.6	1945	9.0	2049	9.5	—	—
2500	1830	8.5	1921	8.9	2016	9.4	2114	9.8	—	—

CFM	AVAILABLE EXTERNAL STATIC PRESSURE (in. wg)									
	1.2		1.4		1.6		1.8		2.0	
	rpm	vdc	rpm	vdc	rpm	vdc	rpm	vdc	rpm	vdc
1500	1954	9.1	2078	9.7	—	—	—	—	—	—
1625	1990	9.3	2112	9.8	—	—	—	—	—	—
1750	2028	9.4	2148	10.0	—	—	—	—	—	—
1875	2068	9.6	—	—	—	—	—	—	—	—
2000	2111	9.8	—	—	—	—	—	—	—	—
2125	—	—	—	—	—	—	—	—	—	—
2250	—	—	—	—	—	—	—	—	—	—
2375	—	—	—	—	—	—	—	—	—	—
2500	—	—	—	—	—	—	—	—	—	—

- Standard Static 1197-2150 rpm

50GCQJ06 Three Phase — Medium Static — 5 Ton Horizontal Supply (rpm - vdc)

CFM	AVAILABLE EXTERNAL STATIC PRESSURE (in. wg)									
	0.2		0.4		0.6		0.8		1.0	
	rpm	vdc	rpm	vdc	rpm	vdc	rpm	vdc	rpm	vdc
1500	1197	5.0	1361	5.7	1524	6.4	1679	7.0	1822	7.6
1625	1271	5.3	1421	5.9	1574	6.6	1721	7.2	1860	7.8
1750	1347	5.6	1485	6.2	1627	6.8	1767	7.4	1901	8.0
1875	1425	6.0	1553	6.5	1684	7.0	1817	7.6	1945	8.1
2000	1504	6.3	1623	6.8	1745	7.3	1870	7.8	1992	8.3
2125	1584	6.6	1695	7.1	1809	7.6	1926	8.1	2043	8.5
2250	1665	7.0	1769	7.4	1876	7.8	1986	8.3	2096	8.8
2375	1747	7.3	1844	7.7	1945	8.1	2049	8.6	2153	9.0
2500	1830	7.7	1921	8.0	2016	8.4	2114	8.8	2213	9.3

CFM	AVAILABLE EXTERNAL STATIC PRESSURE (in. wg)									
	1.2		1.4		1.6		1.8		2.0	
	rpm	vdc	rpm	vdc	rpm	vdc	rpm	vdc	rpm	vdc
1500	1954	8.2	2078	8.7	2194	9.2	2304	9.6	—	—
1625	1990	8.3	2112	8.8	2227	9.3	2336	9.8	—	—
1750	2028	8.5	2148	9.0	2262	9.5	2370	9.9	—	—
1875	2068	8.7	2186	9.1	2298	9.6	—	—	—	—
2000	2111	8.8	2226	9.3	2336	9.8	—	—	—	—
2125	2157	9.0	2268	9.5	2375	9.9	—	—	—	—
2250	2206	9.2	2313	9.7	—	—	—	—	—	—
2375	2257	9.4	2361	9.9	—	—	—	—	—	—
2500	2312	9.7	—	—	—	—	—	—	—	—

Medium Static 1197-2390 rpm

50GCQJ06 Three Phase — High Static — 5 Ton Horizontal Supply (rpm - vdc)

CFM	AVAILABLE EXTERNAL STATIC PRESSURE (in. wg)									
	0.2		0.4		0.6		0.8		1.0	
	rpm	vdc	rpm	vdc	rpm	vdc	rpm	vdc	rpm	vdc
1500	1197	4.2	1361	4.8	1524	5.4	1679	5.9	1822	6.4
1625	1271	4.5	1421	5.0	1574	5.6	1721	6.1	1860	6.6
1750	1347	4.7	1485	5.2	1627	5.7	1767	6.2	1901	6.7
1875	1425	5.0	1553	5.5	1684	5.9	1817	6.4	1945	6.9
2000	1504	5.3	1623	5.7	1745	6.2	1870	6.6	1992	7.0
2125	1584	5.6	1695	6.0	1809	6.4	1926	6.8	2043	7.2
2250	1665	5.9	1769	6.2	1876	6.6	1986	7.0	2096	7.4
2375	1747	6.2	1844	6.5	1945	6.9	2049	7.2	2153	7.6
2500	1830	6.5	1921	6.8	2016	7.1	2114	7.5	2213	7.8

CFM	AVAILABLE EXTERNAL STATIC PRESSURE (in. wg)									
	1.2		1.4		1.6		1.8		2.0	
	rpm	vdc	rpm	vdc	rpm	vdc	rpm	vdc	rpm	vdc
1500	1954	6.9	2078	7.3	2194	7.7	2304	8.1	2408	8.5
1625	1990	7.0	2112	7.4	2227	7.9	2336	8.2	2439	8.6
1750	2028	7.2	2148	7.6	2262	8.0	2370	8.4	2472	8.7
1875	2068	7.3	2186	7.7	2298	8.1	2404	8.5	2506	8.8
2000	2111	7.4	2226	7.8	2336	8.2	2441	8.6	2541	9.0
2125	2157	7.6	2268	8.0	2375	8.4	2478	8.7	2578	9.1
2250	2206	7.8	2313	8.2	2417	8.5	2518	8.9	2616	9.2
2375	2257	8.0	2361	8.3	2461	8.7	2560	9.0	2655	9.4
2500	2312	8.2	2411	8.5	2508	8.8	2604	9.2	2697	9.5

High Static 1197-2836 rpm

Legend and Notes

Applicable for Electrical Data Tables on pages 56-76

LEGEND

BRKR	— Circuit Breaker
C.O.	— Convenience Outlet
FLA	— Full Load Amps
IFM	— Indoor Fan Motor
LRA	— Locked Rotor Amps
MCA	— Minimum Circuit Amps
P.E.	— Power Exhaust
Pwr'd fr/unit	— Powered From Unit
PWRD C.O.	— Powered Convenience Outlet
RLA	— Rated Load Amps
UNPWR C.O.	— Unpowered Convenience Outlet

NOTES:

1. In compliance with NEC requirements for multi-motor and combination load equipment (refer to NEC Articles 430 and 440), the overcurrent protective device for the unit shall be fuse or HACR breaker. Canadian units may be fuse or circuit breaker.
2. For 208/230 v units, where one value is show it is the same for either 208 or 230 volts.
3. Unbalanced 3-Phase Supply Voltage: Never operate a motor where a phase imbalance in supply voltage is greater than 2%. Use the following formula to determine the percentage of voltage imbalance.

$$\% \text{ Voltage Imbalance} = 100 \times \frac{\text{max voltage deviation from average voltage}}{\text{average voltage}}$$

Example: Supply voltage is 230-3-60

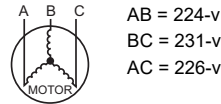

$$\text{Average Voltage} = \frac{(224 + 231 + 226)}{3} = \frac{681}{3} = 227$$

Determine maximum deviation from average voltage.

$$(AB) 227-224 = 3\text{-v}$$

$$(BC) 231-227 = 4\text{-v}$$

$$(AC) 227-226 = 1\text{-v}$$

Maximum deviation is 4-v.

Determine percent of voltage imbalance.

$$\% \text{ Voltage Imbalance} = 100 \times \frac{4}{227} = 1.76\%$$

This amount of phase imbalance is satisfactory as it is below the maximum allowable 2%.

IMPORTANT: If the supply voltage phase imbalance is more than 2%, contact your local electric utility company immediately.

50GCQ*04-06 Cooling Electrical Data

50GCQ UNIT	V-Ph-Hz	UNIT VOLTAGE		COMPRESSOR		OFM (EA)		IFM			POWER EXHAUST	
		Range		RLA	LRA	Watts	FLA	Type	Efficiency at Full Load	FLA	Kit Qty	FLA (EA Kit)
		Min	Max									
*04	208/230-1-60	187	253	15.4	92	275	1.0	STD	84%	3.4	1	1.9
						275	1.0	MED	84%	5.1		
						275	1.0	HIGH	85%	7.3		
	208/230-3-60	187	253	10.1	88	275	1.0	STD	84%	3.4	1	1.9
						275	1.0	MED	84%	5.1		
						275	1.0	HIGH	85%	7.3		
	460-3-60	414	506	4.7	44	275	0.6	STD	85%	0.9	1	1.0
						275	0.6	MED	85%	1.2		
						275	0.6	HIGH	84%	1.5		
	575-3-60	518	633	3.8	29	275	0.5	STD	84%	0.8	1	1.9
						275	0.5	MED	84%	1.1		
						275	0.5	HIGH	85%	1.5		
*05	208/230-1-60	187	253	24.1	127	275	1.3	STD	87%	5.0	1	1.9
						275	1.3	MED	86%	7.1		
						275	1.3	HIGH	84%	8.8		
	208/230-3-60	187	253	14.6	105	275	1.3	STD	87%	5.0	1	1.9
						275	1.3	MED	86%	7.1		
						275	1.3	HIGH	85%	5.1		
	460-3-60	414	506	7.7	62	275	0.8	STD	85%	1.2	1	1.0
						275	0.8	MED	86%	1.5		
						275	0.8	HIGH	88%	2.4		
	575-3-60	518	633	5.0	39	275	0.6	STD	84%	1.1	1	1.9
						275	0.6	MED	85%	1.5		
						275	0.6	HIGH	88%	2.1		
*06	208/230-1-60	187	253	30.1	158	275	1.3	STD	86%	7.2	1	1.9
						275	1.3	MED	84%	8.6		
						275	1.3	HIGH	84%	6.4		
	208/230-3-60	187	253	17.5	110	275	1.3	STD	86%	7.2	1	1.9
						275	1.3	MED	84%	8.6		
						275	1.3	HIGH	84%	6.4		
	460-3-60	414	506	8.0	55	275	0.8	STD	86%	1.5	1	1.0
						275	0.8	MED	86%	1.9		
						275	0.8	HIGH	88%	2.9		
	575-3-60	518	633	6.7	48	275	0.6	STD	84%	1.5	1	1.9
						275	0.6	MED	85%	1.8		
						275	0.6	HIGH	87%	2.5		

50GCQ*04 MCA MOCPS Electrical Data

50GCQ UNIT SIZE	NOM. V-Ph-Hz	IFM TYPE	ELECTRIC HEATER			NO CONVENIENCE OUTLET OR UNPOWERED CONVENIENCE OUTLET							
			CRHEATER ****00	Nom (kW)	FLA	No Power Exhaust				With Power Exhaust (powered from unit)			
						MCA	Fuse or HACR Brkr	Disconnect Size		MCA	Fuse or HACR Brkr	Disconnect Size	
								FLA	LRA			FLA	LRA
T04	208/230-1-60	STD	None	—	—	24	30	23	99	26	30	25	101
			323A	3.3/4.4	15.9/18.3	44/47	50/50	41/44	115/117	46/49	50/50	43/46	117/119
			324A	4.9/6.5	23.5/27.1	53/58	60/60	50/54	123/126	55/60	60/60	52/56	125/128
			325A	6.5/8.7	31.4/36.3	63/69	70/70	59/65	130/135	65/71	70/80	61/67	132/137
			326A	7.9/10.5	37.9/43.8	71/79	80/80	66/73	137/143	73/81	80/90	69/75	139/145
		327A	9.8/13.0	46.9/54.2	83/92	90/100	77/85	146/153	85/94	90/100	79/87	148/155	
		MED	None	—	—	26	30	25	101	28	40	27	103
			323A	3.3/4.4	15.9/18.3	46/49	50/50	43/46	117/119	48/51	50/60	45/48	119/121
			324A	4.9/6.5	23.5/27.1	55/60	60/60	52/56	125/128	57/62	60/70	54/58	127/130
			325A	6.5/8.7	31.4/36.3	65/71	70/80	61/66	132/137	67/73	70/80	63/69	134/139
			326A	7.9/10.5	37.9/43.8	73/81	80/90	68/75	139/145	75/82	80/90	70/77	141/147
		327A	9.8/13.0	46.9/54.2	84/94	90/100	79/87	148/155	86/95	90/100	81/89	150/157	
		HIGH	None	—	—	28	40	27	104	30	40	29	106
			323A	3.3/4.4	15.9/18.3	48/51	50/60	46/48	120/122	50/53	60/60	48/50	122/124
			324A	4.9/6.5	23.5/27.1	57/62	60/70	54/58	128/131	59/64	60/70	56/61	130/133
			325A	6.5/8.7	31.4/36.3	67/73	70/80	63/69	135/140	69/75	70/80	66/71	137/142
			326A	7.9/10.5	37.9/43.8	75/83	80/90	71/78	142/148	77/85	80/90	73/80	144/150
		327A	9.8/13.0	46.9/54.2	87/96	90/100	81/90	151/158	89/98	90/100	83/92	153/160	
208/230-3-60	STD	None	—	—	17	25	17	95	19	25	19	97	
		323A	3.3/4.4	9.2/10.6	29/31	30/35	27/29	104/106	31/33	35/35	29/31	106/108	
		324A	4.9/6.5	13.6/15.6	34/37	40/40	32/35	109/111	36/39	40/40	35/37	111/113	
		325A	6.5/8.7	18.1/20.9	40/44	45/45	37/41	113/116	42/46	45/50	40/43	115/118	
		326A	7.9/10.5	21.9/25.3	45/49	45/50	42/46	117/120	47/51	50/60	44/48	119/122	
	328A	12.0/16.0	33.4/38.5	59/66	60/70	55/61	128/134	61/68	70/70	57/63	130/136		
	MED	None	—	—	19	25	19	97	21	30	21	99	
		323A	3.3/4.4	9.2/10.6	31/32	35/35	29/31	106/108	33/34	35/40	31/33	108/110	
		324A	4.9/6.5	13.6/15.6	36/39	40/40	34/37	111/113	38/41	40/45	36/39	113/115	
		325A	6.5/8.7	18.1/20.9	42/45	45/45	39/43	115/118	44/47	45/50	42/45	117/120	
		326A	7.9/10.5	21.9/25.3	47/51	50/60	44/48	119/122	48/53	50/60	46/50	121/124	
	328A	12.0/16.0	33.4/38.5	61/67	70/70	57/63	130/136	63/69	70/70	59/65	132/138		
	HIGH	None	—	—	21	30	21	100	23	30	23	102	
		323A	3.3/4.4	9.2/10.6	33/35	40/40	32/33	109/111	35/37	40/40	34/36	111/113	
		324A	4.9/6.5	13.6/15.6	38/41	40/45	37/39	114/116	40/43	45/45	39/41	116/118	
		325A	6.5/8.7	18.1/20.9	44/48	45/50	42/45	118/121	46/49	50/50	44/47	120/123	
		326A	7.9/10.5	21.9/25.3	49/53	50/60	46/50	122/125	51/55	60/60	49/52	124/127	
	328A	12.0/16.0	33.4/38.5	63/70	70/70	60/65	133/139	65/71	70/80	62/68	135/141		
J04	460-3-60	STD	None	—	—	8	15	7	46	9	15	8	47
			333A	6.0	7.2	17	20	15	53	18	20	17	54
			334A	8.8	10.6	21	25	19	57	22	25	20	58
			335A	11.5	13.8	25	25	23	60	26	30	24	61
		336A	14.0	16.8	29	30	26	63	30	30	28	64	
		MED	None	—	—	8	15	7	47	9	15	9	48
			333A	6.0	7.2	17	20	16	54	18	20	17	55
			334A	8.8	10.6	21	25	20	58	22	25	21	59
			335A	11.5	13.8	25	25	23	61	26	30	24	62
	336A	14.0	16.8	29	30	27	64	30	30	28	65		
	HIGH	None	—	—	8	15	8	47	9	15	9	48	
		333A	6.0	7.2	17	20	16	54	18	20	17	55	
		334A	8.8	10.6	22	25	20	58	23	25	21	59	
		335A	11.5	13.8	26	30	24	61	27	30	25	62	
	336A	14.0	16.8	29	30	27	64	30	30	28	65		
	575-3-60	STD	None	—	—	7	15	6	31	8	15	8	33
			339A	10.0	9.6	19	20	17	41	20	20	19	43
			340A	15.0	14.4	25	25	22	45	26	30	25	47
MED		None	—	—	7	15	6	32	9	15	8	34	
		339A	10.0	9.6	19	20	17	42	21	25	19	44	
		340A	15.0	14.4	25	25	23	46	27	30	25	48	
HIGH		None	—	—	7	15	7	32	9	15	9	34	
		339A	10.0	9.6	19	20	18	42	21	25	20	44	
		340A	15.0	14.4	25	25	23	46	27	30	25	48	

50GCQ*04 MCA MOCPP Electrical Data (cont)

50GCQ UNIT SIZE	NOM. V-Ph-Hz	IFM TYPE	ELECTRIC HEATER			WITH POWERED CONVENIENCE OUTLET							
			CRHEATER ****00	Nom (kW)	FLA	No Power Exhaust				With Power Exhaust (powered from unit)			
						MCA	Fuse or HACR Brkr	Disconnect Size		MCA	Fuse or HACR Brkr	Disconnect Size	
								FLA	LRA			FLA	LRA
J04	208/230-3-60	STD	None	—	—	22	30	22	100	24	30	24	102
			323A	3.3/4.4	9.2/10.6	34/36	40/40	33/34	109/111	36/37	40/40	35/37	111/113
			324A	4.9/6.5	13.6/15.6	39/42	45/45	38/40	114/116	41/44	45/45	40/42	116/118
			325A	6.5/8.7	18.1/20.9	45/48	50/50	43/46	118/121	47/50	50/50	45/48	120/123
			326A	7.9/10.5	21.9/25.3	50/54	50/60	47/51	122/125	52/56	60/60	50/53	124/127
			328A	12.0/16.0	33.4/38.5	64/70	70/70	61/66	133/139	66/72	70/80	63/69	135/141
		MED	None	—	—	24	30	24	102	26	30	26	104
			323A	3.3/4.4	9.2/10.6	35/37	40/40	35/36	111/113	37/39	40/45	37/39	113/115
			324A	4.9/6.5	13.6/15.6	41/43	45/45	40/42	116/118	43/45	45/50	42/44	118/120
			325A	6.5/8.7	18.1/20.9	47/50	50/50	45/48	120/123	49/52	50/60	47/50	122/125
			326A	7.9/10.5	21.9/25.3	51/56	60/60	49/53	124/127	53/58	60/60	52/55	126/129
			328A	12.0/16.0	33.4/38.5	66/72	70/80	63/68	135/141	68/74	70/80	65/71	137/143
		HIGH	None	—	—	26	30	27	105	28	35	29	107
			323A	3.3/4.4	9.2/10.6	38/39	45/45	37/39	114/116	40/41	45/45	39/41	116/118
			324A	4.9/6.5	13.6/15.6	43/46	45/50	42/45	119/121	45/48	50/50	45/47	121/123
			325A	6.5/8.7	18.1/20.9	49/52	50/60	47/51	123/126	51/54	60/60	50/53	125/128
			326A	7.9/10.5	21.9/25.3	54/58	60/60	52/56	127/130	55/60	60/60	54/58	129/132
			328A	12.0/16.0	33.4/38.5	68/74	70/80	65/71	138/144	70/76	70/80	67/73	140/146
	460-3-60	STD	None	—	—	10	15	10	48	11	15	11	49
			333A	6.0	7.2	19	20	18	55	20	20	19	56
			334A	8.8	10.6	23	25	22	59	24	25	23	60
			335A	11.5	13.8	27	30	26	62	28	30	27	63
			336A	14.0	16.8	31	35	29	65	32	35	30	66
			None	—	—	10	15	10	49	11	15	11	50
		MED	333A	6.0	7.2	19	20	18	56	20	20	19	57
			334A	8.8	10.6	24	25	22	60	25	25	23	61
			335A	11.5	13.8	28	30	26	63	29	30	27	64
336A			14.0	16.8	31	35	29	66	32	35	30	67	
None			—	—	11	15	10	49	12	15	12	50	
333A			6.0	7.2	20	20	19	56	21	25	20	57	
HIGH		334A	8.8	10.6	24	25	23	60	25	25	24	61	
		335A	11.5	13.8	28	30	26	63	29	30	27	64	
		336A	14.0	16.8	32	35	30	66	33	35	31	67	
		None	—	—	8	15	8	33	10	15	10	35	
		339A	10.0	9.6	20	20	19	43	22	25	21	45	
		340A	15.0	14.4	26	30	24	47	28	30	27	49	
575-3-60	STD	None	—	—	9	15	8	34	10	15	10	36	
		339A	10.0	9.6	21	25	19	44	22	25	21	46	
		340A	15.0	14.4	27	30	25	48	28	30	27	50	
	MED	None	—	—	9	15	9	34	11	15	11	36	
		339A	10.0	9.6	21	25	20	44	23	25	22	46	
		340A	15.0	14.4	27	30	25	48	29	30	27	50	
HIGH	None	—	—	9	15	9	34	11	15	11	36		
	339A	10.0	9.6	21	25	20	44	23	25	22	46		
	340A	15.0	14.4	27	30	25	48	29	30	27	50		

50GCQ*04 MCA MOCP Electrical Data — with Factory-Installed HACR Breaker

50GCQ UNIT SIZE	NOM. V-Ph-Hz	IFM TYPE	ELECTRIC HEATER			NO CONVENIENCE OUTLET OR UNPOWERED CONVENIENCE OUTLET									
			CRHEATER ****00	Nom (kW)	FLA	No Power Exhaust				With Power Exhaust (powered from unit)					
						MCA	Fuse or HACR Brkr	Disconnect Size		MCA	Fuse or HACR Brkr	Disconnect Size			
								FLA	LRA			FLA	LRA		
T04	208/230-1-60	STD	None	—	—	24	30	23	99	26	30	25	101		
			323A	3.3/4.4	15.9/18.3	47/47	50/50	41/44	115/117	49/49	50/50	43/46	117/119		
			324A	4.9/6.5	23.5/27.1	58/58	60/60	50/54	123/126	60/60	60/60	52/56	125/128		
			325A	6.5/8.7	31.4/36.3	69/69	70/70	59/65	130/135	71/71	80/80	61/67	132/137		
			326A	7.9/10.5	37.9/43.8	79/79	80/80	66/73	137/143	81/81	90/90	69/75	139/145		
		327A	9.8/13.0	46.9/54.2	92/92	100/100	77/85	146/153	94/94	100/100	79/87	148/155			
		MED	None	—	—	26	30	25	101	28	40	27	103		
			323A	3.3/4.4	15.9/18.3	49/49	50/50	43/46	117/119	51/51	60/60	45/48	119/121		
			324A	4.9/6.5	23.5/27.1	60/60	60/60	52/56	125/128	62/62	70/70	54/58	127/130		
			325A	6.5/8.7	31.4/36.3	71/71	80/80	61/66	132/137	73/73	80/80	63/69	134/139		
			326A	7.9/10.5	37.9/43.8	81/81	90/90	68/75	139/145	82/82	90/90	70/77	141/147		
		327A	9.8/13.0	46.9/54.2	94/94	100/100	79/87	148/155	95/95	100/100	81/89	150/157			
		HIGH	None	—	—	28	40	27	104	30	40	29	106		
			323A	3.3/4.4	15.9/18.3	51/51	60/60	46/48	120/122	53/53	60/60	48/50	122/124		
			324A	4.9/6.5	23.5/27.1	62/62	70/70	54/58	128/131	64/64	70/70	56/61	130/133		
			325A	6.5/8.7	31.4/36.3	73/73	80/80	63/69	135/140	75/75	80/80	66/71	137/142		
			326A	7.9/10.5	37.9/43.8	83/83	90/90	71/78	142/148	85/85	90/90	73/80	144/150		
		327A	9.8/13.0	46.9/54.2	96/96	100/100	81/90	151/158	98/98	100/100	83/92	153/160			
T04	208/230-3-60	STD	None	—	—	17	25	17	95	19	25	19	97		
			323A	3.3/4.4	9.2/10.6	31/31	35/35	27/29	104/106	33/33	35/35	29/31	106/108		
			324A	4.9/6.5	13.6/15.6	37/37	40/40	32/35	109/111	39/39	40/40	35/37	111/113		
			325A	6.5/8.7	18.1/20.9	44/44	45/45	37/41	113/116	46/46	50/50	40/43	115/118		
			326A	7.9/10.5	21.9/25.3	49/49	50/50	42/46	117/120	51/51	60/60	44/48	119/122		
		328A	12.0/16.0	33.4/38.5	66/66	70/70	55/61	128/134	68/68	70/70	57/63	130/136			
		MED	None	—	—	19	25	19	97	21	30	21	99		
			323A	3.3/4.4	9.2/10.6	32/32	35/35	29/31	106/108	34/34	40/40	31/33	108/110		
			324A	4.9/6.5	13.6/15.6	39/39	40/40	34/37	111/113	41/41	45/45	36/39	113/115		
			325A	6.5/8.7	18.1/20.9	45/45	45/45	39/43	115/118	47/47	50/50	42/45	117/120		
			326A	7.9/10.5	21.9/25.3	51/51	60/60	44/48	119/122	53/53	60/60	46/50	121/124		
		328A	12.0/16.0	33.4/38.5	67/67	70/70	57/63	130/136	69/69	70/70	59/65	132/138			
		HIGH	None	—	—	21	30	21	100	23	30	23	102		
			323A	3.3/4.4	9.2/10.6	35/35	40/40	32/33	109/111	37/37	40/40	34/36	111/113		
			324A	4.9/6.5	13.6/15.6	41/41	45/45	37/39	114/116	43/43	45/45	39/41	116/118		
			325A	6.5/8.7	18.1/20.9	48/48	50/50	42/45	118/121	49/49	50/50	44/47	120/123		
			326A	7.9/10.5	21.9/25.3	53/53	60/60	46/50	122/125	55/55	60/60	49/52	124/127		
		328A	12.0/16.0	33.4/38.5	70/70	70/70	60/65	133/139	71/71	80/80	62/68	135/141			
J04	460-3-60	STD	None	—	—	8	15	7	46	9	15	8	47		
			333A	6.0	7.2	17	20	15	53	18	20	17	54		
			334A	8.8	10.6	21	25	19	57	22	25	20	58		
			335A	11.5	13.8	25	25	23	60	26	30	24	61		
			336A	14.0	16.8	29	30	26	63	30	30	28	64		
		MED	None	—	—	8	15	7	47	9	15	9	48		
			333A	6.0	7.2	17	20	16	54	18	20	17	55		
			334A	8.8	10.6	21	25	20	58	22	25	21	59		
			335A	11.5	13.8	25	25	23	61	26	30	24	62		
			336A	14.0	16.8	29	30	27	64	30	30	28	65		
		HIGH	None	—	—	8	15	8	47	9	15	9	48		
			333A	6.0	7.2	17	20	16	54	18	20	17	55		
			334A	8.8	10.6	22	25	20	58	23	25	21	59		
			335A	11.5	13.8	26	30	24	61	27	30	25	62		
			336A	14.0	16.8	29	30	27	64	30	30	28	65		
		J04	575-3-60	STD	None	—	—	7	15	6	31	8	15	8	33
					339A	10.0	9.6	19	20	17	41	20	20	19	43
					340A	15.0	14.4	25	25	22	45	26	30	25	47
MED	None			—	—	7	15	6	32	9	15	8	34		
	339A			10.0	9.6	19	20	17	42	21	25	19	44		
	340A			15.0	14.4	25	25	23	46	27	30	25	48		
HIGH	None			—	—	7	15	7	32	9	15	9	34		
	339A			10.0	9.6	19	20	18	42	21	25	20	44		
	340A			15.0	14.4	25	25	23	46	27	30	25	48		
	340A			15.0	14.4	25	25	23	46	27	30	25	48		

Electrical data (cont)



50GCQ*04 MCA MOCP Electrical Data — with Factory-Installed HACR Breaker (cont)

50GCQ UNIT SIZE	NOM. V-Ph-Hz	IFM TYPE	ELECTRIC HEATER			WITH POWERED CONVENIENCE OUTLET							
			CRHEATER ****00	Nom (kW)	FLA	No Power Exhaust				With Power Exhaust (powered from unit)			
						MCA	Fuse or HACR Brkr	Disconnect Size		MCA	Fuse or HACR Brkr	Disconnect Size	
								FLA	LRA			FLA	LRA
J04	208/230-3-60	STD	None	—	—	22	30	22	100	24	30	24	102
			323A	3.3/4.4	9.2/10.6	36/36	40/40	33/34	109/111	37/37	40/40	35/37	111/113
			324A	4.9/6.5	13.6/15.6	42/42	45/45	38/40	114/116	44/44	45/45	40/42	116/118
			325A	6.5/8.7	18.1/20.9	48/48	50/50	43/46	118/121	50/50	50/50	45/48	120/123
			326A	7.9/10.5	21.9/25.3	54/54	60/60	47/51	122/125	56/56	60/60	50/53	124/127
			328A	12.0/16.0	33.4/38.5	70/70	70/70	61/66	133/139	72/72	80/80	63/69	135/141
		MED	None	—	—	24	30	24	102	26	30	26	104
			323A	3.3/4.4	9.2/10.6	37/37	40/40	35/36	111/113	39/39	45/45	37/39	113/115
			324A	4.9/6.5	13.6/15.6	43/43	45/45	40/42	116/118	45/45	50/50	42/44	118/120
			325A	6.5/8.7	18.1/20.9	50/50	50/50	45/48	120/123	52/52	60/60	47/50	122/125
			326A	7.9/10.5	21.9/25.3	56/56	60/60	49/53	124/127	58/58	60/60	52/55	126/129
			328A	12.0/16.0	33.4/38.5	72/72	80/80	63/68	135/141	74/74	80/80	65/71	137/143
		HIGH	None	—	—	26	30	27	105	28	35	29	107
			323A	3.3/4.4	9.2/10.6	39/39	45/45	37/39	114/116	41/41	45/45	39/41	116/118
			324A	4.9/6.5	13.6/15.6	46/46	50/50	42/45	119/121	48/48	50/50	45/47	121/123
			325A	6.5/8.7	18.1/20.9	52/52	60/60	47/51	123/126	54/54	60/60	50/53	125/128
			326A	7.9/10.5	21.9/25.3	58/58	60/60	52/56	127/130	60/60	60/60	54/58	129/132
			328A	12.0/16.0	33.4/38.5	74/74	80/80	65/71	138/144	76/76	80/80	67/73	140/146
	460-3-60	STD	None	—	—	10	15	10	48	11	15	11	49
			333A	6.0	7.2	19	20	18	55	20	20	19	56
			334A	8.8	10.6	23	25	22	59	24	25	23	60
			335A	11.5	13.8	27	30	26	62	28	30	27	63
			336A	14.0	16.8	31	35	29	65	32	35	30	66
			None	—	—	10	15	10	49	11	15	11	50
		MED	333A	6.0	7.2	19	20	18	56	20	20	19	57
			334A	8.8	10.6	24	25	22	60	25	25	23	61
			335A	11.5	13.8	28	30	26	63	29	30	27	64
336A			14.0	16.8	31	35	29	66	32	35	30	67	
None			—	—	11	15	10	49	12	15	12	50	
333A			6.0	7.2	20	20	19	56	21	25	20	57	
HIGH		334A	8.8	10.6	24	25	23	60	25	25	24	61	
		335A	11.5	13.8	28	30	26	63	29	30	27	64	
		336A	14.0	16.8	32	35	30	66	33	35	31	67	
		None	—	—	8	15	8	33	10	15	10	35	
		339A	10.0	9.6	20	20	19	43	22	25	21	45	
		340A	15.0	14.4	26	30	24	47	28	30	27	49	
575-3-60	STD	None	—	—	9	15	8	34	10	15	10	36	
		339A	10.0	9.6	21	25	19	44	22	25	21	46	
		340A	15.0	14.4	27	30	25	48	28	30	27	50	
	MED	None	—	—	9	15	9	34	11	15	11	36	
		339A	10.0	9.6	21	25	20	44	23	25	22	46	
		340A	15.0	14.4	27	30	25	48	29	30	27	50	
	HIGH	None	—	—	9	15	9	34	11	15	11	36	
		339A	10.0	9.6	21	25	20	44	23	25	22	46	
		340A	15.0	14.4	27	30	25	48	29	30	27	50	

50GCQ*05 MCA MOCPP Electrical Data

50GCQ UNIT SIZE	NOM. V-Ph-Hz	IFM TYPE	ELECTRIC HEATER			NO CONVENIENCE OUTLET OR UNPOWERED CONVENIENCE OUTLET							
			CRHEATER ****00	Nom (kW)	FLA	No Power Exhaust				With Power Exhaust (powered from unit)			
						MCA	Fuse or HACR Brkr	Disconnect Size		MCA	Fuse or HACR Brkr	Disconnect Size	
								FLA	LRA			FLA	LRA
T05	208/230-1-60	STD	None	—	—	37	60	35	137	39	60	37	139
			323A	3.3/4.4	15.9/18.3	57/60	60/70	53/56	153/155	59/62	70/80	55/58	155/157
			325A	6.5/8.7	31.4/36.3	76/82	80/90	71/77	168/173	78/84	80/90	73/79	170/175
			327A	9.8/13.0	46.9/54.2	96/105	100/110	89/97	184/191	97/107	100/110	91/99	186/193
			329A	13.1/17.4	62.8/72.5	115/128	125/150	107/118	200/210	117/129	125/150	109/121	202/212
			330A	14.4/19.2	69.3/80.0	124/137	125/150	115/127	206/217	125/139	125/150	117/129	208/219
		331A	15.8/21.0	75.8/87.5	132/146	150/150	122/136	213/225	134/148	150/150	124/138	215/227	
		326A	7.9/10.5	37.9/43.8	84/92	90/100	79/85	175/181	86/94	100/100	81/88	177/183	
		MED	None	—	—	39	60	37	140	41	60	40	142
			323A	3.3/4.4	15.9/18.3	59/62	70/80	56/58	156/158	61/64	80/80	58/61	158/160
			325A	6.5/8.7	31.4/36.3	78/84	80/90	73/79	171/176	80/86	80/100	76/81	173/178
			327A	9.8/13.0	46.9/54.2	98/107	100/110	91/100	187/194	100/109	100/110	93/102	189/196
			329A	13.1/17.4	62.8/72.5	117/130	125/150	110/121	203/213	119/132	125/150	112/123	205/215
			330A	14.4/19.2	69.3/80.0	126/139	150/150	117/129	209/220	128/141	150/150	119/132	211/222
		331A	15.8/21.0	75.8/87.5	134/148	150/150	125/138	216/228	136/150	150/150	127/140	218/230	
		326A	7.9/10.5	37.9/43.8	86/94	100/100	81/88	178/184	88/96	100/100	83/90	180/186	
		HIGH	None	—	—	41	60	39	142	43	60	42	144
			323A	3.3/4.4	15.9/18.3	61/64	80/80	58/60	158/160	62/65	80/80	60/63	160/162
			325A	6.5/8.7	31.4/36.3	80/86	80/100	75/81	173/178	82/88	90/100	78/83	175/180
			327A	9.8/13.0	46.9/54.2	99/108	100/110	93/102	189/196	101/110	110/110	95/104	191/198
			329A	13.1/17.4	62.8/72.5	119/131	125/150	112/123	205/215	121/133	125/150	114/125	207/217
			330A	14.4/19.2	69.3/80.0	127/141	150/150	119/131	211/222	129/143	150/150	121/134	213/224
		331A	15.8/21.0	75.8/87.5	135/150	150/150	127/140	218/230	137/152	150/175	129/142	220/232	
		326A	7.9/10.5	37.9/43.8	88/95	100/100	83/90	180/186	90/97	100/100	85/92	182/188	
J05	208/230-3-60	STD	None	—	—	25	30	24	115	27	40	26	117
			323A	3.3/4.4	9.2/10.6	37/38	45/45	35/36	124/126	38/40	50/50	37/38	126/128
			324A	4.9/6.5	13.6/15.6	42/45	50/50	40/42	129/131	44/46	50/50	42/44	131/133
			325A	6.5/8.7	18.1/20.9	48/51	50/60	45/48	133/136	50/53	50/60	47/50	135/138
			328A	12.0/16.0	33.4/38.5	67/73	70/80	62/68	148/154	69/75	70/80	65/70	150/156
			330A	14.4/19.2	40.0/46.2	75/83	80/90	70/77	155/161	77/85	80/90	72/79	157/163
		331A	15.8/21.0	43.8/50.5	80/88	80/90	74/82	159/166	82/90	90/90	77/84	161/168	
		326A	7.9/10.5	21.9/25.3	52/57	60/60	49/53	137/140	54/59	60/60	51/55	139/142	
		MED	None	—	—	27	40	26	118	29	40	29	120
			323A	3.3/4.4	9.2/10.6	39/40	50/50	37/39	127/129	41/42	50/50	39/41	129/131
			324A	4.9/6.5	13.6/15.6	44/47	50/50	42/44	132/134	46/49	50/50	44/47	134/136
			325A	6.5/8.7	18.1/20.9	50/53	50/60	47/50	136/139	52/55	60/60	49/53	138/141
			328A	12.0/16.0	33.4/38.5	69/75	70/80	65/71	151/157	71/77	80/80	67/73	153/159
			330A	14.4/19.2	40.0/46.2	77/85	80/90	72/80	158/164	79/87	80/90	75/82	160/166
		331A	15.8/21.0	43.8/50.5	82/90	90/90	77/85	162/169	84/92	90/100	79/87	164/171	
		326A	7.9/10.5	21.9/25.3	54/59	60/60	52/56	140/143	56/61	60/70	54/58	142/145	
		HIGH	None	—	—	25	30	24	115	27	40	26	117
			323A	3.3/4.4	9.2/10.6	37/38	45/45	35/36	124/126	39/40	50/50	37/39	126/128
			324A	4.9/6.5	13.6/15.6	42/45	50/50	40/42	129/131	44/47	50/50	42/44	131/133
			325A	6.5/8.7	18.1/20.9	48/51	50/60	45/48	133/136	50/53	50/60	47/50	135/138
			328A	12.0/16.0	33.4/38.5	67/73	70/80	63/68	148/154	69/75	70/80	65/71	150/156
			330A	14.4/19.2	40.0/46.2	75/83	80/90	70/77	155/161	77/85	80/90	72/79	157/163
		331A	15.8/21.0	43.8/50.5	80/88	80/90	75/82	159/166	82/90	90/90	77/84	161/168	
		326A	7.9/10.5	21.9/25.3	52/57	60/60	49/53	137/140	54/59	60/60	52/55	139/142	
J05	460-3-60	STD	None	—	—	12	15	11	65	13	20	12	66
			333A	6.0	7.2	21	25	19	72	22	25	21	73
			335A	11.5	13.8	29	30	27	79	30	30	28	80
			336A	14.0	16.8	33	35	30	82	34	35	32	83
		337A	21.5	25.9	44	45	41	91	45	45	42	92	
		MED	None	—	—	12	15	12	65	13	20	13	66
			333A	6.0	7.2	21	25	20	72	22	25	21	73
			335A	11.5	13.8	30	30	27	79	31	35	29	80
			336A	14.0	16.8	33	35	31	82	34	35	32	83
		337A	21.5	25.9	45	45	41	91	46	50	42	92	

50GCQ*05 MCA MOC P Electrical Data (cont)

50GCQ UNIT SIZE	NOM. V-Ph-Hz	IFM TYPE	ELECTRIC HEATER			NO CONVENIENCE OUTLET OR UNPOWERED CONVENIENCE OUTLET							
			CRHEATER ****00	Nom (kW)	FLA	No Power Exhaust				With Power Exhaust (powered from unit)			
						MCA	Fuse or HACR Brkr	Disconnect Size		MCA	Fuse or HACR Brkr	Disconnect Size	
								FLA	LRA			FLA	LRA
J05	460-3-60	HIGH	None	—	—	13	20	13	66	14	20	14	67
			333A	6.0	7.2	22	25	21	73	23	25	22	74
			335A	11.5	13.8	31	35	28	80	32	35	30	81
			336A	14.0	16.8	34	35	32	83	35	35	33	84
			337A	21.5	25.9	46	50	42	92	47	50	43	93
	575-3-60	STD	None	—	—	8	15	8	42	10	15	10	44
			339A	10.0	9.6	20	20	19	52	22	25	21	54
			340A	15.0	14.4	26	30	24	56	28	30	26	58
		MED	None	—	—	9	15	8	42	11	15	10	44
			339A	10.0	9.6	21	25	19	52	23	25	21	54
			340A	15.0	14.4	27	30	25	56	29	30	27	58
		HIGH	None	—	—	9	15	9	43	11	15	11	45
			339A	10.0	9.6	21	25	20	53	23	25	22	55
			340A	15.0	14.4	27	30	25	57	29	30	28	59

50GCQ*05 MCA MOCPP Electrical Data (cont)

50GCQ UNIT SIZE	NOM. V-Ph-Hz	IFM TYPE	ELECTRIC HEATER			WITH POWERED CONVENIENCE OUTLET								
			CRHEATER ****00	Nom (kW)	FLA	No Power Exhaust				With Power Exhaust (powered from unit)				
						MCA	Fuse or HACR Brkr	Disconnect Size		MCA	Fuse or HACR Brkr	Disconnect Size		
								FLA	LRA			FLA	LRA	
J05	208/230-3-60	STD	None	—	—	30	40	30	120	32	45	32	122	
			323A	3.3/4.4	9.2/10.6	41/43	50/50	40/42	129/131	43/45	50/50	42/44	131/133	
			324A	4.9/6.5	13.6/15.6	47/49	50/50	45/47	134/136	49/51	50/60	47/50	136/138	
			325A	6.5/8.7	18.1/20.9	52/56	60/60	50/54	138/141	54/58	60/60	53/56	140/143	
			328A	12.0/16.0	33.4/38.5	72/78	80/80	68/74	153/159	73/80	80/80	70/76	155/161	
			330A	14.4/19.2	40.0/46.2	80/88	80/90	76/83	160/166	82/89	90/90	78/85	162/168	
		331A	15.8/21.0	43.8/50.5	85/93	90/100	80/88	164/171	86/95	90/100	82/90	166/173		
		326A	7.9/10.5	21.9/25.3	57/61	60/70	55/59	142/145	59/63	60/70	57/61	144/147		
		MED	None	—	—	32	45	32	123	34	45	34	125	
			323A	3.3/4.4	9.2/10.6	43/45	50/50	43/44	132/134	45/47	50/50	45/46	134/136	
			324A	4.9/6.5	13.6/15.6	49/51	50/60	48/50	137/139	51/53	60/60	50/52	139/141	
			325A	6.5/8.7	18.1/20.9	55/58	60/60	53/56	141/144	56/60	60/60	55/58	143/146	
			328A	12.0/16.0	33.4/38.5	74/80	80/80	70/76	156/162	76/82	80/90	73/78	158/164	
			330A	14.4/19.2	40.0/46.2	82/90	90/90	78/85	163/169	84/92	90/100	80/87	165/171	
		331A	15.8/21.0	43.8/50.5	87/95	90/100	82/90	167/174	89/97	90/100	85/92	169/176		
		326A	7.9/10.5	21.9/25.3	59/64	60/70	57/61	145/148	61/65	70/70	59/63	147/150		
		HIGH	None	—	—	30	40	30	120	32	45	32	122	
			323A	3.3/4.4	9.2/10.6	41/43	50/50	40/42	129/131	43/45	50/50	42/44	131/133	
			324A	4.9/6.5	13.6/15.6	47/49	50/50	45/48	134/136	49/51	50/60	47/50	136/138	
			325A	6.5/8.7	18.1/20.9	53/56	60/60	50/54	138/141	54/58	60/60	53/56	140/143	
			328A	12.0/16.0	33.4/38.5	72/78	80/80	68/74	153/159	74/80	80/80	70/76	155/161	
			330A	14.4/19.2	40.0/46.2	80/88	80/90	76/83	160/166	82/90	90/90	78/85	162/168	
		331A	15.8/21.0	43.8/50.5	85/93	90/100	80/88	164/171	87/95	90/100	82/90	166/173		
		326A	7.9/10.5	21.9/25.3	57/62	60/70	55/59	142/145	59/63	60/70	57/61	144/147		
	460-3-60	STD	None	—	—	14	20	14	67	15	20	15	68	
			333A	6.0	7.2	23	25	22	74	24	25	23	75	
			335A	11.5	13.8	32	35	30	81	33	35	31	82	
			336A	14.0	16.8	35	35	33	84	36	40	34	85	
		337A	21.5	25.9	47	50	43	93	48	50	45	94		
		MED	None	—	—	15	20	14	67	16	20	15	68	
			333A	6.0	7.2	24	25	22	74	25	30	23	75	
			335A	11.5	13.8	32	35	30	81	33	35	31	82	
			336A	14.0	16.8	36	40	33	84	37	40	35	85	
		337A	21.5	25.9	47	50	44	93	48	50	45	94		
		HIGH	None	—	—	15	20	15	68	16	20	16	69	
			333A	6.0	7.2	24	25	23	75	25	30	24	76	
			335A	11.5	13.8	33	35	31	82	34	35	32	83	
			336A	14.0	16.8	36	40	34	85	37	40	36	86	
		337A	21.5	25.9	48	50	45	94	49	50	46	95		
		575-3-60	STD	None	—	—	10	15	10	44	12	15	12	46
				339A	10.0	9.6	22	25	21	54	24	25	23	56
				340A	15.0	14.4	28	30	26	58	30	30	28	60
MED	None		—	—	11	15	10	44	12	15	12	46		
	339A		10.0	9.6	23	25	21	54	24	25	23	56		
	340A		15.0	14.4	29	30	27	58	30	30	29	60		
HIGH	None		—	—	11	15	11	45	13	15	13	47		
	339A		10.0	9.6	23	25	22	55	25	25	24	57		
	340A		15.0	14.4	29	30	27	59	31	35	30	61		

50GCQ*05 MCA MOCP Electrical Data — with Factory-Installed HACR Breaker

50GCQ UNIT SIZE	NOM. V-Ph-Hz	IFM TYPE	ELECTRIC HEATER			NO CONVENIENCE OUTLET OR UNPOWERED CONVENIENCE OUTLET							
			CRHEATER ****00	Nom (kW)	FLA	No Power Exhaust				With Power Exhaust (powered from unit)			
						MCA	Fuse or HACR Brkr	Disconnect Size		MCA	Fuse or HACR Brkr	Disconnect Size	
								FLA	LRA			FLA	LRA
T05	208/230-1-60	STD	None	—	—	37	60	35	137	39	60	37	139
			323A	3.3/4.4	15.9/18.3	60/60	70/70	53/56	153/155	62/62	80/80	55/58	155/157
			325A	6.5/8.7	31.4/36.3	82/82	90/90	71/77	168/173	84/84	90/90	73/79	170/175
			327A	9.8/13.0	46.9/54.2	105/105	110/110	89/97	184/191	107/107	110/110	91/99	186/193
			329A	13.1/17.4	62.8/72.5	128/128	150/150	107/118	200/210	129/129	150/150	109/121	202/212
			330A	14.4/19.2	69.3/80.0	137/137	150/150	115/127	206/217	139/139	150/150	117/129	208/219
		331A	15.8/21.0	75.8/87.5	146/146	150/150	122/136	213/225	148/148	150/150	124/138	215/227	
		326A	7.9/10.5	37.9/43.8	92/92	100/100	79/85	175/181	94/94	100/100	81/88	177/183	
		MED	None	—	—	39	60	37	140	41	60	40	142
			323A	3.3/4.4	15.9/18.3	62/62	80/80	56/58	156/158	64/64	80/80	58/61	158/160
			325A	6.5/8.7	31.4/36.3	84/84	90/90	73/79	171/176	86/86	100/100	76/81	173/178
			327A	9.8/13.0	46.9/54.2	107/107	110/110	91/100	187/194	109/109	110/110	93/102	189/196
			329A	13.1/17.4	62.8/72.5	130/130	150/150	110/121	203/213	132/132	150/150	112/123	205/215
			330A	14.4/19.2	69.3/80.0	139/139	150/150	117/129	209/220	141/141	150/150	119/132	211/222
		331A	15.8/21.0	75.8/87.5	148/148	150/150	125/138	216/228	150/150	150/150	127/140	218/230	
		326A	7.9/10.5	37.9/43.8	94/94	100/100	81/88	178/184	96/96	100/100	83/90	180/186	
		HIGH	None	—	—	41	60	39	142	43	60	42	144
			323A	3.3/4.4	15.9/18.3	64/64	80/80	58/60	158/160	65/65	80/80	60/63	160/162
			325A	6.5/8.7	31.4/36.3	86/86	100/100	75/81	173/178	88/88	100/100	78/83	175/180
			327A	9.8/13.0	46.9/54.2	108/108	110/110	93/102	189/196	110/110	110/110	95/104	191/198
			329A	13.1/17.4	62.8/72.5	131/131	150/150	112/123	205/215	133/133	150/150	114/125	207/217
			330A	14.4/19.2	69.3/80.0	141/141	150/150	119/131	211/222	143/143	150/150	121/134	213/224
		331A	15.8/21.0	75.8/87.5	150/150	150/150	127/140	218/230	152/152	175/175	129/142	220/232	
		326A	7.9/10.5	37.9/43.8	95/95	100/100	83/90	180/186	97/97	100/100	85/92	182/188	
J05	208/230-3-60	STD	None	—	—	25	30	24	115	27	40	26	117
			323A	3.3/4.4	9.2/10.6	38/38	45/45	35/36	124/126	40/40	50/50	37/38	126/128
			324A	4.9/6.5	13.6/15.6	45/45	50/50	40/42	129/131	46/46	50/50	42/44	131/133
			325A	6.5/8.7	18.1/20.9	51/51	60/60	45/48	133/136	53/53	60/60	47/50	135/138
			328A	12.0/16.0	33.4/38.5	73/73	80/80	62/68	148/154	75/75	80/80	65/70	150/156
			330A	14.4/19.2	40.0/46.2	83/83	90/90	70/77	155/161	85/85	90/90	72/79	157/163
		331A	15.8/21.0	43.8/50.5	88/88	90/90	74/82	159/166	90/90	90/90	77/84	161/168	
		326A	7.9/10.5	21.9/25.3	57/57	60/60	49/53	137/140	59/59	60/60	51/55	139/142	
		MED	None	—	—	27	40	26	118	29	40	29	120
			323A	3.3/4.4	9.2/10.6	40/40	50/50	37/39	127/129	42/42	50/50	39/41	129/131
			324A	4.9/6.5	13.6/15.6	47/47	50/50	42/44	132/134	49/49	50/50	44/47	134/136
			325A	6.5/8.7	18.1/20.9	53/53	60/60	47/50	136/139	55/55	60/60	49/53	138/141
			328A	12.0/16.0	33.4/38.5	75/75	80/80	65/71	151/157	77/77	80/80	67/73	153/159
			330A	14.4/19.2	40.0/46.2	85/85	90/90	72/80	158/164	87/87	90/90	75/82	160/166
		331A	15.8/21.0	43.8/50.5	90/90	90/90	77/85	162/169	92/92	100/100	79/87	164/171	
		326A	7.9/10.5	21.9/25.3	59/59	60/60	52/56	140/143	61/61	70/70	54/58	142/145	
		HIGH	None	—	—	25	30	24	115	27	40	26	117
			323A	3.3/4.4	9.2/10.6	38/38	45/45	35/36	124/126	40/40	50/50	37/39	126/128
			324A	4.9/6.5	13.6/15.6	45/45	50/50	40/42	129/131	47/47	50/50	42/44	131/133
			325A	6.5/8.7	18.1/20.9	51/51	60/60	45/48	133/136	53/53	60/60	47/50	135/138
			328A	12.0/16.0	33.4/38.5	73/73	80/80	63/68	148/154	75/75	80/80	65/71	150/156
			330A	14.4/19.2	40.0/46.2	83/83	90/90	70/77	155/161	85/85	90/90	72/79	157/163
		331A	15.8/21.0	43.8/50.5	88/88	90/90	75/82	159/166	90/90	90/90	77/84	161/168	
		326A	7.9/10.5	21.9/25.3	57/57	60/60	49/53	137/140	59/59	60/60	52/55	139/142	
460-3-60	STD	None	—	—	12	15	11	65	13	20	12	66	
		333A	6.0	7.2	21	25	19	72	22	25	21	73	
		335A	11.5	13.8	29	30	27	79	30	30	28	80	
		336A	14.0	16.8	33	35	30	82	34	35	32	83	
		337A	21.5	25.9	44	45	41	91	45	45	42	92	
		None	—	—	12	15	11	65	13	20	13	66	
	MED	333A	6.0	7.2	21	25	19	72	22	25	21	73	
		335A	11.5	13.8	29	30	27	79	30	35	29	80	
		336A	14.0	16.8	33	35	30	82	34				
		337A	21.5	25.9	44	45	41	91	45	35	32	83	

Electrical data (cont)



50GCQ*05 MCA MOCP Electrical Data — with Factory-Installed HACR Breaker (cont)

50GCQ UNIT SIZE	NOM. V-Ph-Hz	IFM TYPE	ELECTRIC HEATER			NO CONVENIENCE OUTLET OR UNPOWERED CONVENIENCE OUTLET							
			CRHEATER ****00	Nom (kW)	FLA	No Power Exhaust				With Power Exhaust (powered from unit)			
						MCA	Fuse or HACR Brkr	Disconnect Size		MCA	Fuse or HACR Brkr	Disconnect Size	
								FLA	LRA			FLA	LRA
J05 (cont)	460-3-60	HIGH	None	—	—	13	20	13	66	14	20	14	67
			333A	6.0	7.2	22	25	21	73	23	25	22	74
			335A	11.5	13.8	31	35	28	80	32	35	30	81
			336A	14.0	16.8	34	35	32	83	35	35	33	84
			337A	21.5	25.9	46	50	42	92	47	50	43	93
	575-3-60	STD	None	—	—	8	15	8	42	10	15	10	44
			339A	10.0	9.6	20	20	19	52	22	25	21	54
			340A	15.0	14.4	26	30	24	56	28	30	26	58
		MED	None	—	—	9	15	8	42	11	15	10	44
			339A	10.0	9.6	21	25	19	52	23	25	21	54
			340A	15.0	14.4	27	30	25	56	29	30	27	58
		HIGH	None	—	—	9	15	9	43	11	15	11	45
			339A	10.0	9.6	21	25	20	53	23	25	22	55
			340A	15.0	14.4	27	30	25	57	29	30	28	59

50GCQ*05 MCA MOCOP Electrical Data — with Factory-Installed HACR Breaker (cont)

50GCQ UNIT SIZE	NOM. V-Ph-Hz	IFM TYPE	ELECTRIC HEATER			WITH POWERED CONVENIENCE OUTLET							
			CRHEATER ****00	Nom (kW)	FLA	No Power Exhaust				With Power Exhaust (powered from unit)			
						MCA	Fuse or HACR Brkr	Disconnect Size		MCA	Fuse or HACR Brkr	Disconnect Size	
								FLA	LRA			FLA	LRA
J05	208/230-3-60	STD	None	—	—	30	40	30	120	32	45	32	122
			323A	3.3/4.4	9.2/10.6	43/43	50/50	40/42	129/131	45/45	50/50	42/44	131/133
			324A	4.9/6.5	13.6/15.6	49/49	50/50	45/47	134/136	51/51	60/60	47/50	136/138
			325A	6.5/8.7	18.1/20.9	56/56	60/60	50/54	138/141	58/58	60/60	53/56	140/143
			328A	12.0/16.0	33.4/38.5	78/78	80/80	68/74	153/159	80/80	80/80	70/76	155/161
			330A	14.4/19.2	40.0/46.2	88/88	90/90	76/83	160/166	89/89	90/90	78/85	162/168
		331A	15.8/21.0	43.8/50.5	93/93	100/100	80/88	164/171	95/95	100/100	82/90	166/173	
		326A	7.9/10.5	21.9/25.3	61/61	70/70	55/59	142/145	63/63	70/70	57/61	144/147	
		None	—	—	32	45	32	123	34	45	34	125	
		323A	3.3/4.4	9.2/10.6	45/45	50/50	43/44	132/134	47/47	50/50	45/46	134/136	
		324A	4.9/6.5	13.6/15.6	51/51	60/60	48/50	137/139	53/53	60/60	50/52	139/141	
		325A	6.5/8.7	18.1/20.9	58/58	60/60	53/56	141/144	60/60	60/60	55/58	143/146	
		328A	12.0/16.0	33.4/38.5	80/80	80/80	70/76	156/162	82/82	90/90	73/78	158/164	
		330A	14.4/19.2	40.0/46.2	90/90	90/90	78/85	163/169	92/92	100/100	80/87	165/171	
		331A	15.8/21.0	43.8/50.5	95/95	100/100	82/90	167/174	97/97	100/100	85/92	169/176	
		326A	7.9/10.5	21.9/25.3	64/64	70/70	57/61	145/148	65/65	70/70	59/63	147/150	
		None	—	—	30	40	30	120	32	45	32	122	
		323A	3.3/4.4	9.2/10.6	43/43	50/50	40/42	129/131	45/45	50/50	42/44	131/133	
		324A	4.9/6.5	13.6/15.6	49/49	50/50	45/48	134/136	51/51	60/60	47/50	136/138	
		325A	6.5/8.7	18.1/20.9	56/56	60/60	50/54	138/141	58/58	60/60	53/56	140/143	
		328A	12.0/16.0	33.4/38.5	78/78	80/80	68/74	153/159	80/80	80/80	70/76	155/161	
		330A	14.4/19.2	40.0/46.2	88/88	90/90	76/83	160/166	90/90	90/90	78/85	162/168	
		331A	15.8/21.0	43.8/50.5	93/93	100/100	80/88	164/171	95/95	100/100	82/90	166/173	
		326A	7.9/10.5	21.9/25.3	62/62	70/70	55/59	142/145	63/63	70/70	57/61	144/147	
	None	—	—	14	20	14	67	15	20	15	68		
	333A	6.0	7.2	23	25	22	74	24	25	23	75		
	335A	11.5	13.8	32	35	30	81	33	35	31	82		
	336A	14.0	16.8	35	35	33	84	36	40	34	85		
	337A	21.5	25.9	47	50	43	93	48	50	45	94		
	None	—	—	15	20	14	67	16	20	15	68		
	333A	6.0	7.2	24	25	22	74	25	30	23	75		
	335A	11.5	13.8	32	35	30	81	33	35	31	82		
	336A	14.0	16.8	36	40	33	84	37	40	35	85		
	337A	21.5	25.9	47	50	44	93	48	50	45	94		
	None	—	—	15	20	15	68	16	20	16	69		
	333A	6.0	7.2	24	25	23	75	25	30	24	76		
	335A	11.5	13.8	33	35	31	82	34	35	32	83		
	336A	14.0	16.8	36	40	34	85	37	40	36	86		
	337A	21.5	25.9	48	50	45	94	49	50	46	95		
	None	—	—	10	15	10	44	12	15	12	46		
	339A	10.0	9.6	22	25	21	54	24	25	23	56		
	340A	15.0	14.4	28	30	26	58	30	30	28	60		
	None	—	—	11	15	10	44	12	15	12	46		
	339A	10.0	9.6	23	25	21	54	24	25	23	56		
	340A	15.0	14.4	29	30	27	58	30	30	29	60		
	None	—	—	11	15	11	45	13	15	13	47		
	339A	10.0	9.6	23	25	22	55	25	25	24	57		
	340A	15.0	14.4	29	30	27	59	31	35	30	61		

50GCQ*06 MCA MOCPP Electrical Data

50GCQ UNIT SIZE	NOM. V-Ph-Hz	IFM TYPE	ELECTRIC HEATER			NO CONVENIENCE OUTLET OR UNPOWERED CONVENIENCE OUTLET							
			CRHEATER ****00	Nom (kW)	FLA	No Power Exhaust				With Power Exhaust (powered from unit)			
						MCA	Fuse or HACR Brkr	Disconnect Size		MCA	Fuse or HACR Brkr	Disconnect Size	
								FLA	LRA			FLA	LRA
T06	208/230-1-60	STD	None	—	—	47	60	44	171	48	60	47	173
			324A	4.9/6.5	23.5/27.1	76/80	80/100	71/76	195/198	78/82	80/100	74/78	197/200
			325A	6.5/8.7	31.4/36.3	86/92	100/100	81/86	202/207	88/94	100/100	83/88	204/209
			327A	9.8/13.0	46.9/54.2	105/114	110/125	98/107	218/225	107/116	125/125	101/109	220/227
			329A	13.1/17.4	62.8/72.5	125/137	125/150	117/128	234/244	127/139	150/150	119/130	236/246
		331A	15.8/21.0	75.8/87.5	141/156	150/175	132/145	247/259	143/158	150/175	134/147	249/261	
		MED	None	—	—	48	60	46	173	50	60	48	175
			324A	4.9/6.5	23.5/27.1	77/82	80/100	73/77	197/200	79/84	100/100	75/79	199/202
			325A	6.5/8.7	31.4/36.3	87/93	100/100	82/88	204/209	89/95	100/100	84/90	206/211
			327A	9.8/13.0	46.9/54.2	107/116	110/125	100/108	220/227	109/118	125/125	102/111	222/229
329A	13.1/17.4		62.8/72.5	126/139	150/150	118/129	236/246	128/141	150/150	120/132	238/248		
T06	208/230-3-60	STD	None	—	—	31	45	30	123	33	45	32	125
			324A	4.9/6.5	13.6/15.6	48/50	60/60	46/48	137/139	50/52	60/60	48/50	139/141
			326A	7.9/10.5	21.9/25.3	58/62	60/70	55/59	145/148	60/64	60/70	57/61	147/150
			328A	12.0/16.0	33.4/38.5	73/79	80/80	68/74	156/162	74/81	80/90	70/76	158/164
			331A	15.8/21.0	43.8/50.5	86/94	90/100	80/88	167/174	87/96	90/100	82/90	169/176
			332A	18.4/24.5	51.1/58.9	95/104	100/110	89/98	174/182	97/106	100/110	91/100	176/184
		MED	None	—	—	32	45	32	125	34	50	34	127
			324A	4.9/6.5	13.6/15.6	49/52	60/60	47/49	139/141	51/54	60/60	49/52	141/143
			326A	7.9/10.5	21.9/25.3	60/64	60/70	57/61	147/150	62/66	70/70	59/63	149/152
			328A	12.0/16.0	33.4/38.5	74/80	80/80	70/76	158/164	76/82	80/90	72/78	160/166
			331A	15.8/21.0	43.8/50.5	87/95	90/100	82/90	169/176	89/97	90/100	84/92	171/178
			332A	18.4/24.5	51.1/58.9	96/106	100/110	90/99	176/184	98/108	100/110	92/101	178/186
		HIGH	None	—	—	30	45	29	122	32	45	31	124
			324A	4.9/6.5	13.6/15.6	47/50	60/60	45/47	136/138	49/51	60/60	47/49	138/140
			326A	7.9/10.5	21.9/25.3	57/62	60/70	54/58	144/147	59/64	60/70	56/60	146/149
			328A	12.0/16.0	33.4/38.5	72/78	80/80	67/73	155/161	74/80	80/80	70/75	157/163
			331A	15.8/21.0	43.8/50.5	85/93	90/100	79/87	166/173	87/95	90/100	82/89	168/175
			332A	18.4/24.5	51.1/58.9	94/104	100/110	88/97	173/181	96/106	100/110	90/99	175/183
J06	460-3-60	STD	None	—	—	13	20	12	58	14	20	13	59
			333A	6.0	7.2	22	25	20	65	23	25	21	66
			335A	11.5	13.8	30	30	28	72	31	35	29	73
			336A	14.0	16.8	34	35	31	75	35	35	32	76
			337A	21.5	25.9	45	45	42	84	46	50	43	85
			338A	24.0	28.9	49	50	45	87	50	50	46	88
		MED	None	—	—	13	20	12	59	14	20	13	60
			333A	6.0	7.2	22	25	21	66	23	25	22	67
			335A	11.5	13.8	30	30	28	73	31	35	29	74
			336A	14.0	16.8	34	35	32	76	35	35	33	77
			337A	21.5	25.9	46	50	42	85	47	50	43	86
			338A	24.0	28.9	49	50	46	88	50	50	47	89
		HIGH	None	—	—	14	20	13	60	15	20	15	61
			333A	6.0	7.2	23	25	22	67	24	25	23	68
			335A	11.5	13.8	31	35	29	74	32	35	30	75
			336A	14.0	16.8	35	35	33	77	36	40	34	78
			337A	21.5	25.9	47	50	43	86	48	50	44	87
			338A	24.0	28.9	50	50	47	89	51	60	48	90
J06	575-3-60	STD	None	—	—	11	15	10	51	13	15	12	53
			340A	15.0	14.4	29	30	27	65	31	35	29	67
			341A	21.0	20.2	36	40	33	71	38	40	36	73
		MED	None	—	—	11	15	10	52	13	15	13	54
			340A	15.0	14.4	29	30	27	66	31	35	29	68
			341A	21.0	20.2	36	40	34	72	38	40	36	74
		HIGH	None	—	—	12	15	11	53	14	20	13	55
			340A	15.0	14.4	30	30	28	67	32	35	30	69
			341A	21.0	20.2	37	40	35	73	39	40	37	75

50GCQ*06 MCA MOCPP Electrical Data (cont)

50GCQ UNIT SIZE	NOM. V-Ph-Hz	IFM TYPE	ELECTRIC HEATER			WITH POWERED CONVENIENCE OUTLET							
			CRHEATER ****00	Nom (kW)	FLA	No Power Exhaust				With Power Exhaust (powered from unit)			
						MCA	Fuse or HACR Brkr	Disconnect Size		MCA	Fuse or HACR Brkr	Disconnect Size	
								FLA	LRA			FLA	LRA
J06	208/230-3-60	STD	None	—	—	36	50	35	128	38	50	38	130
			324A	4.9/6.5	13.6/15.6	53/55	60/60	51/53	142/144	55/57	60/60	53/56	144/146
			326A	7.9/10.5	21.9/25.3	63/67	70/70	61/65	150/153	65/69	70/70	63/67	152/155
			328A	12.0/16.0	33.4/38.5	77/84	80/90	74/80	161/167	79/86	80/90	76/82	163/169
			331A	15.8/21.0	43.8/50.5	90/99	90/100	86/93	172/179	92/101	100/110	88/96	174/181
		332A	18.4/24.5	51.1/58.9	100/109	100/110	94/103	179/187	101/111	110/125	96/105	181/189	
		MED	None	—	—	37	50	37	130	39	50	39	132
			324A	4.9/6.5	13.6/15.6	54/57	60/60	53/55	144/146	56/58	60/60	55/57	146/148
			326A	7.9/10.5	21.9/25.3	64/69	70/70	62/66	152/155	66/71	70/80	64/68	154/157
			328A	12.0/16.0	33.4/38.5	79/85	80/90	75/81	163/169	81/87	90/90	78/83	165/171
			331A	15.8/21.0	43.8/50.5	92/100	100/100	87/95	174/181	94/102	100/110	90/97	176/183
		332A	18.4/24.5	51.1/58.9	101/111	110/125	96/105	181/189	103/113	110/125	98/107	183/191	
		HIGH	None	—	—	35	50	35	127	37	50	37	129
			324A	4.9/6.5	13.6/15.6	52/54	60/60	50/52	141/143	54/56	60/60	52/55	143/145
			326A	7.9/10.5	21.9/25.3	62/66	70/70	60/64	149/152	64/68	70/70	62/66	151/154
	328A		12.0/16.0	33.4/38.5	77/83	80/90	73/79	160/166	78/85	80/90	75/81	162/168	
	331A		15.8/21.0	43.8/50.5	90/98	90/100	85/93	171/178	91/100	100/100	87/95	173/180	
	332A	18.4/24.5	51.1/58.9	99/108	100/110	93/102	178/186	101/110	110/110	95/104	180/188		
	460-3-60	STD	None	—	—	15	20	14	60	16	20	16	61
			333A	6.0	7.2	24	25	23	67	25	30	24	68
			335A	11.5	13.8	32	35	30	74	33	35	31	75
			336A	14.0	16.8	36	40	34	77	37	40	35	78
			337A	21.5	25.9	47	50	44	86	48	50	45	87
		338A	24.0	28.9	51	60	48	89	52	60	49	90	
		MED	None	—	—	15	20	15	61	16	20	16	62
			333A	6.0	7.2	24	30	23	68	25	30	24	69
			335A	11.5	13.8	33	35	31	75	34	35	32	76
336A			14.0	16.8	36	40	34	78	37	40	35	79	
337A			21.5	25.9	48	50	45	87	49	50	46	88	
338A		24.0	28.9	51	60	48	90	52	60	49	91		
HIGH	None	—	—	16	20	16	62	17	20	17	63		
	333A	6.0	7.2	25	30	24	69	26	30	25	70		
	335A	11.5	13.8	34	35	32	76	35	35	33	77		
	336A	14.0	16.8	37	40	35	79	38	40	36	80		
	337A	21.5	25.9	49	50	46	88	50	50	47	89		
338A	24.0	28.9	52	60	49	91	53	60	50	92			
575-3-60	STD	None	—	—	13	15	12	53	15	20	14	55	
		340A	15.0	14.4	31	35	29	67	33	35	31	69	
		341A	21.0	20.2	38	40	35	73	40	40	37	75	
	MED	None	—	—	13	15	12	54	15	20	15	56	
		340A	15.0	14.4	31	35	29	68	33	35	31	70	
		341A	21.0	20.2	38	40	36	74	40	40	38	76	
	HIGH	None	—	—	14	15	13	55	16	20	15	57	
		340A	15.0	14.4	32	35	30	69	34	35	32	71	
		341A	21.0	20.2	39	40	36	75	41	45	39	77	

50GCQ*06 MCA MOCP Electrical Data with Factory-Installed HACR Breaker

50GCQ UNIT SIZE	NOM. V-Ph-Hz	FM TYPE	ELECTRIC HEATER			NO CONVENIENCE OUTLET OR UNPOWERED CONVENIENCE OUTLET							
			CRHEATER ****00	Nom (kW)	FLA	No Power Exhaust				With Power Exhaust (powered from unit)			
						MCA	Fuse or HACR Brkr	Disconnect Size		MCA	Fuse or HACR Brkr	Disconnect Size	
								FLA	LRA			FLA	LRA
T06	208/230-1-60	STD	None	—	—	47	60	44	171	48	60	47	173
			324A	4.9/6.5	23.5/27.1	80/80	100/100	71/76	195/198	82/82	100/100	74/78	197/200
			325A	6.5/8.7	31.4/36.3	92/92	100/100	81/86	202/207	94/94	100/100	83/88	204/209
			327A	9.8/13.0	46.9/54.2	114/114	125/125	98/107	218/225	116/116	125/125	101/109	220/227
			329A	13.1/17.4	62.8/72.5	137/137	150/150	117/128	234/244	139/139	150/150	119/130	236/246
		331A	15.8/21.0	75.8/87.5	156/156	175/175	132/145	247/259	158/158	175/175	134/147	249/261	
		MED	None	—	—	48	60	46	173	50	60	48	175
			324A	4.9/6.5	23.5/27.1	82/82	100/100	73/77	197/200	84/84	100/100	75/79	199/202
			325A	6.5/8.7	31.4/36.3	93/93	100/100	82/88	204/209	95/95	100/100	84/90	206/211
			327A	9.8/13.0	46.9/54.2	116/116	125/125	100/108	220/227	118/118	125/125	102/111	222/229
329A	13.1/17.4		62.8/72.5	139/139	150/150	118/129	236/246	141/141	150/150	120/132	238/248		
T06	208/230-3-60	STD	None	—	—	31	45	30	123	33	45	32	125
			324A	4.9/6.5	13.6/15.6	50/50	60/60	46/48	137/139	52/52	60/60	48/50	139/141
			326A	7.9/10.5	21.9/25.3	62/62	70/70	55/59	145/148	64/64	70/70	57/61	147/150
			328A	12.0/16.0	33.4/38.5	79/79	80/80	68/74	156/162	81/81	90/90	70/76	158/164
			331A	15.8/21.0	43.8/50.5	94/94	100/100	80/88	167/174	96/96	100/100	82/90	169/176
			332A	18.4/24.5	51.1/58.9	104/104	110/110	89/98	174/182	106/106	110/110	91/100	176/184
		MED	None	—	—	32	45	32	125	34	50	34	127
			324A	4.9/6.5	13.6/15.6	52/52	60/60	47/49	139/141	54/54	60/60	49/52	141/143
			326A	7.9/10.5	21.9/25.3	64/64	70/70	57/61	147/150	66/66	70/70	59/63	149/152
			328A	12.0/16.0	33.4/38.5	80/80	80/80	70/76	158/164	82/82	90/90	72/78	160/166
			331A	15.8/21.0	43.8/50.5	95/95	100/100	82/90	169/176	97/97	100/100	84/92	171/178
			332A	18.4/24.5	51.1/58.9	106/106	110/110	90/99	176/184	108/108	110/110	92/101	178/186
		HIGH	None	—	—	30	45	29	122	32	45	31	124
			324A	4.9/6.5	13.6/15.6	50/50	60/60	45/47	136/138	51/51	60/60	47/49	138/140
			326A	7.9/10.5	21.9/25.3	62/62	70/70	54/58	144/147	64/64	70/70	56/60	146/149
			328A	12.0/16.0	33.4/38.5	78/78	80/80	67/73	155/161	80/80	80/80	70/75	157/163
			331A	15.8/21.0	43.8/50.5	93/93	100/100	79/87	166/173	95/95	100/100	82/89	168/175
			332A	18.4/24.5	51.1/58.9	104/104	110/110	88/97	173/181	106/106	110/110	90/99	175/183
J06	460-3-60	STD	None	—	—	13	20	12	58	14	20	13	59
			333A	6.0	7.2	22	25	20	65	23	25	21	66
			335A	11.5	13.8	30	30	28	72	31	35	29	73
			336A	14.0	16.8	34	35	31	75	35	35	32	76
			337A	21.5	25.9	45	45	42	84	46	50	43	85
			338A	24.0	28.9	49	50	45	87	50	50	46	88
		MED	None	—	—	13	20	12	59	14	20	13	60
			333A	6.0	7.2	22	25	21	66	23	25	22	67
			335A	11.5	13.8	30	30	28	73	31	35	29	74
			336A	14.0	16.8	34	35	32	76	35	35	33	77
			337A	21.5	25.9	46	50	42	85	47	50	43	86
			338A	24.0	28.9	49	50	46	88	50	50	47	89
		HIGH	None	—	—	14	20	13	60	15	20	15	61
			333A	6.0	7.2	23	25	22	67	24	25	23	68
			335A	11.5	13.8	31	35	29	74	32	35	30	75
			336A	14.0	16.8	35	35	33	77	36	40	34	78
			337A	21.5	25.9	47	50	43	86	48	50	44	87
			338A	24.0	28.9	50	50	47	89	51	60	48	90
J06	575-3-60	STD	None	—	—	11	15	10	51	13	15	12	53
			340A	15.0	14.4	29	30	27	65	31	35	29	67
			341A	21.0	20.2	36	40	33	71	38	40	36	73
		MED	None	—	—	11	15	10	52	13	15	13	54
			340A	15.0	14.4	29	30	27	66	31	35	29	68
			341A	21.0	20.2	36	40	34	72	38	40	36	74
		HIGH	None	—	—	12	15	11	53	14	20	13	55
			340A	15.0	14.4	30	30	28	67	32	35	30	69
			341A	21.0	20.2	37	40	35	73	39	40	37	75

50GCQ*06 MCA MOCP Electrical Data with Factory-Installed HACR Breaker

50GCQ UNIT SIZE	NOM. V-Ph-Hz	FM TYPE	ELECTRIC HEATER			WITH POWERED CONVENIENCE OUTLET							
			CRHEATER ****00	Nom (kW)	FLA	No Power Exhaust				With Power Exhaust (powered from unit)			
						MCA	Fuse or HACR Brkr	Disconnect Size		MCA	Fuse or HACR Brkr	Disconnect Size	
								FLA	LRA			FLA	LRA
J06	208/230-3-60	STD	None	—	—	36	50	35	128	38	50	38	130
			324A	4.9/6.5	13.6/15.6	55/55	60/60	51/53	142/144	57/57	60/60	53/56	144/146
			326A	7.9/10.5	21.9/25.3	67/67	70/70	61/65	150/153	69/69	70/70	63/67	152/155
			328A	12.0/16.0	33.4/38.5	84/84	90/90	74/80	161/167	86/86	90/90	76/82	163/169
			331A	15.8/21.0	43.8/50.5	99/99	100/100	86/93	172/179	101/101	110/110	88/96	174/181
			332A	18.4/24.5	51.1/58.9	109/109	110/110	94/103	179/187	111/111	125/125	96/105	181/189
		MED	None	—	—	37	50	37	130	39	50	39	132
			324A	4.9/6.5	13.6/15.6	57/57	60/60	53/55	144/146	58/58	60/60	55/57	146/148
			326A	7.9/10.5	21.9/25.3	69/69	70/70	62/66	152/155	71/71	80/80	64/68	154/157
			328A	12.0/16.0	33.4/38.5	85/85	90/90	75/81	163/169	87/87	90/90	78/83	165/171
			331A	15.8/21.0	43.8/50.5	100/100	100/100	87/95	174/181	102/102	110/110	90/97	176/183
			332A	18.4/24.5	51.1/58.9	111/111	125/125	96/105	181/189	113/113	125/125	98/107	183/191
		HIGH	None	—	—	35	50	35	127	37	50	37	129
			324A	4.9/6.5	13.6/15.6	54/54	60/60	50/52	141/143	56/56	60/60	52/55	143/145
			326A	7.9/10.5	21.9/25.3	66/66	70/70	60/64	149/152	68/68	70/70	62/66	151/154
			328A	12.0/16.0	33.4/38.5	83/83	90/90	73/79	160/166	85/85	90/90	75/81	162/168
			331A	15.8/21.0	43.8/50.5	98/98	100/100	85/93	171/178	100/100	100/100	87/95	173/180
			332A	18.4/24.5	51.1/58.9	108/108	110/110	93/102	178/186	110/110	110/110	95/104	180/188
	460-3-60	STD	None	—	—	15	20	14	60	16	20	16	61
			333A	6.0	7.2	24	25	23	67	25	30	24	68
			335A	11.5	13.8	32	35	30	74	33	35	31	75
			336A	14.0	16.8	36	40	34	77	37	40	35	78
			337A	21.5	25.9	47	50	44	86	48	50	45	87
			338A	24.0	28.9	51	60	48	89	52	60	49	90
		MED	None	—	—	15	20	15	61	16	20	16	62
			333A	6.0	7.2	24	30	23	68	25	30	24	69
			335A	11.5	13.8	33	35	31	75	34	35	32	76
			336A	14.0	16.8	36	40	34	78	37	40	35	79
			337A	21.5	25.9	48	50	45	87	49	50	46	88
			338A	24.0	28.9	51	60	48	90	52	60	49	91
		HIGH	None	—	—	16	20	16	62	17	20	17	63
			333A	6.0	7.2	25	30	24	69	26	30	25	70
			335A	11.5	13.8	34	35	32	76	35	35	33	77
			336A	14.0	16.8	37	40	35	79	38	40	36	80
			337A	21.5	25.9	49	50	46	88	50	50	47	89
			338A	24.0	28.9	52	60	49	91	53	60	50	92
575-3-60	STD	None	—	—	13	15	12	53	15	20	14	55	
		340A	15.0	14.4	31	35	29	67	33	35	31	69	
		341A	21.0	20.2	38	40	35	73	40	40	37	75	
	MED	None	—	—	13	15	12	54	15	20	15	56	
		340A	15.0	14.4	31	35	29	68	33	35	31	70	
		341A	21.0	20.2	38	40	36	74	40	40	38	76	
	HIGH	None	—	—	14	15	13	55	16	20	15	57	
		340A	15.0	14.4	32	35	30	69	34	35	32	71	
		341A	21.0	20.2	39	40	36	75	41	45	39	77	

50GCQ*04 Electric Heat Data — without Non-Fused Disconnect

50GCQ UNIT SIZE	NOM. V-Ph-Hz	IFM TYPE	ELECTRIC HEATER PART NUMBER	NOM (kW)	APPLICATION (kW)	APPLICATION OUTPUT (MBH)	SINGLE POINT OR JUNCTION KIT PART NUMBER CRSINGLEXXXXA00			
							No C.O. or Unpowered C.O.		With Pwr'd C.O.	
							No P.E.	With P.E. (pwr'd fr/unit)	No P.E.	With P.E. (pwr'd fr/unit)
T04	208/230-1-60	STD	CRHEATER323A00	4.4	3.3/4.0	11.3/13.8	—	—	—	—
			CRHEATER324A00	6.5	4.9/6.0	16.7/20.4	037	037	—	—
			CRHEATER325A00	8.7	6.5/8.0	22.3/27.3	040	040	—	—
			CRHEATER326A00	10.5	7.9/9.6	26.9/32.9	040	040	—	—
			CRHEATER327A00	13.0	9.8/11.9	33.3/40.7	041	041	—	—
		MED	CRHEATER323A00	4.4	3.3/4.0	11.3/13.8	—	037	—	—
			CRHEATER324A00	6.5	4.9/6.0	16.7/20.4	037	040	—	—
			CRHEATER325A00	8.7	6.5/8.0	22.3/27.3	040	040	—	—
			CRHEATER326A00	10.5	7.9/9.6	26.9/32.9	040	040	—	—
			CRHEATER327A00	13.0	9.8/11.9	33.3/40.7	041	041	—	—
		HIGH	CRHEATER323A00	4.4	3.3/4.0	11.3/13.8	037	037	—	—
			CRHEATER324A00	6.5	4.9/6.0	16.7/20.4	040	040	—	—
			CRHEATER325A00	8.7	6.5/8.0	22.3/27.3	040	040	—	—
			CRHEATER326A00	10.5	7.9/9.6	26.9/32.9	040	040	—	—
			CRHEATER327A00	13.0	9.8/11.9	33.3/40.7	041	041	—	—
		J04	208/230-3-60	STD	CRHEATER323A00	4.4	3.3/4.0	11.3/13.8	—	—
CRHEATER324A00	6.5				4.9/6.0	16.7/20.4	—	—	—	—
CRHEATER325A00	8.7				6.5/8.0	22.3/27.3	—	—	—	—
CRHEATER326A00	10.5				7.9/9.6	26.9/32.9	—	037	037	037
CRHEATER328A00	16.0				12.0/14.7	41.0/50.1	038	038	038	038
MED	CRHEATER323A00			4.4	3.3/4.0	11.3/13.8	—	—	—	—
	CRHEATER324A00			6.5	4.9/6.0	16.7/20.4	—	—	—	—
	CRHEATER325A00			8.7	6.5/8.0	22.3/27.3	—	—	—	037
	CRHEATER326A00			10.5	7.9/9.6	26.9/32.9	037	037	037	037
	CRHEATER328A00			16.0	12.0/14.7	41.0/50.1	038	038	038	038
HIGH	CRHEATER323A00			4.4	3.3/4.0	11.3/13.8	—	—	—	—
	CRHEATER324A00			6.5	4.9/6.0	16.7/20.4	—	—	—	—
	CRHEATER325A00			8.7	6.5/8.0	22.3/27.3	—	—	037	037
	CRHEATER326A00			10.5	7.9/9.6	26.9/32.9	037	037	037	037
	CRHEATER328A00			16.0	12.0/14.7	41.0/50.1	038	038	038	038
460-3-60	STD		CRHEATER333A00	6.0	5.5	18.8	—	—	—	—
			CRHEATER334A00	8.8	8.1	27.6	—	—	—	—
			CRHEATER335A00	11.5	10.6	36.0	—	—	—	—
			CRHEATER336A00	14.0	12.9	43.9	—	—	—	—
	MED		CRHEATER333A00	6.0	5.5	18.8	—	—	—	—
		CRHEATER334A00	8.8	8.1	27.6	—	—	—	—	
		CRHEATER335A00	11.5	10.6	36.0	—	—	—	—	
		CRHEATER336A00	14.0	12.9	43.9	—	—	—	—	
	575-3-60	STD	CRHEATER333A00	6.0	5.5	18.8	—	—	—	—
CRHEATER334A00	8.8		8.1	27.6	—	—	—	—		
MED	CRHEATER335A00	11.5	10.6	36.0	—	—	—	—		
	CRHEATER336A00	14.0	12.9	43.9	—	—	—	—		
HIGH	CRHEATER339A00	10.0	9.2	31.3	—	—	—	—		
	CRHEATER340A00	15.0	13.8	47.0	—	—	—	—		
575-3-60	MED	CRHEATER339A00	10.0	9.2	31.3	—	—	—	—	
		CRHEATER340A00	15.0	13.8	47.0	—	—	—	—	
HIGH	CRHEATER339A00	10.0	9.2	31.3	—	—	—	—		
	CRHEATER340A00	15.0	13.8	47.0	—	—	—	—		

50GCQ*04 Electric Heat Data — with Non-Fused Disconnect

50GCQ UNIT SIZE	NOM. V-Ph-Hz	IFM TYPE	ELECTRIC HEATER PART NUMBER	NOM (kW)	APPLICATION (kW)	APPLICATION OUTPUT (MBH)	SINGLE POINT OR JUNCTION KIT PART NUMBER CRSINGLEXXXA00			
							No C.O. or Unpowered C.O.		With Pwr'd C.O.	
							No P.E.	With P.E. (pwr'd fr/unit)	No P.E.	With P.E. (pwr'd fr/unit)
T04	208/230-1-60	STD	CRHEATER323A00	4.4	3.3/4.0	11.3/13.8	037	037	—	—
			CRHEATER324A00	6.5	4.9/6.0	16.7/20.4	037	037	—	—
			CRHEATER325A00	8.7	6.5/8.0	22.3/27.3	040	040	—	—
			CRHEATER326A00	10.5	7.9/9.6	26.9/32.9	040	040	—	—
			CRHEATER327A00	13.0	9.8/11.9	33.3/40.7	041	041	—	—
		MED	CRHEATER323A00	4.4	3.3/4.0	11.3/13.8	037	037	—	—
			CRHEATER324A00	6.5	4.9/6.0	16.7/20.4	037	040	—	—
			CRHEATER325A00	8.7	6.5/8.0	22.3/27.3	040	040	—	—
			CRHEATER326A00	10.5	7.9/9.6	26.9/32.9	040	040	—	—
			CRHEATER327A00	13.0	9.8/11.9	33.3/40.7	041	041	—	—
		HIGH	CRHEATER323A00	4.4	3.3/4.0	11.3/13.8	037	037	—	—
			CRHEATER324A00	6.5	4.9/6.0	16.7/20.4	040	040	—	—
			CRHEATER325A00	8.7	6.5/8.0	22.3/27.3	040	040	—	—
			CRHEATER326A00	10.5	7.9/9.6	26.9/32.9	040	040	—	—
			CRHEATER327A00	13.0	9.8/11.9	33.3/40.7	041	041	—	—
			CRHEATER327A00	13.0	9.8/11.9	33.3/40.7	041	041	—	—
J04	208/230-3-60	STD	CRHEATER323A00	4.4	3.3/4.0	11.3/13.8	037	037	037	037
			CRHEATER324A00	6.5	4.9/6.0	16.7/20.4	037	037	037	037
			CRHEATER325A00	8.7	6.5/8.0	22.3/27.3	037	037	037	037
			CRHEATER326A00	10.5	7.9/9.6	26.9/32.9	037	037	037	037
			CRHEATER328A00	16.0	12.0/14.7	41.0/50.1	038	038	038	038
		MED	CRHEATER323A00	4.4	3.3/4.0	11.3/13.8	037	037	037	037
			CRHEATER324A00	6.5	4.9/6.0	16.7/20.4	037	037	037	037
			CRHEATER325A00	8.7	6.5/8.0	22.3/27.3	037	037	037	037
			CRHEATER326A00	10.5	7.9/9.6	26.9/32.9	037	037	037	037
			CRHEATER328A00	16.0	12.0/14.7	41.0/50.1	038	038	038	038
		HIGH	CRHEATER323A00	4.4	3.3/4.0	11.3/13.8	037	037	037	037
			CRHEATER324A00	6.5	4.9/6.0	16.7/20.4	037	037	037	037
	CRHEATER325A00		8.7	6.5/8.0	22.3/27.3	037	037	037	037	
	CRHEATER326A00		10.5	7.9/9.6	26.9/32.9	037	037	037	037	
	CRHEATER328A00		16.0	12.0/14.7	41.0/50.1	038	038	038	038	
	460-3-60	STD	CRHEATER333A00	6.0	5.5	18.8	—	—	—	—
			CRHEATER334A00	8.8	8.1	27.6	—	—	—	—
			CRHEATER335A00	11.5	10.6	36.0	—	—	—	—
			CRHEATER336A00	14.0	12.9	43.9	—	—	—	—
		MED	CRHEATER333A00	6.0	5.5	18.8	—	—	—	—
CRHEATER334A00			8.8	8.1	27.6	—	—	—	—	
CRHEATER335A00			11.5	10.6	36.0	—	—	—	—	
CRHEATER336A00			14.0	12.9	43.9	—	—	—	—	
HIGH		CRHEATER333A00	6.0	5.5	18.8	—	—	—	—	
		CRHEATER334A00	8.8	8.1	27.6	—	—	—	—	
		CRHEATER335A00	11.5	10.6	36.0	—	—	—	—	
		CRHEATER336A00	14.0	12.9	43.9	—	—	—	—	
575-3-60	STD	CRHEATER339A00	10.0	9.2	31.3	—	—	—	—	
		CRHEATER340A00	15.0	13.8	47.0	—	—	—	—	
	MED	CRHEATER339A00	10.0	9.2	31.3	—	—	—	—	
		CRHEATER340A00	15.0	13.8	47.0	—	—	—	—	
	HIGH	CRHEATER339A00	10.0	9.2	31.3	—	—	—	—	
		CRHEATER340A00	15.0	13.8	47.0	—	—	—	—	

50GCQ*05 Electric Heat Data — without Non-Fused Disconnect

50GCQ UNIT SIZE	NOM. V-Ph-Hz	IFM TYPE	ELECTRIC HEATER PART NUMBER	NOM (kW)	APPLICATION (kW)	APPLICATION OUTPUT (MBH)	SINGLE POINT OR JUNCTION KIT PART NUMBER CRSINGLEXXA00					
							No C.O.or Unpowered C.O.		With Pwr'd C.O.			
							No P.E.	With P.E. (pwr'd fr/unit)	No P.E.	With P.E. (pwr'd fr/unit)		
T05	208/230-1-60	STD	CRHEATER323A00	4.4	3.3/4.0	11.3/13.8	040	040	—	—		
			CRHEATER325A00	8.7	6.5/8.0	22.3/27.3	040	040	—	—		
			CRHEATER327A00	13.0	9.8/11.9	33.3/40.7	041	041	—	—		
			CRHEATER329A00	17.4	13.1/16.0	44.6/54.5	041	041	—	—		
			CRHEATER330A00	19.2	14.4/17.6	49.2/60.2	041	041	—	—		
			CRHEATER331A00	21.0	15.8/19.3	53.8/65.8	041	041	—	—		
		MED	CRHEATER326A00	10.5	7.9/9.6	26.9/32.9	040	040	—	—		
			CRHEATER323A00	4.4	3.3/4.0	11.3/13.8	040	040	—	—		
			CRHEATER325A00	8.7	6.5/8.0	22.3/27.3	040	040	—	—		
			CRHEATER327A00	13.0	9.8/11.9	33.3/40.7	041	041	—	—		
			CRHEATER329A00	17.4	13.1/16.0	44.6/54.5	041	041	—	—		
			CRHEATER330A00	19.2	14.4/17.6	49.2/60.2	041	041	—	—		
		HIGH	CRHEATER331A00	21.0	15.8/19.3	53.8/65.8	041	041	—	—		
			CRHEATER326A00	10.5	7.9/9.6	26.9/32.9	040	040	—	—		
			CRHEATER323A00	4.4	3.3/4.0	11.3/13.8	040	040	—	—		
			CRHEATER325A00	8.7	6.5/8.0	22.3/27.3	040	040	—	—		
			CRHEATER327A00	13.0	9.8/11.9	33.3/40.7	041	041	—	—		
			CRHEATER329A00	17.4	13.1/16.0	44.6/54.5	041	041	—	—		
		J05	208/230-3-60	STD	CRHEATER323A00	4.4	3.3/4.0	11.3/13.8	—	—	—	—
					CRHEATER324A00	6.5	4.9/6.0	16.7/20.4	—	—	—	037
					CRHEATER325A00	8.7	6.5/8.0	22.3/27.3	037	037	037	037
					CRHEATER328A00	16.0	12.0/14.7	41.0/50.1	038	038	038	038
					CRHEATER330A00	19.2	14.4/17.6	49.2/60.2	039	039	039	039
					CRHEATER331A00	21.0	15.8/19.3	53.8/65.8	039	039	039	039
MED	CRHEATER326A00			10.5	7.9/9.6	26.9/32.9	037	037	038	038		
	CRHEATER323A00			4.4	3.3/4.0	11.3/13.8	—	—	—	—		
	CRHEATER324A00			6.5	4.9/6.0	16.7/20.4	—	—	037	037		
	CRHEATER325A00			8.7	6.5/8.0	22.3/27.3	037	037	037	037		
	CRHEATER328A00			16.0	12.0/14.7	41.0/50.1	038	038	038	038		
	CRHEATER330A00			19.2	14.4/17.6	49.2/60.2	039	039	039	039		
HIGH	CRHEATER331A00			21.0	15.8/19.3	53.8/65.8	039	039	039	039		
	CRHEATER326A00			10.5	7.9/9.6	26.9/32.9	037	037	038	038		
	CRHEATER323A00			4.4	3.3/4.0	11.3/13.8	—	—	—	—		
	CRHEATER324A00			6.5	4.9/6.0	16.7/20.4	—	—	—	037		
	CRHEATER325A00			8.7	6.5/8.0	22.3/27.3	037	037	037	037		
	CRHEATER328A00			16.0	12.0/14.7	41.0/50.1	038	038	038	038		
460-3-60	STD			CRHEATER330A00	19.2	14.4/17.6	49.2/60.2	039	039	039	039	
				CRHEATER331A00	21.0	15.8/19.3	53.8/65.8	039	039	039	039	
				CRHEATER326A00	10.5	7.9/9.6	26.9/32.9	037	037	038	038	
				CRHEATER337A00	21.5	19.7	67.4	037	037	037	037	
	MED			CRHEATER333A00	6.0	5.5	18.8	—	—	—	—	
				CRHEATER335A00	11.5	10.6	36.0	—	—	—	—	
		CRHEATER336A00	14.0	12.9	43.9	—	—	—	—			
		CRHEATER337A00	21.5	19.7	67.4	037	037	037	037			
	HIGH	CRHEATER333A00	6.0	5.5	18.8	—	—	—	—			
		CRHEATER335A00	11.5	10.6	36.0	—	—	—	—			
		CRHEATER336A00	14.0	12.9	43.9	—	—	—	—			
		CRHEATER337A00	21.5	19.7	67.4	037	037	037	037			
575-3-60	STD	CRHEATER333A00	6.0	5.5	18.8	—	—	—	—			
		CRHEATER335A00	11.5	10.6	36.0	—	—	—	—			
	MED	CRHEATER336A00	14.0	12.9	43.9	—	—	—	—			
		CRHEATER339A00	10.0	9.2	31.3	—	—	—	—			
	HIGH	CRHEATER340A00	15.0	13.8	47.0	—	—	—	—			
		CRHEATER339A00	10.0	9.2	31.3	—	—	—	—			

50GCQ*05 Electric Heat Data — with Non-Fused Disconnect

50GCQ UNIT SIZE	NOM. V-Ph-Hz	IFM TYPE	ELECTRIC HEATER PART NUMBER	NOM (kW)	APPLICATION (kW)	APPLICATION OUTPUT (MBH)	SINGLE POINT OR JUNCTION KIT PART NUMBER CRSINGLEXXXXA00					
							No C.O.or Unpowered C.O.		With Pwr'd C.O.			
							No P.E.	With P.E. (pwr'd fr/unit)	No P.E.	With P.E. (pwr'd fr/unit)		
T05	208/230-1-60	STD	CRHEATER323A00	4.4	3.3/4.0	11.3/13.8	040	040	—	—		
			CRHEATER325A00	8.7	6.5/8.0	22.3/27.3	040	040	—	—		
			CRHEATER327A00	13.0	9.8/11.9	33.3/40.7	041	041	—	—		
			CRHEATER329A00	17.4	13.1/16.0	44.6/54.5	041	041	—	—		
			CRHEATER330A00	19.2	14.4/17.6	49.2/60.2	041	041	—	—		
			CRHEATER331A00	21.0	15.8/19.3	53.8/65.8	041	041	—	—		
		MED	CRHEATER326A00	10.5	7.9/9.6	26.9/32.9	040	040	—	—		
			CRHEATER323A00	4.4	3.3/4.0	11.3/13.8	040	040	—	—		
			CRHEATER325A00	8.7	6.5/8.0	22.3/27.3	040	040	—	—		
			CRHEATER327A00	13.0	9.8/11.9	33.3/40.7	041	041	—	—		
			CRHEATER329A00	17.4	13.1/16.0	44.6/54.5	041	041	—	—		
			CRHEATER330A00	19.2	14.4/17.6	49.2/60.2	041	041	—	—		
		HIGH	CRHEATER331A00	21.0	15.8/19.3	53.8/65.8	041	041	—	—		
			CRHEATER326A00	10.5	7.9/9.6	26.9/32.9	040	040	—	—		
			CRHEATER323A00	4.4	3.3/4.0	11.3/13.8	040	040	—	—		
			CRHEATER325A00	8.7	6.5/8.0	22.3/27.3	040	040	—	—		
			CRHEATER327A00	13.0	9.8/11.9	33.3/40.7	041	041	—	—		
			CRHEATER329A00	17.4	13.1/16.0	44.6/54.5	041	041	—	—		
		J05	208/230-3-60	STD	CRHEATER323A00	4.4	3.3/4.0	11.3/13.8	037	037	037	037
					CRHEATER324A00	6.5	4.9/6.0	16.7/20.4	037	037	037	037
					CRHEATER325A00	8.7	6.5/8.0	22.3/27.3	037	037	037	037
					CRHEATER328A00	16.0	12.0/14.7	41.0/50.1	038	038	038	038
					CRHEATER330A00	19.2	14.4/17.6	49.2/60.2	039	039	039	039
					CRHEATER331A00	21.0	15.8/19.3	53.8/65.8	039	039	039	039
MED	CRHEATER326A00			10.5	7.9/9.6	26.9/32.9	037	037	038	038		
	CRHEATER323A00			4.4	3.3/4.0	11.3/13.8	037	037	037	037		
	CRHEATER324A00			6.5	4.9/6.0	16.7/20.4	037	037	037	037		
	CRHEATER325A00			8.7	6.5/8.0	22.3/27.3	037	037	037	037		
	CRHEATER328A00			16.0	12.0/14.7	41.0/50.1	038	038	038	038		
	CRHEATER330A00			19.2	14.4/17.6	49.2/60.2	039	039	039	039		
HIGH	CRHEATER331A00			21.0	15.8/19.3	53.8/65.8	039	039	039	039		
	CRHEATER326A00			10.5	7.9/9.6	26.9/32.9	037	038	038	038		
	CRHEATER323A00			4.4	3.3/4.0	11.3/13.8	037	037	037	037		
	CRHEATER324A00			6.5	4.9/6.0	16.7/20.4	037	037	037	037		
	CRHEATER325A00			8.7	6.5/8.0	22.3/27.3	037	037	037	037		
	CRHEATER328A00			16.0	12.0/14.7	41.0/50.1	038	038	038	038		
460-3-60	STD		CRHEATER330A00	19.2	14.4/17.6	49.2/60.2	039	039	039	039		
			CRHEATER331A00	21.0	15.8/19.3	53.8/65.8	039	039	039	039		
			CRHEATER337A00	21.5	19.7	67.4	037	037	037	037		
			CRHEATER333A00	6.0	5.5	18.8	—	—	—	—		
	MED		CRHEATER335A00	11.5	10.6	36.0	—	—	—	—		
			CRHEATER336A00	14.0	12.9	43.9	—	—	—	—		
		CRHEATER337A00	21.5	19.7	67.4	037	037	037	037			
		CRHEATER333A00	6.0	5.5	18.8	—	—	—	—			
	HIGH	CRHEATER335A00	11.5	10.6	36.0	—	—	—	—			
		CRHEATER336A00	14.0	12.9	43.9	—	—	—	—			
		CRHEATER337A00	21.5	19.7	67.4	037	037	037	037			
		CRHEATER333A00	6.0	5.5	18.8	—	—	—	—			
575-3-60	STD	CRHEATER339A00	10.0	9.2	31.3	—	—	—	—			
		CRHEATER340A00	15.0	13.8	47.0	—	—	—	—			
	MED	CRHEATER339A00	10.0	9.2	31.3	—	—	—	—			
		CRHEATER340A00	15.0	13.8	47.0	—	—	—	—			
	HIGH	CRHEATER339A00	10.0	9.2	31.3	—	—	—	—			
		CRHEATER340A00	15.0	13.8	47.0	—	—	—	—			

50GCQ*06 Electric Heat Data — without Non-Fused Disconnect

50GCQ UNIT SIZE	NOM. V-Ph-Hz	IFM TYPE	ELECTRIC HEATER PART NUMBER	NOM (kW)	APPLICATION (kW)	APPLICATION OUTPUT (MBH)	SINGLE POINT OR JUNCTION KIT PART NUMBER CRSINGLEXXXXA00			
							No C.O. or Unpowered C.O.		With Pwr'd C.O.	
							No P.E.	With P.E. (pwr'd fr/unit)	No P.E.	With P.E. (pwr'd fr/unit)
T06	208/230-1-60	STD	CRHEATER324A00	6.5	4.9/6.0	16.7/20.4	040	040	—	—
			CRHEATER325A00	8.7	6.5/8.0	22.3/27.3	040	040	—	—
			CRHEATER327A00	13.0	9.8/11.9	33.3/40.7	041	041	—	—
			CRHEATER329A00	17.4	13.1/16.0	44.6/54.5	041	041	—	—
			CRHEATER331A00	21.0	15.8/19.3	53.8/65.8	041	041	—	—
		MED	CRHEATER324A00	6.5	4.9/6.0	16.7/20.4	040	040	—	—
			CRHEATER325A00	8.7	6.5/8.0	22.3/27.3	040	040	—	—
			CRHEATER327A00	13.0	9.8/11.9	33.3/40.7	041	041	—	—
			CRHEATER329A00	17.4	13.1/16.0	44.6/54.5	041	041	—	—
			CRHEATER331A00	21.0	15.8/19.3	53.8/65.8	041	041	—	—
J06	208/230-3-60	STD	CRHEATER324A00	6.5	4.9/6.0	16.7/20.4	—	037	037	037
			CRHEATER326A00	10.5	7.9/9.6	26.9/32.9	038	038	038	038
			CRHEATER328A00	16.0	12.0/14.7	41.0/50.1	038	038	038	038
			CRHEATER331A00	21.0	15.8/19.3	53.8/65.8	039	039	039	039
			CRHEATER332A00	24.5	18.4/22.5	62.8/76.8	039	039	039	039
		MED	CRHEATER324A00	6.5	4.9/6.0	16.7/20.4	037	037	037	037
			CRHEATER326A00	10.5	7.9/9.6	26.9/32.9	038	038	038	038
			CRHEATER328A00	16.0	12.0/14.7	41.0/50.1	038	038	038	038
			CRHEATER331A00	21.0	15.8/19.3	53.8/65.8	039	039	039	039
			CRHEATER332A00	24.5	18.4/22.5	62.8/76.8	039	039	039	039
		HIGH	CRHEATER324A00	6.5	4.9/6.0	16.7/20.4	—	037	037	037
			CRHEATER326A00	10.5	7.9/9.6	26.9/32.9	038	038	038	038
			CRHEATER328A00	16.0	12.0/14.7	41.0/50.1	038	038	038	038
			CRHEATER331A00	21.0	15.8/19.3	53.8/65.8	039	039	039	039
			CRHEATER332A00	24.5	18.4/22.5	62.8/76.8	039	039	039	039
	460-3-60	STD	CRHEATER333A00	6.0	5.5	18.8	—	—	—	—
			CRHEATER335A00	11.5	10.6	36.0	—	—	—	—
			CRHEATER336A00	14.0	12.9	43.9	—	—	—	—
			CRHEATER337A00	21.5	19.7	67.4	037	037	037	037
			CRHEATER338A00	24.0	22.0	75.2	037	037	037	037
MED		CRHEATER333A00	6.0	5.5	18.8	—	—	—	—	
		CRHEATER335A00	11.5	10.6	36.0	—	—	—	—	
		CRHEATER336A00	14.0	12.9	43.9	—	—	—	—	
		CRHEATER337A00	21.5	19.7	67.4	037	037	037	037	
		CRHEATER338A00	24.0	22.0	75.2	037	037	037	037	
HIGH		CRHEATER333A00	6.0	5.5	18.8	—	—	—	—	
		CRHEATER335A00	11.5	10.6	36.0	—	—	—	—	
		CRHEATER336A00	14.0	12.9	43.9	—	—	—	—	
		CRHEATER337A00	21.5	19.7	67.4	037	037	037	037	
		CRHEATER338A00	24.0	22.0	75.2	037	037	037	037	
575-3-60	STD	CRHEATER340A00	15.0	13.8	47.0	—	—	—	—	
		CRHEATER341A00	21.0	19.3	65.8	037	037	037	037	
	MED	CRHEATER340A00	15.0	13.8	47.0	—	—	—	—	
		CRHEATER341A00	21.0	19.3	65.8	037	037	037	037	
	HIGH	CRHEATER340A00	15.0	13.8	47.0	—	—	—	—	
		CRHEATER341A00	21.0	19.3	65.8	037	037	037	037	

50GCQ*06 Electric Heat Data — with Non-Fused Disconnect

50GCQ UNIT SIZE	NOM. V-Ph-Hz	IFM TYPE	ELECTRIC HEATER PART NUMBER	NOM (kW)	APPLICATION (kW)	APPLICATION OUTPUT (MBH)	SINGLE POINT OR JUNCTION KIT PART NUMBER CRSINGLEXXXXA00			
							No C.O. or Unpowered C.O.		With Pwr'd C.O.	
							No P.E.	With P.E. (pwr'd fr/unit)	No P.E.	With P.E. (pwr'd fr/unit)
T06	208/230-1-60	STD	CRHEATER324A00	6.5	4.9/6.0	16.7/20.4	040	040	—	—
			CRHEATER325A00	8.7	6.5/8.0	22.3/27.3	040	040	—	—
			CRHEATER327A00	13.0	9.8/11.9	33.3/40.7	041	041	—	—
			CRHEATER329A00	17.4	13.1/16.0	44.6/54.5	041	041	—	—
			CRHEATER331A00	21.0	15.8/19.3	53.8/65.8	041	041	—	—
		MED	CRHEATER324A00	6.5	4.9/6.0	16.7/20.4	040	040	—	—
			CRHEATER325A00	8.7	6.5/8.0	22.3/27.3	040	040	—	—
			CRHEATER327A00	13.0	9.8/11.9	33.3/40.7	041	041	—	—
			CRHEATER329A00	17.4	13.1/16.0	44.6/54.5	041	041	—	—
			CRHEATER331A00	21.0	15.8/19.3	53.8/65.8	041	041	—	—
J06	208/230-3-60	STD	CRHEATER324A00	6.5	4.9/6.0	16.7/20.4	037	037	037	037
			CRHEATER326A00	10.5	7.9/9.6	26.9/32.9	038	038	038	038
			CRHEATER328A00	16.0	12.0/14.7	41.0/50.1	038	038	038	038
			CRHEATER331A00	21.0	15.8/19.3	53.8/65.8	039	039	039	039
			CRHEATER332A00	24.5	18.4/22.5	62.8/76.8	039	039	039	039
		MED	CRHEATER324A00	6.5	4.9/6.0	16.7/20.4	037	037	037	037
			CRHEATER326A00	10.5	7.9/9.6	26.9/32.9	038	038	038	038
			CRHEATER328A00	16.0	12.0/14.7	41.0/50.1	038	038	038	038
			CRHEATER331A00	21.0	15.8/19.3	53.8/65.8	039	039	039	039
			CRHEATER332A00	24.5	18.4/22.5	62.8/76.8	039	039	039	039
		HIGH	CRHEATER324A00	6.5	4.9/6.0	16.7/20.4	037	037	037	037
			CRHEATER326A00	10.5	7.9/9.6	26.9/32.9	038	038	038	038
			CRHEATER328A00	16.0	12.0/14.7	41.0/50.1	038	038	038	038
			CRHEATER331A00	21.0	15.8/19.3	53.8/65.8	039	039	039	039
			CRHEATER332A00	24.5	18.4/22.5	62.8/76.8	039	039	039	039
	460-3-60	STD	CRHEATER333A00	6.0	5.5	18.8	—	—	—	—
			CRHEATER335A00	11.5	10.6	36.0	—	—	—	—
			CRHEATER336A00	14.0	12.9	43.9	—	—	—	—
			CRHEATER337A00	21.5	19.7	67.4	037	037	037	037
			CRHEATER338A00	24.0	22.0	75.2	037	037	037	037
MED		CRHEATER333A00	6.0	5.5	18.8	—	—	—	—	
		CRHEATER335A00	11.5	10.6	36.0	—	—	—	—	
		CRHEATER336A00	14.0	12.9	43.9	—	—	—	—	
		CRHEATER337A00	21.5	19.7	67.4	037	037	037	037	
		CRHEATER338A00	24.0	22.0	75.2	037	037	037	037	
HIGH		CRHEATER333A00	6.0	5.5	18.8	—	—	—	—	
		CRHEATER335A00	11.5	10.6	36.0	—	—	—	—	
		CRHEATER336A00	14.0	12.9	43.9	—	—	—	—	
		CRHEATER337A00	21.5	19.7	67.4	037	037	037	037	
		CRHEATER338A00	24.0	22.0	75.2	037	037	037	037	
575-3-60	STD	CRHEATER340A00	15.0	13.8	47.0	—	—	—	—	
		CRHEATER341A00	21.0	19.3	65.8	037	037	037	037	
	MED	CRHEATER340A00	15.0	13.8	47.0	—	—	—	—	
		CRHEATER341A00	21.0	19.3	65.8	037	037	037	037	
	HIGH	CRHEATER340A00	15.0	13.8	47.0	—	—	—	—	
		CRHEATER341A00	21.0	19.3	65.8	037	037	037	037	

Typical Control Wiring Diagram — 50GCQ*04-06 208/230-3-60 Unit with Electromechanical Control and POL224 Economizer

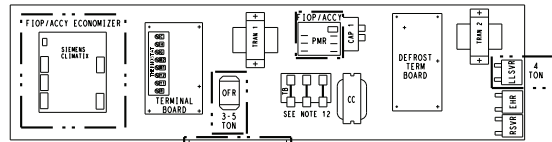

COMPONENT ARRANGEMENT

- NOTES:
1. TERMINAL BOARD SCHEMATIC LAYOUT DOES NOT MATCH ACTUAL TERMINAL BOARD LAYOUT.
 2. TERMINAL BOARD JUMPERS 1, 2 AND 3 ARE CUT FOR HEATPUMP UNITS.
 3. REMOVE DESIGNATED JUMPERS ON TERMINAL BOARD WHEN ADDING SMOKE DETECTORS, OCCUPANCY AND REMOTE SHUTDOWN.
 4. USE ABC AS COURSE AND AS POT FINE ADJUSTMENTS FOR SETTING HIGH FAN SPEED. LOW SPEED IS AN OFFSET BASED ON DIP SWITCHES.
 5. 2-PIN LOW SPEED DIP SWITCH POSITIONS ARE FACTORY SET AS SHOWN.
 6. HARDSHIFT AND CUTOFF SET TO "MIN". JUMPER PIN ON TOP 2-PINS AS SHOWN.
 7. THE * WIRE COLOR IS FOR IDENTIFICATION WITHIN THIS SCHEMATIC.
 8. COMPRESSOR LEADER PLUS CONTAINS BRIDGE RECTIFIER TO CONVERT AC TO DC.
 9. T84 LOCATED IN HEAT SECTION.
 10. TO CONVERT TO A SINGLE STAGE HEATER MOVE VIOLET WIRE AT T84 TO CONNECT WITH WHITE WIRE.
 11. ON 3 & 5 TON UNITS, PNK FROM HPC CONNECTS DIRECTLY TO YEL FROM PIN 12.
 12. 3 PINS TO SHOWN. COMPONENTS MAY VARY BASED ON EXACT PRODUCT & OPTIONS.
 13. FPT IS STANDARD FOR HEATPUMP (NOT OPTIONAL), EXCEPT 7-11 (COLEX) CONTROL DOES NOT USE FPT.

HP DIP SWITCH SETTINGS

- (DEFAULT)
- 30 MINUTES 60 MINUTES 90 MINUTES 120 MINUTES
- FIELD SELECTABLE OPTIONS FOR TIME PERIOD BETWEEN DEFROST CYCLES (MINUTES):
- SPEED UP JUMPED TEST PINS (USE UP) METAL OBJECT FIELD
- 1) MOMENTARILY SHORT PINS AND RELEASE TO BYPASS COMPRESSOR OFF DELAY
 - 2) SHORT FOR 1-10 SEC. AND RELEASE FOR FORCED DEFROST.
 - 3) PERMANENT SHORT WILL BE IGNORED. DEFROST WILL TERMINATE IN 90 SEC. IF DFT IS OPEN. DEFROST WILL TERMINATE NORMALLY IF DFT IS CLOSED.

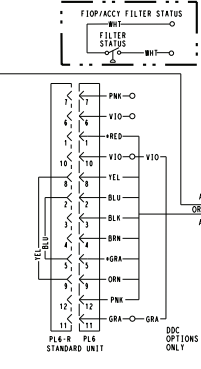
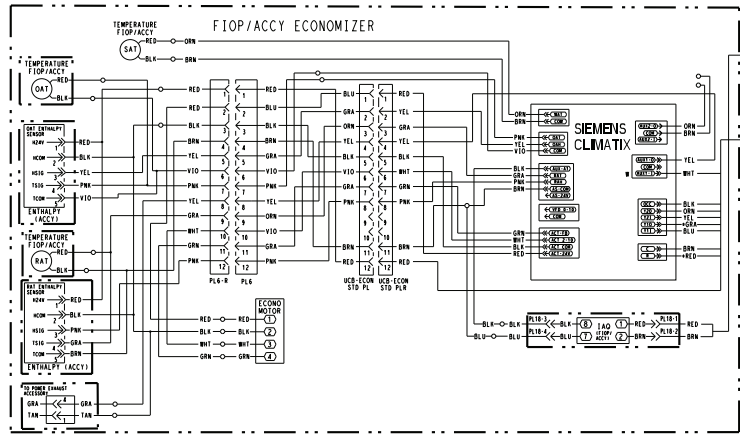
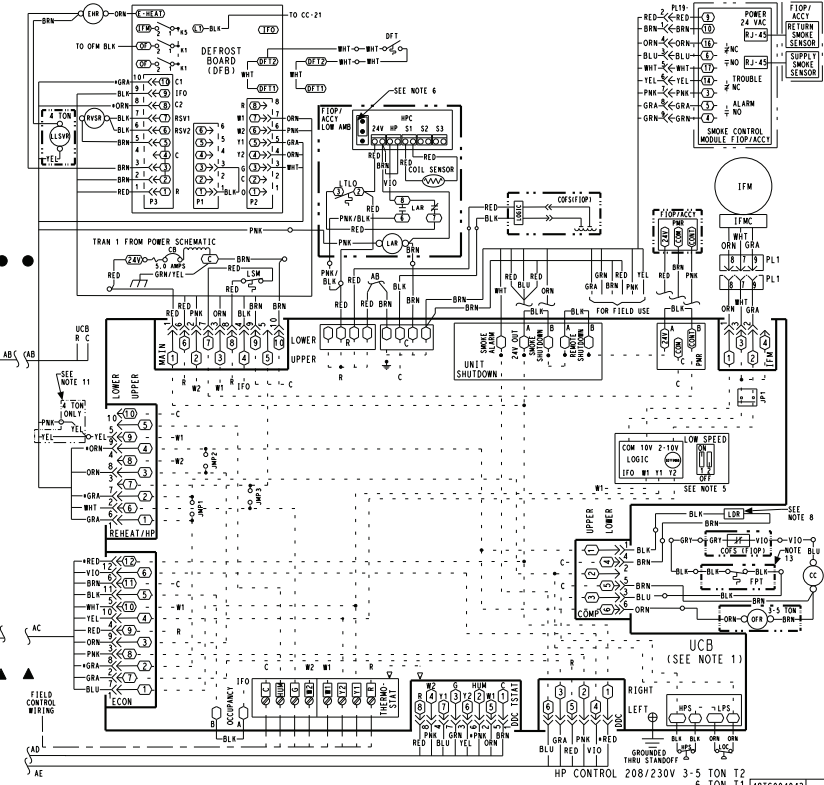
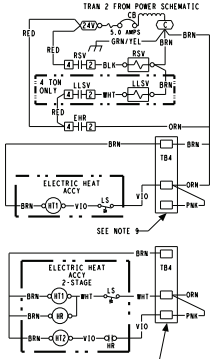

Typical Control Wiring Diagram — 50GCQ*04-06 460/575-3-60 Unit with Electromechanical Control and POL224 Economizer

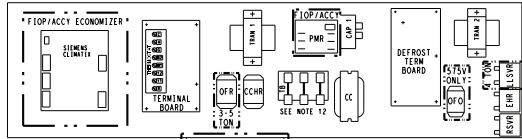

COMPONENT ARRANGEMENT

HACR/DISCONNECT OPTION

- NOTES:**
1. TERMINAL BOARD SCHEMATIC LAYOUT DOES NOT MATCH ACTUAL TERMINAL BOARD LAYOUT.
 2. TERMINAL BOARD JUMPERS 1, 2 AND 3 ARE CUT FOR REHEAT UNITS ONLY.
 3. REMOVE DESIGNATED JUMPERS ON TERMINAL BOARD WHEN ADDING SMOKE DETECTORS, OCCUPANCY AND REMOTE SHUTDOWN.
 4. USE ABC AS COURSE AND POT AS FINE ADJUSTMENTS FOR SETTING HIGH FAN SPEED. LOW SPEED IS AN OFFSET BASED ON DIP SWITCHES.
 5. 2-PIN LOW SPEED DIP SWITCH POSITIONS ARE FACTORY SET AS SHOWN.
 6. HARSHSTART AND CUTOFF SET TO "MIN". JUMPER PIN ON TOP 2-PINS AS SHOWN.
 7. THE * WIRE COLOR IS FOR DIFFERENTIATION WITHIN THIS SCHEMATIC.
 8. COMPRESSOR LOADER PLUS CONTAINS BRIDGE RECTIFIER TO CONVERT AC TO DC.
 9. T84 LOCATED IN HEAT SECTION.
 10. TO CONVERT TO A SINGLE STAGE HEATER MOVE VIOLET WIRE AT T84 TO CONNECT WITH WHITE WIRE.
 11. ON 3 & 5 TON UNITS, PWR FROM HPC CONNECTS DIRECTLY TO YEL FROM PIN 3.
 12. COMPONENTS MAY VARY BASED ON EACH PRODUCT AND OPTIONS.
 13. FPT IS STANDARD FOR HEATPUMP (NOT OPTIONAL), EXCEPT T-11 (10X/PL) CONTROL DOES NOT USE FPT.

HP DIP SWITCH SETTINGS

(DEFAULT) 30 MINUTES 60 MINUTES 90 MINUTES 120 MINUTES

FIELD SELECTABLE OPTIONS FOR TIME PERIOD BETWEEN DEFROST CYCLES (MINUTES):

FIELD SELECTABLE OPTIONS FOR SPEED UP CYCLE: MOMENTARILY SHORT PINS AND RELEASE TO BYPASS COMPRESSOR OFF DELAY

1. MOMENTARILY SHORT PINS AND RELEASE TO BYPASS COMPRESSOR OFF DELAY
2. SHORT FOR 1-10 SEC. AND RELEASE FOR FORCED DEFROST.
3. PERMANENT SHORT WILL BE IGNORED. DEFROST WILL TERMINATE IN 30 SEC. IF DFT IS OPEN. DEFROST WILL TERMINATE NORMALLY IF DFT IS CLOSED.

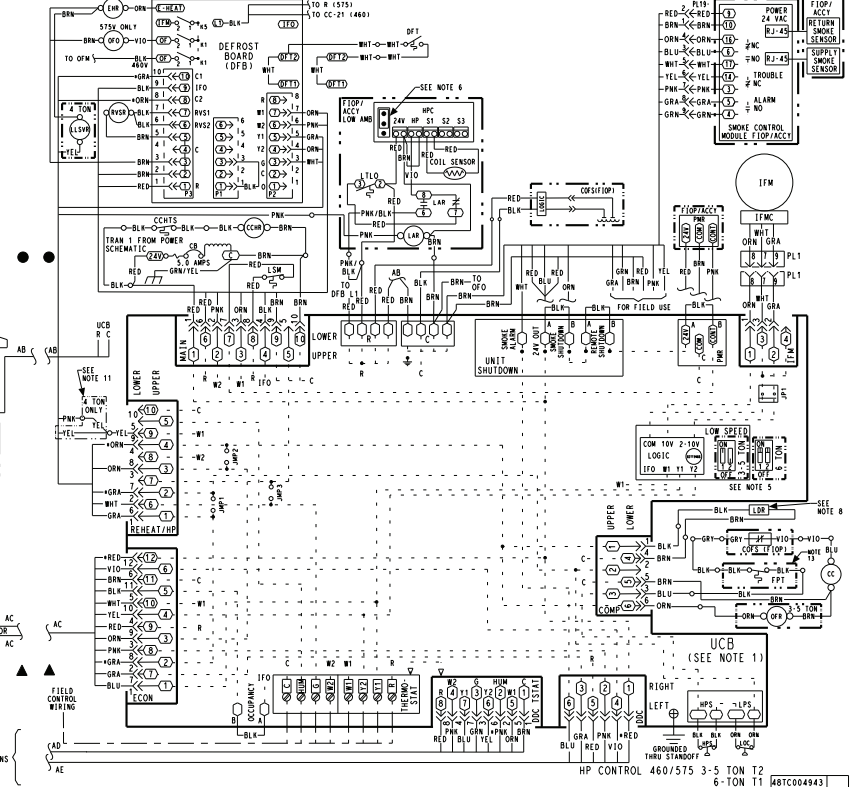
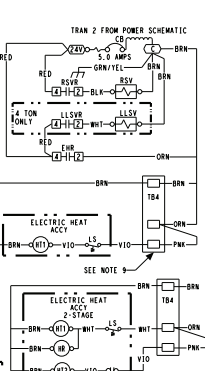
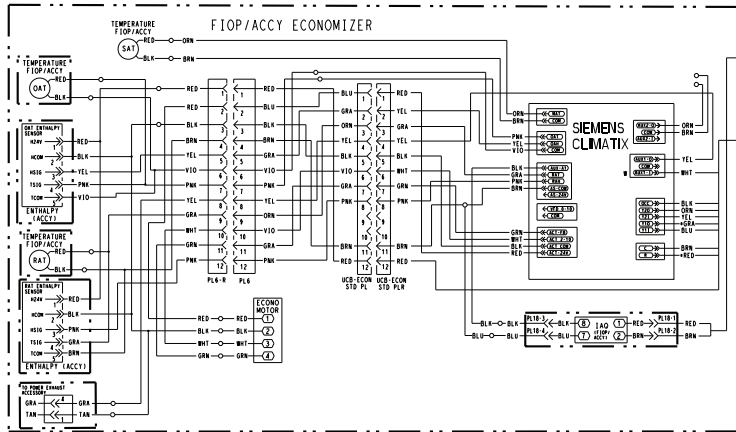

Typical Control Wiring Diagram — 50GCQ*04-06 208/230, 460, 575-3-60 Unit with SystemVu™ Controller

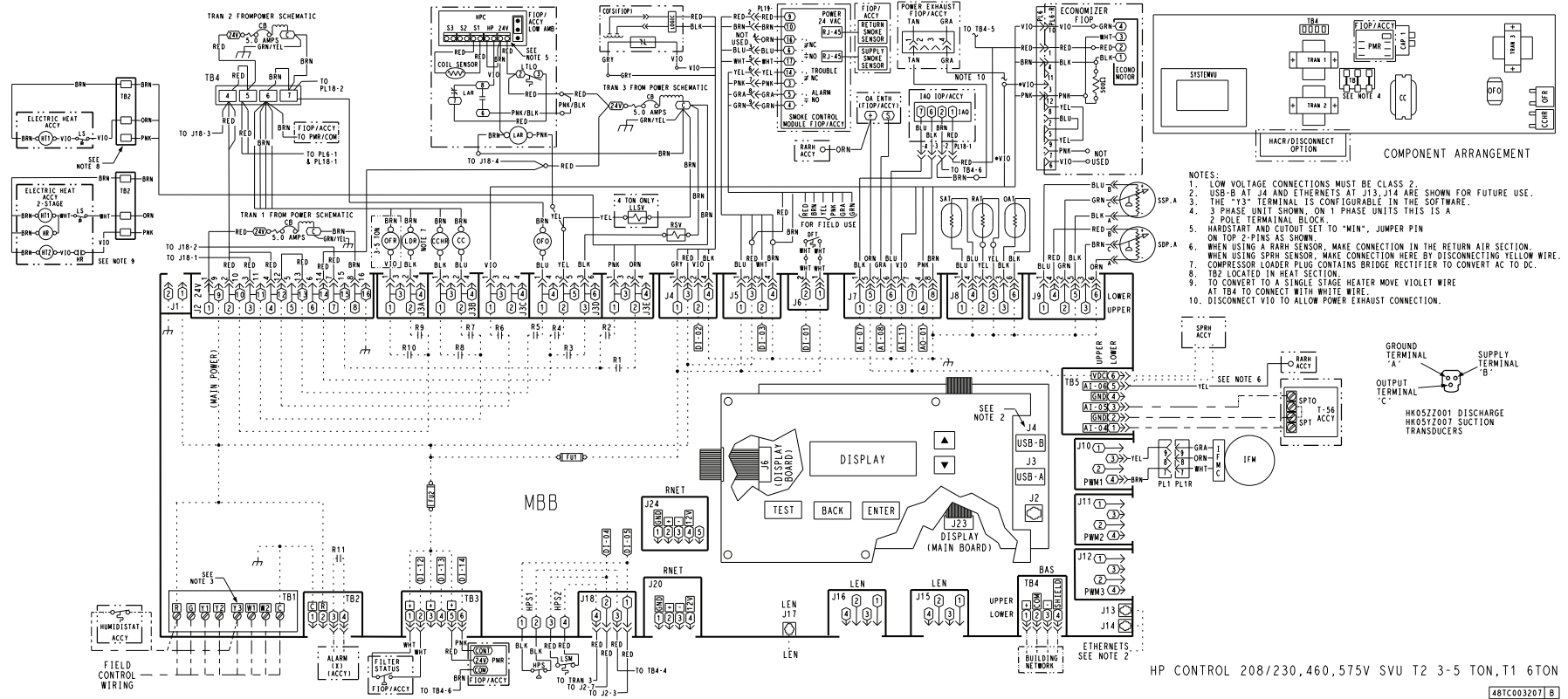

- NOTES:**
1. LOW VOLTAGE CONNECTIONS MUST BE CLASS 2.
 2. USB-B AT J4 AND ETHERNETS AT J11, J14 ARE SHOWN FOR FUTURE USE.
 3. THE "Y3" TERMINAL IS CONFIGURABLE IN THE SOFTWARE.
 4. 3 PHASE UNIT SHOWN. ON 1 PHASE UNITS THIS IS A 2 POLE TERMINAL BLOCK.
 5. HARDSTART AND CUTOFF SET TO "MIN". JUMPER PIN ON TOP 2-PINS AS SHOWN.
 6. WHEN USING A RARH SENSOR, MAKE CONNECTION IN THE RETURN AIR SECTION. WHEN USING SPN SENSOR, MAKE CONNECTION HERE BY DISCONNECTING YELLOW WIRE.
 7. COMPRESSOR LOADER PLUG CONTAINS BRIDGE RECTIFIER TO CONVERT AC TO DC.
 8. TB2 LOCATED IN HEAT SECTION.
 9. TO CONVERT TO A SINGLE STAGE HEATER MOVE VIOLET WIRE AT TB4 TO CONNECT WITH WHITE WIRE.
 10. DISCONNECT VIO TO ALLOW POWER EXHAUST CONNECTION.

HP CONTROL 208/230,460,575V SVU T2 3-5 TON, T1 6TON
48TC0032071 B



Typical Control Wiring Diagram — 50GCQ*04-06 208/230-3-60 Unit with RTU Open Controller

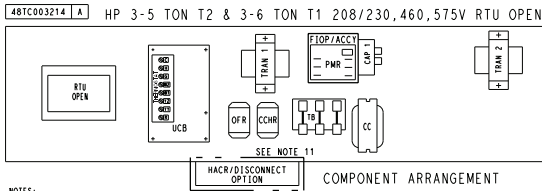

- NOTES:
- TERMINAL BOARD SCHEMATIC LAYOUT DOES NOT MATCH ACTUAL TERMINAL BOARD LAYOUT.
 - TERMINAL BOARD JUMPERS 1, 2 AND 3 ARE CUT FOR REHEAT UNITS ONLY.
 - REMOVE DESIGNATED JUMPERS ON TERMINAL BOARD WHEN ADDING SMOKE DETECTORS, OCCUPANCY AND REMOTE SHUTDOWN.
 - NOT USED ON RTU OPEN.
 - USE RTU OPEN SETTINGS TO ADJUST FAN SPEED.
 - HARDSTART AND CUTOFF SET TO "MIN". JUMPER PIN ON TOP 2-PINS AS SHOWN.
 - TIC+ WIRE COLOR IS FOR DIFFERENTIATION WITHIN THIS SCHEMATIC.
 - COMPRESSOR LOADER PLUG CONTAINS BRIDGE RECTIFIER TO CONVERT AC TO DC.
 - T84 LOCATED IN THE HEAT SECTION.
 - TO CONVERT TO A SINGLE STAGE HEATER MOVE VIOLET WIRE AT T84 TO CONNECT WITH WHITE WIRE.
 - COMPONENTS MAY VARY BASED ON EXACT PRODUCT AND OPTIONS.
 - FOLLOW THIS WIRING FOR IFM CONNECTOR WITH RTU OPEN. IGNORE IFM WIRING AT UCB.

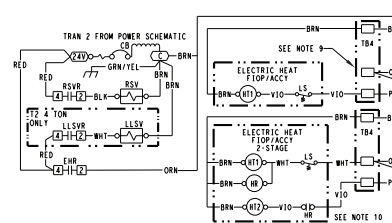

- FIELD SELECTABLE OPTIONS FOR TIME PERIOD BETWEEN DEFROST CYCLES (MINUTES).
- SPEED UP CYCLE
- JUMPERED TEST PINS (USE UP)
- MOMENTARILY SHORT PINS AND RELEASE TO BYPASS COMPRESSOR OFF DELAY
- 21 SHORT FOR 1-10 SEC. AND RELEASE FOR FORCED DEFROST. DEFROST WILL TERMINATE NORMALLY IF DFT IS OPEN. DEFROST WILL TERMINATE NORMALLY IF DFT IS CLOSED.
- 11 MOMENTARILY SHORT PINS AND RELEASE TO BYPASS COMPRESSOR OFF DELAY
- 21 SHORT FOR 1-10 SEC. AND RELEASE FOR FORCED DEFROST. DEFROST WILL TERMINATE NORMALLY IF DFT IS OPEN. DEFROST WILL TERMINATE NORMALLY IF DFT IS CLOSED.

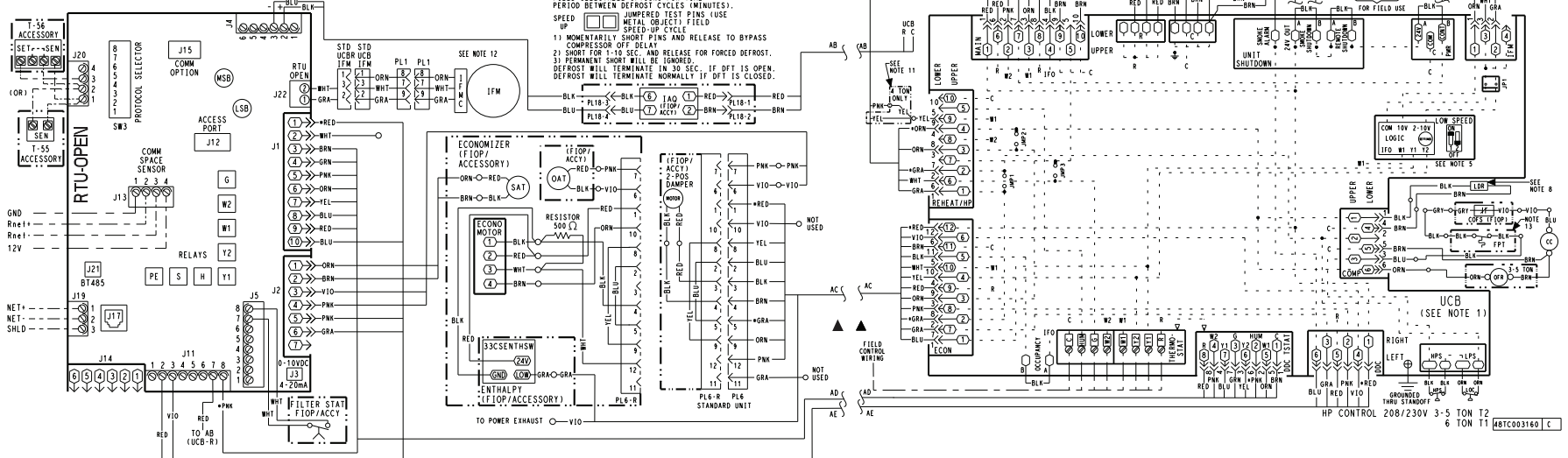

Typical Control Wiring Diagram — 50GCQ*04-06 460/575-3-60 Unit with RTU Open Controller

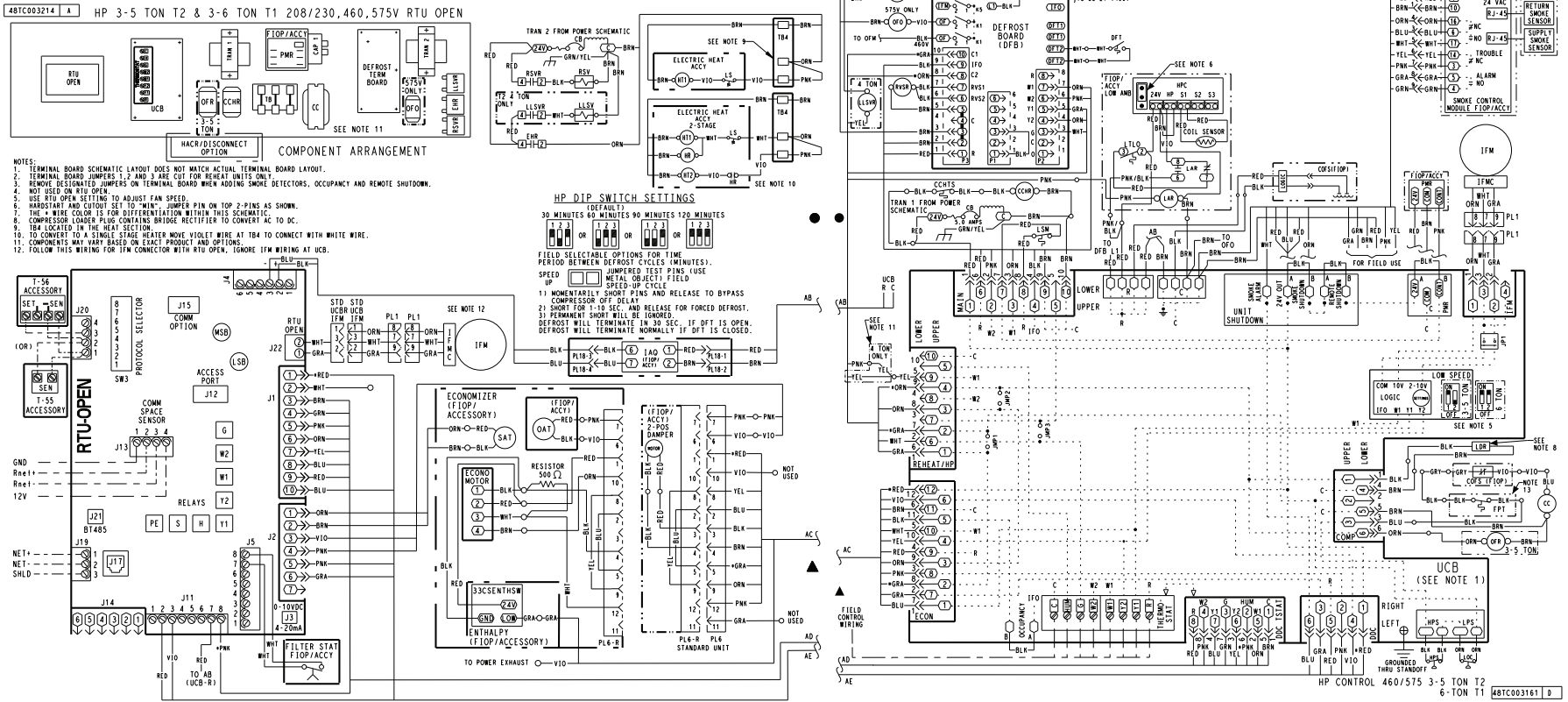

Typical 50GCQ*04-06 Power Wiring Diagram, 208/230-3-60 Unit Shown

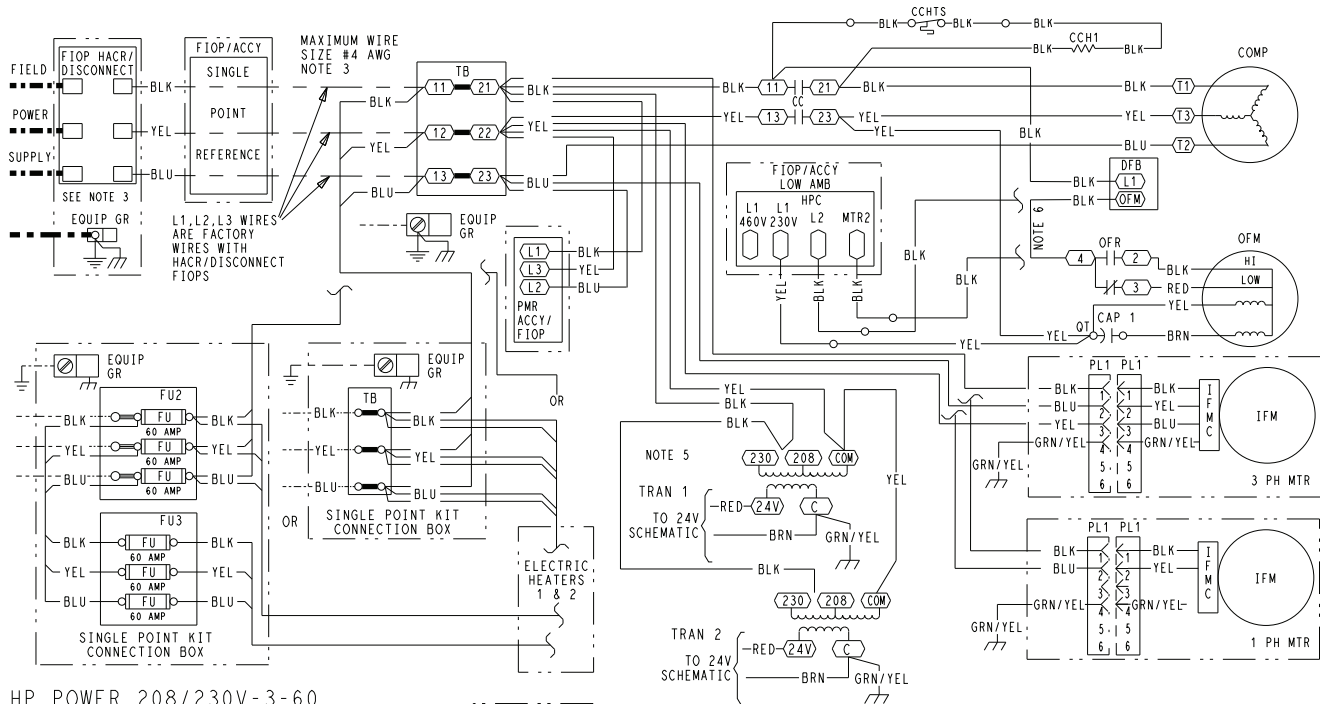

HP POWER 208/230V-3-60
3-5TON T2

NOTES

1. IF ANY OF THE ORIGINAL WIRE FURNISHED MUST BE REPLACED, IT MUST BE REPLACED WITH TYPE 90° C WIRE OR ITS EQUIVALENT.
2. COMPRESSOR AND FAN MOTORS ARE THERMALLY PROTECTED.
3. USE COPPER CONDUCTOR ONLY.
4. DO NOT DISCONNECT POWER PLUG OR SIGNAL WIRE WHILE UNDER LOAD.
5. ON 208/230V UNITS, TRAN IS WIRED FOR 230V. IF UNIT IS TO BE RUN WITH 208V POWER SUPPLY, DISCONNECT BLK WIRE FROM 230V TAP AND CONNECT TO 208V TAP.
6. THIS WIRE NOT USED WITH LOW AMBIENT FIOP/ACCY.

LEGEND

- MARKED WIRE
- TERMINAL (MARKED)
- TERMINAL (UNMARKED)
- TERMINAL BLOCK
- SPLICE
- SPLICE (MARKED)
- FACTORY WIRING
- FIELD CONTROL WIRING
- FIELD POWER WIRING
- CIRCUIT BOARD TRACE
- ACCESSORY OR OPTIONAL WIRING

- ACCY ACCESSORY
- AWG AMERICAN WIRE GAGE
- BAS BUILDING AUTOMATION NETWORK
- CC CONTACTOR, COMPRESSOR
- C COMMON
- CB CAPACITOR
- CH CRANKCASE HEATER
- CCHR CRANKCASE HEATER RELAY
- CCHTS CRANKCASE HEATER TEMP SWITCH
- CLO COMPRESSOR LOCKOUT
- CLV COOLING LIQUID VALVE
- COFS CONDENSATE OVERFLOW SWITCH
- COM SIGNAL COMMON
- COMP COMPRESSOR MOTOR
- DDC DIRECT DIGITAL CONTROL
- DFB DEFROST BOARD
- DFT DEFROST THERMOSTAT
- EHR ELECTRIC HEAT RELAY
- ENTH ENTHALPY
- ERV ENERGY RECOVERY VENTILATOR
- ESL ENTHALPY SENSOR - LOW
- FB FUSE BLOCK
- FIOP FACTORY INSTALLED OPTION
- FPT FREEZE PROTECTION THERMOSTAT
- FST FAN HOUSING TEMP SENSOR
- FU FUSE
- G THERMOSTAT FAN CALL
- GR(ND) GROUND
- HACR HEATING, AIR-CONDITIONING, REFRIGERATION BREAKER
- HR HEATER RELAY
- HGRH HOT GAS REHEAT
- HPC HEAD PRESSURE CONTROL
- HPS HIGH PRESSURE SWITCH
- IAQ INDOOR AIR QUALITY SENSORS
- IFM INDOOR FAN MOTOR
- IFMC INDOOR FAN MOTOR CONTROL
- IFO INDOOR FAN ON SIGNAL
- IRH INDOOR RELATIVE HUMIDITY
- JMP JUMPER
- L1 LINE 1
- LA LOW AMBIENT LOCKOUT
- LAR LOW AMBIENT RELAY
- LAS LOW AMBIENT SWITCH
- LDR COMPRESSOR LOADER
- LEN LOCAL EQUIPMENT NETWORK
- LLSVR LIQUID LINE SOLENOID VALVE
- LOC LOSS OF CHARGE
- LPS LOW PRESSURE SWITCH
- LS LIMIT SWITCH
- LSM LIMIT SWITCH (MANUAL RESET)
- LTLO LOW TEMP LOCKOUT

- MTR MOTOR
- OAO OUTDOOR AIR QUALITY
- OAT OUTDOOR AIR TEMP. SEN
- OFM OUTDOOR FAN MOTOR
- OFR OUTDOOR FAN RELAY
- OL OVERLOAD
- PER POWER EXHAUST RELAY
- PH PHASE
- PL PLUG ASSEMBLY
- POT POTENTIOMETER
- PMR PHASE MONITOR RELAY
- PS PRESSURE SWITCH
- PWM PULSE WIDTH MODULATION
- PTM QUADRUPLE TERMINAL
- R THERMOSTAT POWER
- RAT RETURN AIR TEMP. SENOR
- RLV REHEAT LIQUID VALVE
- RNET LOCAL ACCESS NETWORK
- RVS REVERSING VALVE SOLENOID
- SAT SUPPLY AIR TEMP SENSOR
- SDP SYSTEM DISCHARGE PRESSURE
- SPT SPACE TEMPERATURE PRESSURE
- SSTO SPACE TEMPERATURE OFFSET
- SSP SYSTEM SUCTION PRESSURE
- SW SWITCH
- TB TERMINAL BLOCK
- TDR TIME DELAY RELAY
- TRAN TRANSFORMER
- UCB UNIT CONTROL BOARD
- W1 1st STAGE OF HEATING CALL
- W2 2nd STAGE OF HEATING CALL
- Y1 1st STAGE OF COOLING CALL
- Y2 2nd STAGE OF COOLING CALL

48TC003156 D

Typical 50GCQ*04-06 Power Wiring Diagram, 460/575-3-60 Unit Shown

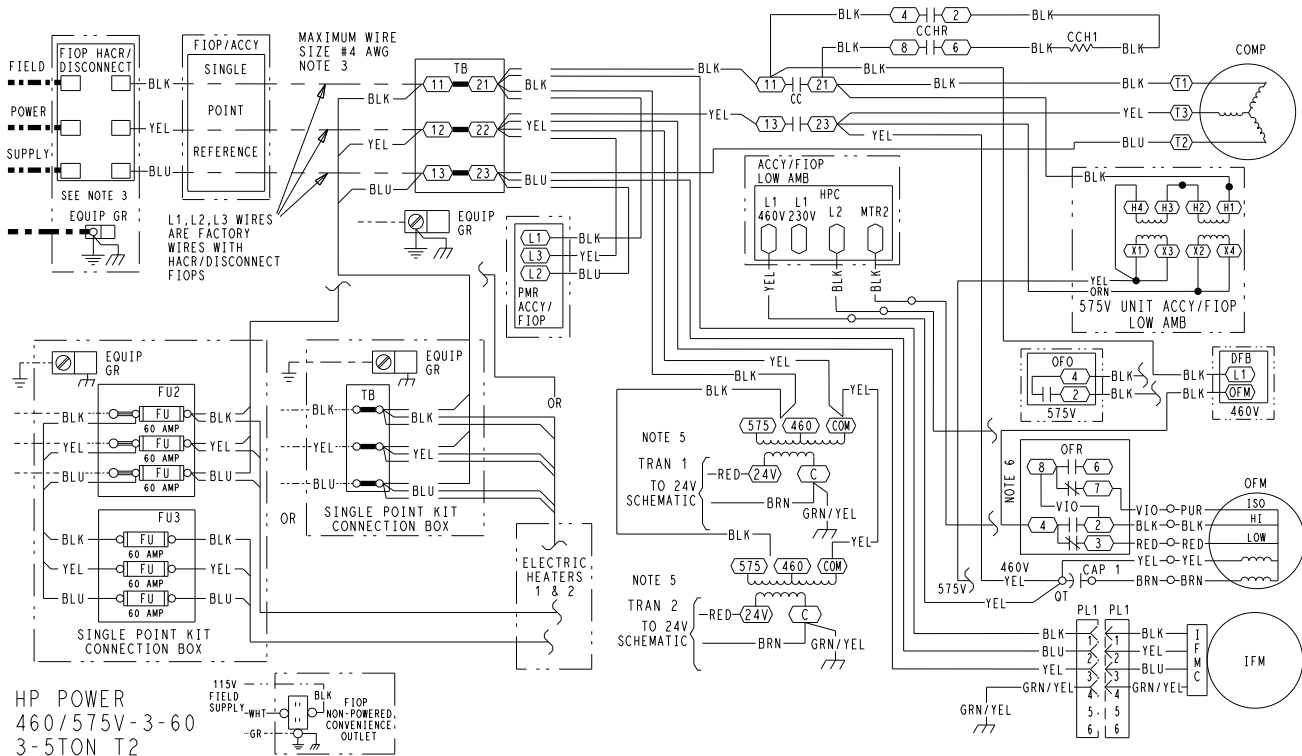

HP POWER
460/575V-3-60
3-5TON T2

NOTES

- IF ANY OF THE ORIGINAL WIRE FURNISHED MUST BE REPLACED. IT MUST BE REPLACED WITH TYPE 90° C WIRE OR ITS EQUIVALENT.
- COMPRESSOR AND FAN MOTORS ARE THERMALLY PROTECTED.
- USE COPPER CONDUCTOR ONLY.
- DO NOT DISCONNECT POWER-PLUG OR SIGNAL WIRE WHILE UNDER LOAD.
- TRANSFORMER IS DEDICATED BASED ON UNIT VOLTAGE. TAPS ONLY SHOWN TO SIMPLIFY SCHEMATIC.
- THIS WIRE NOT USED WITH LOW AMBIENT FIOP/ACCY.

LEGEND

- MARKED WIRE
- TERMINAL (MARKED)
- TERMINAL (UNMARKED)
- TERMINAL BLOCK
- SPLICE
- SPLICE (MARKED)
- FACTORY WIRING
- FIELD CONTROL WIRING
- FIELD POWER WIRING
- CIRCUIT BOARD TRACE
- ACCESSORY OR OPTIONAL WIRING

- ACCY ACCESSORY
- AWG AMERICAN WIRE GAGE
- BAS BUILDING AUTOMATION NETWORK
- CC CONTACTOR, COMPRESSOR
- C COMMON
- CAP CAPACITOR
- CB CIRCUIT BREAKER
- CCH CRANKCASE HEATER
- CCHR CRANKCASE HEATER RELAY
- CCHT CRANKCASE HEATER TEMP SWITCH
- CLO COMPRESSOR LOCKOUT
- CLV COOLING LIQUID VALVE
- COFS CONDENSATE OVERFLOW SWITCH
- COM SIGNAL COMMON
- COMP COMPRESSOR MOTOR
- DDC DIRECT DIGITAL CONTROL
- DFB DEFROST BOARD
- DFT DEFROST THERMOSTAT
- EHR ELECTRIC HEAT RELAY
- ENTH ENTHALPY
- ERV ENERGY RECOVERY VENTILATOR
- ESL ENTHALPY SENSOR - LOW
- FB FUSE BLOCK
- FIOP FACTORY INSTALLED OPTION
- FPT FREEZE PROTECTION THERMOSTAT
- FST FAN HOUSING TEMP SENSOR
- FU FUSE
- G THERMOSTAT FAN CALL
- G (GRND) GROUND

SEE NOTE 8

- HACR HEATING, AIR-CONDITIONING, REFRIGERATION BREAKER
- HR HEATER RELAY
- HGRH HOT GAS REHEAT
- HPC HEAD PRESSURE CONTROL
- HPS HIGH PRESSURE SWITCH
- HUM HUMIDISTAT
- IAQ INDOOR AIR QUALITY SENSORS
- IFM INDOOR FAN MOTOR
- IFMC INDOOR FAN MOTOR CONTROL
- IFO INDOOR FAN ON SIGNAL
- IRRH INDOOR RELATIVE HUMIDITY
- JMP JUMPER
- L1 LINE 1
- LA LOW AMBIENT LOCKOUT
- LAR LOW AMBIENT RELAY
- LAS LOW AMBIENT SWITCH
- LDR COMPRESSOR LOADER
- LEN LOCAL EQUIPMENT NETWORK
- LOC LOSS OF CHARGE
- LPS LOW PRESSURE SWITCH
- LS LIMIT SWITCH
- LSM LIMIT SWITCH (MANUAL RESET)
- LTLW LOW TEMP LOCKOUT
- MTR MOTOR
- OAO OUTDOOR AIR QUALITY
- OAT OUTDOOR AIR TEMP. SEN
- OFM OUTDOOR FAN MOTOR
- OFO OUTDOOR FAN ON RELAY
- OFR OUTDOOR FAN RELAY
- OL OVERLOAD

- PER POWER EXHAUST RELAY
- PH PHASE
- PL PLUG ASSEMBLY
- POT POTENTIOMETER
- PMR PHASE MONITOR RELAY
- PS PRESSURE SWITCH
- PWM PULSE WIDTH MODULATION
- QT QUADRUPLE TERMINAL
- R THERMOSTAT POWER
- RAT RETURN AIR TEMP. SEN
- RDV REHEAT DISCHARGE VALVE
- RH RELATIVE HUMIDITY
- RLV REHEAT LIQUID VALVE
- RNET LOCAL ACCESS NETWORK
- RVS REVERSING VALVE SOLENOID
- SAT SUPPLY AIR TEMP SENSOR
- SOP SYSTEM DISCHARGE PRESSURE
- SPRH SPACE RELATIVE HUMIDITY
- SPT SPACE TEMPERATURE SENSOR
- SPTO SPACE TEMPERATURE OFFSET
- SSP SYSTEM SUCTION PRESSURE SWITCH
- TB TERMINAL BLOCK
- TDR TIME DELAY RELAY
- TRAN TRANSFORMER
- UCB UNIT CONTROL BOARD
- W1 1st STAGE OF HEATING CALL
- W2 2nd STAGE OF HEATING CALL
- Y1 1st STAGE OF COOLING CALL
- Y2 2nd STAGE OF COOLING CALL

48TC003158 E

Typical 50GCQ*04-06 Power Wiring Diagram, 208/230-1-60 Unit with SystemVu Controller Shown

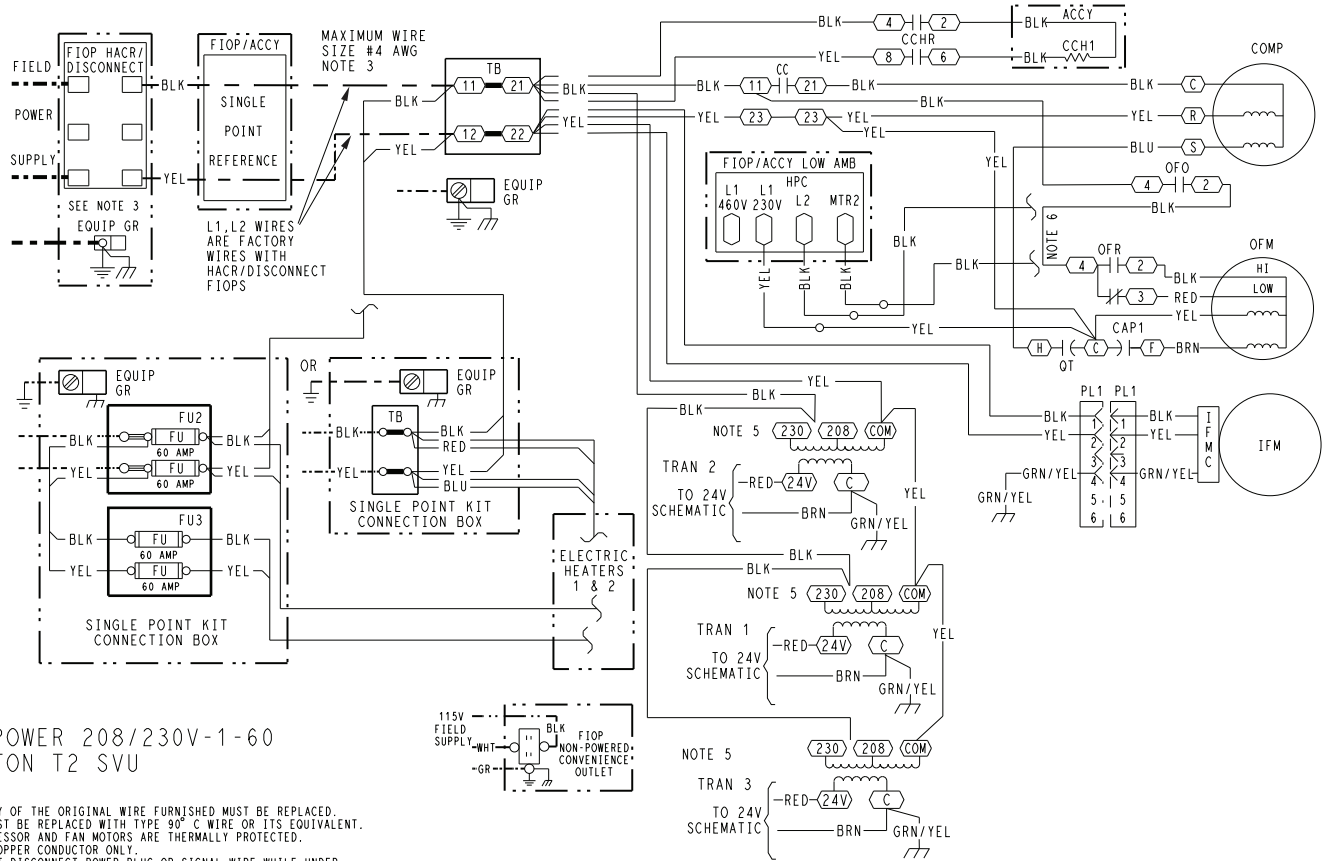

HP POWER 208/230V-1-60
3-5TON T2 SVU

- NOTES**
- IF ANY OF THE ORIGINAL WIRE FURNISHED MUST BE REPLACED, IT MUST BE REPLACED WITH TYPE 90° C WIRE OR ITS EQUIVALENT.
 - COMPRESSOR AND FAN MOTORS ARE THERMALLY PROTECTED.
 - USE COPPER CONDUCTOR ONLY.
 - DO NOT DISCONNECT POWER PLUG OR SIGNAL WIRE WHILE UNDER LOAD.
 - ON 208/230V UNITS, TRAN IS WIRED FOR 230V. IF UNIT IS TO BE RUN WITH 208V POWER SUPPLY, DISCONNECT BLK WIRE FROM 230V TAP AND CONNECT TO 208V TAP.
 - THIS WIRE NOT USED WITH LOW AMBIENT FIOP/ACCY.

LEGEND

- MARKED WIRE
- TERMINAL (MARKED)
- TERMINAL (UNMARKED)
- TERMINAL BLOCK
- SPLICE
- SPLICE (MARKED)
- FACTORY WIRING
- FIELD CONTROL WIRING
- FIELD POWER WIRING
- CIRCUIT BOARD TRACE
- ACCESSORY OR OPTIONAL WIRING

- ACCY ACCESSORY
- AWG AMERICAN WIRE GAGE
- BAS BUILDING AUTOMATION NETWORK
- CC CONTACTOR, COMPRESSOR
- C COMMON
- CAP CAPACITOR
- CB CIRCUIT BREAKER
- CCH CRANKCASE HEATER
- CCHR CRANKCASE HEATER RELAY
- CCHTS CRANKCASE HEATER TEMP SWITCH
- CLO COMPRESSOR LOCKOUT
- CLV COOLING LIQUID VALVE
- COFS CONDENSATE OVERFLOW SWITCH
- COM SIGNAL COMMON
- COMP COMPRESSOR MOTOR
- DDC DIRECT DIGITAL CONTROL
- DFB DEFROST BOARD
- DFT DEFROST THERMOSTAT
- EHR ELECTRIC HEAT RELAY
- ENTH ENTHALPY
- ERV ENERGY RECOVERY VENTILATOR
- ESL ENTHALPY SENSOR - LOW
- FB FUSE BLOCK
- FIOP FACTORY INSTALLED OPTION
- FPT FREEZE PROTECTION THERMOSTAT
- FST FAN HOUSING TEMP SENSOR
- FU FUSE
- G THERMOSTAT FAN CALL
- GR(GND) GROUND
- HACR HEATING, AIR-CONDITIONING, REFRIGERATION BREAKER

- HR HEATER RELAY
- HGRH HOT GAS REHEAT
- HPC HEAD PRESSURE CONTROL
- HPS HIGH PRESSURE SWITCH
- HUM HUMIDISTAT
- IAQ INDOOR AIR QUALITY SENSORS
- IFM INDOOR FAN MOTOR
- IFMC INDOOR FAN MOTOR CONTROL
- IFO INDOOR FAN ON SIGNAL
- IRH INDOOR RELATIVE HUMIDITY
- JMP JUMPER
- L1 LINE 1
- LA LOW AMBIENT LOCKOUT
- LAR LOW AMBIENT RELAY
- LAS LOW AMBIENT SWITCH
- LDR COMPRESSOR LOADER
- LEN LOCAL EQUIPMENT NETWORK
- LOC LOSS OF CHARGE
- LPS LOW PRESSURE SWITCH
- LS LIMIT SWITCH
- LSM LIMIT SWITCH (MANUAL RESET)
- LTLO LOW TEMP LOCKOUT
- MTR MOTOR
- OAQ OUTDOOR AIR QUALITY
- OAT OUTDOOR AIR TEMP. SEN
- OFM OUTDOOR FAN MOTOR
- OFO OUTDOOR FAN ON RELAY
- OFR OUTDOOR FAN RELAY
- OL OVERLOAD

- PER POWER EXHAUST RELAY
- PH PHASE
- PL PLUG ASSEMBLY
- POT POTENTIOMETER
- PMR PHASE MONITOR RELAY
- PS PRESSURE SWITCH
- PWM PULSE WIDTH MODULATION
- QT QUADRUPLE TERMINAL
- R THERMOSTAT POWER
- RAT RETURN AIR TEMP. SEN
- RDV REHEAT DISCHARGE VALVE
- RH REHEAT HUMIDITY
- RLV REHEAT LIQUID VALVE
- RNET LOCAL ACCESS NETWORK
- RVS REVERSING VALVE SOLENOID
- SAT SUPPLY AIR TEMP. SENSOR
- SDP SYSTEM DISCHARGE PRESSURE
- SPRH SPACE RELATIVE HUMIDITY
- SPT SPACE TEMPERATURE SENSOR
- SPTO SPACE TEMPERATURE OFFSET
- SSP SYSTEM SUCTION PRESSURE SWITCH
- SW SWITCH
- TB TERMINAL BLOCK
- TDR TIME DELAY RELAY
- TRAN TRANSFORMER
- UCB UNIT CONTROL BOARD
- W1 1st STAGE OF HEATING CALL
- W2 2nd STAGE OF HEATING CALL
- Y1 1st STAGE OF COOLING CALL
- Y2 2nd STAGE OF COOLING CALL

48TC003208 A

Typical wiring diagrams (cont)

Typical 50GCQ*04-06 Power Wiring Diagram, 208/230-3-60 Unit with SystemVu Controller Shown

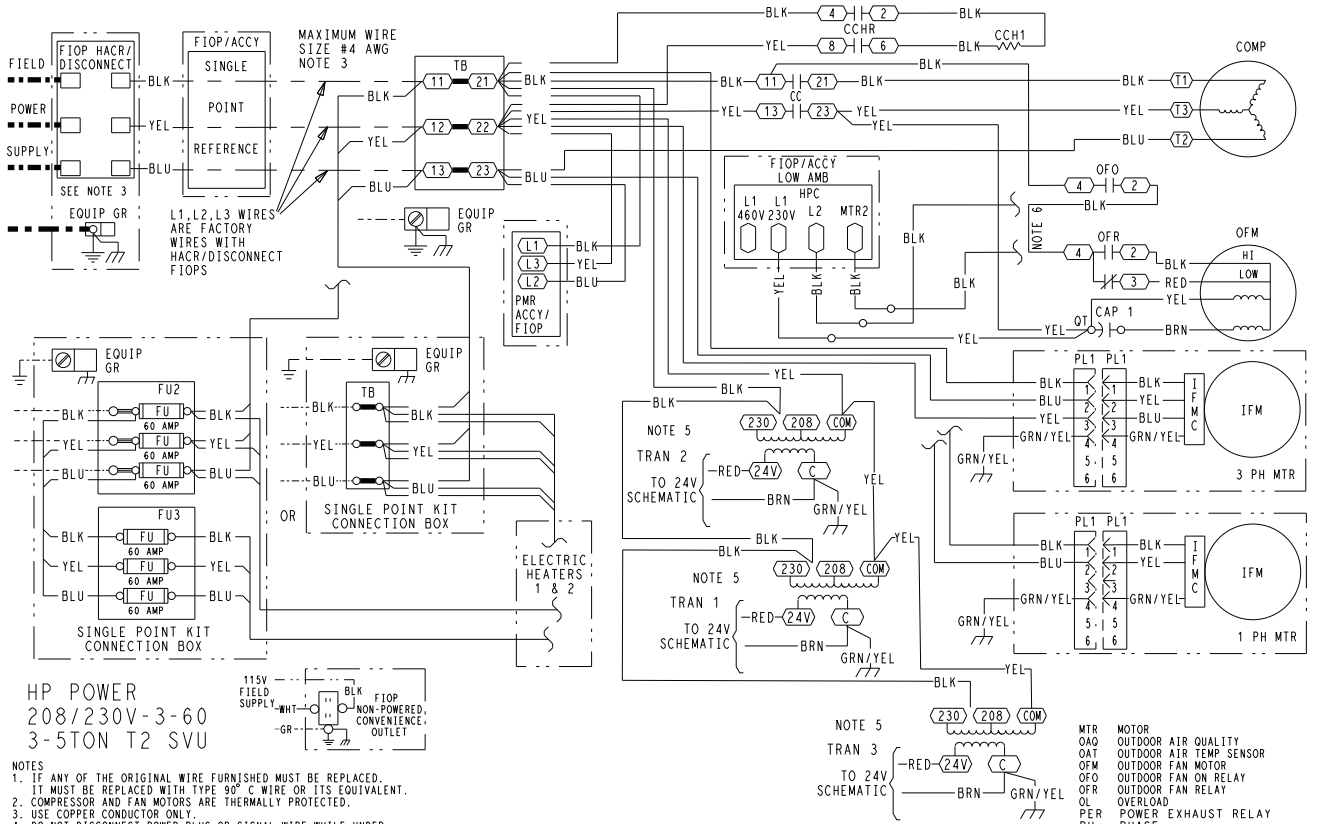

HP POWER
208/230V-3-60
3-5TON T2 SVU

- NOTES**
- IF ANY OF THE ORIGINAL WIRE FURNISHED MUST BE REPLACED, IT MUST BE REPLACED WITH TYPE 90° C WIRE OR ITS EQUIVALENT.
 - COMPRESSOR AND FAN MOTORS ARE THERMALLY PROTECTED.
 - USE COPPER CONDUCTOR ONLY.
 - DO NOT DISCONNECT POWER PLUG OR SIGNAL WIRE WHILE UNDER LOAD.
 - ON 208/230V UNITS, TRAN IS WIRED FOR 230V. IF UNIT IS TO BE RUN WITH 208V POWER SUPPLY, DISCONNECT BLK WIRE FROM 230V TAP AND CONNECT TO 208V TAP.
 - THIS WIRE NOT USED WITH LOW AMBIENT FIOp/ACCY.

LEGEND

- MARKED WIRE
- TERMINAL (MARKED)
- TERMINAL (UNMARKED)
- TERMINAL BLOCK
- SPLICE
- SPLICE (MARKED)
- FACTORY WIRING
- FIELD CONTROL WIRING
- FIELD POWER WIRING
- CIRCUIT BOARD TRACE
- ACCESSORY OR OPTIONAL WIRING

- ACCY ACCESSORY
- AWG AMERICAN WIRE GAGE
- BAS BUILDING AUTOMATION NETWORK
- CC CONTACTOR, COMPRESSOR
- COM COMMON
- CAP CAPACITOR
- CB CIRCUIT BREAKER
- CCH CRANKCASE HEATER
- CCHR CRANKCASE HEATER RELAY
- CCHTS CRANKCASE HEATER TEMP SWITCH
- CLO COMPRESSOR LOCKOUT
- CLV COOLING LIQUID VALVE
- COFS CONDENSATE OVERFLOW SWITCH
- COM SIGNAL COMMON
- COMP COMPRESSOR MOTOR
- DCD DIRECT DIGITAL CONTROL
- DFB DEFROST BOARD
- DFT DEFROST THERMOSTAT
- ENR ELECTRIC HEAT RELAY
- ENTH ENTHALPY
- ERV ENERGY RECOVERY VENTILATOR
- ESL ENTHALPY SENSOR - LOW
- FB FUSE BLOCK
- FIOp FACTORY INSTALLED OPTION
- FPT FREEZE PROTECTION THERMOSTAT
- FST FAN HOUSING TEMP SENSOR
- FU FUSE
- G THERMOSTAT FAN CALL
- GR(IND) GROUND
- HACR HEATING, AIR-CONDITIONING, REFRIGERATION BREAKER
- HR HEATER RELAY
- HGRH HOT GAS REHEAT
- HPC HEAD PRESSURE CONTROL
- HPS HIGH PRESSURE SWITCH
- HUM HUMIDISTAT
- IQA INDOOR AIR QUALITY SENSORS
- IFM INDOOR FAN MOTOR
- IFMC INDOOR FAN MOTOR CONTROL
- IFO INDOOR FAN ON SIGNAL
- IRH INDOOR RELATIVE HUMIDITY
- JMP JUMPER
- L1 LINE 1
- LA LOW AMBIENT LOCKOUT
- LAR LOW AMBIENT RELAY
- LAS LOW AMBIENT SWITCH
- LDR COMPRESSOR LOADER
- LEN LOCAL EQUIPMENT NETWORK
- LOC LOSS OF CHARGE
- LPS LOW PRESSURE SWITCH
- LS LIMIT SWITCH
- LSM LIMIT SWITCH (MANUAL RESET)
- LTLO LOW TEMP LOCKOUT
- MTR MOTOR
- OAO OUTDOOR AIR QUALITY SENSOR
- OAT OUTDOOR AIR TEMP SENSOR
- OFM OUTDOOR FAN MOTOR
- OFO OUTDOOR FAN ON RELAY
- OFN OUTDOOR FAN RELAY
- OL OVERLOAD
- PER POWER EXHAUST RELAY
- PH PHASE
- PL PLUG ASSEMBLY
- POT POTENTIOMETER
- PMR PHASE MONITOR RELAY
- PS PRESSURE SWITCH
- PWM PULSE WIDTH MODULATION
- QT QUADRUPLE TERMINAL
- R THERMOSTAT POWER
- RAT RETURN AIR TEMP SENSOR
- RDV REHEAT DISCHARGE VALVE
- RH RELATIVE HUMIDITY
- RLV REHEAT LIQUID VALVE
- RNET LOCAL ACCESS NETWORK
- RVS REVERSING VALVE SOLENOID
- SAT SUPPLY AIR TEMP SENSOR
- SDP SYSTEM DISCHARGE PRESSURE
- SPRH SPACE RELATIVE HUMIDITY
- SPT SPACE TEMPERATURE SENSOR
- SPTO SPACE TEMPERATURE OFFSET
- SSP SYSTEM SUCTION PRESSURE SWITCH
- SW SWITCH
- TB TERMINAL BLOCK
- TDR TIME DELAY RELAY
- TRAN TRANSFORMER
- UCB UNIT CONTROL BOARD
- W1 1st STAGE OF HEATING CALL
- W2 2nd STAGE OF HEATING CALL
- Y1 1st STAGE OF COOLING CALL
- Y2 2nd STAGE OF COOLING CALL

48TC003209 D

Typical 50GCQ*04-06 Power Wiring Diagram, 460/575-3-60 Unit with SystemVu Controller Shown

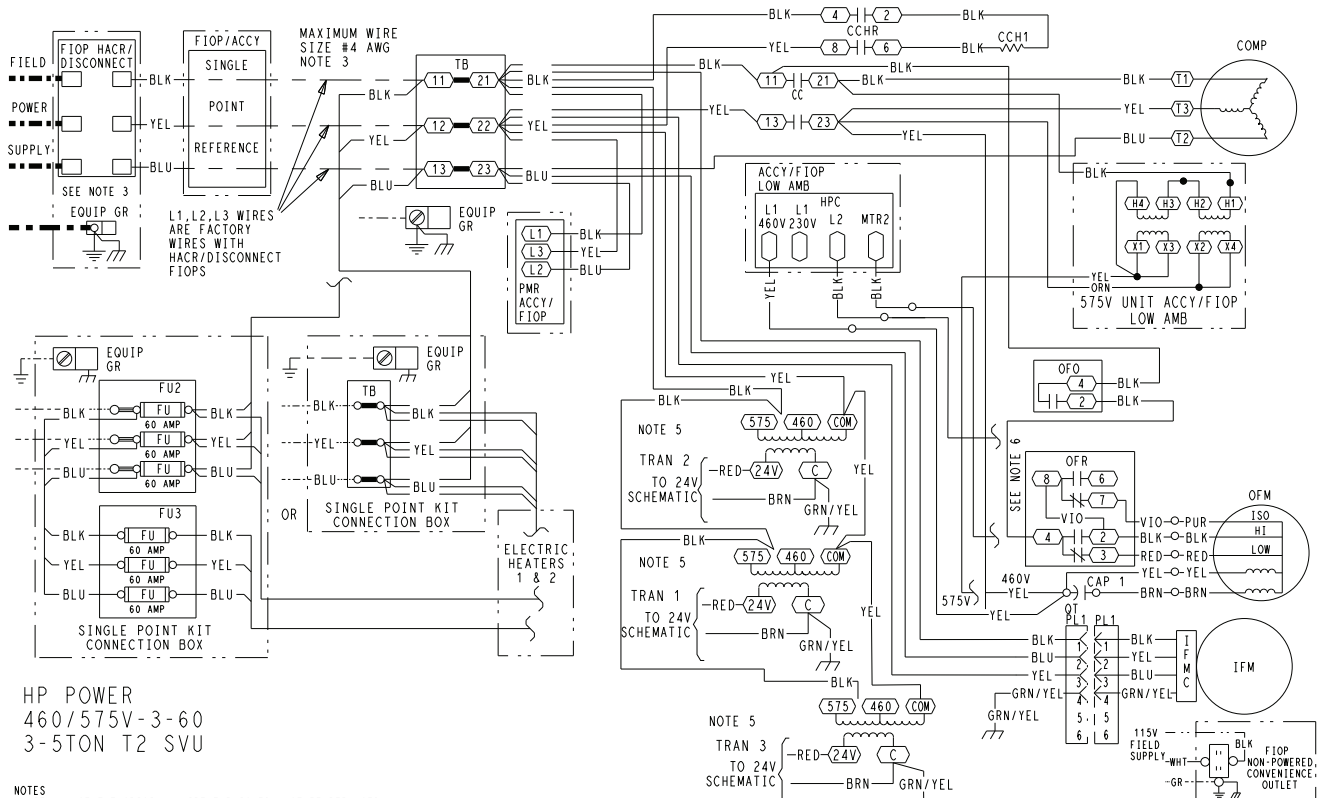

HP POWER
460/575V-3-60
3-5TON T2 SVU

NOTES

1. IF ANY OF THE ORIGINAL WIRE FURNISHED MUST BE REPLACED, IT MUST BE REPLACED WITH TYPE 90° C WIRE OR ITS EQUIVALENT.
2. COMPRESSOR AND FAN MOTORS ARE THERMALLY PROTECTED.
3. USE COPPER CONDUCTOR ONLY.
4. DO NOT DISCONNECT POWER PLUG OR SIGNAL WIRE WHILE UNDER LOAD.
5. TRANSFORMER IS DEDICATED BASED ON UNIT VOLTAGE. TAPS ONLY SHOWN TO SIMPLIFY SCHEMATIC.
6. THIS WIRE NOT USED WITH LOW AMBIENT FIOP/ACCY.

LEGEND

- MARKED WIRE
- TERMINAL (UNMARKED)
- TERMINAL BLOCK
- SPLICE
- SPLICE (MARKED)
- FACTORY WIRING
- FIELD CONTROL WIRING
- FIELD POWER WIRING
- CIRCUIT BOARD TRACE
- ACCESSORY OR OPTIONAL WIRING

- ACCY ACCESSORY
- AWG AMERICAN WIRE GAGE
- BAS BUILDING AUTOMATION NETWORK
- CC CONTACTOR, COMPRESSOR
- C COMMON
- CAP CAPACITOR
- CB CIRCUIT BREAKER
- CCH CRANKCASE HEATER
- CCHR CRANKCASE HEATER RELAY
- CCHTS CRANKCASE HEATER TEMP SWITCH
- CLO COMPRESSOR LOCKOUT
- CLV COOLING LIQUID VALVE
- COFS CONDENSATE OVERFLOW SWITCH
- COM SIGNAL COMMON
- COMP COMPRESSOR MOTOR
- DDC DIRECT DIGITAL CONTROL
- DFB DEFROST BOARD
- DFT DEFROST THERMOSTAT
- EHR ELECTRIC HEAT RELAY
- ENTH ENTHALPY
- ERV ENERGY RECOVERY VENTILATOR
- ESL ENTHALPY SENSOR - LOW
- FB FUSE BLOCK
- FIOP FACTORY INSTALLED OPTION
- FPT FREEZE PROTECTION THERMOSTAT
- FST FAN HOUSING TEMP SENSOR
- FU FUSE
- G THERMOSTAT FAN CALL
- GR(ND) GROUND
- HACR HEATING, AIR-CONDITIONING, REFRIGERATION BREAKER
- HR HEATER RELAY
- HGRH HOT GAS REHEAT
- HPC HEAD PRESSURE CONTROL
- HPS HIGH PRESSURE SWITCH
- HUM HUMIDISTAT
- IAQ INDOOR AIR QUALITY SENSORS
- IFM INDOOR FAN MOTOR
- IFMC INDOOR FAN MOTOR CONTROL
- IFO INDOOR FAN ON SIGNAL
- IRH INDOOR RELATIVE HUMIDITY
- JMP JUMPER
- L1 LINE 1
- LA LOW AMBIENT LOCKOUT
- LAR LOW AMBIENT RELAY
- LAS LOW AMBIENT SWITCH
- LDR COMPRESSOR LOADER
- LEN LOCAL EQUIPMENT NETWORK
- LOC LOSS OF CHARGE
- LPS LOW PRESSURE SWITCH
- LS LIMIT SWITCH
- LSM LIMIT SWITCH (MANUAL RESET)
- LTL LOW TEMP LOCKOUT
- MTR MOTOR
- OAQ OUTDOOR AIR QUALITY
- OAT OUTDOOR AIR TEMP. SEN
- OFM OUTDOOR FAN MOTOR
- OFR OUTDOOR FAN RELAY
- OFO OUTDOOR FAN ON RELAY
- OL OVERLOAD

- PER POWER EXHAUST RELAY
- PH PHASE
- PL PLUG ASSEMBLY
- POT POTENTIOMETER
- PMR PHASE MONITOR RELAY
- PS PRESSURE SWITCH
- PWM PULSE WIDTH MODULATION
- QT QUADRUPLE TERMINAL
- R THERMOSTAT POWER
- RAT RETURN AIR TEMP. SEN
- RDV REHEAT DISCHARGE VALVE
- RH RELATIVE HUMIDITY
- RLV REHEAT LIQUID VALVE
- RNET LOCAL ACCESS NETWORK
- RVS REVERSING VALVE SOLENOID
- SAT SUPPLY AIR TEMP SENSOR
- SDP SYSTEM DISCHARGE PRESSURE
- SPRH SPACE RELATIVE HUMIDITY
- SPT SPACE TEMPERATURE SENSOR
- SPTO SPACE TEMPERATURE OFFSET
- SSP SYSTEM SUCTION PRESSURE
- SW SWITCH
- TB TERMINAL BLOCK
- TDR TIME DELAY RELAY
- TRAN TRANSFORMER
- UCB UNIT CONTROL BOARD
- W1 1st STAGE OF HEATING CALL
- W2 2nd STAGE OF HEATING CALL
- Y1 1st STAGE OF COOLING CALL
- Y2 2nd STAGE OF COOLING CALL

48TC003210 E

General

The sequence below describes the sequence of operation for an electromechanical unit with and without a factory-installed EconomizerONE (POL224 controller; called “economizer” in this sequence). For information regarding a direct digital controller, see the start-up, operations, and troubleshooting manual for the applicable controller.

Electromechanical units without economizer

Cooling (two stage units)

When the thermostat calls for cooling, terminals G and Y1 are energized. The indoor fan will run at the low fan speed and the compressor contactor (CC) is energized causing the compressor and outdoor fan to turn on. The low indoor fan speed is 75% of the user set fan speed, the compressor will run at partial capacity, and the outdoor fan will run at low speed.

If additional cooling is needed, the thermostat will add the call for Y2. This will increase the indoor fan speed to the user set fan speed, energize the compressor loader for full compressor capacity, and energize the outdoor fan relay (OFR) for high speed.

When the thermostat removes the call for Y2 but leaves the Y1, the indoor fan will reduce speed to 75% of the user set fan speed, the compressor loader will turn off, and the outdoor fan will drop to low speed. When the thermostat removes the call for Y1 the compressor contactor will de-energize, shutting down the compressor and the outdoor fan. When the thermostat removes the call for G, the indoor fan will turn off after the specific unit fan off delay.

Heating, unit with economizer

Upon a request for heating from the space thermostat terminal, W1 will be energized with 24V. The indoor fan contactor (IFC), outdoor fan contactor (OFC), as well as C1 and C2 will be energized in heating. The indoor fan, outdoor fans, and both stages of the compressor are energized. The reversing valves are energized and switch positions. The economizer is set to minimum position (ventilation position).

If the space temperature continues to fall with W1 energized, W2 will bring on all electric heat (HC).

As the space temperature rises the W2 will de-energize and the compressors will continue to operate, until the thermostat set point is achieved de-energizing W1.

If the thermostat is set to Auto, the indoor fan will de-energize and the economizer will close.

If the indoor fan is set to On, the indoor fan will continue to operate and the economizer will remain at minimum position (vent position).

On units equipped for 2 stages of heat, when additional heat is needed, heater contactor no. 2 is energized through W2. The economizer damper moves to the minimum position.

When the thermostat is satisfied, the damper moves to the fully closed position.

Heating, unit without economizer

Upon a request for heating from the space thermostat, terminal W1 will be energized with 24V. The IFC, outdoor fan contactor (OFC), as well as C1 and C2 will be energized. The indoor fan, outdoor fans, compressor no. 1 and compressor no. 2 are energized. The reversing valves are de-energized and switch position.

If the space temperature continues to fall while W1 is energized, W2 will be energized with 24V, and the heater contactor(s) (HC) will be energized, which will energize the electric heater(s).

When the space thermostat is satisfied, W2 will be de-energized first, and the electric heater(s) will also be de-energized. Upon a further rise in space temperature, W1 will be de-energized.

Electric heating

NOTE: Base 50GCQ units are cooling and heat pump heating only. If supplement electric heaters are required, use only factory-approved heaters listed and offered by Carrier.

Units have either 1 or 2 stages of electric heat. When the thermostat calls for heating, power is applied to G and the W1 terminals at the unit. The unit control will energize the indoor fan contactor and the first stage of electric heat. On units with two-stage heating, when additional heating is required, the second stage of electric heat (if equipped) will be energized when power is applied at the W2 terminal on the unit.

IMPORTANT: The thermostat must be configured for Electric Heat so it will energize G with the W1 call.

Electromechanical units with EconomizerONE

Cooling

NOTE: EconomizerONE is available as both a factory-installed option or a field-installed accessory.

When free cooling is not available, the compressors will be controlled by the zone thermostat. When free cooling is available, the outdoor-air damper is modulated by the EconomizerONE control to provide a 50°F (10°C) to 55°F (13°C) mixed-air temperature into the zone. As the mixed air temperature fluctuates above 55°F (13°C) or below 50°F (10°C) dampers will be modulated (open or close) to bring the mixed-air temperature back within control. If mechanical cooling is utilized with free cooling, the outdoor-air damper will maintain its current position at the time the compressor is started. If the increase in cooling capacity causes the mixed-air temperature to drop below 45°F (7°C), then the outdoor-air damper position will be decreased to the minimum position. If the mixed-air temperature continues to fall, the outdoor-air damper will close. Control returns to normal once the mixed-air temperature rises above 48°F (9°C). The power exhaust fans will be energized and de-energized, if installed, as the outdoor-air damper opens and closes.

If field-installed accessory CO₂ sensors are connected to the EconomizerONE control, a demand controlled ventilation strategy will begin to operate. As the CO₂ level in the zone increases above the CO₂ set point (on the EconomizerONE controller), the minimum position of the damper will be increased proportionally until the Maximum Ventilation setting is reached. As the CO₂ level decreases because of the increase in fresh air, the outdoor-air damper will follow the higher demand condition from either the DVC mode or from the free cooling mode. For EconomizerONE operation, there must be a thermostat call for the fan (G). If the unit is occupied and the fan is on, the damper will operate at minimum position. Otherwise, the damper will be closed.

When the EconomizerONE control is in the occupied mode and a call for cooling exists (Y1 on the thermostat), the control will first check for indoor fan operation. If the fan is not on, then cooling will not be activated. If the fan is on, then the control will open the EconomizerONE damper to the minimum position.

On the initial power to the EconomizerONE control, it will take the damper up to 2-1/2 minutes before it begins to position itself. After the initial power-up, further changes in damper position can take up to 90 seconds to initiate. Damper movement from full closed to full open (or vice versa) will take between 1-1/2 and 2-1/2 minutes. If free cooling can be used as determined from the appropriate changeover command (dry bulb, outdoor enthalpy, differential dry bulb, or differential enthalpy), then the control will modulate the dampers open and closed to maintain the mixed-air temperature set-point at 50°F (10°C) to 55°F (13°C). If there is a further demand for cooling (cooling second stage — Y2 is energized), then the control will bring on compressor stage 1 to maintain the mixed-air temperature set-point. The EconomizerONE damper will be open at maximum position.

Two-Speed Note: When operating in ventilation mode only, the indoor fan motor will automatically adjust to 75% of the total cfm established.

Defrost

When the temperature of the outdoor coil drops below 28°F (-2°C) as sensed by the defrost thermostat (DFT2) and the defrost timer is at the end of a timed period (adjustable at 30, 60, 90 or 120 minutes), reversing valve solenoids (RVS1 and RVS2) are energized and the OFC is de-energized. This switches the position of the reversing valves and shuts off the outdoor fan. The electric heaters (if installed) will be energized.

RTU Open controller (factory option)

For details on operating 50GCQ units equipped with the factory-installed RTU Open controller option, refer to Factory Installed RTU Open Multi-Protocol Controller Controls, Start-Up, Operation and Troubleshooting manual.

SystemVu™ controller (factory option)

For details on operating 50GCQ units equipped with the factory-installed SystemVu controller option, refer to FCQ/GCQ Series Single Package Rooftop Units with SystemVu Controller Controls, Start-Up, Operation and Troubleshooting manual.

Minimum operating ambient temperature (cooling)

In mechanical cooling mode, your Carrier rooftop unit can safely operate down to an outdoor ambient temperature of 35°F (2°C). It is possible to provide cooling at lower outdoor ambient temperatures by using less outside air, economizers, and/or accessory low ambient kits.

Maximum operating ambient temperature (cooling)

The maximum operating ambient temperature for cooling mode is 125°F (52°C) at nominal voltage rating. While cooling operation above 125°F (52°C) may be possible, it could cause either a reduction in performance, reliability, or a protective action by the unit's internal safety devices.

Multiple motor and drive packages

Some applications need larger horsepower motors, some need more airflow, and some need both. Regardless of the case, your Carrier expert has a factory-installed combination to meet your application. A wide selection of motors and pulleys (drives) are available, factory installed, to handle nearly any application.

Minimum and maximum airflow (heating and cooling)

To maintain safe and reliable operation of your rooftop, operate within the heating airflow limits during heating mode and cooling airflow limits during cooling mode. Operating above the max may cause blow-off, undesired airflow noise, or airflow related problems with the rooftop unit. Operating below the min may cause problems with coil freeze-up and unsafe heating operation. Heating and cooling limitations differ when evaluating operating cfm, the minimum value is the HIGHER of the cooling and heating minimum cfm values published on page 7 and the maximum value is the LOWER of the cooling and heating minimum values published on page 7.

Heating-to-cooling changeover

Your unit will automatically change from heating to cooling mode when using a thermostat with an auto-changeover feature.

Airflow

All units are draw-through in cooling mode and blow-through in heating mode.

Outdoor air application strategies

Economizers reduce operating expenses and compressor run time by providing a free source of cooling and a means of ventilation to match application changing needs. In fact, they should be considered for most applications. Also,

consider the various economizer control methods and their benefits, as well as sensors required to accomplish your application goals. Please contact your local Carrier representative for assistance.

Motor limits, break horsepower (bhp)

Due to internal design of Carrier units, the air path, and specially designed motors, the full horsepower (maximum continuous bhp) band, as listed in the Fan Performance tables, can be used with the utmost confidence. There is no need for extra safety factors, as Carrier motors are designed and rigorously tested to use the entire, listed bhp range without either nuisance tripping or premature motor failure.

Sizing a rooftop

Bigger is not necessarily better. While an air conditioner needs to have enough capacity to meet the design loads, it does not need excess capacity. In fact, excess capacity typically results in very poor part load performance and humidity control.

Using higher design temperatures than ASHRAE recommends for your location, adding "safety factors" to the calculated load, are all signs of oversizing air conditioners. Oversizing the air conditioner leads to poor humidity control, reduced efficiency, higher utility bills, larger indoor temperature swings, excessive noise, and increased wear and tear on the air conditioner.

Rather than oversizing an air conditioner, engineers should "right-size" or even slightly "under-size" air conditioners. Correctly sizing an air conditioner controls humidity better; promotes efficiency; reduces utility bills; extends equipment life, and maintains even, comfortable temperatures. Please contact your local Carrier representative for assistance.

Low ambient applications

The optional Carrier economizer can adequately cool your space by bringing in fresh, cool outside air. In fact, when so equipped, accessory low-ambient kit may not be necessary. In low ambient conditions, unless the outdoor air is excessively humid or contaminated, economizer-based "free cooling" is the preferred less costly and energy conscious method. In low ambient applications where outside air might not be desired (such as contaminated or excessively humid outdoor environments), your Carrier rooftop can operate to ambient temperatures down to -20°F (-29°C) using the recommended accessory low ambient controller.

Two stage cooling operation

Use appropriate two stage thermostat to achieve the unit's optimum design comfort and overall operating performance.

Note about this specification:

This specification is in the "Masterformat" as published by the Construction Specification Institute. Please feel free to copy this specification directly into your building spec.



High Efficiency Rooftop Packaged Heat Pump

HVAC Guide Specifications

Size Range: **3 to 5 Nominal Tons**

Carrier Model Number: **50GCQ*04-06**

Part 1 — (23 06 80) Schedules for Decentralized HVAC Equipment

1.01 (23 06 80.13) Decentralized Unitary HVAC Equipment Schedule:

- A. (23 06 80.13.A.) Rooftop Unit (RTU) Schedule:
 - 1. Schedule is per the project specification requirements.

Part 2 — (23 07 16) HVAC Equipment Insulation

2.01 (23 07 16.13) Decentralized, Rooftop Units:

- A. (23 07 16.13.A.) Evaporator Fan Compartment:
 - 1. Interior cabinet surfaces shall be insulated with a minimum 1/2 in. thick, minimum 1-1/2 lb density, flexible fiberglass insulation bonded with a phenolic binder, neoprene coated on the air side.
 - 2. Insulation and adhesive shall meet NFPA 90A requirements for flame spread and smoke generation.
- B. (23 07 16.13.B.) Electric Heat Compartment:
 - 1. Aluminum foil-faced fiberglass insulation shall be used.
 - 2. Insulation and adhesive shall meet NFPA 90A requirements for flame spread and smoke generation.

Part 3 — (23 09 13) Instrumentation and Control Devices for HVAC

3.01 (23 09 13.13) Sensors and Transmitters:

- A. (23 09 13.13.A.) Thermostats:
 - 1. Thermostat must:
 - a. have capability to energize 2 stages of cooling, and 2 different stages of heating. All models have 2-stage cooling capabilities.
 - b. be heat pump design and include capability for occupancy scheduling.

Part 4 — (23 09 23) Direct Digital Control System for HVAC

4.01 (23 09 23.13) Decentralized, Rooftop Units:

- A. (23 09 23.13.A.) SystemVu™ intelligent integrated Direct Digital Control (DDC) shall provide:
 - 1. Integrated unit operation for comfort cooling, heating ventilation as well as all monitoring, recording and reporting capabilities. Controller

shall also provide diagnostics and alarms of abnormal unit operation through the controller. Controller shall have an intuitive user display and be able to be used in a standalone operation or via building automation system (BAS).

- 2. Quick Unit Status LEDs of: Run — meaning all systems are go, ALERT — that indicates there is currently a non-critical issue with the unit, like filters need to be replaced and FAULT — that indicates the unit has a critical issue and will possibly shut down.
- 3. Six large navigation keys for easy access. Navigation keys shall consist of: TEST, BACK, ENTER, and MENU along with UP and DOWN arrows.
- 4. Full back lit user display with 4 line by 30 character text capabilities. Display menu shall be designed to provide guided major menus and sub menus main menus provided below:
 - a. Shutdown Unit
 - b. Run Status
 - c. Settings
 - d. Alerts/Faults
 - e. Service
 - f. Inputs
 - g. Outputs
 - h. USB
- 5. The capability for standalone operation with conventional thermostat/sensor or use with building automation systems (BAS) of Carrier i-Vu®, BACnet™1 and Carrier Comfort Network® (CCN) systems. No special modules or boards are required for these capabilities. Has the capability to work with Equipment Touch™ and System Touch™ devices and ZS Sensors.
- 6. The ability to read refrigerant pressures at display or via BAS network of; Discharge Pressure and Suction Pressure. The need for traditional refrigerant gauges is not required.
- 7. USB Data Port for flash drive interaction. This will allow the transfer of data for uploads, downloads, perform software upgrades, back-up and restore data and file transfer data such as component number of starts and run hours.
- 8. Reverse Rotation Protection of compressors if field three phase wiring is misapplied.
- 9. Provide Service Capabilities of:
 - a. Auto run test
 - b. Manual run test
 - c. Component run hours and starts
 - d. Commissioning reports
 - e. Data logging
 - f. Alarm history

1. Third-party trademarks and logos are the property of their respective owners.

10. Economizer control and diagnostics. Set up economizer operation, receive feedback from actuator. Also meets the most recent California Title 24, ASHRAE 90.1 and IECC Fault Detection and Diagnostic (FDD) requirements.
 11. Unit cooling operation down to 35°F (2°C).
 12. Controller shall have easy access connections around the controller perimeter area and consist of Mate-N-Lok^{®1}, terminal block and RJ style modular jack connections.
 13. 365 day real time clock, 20 holiday schedules along with occupied and unoccupied scheduling.
 14. Auto-Recognition for easy installation and commissioning of devices like economizers, space sensors, etc.
 15. A 5°F (3°C) temperature difference between cooling and heating set points to meet the latest ASHRAE 90.1 Energy Standard.
 16. Contain return air sensor, supply air sensor and outdoor air sensor to help monitor and provide data for the unit comfort operation, diagnostic and alarms.
 17. Use of Carrier's field accessory hand-held Navigator™ display, Equipment Touch and System Touch devices.
 18. Supply Air Tempering control operates the electric heat to maintain a minimum supply air temperature during conditions where very cold outdoor air causes the supply air temperature to fall below the configured Supply Air Tempering Set Point. This occurs during periods where DCV is active and increasing the amount of outdoor air or in cases where the system is operating at very low airflow and the calculated economizer position has increased to maintain a constant ventilation rate.
 19. Demand limiting in SystemVu™ is achieved through set point expansion. The systems heating and cooling set points are expanded in steps or levels. The degree to which the set points may be expanded is defined by the 6 demand level offsets and the 2 commanded demand limit levels.
 20. 3-year limited part warranty.
- B. (23 09 23.13.B.) RTU Open Protocol, Direct Digital Controller:
1. Shall be ASHRAE 62 compliant.
 2. Shall accept 18-30VAC, 50-60 Hz, and consumer 15VA or less power.
 3. Shall have an operating temperature range from -40°F (-40°C) to 130°F (54°C), 10% to 90% RH (non-condensing).
 4. Shall include built-in protocol for BACnet™1 (MS/TP and PTP modes), Modbus^{®1} (RTU and

ASCII), Johnson N2 and LonWorks^{®1}. LonWorks Echelon processor required for all Lon applications shall be contained in separate communication board.

5. Shall allow access of up to 62 network variables (SNVT). Shall be compatible with all open controllers.
6. Baud rate controller shall be selectable using a DIP switch.
7. Shall have an LED display independently showing the status of serial communication, running, errors, power, all digital outputs, and all analog inputs.
8. Shall accept the following inputs: space temperature, set point adjustment, outdoor air temperature, indoor air quality, outdoor air quality, compressor lock-out, fire shutdown, enthalpy switch, and fan status/filter status/humidity/remote occupancy.
9. Shall provide the following outputs: economizer, fan, cooling stage 1, cooling stage 2, heat stage 1, heat stage 2, exhaust, reversing valve/high fan speed.
10. Shall have built-in surge protection circuitry through solid-state polyswitches. Polyswitches shall be used on incoming power and network connections. Polyswitches will return to normal when the "trip" condition clears.
11. Shall have a battery back-up capable of a minimum of 10,000 hours of data and time clock retention during power outages.
12. Shall have built-in support for Carrier technician tool.
13. Shall include an RS-485 protocol communication port, an access port for connection of either a computer or a Carrier technician tool, an RS-485 port for network communication to intelligent space sensors and displays, and a port to connect an optional LonWorks communications card.
14. Software upgrades will be accomplished by either local or remote download. No software upgrades through chip replacements are allowed.

Part 5 — (23 09 33) Electric and Electronic Control System for HVAC

5.01 (23 09 33.13) Decentralized, Rooftop Units:

A. (23 09 33.13.A.) General:

1. Shall be complete with self-contained low-voltage control circuit protected by a resettable circuit breaker on the 24-v transformer side. Transformer shall have 75VA capability. Two per unit.
2. Shall utilize color-coded wiring.
3. Shall include a Unit Control Board to conveniently and safely provide connection points for vital control functions such as: smoke detectors,

1. Third-party trademarks and logos are the property of their respective owners.

phase monitor, economizer, thermostat, DDC control options, and low and high pressure switches. Controller shall also provide an intuitive means to adjust the indoor fan speed through a simple switch and pot adjustment design.

4. Unit shall include a minimum of one 8-pin screw terminal connection board for connection of control wiring.
 5. Shall include integrated defrost system to prevent excessive frost accumulation during heating duty, and shall be controlled as follows:
 - a. Defrost shall be initiated on the basis of time and coil temperature.
 - b. A 30,60,90,120 minute timer shall activate the defrost cycle only if the coil temperature is low enough to indicate a heavy frost condition.
 - c. Defrost cycle shall terminate when defrost thermostat is satisfied and shall have a positive termination time of 10 minutes.
 6. Defrost system shall also include:
 - a. Defrost Cycle Indicator LED.
 - b. Dip switch selectable defrost time between 30, 60, 90 and 120 minutes. Factory set at 30 minutes.
 - c. Molded plug connection to ensure proper connection.
- B. (23 09 33.13.B.) Safeties:
1. Compressor over-temperature, over-current. High internal pressure differential.
 2. Low Pressure Switch.
 - a. Low pressure switch shall use different color wire than the high pressure switch. The purpose is to assist the installer and service technician to correctly wire and or trouble-shoot the rooftop unit.
 3. High Pressure Switch.
 - a. High pressure switch shall use different color wire than the low pressure switch. The purpose is to assist the installer and service technician to correctly wire and or trouble-shoot the rooftop unit.
 4. Automatic reset, motor thermal overload protector.

Part 6 — (23 09 93) Sequence of Operations for HVAC Controls

- 6.01 (23 09 93.13) Decentralized, Rooftop Units:
- A. (23 09 93.13.A.) INSERT SEQUENCE OF OPERATION

Part 7 — (23 40 13) Panel Air Filters

- 7.01 (23 40 13.13) Decentralized, Rooftop Units:
- A. (23 40 13.13.A.) Standard Filter Section:
 1. Shall consist of factory installed, low velocity, disposable 2 in. thick fiberglass filters of commercially available sizes.
 2. Unit shall use only one filter size. Multiple sizes are not acceptable.
 3. Filters shall be accessible through an access panel with “no-tool” removal as described in the unit cabinet section of this specification (23 81 19.13.G).

Part 8 — (23 81 19) Self-Contained Air Conditioners

- 8.01 (23 81 19.13) Small-Capacity Self-Contained Air Conditioners (50GCQ 04-06):
- A. (23 81 19.13.A.) General:
 1. Outdoor, rooftop mounted, electrically controlled, heating and cooling unit utilizing a fully hermetic scroll compressor(s) for cooling duty and optional electric heat for heating duty.
 2. Factory assembled, single-piece heating and cooling rooftop unit. Contained within the unit enclosure shall be all factory wiring, piping, controls, and special features required prior to field start-up.
 3. Unit shall use Puron® (R-410A) refrigerant.
 4. Unit shall be installed in accordance with the manufacturer’s instructions.
 5. Unit must be selected and installed in compliance with local, state, and federal codes.
 - B. (23 81 19.13.B.) Quality Assurance:
 1. Unit meets and exceeds ASHRAE 90.1 minimum efficiency requirements.
 2. Unit shall be rated in accordance with AHRI Standards 210/240.
 3. Unit shall be designed to conform to ASHRAE 15.
 4. Unit shall be UL-tested and certified in accordance with ANSI Z21.47 Standards and UL-listed and certified under Canadian standards as a total package for safety requirements.
 5. Insulation and adhesive shall meet NFPA 90A requirements for flame spread and smoke generation.
 6. Unit casing shall be capable of withstanding 500 hour salt spray exposure per ASTM B117 (scribed specimen).
 7. Unit shall be designed in accordance with ISO 9001, and shall be manufactured in a facility registered by ISO 9001:2015.
 8. Roof curb shall be designed to conform to NRCA Standards.
 9. Unit shall be subjected to a completely automated run test on the assembly line. The data

for each unit will be stored at the factory, and must be available upon request.

10. Unit shall be designed in accordance with UL Standard 1995, including tested to withstand rain.
 11. Unit shall be constructed to prevent intrusion of snow and tested to prevent snow intrusion into the control box up to 40 mph.
 12. Unit shake tested to assurance level 1, ASTM D4169 to ensure shipping reliability.
- C. (23 81 19.13.C.) Delivery, Storage, and Handling:
1. Unit shall be stored and handled per manufacturer's recommendations.
 2. Lifted by crane requires either shipping top panel or spreader bars.
 3. Unit shall only be stored or positioned in the upright position.
- D. (23 81 19.13.D.) Project Conditions:
1. As specified in the contract.
- E. (23 81 19.13.E.) Operating Characteristics:
1. Unit shall be capable of starting and running at 125°F (52°C) ambient outdoor temperature, meeting maximum load criteria of AHRI Standard 210/240 at ±10% voltage.
 2. Compressor with standard controls shall be capable of operation down to 35°F (2°C), ambient outdoor temperatures. Accessory winter start kit is necessary if mechanically cooling at ambient temperatures down to 25°F (-4°C).
 3. Unit shall discharge supply air vertically or horizontally as shown on contract drawings.
 4. Unit shall be factory configured for vertical supply and return configurations.
 5. Unit shall be field convertible from vertical to horizontal airflow on all models. No special kit required.
 6. Unit shall be capable of mixed operation: vertical supply with horizontal return or horizontal supply with vertical return.
- F. (23 81 19.13.F.) Electrical Requirements:
1. Main power supply voltage, phase, and frequency must match those required by the manufacturer.
- G. (23 81 19.13.G.) Unit Cabinet:
1. Unit cabinet shall be constructed of galvanized steel, and shall be bonderized and coated with a pre-painted baked enamel finish on all externally exposed surfaces.
 2. Unit cabinet exterior paint shall be: film thickness, (dry) 0.003 in. minimum, gloss (per ASTM D523, 60°F/16°C): 60, Hardness: H-2H Pencil hardness.
 3. Evaporator fan compartment interior cabinet insulation shall conform to AHRI Standards 210/240 minimum exterior sweat criteria.
- Interior surfaces shall be insulated with a minimum 1/2 in. thick, 1 lb density, flexible fiberglass insulation, neoprene coated on the air side. Aluminum foil-faced fiberglass insulation shall be used in the heat compartment.
4. Base of unit shall have a minimum of four locations for thru-the-base electrical connections (factory-installed or field-installed), standard.
 5. Base Rail:
 - a. Unit shall have base rails on a minimum of 2 sides.
 - b. Holes shall be provided in the base rails for rigging shackles to facilitate maneuvering and overhead rigging.
 - c. Holes shall be provided in the base rail for moving the rooftop by fork truck.
 - d. Base rail shall be a minimum of 16 gauge thickness.
 6. Condensate Pan and Connections:
 - a. Shall be a sloped condensate drain pan made of a corrosion resistant material.
 - b. Shall comply with ASHRAE Standard 62.
 - c. Shall use a 3/4 in. 14 NPT drain connection, possible either through the bottom or side of the drain pan. Connection shall be made per manufacturer's recommendations.
 7. Top Panel:
 - a. Shall be a single piece top panel on all sizes.
 8. Electrical Connections:
 - a. All unit power wiring shall enter unit cabinet at a single, factory prepared, knockout location.
 - b. Thru-the-base capability.
 - 1) Standard unit shall have a thru-the-base electrical location(s) using a raised, embossed portion of the unit basepan.
 - 2) Optional, factory approved, water-tight connection method must be used for thru-the-base electrical connections.
 - 3) No basepan penetration, other than those authorized by the manufacturer, is permitted.
 9. Component Access Panels (standard):
 - a. Cabinet panels shall be easily removable for servicing.
 - b. Unit shall have one factory installed, tool-less, removable, filter access panel.
 - c. Panels covering control box, indoor fan, indoor fan motor, and compressors shall have molded composite handles.
 - d. Handles shall be UV modified, composite. They shall be permanently attached, and recessed into the panel.

- e. Screws on the vertical portion of all removable access panel shall engage into heat resistant, molded composite collars.
 - f. Collars shall be removable and easily replaceable using manufacturer recommended parts.
- H. (23 81 19.13.H.) Coils:
1. Standard Industry-Proven Aluminum Fin-Copper Tube Coils:
 - a. Standard evaporator and condenser coils shall have aluminum lanced plate fins mechanically bonded to seamless internally grooved copper tubes with all joints brazed.
 - b. Evaporator coils shall be leak tested to 150 psig, pressure tested to 450 psig, and qualified to UL 1995 burst test at 1775 psig.
 - c. Condenser coils shall be leak tested to 150 psig, pressure tested to 650 psig, and qualified to UL 1995 burst test at 1980 psig.
 2. Optional Pre-coated Aluminum-Fin Condenser Coils (3-phase models only):
 - a. Shall have a durable epoxy-phenolic coating to provide protection in mildly corrosive coastal environments.
 - b. Coating shall be applied to the aluminum fin stock prior to the fin stamping process to create an inert barrier between the aluminum fin and copper tube.
 - c. Epoxy-phenolic barrier shall minimize galvanic action between dissimilar metals.
 - d. Corrosion durability of fin stock shall be confirmed through testing to be no less than 1000 hours salt spray per ASTM B117-90.
 - e. Corrosion durability of fin stock shall be confirmed through testing to have no visible corrosion after 48 hour immersion in a room temperature solution of 5% salt, 1% acetic acid.
 - f. Fin stock coating shall pass 2000 hours of the following: one week exposure in the prohesion chamber followed by one week of accelerated ultraviolet light testing. Prohesion chamber: the solution shall contain 3.5% sodium chloride and 0.35% ammonium sulfate. The exposure cycle is one hour of salt fog application at ambient followed by one hour drying at 95°F (35°C).
 3. Optional Copper-Fin Evaporator and Condenser Coils (3-phase models only):
 - a. Shall be constructed of copper fins mechanically bonded to copper tubes and copper tube sheets.
 - b. Galvanized steel tube sheets shall not be acceptable.
 - c. A polymer strip shall prevent coil assembly from contacting the sheet metal coil pan to minimize potential for galvanic corrosion between coil and pan.
 4. Optional E-coated Aluminum-Fin Evaporator and Condenser Coils (3-phase models only):
 - a. Shall have a flexible epoxy polymer coating uniformly applied to all coil surface areas without material bridging between fins.
 - b. Coating process shall ensure complete coil encapsulation of tubes, fins and headers.
 - c. Color shall be high gloss black with gloss per ASTM D523-89.
 - d. Uniform dry film thickness from 0.8 to 1.2 mil on all surface areas including fin edges.
 - e. Superior hardness characteristics of 2H per ASTM D3363-92A and cross-hatch adhesion of 4B-5B per ASTM D3359-93.
 - f. Impact resistance shall be up to 160 in. lb (ASTM D2794-93).
 - g. Humidity and water immersion resistance shall be up to minimum 1000 and 250 hours respectively (ASTM D2247-92 and ASTM D870-92).
 - h. Corrosion durability shall be confirmed through testing to be no less than 1000 hours salt spray per ASTM B117-90.
- I. (23 81 19.13.I.) Refrigerant Components:
1. Refrigerant circuit shall include the following control, safety, and maintenance features:
 - a. TXV cooling metering system on all models shall include a multiple feed distribution system. Fixed heating orifice metering system on all 04-06 models shall include a multiple feed distribution system that optimizes coil performance.
 - b. Refrigerant filter drier — Solid core design.
 - c. Service gauge connections on suction and discharge lines.
 - d. Pressure gauge access through a specially designed access port in the top panel of the unit.
 - e. Suction line accumulator to provide protection in all operating modes from cooling, heating and reverse cycle switching.
 2. There shall be gauge line access port in the skin of the rooftop, covered by a black, removable plug.
 - a. The plug shall be easy to remove and replace.
 - b. When the plug is removed, the gauge access port shall enable maintenance personnel to route their pressure gauge lines.
 - c. This gauge access port shall facilitate correct and accurate condenser pressure readings by enabling the reading with the compressor access panel on.

- d. The plug shall be made of a leak proof, UV-resistant, composite material.
- 3. Compressors:
 - a. Unit shall use fully hermetic, heat pump duty two stage scroll compressor on single circuit independent refrigeration circuit.
 - b. Compressor motors shall be cooled by refrigerant gas passing through motor windings.
 - c. Compressors shall be internally protected from high discharge temperature conditions.
 - d. Compressors shall be protected from an over-temperature and over-amperage conditions by an internal, motor overload device.
 - e. Compressor shall be factory mounted on rubber grommets.
 - f. Compressor motors shall have internal line break thermal, current overload and high pressure differential protection.
 - g. Crankcase heaters shall not be required for normal operating range, unless required by compressor manufacturer due to refrigerant charge limits.
- J. (23 81 19.13.J.) Filter Section:
 - 1. Filters access is specified in the unit cabinet section of this specification.
 - 2. Filters shall be held in place by a pivoting filter tray, facilitating easy removal and installation.
 - 3. Shall consist of factory installed, low velocity, throw-away 2 in. thick fiberglass filters.
 - 4. Filters shall be standard, commercially available sizes.
 - 5. Only one size filter per unit is allowed.
- K. (23 81 19.13.K.) Evaporator Fan and Motor with EcoBlue™ Technology:
 - 1. Direct Drive Evaporator Fan Motor:
 - a. Shall be a ECM motor design.
 - b. Shall have permanently lubricated bearings.
 - c. Shall have inherent automatic-reset thermal overload protection.
 - d. Shall have slow ramp up to speed capabilities.
 - e. Shall require no fan/motor belts for operation, adjustments and or initial fan speed set up.
 - f. Fan DC voltage set up on Unit Control Board can eliminate the need of removal of blower access door, required on conventional belt drive systems.
 - g. Shall be internally protected from electrical phase reversal and loss.
 - 2. Evaporator Fan:
 - a. Shall be easily set with selection switch and adjustment pot on unit control board or through SystemVu™ controller.
- b. On all sizes 04-06 which have two stage cooling capacity control, the indoor fan speed is automatically controlled to meet the AHRI performance requirement with 75% low fan speed and 100% at full fan speed operation.
- c. Blower fan shall be a Vane Axial fan design with 75% less moving parts than a conventional belt drive system.
- d. Shall be constructed of a cast aluminum stator and high impact composite material on rotor and air inlet casing.
- e. Shall be a patented / pending design with a corrosion resistant material and dynamically balanced.
- f. Shall have slow ramp up to speed capabilities to help reduce sound and comfort issues typically associated with single speed belt drive systems.
- g. Shall be a slide out design with two screw removal.
- 3. Shall include an easily accessible Unit Control Board to conveniently and safely provide connection points for vital control functions such as: smoke detectors, phase monitor, economizer, thermostat, DDC control options, and low and high pressure switches. Controller shall also provide an intuitive means to adjust the indoor fan speed through a simple switch and pot adjustment design.
- L. (23 81 19.13.L.) Condenser Fans and Motors:
 - 1. Condenser Fan Motors:
 - a. Shall be a totally enclosed motor.
 - b. Shall use permanently lubricated bearings.
 - c. Shall have inherent thermal overload protection with an automatic reset feature.
 - d. Shall use a shaft-down design on all sizes.
 - 2. Condenser Fans:
 - a. Shall be a direct-driven propeller type fan constructed of high impact composite material.
 - b. Shall have high impact composite blades completely formed into one piece without blade fasteners or connectors and shall be dynamically balanced.
- M. (23 81 19.13.M.) Special Features Options and Accessories:
 - 1. Integrated EconomizerONE and EconoMiSer® 2 Low Leak Rate Models. (Both are factory-installed on 3-phase models only. Both are field-installed on all 3 and 1-phase models.)
 - a. Integrated, gear driven opposing modulating blade design type capable of simultaneous economizer and compressor operation.
 - b. Independent modules for vertical or horizontal return configuration shall be available.

Vertical return modules shall be available as a factory installed option.

- c. Damper blades shall be galvanized steel with composite gears. Plastic or composite blades on intake or return shall not be acceptable.
- d. Shall include all hardware and controls to provide free cooling with outdoor air when temperature and/or humidity are below set points.
- e. Shall be equipped with gear driven dampers for both the outdoor ventilation air and the return air for positive air stream control.
- f. Low leak rate shall be equipped with dampers not to exceed 2% leakage at 1 in. wg pressure differential.
- g. Economizer controller on EconomizerONE (field-installed only) models shall be the Siemens POL224 that provides:
 - 1) Combined minimum and DCV maximum damper position potentiometers with compressor staging relay.
 - 2) Functions with solid-state analog enthalpy or dry bulb changeover control sensing.
 - 3) LED indication for free cooling, sensor, and damper operation.
 - 4) One-line LCD interface screen for setup, configuration and troubleshooting.
 - 5) On-board Fault Detection and Diagnostics (FDD) that senses and alerts when the economizer is not operating properly, per California Title 24, ASHRAE 90.1 and IECC¹.
 - 6) Sensor failure loss of communication identification.
 - 7) Capabilities for use with multiple-speed or single speed indoor fan systems.
 - 8) Digital sensors: Dry bulb and Enthalpy.
- h. Economizer controller on EconoMi\$er[®] 2 models with RTU Open or SystemVu controllers shall be a 4-20mA design controlled directly by the controller. RTU Open and SystemVu controllers meet California Title 24, ASHRAE 90.1 and IECC Fault Detection and Diagnostic (FDD) requirements.
- i. Shall be capable of introducing up to 100% outdoor air.
- j. Shall be equipped with a barometric relief damper capable of relieving up to 100% return air and contain seals that meet ASHRAE 90.1 requirements.
- k. Shall be designed to close damper(s) during loss-of-power situations with spring return built into motor.

- l. Dry bulb outdoor air temperature sensor shall be provided as standard. Enthalpy sensor is also available on factory installed only. Outdoor air sensor set point shall be adjustable and shall range from 40°F to 100°F (4°C to 38°C). Additional sensor options shall be available as accessories.
 - m. The economizer controller shall also provide control of an accessory power exhaust unit function. Factory set at 100%, with a range of 0% to 100%.
 - n. The economizer shall maintain minimum airflow into the building during occupied period and provide design ventilation rate for full occupancy.
 - o. Dampers shall be completely closed when the unit is in the unoccupied mode.
 - p. Economizer controller shall accept a 0 to 10 vdc CO₂ sensor input for IAQ/DCV control. In this mode, dampers shall modulate the outdoor air damper to provide ventilation based on the sensor input.
 - q. Compressor lockout temperature on POL224 control is adjustable from -45°F to 80°F (-43 to 26°C), set at a factory default of 32°F (0°C).
 - r. Actuator shall be direct coupled to economizer gear. No linkage arms or control rods shall be acceptable.
 - s. Contains LED indication for free cooling, sensor, and damper operation.
2. Integrated EconomizerONE and EconoMi\$er[®] 2 Ultra Low Leak Rate Models. (Factory installed on 3-phase models only. Field installed on all 3 and 1-phase models.)
- a. Integrated, gear driven opposing modulating blade design type capable of simultaneous economizer and compressor operation.
 - b. Independent modules for vertical or horizontal return configuration shall be available. Vertical return modules shall be available as a factory-installed option.
 - c. Damper blades shall be galvanized steel with composite gears. Plastic or composite blades on intake or return shall not be acceptable.
 - d. Shall include all hardware and controls to provide free cooling with outdoor air when temperature and/or humidity are below set points.
 - e. Shall be equipped with gear driven dampers for both the outdoor ventilation air and the return air for positive air stream control.
 - f. Ultra Low Leak design meets California Title 24 section 140.4 and ASHRAE 90.1 requirements for 4 cfm per sq ft on the outside air dampers and 10 cfm per sq ft on the return dampers.

1. Third-party trademarks and logos are the property of their respective owners.

- g. Economizer controller on EconomizerONE models shall be the Siemens POL224 that provides:
 - 1) One-line LCD interface screen for setup, configuration and troubleshooting.
 - 2) On-board Fault Detection and Diagnostics (FDD) that senses and alerts when the economizer is not operating properly, per California Title 24, ASHRAE 90.1 and IECC.
 - 3) Sensor failure loss of communication identification.
 - 4) Capabilities for use with multiple-speed indoor fan systems.
 - 5) Digital sensors: Dry bulb and Enthalpy.
 - h. Economizer controller on EconoMiSer® 2 models with RTU Open or SystemVu controls shall be a 4 to 20mA design controlled directly by the controller. RTU Open and SystemVu meet California Title 24, ASHRAE 90.1 and IECC Fault Detection and Diagnostic (FDD) requirements.
 - i. Shall be capable of introducing up to 100% outdoor air.
 - j. Shall be equipped with a barometric relief damper capable of relieving up to 100% return air and contain seals that meet ASHRAE 90.1 requirements.
 - k. Shall be designed to close damper(s) during loss-of-power situations with spring return built into motor.
 - l. Dry bulb outdoor air temperature sensor shall be provided as standard. Enthalpy sensor is also available on factory installed only. Outdoor air sensor set point shall be adjustable and shall range from 40°F to 100°F (4°C to 38°C). Additional sensor options shall be available as accessories.
 - m. The economizer controller shall also provide control of an accessory power exhaust unit function. Factory set at 100%, with a range of 0% to 100%.
 - n. The economizer shall maintain minimum airflow into the building during occupied period and provide design ventilation rate for full occupancy.
 - o. Dampers shall be completely closed when the unit is in the unoccupied mode.
 - p. Economizer controller shall accept a 0 to 10 vdc CO₂ sensor input for IAQ/DCV control. In this mode, dampers shall modulate the outdoor air damper to provide ventilation based on the sensor input.
 - q. Compressor lockout temperature on POL224 control is adjustable from -45°F to 80°F (-43 to 26°C), set at a factory default of 32°F (0°C).
 - r. Actuator shall be direct coupled to economizer gear. No linkage arms or control rods shall be acceptable.
 - s. Contains LED indication for free cooling, sensor, and damper operation.
- 3. Wi-Fi/WLAN Stick for EconomizerONE POL224 (field-installed):

This item allows use of the Siemens Climatix™1 mobile application.
 - 4. Two-Position Damper (field-installed only):
 - a. Damper shall be a Two-Position Damper. Damper travel shall be from the full closed position to the field adjustable %-open set point.
 - b. Damper shall include adjustable damper travel from 25% to 100% (full open).
 - c. Damper shall include single or dual blade, gear driven dampers and actuator motor.
 - d. Actuator shall be direct coupled to damper gear. No linkage arms or control rods shall be acceptable.
 - e. Damper will admit up to 100% outdoor air for applicable rooftop units.
 - f. Damper shall close upon indoor (evaporator) fan shutoff and/or loss of power.
 - g. The damper actuator shall plug into the rooftop unit's wiring harness plug. No hard wiring shall be required.
 - h. Outside air hood shall include aluminum water entrainment filter.
 - 5. Manual Damper (field-installed only):
 - a. Manual damper package shall consist of damper, air inlet screen, and rain hood which can be pre-set to admit up to 25% or 50% outdoor air for year round ventilation.
 - 6. Low Ambient Control Package:
 - a. Controller shall control coil head pressure by condenser fan speed modulation or condenser fan cycling and wind baffles.
 - b. Shall consist of solid-state control and condenser coil temperature sensor to maintain condensing temperature between 90°F (32°C) and 110°F (43°C) at outdoor ambient temperatures down to -20°F (-29°C).
 - 7. Condenser Coil Hail Guard Assembly (Factory-installed on 3-phase models only. Field-installed on all 3 and 1-phase models.)
 - a. Shall protect against damage from hail.
 - b. Shall be either hood style or louvered.

1. Third-party trademarks and logos are the property of their respective owners.

8. Unit-Mounted, Non-Fused Disconnect Switch (Available on units with MOCPs of 80 amps or less):
 - a. Switch shall be factory installed, internally mounted.
 - b. National Electric Code (NEC) and UL-approved non-fused switch shall provide unit power shutoff.
 - c. Shall be accessible from outside the unit.
 - d. Shall provide local shutdown and lockout capability.
 - e. Sized only for the unit as ordered from the factory. Does not accommodate field-installed devices.
 9. HACR Breaker:
 - a. These manual reset devices provide overload and short circuit protection for the unit. Factory wired and mounted with the units, with access cover to help provide environmental protection. On 575V applications, HACR breaker can only be used with WYE power distribution systems. Use on Delta power distribution systems is prohibited.
 - b. Sized only for the unit as ordered from the factory. Does not accommodate field-installed devices.
 10. Convenience Outlet:
 - a. Powered Convenience Outlet: (3-Phase Models Only)
 - 1) Outlet shall be powered from main line power to the rooftop unit.
 - 2) Outlet shall be powered from line side or load side of disconnect by installing contractor, as required by code. If outlet is powered from load side of disconnect, unit electrical ratings shall be UL certified and rated for additional outlet amperage.
 - 3) Outlet shall be factory-installed and internally mounted with easily accessible 115-v female receptacle.
 - 4) Outlet shall include 15 amp GFI receptacles with independent fuse protection.
 - 5) Voltage required to operate convenience outlet shall be provided by a factory installed step-down transformer.
 - 6) Outlet shall be accessible from outside the unit.
 - 7) Outlet shall include a field installed "Wet in Use" cover.
 - b. Factory-Installed Non-Powered Convenience Outlet:
 - 1) Outlet shall be powered from a separate 115/120v power source.
 - 2) A transformer shall not be included.
 - 3) Outlet shall be factory-installed and internally mounted with easily accessible 115-v female receptacle.
 - 4) Outlet shall include 15 amp GFI receptacles with independent fuse protection.
 - 5) Outlet shall be accessible from outside the unit.
 - 6) Outlet shall include a field installed "Wet in Use" cover.
 - c. Field-Installed Non-Powered Convenience Outlet:
 - 1) Outlet shall be powered from a separate 115/120v power source.
 - 2) A transformer shall not be included.
 - 3) Outlet shall be field-installed and internally mounted with easily accessible 115-v female receptacle.
 - 4) Outlet shall include 20 amp GFI receptacles. This kit provides a flexible installation method which allows code compliance for height requirements of the GFCI outlet from the finished roof surface as well as the capability to relocate the outlet to a more convenient location.
 - 5) Outlet shall be accessible from outside the unit.
 - 6) Outlet shall include a field installed "Wet in Use" cover.
11. Thru-the-Base Connectors:
 - a. Kits shall provide connectors to permit electrical connections to be brought to the unit through the unit basepan.
 - b. Minimum of four connection locations per unit.
12. Propeller Power Exhaust:
 - a. Power exhaust shall be used in conjunction with an integrated economizer.
 - b. Independent modules for vertical or horizontal return configurations shall be available.
 - c. Horizontal power exhaust is shall be mounted in return ductwork.
 - d. Power exhaust shall be controlled by economizer controller operation. Exhaust fans shall be energized when dampers open past the 0 to 100% adjustable set point on the economizer control.
13. Roof Curbs (Vertical):
 - a. Full perimeter roof curb with exhaust capability providing separate air streams for energy recovery from the exhaust air without supply air contamination.
 - b. Formed galvanized steel with wood nailer strip and shall be capable of supporting entire unit weight.

- c. Permits installation and securing of ductwork to curb prior to mounting unit on the curb.
- 14. Outdoor Air Enthalpy Sensor:
 - a. The outdoor air enthalpy sensor shall be used to provide single enthalpy control. When used in conjunction with a return air enthalpy sensor, the unit will provide differential enthalpy control. The sensor allows the unit to determine if outside air is suitable for free cooling.
- 15. Return Air Enthalpy Sensor:
 - a. The return air enthalpy sensor shall be used in conjunction with an outdoor air enthalpy sensor to provide differential enthalpy control.
- 16. Indoor Air Quality (CO₂) Sensor:
 - a. Shall be able to provide demand ventilation indoor air quality (IAQ) control.
 - b. The IAQ sensor shall be available in duct mount, wall mount, or wall mount with LED display. The set point shall have adjustment capability.
- 17. Smoke Detectors (factory-installed only):
 - a. Shall be a four-wire controller and detector.
 - b. Shall be environmental compensated with differential sensing for reliable, stable, and drift-free sensitivity.
 - c. Shall use magnet-activated test/reset sensor switches.
 - d. Shall have tool-less connection terminal access.
 - e. Shall have a recessed momentary switch for testing and resetting the detector.
 - f. Controller shall include:
 - 1) One set of normally open alarm initiation contacts for connection to an initiating device circuit on a fire alarm control panel.
 - 2) Two Form-C auxiliary alarm relays for interface with rooftop unit or other equipment.
 - 3) One Form-C supervision (trouble) relay to control the operation of the Trouble LED on a remote test/reset station.
 - 4) Capable of direct connection to two individual detector modules.
 - 5) Can be wired to up to 14 other duct smoke detectors for multiple fan shut-down applications.
- 18. Winter Start Kit:
 - a. Shall contain a bypass device around the low pressure switch.
 - b. Shall be required when mechanical cooling is required down to 25°F (-4°C).
- c. Shall not be required to operate on an economizer when below an outdoor ambient of 35°F (2°C).
- 19. Time Guard Control Circuit:
 - a. Shall prevent compressor short-cycling by providing a 5 minute delay (±2 minutes) before restarting a compressor after shut-down for any reason.
 - b. One device shall be required per compressor.
- 20. Hinged Access Panels:
 - a. Shall provide easy access through integrated quarter turn latches.
 - b. Shall be on major panels of: filter, control box, fan motor, and compressor.
- 21. Condensate Overflow Switch:
 - a. This sensor and related controller monitors the condensate level in the drain pan and shuts down compression operation when overflow conditions occur. It includes:
 - 1) Indicator light — solid red (more than 10 seconds on water contact – compressors disabled), blinking red (sensor disconnected).
 - 2) 10 second delay to break — eliminates nuisance trips from splashing or waves in pan (sensor needs 10 seconds of constant water contact before tripping).
 - 3) Disables the compressor(s) operation when condensate plug is detected, but still allows fans to run for economizer.
- 22. Foil Faced Insulation:
 - a. Throughout unit cabinet air stream, non-fibrous and cleanable foil faced insulation is used.
- 23. MERV-13 Return Air Filters:
 - a. Factory option to upgrade standard unit filters to MERV-13 filters.
- 24. Phase Monitor Control:
 - a. Shall monitor the sequence of three phase electrical system to provide a phase reversal protection.
 - b. Shall monitor the three phase voltage inputs to provide a phase loss protection for the three phase device.
 - c. Will work on either a Delta or Wye power connection.
- 25. Horn/Strobe Annunciator:
 - a. Provides an audible/visual signaling device for use with factory-installed option or field installed accessory smoke detectors.
 - 1) Requires installation of a field-supplied 24-v transformer suitable for 4.2 VA (AC) or 3.0 VA (DC) per horn/strobe accessory.

Guide specifications (cont)

- 2) Requires field-supplied electrical box, North American 1-gang box, 2 in. (51 mm) x 4 in. (102 mm).
 - 3) Shall have a clear colored lens.
26. Electric Heat:
- a. Heating Section:
 - 1) Heater element open coil resistance wire, nickel-chrome alloy, 0.29 in. inside diameter, strung through ceramic insulators mounted on metal frame. Coil ends are staked and welded to terminal screw slots.
 - 2) Heater assemblies are provided with integral fusing for protection of internal heater circuits not exceeding 48 amps each. Auto reset thermo limit controls, magnetic heater contactors (24-v coil) and terminal block all mounted in electric heater control box (minimum 18 ga galvanized steel) attached to end of heater assembly.

