

2-1/2" ANGLE HOSE VALVE

Figure 1201



NFP120101A



NFP120103A

FEATURES & BENEFITS

- Sizes:
 - 2-1/2 FNPT x MNST
 - 2-1/2 Grooved x MNST
- UL/FM approved
- Body Material: Brass
- Finish: Rough brass
- Hand Wheel: Ductile iron (red)
- Max Pressure: 300 psi

INSTALLATION

Use an approved thread sealant on the threads the hose valve will be installed on. **DO NOT OVERTIGHTEN**. Overtightening may cause cracks or deformities in the valve body which could lead to failure.



*Not for use in potable systems

2-1/2" ANGLE HOSE VALVE

Figure 1201

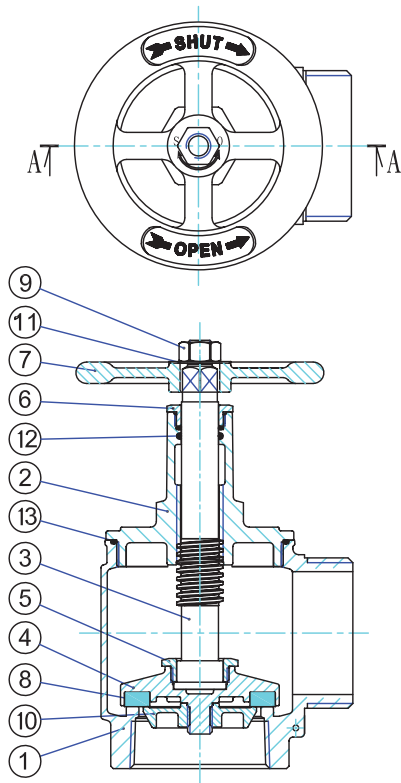

MATERIAL CHART

NO.	PART NAME	MATERIAL
1	Body	Brass ASTM B584
2	Bonnet	Brass ASTM B584
3	Stem	Brass
4	Disc Holder	Forged Brass
5	Disc Nut	Brass
6	Packing Nut	Brass
7	Hand Wheel	Ductile Iron
8	Seal	NBR
9	Nut	Stainless Steel
10	Clamping Ring	Forged Brass
11	Name Plate	Aluminum
12	O-Ring (2)	NBR
13	O-Ring	NBR

DIMENSION (INCHES)

PART #	INLET	OUTLET	A	B	C	D	EØ
NFP120101A	2-1/2" FNPT	2-1/2" MNST	8.74	10.65	2.76	3.11	5.04
NFP120103A	2-1/2" Grooved	2-1/2" MNST	9.55	11.46	3.56	3.11	5.04

