



THE FORD METER BOX COMPANY, INC.
CERTIFIED TO ISO 9001:2015
10002505

Section I

Ford® Check Valves, Retrossetters and Cut-in Check Valves



Contents

Why Provide Residential Backflow Prevention	4
Sample Dual Check Ordinance	4
Ford Dual and Single Check Valve Features and Specifications	5 & 6
Ford Cartridge Style Dual Check Valves	
Pressure Drop Tables for Cartridge Style Dual Check Valves	7
Angle Cartridge Dual Check Valves (in-line accessible)	8
Straight Cartridge Style Dual Check Valves (in-line accessible)	9
Straight Cartridge Style Dual Check Valves	9
Ford Dual Cascading Check Valves	
Angle Cascading Dual Check Valves (in-line accessible)	10
Straight Cascading Dual Check Valves (in-line accessible)	10
Ford Single Check Valves	
Angle Check Valves (in-line accessible)	11
Straight Check Valves (in-line accessible)	12 & 13
Ford Check Valves with Flanged Inlet for 1-1/2" and 2" Meters	
Angle Dual Check Valve for 1-1/2" and 2" Flanged Meters	14
Angle Check Valves for 1-1/2" and 2" Flanged Meters	14
Straight Check Valves for 1-1/2" and 2" Flanged Meters	14
Check Valves for Kornerhorn Applications	
Straight Cartridge Style Dual Check Valve for Kornerhorn	15
Straight Dual Check Valve for Kornerhorn	15
Straight Single Check Valve For Kornerhorn	15
Check Valves for Special Applications	
Straight Cartridge Style Dual Check Valves with Male Kornerhorn Thread Outlet	16
Straight Single and Dual Cut-In Check Valves	16
Check Valve Replacement Kits	17
Ford Cut-in Check Valve Assemblies for Retrofitting	
Into Existing Coppersetters and Resetters	18 & 19
Ford Retrosetters	20 - 24
Ford Retro-Z Style Retrosetters	25
Retrosetter Sampling Station	26 & 27
Warranty	28

Ford offers many products that are classified to ANSI/NSF Standard 61. To verify if a product is classified to ANSI/NSF Standard 61, contact the Ford Meter Box Customer Service Department at 260-563-3171 or visit fordmeterbox.com. Ford Meter Box meets your need for ANSI/NSF Standard 61 approved items with products that are proven and reliable.

Due to design improvements, product images in the catalog do not always reflect the most current design detail.

Ford Meter Box no-lead brass products manufactured from UNS/CDA No. 89833 alloy shall contain no more than 0.25% total lead content by weight.

Ford, Ford Meter Box and Uni-Flange are trademarks of The Ford Meter Box Company, Inc. registered in the U.S.

Ford Check Valve Numbering System

TYPES OF *CHECK VALVES

- HA** = Angle Check Valve
- HHA** = Angle Cascading Dual Check Valve
- HHACR** = Angle Cascading Dual Check Valve (enhanced chlorine/chloramine resistance)
- HHCA** = Angle Cartridge Style Dual Check Valve
- HHCACR** = Angle Cartridge Style Dual Check Valve (enhanced chlorine/chloramine resistance)
- HS** = Straight Check Valve
- HHS** = Straight Cascading Dual Check Valve
- HHSCR** = Straight Cascading Dual Check Valve (enhanced chlorine/chloramine resistance)
- HHC** = Straight Cartridge Style Dual Check Valve (not in-line accessible)
- HHCCR** = Straight Cartridge Style Dual Check Valve (enhanced chlorine/chloramine resistance)
- HHCH** = Straight Cartridge Style Dual Check Valve (in-line accessible)
- HHCHCR** = Straight Cartridge Style Dual Check Valve (in-line accessible) (enhanced chlorine/chloramine resistance)
- HFA** = Flanged Angle Check Valve
- HHFA** = Flanged Angle Dual Check Valve
- HFS** = Flanged Straight Check Valve

SIZE OF INLETS - OUTLETS (one end - other end)

- 1** = 1/2"
- 2** = 5/8"
- 3** = 3/4"
- 4** = 1"
- 5** = 1-1/4"
- 6** = 1-1/2"
- 7** = 2"

METER CONNECTION SIZE

- 1** = 5/8"
- 2** = 5/8"x3/4" & 3/4"
- 4** = 1"
- 6** = 1-1/2"
- 7** = 2"

*Note: All Ford Check Valves are accessible for in-line maintenance unless otherwise indicated.

▲ NO-LEAD ALLOY

HHCA 3 4 - 3 2 3 - G - NL

TYPES OF INLETS - OUTLETS (one end - other end)

- 1** = Female Iron Pipe Threads
- 2** = Flare Copper Tube Nut
- 3** = Meter Nut or Flange
- 4** = Pack Joint for Plastic or Copper Tube (CTS)
- 5** = Pack Joint for Iron Pipe
- 6** = Pack Joint for PE Pipe
- 7** = Pack Joint for PVC Pipe (Schedule 40 and 80)
- 8** = Male Iron Pipe Threads
- 9** = Yoke Nose

VALVE SIZE

- 3** = 3/4"
- 4** = 1"
- 6** = 1-1/2"
- 7** = 2"

OPTIONAL FEATURES

- D** = Test/Drain Valve
- G** = Grip Joint
- 3TV** = Test/Drain Valve on Top of Cartridge Dual Check Valve Access Cap
- Q** = Quick Joint
- PE** = Plain End
- TW-Q** = CTS Quick Joint with Tracer Wire Terminal
- U-AWT** = Ultra-Tite (components assembled watertight)

▲ Ford Meter Box no-lead brass products manufactured from UNS/CDA No. 89833 alloy shall contain no more than 0.25% total lead content by weight.

Parties responsible for monitoring and maintaining proper water system design must exercise full responsibility in understanding and upholding the full intent and scope of applicable lead laws.

Why Provide Residential Backflow Prevention?

From EPA Cross-Connection Control Manual

The need to furnish reliable and inexpensive back-siphonage and backpressure protection for individual residences resulted in the debut of the residential dual check. Protection of the main potable supply from household hazards such as home photography chemicals, toxic insect and garden sprays, termite control pesticides used by exterminators, etc., reinforced a true need for such a device. Figure 26 shows a cutaway of the device.

It is sized for 3/4 and 1-inch service lines and is installed immediately downstream of the water meter. The use of plastic check modules and elimination of test cocks and gate valves keeps the cost reasonable while providing good, dependable protection. Typical installations are shown in Figures 27 and 28.

FIGURE 26
Residential Dual Check

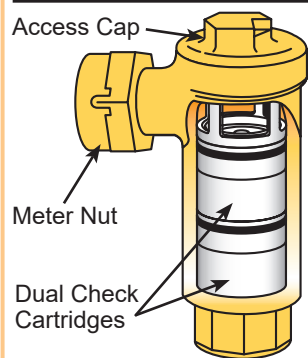

FIGURE 27
Residential Installation

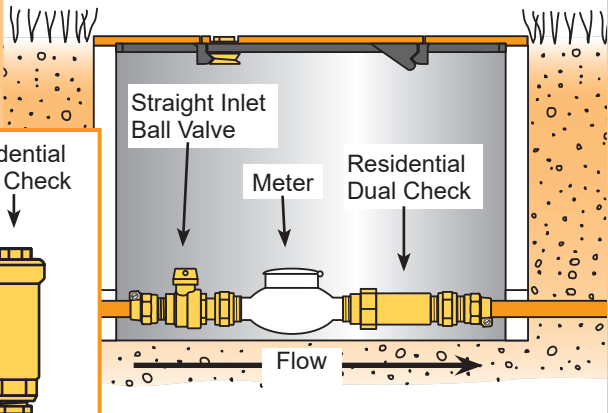
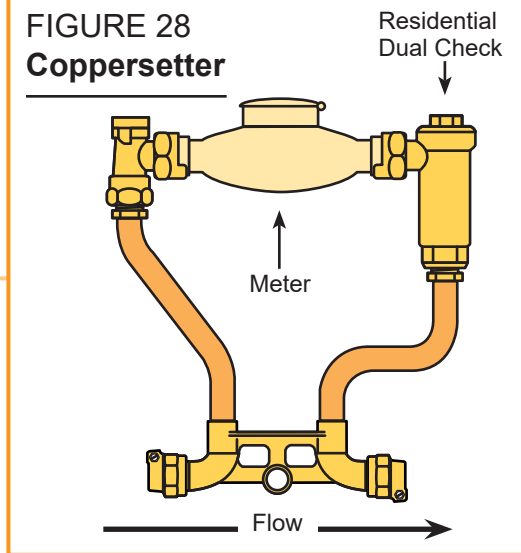

FIGURE 28
Coppersetter



Sample Dual Check Ordinance

Effective the date of acceptance of this Cross-Connection Control Program for the Town of (), all new residential buildings will be required to install a residential dual check device immediately downstream of the water meter. Installation of this residential dual check device on a retrofit basis on existing service lines will be instituted at a time and at a potential cost to the homeowner as deemed necessary by the department.

The owner must be aware that installation of a residential dual check valve results in a potential closed plumbing system within the residence. As such, provisions may have to be made by the owner to provide for thermal expansion within this closed loop system; for example, the installation of thermal expansion devices and/or pressure relief valves.

Ford Dual Check Valves are intended for service use as stipulated within the scope of ASSE 1024.

Delivering top quality water to the point of use is the responsibility of every utility.

Ford Dual Check Valves can help you meet that responsibility.

A lot has changed since the “good old days” when a utility’s responsibility for water quality ended at the outlet of the water meter. The *Safe Drinking Water Act*, and a host of state and local regulations, now define the utility as responsible for delivery of quality water to the faucet inside the customer’s home or business. The entry of objectionable or hazardous material into the customer’s plumbing may expose your utility, and you personally, to expensive and time-consuming legal action.

Many state health agencies now require dual check valves be installed on all new domestic services. A number of concerned utilities are putting dual checks on existing services as well. All of these programs for dual check installation, whether mandated or not, are for the purpose of reducing utility liability and for protecting the end user. Ford Dual Check Valves are designed to make **your** program of domestic backflow protection simple and cost effective. See Catalog Sections C, E, F and FA for additional dual check valve service line installations.

Ford Dual Check Valves are intended for service use as stipulated within the scope of ASSE 1024.



Ford Dual Check Valves are designed for installation at the water meter for maximum convenience.

Formerly, dual check valves were available only with threaded end connections, since they were designed for installation by the plumber. The working parts of these valves could not be inspected or replaced without removing the valve from the line, a time-consuming and costly job. Ford Dual Check Valves were designed from the start to be installed at the outlet of the water meter. Available in straight and angle styles, most come with swivel meter nuts on the inlet side; they can be used by themselves at the outlet of the meter or can be located on the outlet side of a Ford Coppersetter, Resetter or a Long Yokebox. Dual checks are also available with inlet yoke threads for direct attachment to a Ford Yoke Bar. See Catalog Sections C, E, F and FA for additional dual check valve service line installations.

Ford Dual Check Valves were designed for ease of maintenance. Removable “O” ring sealed access caps allow for quick and easy inspection and replacement of the internal working parts, without removing the valve from the line. Since the valve is located at the outlet of the meter, your meter repair crews can assist with maintenance by looking for water flow out of the check when replacing the water meter. No water flow means that positive backflow protection is being provided by the dual check.

Ford Dual Check Valves are intended for service use as stipulated within the scope of ASSE 1024.

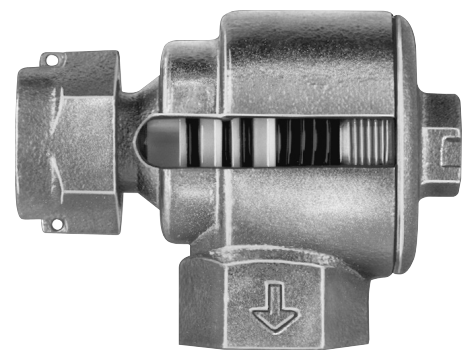

Ford Single Check Valves provide deterrence for minimum requirements.

On services where an approved backflow preventer is not desired or required, a Ford Single Check Valve may be installed. A single check valve deters hot water backflow from a water heater, which could damage the working parts of a water meter. They also keep water within the house plumbing from flowing into a meter pit or onto a basement floor when a meter is removed from service.

Ford Single Check Valves are available in in-line accessible angle and straight styles and in sizes from 3/4" through 2". They can be an integral part of a Ford Coppersetter, Pit Setter or Iron Yoke. See Catalog Sections E, F and FA for additional dual check valve service line installations.

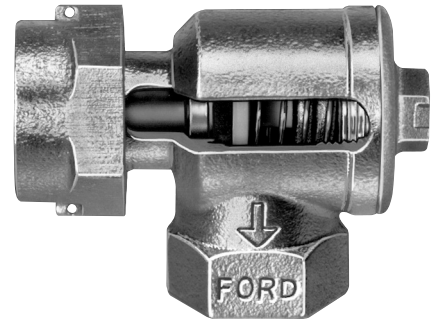

Ford is THE choice of Check Valves for Water Utilities



Standard #1024
APPROVED

In planning your domestic service backflow protection program, remember that only Ford offers these important advantages:

1. The only full line of ASSE approved dual checks designed for use at the water meter.
2. The only full line of ASSE approved dual checks with removable access caps (in-line accessible) for easy maintenance. Replacement kits are listed within this catalog.
3. ASSE approved dual checks available as integral parts of Ford Coppersetters, Resettters, Iron Yoke Settings and Yokeboxes. See Catalog Sections C, E, F and FA.
4. Check valves that offer the lowest water pressure head loss figures in the industry.

Cartridge Style Dual Check Valves

Ford Cartridge Style Dual Check Valves are approved by the American Society of Sanitary Engineering and meet, or exceed, **all** requirements of ASSE Standard #1024.



Water pressure head loss through the checks is lower than the maximum allowed by ASSE, ensuring adequate delivery to your customers. Excellent corrosion resistance is provided by the use of stainless steel and acetal plastic working parts. For systems with higher concentrations and longer durations of chlorine/chloramine exposure, Ford offers a special polysulfone/silicone cartridge for enhanced chlorine/chloramine resistance. To order, see option information under product listings. The body is cast from AWWA C800 Standard (ASTM B584, UNS C89833 no-lead brass alloy).

The unique angle design of the Ford Angle Cartridge Dual Check Valve features a removable "O" ring sealed cap **at the top of the valve**. This allows easy in-line access to the dual check assemblies for maintenance, inspection or replacement. As an added measure of protection, the Ford Angle Cartridge design will deter backflow **even if one of the cartridge assemblies is removed** from the valve body.

Ford Cartridge Dual Check Valves are available in in-line accessible angle and straight styles. They can be an integral part of a Ford Coppersetter, Pit Setter, Iron Yoke Settings and Yokeboxes. See Catalog Sections C, E, F and FA.

Note: Ford Dual Check Valves are intended for service use as stipulated by ASSE 1024.

Pressure Drop - 5/8" x 3/4" and 3/4" Cartridge Dual Check Valves

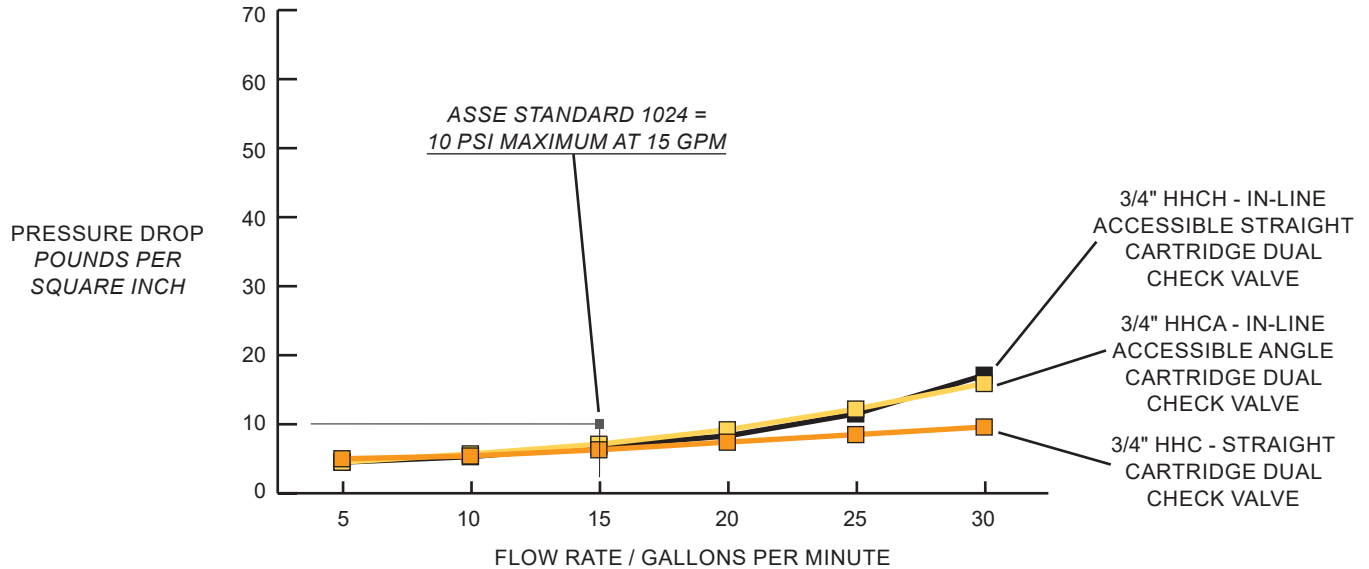

Pressure Drop - 1" Cartridge Dual Check Valves

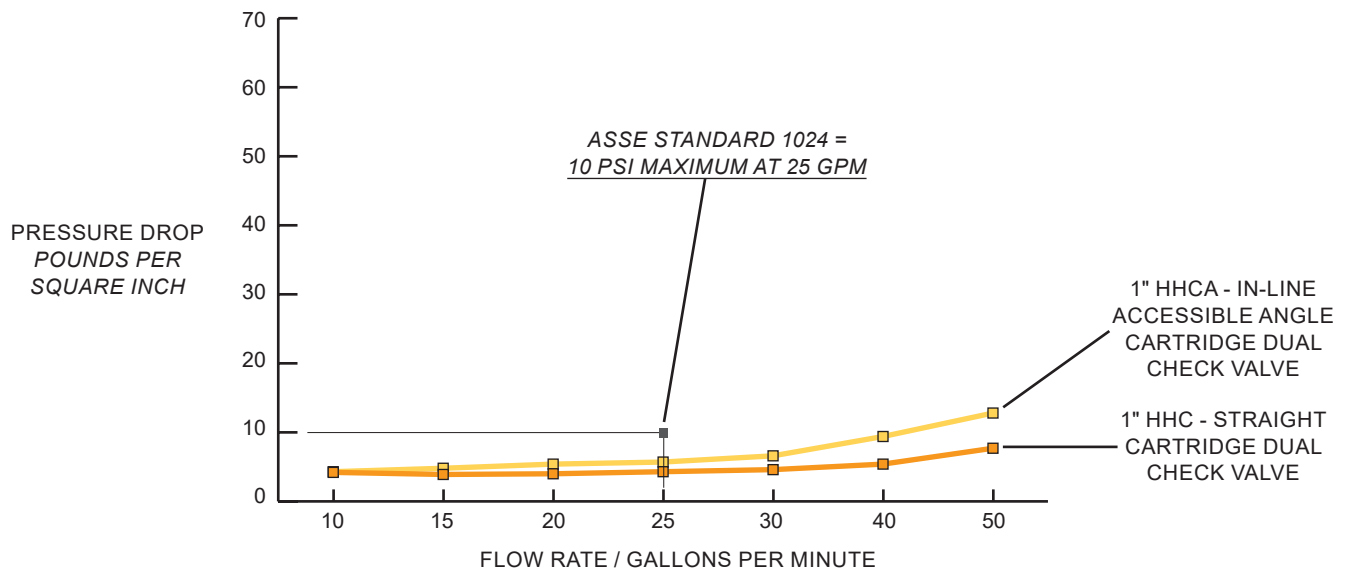

Cartridge Style Dual Check Valves

Angle Cartridge Style Dual Check Valves (in-line accessible)



HHCA31-323-NL



HHCA34-323-NL



HHCA92-323-NL



HHCA94-323-NL

METER SWIVEL NUT INLET BY FEMALE IRON PIPE THREAD OUTLET

CATALOG NUMBER	DESCRIPTION			APPROX. Wt. LBS.
	VALVE SIZE	METER SIZE INLET	OUTLET SIZE	
HHCA31-313-NL	3/4"	5/8"	3/4"	1.7
ε HHCA31-323-NL	3/4"	5/8"x3/4" and 3/4"	3/4"	1.8
HHCA31-344-NL	3/4"	1"	1"	2.0
ε HHCA31-444-NL	1"	1"	1"	3.1

METER SWIVEL NUT INLET BY FLARE COPPER OUTLET

CATALOG NUMBER	DESCRIPTION			APPROX. Wt. LBS.
	VALVE SIZE	METER SIZE INLET	OUTLET SIZE	
HHCA32-323-NL	3/4"	5/8"x3/4" and 3/4"	3/4"	2.3
HHCA32-444-NL	1"	1"	1"	3.9

METER SWIVEL NUT INLET BY PACK JOINT FOR COPPER OR PLASTIC TUBING (CTS)* OUTLET

CATALOG NUMBER	DESCRIPTION			APPROX. Wt. LBS.
	VALVE SIZE	METER SIZE INLET	OUTLET SIZE	
▶ ♦ HHCA34-323-NL	3/4"	5/8"x3/4" and 3/4"	3/4"	2.2
▶ HHCA34-444-NL	1"	1"	1"	3.5

METER YOKE INLET BY FEMALE IRON PIPE THREAD OUTLET

CATALOG NUMBER	DESCRIPTION			APPROX. Wt. LBS.
	VALVE SIZE	METER SIZE INLET	OUTLET SIZE	
HHCA91-313-NL	3/4"	5/8"	3/4"	1.7
HHCA91-323-NL	3/4"	5/8"x3/4" and 3/4"	3/4"	1.7
HHCA91-344-NL	3/4"	1"	1"	2.1
HHCA91-444-NL	1"	1"	1"	3.0

METER YOKE INLET BY FLARE COPPER OUTLET

CATALOG NUMBER	DESCRIPTION			APPROX. Wt. LBS.
	VALVE SIZE	METER SIZE INLET	OUTLET SIZE	
HHCA92-313-NL	3/4"	5/8"	3/4"	2.2
HHCA92-323-NL	3/4"	5/8"x3/4" and 3/4"	3/4"	2.1
HHCA92-424-NL	1"	5/8"x3/4" and 3/4"	1"	3.6
HHCA92-444-NL	1"	1"	1"	3.9

METER YOKE INLET BY PACK JOINT FOR COPPER OR PLASTIC TUBING (CTS)* OUTLET

CATALOG NUMBER	DESCRIPTION			APPROX. Wt. LBS.
	VALVE SIZE	METER SIZE INLET	OUTLET SIZE	
▶ ♦ HHCA94-313-NL	3/4"	5/8"	3/4"	2.1
▶ ♦ HHCA94-323-NL	3/4"	5/8"x3/4" and 3/4"	3/4"	2.1
▶ HHCA94-324-NL	3/4"	5/8"x3/4" and 3/4"	1"	2.1
▶ ♦ HHCA94-414-NL	1"	5/8"	1"	3.0
▶ ♦ HHCA94-424-NL	1"	5/8"x3/4" and 3/4"	1"	3.4
▶ ♦ HHCA94-444-NL	1"	1"	1"	3.8

Options Available

* **Grip Joint** for CTS can be ordered by adding "-G" to the catalog number. Example: HHCA34-444-G-NL

♦ **Quick Joint** is available. Add "-Q" to this catalog number.

▶ **Ultra-Tite** compression is available. Add "-U-AWT" to the catalog number. (Consists of components assembled watertight.)

Drain/Test valve on top of the Access Cap (drains Inlet) is available for all cartridge dual check valves with access caps. Add "D" to the catalog number. Example: HHCA31-323D-NL

ε **A three-port bleeder** valve configuration is available for the HHCA31-323-NL and HHCA31-444-NL valve (catalog numbers HHCA31-323-3TV-NL and HHCA31-444-3TV-NL). Contact the factory for availability.

Cartridges are available with **enhanced chlorine/chloramine resistance**. Add "CR" to the end of the alpha code. Example: HHCACR31-323-NL.

Cartridge Style Dual Check Valves (continued)

Straight Cartridge Style Dual Check Valves (in-line accessible)



HHCH31-323-NL

METER SWIVEL NUT INLET BY FEMALE IRON PIPE THREAD OUTLET

CATALOG NUMBER	DESCRIPTION			APPROX. Wt. Lbs.
	VALVE SIZE	METER SIZE INLET	OUTLET SIZE	
**♦ HHCH31-323-NL	3/4"	5/8"x3/4" and 3/4"	3/4"	2.0
HHCH31-344-NL	3/4"	1"	1"	2.4

METER YOKE INLET BY FEMALE IRON PIPE THREAD OUTLET

♦ HHCH91-313-NL	3/4"	5/8"	3/4"	2.0
♦ HHCH91-323-NL	3/4"	5/8"x3/4" and 3/4"	3/4"	2.0

♦ Indicates **drain/test valve** (drains inlet) on the access cap (not on the side of the check valve). Add "D" to the catalog number. Example: HHCH31-323D-NL.

** An HHCH13-332-NL is available which attaches to the **inlet** of the meter. It is similar in size and features to the HHCH31-323-NL except the water flow is reversed.

Straight Cartridge Style Dual Check Valves (not in-line accessible)



HHC31-323-NL

METER SWIVEL NUT INLET BY FEMALE IRON PIPE THREAD OUTLET

CATALOG NUMBER	DESCRIPTION			APPROX. Wt. Lbs.
	VALVE SIZE	METER SIZE INLET	OUTLET SIZE	
HHC31-313-NL	3/4"	5/8"	3/4"	1.6
HHC31-323-NL	3/4"	5/8"x3/4" and 3/4"	3/4"	1.7
HHC31-444-NL	1"	1"	1"	2.8

METER SWIVEL NUT INLET BY PACK JOINT FOR COPPER OR PLASTIC TUBING (CTS)* OUTLET

▶ HHC34-323-NL	3/4"	5/8"x3/4" and 3/4"	3/4"	2.0
----------------	------	--------------------	------	-----

METER SWIVEL NUT INLET BY MALE IRON PIPE THREAD OUTLET

HHC38-313-NL	3/4"	5/8"	3/4"	1.5
HHC38-323-NL	3/4"	5/8"x3/4" and 3/4"	3/4"	1.7

FEMALE METER THREAD INLET BY MALE METER THREAD

CATALOG NUMBER	DESCRIPTION			APPROX. Wt. Lbs.
	VALVE SIZE	METER SIZE INLET	OUTLET SIZE	
HHCI33-311-NL	3/4"	5/8"	5/8"	1.4
HHCI33-322-NL	3/4"	5/8"x3/4" and 3/4"	5/8"x3/4" and 3/4"	1.4

METER SWIVEL NUT THREAD INLET BY MALE METER THREAD

CATALOG NUMBER	DESCRIPTION			APPROX. Wt. Lbs.
	VALVE SIZE	METER SIZE INLET	OUTLET SIZE	
HHC3MM-322-SN-NL	3/4"	5/8"x3/4" and 3/4"	5/8"x3/4" and 3/4"	1.8
HHC3MM-342-NL	3/4"	1"	5/8"x3/4" and 3/4"	1.8
HHC3MM-444-SN-NL	1"	1"	1"	2.7

INTEGRAL FEMALE METER THREAD UNION INLET BY MALE IRON PIPE THREAD OUTLET

CATALOG NUMBER	DESCRIPTION			APPROX. Wt. Lbs.
	VALVE SIZE	METER SIZE INLET	OUTLET SIZE	
HHCI38-313-NL	3/4"	5/8"	3/4"	1.4
HHCI38-323-NL	3/4"	5/8"x3/4" and 3/4"	3/4"	1.3

METER SWIVEL NUT INLET BY KORNERHORN THREAD OUTLET

CATALOG NUMBER	DESCRIPTION			APPROX. Wt. Lbs.
	VALVE SIZE	METER SIZE INLET	OUTLET SIZE	
HHC30-320-NL	3/4"	5/8"x3/4" and 3/4"	No. 1 Male Kornerhorn Thread for Pack Joint Assemblies (See Section B)	1.6

MALE IRON PIPE THREAD INLET BY KORNERHORN THREAD OUTLET

HHC80-330-NL	3/4"	3/4"	No. 1 Male Kornerhorn Thread for Pack Joint Assemblies (See Section B)	1.6
--------------	------	------	--	-----

FEMALE IRON PIPE THREAD INLET BY FEMALE IRON PIPE THREAD OUTLET

CATALOG NUMBER	DESCRIPTION			APPROX. Wt. Lbs.
	VALVE SIZE	METER SIZE INLET	OUTLET SIZE	
HHC11-333-NL	3/4"	3/4"	3/4"	1.5
HHC11-344-NL	3/4"	1"	1"	1.4
HHC11-444-NL	1"	1"	1"	2.5

MALE IRON PIPE THREAD INLET BY FEMALE IRON PIPE THREAD OUTLET

CATALOG NUMBER	DESCRIPTION			APPROX. Wt. Lbs.
	VALVE SIZE	METER SIZE INLET	OUTLET SIZE	
HHC81-333-NL	3/4"	3/4"	3/4"	1.6
HHC81-344-NL	3/4"	1"	1"	1.6
HHC81-444-NL	1"	1"	1"	2.5



HHC38-323-NL



HHCI33-311-NL

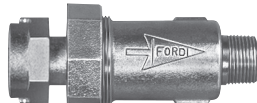

HHC3MM-342-NL



HHC30-320-NL

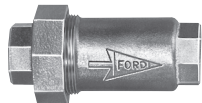

HHC11-333-NL



HHC81-333-NL

Options Available

Straight cartridge check valves for Kornerhorns are found on page 15.

* **Grip Joint** for CTS can be ordered by adding "-G" to the catalog number. Example: HHC34-323-G-NL

▶ **Ultra-Tite** compression is available. Add "-U-AWT" to the catalog number. (Consists of components assembled watertight.)

Cartridges are available with **enhanced chlorine/chloramine resistance**. Add "CR" to the end of the alpha code.

Example: HHCHCR31-323-NL.

Cartridge Style Dual Check Valves (continued)

Straight Cartridge Style Dual Check Valves (in-line accessible)

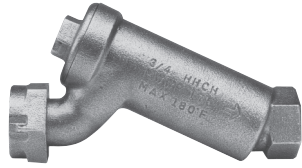

HHCH31-323-NL

METER SWIVEL NUT INLET BY FEMALE IRON PIPE THREAD OUTLET

CATALOG NUMBER	DESCRIPTION			APPROX. WT. LBS.
	VALVE SIZE	METER SIZE INLET	OUTLET SIZE	
**♦ HHCH31-323-NL	3/4"	5/8"x3/4" and 3/4"	3/4"	2.0
HHCH31-344-NL	3/4"	1"	1"	2.4

METER YOKE INLET BY FEMALE IRON PIPE THREAD OUTLET

♦ HHCH91-313-NL	3/4"	5/8"	3/4"	2.0
♦ HHCH91-323-NL	3/4"	5/8"x3/4" and 3/4"	3/4"	2.0

♦ Indicates **drain/test valve** (drains inlet) on the access cap (not on the side of the check valve). Add "D" to the catalog number. Example: HHCH31-323D-NL.

** An HHCH13-332-NL is available which attaches to the **inlet** of the meter. It is similar in size and features to the HHCH31-323-NL except the water flow is reversed.

Straight Cartridge Style Dual Check Valves (not in-line accessible)

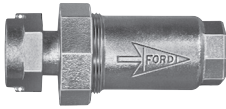

HHC31-323-NL

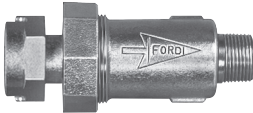

HHC38-323-NL

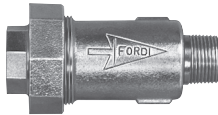

HHCI33-311-NL



HHC30-320-NL

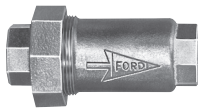

HHC11-333-NL



HHC81-333-NL

METER SWIVEL NUT INLET BY FEMALE IRON PIPE THREAD OUTLET

CATALOG NUMBER	DESCRIPTION			APPROX. WT. LBS.
	VALVE SIZE	METER SIZE INLET	OUTLET SIZE	
HHC31-313-NL	3/4"	5/8"	3/4"	1.6
HHC31-323-NL	3/4"	5/8"x3/4" and 3/4"	3/4"	1.7
HHC31-444-NL	1"	1"	1"	2.8

METER SWIVEL NUT INLET BY PACK JOINT FOR COPPER OR PLASTIC TUBING (CTS)* OUTLET

▶ HHC34-323-NL	3/4"	5/8"x3/4" and 3/4"	3/4"	2.0
----------------	------	--------------------	------	-----

METER SWIVEL NUT INLET BY MALE IRON PIPE THREAD OUTLET

HHC38-313-NL	3/4"	5/8"	3/4"	1.5
HHC38-323-NL	3/4"	5/8"x3/4" and 3/4"	3/4"	1.7

FEMALE METER THREAD INLET BY MALE METER THREAD

CATALOG NUMBER	DESCRIPTION			APPROX. WT. LBS.
	VALVE SIZE	METER SIZE INLET	OUTLET SIZE	
HHCI33-311-NL	3/4"	5/8"	5/8"	1.4
HHCI33-322-NL	3/4"	5/8"x3/4" and 3/4"	5/8"x3/4" and 3/4"	1.4
HHC3MM-342-NL	3/4"	1"	5/8"x3/4" and 3/4"	1.8

INTEGRAL FEMALE METER THREAD UNION INLET BY MALE IRON PIPE THREAD OUTLET

CATALOG NUMBER	DESCRIPTION			APPROX. WT. LBS.
	VALVE SIZE	METER SIZE INLET	OUTLET SIZE	
HHCI38-313-NL	3/4"	5/8"	3/4"	1.4
HHCI38-323-NL	3/4"	5/8"x3/4" and 3/4"	3/4"	1.3

METER SWIVEL NUT INLET BY KORNERHORN THREAD OUTLET

CATALOG NUMBER	DESCRIPTION			APPROX. WT. LBS.
	VALVE SIZE	METER SIZE INLET	OUTLET SIZE	
HHC30-320-NL	3/4"	5/8"x3/4" and 3/4"	No. 1 Male Kornerhorn Thread for Pack Joint Assemblies (See Section B)	1.6

MALE IRON PIPE THREAD INLET BY KORNERHORN THREAD OUTLET

HHC80-330-NL	3/4"	3/4"	No. 1 Male Kornerhorn Thread for Pack Joint Assemblies (See Section B)	1.6
--------------	------	------	--	-----

FEMALE IRON PIPE THREAD INLET BY FEMALE IRON PIPE THREAD OUTLET

CATALOG NUMBER	DESCRIPTION			APPROX. WT. LBS.
	VALVE SIZE	METER SIZE INLET	OUTLET SIZE	
HHC11-333-NL	3/4"	3/4"	3/4"	1.5
HHC11-344-NL	3/4"	1"	1"	1.4
HHC11-444-NL	1"	1"	1"	2.5

MALE IRON PIPE THREAD INLET BY FEMALE IRON PIPE THREAD OUTLET

CATALOG NUMBER	DESCRIPTION			APPROX. WT. LBS.
	VALVE SIZE	METER SIZE INLET	OUTLET SIZE	
HHC81-333-NL	3/4"	3/4"	3/4"	1.6
HHC81-344-NL	3/4"	1"	1"	1.6
HHC81-444-NL	1"	1"	1"	2.5

Options Available

Straight cartridge check valves for Kornerhorns are found on page 15.

* **Grip Joint** for CTS can be ordered by adding "-G" to the catalog number. Example: HHC34-323-G-NL

▶ **Ultra-Tite** compression is available. Add "-U-AWT" to the catalog number. (Consists of components assembled watertight.)

Cartridges are available with **enhanced chlorine/chloramine resistance**. Add "CR" to the end of the alpha code. Example: HHCHCR31-323-NL.

Cascading Dual Check Valves

Ford Dual Check Valves with a cascading check design are approved by the American Society of Sanitary Engineering and meet or exceed **all** the requirements of ASSE Standard #1024.

Water pressure head loss through the checks is lower than the maximum allowed by ASSE, ensuring adequate delivery to your customers. Excellent corrosion resistance is provided by the use of stainless steel and acetal plastic working parts and a body cast from AWWA C800 Standard (ASTM B584, UNS C89833 no-lead brass alloy).

The low head loss characteristics and compact size of these dual check valves is made possible by the unique "cascading" check design. Each check assembly is sealed by means of an "O" ring, and guide pins on the face of the plunger ensure positive centering of the "O" ring on the seat. This means a positive water tight seal against backpressure and back-siphonage.

Ford Cascading Dual Check Valves are available in in-line accessible angle and straight styles. They can be an integral part of a Ford Coppersetter, Pit Setter or Iron Yoke. See Catalog Sections E, F and FA.

Note: Ford Dual Check Valves are intended for service use as stipulated by ASSE 1024.

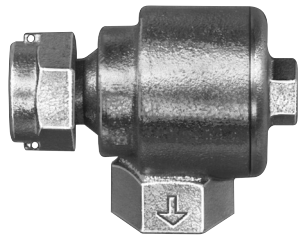

HHA31-313-NL

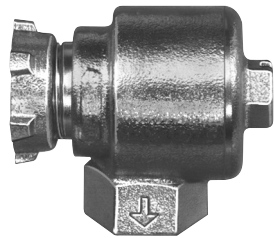

HHA91-323-NL



HHS31-323-NL



HHS91-323-NL

Angle Cascading Dual Check Valves (in-line accessible) WITH METER SWIVEL NUT INLET

CATALOG NUMBER	DESCRIPTION			APPROX. WT. LBS.
	VALVE SIZE	METER SIZE INLET	OUTLET SIZE & TYPE	
HHA31-313-NL	3/4"	5/8"	3/4" FIP	1.5
Δ HHA31-323-NL	3/4"	5/8"x3/4" and 3/4"	3/4" FIP	1.5
HHA31-344-NL	3/4"	1"	1" FIP	1.8
HHA32-323-NL	3/4"	5/8"x3/4" and 3/4"	3/4" Fl. Cop.	2.0
▶* HHA34-323-NL	3/4"	5/8"x3/4" and 3/4"	3/4" CTS P.J.	2.0

WITH METER YOKE INLET FOR IRON YOKE SETTINGS

CATALOG NUMBER	DESCRIPTION			APPROX. WT. LBS.
	VALVE SIZE	METER SIZE INLET	OUTLET SIZE & TYPE	
Δ HHA91-313-NL	3/4"	5/8"	3/4" FIP	1.5
Δ HHA91-323-NL	3/4"	5/8"x3/4" and 3/4"	3/4" FIP	1.4
Δ HHA91-344-NL	3/4"	1"	1" FIP	1.9
Δ HHA92-313-NL	3/4"	5/8"	3/4" Fl. Cop.	2.1
Δ HHA92-323-NL	3/4"	5/8"x3/4" and 3/4"	3/4" Fl. Cop.	2.0
▶* Δ HHA94-313-NL	3/4"	5/8"	3/4" CTS P.J.	2.0
▶*Δ HHA94-323-NL	3/4"	5/8"x3/4" and 3/4"	3/4" CTS P.J.	1.9
▶* HHA96-313-NL	3/4"	5/8"	3/4" P.J. for PE Pipe	2.0
▶* HHA96-323-NL	3/4"	5/8"x3/4" and 3/4"	3/4" P.J. for PE Pipe	2.0

Straight Cascading Dual Check Valves (in-line accessible) FEMALE IRON PIPE THREAD BOTH ENDS

CATALOG NUMBER	DESCRIPTION			LENGTH	APPROX. WT. LBS.
	VALVE SIZE	METER SIZE INLET	OUTLET SIZE		
HHS11-333-NL	3/4"	3/4"	3/4"	4-1/16"	1.5

WITH METER SWIVEL NUT INLET

CATALOG NUMBER	DESCRIPTION			APPROX. WT. LBS.
	VALVE SIZE	METER SIZE INLET	OUTLET SIZE & TYPE	
HHS31-313-NL	3/4"	5/8"	3/4" FIP	1.7
HHS31-323-NL	3/4"	5/8"x3/4" and 3/4"	3/4" FIP	1.8
HHS31-324-NL	3/4"	5/8"x3/4" and 3/4"	1" FIP	2.0
HHS31-344-NL	3/4"	1"	1" FIP	2.1
HHS38-323-NL	3/4"	5/8"x3/4" and 3/4"	3/4" MIP	1.7
HHS30-320-NL	3/4"	5/8"x3/4" and 3/4"	No.1 Male Kornerhorn Thread for Pack Joint Assemblies (see Catalog Section "B")	1.8

WITH METER YOKE INLET FOR IRON YOKE SETTINGS

CATALOG NUMBER	DESCRIPTION			APPROX. WT. LBS.
	VALVE SIZE	METER SIZE INLET	OUTLET SIZE & TYPE	
HHS91-313-NL	3/4"	5/8"	3/4" FIP	1.7
HHS91-323-NL	3/4"	5/8"x3/4" and 3/4"	3/4" FIP	1.7
HHS91-344-NL	3/4"	1"	1" FIP	2.2

Straight Dual Check Valves (in-line accessible) FEMALE IRON PIPE THREAD BOTH ENDS

CATALOG NUMBER	DESCRIPTION			LENGTH	APPROX. WT. LBS.
	VALVE SIZE	METER SIZE INLET	OUTLET SIZE		
HHS11-777-NL	2"	2"	2"	7-3/8"	8.0

Options Available

* **Grip Joint** for CTS and PEP can be ordered by adding "-G to the catalog number. Example: HHA34-323-G-NL.

♦ **Quick Joint** is available. Add "-Q" to the catalog number.

▶ **Ultra-Tite** compression is available. Add "-U-AWT" to the end of the catalog number. (Consists of components assembled watertight.)

Δ Indicates drain/test valve available. Add "D" to catalog number. Example: HHA31-323D-NL

3/4" Dual check valves are available with enhanced chlorine/chloramine resistant components. Add "CR" to the end of the alpha code. Example: HHACR31-313-NL

Ford Single Check Valves

On services where an approved backflow preventer is not desired or required, a Ford Single Check Valve may be installed. A single check valve deters hot water backflow from a water heater, which could damage the working parts of a water meter. They also keep water from the house plumbing from flowing into a meter pit or onto a basement floor when a meter is removed from service.

Ford Single Check Valves are available in in-line accessible angle and straight styles and in sizes from 3/4" through 2". They can be an integral part of a Ford Coppersetter, Customsetter or Iron Yoke. See Catalog Sections E, F and FA.

Angle Check Valves (in-line accessible)

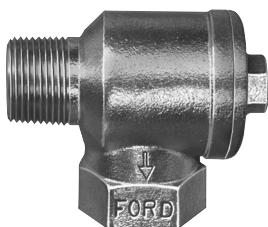

HA81-333-NL

MALE IRON PIPE THREAD INLET BY FEMALE IRON PIPE THREAD OUTLET

CATALOG NUMBER	DESCRIPTION			APPROX. Wt. Lbs.
	VALVE SIZE	INLET SIZE	OUTLET SIZE	
HA81-333-NL	3/4"	3/4"	3/4"	1.1

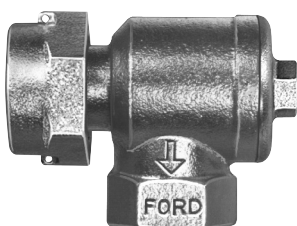

HA31-313-NL

METER SWIVEL NUT INLET BY FEMALE IRON PIPE THREAD OUTLET

CATALOG NUMBER	DESCRIPTION			APPROX. Wt. Lbs.
	VALVE SIZE	METER SIZE INLET	OUTLET SIZE	
Δ HA31-313-NL	3/4"	5/8"	3/4"	1.3
Δ HA31-323-NL	3/4"	5/8"x3/4" & 3/4"	3/4"	1.4
Δ HA31-444-NL	1"	1"	1"	1.7



HA32-313-NL

METER SWIVEL NUT INLET BY FLARE COPPER OUTLET

CATALOG NUMBER	DESCRIPTION			APPROX. Wt. Lbs.
	VALVE SIZE	METER SIZE INLET	OUTLET SIZE	
HA32-313-NL	3/4"	5/8"	3/4"	1.7
HA32-323-NL	3/4"	5/8"x3/4" & 3/4"	3/4"	1.8
HA32-444-NL	1"	1"	1"	2.3

METER SWIVEL NUT INLET BY PACK JOINT FOR COPPER OR PLASTIC TUBING (CTS)* OUTLET

CATALOG NUMBER	DESCRIPTION			APPROX. Wt. Lbs.
	VALVE SIZE	METER SIZE INLET	OUTLET SIZE	
▶ HA34-313-NL	3/4"	5/8"	3/4"	1.6
▶♦ HA34-323-NL	3/4"	5/8"x3/4" & 3/4"	3/4"	1.8
▶ HA34-324-Q-NL	3/4"	5/8"x3/4" & 3/4"	1" Q.J./CTS	1.8
▶♦ HA34-444-NL	1"	1"	1"	2.0

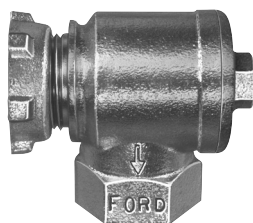

HA91-323-NL

METER YOKE INLET BY IRON YOKE SETTINGS

CATALOG NUMBER	DESCRIPTION			APPROX. Wt. Lbs.
	VALVE SIZE	METER SIZE INLET	OUTLET SIZE & TYPE	
Δ HA91-313-NL	3/4"	5/8"	3/4" FIP	1.4
Δ HA91-323-NL	3/4"	5/8"x3/4" & 3/4"	3/4" FIP	1.2
Δ HA91-444-NL	1"	1"	1" FIP	1.7
Δ HA92-313-NL	3/4"	5/8"	3/4" Fl. Cop.	1.7
Δ HA92-323-NL	3/4"	5/8"x3/4" & 3/4"	3/4" Fl. Cop.	1.6
▶*Δ HA94-313-NL	3/4"	5/8"	3/4" P.J./CTS	1.6
▶*Δ HA94-323-NL	3/4"	5/8"x3/4" & 3/4"	3/4" P.J./CTS	1.9
▶*Δ HA94-324-NL	3/4"	5/8"x3/4" & 3/4"	1" P.J./PEP	1.6
▶* HA96-313-NL	3/4"	5/8"	3/4" P.J./PEP	1.7
▶* HA96-323-NL	3/4"	5/8"x3/4" & 3/4"	3/4" P.J./PEP	1.6

Options Available

- * **Grip Joint** for CTS or PEP can be ordered by adding "-G" to the catalog number. Example: HA34-323-G-NL
- ♦ **Quick Joint** is available. Add "-Q" to the catalog number.
- ▶ **Ultra-Tite** compression is available. Add "-U-AWT" to the end of the catalog number. (Consists of components assembled watertight.)
- Δ Indicates drain/test valve available. Add "D" to catalog number. Example: HA31-323D-NL

Single Check Valves (continued)

Straight Check Valves (in-line accessible)

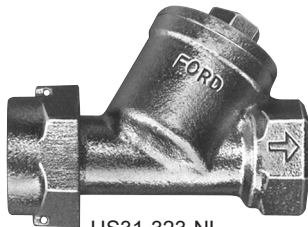

HS31-323-NL

METER SWIVEL NUT INLET BY FEMALE IRON PIPE THREAD OUTLET

CATALOG NUMBER	DESCRIPTION			APPROX. WT. LBS.
	VALVE SIZE	METER SIZE INLET	OUTLET SIZE	
HS31-313-NL	3/4"	5/8"	3/4"	1.2
Δ HS31-323-NL	3/4"	5/8"x3/4" & 3/4"	3/4"	1.4
Δ HS31-444-NL	1"	1"	1"	1.7



HS38-323-NL

METER SWIVEL NUT INLET BY MALE IRON PIPE THREAD OUTLET

CATALOG NUMBER	DESCRIPTION			APPROX. WT. LBS.
	VALVE SIZE	METER SIZE INLET	OUTLET SIZE	
Δ HS38-323-NL	3/4"	5/8"x3/4" & 3/4"	3/4"	1.3
HS38-444-NL	1"	1"	1"	1.6

METER SWIVEL NUT INLET BY FLARE COPPER OUTLET

CATALOG NUMBER	DESCRIPTION			APPROX. WT. LBS.
	VALVE SIZE	METER SIZE INLET	OUTLET SIZE	
HS32-323-NL	3/4"	5/8"x3/4" & 3/4"	3/4"	1.8



HS34-323-NL

METER SWIVEL NUT INLET BY PACK JOINT FOR COPPER OR PLASTIC TUBING (CTS)* OUTLET

CATALOG NUMBER	DESCRIPTION			APPROX. WT. LBS.
	VALVE SIZE	METER SIZE INLET	OUTLET SIZE	
▶ HS34-323-NL	3/4"	5/8"x3/4" & 3/4"	3/4"	1.6

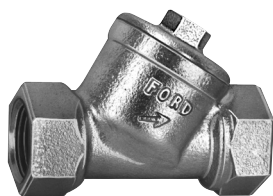

HS11-333-NL

FEMALE IRON PIPE THREAD INLET BY FEMALE IRON PIPE THREAD OUTLET

CATALOG NUMBER	DESCRIPTION			APPROX. WT. LBS.
	VALVE SIZE	INLET SIZE	OUTLET SIZE	
HS11-333-NL	3/4"	3/4"	3/4"	1.2
HS11-444-NL	1"	1"	1"	1.4
HS11-666-NL	1-1/2"	1-1/2"	1-1/2"	5.7
HS11-777-NL	2"	2"	2"	8.2

Options Available

* **Grip Joint** for CTS or PEP can be ordered by adding "-G" to the catalog number. Example: HS34-323-G-NL

▶ **Ultra-Tite** compression is available. Add "-U-AWT" to the catalog number. (Consists of components assembled watertight.)

Δ Indicates Drain/Test Valve available. Add "D" to catalog number. Example: HS31-323D-NL

Single Check Valves (continued)

Straight Check Valves (in-line accessible)

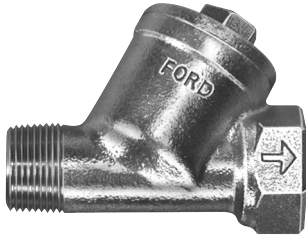

HS81-333-NL

MALE IRON PIPE THREAD INLET BY FEMALE IRON PIPE THREAD OUTLET

CATALOG NUMBER	DESCRIPTION			APPROX. Wt. LBS.
	VALVE SIZE	INLET SIZE	OUTLET SIZE	
HS81-333-NL	3/4"	3/4"	3/4"	1.2
HS81-444-NL	1"	1"	1"	1.4

MALE IRON PIPE THREAD INLET BY PACK JOINT FOR COPPER OR PLASTIC TUBING (CTS)* OUTLET

CATALOG NUMBER	DESCRIPTION			APPROX. Wt. LBS.
	VALVE SIZE	INLET SIZE	OUTLET SIZE	
▶ HS84-333-NL	3/4"	3/4"	3/4"	1.2



HS88-333-NL

MALE IRON PIPE THREAD BOTH ENDS

CATALOG NUMBER	DESCRIPTION			APPROX. Wt. LBS.
	VALVE SIZE	INLET SIZE	OUTLET SIZE & TYPE	
HS88-333-NL	3/4"	3/4"	3/4"	1.1

PACK JOINT FOR COPPER OR PLASTIC TUBING (CTS)* BOTH ENDS

CATALOG NUMBER	DESCRIPTION			APPROX. Wt. LBS.
	VALVE SIZE	INLET SIZE	OUTLET SIZE & TYPE	
▶ HS44-333-NL	3/4"	3/4"	3/4"	1.8

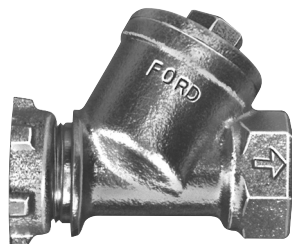

HS91-323-NL

METER YOKE INLET BY FEMALE IRON PIPE OUTLET

CATALOG NUMBER	DESCRIPTION			APPROX. Wt. LBS.
	VALVE SIZE	METER INLET SIZE	OUTLET SIZE & TYPE	
HS91-313-NL	3/4"	5/8"	3/4" FIP	1.3
HS91-323-NL	3/4"	5/8"x3/4" & 3/4"	3/4" FIP	1.3
HS91-344-NL	3/4"	1"	1" FIP	1.5
HS91-444-NL	1"	1"	1" FIP	1.7

Options Available

* **Grip Joint** for CTS or PEP can be ordered by adding "-G" to the catalog number. Example: HS34-323-G-NL

▶ **Ultra-Tite** compression is available. Add "-U-AWT" to the catalog number. (Consists of components assembled watertight.)

Ford Check Valves and Dual Check Valves

With Flanged Inlet for 1-1/2" and 2" Meters

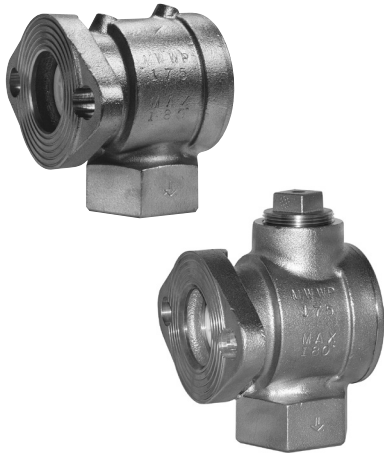

Angle Dual Check Valves (in-line accessible) ASSE Approved

METER FLANGE INLET BY FEMALE IRON PIPE THREAD OUTLET

CATALOG NUMBER	DESCRIPTION			APPROX. WT. LBS.
	VALVE SIZE	METER SIZE INLET	OUTLET SIZE	
HHFA31-777-NL	2"	1-1/2" and 2"	2"	8.4

A three-port bleeder valve configuration is available for the HHFA31-777-NL valve (catalog number HHFA31-777-3TV-NL). Contact the factory for availability.

METER FLANGE INLET BY FEMALE IRON PIPE THREAD OUTLET WITH INTEGRAL 1-1/2" FIP TEST PLUG

CATALOG NUMBER	DESCRIPTION			APPROX. WT. LBS.
	VALVE SIZE	METER SIZE INLET	OUTLET SIZE	
HHFA31-777-TP6-NL	2"	2"	2"	8.6

Pressure Drop Test - 2" HHFA Dual Check Valves

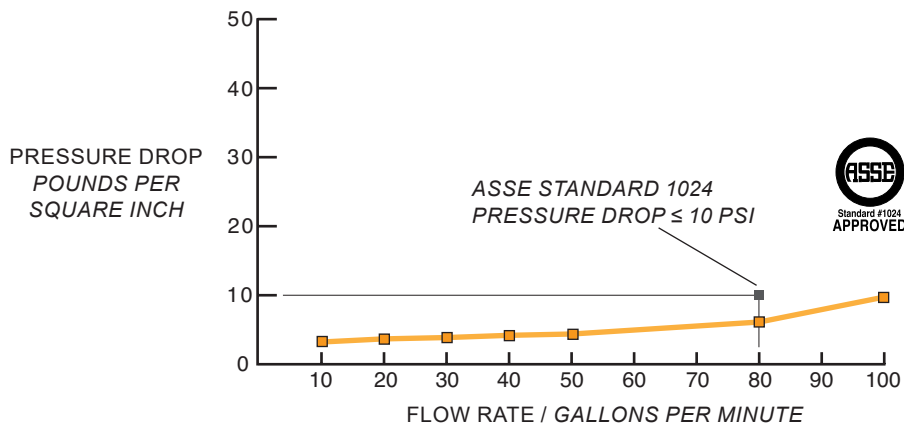

Angle Check Valves (in-line accessible)

METER FLANGE INLET BY FEMALE IRON PIPE THREAD

CATALOG NUMBER	DESCRIPTION			APPROX. WT. LBS.
	VALVE SIZE	METER SIZE INLET	OUTLET SIZE	
HFA31-666-NL	1-1/2"	1-1/2"	1-1/2"	6.6
HFA31-777-NL	2"	1-1/2" and 2"	2"	8.2

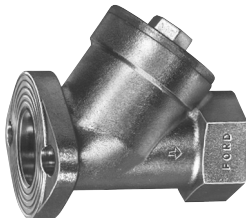

Straight Check Valves (in-line accessible)

METER FLANGE INLET BY FEMALE IRON PIPE THREAD OUTLET

CATALOG NUMBER	DESCRIPTION			LENGTH	APPROX. WT. LBS.
	VALVE SIZE	METER SIZE INLET	OUTLET SIZE		
HFS31-666-NL	1-1/2"	1-1/2"	1-1/2"	5-1/8"	6.9
HFS31-777-NL	2"	1-1/2" and 2"	2"	5-7/8"	8.4

Options Available

Meter Support Brackets to support meter during installation are available on 1-1/2" and 2" flanged valves at additional cost. Add "-MSB" to the catalog number. Example: HFA31-666-MSB-NL.

Check Valves for Kornerhorn Applications

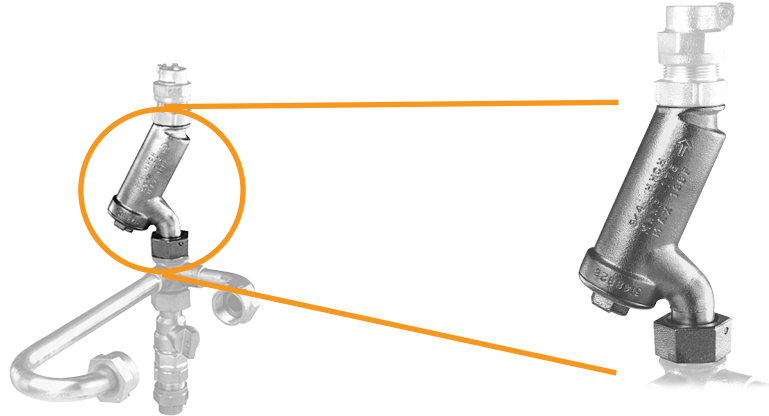

Straight Cartridge Style Dual Check Valve for Kornerhorn (in-line accessible)

FEMALE KORNERHORN THREAD SWIVEL NUT INLET BY MALE KORNERHORN THREAD OUTLET

CATALOG NUMBER	DESCRIPTION			APPROX. WT. LBS.
	VALVE SIZE	SIZE INLET & TYPE	OUTLET SIZE & TYPE	
* KH-HHCH-1-NL	3/4"	No. 1 Female Kornerhorn	No. 1 Male Kornerhorn	2.0
** KH-HHCH-1-D-NL	3/4"	No. 1 Female Kornerhorn	No. 1 Male Kornerhorn	2.1

* For pack joint assemblies for PET, PEP, PVC and iron pipe, refer to Catalog Section B.

** D indicates test/drain valve on top of access cap.

Cartridges are available with **enhanced chlorine/chloramine resistance**. Add "CR" to the end of the alpha code. Example: KH-HHCHCR-1-NL

Straight Cascading Dual Check Valve for Kornerhorn (in-line accessible)

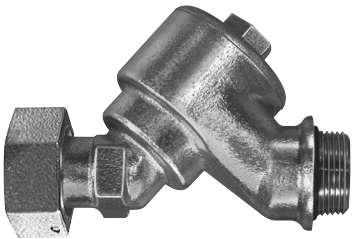

FEMALE KORNERHORN THREAD SWIVEL NUT INLET BY KORNERHORN THREAD OUTLET

CATALOG NUMBER	DESCRIPTION			APPROX. WT. LBS.
	VALVE SIZE	SIZE INLET & TYPE	OUTLET SIZE & TYPE	
* KHHCV-1-NL	3/4"	No. 1 Female Kornerhorn	No. 1 Male Kornerhorn	1.9

* For pack joint assemblies for PET, PEP, PVC and iron pipe, refer to Catalog Section B.

3/4" dual check valves are available with enhanced chlorine/chloramine resistant components. Add "CR" to the end of the alpha code. Example: KHHCVCR-1-NL

Straight Single Check Valve for Kornerhorn (in-line accessible)



FEMALE KORNERHORN THREAD INLET BY MALE KORNERHORN THREAD OUTLET

CATALOG NUMBER	DESCRIPTION			APPROX. WT. LBS.
	VALVE SIZE	SIZE INLET & TYPE	OUTLET SIZE & TYPE	
* KHCV-1-NL	3/4"	No. 1 Female Kornerhorn	No. 1 Male Kornerhorn	1.3

* For pack joint assemblies for PET, PEP, PVC and iron pipe, refer to Catalog Section B.

Check Valves for Special Applications

Straight Cartridge Style Dual Check Valve (not in-line accessible)



METER SWIVEL NUT INLET BY MALE KORNERHORN THREAD OUTLET

CATALOG NUMBER	DESCRIPTION			APPROX. WT. LBS.
	VALVE SIZE	SIZE INLET & TYPE	OUTLET SIZE & TYPE	
* HHC30-320-NL	3/4"	5/8"x3/4" and 3/4"	No. 1 Male Kornerhorn	1.6

* For pack joint assemblies for PET, PEP, PVC and iron pipe, refer to Catalog Section B.

Cartridges are available with **enhanced chlorine/chloramine resistance**. Add "CR" to the end of the alpha code. Example: HHCCR30-320-NL.

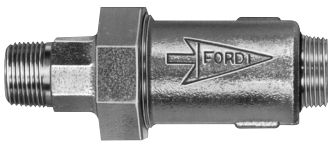

MALE IRON PIPE THREAD INLET BY MALE KORNERHORN THREAD OUTLET

CATALOG NUMBER	DESCRIPTION			APPROX. WT. LBS.
	VALVE SIZE	SIZE INLET & TYPE	OUTLET SIZE & TYPE	
* HHC80-330-NL	3/4"	3/4" Male Iron Pipe	No.1 Male Kornerhorn	1.6

* For pack joint assemblies for PET, PEP, PVC and iron pipe, refer to Catalog Section B.

Cartridges are available with **enhanced chlorine/chloramine resistance**. Add "CR" to the end of the alpha code. Example: HHCCR80-330-NL.

Straight Cut-In Check Valves — Single and Dual Checks (in-line accessible)



*HS00-300-NL Single Check Valve
Two removable PJA4-13-NL Pack Joint assemblies ordered separately

SINGLE CHECK VALVE FOR REMOVABLE PACK JOINT ASSEMBLIES

CATALOG NUMBER	DESCRIPTION			APPROX. WT. LBS.
	VALVE SIZE	SIZE INLET & TYPE	OUTLET SIZE & TYPE	
* HS00-300-NL	3/4"	No. 1 Male Kornerhorn	No. 1 Male Kornerhorn	1.2

* For pack joint assemblies for PET, PEP, PVC and iron pipe, refer to Catalog Section B.



*HHS00-300-NL Dual Check Valve
Two removable PJA4-13-NL Pack Joint assemblies ordered separately

CASCADING DUAL CHECK VALVE FOR REMOVABLE PACK JOINT ASSEMBLIES

CATALOG NUMBER	DESCRIPTION			APPROX. WT. LBS.
	VALVE SIZE	SIZE INLET & TYPE	OUTLET SIZE & TYPE	
* HHS00-300-NL	3/4"	No.1 Male Kornerhorn	No. 1 Male Kornerhorn	1.7

* For pack joint assemblies for PET, PEP, PVC and iron pipe, refer to Catalog Section B.

3/4" dual check valves are available with enhanced chlorine/chloramine resistant components. Add "CR" to the end of the alpha code. Example: HHSCR00-300-NL

Check Valve Replacement Kits

Internal Working Parts and Gaskets

Check valves are mechanical devices subject to fouling, wear and mineral deposits. Proper inspection and maintenance are critical for continued operation.

CATALOG NUMBER	DESCRIPTION
FOR SINGLE CHECKS	
HRK-3	3/4" and 1" HA, HS and 3/4" Kornerhorn Check Valve Replacement Kit
HRK-6	1-1/2" HS, HFA and HFS Replacement Kit for check valves with brass internal assemblies
*HRKP-67	1-1/2" and 2" HS, HFA and HFS Replacement Kit for check valves with plastic internal assemblies
HRK-7	2" HS, HFA and HFS Replacement Kit for check valves with brass internal assemblies
FOR DUAL CHECKS	
HHARK-1	5/8" HHA31-313-NL Dual Check Valve Replacement Kit
HHACRRK-1	3/4" Chloramine Resistant Cascading Angle Dual Check Replacement Kit for Valves with 5/8" Meter Connection
HHRK-3	3/4" and 3/4"x1" HHA, HHS and 3/4" Kornerhorn Dual Check Valve Replacement Kit
HHCRK-3	3/4" HHCA and HHC Cartridge Style Dual Check Valve Replacement Kit
HHCRRK-3	3/4" Chloramine Resistant Cascading Straight Dual Check Replacement Kit for Valves with 5/8" Meter Connection
HHCRRK-3	3/4" Chloramine Resistant Cascading Angle & Straight Dual Check Replacement Kit for Valves with 3/4"-1" Meter Connection
HHCCRK-3	3/4" HHCA and HHC Cartridge Style Dual Check Valve Enhanced Chlorine/Chloramine Resistant Replacement Kit
HHCRK-4	1" HHCA and HHC Cartridge Style Dual Check Valve Replacement Kit
HHCCRK-4	1" HHCA and HHC Cartridge Style Dual Check Valve Enhanced Chlorine/Chloramine Resistant Replacement Kit
HHRK-7	2" HHFA and HHS Dual Check Valve Replacement Kit
HHACR-3-CAP-NL	"CR" Stamped Cap Only for 3/4" Chloramine Resistant Cascading Angle Dual Check Valve with 5/8"-1" Meter Connections
HHCACR-3-CAP-NL	"CR" Stamped Cap Only for 3/4" Chloramine Resistant Cartridge Angle Dual Check Valve with 5/8"-1" Meter Connections
HHCACR-4-CAP-NL	"CR" Stamped Cap Only for 1" Chloramine Resistant Cartridge Angle Dual Check Valve with 1" Meter Connections

* For valves manufactured after May 2018

Ford Check Valves have the type of valve imprinted on the valve body.
Example: "HA", "HS", "HFA", "HFS", "HHA", "HHS", "HHC" or "HHCA"

Dual Cartridge Check Replacement Kit

Item	Description	Quantity
1	HHCA Access Cap O-Ring (Angle Style)	1
2	HHC Flat Gasket (Straight Style)	1
3	Check Valve Assembly	2
4	HHCA Plastic Cartridge Spacer	1

Dual Cascading Check Replacement Kit

Item	Description	Quantity
1	Access Cap O-Ring	1
2	Check Valve Assembly (4 separate items)	1
3	Rubber Damper	1

Ford Cut-in Check Valve Assemblies

For Retrofitting Angle Check Valve into Existing Ford Copper setters and Resetters

Ford Check Valves can be retrofitted on existing Ford setters without soldering, flaring or threading. By using one of three Pack Joint cut-in ells, practically every size and type of 5/8", 5/8"x3/4", and full 3/4" Ford Copper setter or Resetter, can be retrofitted with a check valve. The ell and check valve come as an assembled unit, ready to install on the setter.

To simplify installation, template drawings are available upon request to indicate the proper outlet leg cutting location for the check valve installation. The pictures below illustrate the proper cut-in procedure. A cut-in can be accomplished in just a few minutes with simple hand tools.

1. Mark

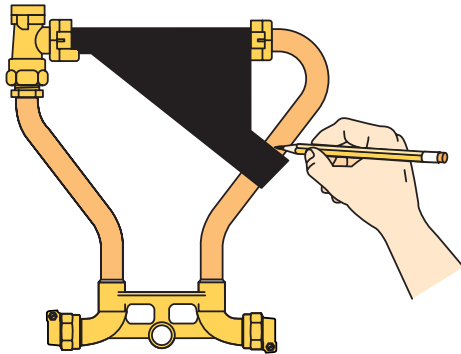

77°
HHL34-323-77-813-NL

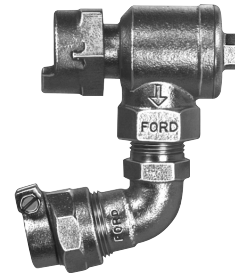

2. Cut

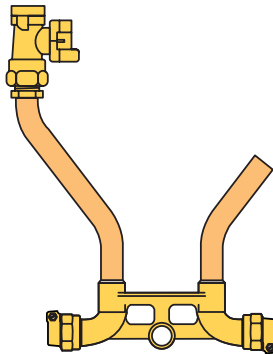

45°
HHL34-323-45-813-NL

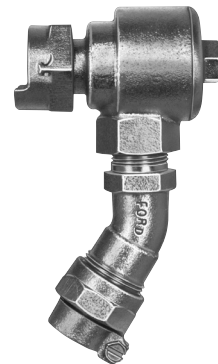

3. Install

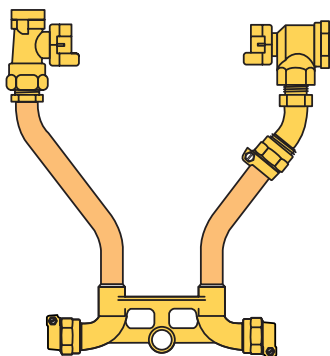

32°
HHL34-323-32-813-NL

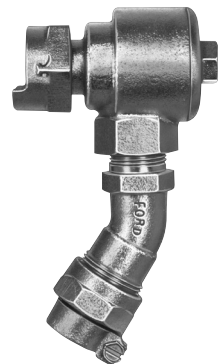

Ordering information for Cut-in Check Valve Assemblies

To insure proper fit, specify the size, style and height of the Ford setter you want to retrofit. For example, the 77 degree ell (**HHL34-323-77-813-NL**) is supplied for all 7" high setters. The 45 degree ell (**HHL34-323-45-813-NL**) fits all 9" high setters except in the 90 series, where it fits all heights. The 32 degree ell (**HHL34-323-32-813-NL**) is for all setters 12" or higher (except 90 series).

Note: Retrofit assemblies are available for single check valves and cascading dual check valves only. Cartridge dual checks are not available as a cut-in assembly.

Ford Cut-in Check Valve Assemblies

Cut-In Check Valve Assemblies for Ford Copper setters and Resetters (With "HA" Style Check Valves)

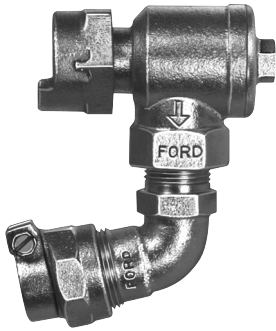

HL34-323-77-813-NL

CATALOG NUMBER	METER SIZE	SETTER HEIGHT
HL34-313-77-813-NL	5/8"	7"
HL34-313-45-813-NL	5/8"	9" & ALL 90 Series
HL34-313-32-813-NL	5/8"	12" and Higher
HL34-323-77-813-NL	5/8"x3/4"	7"
HL34-323-45-813-NL	5/8"x3/4"	9" & ALL 90 Series
HL34-323-32-813-NL	5/8"x3/4"	12" and Higher
HL34-444-68-NL	1"	90 Series only

Cut-In Dual Check Valve Assemblies for Ford Copper setters and Resetters (With "HHA" Style Dual Check Valves)



HHL34-323-32-813-NL

CATALOG NUMBER	METER SIZE	SETTER HEIGHT
HHL34-313-77-813-NL	5/8"	7"
HHL34-313-45-813-NL	5/8"	9" & ALL 90 Series
HHL34-313-32-813-NL	5/8"	12" and Higher
HHL34-323-77-813-NL	5/8"x3/4"	7"
HHL34-323-45-813-NL	5/8"x3/4"	9" & ALL 90 Series
HHL34-323-32-813-NL	5/8"x3/4"	12" and Higher
HHL34-344-68-NL	1"	90 Series only

3/4" dual check valves are available with enhanced chlorine/chloramine resistant components. Add "CR" to the end of the alpha code.
Example: HHL34-344-68-NL

Ford Retrosetters

The Convenient Way to Install Single or Dual Check Valves in Existing Meter Services!

Installing single or dual check valves in existing services can be inconvenient, involving plumbing work and expensive labor. In some situations, installation may be impossible due to existing meter setting space constraints. Ford Retrosetters eliminate most of these problems at a very reasonable cost.

Each style of Retrosetter is designed for a specific application and one of them should solve your particular check valve installation problem.

The Ford Resetter, available in Catalog Section F, is available with check valves. The Ford Resetter provides another method of installing check valves into existing meter services.

Style "B" Retrosetter - Designed for most retrosetting applications, the Style "B" Retrosetter positions the meter directly above the centerline of the service.

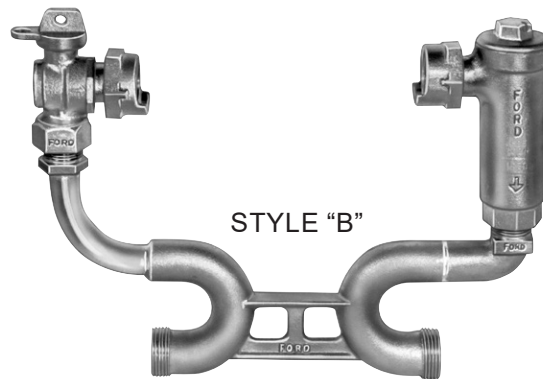

STYLE "B"

Approximate Height the Meter will be raised for style "B" Retrosetter

OUTLET VALVE TYPE	METER SIZE	METER RAISED APPROXIMATELY THIS AMOUNT
Single & Cascading Style	5/8", 5/8" x 3/4" & 3/4"	6"
Single & Cascading Style	1"	8-3/8"
Cartridge Style	5/8", 5/8" x 3/4" & 3/4"	7-1/4"
Cartridge Style	1"	8-3/8"
Cartridge Style	1" with 3/4"x1" check	8-1/8"

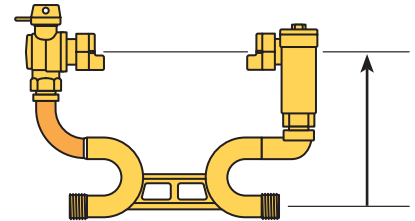

Style "C" Retrosetter - The Style "C" Retrosetter is designed for setting where space is very tight or where it is desirable to keep the height of the meter after resetting as shallow as possible. The Style "C" Retrosetter offsets the meter from the service line.

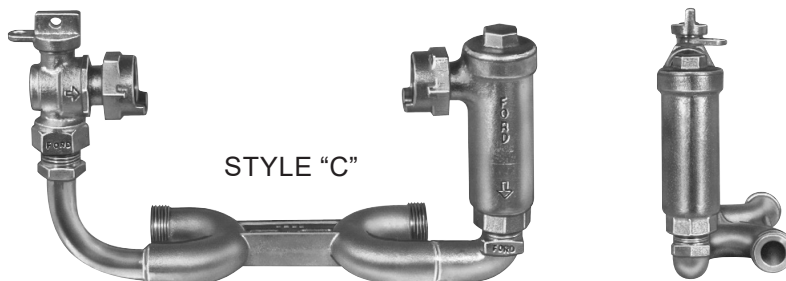

STYLE "C"

Approximate Height the Meter will be raised for style "C" Retrosetter

OUTLET VALVE TYPE	METER SIZE	METER RAISED APPROXIMATELY THIS AMOUNT	OFFSET
Single & Cascading Style	5/8", 5/8" x 3/4" & 3/4"	3-1/2"	2-1/2"
Single & Cascading Style	1"	5"	3-3/8"
Cartridge Style	5/8", 5/8" x 3/4" & 3/4"	4-3/4"	2-1/2"
Cartridge Style	1"	5"	3-3/8"
Cartridge Style	1" with 3/4"x1" check	4-7/8"	3-5/8"

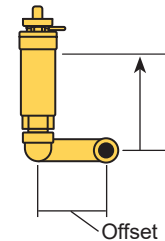

NOTE: Style "C" is available with a 60 degree offset, add "-60" to the catalog number

Ford "Z" Retrosetters are available for meter settings with greater space limitations. See page 25.

Ford Retrosetters

Quick and Easy Installation

All **Retrosetters** consist of a bottom bar, with inlet and outlet meter threads, which fits exactly into the space occupied by the meter. The meter is re-installed on top of copper arms with an attached swivel meter nut (or an angle ball valve or angle key valve with a meter nut) on the inlet and a single or dual check with a meter nut at the outlet. The entire installation takes only a few minutes (three steps) to complete.

Existing Meter Setting

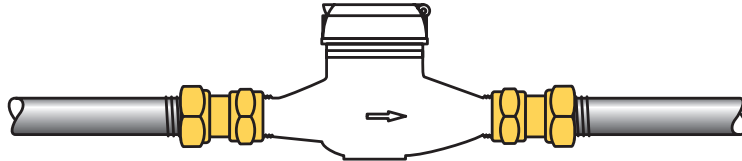

1. Remove Meter



2. Install Retrosetter

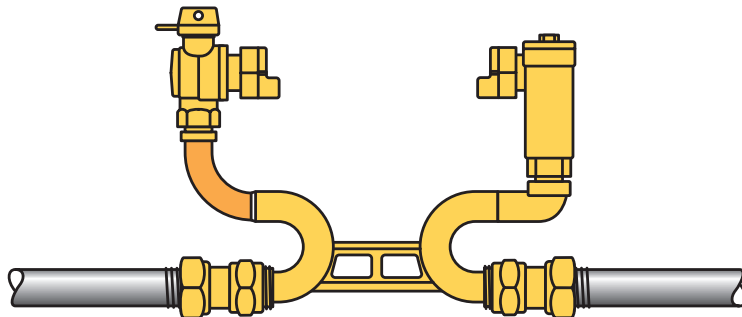

3. Reinstall Meter

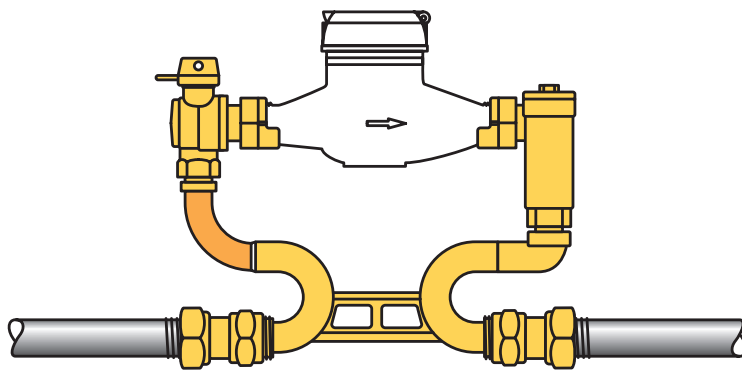

Four rubber meter gaskets are included, one for each swivel nut and two for the bottom bar.

Ford Retrosetters

Retrosetters have either an inlet key valve, inlet ball valve or no inlet valve. Outlet valve options include single check, dual check or cartridge dual check valve.

Retrosetter without Valves



RETROSETTERS WITHOUT VALVES

CATALOG NUMBER	METER SIZE	STYLE	APPROX. Wt. Lbs.
RETRO-1B-NL	5/8"	B	2.9
RETRO-1C-NL	5/8"	C	2.9
RETRO-2B-NL	5/8"x3/4"	B	3.2
RETRO-2C-NL	5/8"x3/4"	C	3.2
RETRO-3B-NL	3/4"	B	4.3
RETRO-3C-NL	3/4"	C	4.3
RETRO-4B-NL	1"	B	5.9
RETRO-4C-NL	1"	C	5.9

Retrosetter with No Inlet Valve



ANGLE SINGLE CHECK VALVE ON OUTLET

CATALOG NUMBER	METER SIZE	STYLE	APPROX. Wt. Lbs.
RETRO-1BH-NL	5/8"	B	3.9
RETRO-1CH-NL	5/8"	C	3.9
RETRO-2BH-NL	5/8"x3/4"	B	4.1
RETRO-2CH-NL	5/8"x3/4"	C	4.1
RETRO-3BH-NL	3/4"	B	5.0
RETRO-3CH-NL	3/4"	C	5.0
RETRO-4BH-NL	1"	B	7.1
RETRO-4CH-NL	1"	C	7.1

ANGLE DUAL CHECK VALVE ON OUTLET

CATALOG NUMBER	METER SIZE	STYLE	APPROX. Wt. Lbs.
RETRO-1BHH-NL	5/8"	B	4.1
RETRO-1CHH-NL	5/8"	C	4.1
RETRO-2BHH-NL	5/8"x3/4"	B	4.4
RETRO-2CHH-NL	5/8"x3/4"	C	4.4
RETRO-3BHH-NL	3/4"	B	4.5
RETRO-3CHH-NL	3/4"	C	4.5
RETRO-4B3HH-NL	1"	B	7.4
RETRO-4C3HH-NL	1"	C	7.4

ANGLE CARTRIDGE DUAL CHECK VALVE ON OUTLET

CATALOG NUMBER	METER SIZE	STYLE	APPROX. Wt. Lbs.
RETRO-1BHC-NL	5/8"	B	4.6
RETRO-1CHC-NL	5/8"	C	4.6
RETRO-2BHC-NL	5/8"x3/4"	B	4.8
RETRO-2CHC-NL	5/8"x3/4"	C	4.8
RETRO-3BHC-NL	3/4"	B	5.1
RETRO-3CHC-NL	3/4"	C	5.1
RETRO-4BHC-NL	1"	B	9.8
RETRO-4CHC-NL	1"	C	9.8

Cartridges are available with **enhanced chlorine/chloramine resistance**. Add "CR" to the end of the alpha code.

Example: RETRO-1BHCCR-NL

Ford Retrosetters (Continued)

Retrosetter with Angle Ball Valve on Inlet

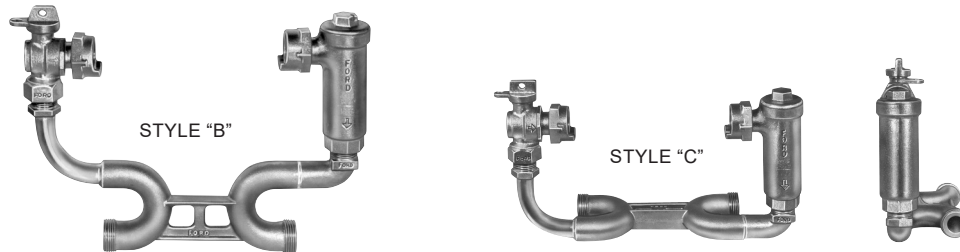

ANGLE BALL VALVE ON INLET AND ANGLE SINGLE CHECK VALVE ON OUTLET

CATALOG NUMBER	METER SIZE	STYLE	APPROX. Wt. LBS.
RETRO-1BVBH-NL	5/8"	B	4.8
RETRO-1CVBH-NL	5/8"	C	4.8
RETRO-2BVBH-NL	5/8"x3/4"	B	5.1
RETRO-2CVBH-NL	5/8"x3/4"	C	5.1
RETRO-3BVBH-NL	3/4"	B	6.1
RETRO-3CVBH-NL	3/4"	C	6.1
RETRO-4BVBH-NL	1"	B	9.1
RETRO-4CVBH-NL	1"	C	9.1

ANGLE BALL VALVE ON INLET AND ANGLE DUAL CHECK VALVE ON OUTLET

CATALOG NUMBER	METER SIZE	STYLE	APPROX. Wt. LBS.
RETRO-1BVBHH-NL	5/8"	B	5.1
RETRO-1CVBHH-NL	5/8"	C	5.1
RETRO-2BVBHH-NL	5/8"x3/4"	B	5.4
RETRO-2CVBHH-NL	5/8"x3/4"	C	5.4
RETRO-3BVBHH-NL	3/4"	B	5.4
RETRO-3CVBHH-NL	3/4"	C	5.4
RETRO-4BVB3HH-NL	1"	B	9.3
RETRO-4CVB3HH-NL	1"	C	9.3

ANGLE BALL VALVE INLET AND ANGLE CARTRIDGE DUAL CHECK VALVE OUTLET

CATALOG NUMBER	METER SIZE	STYLE	APPROX. Wt. LBS.
RETRO-1BVBHC-NL	5/8"	B	5.7
RETRO-1CVBHC-NL	5/8"	C	5.7
RETRO-2BVBHC-NL	5/8"x3/4"	B	5.9
RETRO-2CVBHC-NL	5/8"x3/4"	C	5.9
RETRO-3BVBHC-NL	3/4"	B	6.1
RETRO-3CVBHC-NL	3/4"	C	6.1
RETRO-4BVBHC-NL	1"	B	11.5
RETRO-4CVBHC-NL	1"	C	11.5

Cartridges are available with **enhanced chlorine/chloramine resistance**. Add "CR" to the end of the alpha code.

Example: RETRO-1BVBHCCR-NL

Ford Retrosetters (Continued)

Retrosetter with Angle Key Valve on Inlet

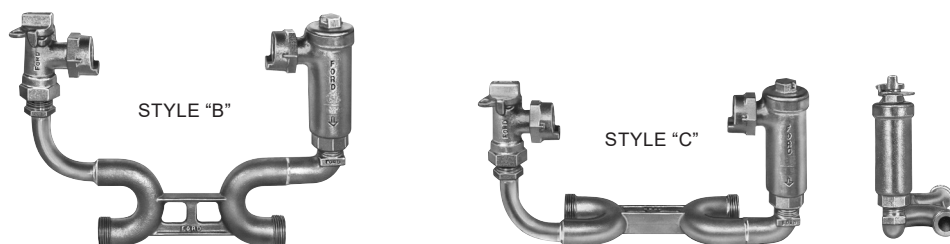

ANGLE KEY VALVE ON INLET AND ANGLE SINGLE CHECK VALVE ON OUTLET

CATALOG NUMBER	METER SIZE	STYLE	APPROX. WT. LBS.
RETRO-1BVH-NL	5/8"	B	4.7
RETRO-1CVH-NL	5/8"	C	4.7
RETRO-2BVH-NL	5/8"x3/4"	B	5.0
RETRO-2CVH-NL	5/8"x3/4"	C	5.0
RETRO-3BVH-NL	3/4"	B	5.4
RETRO-3CVH-NL	3/4"	C	5.4
RETRO-4BVH-NL	1"	B	8.6
RETRO-4CVH-NL	1"	C	8.6

ANGLE KEY VALVE ON INLET AND ANGLE DUAL CHECK VALVE ON OUTLET

CATALOG NUMBER	METER SIZE	STYLE	APPROX. WT. LBS.
RETRO-1BVHH-NL	5/8"	B	5.0
RETRO-1CVHH-NL	5/8"	C	5.0
RETRO-2BVHH-NL	5/8"x3/4"	B	5.3
RETRO-2CVHH-NL	5/8"x3/4"	C	5.3
RETRO-3BVHH-NL	3/4"	B	5.5
RETRO-3CVHH-NL	3/4"	C	5.5
RETRO-4BV3HH-NL	1"	B	8.8
RETRO-4CV3HH-NL	1"	C	8.8

ANGLE KEY VALVE ON INLET AND ANGLE CARTRIDGE DUAL CHECK VALVE ON OUTLET

CATALOG NUMBER	METER SIZE	STYLE	APPROX. WT. LBS.
RETRO-1BVHC-NL	5/8"	B	5.6
RETRO-1CVHC-NL	5/8"	C	5.6
RETRO-2BVHC-NL	5/8"x3/4"	B	5.8
RETRO-2CVHC-NL	5/8"x3/4"	C	5.8
RETRO-3BVHC-NL	3/4"	B	6.0
RETRO-3CVHC-NL	3/4"	C	6.0
RETRO-4BVHC-NL	1"	B	11.0
RETRO-4CVHC-NL	1"	C	11.0

Cartridges are available with **enhanced chlorine/chloramine resistance**. Add "CR" to the end of the alpha code.

Example: RETRO-1BVHCCR-NL

Ford "Z" Retrosetters

For Existing Meter Settings with Limited Spacing

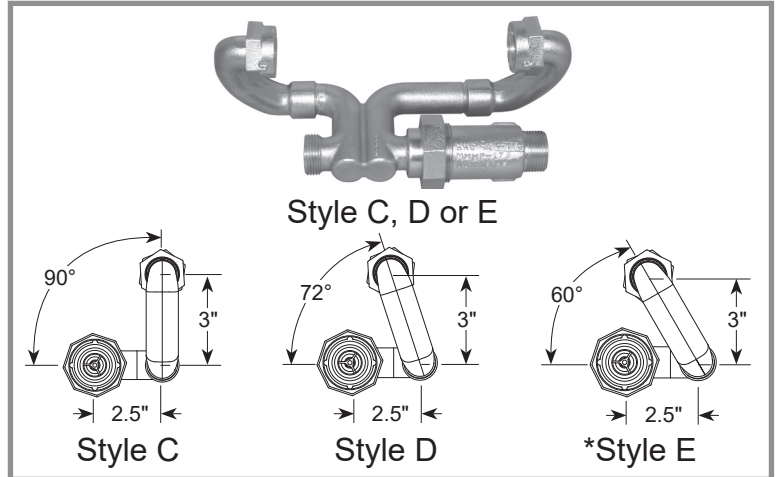
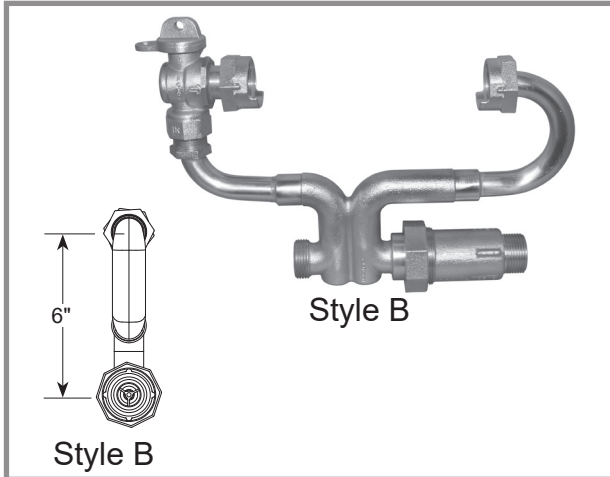

* Style E fits inside Ford Yokebox or equal if ordered without inlet and outlet valves.

STYLE

- B** = Meter directly above the centerline of the service
- C** = Meter is offset 90 degrees from the service line
- D** = Meter is offset 72 degrees from the service line
- E** = Meter is offset 60 degrees from the service line

TYPE FOR RETROSETTER

- Z** = Short bottom bar with optional dual check valve or adapter

OUTLET VALVE

- B** = Angle Ball Valve (padlock wing standard)
- V** = Angle Key Valve (padlock wing standard)
- H** = Angle Single Check Valve
- HH** = Angle Cascading Dual Check Valve
- HHACR** = Angle Cascading Dual Check Valve with Chlorine/Chloramine Resistant Components
- HC** = Angle Cartridge Style Dual Check Valve
- HHCR** = Angle Cartridge Style Dual Check Valve with Chlorine/Chloramine Resistant Cartridge
- Note:** Leave blank if outlet valve is not required

BOTTOM BAR OPTIONS

- A** = No Tap
- B** = 1/2" Inlet Tap - No Plug
- C** = 1/2" Inlet Tap - with Plug
- D** = 1/2" Outlet Tap - No Plug
- E** = 1/2" Outlet Tap - with Plug

SERVICE LINE CONNECTION

- A** = MM-33 (3/4" male meter threads)

RETRO-Z-2CBB-3-A-HCO-AFP-NL

METER SIZE
2 = 5/8" x 3/4"

INLET VALVE

- B** = Ball Valve (padlock wing standard)
- V** = Key Valve (padlock wing standard)

Note: Leave blank if inlet valve is not required

MINIMUM HEIGHT

- 3** = Approx. 3" high (style C, D & E only) (setter with HHCA angle dual check valve on outlet riser will be higher than 3")
- 6** = Approx. 6" high (style B only)

OUTLET BOTTOM BAR OPTIONS

- HCO** = Straight Cartridge Style Dual Check Valve (HHC) Outlet
- HCCRO** = Straight Cartridge Style Dual Check Valve with Enhanced Chlorine/Chloramine Resistance (HHCCR) Outlet
- AO** = Adapter Outlet
- Note:** Leave blank if option not required

NO-LEAD ALLOY ▲

FULL PORT (optional)

▲ Ford Meter Box no-lead brass products manufactured from UNS/CDA No. 89833 alloy shall contain no more than 0.25% total lead content by weight. United States federal and state laws allow the use of products manufactured from UNS C83600 85-5-5-5 brass alloy for only non-potable water systems within the United States.

Parties responsible for monitoring and maintaining proper water system design must exercise full responsibility in understanding and upholding the full intent and scope of applicable lead laws.

Ford Retrosetter Sampling Station

Features

- Converts an existing meter setting into a sampling station
 - Remove meter
 - Connect Retrosetter to existing meter nuts
 - Reinstall meter into Retrosetter
 - Ready for sampling
- Male quick disconnect assembly can be located on inlet or outlet
- Protective vinyl cover furnished with male quick disconnect
- Easy attachment of the 36" extension pipe with a female quick disconnect (extension pipe sold separately)
- Available in 5/8", 5/8"x3/4" and 1" meter sizes
- All Ford brass components coming in contact with potable water conform to AWWA C800 (ASTM B584, UNS C89833 no-lead brass alloy)
- Brass components **not** coming in contact with potable water conform to AWWA C800 (ASTM B62 and ASTM B584, UNS C83600, 85-5-5-5).

Quick Disconnect Cap To Retrofit Existing Angle Cartridge Dual Check

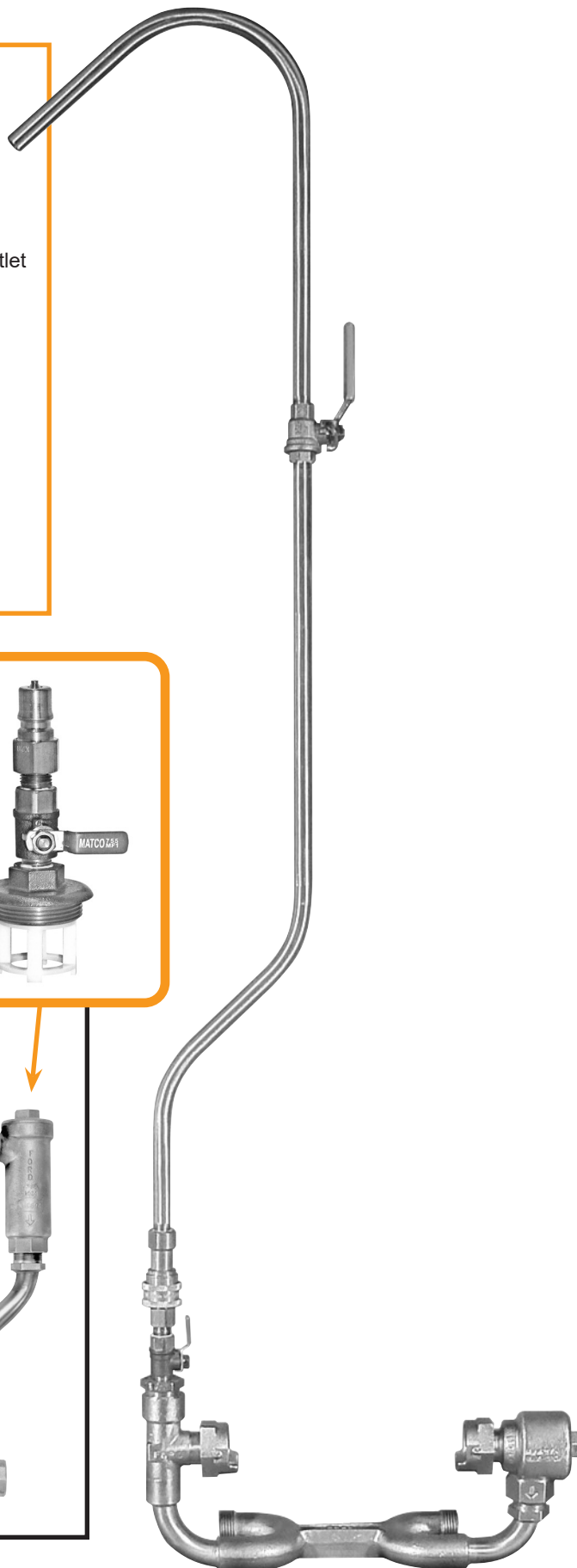
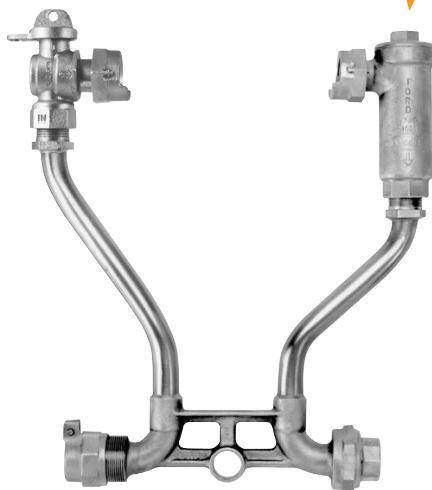
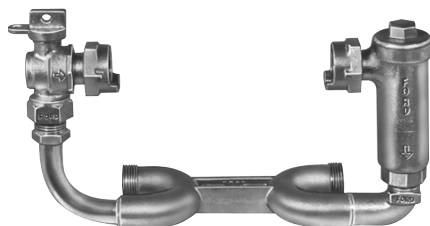

Ford Retrosetter Sampling Station

INLET - QUICK DISCONNECT OUTLET - METER NUT

CATALOG NUMBER	METER SIZE	STYLE	APPROX. HT.
RETRO-SS-1B-95190-051-NL	5/8"	B	12"
RETRO-SS-1C-95356-015-NL	5/8"	C	9-7/16"
RETRO-SS-2B-95356-016-NL	5/8" x 3/4"	B	12"
RETRO-SS-2C-95190-044-NL	5/8" x 3/4"	C	9-7/16"
♦	3/4"	B	-
RETRO-SS-3C-95190-049-NL	3/4"	C	12"
RETRO-SS-4B-95190-047-NL	1"	B	14-7/8"
RETRO-SS-4C-95190-046-NL	1"	C	11-1/2"

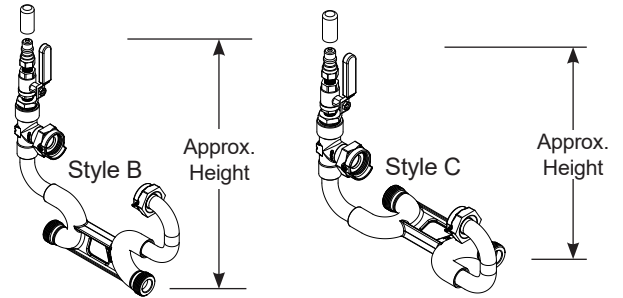

INLET - QUICK DISCONNECT OUTLET - ANGLE CASCADING DUAL CHECK VALVE

CATALOG NUMBER	METER SIZE	STYLE	APPROX. HT.
RETRO-SS-1BHH-95190-052NL	5/8"	B	12"
RETRO-SS-1C-95190-060-NL	5/8"	C	9-1/2"
RETRO-SS-2B-95190-045-NL	5/8" x 3/4"	B	12"
RETRO-SS-2C-95190-031-NL	5/8" x 3/4"	C	9-1/2"
♦	3/4"	B	-
♦	3/4"	C	-
♦	1"	B	-
*RETRO-SS-4C-95190-038-NL	1"	C	11-1/2"

* 1" angle cascading dual check valve contains 3/4" internal components.

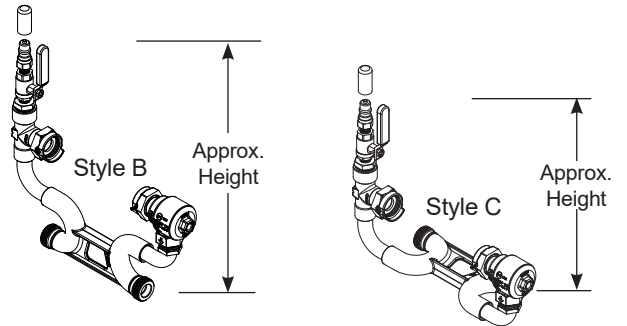

INLET - METER NUT OUTLET - ANGLE CARTRIDGE DUAL CHECK VALVE WITH QUICK DISCONNECT

CATALOG NUMBER	METER SIZE	STYLE	APPROX. HT.
RETRO-SS-1BHC-NL	5/8"	B	12-1/2"
RETRO-SS-1CHC-NL	5/8"	C	10-1/16"
RETRO-SS-2BHC-NL	5/8" x 3/4"	B	12-1/2"
RETRO-SS-2CHC-NL	5/8" x 3/4"	C	10-1/16"
RETRO-SS-3BHC-NL	3/4"	B	12-1/2"
RETRO-SS-3CHC-NL	3/4"	C	10-1/16"
RETRO-SS-4BHC-NL	1"	B	14"
RETRO-SS-4CHC-NL	1"	C	10-5/8"

♦ Contact factory for part number

Note: Brass extension pipe sold separately

Cartridges are available with enhanced chlorine/chloramine resistance. Add "CR" to the end of the alpha code.

Example: RETRO-SS-1CHCCR-NL

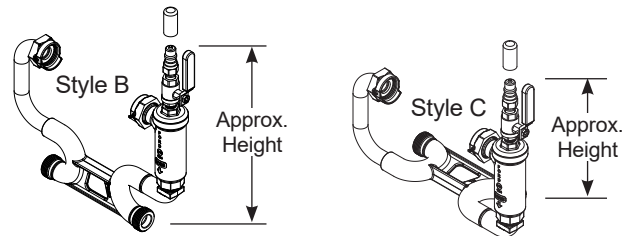

36" BRASS EXTENSION PIPES (SOLD SEPARATELY):

CATALOG NUMBER
SS-PIPE-95356-014-NL

CATALOG NUMBER
SS-PIPE-95356-005-NL

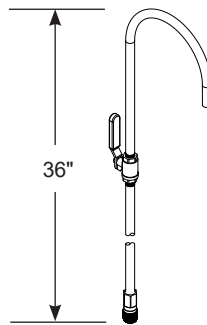
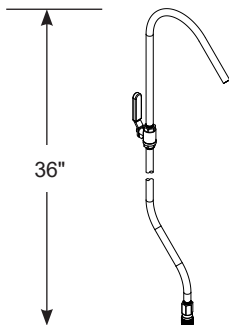

QUICK DISCONNECT CAP ONLY FOR HHCA STYLE DUAL CHECK VALVE

CATALOG NUMBER	SIZE
SS-CAP-3-NL	3/4"
SS-CAP-4-NL	1"

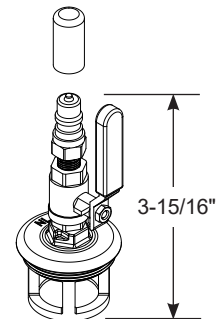

Section I

Ford[®] Check Valves, Retrosetters and Cut-in Check Valves

Warranty

All merchandise is warranted to be free from defects in material and factory workmanship for one year from date of shipment from our factory. We will provide, free of charge, new products in equal quantities for any that prove defective within one year from date of shipment from our factory. Manufacturer shall not be liable for any loss, damage, or injury, direct or consequential, arising out of the use of or the inability to use the product. Before using, user shall determine the suitability of the product for user's intended use and user assumes all risk and liability whatever in connection therewith. No claims for labor or consequential damage will be allowed. The foregoing may not be changed except by agreement signed by an officer of the manufacturer.

No other warranties are applicable or may be implied, including the implied warranty of merchantability and the implied warranty of fitness for particular purpose and any warranty relating to infringement or the like, all of which are disclaimed.

Please Note:

Consult the Ford Meter Box Company, Inc. website (www.fordmeterbox.com) for the most recent catalog information. The Ford Meter Box Company considers the information in this catalog to be correct at the time of publication. Items and option availability, including specifications, are subject to change without notice. Please verify that your product information is current.

