

## FEATURES & BENEFITS

### CONSTRUCTION

Unit is made of 18 gauge Type 304 stainless steel with a satin finish that resists stains and corrosion, and has soft, rounded corners. Unit features stainless steel satin finish back panel, vandal-resistant bottom plates, and 1-1/4" integral trap.

### FREEZE-RESISTANT VALVES

Fully engineered system with the pneumatic-operated, freeze-resistant valves mount in cabinets that are installed on the inside wall where room temperature does not drop below 50° F (10° C). After valve is operated, water left in supply line between valve and bubbler drains back into waste inside cabinet, protecting the unit from freezing, and allowing fountain to function year-round.

### MOUNTING

Included: In-wall 3/16" thick steel mounting plate adds extra wall support when mounting the fountains.

### BUBBLER HEADS

Polished chrome-plated brass bubbler heads with integral basin shank for added strength. Shielded, angled stream opening provides a steady, sanitary source of drinking water at .45 gpm.

### VANDAL-RESISTANT

The bubbler heads, push buttons, drain strainers and bottom plates are locked in place, discouraging unwanted vandal tampering.

## OPTIONS

- Freeze-Resistant Bottle Filler: Model 1920FR, freeze-resistant bottle filler can be a stand-alone wall mounted station, or mounted over the 1109FR & 1119FR series fountains.
- Cane Detection, Floor Mounted: Model SK6, floor mounted cane detection for the Haws Hi-Lo drinking fountains.

For more information, visit [www.hawsc.com](http://www.hawsc.com) or call (888) 640-4297.



Mounting Plate and Freeze Vales Included

## SPECIFICATIONS

Model 1119FRB vandal-resistant wall mounted freeze-resistant ADA drinking fountain shall include dual 18 gauge Type 304 Stainless Steel satin finish basins, In-wall 3/16" thick steel mounting plate adds extra wall support when mounting the fountains, polished chrome-plated brass vandal-resistant bubbler heads, polished chrome-plated brass push-buttons which operate pneumatic valves housed in insulated cabinets, installed on the inside wall where room temperatures do not drop below 50° F (10° C), self-draining water lines protect the unit from freezing, polished chrome-plated brass vandal-resistant waste strainers, stainless steel satin finish back panel, high and low fountain mounting levels, and 1-1/4" O.D. waste pipes.

## APPLICATIONS

Perfect for either public or private outdoor settings, Model 1119FRB is a great fit in areas where aesthetics are important to the overall appeal of the architecture. This series is precisely mounted, making it a nice addition to any surrounding. Beautiful satin finish helps to maintain the fountains overall appeal so it always remains looking as new as it did when it was installed. Specifically, this type of wall mounted drinking fountain may be placed in settings such as: parks, schools, and other facilities where the temperature may drop into freezing conditions. Model meets all current Federal Regulations for the disabled including those in the Americans with Disabilities Act. Haws manufactures drinking fountains, faucets and electric water coolers to be lead-free by all known definitions including NSF/ANSI/CAN 61- Section 9, NSF/ ANSI/CAN 372, California Proposition 65, and the Federal Safe Drinking Water Act. Product is compliant to California Health and Safety Code 116875 (AB 1953-2006), and 116876 (AB 100) "NSF/ANSI/CAN 61: Q ≤ 1".



# Models

## Model 1119FRB

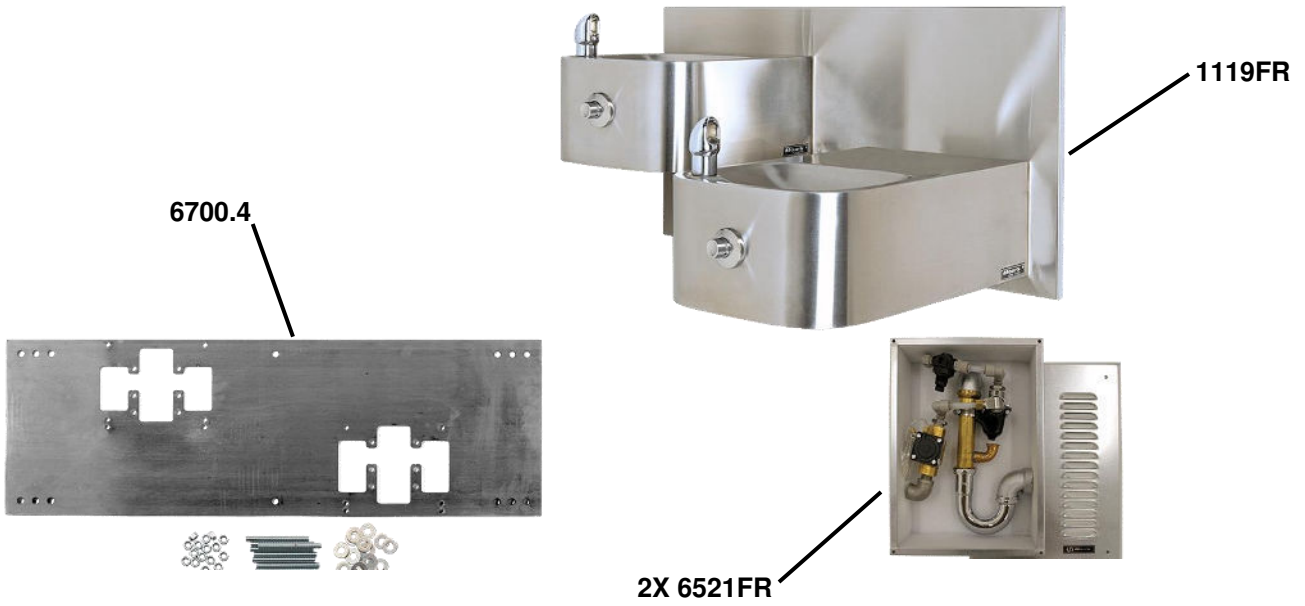

## Model 1119FRP

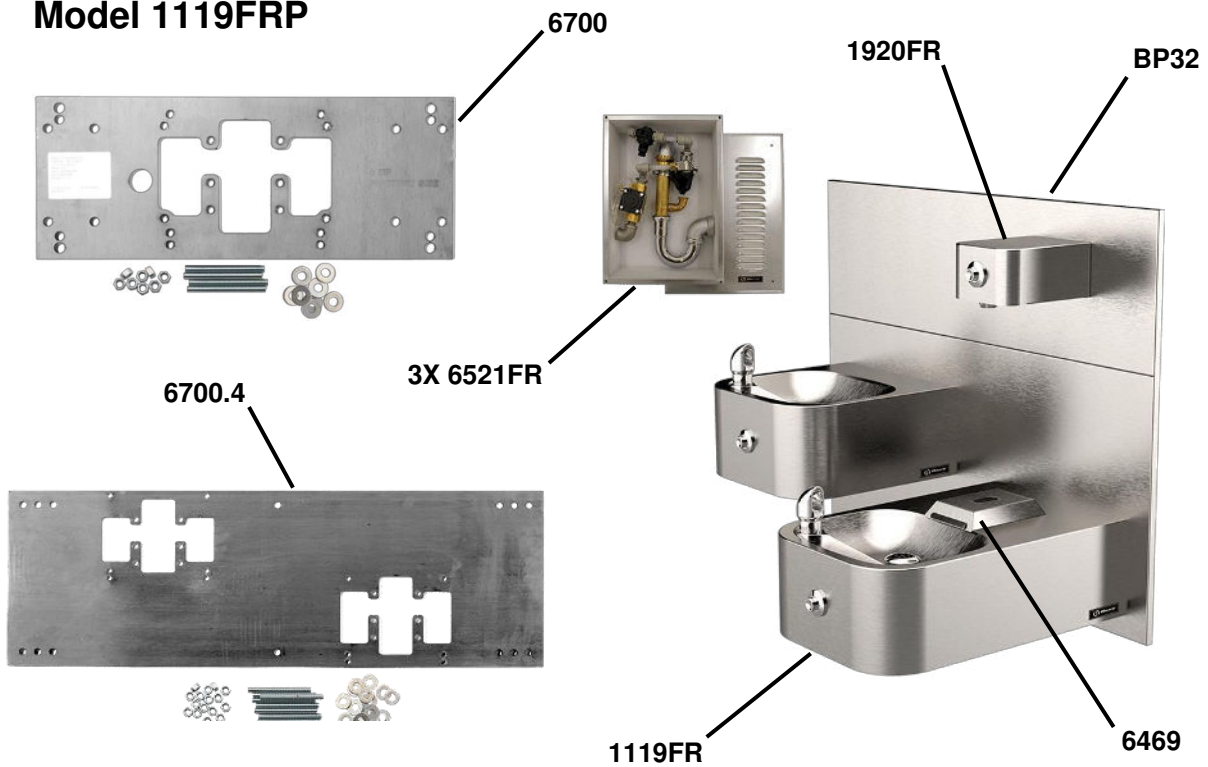

**SHOULD YOU EXPERIENCE DIFFICULTY WITH THE INSTALLATION OF THIS MODEL PLEASE CALL:**

**TECHNICAL SUPPORT: 1-800-766-5612**

**FOR CUSTOMER SERVICE: 1-888-640-4297**

**RECOMMENDED TOOLS:** Hack saw, pipe joint sealant, screwdriver, level, 12" adjustable wrench, 10" pipe wrench, 5/64", 3/32" and 5/32 " hex key wrench, 9/16", 1/2", 7/16" socket wrench or open-end wrench.

**LOCATION OF UNIT:** The Model 1119FR is a wheelchair accessible drinking water facility. The height dimensions shown meet current ADA requirements. When installing this unit, local, state or federal codes should be adhered to. If height other than shown is required, then dimensions must be adjusted accordingly.

**SUPPLY LINE:** The minimum recommended line size is 1/2" IPS with 30-90 psi (2-6 ATM) flowing pressure. Where sediment or mineral content is a problem, an inlet filter is recommended.

**PLUMBING CONNECTIONS:** Inlet valves are 1/2" NPT (F). Waste trap outlets are 1-1/4" NPT (F) (located on 6521FR Valve Boxes).

**MAINTENANCE:** Refer to Operation & Maintenance Manual of each model for information.

**PARTS LIST**

<b>FOR MODEL 1119FRB</b>	<b>QUANTITY</b>	<b>ITEMS INCLUDED</b>
1119FR	1	Drinking Fountain, Dual, L/Freeze Valves
6521FR	2	Valve. Freeze, Wall Mounted, W/Catcher
6700.4	1	Mounting Plate (includes Mounting Hardware for Bowls)
<b>FOR MODELS 1119FRP</b>	<b>QUANTITY</b>	<b>ITEMS INCLUDED</b>
1119FR	1	Drinking Fountain, Dual, L/Freeze Valves
6521FR	3	Valve. Freeze, Wall Mounted, W/Catcher
1920FR	1	Bottle Filler, Satin, Freeze Resistant
6700	1	Mounting Plate (includes Mounting Hardware for Bottle Filler Bracket)
6700.4	1	Mounting Plate (includes Mounting Hardware for Bowls)
6469	1	Strainer, 1920 Drip Tray
BP32	1	Back Panel for 1920

## **1119FRB/1119FRP INSTALLATION PROCEDURE**

**NOTE:** The product manuals included in this bundle contain images and directions for various models and configurations. Please note that not all images and configurations are relevant to this bundle.

**NOTE:** This bundle provides all necessary parts for installation, except for mounting hardware for the 6700.4 & 6700 Mounting Plates & 6469 Drip Tray (on 1119FRP model).

Use this manual as a reference for setting up this bundle. Follow the steps below to complete the installation of the 1119FRB or 1119FRP bundle.

### **STEP 1: Install Mounting Plate(s) (6700.4 & 6700)**

Locate and install the 6700.4 and/or 6700 Mounting Plate(s) (both models only include Mounting Hardware for Bowl/Bracket) using the installation instructions located in the 6700 and 6700.4 product boxes. 6700R Mounting Plate (optional) can be used if needed for 1920FR.

### **STEP 2: Install Drinking Fountain (1119FR) & Dual Back Panel (supplied)**

Locate and mount the fountain and dual Back Panel (supplied) on the wall using the installation instructions located in the 1119FR product box.

### **STEP 3: Install Bottle Filler Back Panel (BP32) & Bottle Filler (1920FR)**

*For Model 1119FRB, skip this step.*

Install the BP32 Back Panel and 1920FR bottle filler onto the 6700 (in-wall) Mounting Plate (supplied) or the 6700R (on-wall) Mounting Plate (optional). Use the installation instructions located in the BP32, 1920FR, and 6700 or 6700R product boxes.

### **STEP 4: Install Freeze Resistant In-Wall Valves (6521FR)**

Install the 6521FR Freeze Resistant In-Wall Valve (qty. 2 required on 1119FRB and qty. 3 required on 1119FRP) using the installation instructions located in the 6521FR product boxes.

### **STEP 5: Install Strainer 1920 Drip Tray (6469)**

*For model 1119FRP only.*

Attach the 6469 Strainer 1920 Drip Tray with an appropriate fastening method, using the installation instructions located in the 6469 product box.

*Refer to the troubleshooting guide within the appropriate product manual for any issues.*

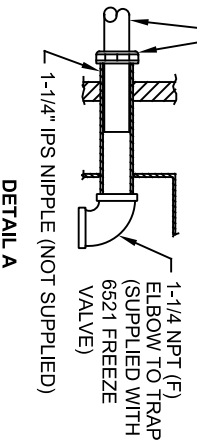
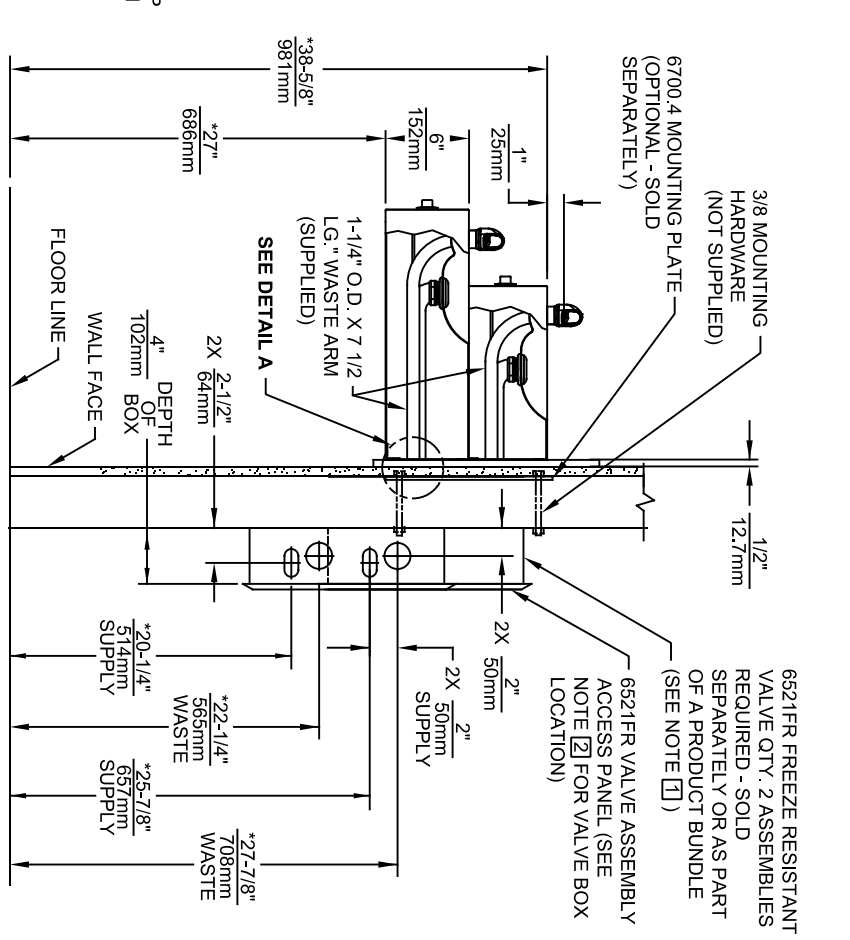
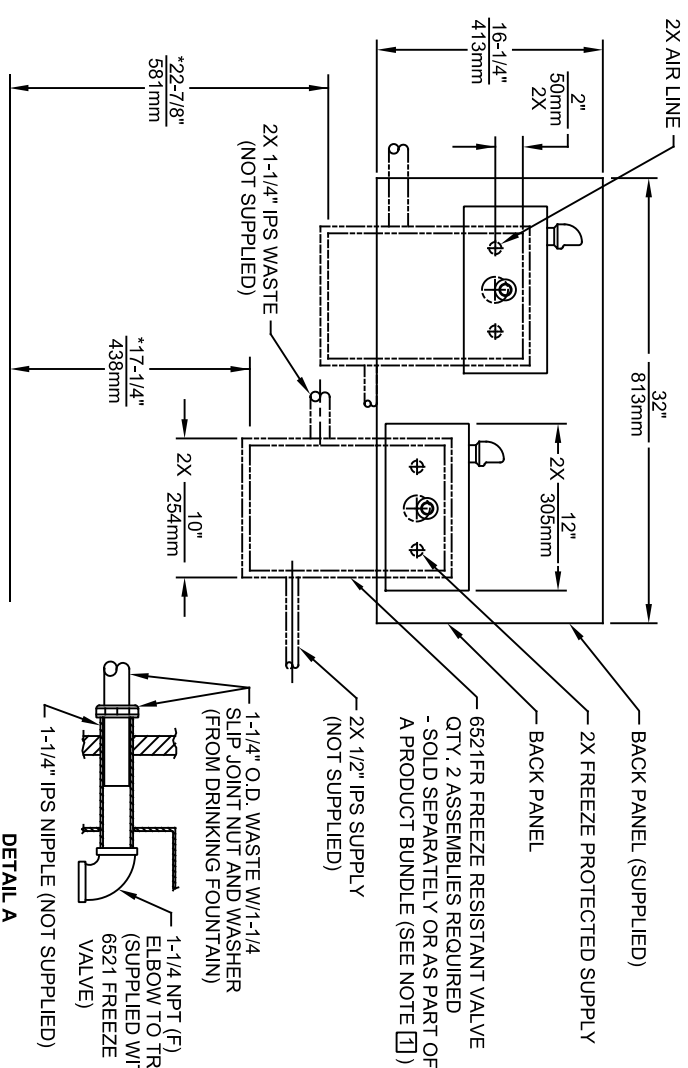
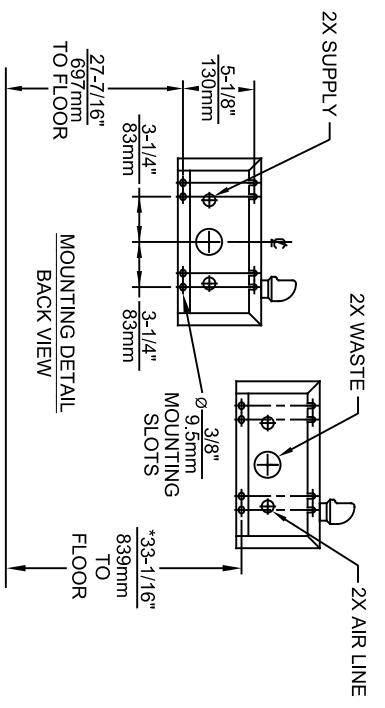
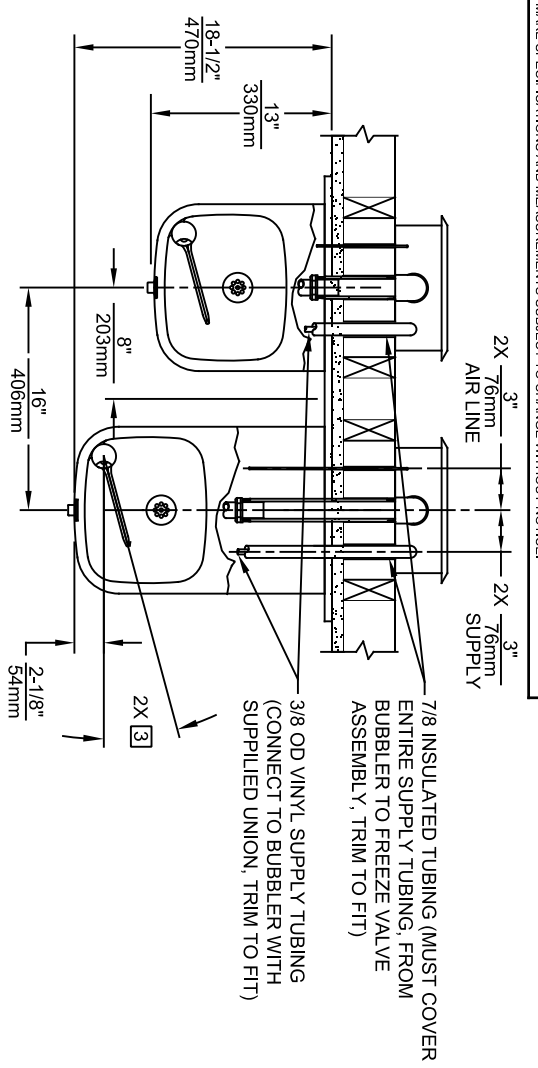

- NOTES:
- 1 PRODUCT BUNDLES AVAILABLE:  
 MODEL 1119FRB (QTY. 1 EACH 1119FR, 6700.4 & QTY. 2 EACH 6521FR),  
 MODEL 1119FRP (QTY. 1 EACH 1119FR, 6700.4, 6700, BP32\*, 1920FR\* &  
 6469\* (\*NOT SHOWN), & QTY. 3 EACH 6521FR). SEE 6521FR  
 INSTALLATION INSTRUCTIONS FOR CONNECTION DETAILS.
  - 2 VALVE ASSEMBLY MUST BE INSTALLED IN A  
 WARM AREA. PROVISIONS SHOULD BE MADE  
 TO ALLOW ACCESS TO ACCESS PANEL
  - 3 MAXIMUM ADJUSTABLE RANGE IS 15° FROM  
 PARALLEL TO BACK OF WALL.
  - 4. HOLD ROUGH-IN DIMENSIONS ± 1/4" (6.4mm).
  - 5. \* WHEN INSTALLING THIS UNIT LOCAL, STATE  
 OR FEDERAL CODES SHOULD BE ADHERED  
 TO. FOR INSTALLATION HEIGHTS OTHER  
 THAN SHOWN, DIMENSIONS MARKED (\*)  
 MUST BE ADJUSTED ACCORDINGLY.



**Haws**  
Since 1906

ECON. NO. REVISED PER BY:	MODEL(S)	SCALE:	DRAWING TYPE:
1119FRB	1119FR	1:14.5	INSTALLATION
DATE: 6/10/98	DATE: 10/17/24	SHEET:	1 OF 1
CHKD: KM	REVISED:	REVISION: 16	

1456 KLEPPE LANE  
 SPARKS, NEVADA, 89431  
 (775) 359-4712 FAX (775) 359-7424  
 E-MAIL: HAWS@HAWS.CO.COM  
 WEBSITE: WWW.HAWS.CO.COM