

# Installation, Operating and Service Instructions for

# AP-U™

- Natural Draft
- Oil-Fired
- Water Boiler
- B20 Ready

### Models:

- AP-110U-N
- AP-110U-T
- AP-154U-N
- AP-154U-T



<u>Manual Contents</u>	<u>Page</u>
1. General Information .....	5
2. Pre-Installation .....	6
3. Water Piping and Trim .....	9
4. Venting .....	14
5. Electrical .....	16
6. Oil Piping .....	19
7. System Start-Up .....	21
8. Operating .....	27
9. Maintenance & Service Instructions .....	31
10. Boiler Cleaning .....	32
11. Troubleshooting .....	35
12. Service Parts .....	40

### TO THE INSTALLER:

Affix these instructions adjacent to boiler.

### TO THE CONSUMER:

Retain these instructions for future reference.

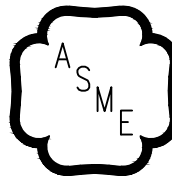

H

For service or repairs to boiler, call your heating contractor. When seeking information on boiler, provide Boiler Model Number and Serial Number as shown on Rating Label.



**IMPORTANT INFORMATION - READ CAREFULLY**

**All boilers must be installed in accordance with National, State and Local Plumbing, Heating and Electrical Codes and the regulations of the serving utilities. These Codes and Regulations may differ from this instruction manual. Authorities having jurisdiction should be consulted before installations are made.**

**In all cases, reference should be made to the following Standards:**

**USA BOILERS**

- A. Current Edition of American National Standard ANSI/NFPA 31, “Installation of Oil Burning Equipment”; for recommended installation practices.**
- B. Current Edition of American National Standard ANSI/NFPA 211, “Chimneys, Fire places, Vents, and Solid Fuel Burning Appliances”, For Venting requirements.**
- C. Current Edition of American Society of Mechanical Engineers ASME CSD-1, “Controls and Safety Devices for Automatically Fired Boilers”, for assembly and operations of controls and safety devices.**
- D. All wiring on boilers installed in the USA shall be made in accordance with the National Electrical Code and/or Local Regulations.**

**IMPORTANT**

This boiler is equipped with a feature that saves energy by reducing the boiler water temperature as the heating load decreases. This feature is equipped with an override which is provided primarily to prevent the use of external energy management system that serves the same function. THIS OVERRIDE MUST NOT BE USED UNLESS AT LEAST ONE OF THE FOLLOWING CONDITIONS IS TRUE:

- An external energy management system is installed that reduces the boiler water temperature as the heating load decreases.
- This boiler is not used for any space heating.
- This boiler is part of a modular or multiple boiler system having a total input of 300,000 BTU/HR or greater.
- This boiler is equipped with a tankless coil.

** DANGER**

**Indicates an imminently hazardous situation** which, if not avoided, will result in death, serious injury or substantial property damage.

** CAUTION**

**Indicates a potentially hazardous situation** which, if not avoided, may result in moderate or minor injury or property damage.

** WARNING**

**Indicates a potentially hazardous situation** which, if not avoided, may result in moderate or minor injury or property damage.

**NOTICE:** Indicates special instructions on installation, operation, or maintenance which are important but not related to personal injury hazards.

**NOTICE** This boiler has a limited warranty, a copy of which is included with this boiler. The warranty for this boiler is valid only if the boiler has been installed, maintained and operated in accordance with these instructions.

Surface rust on cast iron sections may be attributed to the manufacturing process as well as condensation during storage. Surface rust is normal and does not affect the performance or longevity of a boiler.

**⚠ DANGER**

DO NOT store or use gasoline or other flammable vapors or liquids in the vicinity of this or any other appliance.

**⚠ WARNING**

Improper installation, adjustment, alteration, service or maintenance can cause property damage, personal injury or loss of life. Failure to follow all instructions in the proper order can cause personal injury or death. Read and understand all instructions, including all those contained in component manufacturers manuals which are provided with the boiler before installing, starting-up, operating, maintaining or servicing this boiler. Keep this manual and literature in legible condition and posted near boiler for reference by owner and service technician.

- This boiler requires regular maintenance and service to operate safely. Follow the instructions contained in this manual.
- Installation, maintenance, and service must be performed only by an experienced, skilled and knowledgeable installer or service agency.
- All heating systems should be designed by competent contractors and only persons knowledgeable in the layout and installation of hydronic heating systems should attempt installation of any boiler.
- Installation is NOT complete unless a pressure relief valve is installed into the tapping located on top of Shell Assembly in the front left corner - See Water Piping and Trim Section of this manual for additional details.
- It is the responsibility of the installing contractor to see that all controls are correctly installed and are operating properly when installation is complete including verifying that the limit sensor is fully installed (seated in bottom of Well).
- Failure to properly install Limit Sensor may result in property damage, personal injury or loss of life due to elevated operating temperatures and/or pressures.
- This boiler is NOT suitable for installation on combustible flooring. DO NOT operate boiler on combustible flooring without factory supplied floor shield (available option at extra cost). A concrete pad is NOT sufficient to protect combustible flooring. Concrete over wood joists is considered combustible flooring.
- DO NOT install boiler on carpeting.
- When boiler is installed on concrete which is over a material that is subject to melting (PVC, PEX radiant tubing, etc.) a combustible floor shield must be used.
- DO NOT operate on masonry floors, which may contain moisture.
- DO NOT tamper with or alter the boiler or controls.
- Retain your contractor or a competent serviceman to assure that the unit is properly adjusted and maintained.
- Have Firetubes cleaned at least once a year - preferably at the start of the heating season to remove soot and scale. The inside of combustion chamber should also be cleaned and inspected at the same time.
- When cleaning this boiler, DO NOT damage combustion chamber. If damaged, combustion chamber must be replaced immediately.
- Oil Burner and Controls must be checked at least once a year or as may be necessitated.
- DO NOT operate boiler with jumpered or absent controls or safety devices.
- DO NOT operate boiler if any control, switch, component, or device has been subject to water.
- Boiler materials of construction, products of combustion and the fuel contain alumina, silica, heavy metals, carbon monoxide, nitrogen oxides, aldehydes and/or other toxic or harmful substances which can cause death or serious injury and which are known to the state of California to cause cancer, birth defects and other reproductive harm. Always use proper safety clothing, respirators and equipment when servicing or working nearby the boiler.

 **WARNING**

This boiler contains very hot water under 12 - 15 PSI pressure. DO NOT unscrew any pipe fittings nor attempt to disconnect any components of this boiler without positively assuring the water is cool and has no pressure. Always wear protective clothing and equipment when installing, starting up or servicing this boiler to prevent scald injuries. DO NOT rely on the pressure and temperature gauges to determine the temperature and pressure of the boiler. This boiler contains components which become very hot when the boiler is operating. DO NOT touch any components unless they are cool.

- High water temperatures increase the risk of scalding injury. If this boiler is equipped with a tankless heater for domestic water supply, a flow regulator and automatic mixing valve must be installed properly in tankless heater piping. See Piping and Trim Sections of this manual for details.
- This boiler needs fresh air for safe operation and must be installed so there are provisions for adequate combustion and ventilation air.
- This boiler must be connected to an approved chimney or vent system in good condition. Serious property damage could result if the boiler is connected to a dirty or inadequate chimney or vent system. The interior of the chimney flue must be inspected and cleaned before the start of the heating season for any obstructions. A clean and unobstructed chimney flue is necessary to allow noxious fumes that could cause injury or loss of life to vent safely and will contribute toward maintaining the boiler's efficiency. DO NOT operate boiler with the absence of an approved vent system.
- This boiler is supplied with controls which may cause the boiler to shut down and not re-start without service. If damage due to frozen pipes is a possibility, the heating system should not be left unattended in cold weather; or appropriate safeguards and alarms should be installed on the heating system to prevent damage if the boiler is inoperative.
- This boiler is designed to burn No. 2 fuel oil including bio blends not exceeding 20% Bio Diesel (ASTM D396) only.
  - DO NOT USE with Flammable Liquids, Gasoline, Crankcase drainings, charcoal lighter fluid, or any oil containing gasoline.
  - DO NOT convert to any solid fuel (i.e., wood, coal).
  - DO NOT convert to any gaseous fuel (i.e., natural gas, LP).
  - DO NOT USE Raw Vegetable Oil (RVO) or any fuel blended with RVO
  - Use of untested/uncertified fuels could result in explosion, fire, personal injury, or death, and/or damage to equipment and property.
  - Never burn garbage or paper in this boiler.
- All flammable debris, rags, paper, woodscraps, etc., should be kept clear of the boiler at all times. Keep the boiler area clean and free of fire hazards.

# 1 General Information

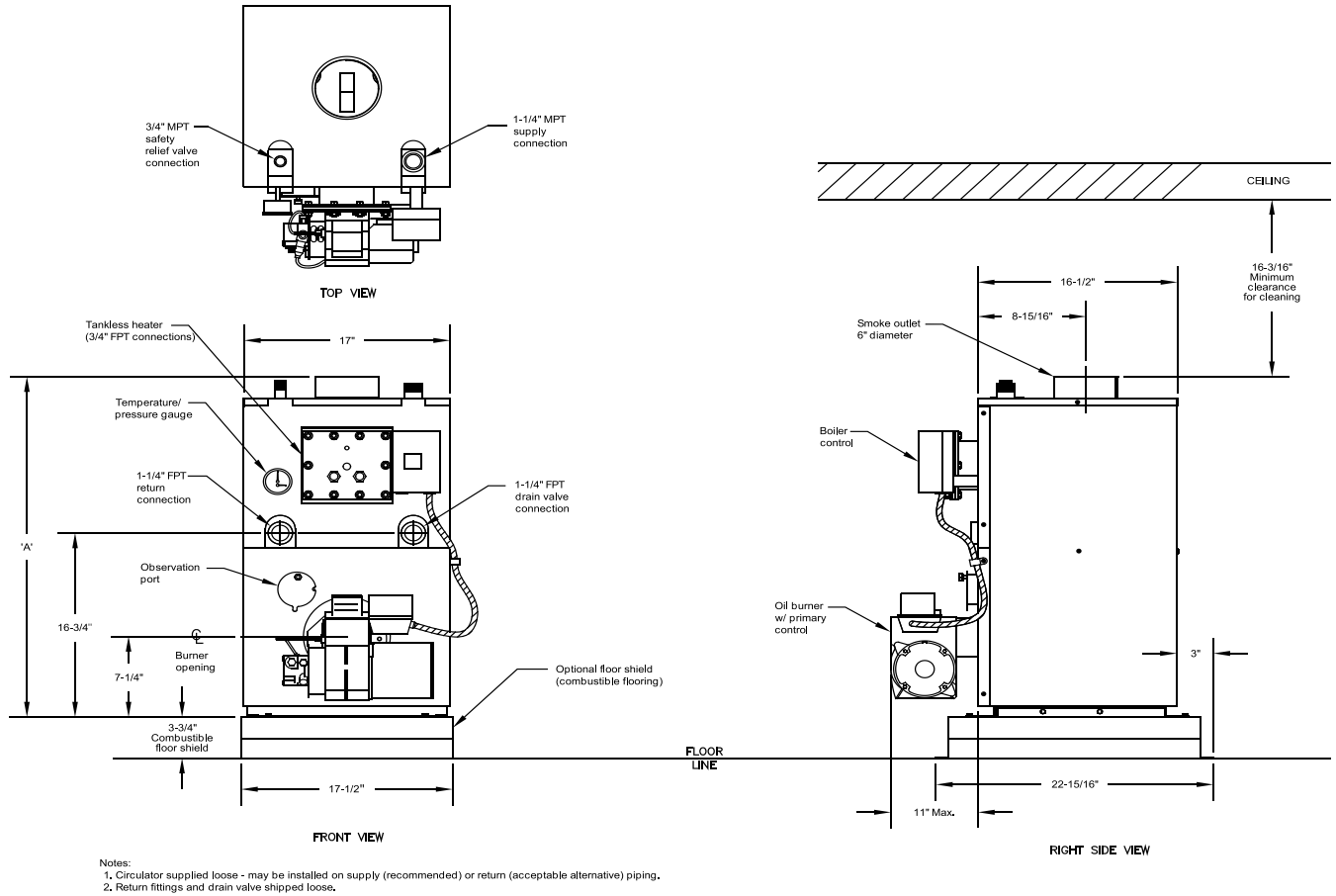

**Figure 1-1: AP-U Series Boiler Dimensional Data**

**Table 1-2: Dimensional D (See Figure 1-1)**

Boiler Model Number	Dimension 'A'	Water Capacity (gallons)	Approx. Shipping Weight (lb.)
AP-110U-N(T)	34-9/16	10.1	300
AP-154U-N(T)	41"	15.4	355

Note: Maximum Working Pressure: Water 30 PSI shipped standard.

**Table 1-3: Rating Data**

Boiler Model No.	Burner Capacity		DOE Heating Capacity - MBH (2)	AHRI NET Ratings - MBH (3)	AFUE %	Minimum Chimney Requirements		
	GPH	MBH (1)				Round In. Dia.	Rectangle In. x In.	Height Ft.
AP-110U-N(T)	0.75	110	95	83	86.2	6	8 x 8	15
AP-154U-N(T)	1.10	154	134	117	86.0	6	8 x 8	15

(1) MBH refers to thousands of BTU per hour

(2) Based on Standard Test prescribed by the United States Department of Energy at combustion conditions of 13.0% CO<sub>2</sub>

(3) Net AHRI rating based on a piping and pickup allowance of 1.15.

Note: The rating shown are based on the use of #2 Heating Oil.

## 2 Pre-Installation

- A. **INSPECT SHIPMENT** carefully for any signs of damage.
- All equipment is carefully manufactured, inspected and packed. Our responsibility ceases upon delivery of crated boiler to the carrier in good condition.
  - Any claims for damage or shortage in shipment must be filed immediately against the carrier by the consignee. No claims for variances from, or shortage in orders, will be allowed by the manufacturer unless presented within sixty (60) days after receipt of goods.
- B. **LOCATE BOILER** near final position before removing crate. See Figure 1-1. Using hand truck or pipe rollers under skid, move boiler into position along side installation site.

### CAUTION

**DO NOT** drop boiler. **DO NOT** bump boiler jacket against floor.

- LOCATE** so that vent pipe connection to chimney will be short and direct.
- BOILER IS NOT SUITABLE FOR INSTALLATION ON COMBUSTIBLE FLOOR** without factory supplied floor shield (available option at extra cost), see Page 9 for additional details. A Combustible Floor Shield can also

be constructed in accordance with NFPA 31. **DO NOT** install boiler on carpeting.

- FOR BASEMENT INSTALLATION**, provide a solid elevated base, such as concrete, if floor is not level, or if water may be encountered on floor around boiler.

### WARNING

**DO NOT** support boiler by placing blocks at the four (4) corners of the boiler.

Boiler base must be evenly supported under entire base.

Concrete over wood joists is considered combustible flooring. **DO NOT** operate on masonry floors, which may contain moisture.

- PROVIDE SERVICE CLEARANCE** of at least 48" clearance from front jacket panel for servicing burner and removal of front tankless heater.
- For minimum clearances to combustible materials. See Figure 2-1.

**NOTICE:** Clearance to venting is for single wall vent pipe. If Type L vent is used, clearance may be reduced to the minimum required by the vent pipe manufacturer.

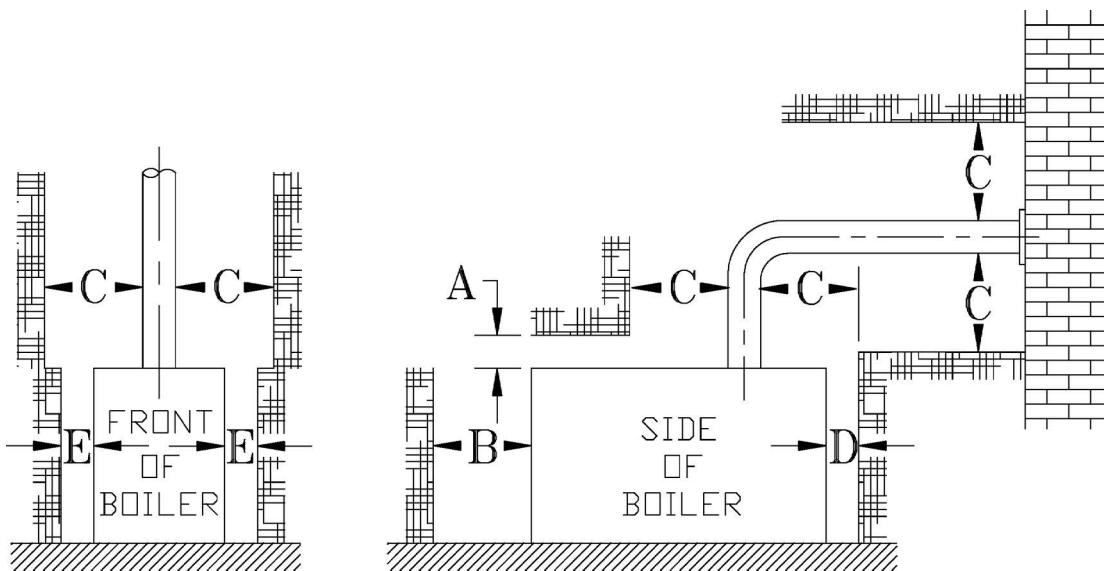

**Figure 2-1: Minimum Clearances to Combustible Materials**

A	B	C	D	E
Above	Front	Chimney Connector	Rear	Sides
18	48	18	18	18

NOTE 1: Listed clearances comply with American National Standard NFPA 31, Standard for the Installation of Oil Burning Equipment.

NOTE 2: AP-U™ Series boilers can be installed in rooms with clearances from combustible material as listed above. Listed clearances cannot be reduced for alcove or closet installations.

NOTE 3: For reduced clearances to combustible material, protection must be provided as described in the ANSI/NFPA 31 standard.

## 2 Pre-Installation *(continued)*

### C. REMOVE CRATE

1. Remove all fasteners at crate skid.
2. Lift outside container and remove all other inside protective spacers and bracing. Remove accessory parts carton.

### D. REMOVE BOILER FROM SKID

1. Remove four (4) hex head lag screws, attaching boiler base plate to shipping skid.
2. Carefully, walk boiler to the edge of the skid. Tilt the boiler back, allowing boiler base edge to rest on the floor, then, remove the skid.
3. Position boiler for final installation.

### E. PROVIDE COMBUSTION AND VENTILATION AIR.

Local code provisions may apply and should be referenced.

#### WARNING

Adequate combustion and ventilation air must be provided to assure proper combustion and to maintain safe ambient air temperatures. **DO NOT** install boiler where gasoline or other flammable vapors or liquids, or sources of hydrocarbons (i.e. bleaches, fabric softeners, etc.) are used or stored.

1. Determine volume of space (boiler room). Rooms communicating directly with the space in which the appliances are installed, through openings not furnished with doors, are considered a part of the space.  

$$\text{Volume}(\text{ft}^3) = \text{Length}(\text{ft}) \times \text{Width}(\text{ft}) \times \text{Height}(\text{ft})$$
2. Determine total input of all appliances in the space.  
 Add inputs of all appliances in the space and round the result to the nearest 1,000 BTU per hour.
3. Determine type of space. Divide Volume by total input of all appliances in space. If the result is greater than or equal to 50 ft<sup>3</sup>/1000 BTU per hour, then it is considered an **unconfined space**. If the result is less than 50 ft<sup>3</sup>/1,000 BTU per hour then the space is considered a **confined space**.
4. For boiler located in an **unconfined space of a conventionally constructed building**, the fresh air infiltration through cracks around windows and doors normally provides adequate air for combustion and ventilation.

5. For boiler located in a confined space or an unconfined space in a building of unusually tight construction, provide outdoor air with the use of two permanent openings which communicate directly or by duct with the outdoors or spaces (crawl or attic) freely communicating with the outdoors. Locate one opening within 12 inches of top of space. Locate remaining opening within 12 inches of bottom of space. Minimum dimension of air opening is 3 inches. Size each opening per following:
  - a. Direct communication with outdoors. Minimum free area of 1 square inch per 4,000 BTU per hour input of all equipment in space.
  - b. Vertical ducts. Minimum free area of 1 square inch per 4,000 BTU per hour input of all equipment in space. Duct cross-sectional area shall be same as opening free area.
  - c. Horizontal ducts. Minimum free area of 1 square inch per 2,000 BTU per hour input of all equipment in space. Duct cross-sectional area shall be same as opening free area.

**Alternate method for boiler located within confined space.** Use indoor air if two permanent openings communicate directly with additional space(s) of sufficient volume such that combined volume of all spaces meet criteria for unconfined space. Size each opening for minimum free area of 1 square inch per 1,000 BTU per hour input of all equipment in spaces, but not less than 100 square inches.

### 6. Louvers and Grilles of Ventilation Ducts

- a. All outside openings should be screened and louvered. Screens used should not be smaller than 1/4 inch mesh. Louvers will prevent the entrance of rain and snow.
- b. Free area requirements need to consider the blocking effect of louvers, grilles, or screens protecting the openings. If the free area of the louver or grille is not known, assume wood louvers have 20-25 percent free area and metal louvers and grilles have 60-75 percent free area.
- c. Louvers and grilles must be fixed in the open position, or interlocked with the equipment to open automatically during equipment operation.

## 2 Pre-Installation *(continued)*

### INSTALLATION INSTRUCTIONS FOR OPTIONAL SHIELD REQUIRED FOR COMBUSTIBLE FLOOR

This shield for combustible floors is intended for use **only** with the following New Yorker oil-fired boilers:

Use Part Number 6183504 for the following models:

AP-110U AP-154U  
ADDS 4-3/16 in. TO BOILER HEIGHT

1. Place shield on combustible floor with "TOP" surface upward and "FRONT" surface directly below the expected position of the oil burner.
2. Locate shield such that clearances to combustible walls are as indicated in Figure 2-2. These dimensions will assure that the boiler jacket will be at least 18 in. from the side and rear walls and 48 in. from the front wall, as required by ANSI/NFPA 31.
3. Fasten shield to combustible floor to keep shield from shifting position during setting of boiler.
4. Set boiler squarely on top of shield such that base plate of boiler rests flat on top surface of shield and does not over-hang shield on any side. Confirm clearance to combustible walls. Refer to Figure 2-1.
5. **DO NOT** enclose boiler (including shield) on all four sides. Boiler may be enclosed on any three sides while maintaining minimum clearances shown in Figure 2-1 for each of those three sides.

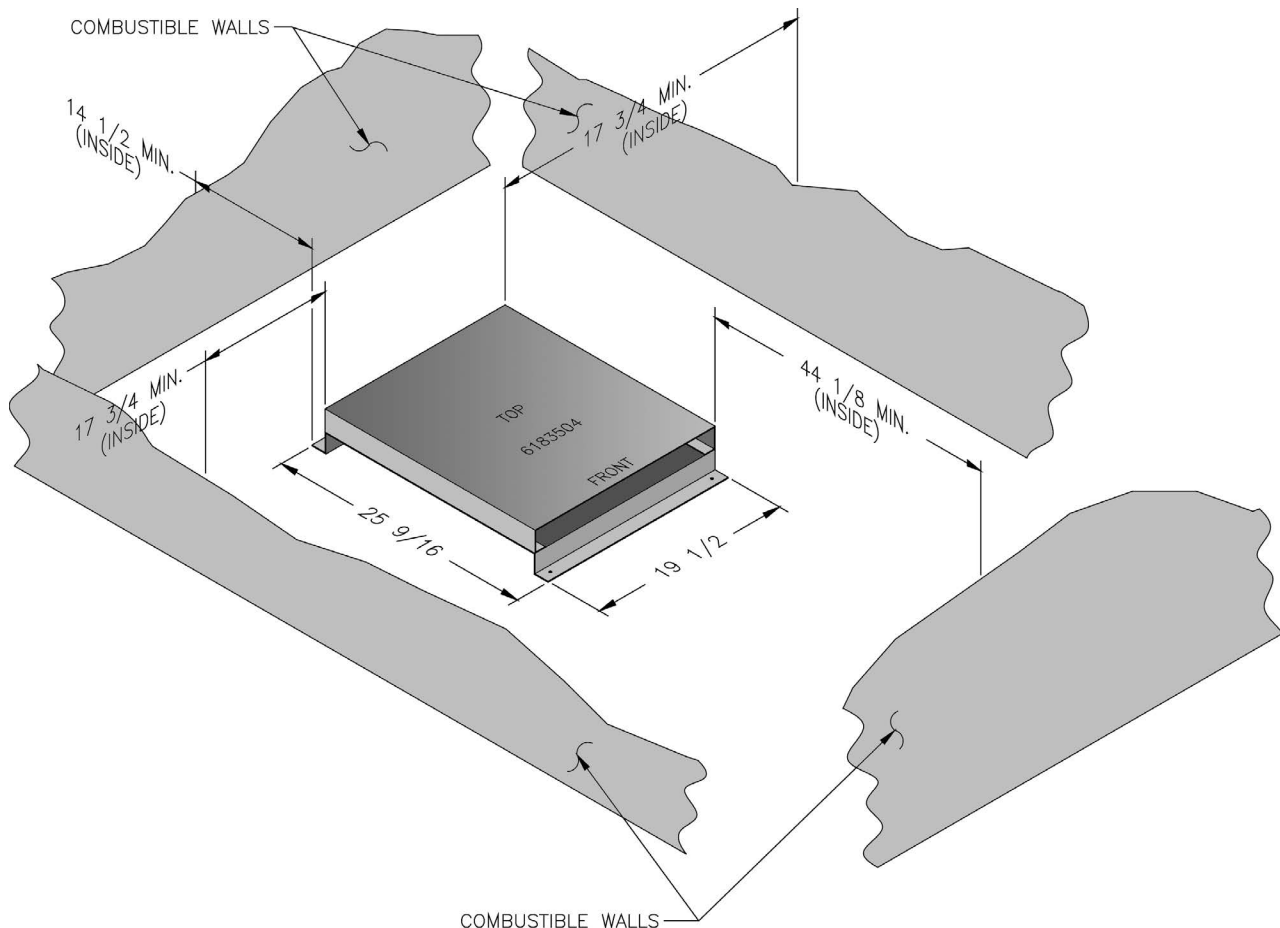

**Figure 2-2: Floor Shield**

### 3 Water Piping and Trim

#### ⚠ WARNING

Failure to properly pipe boiler may result in improper operation and damage to boiler or structure.

Oxygen contamination of boiler water will cause corrosion of iron and steel boiler components, and can lead to boiler failure. New Yorker's Standard Warranty does not cover problems caused by oxygen contamination of boiler water or scale (lime) build-up caused by frequent addition of water.

- A. DESIGN A PIPING SYSTEM and install boiler which will prevent oxygen contamination of boiler water and frequent water additions.
1. There are many possible causes of oxygen contamination such as:
    - a. Addition of excessive make-up water as a result of system leaks.
    - b. Absorption through open tanks and fittings.
    - c. Oxygen permeable materials in the distribution system.
  2. In order to insure long product life, oxygen sources should be eliminated. This can be accomplished by taking the following measures:
    - a. Repairing system leaks to eliminate the need for addition of make-up water.
    - b. Eliminating open tanks from the system.
    - c. Eliminating and/or repairing fittings which allow oxygen absorption.
    - d. Use of non-permeable materials in the distribution system.
    - e. Isolating the boiler from the system water by installing a heat exchanger.
  3. Connect System supply and return piping to boiler. See Figures 3-3 and 3-4. Also, consult I=B=R, "Residential Hydronic Heating Installation and Design Guide". Maintain minimum ½ inch clearance from hot water piping to combustible materials.

#### ⚠ WARNING

System supply and return piping must be connected to correct boiler pipe.

New Yorker recommends sizing the system circulator to supply sufficient flow (GPM) to allow a 20°F temperature differential in the system. When sizing the system circulator, the pressure drop of all radiators, baseboard and radiant tubing and all connecting piping must be considered.

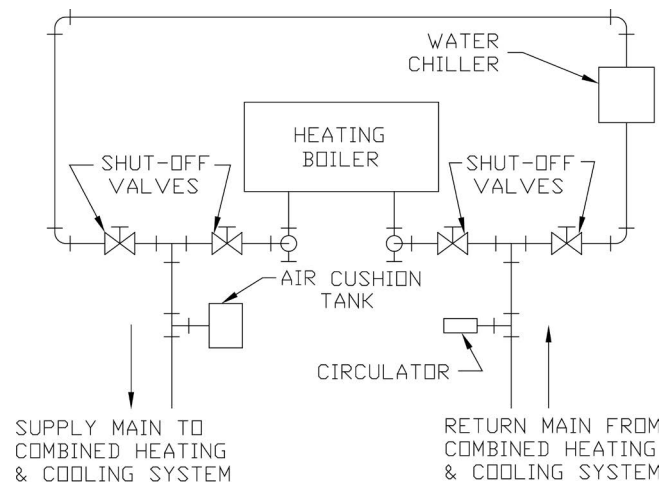

**Figure 3-1: Recommended Piping for Combination Heating and Cooling (Refrigeration) System**

- a. If this boiler is used in connection with refrigeration systems, the boiler must be installed so that the chilled medium is piped in parallel with the heating boiler using appropriate valves to prevent the chilled medium from entering the boiler. See Figure 3-1. Also, consult I=B=R, "Residential Hydronic Heating Installation and Design Guide".
- b. If this boiler is connected to heating coils located in air handling units where they may be exposed to refrigerated air, the boiler piping must be equipped with flow control valves to prevent gravity circulation of boiler water during the operation of the cooling system.
- c. If boiler is used with an Indirect-Fired Domestic Water Heater, install the Indirect-Fired Domestic Water Heater as a separate heating zone. Refer to the Indirect-Fired Domestic Water Heater Installation, Operating, and Service Instructions for additional information.

### 3 Water Piping and Trim *(continued)*

- d. Use a system bypass if the boiler is to be operated in a system which has a large volume or excessive radiation where low boiler water temperatures may be encountered (i.e. converted gravity circulation system, etc.) The bypass should be the same size as the supply and return lines with valves located in the bypass and return line as illustrated in Figures 3-3 and 3-4 in order to regulate water flow for maintenance of higher boiler water temperature. Set the bypass and return valves to a half throttle position to start. Operate boiler until the system water temperature reaches its normal operating range. Adjust the valves to maintain 180°F to 200°F boiler water temperature and greater the 120°F return temperature. Adjust both valves simultaneously. Closing the boiler return valve while opening the bypass valve will raise the boiler return temperature. Opening the boiler return valve while closing the by-pass valve will lower the boiler return temperature.
- e. A water boiler installed above radiation level must be provided with a low water cutoff device as part of the installation.
- B. INSTALL SAFETY RELIEF VALVE. See Figures 3-2, 3-3 and 3-4. Safety Relief Valve must be installed with spindle in the vertical position. Installation of the relief valve must be consistent with ANSI/ASME Boiler and Pressure Vessel Code, Section IV.

#### WARNING

Installation is NOT complete unless a safety relief valve is installed as shown in Figure 3-2. Safety (relief) valve discharge piping must be piped near floor to eliminate potential of severe burns. DO NOT pipe in any area where freezing could occur. DO NOT install any shut-off valves, plugs or caps.

- C. AIR VENT. An air vent or purge must be incorporated in the system to easily remove air from the boiler when the system is filled. The boiler has a built in dip tube which works with the air vent to clear the boiler of air. Improper application of the air vent will cause steaming in the boiler. See Figures 3-2, 3-3 and 3-4.

- D. INSTALL DRAIN VALVE in return piping. See Figures 3-3 and 3-4.
- E. OIL, GREASE, AND OTHER FOREIGN MATERIALS which accumulate in new hot water and a new or reworked system should be boiled out, and then thoroughly flushed. A qualified water treatment chemical specialist should be consulted for recommendations regarding appropriate chemical compounds and concentrations which are compatible with local environmental regulations.

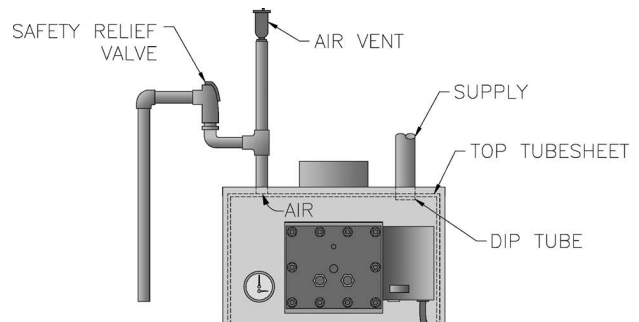

**Figure 3-2: Air Vent and Safety Relief Valve Installation Detail**

- F. AFTER THE BOILER AND SYSTEM HAVE BEEN CLEANED and flushed, and before refilling the entire system add appropriate water treatment chemicals, if necessary, to bring the pH between 7 and 11.
- G. CONNECT TANKLESS HEATER PIPING AS SHOWN IN FIGURE 3-5. See Table 3-6 for Tankless Heater Rating.

#### WARNING

Install automatic mixing valve at tankless heater outlet to avoid risk of burns or scalding due to excessively hot water at fixtures. Adjust and maintain the mixing valve in accordance with the manufacturer's instructions. DO NOT operate tankless heater without mixing valve.

### 3 Water Piping and Trim (continued)

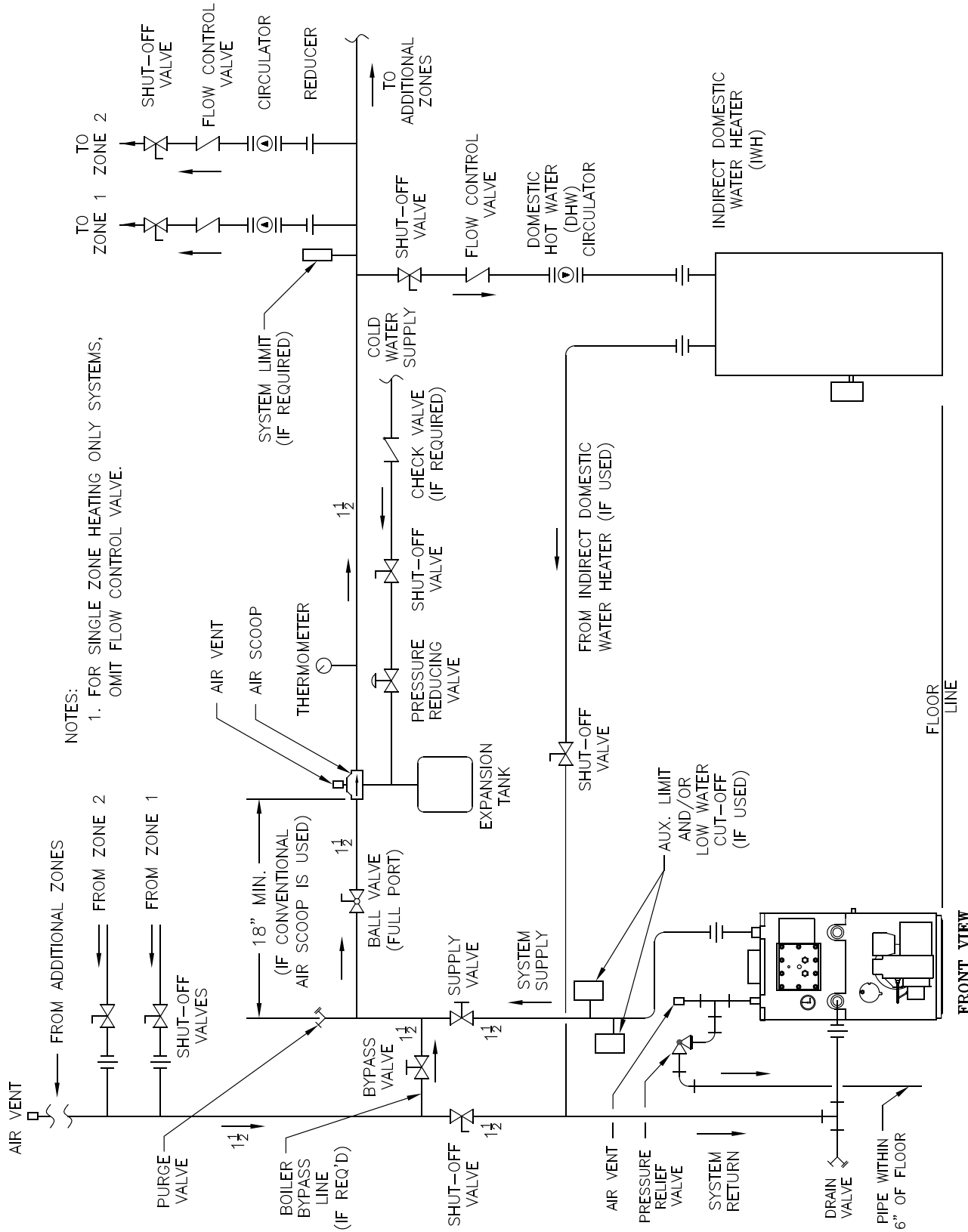
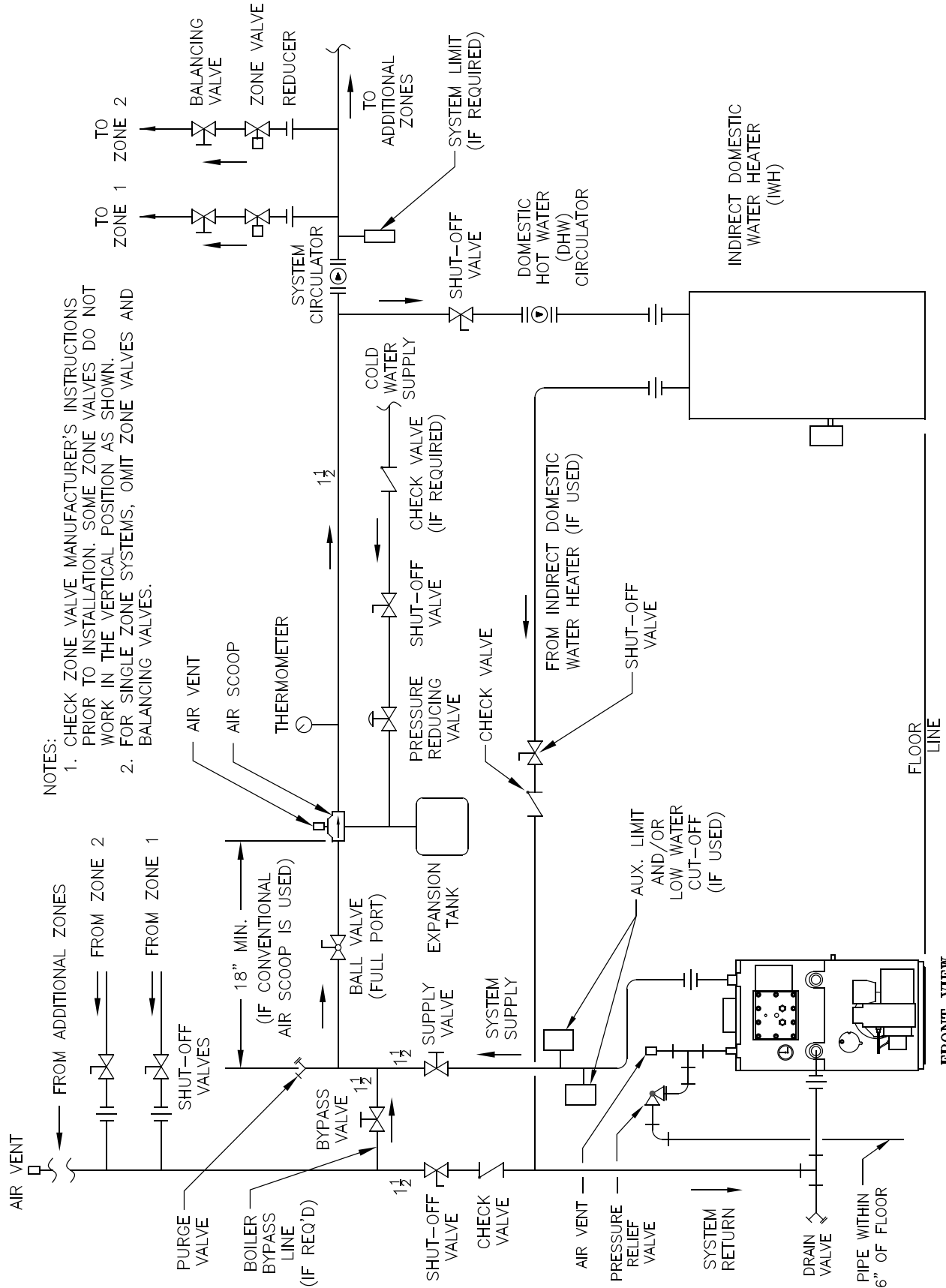

Figure 3-3: Recommended Boiler Piping for Circulator Zoned Heating Systems, Supply Side Circulator

### 3 Water Piping and Trim (continued)



**Figure 3-4: Boiler Piping for Zone Valve Zoned Heating Systems, Supply Side Circulator**

### 3 Water Piping and Trim *(continued)*

THE FOLLOWING GUIDELINES SHOULD BE FOLLOWED WHEN PIPING THE TANKLESS HEATER:

1. **FLOW REGULATION** — If flow through the heater is greater than its rating, the supply of adequate hot water may not be able to keep up with the demand. For this reason a flow regulator matching the heater rating should be installed in the cold water line to the heater. The flow regulator should preferably be located below the inlet to the heater and a minimum of 3' away from the inlet so that the regulator is not subjected to excess temperatures that may occur during "off" periods when it is possible for heat to be conducted back through the supply line. The flow regulator also limits the flow of supply water regardless of inlet pressure variations in the range of 20 to 125 psi.
2. **TEMPERING OF HOT WATER** — Installation of an automatic mixing valve will lengthen the delivery of the available hot water by mixing some cold water with the hot. This prevents the possibility of scalding hot water at the fixtures. In addition, savings of hot water will be achieved since the user will not waste as much hot water while seeking a water temperature. Higher temperature hot water required by

dishwashers and automatic washers is possible by piping the hot water from the heater prior to entering the mixing valve. The mixing valve should be "trapped" by installing it below the cold water inlet to heater to prevent lime formation in the valve. Refer to Figure 3-5.

3. **FLUSHING OF HEATER** — All water contains some sediment which settles on the inside of the coil. Consequently, the heater should be periodically backwashed. This is accomplished by installing hose bibs as illustrated and allowing water at city pressure to run into hose bib A, through the heater, and out hose bib B until the discharge is clear. The tees in which the hose bibs are located should be the same size as heater connections to minimize pressure drop.
4. **HARD WATER** — A water analysis is necessary to determine the hardness of your potable water. This is applicable to some city water and particularly to well water. An appropriate water softener should be installed based on the analysis and dealer's recommendation. This is not only beneficial to the tankless heater but to piping and fixtures plus the many other benefits derived from soft water.

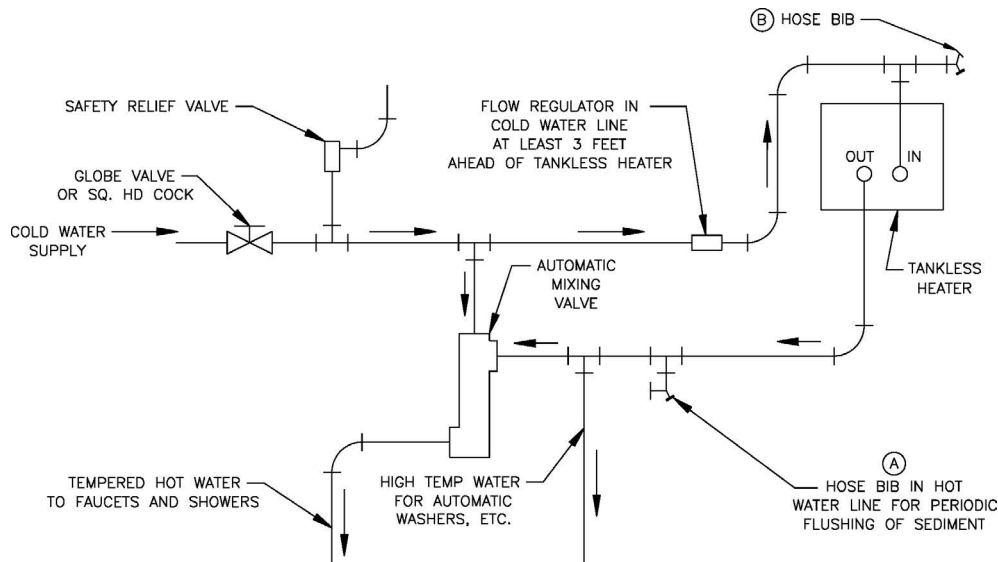

**Figure 3-5: Schematic Tankless Heater Piping**

**Table 3-6: Tankless Heater Ratings**

Boiler Model	Tankless Heater Model	
	S-5A	
	GPM	PSID
AP-110U-T	3½	15
AP-154U-T	3¾	25

## 4 Venting

### A. GENERAL GUIDELINES.

1. Vent system installation must be in accordance with these instructions and applicable provisions of local building codes. Contact local building or fire officials about restrictions and installation inspection in your area.
2. The AP-U Series is designed to be vented into a fireclay tile-lined masonry chimney or chimney constructed from type-L vent or a factory built chimney that complies with the type HT requirements of UL103. The chimney or vent pipe shall have a sufficient draft at all times, to assure safe proper operation of the boiler. See Figure 8 for recommended installation.
  - a. Install a draft regulator (supplied by installer) following the instructions furnished with the regulator. See Figure 4-2 for alternate regulator locations.
  - b. With any new or replacement installation the chimney has to be considered. Chimneys that have a high heat loss become less suitable as the heat loss of the home goes down and the efficiency of the boiler goes up. Most homes have a chimney appropriate for the fuel and the era in which the home was built. That may have been a coal fired or an inefficient oil fired boiler built into a home without insulation or storm windows. With increasing fuel prices that home probably has been insulated and fitted with storm windows so that the heat loss of the home has been reduced. This requires less fuel to be burned and sends less heat up the chimney.

A new boiler probably has a higher efficiency than the boiler being replaced. That probably means that the stack temperature from the new boiler will be lower than that from the old boiler and with less room air being drawn up the chimney to dilute the stack gases. The combination of a large uninsulated chimney, reduced firing rate, reduced firing time, lower stack temperature and less dilution air can, in some cases, contribute to the condensing of small amounts of water vapor in the chimney. Such condensation, when it occurs, can cause chimney deterioration. In extreme cases, the chimney may have to be lined to insulate the chimney and thus prevent the condensation. The addition of dilution air into the chimney may assist in drying the chimney interior surfaces. A massive chimney on a cold, or exposed outside wall may have produced adequate draft when it was fired with a higher input and greater volumes of heated gases. With reduced input and volume, the draft may be severely affected. In one instance our research showed a new chimney of adequate sizing produced only  $-.035''$  W.C. after 30 minutes of continuous firing at 13.0%  $\text{CO}_2$ . Outside wall chimneys take longer to heat up and can have  $.00''$  W.C. draft at burner start-up. You may have to consider a special alloy chimney flue liner with insulation around it and stabilizing draft cap or even a draft inducing fan in severe cases.

- c. For the same reasons as in (2.) above, heat extractors mounted into the breeching are not recommended.
3. For minimum clearances to combustible materials refer to Figure 2-1.

# 4 Venting *(continued)*

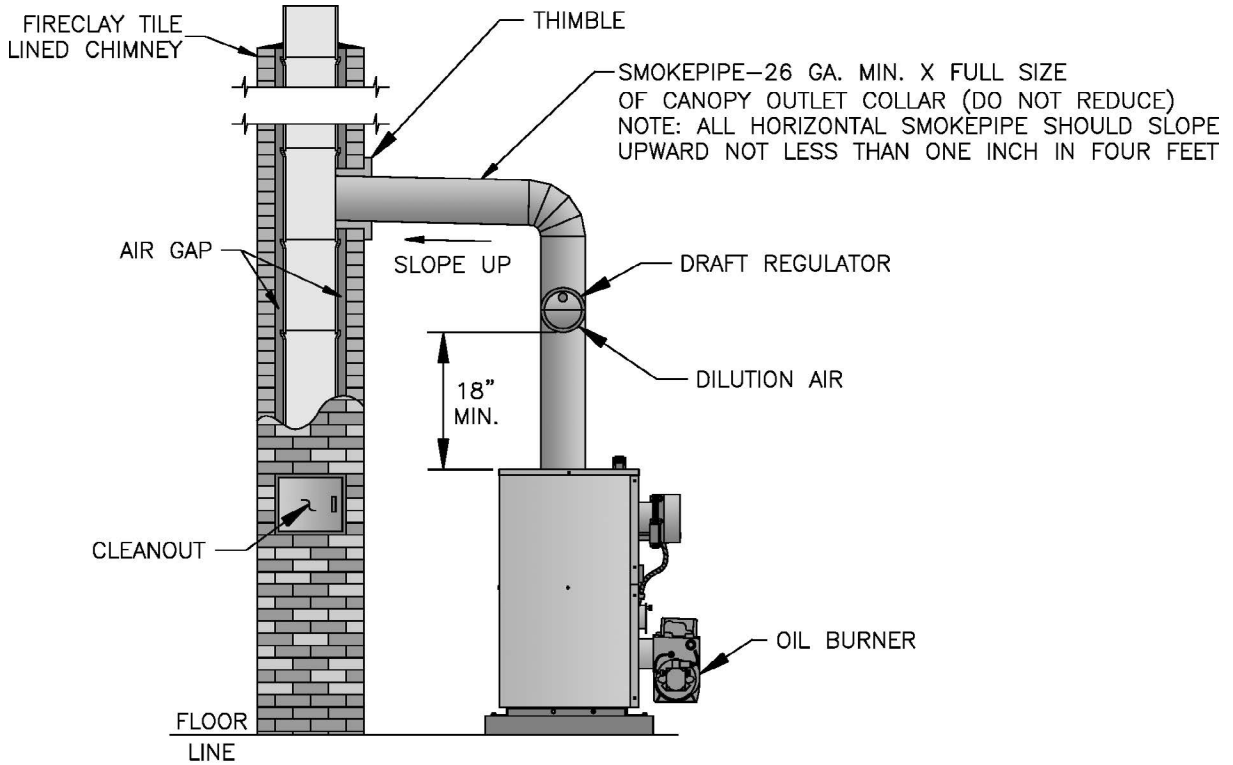

LEFT SIDE VIEW

Figure 4-1: Recommended Smokepipe Arrangement and Chimney Requirements

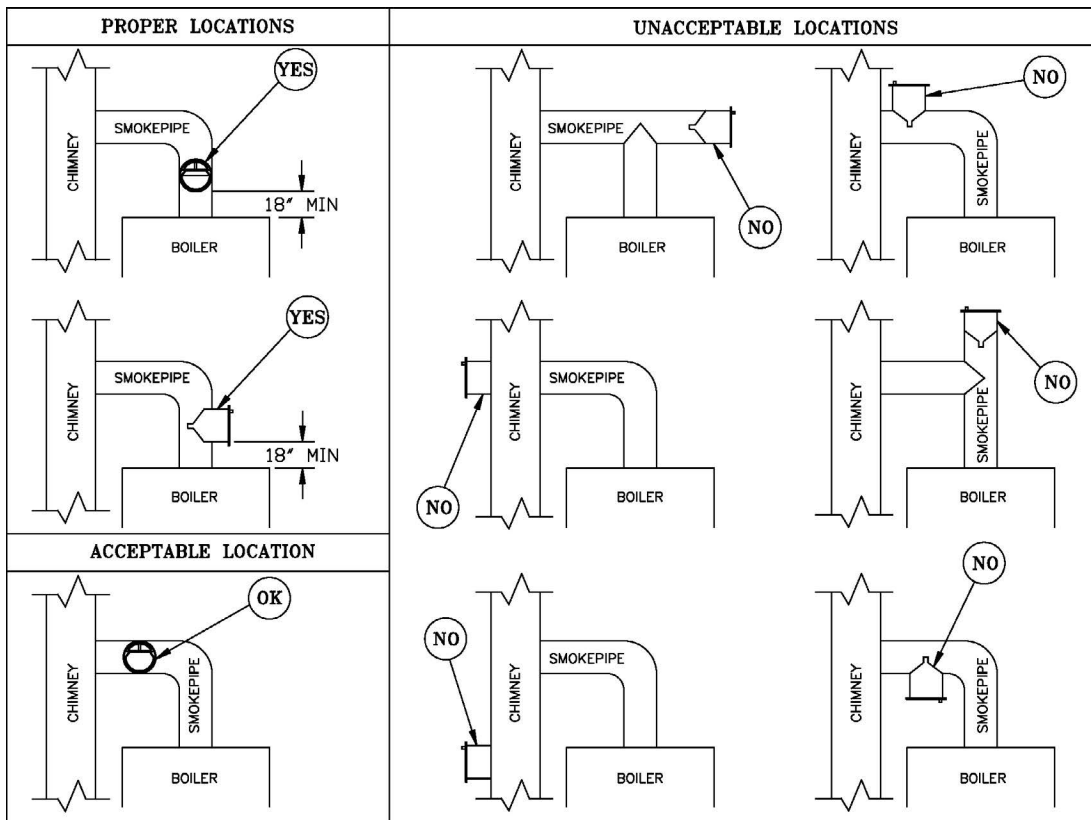

Figure 4-2: Draft Regulator Locations

## 5 Electrical

### DANGER

Positively assure all electrical connections are unpowered before attempting installation or service of electrical components or connections of the boiler or building. Lock out all electrical boxes with padlock once power is turned off.

### WARNING

- Failure to properly wire electrical connections to the boiler may result in serious physical harm.
- Electrical power may be from more than one source. Make sure all power is off before attempting any electrical work.
- Each boiler must be protected with a properly sized fused disconnect.
- Never jump out or make inoperative any safety or operating controls.
- The wiring diagrams contained in this manual are for reference purposes only. Refer to the wiring diagram of any controls used with the boiler. Read, understand and follow all wiring instructions supplied with the controls.

#### A. GENERAL

1. Install wiring and electrically ground boiler in accordance with requirements of the authority having jurisdiction, or in absence of such requirements the National Electrical Code, ANSI/NFPA 70, and/or the CSA C22.1 Electric Code.
2. A separate electrical circuit must be run from the main electrical service with an over-current device/disconnect in the circuit. A service switch is recommended and may be required by some local jurisdictions.
3. Wiring should conform to Figure 5-1.

#### B. SYSTEM CONTROLS AND WIRING

1. Refer to National Electric Code or Local Electric Codes for proper size and type of wire required. Follow Code.
2. Use anti-short bushings on all wiring passing through boiler jacket, junction boxes and/or control boxes.
3. Use armored cable (BX) over all exposed line voltage wiring.
4. If an indirect water heater is used, use priority zoning. **DO NOT** use priority zoning for Hydro-Air Systems.
5. Single Zone System – Refer to Figure 5-1 for the electrical diagram for this type of system. Connect the system circulator wire leads to the proper locations on the control. See Figure 5-1.

- #### C. INSTALL A ROOM THERMOSTAT
- on an inside wall about four feet above floor. Never install thermostat on an outside wall or where it will be influenced by drafts, hot or cold water pipes, lighting fixtures, television, rays of the sun or near a fireplace. Keep large furniture away from thermostat so there will be free movement of room air around this control.

Connect the thermostat to the 'T-T' terminals on the control.

### WARNING

The maximum allowable current for each circulator is 5 amps at 120 VAC. For circulators with higher amp ratings, you must install a circulator relay or starter coil to provide line voltage to the circulator and connect only the relay or starter coil to boiler terminals. The combined boiler and circulator amperage must not exceed 15 amps.

Install over-current protection in accordance with authority having jurisdiction or, in the absence of such requirements, follow the National Electric Code, NFPA 70, and/or CSA C22.1 Electrical Code. DO NOT provide over-current protection greater than 15 amperes.

# 5 Electrical *(continued)*

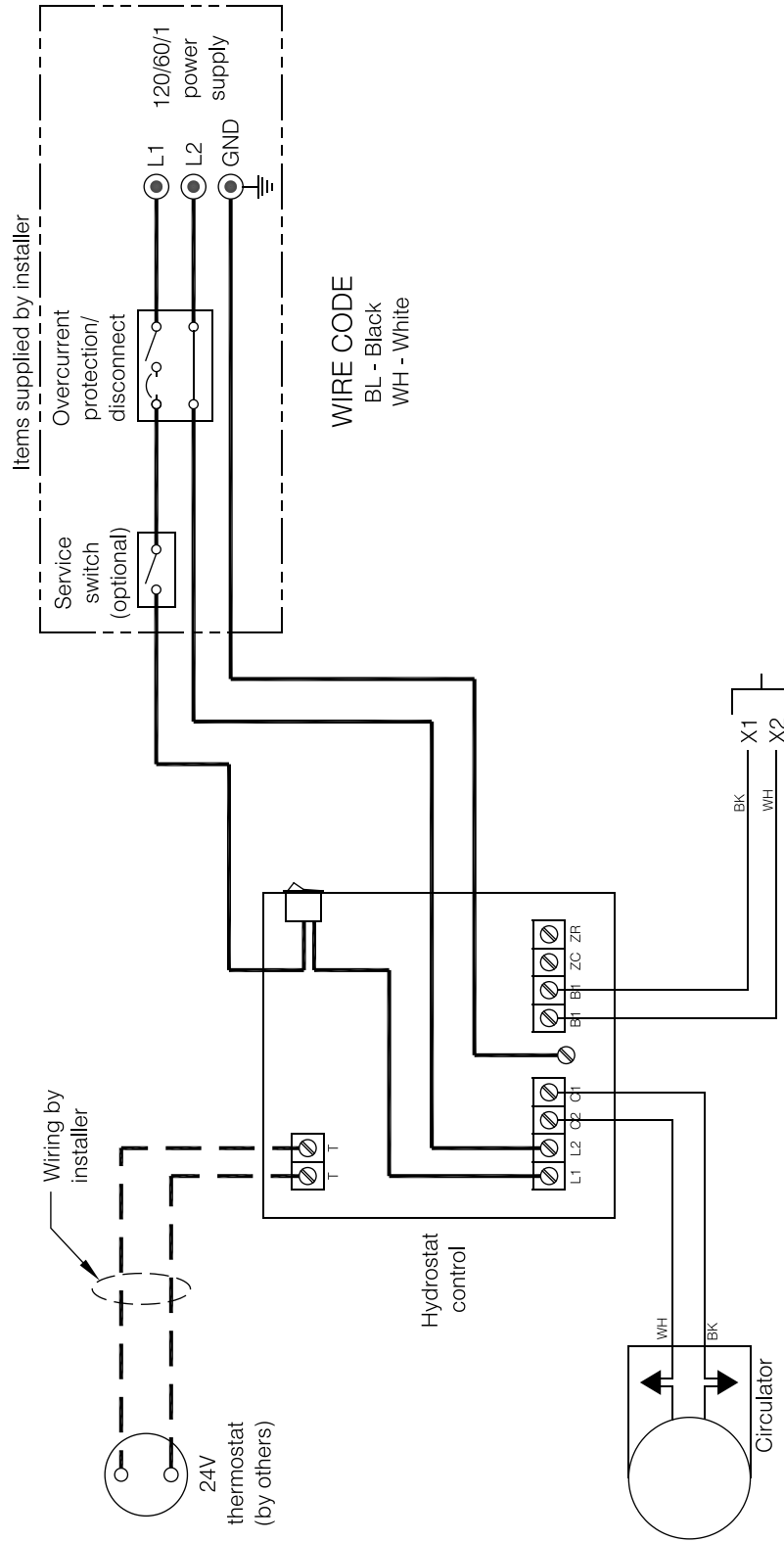

**SCHEMATIC DIAGRAM LEGEND**

- Line voltage size 14 AWG type TW wire
- Line voltage size 18 AWG type TW or TEW/AWM wire - 105°C
- Line voltage size 18/2 AWG type CL2X or power limited circuit cable - 75-105°

- Screw terminal
- ▲ Wire nut

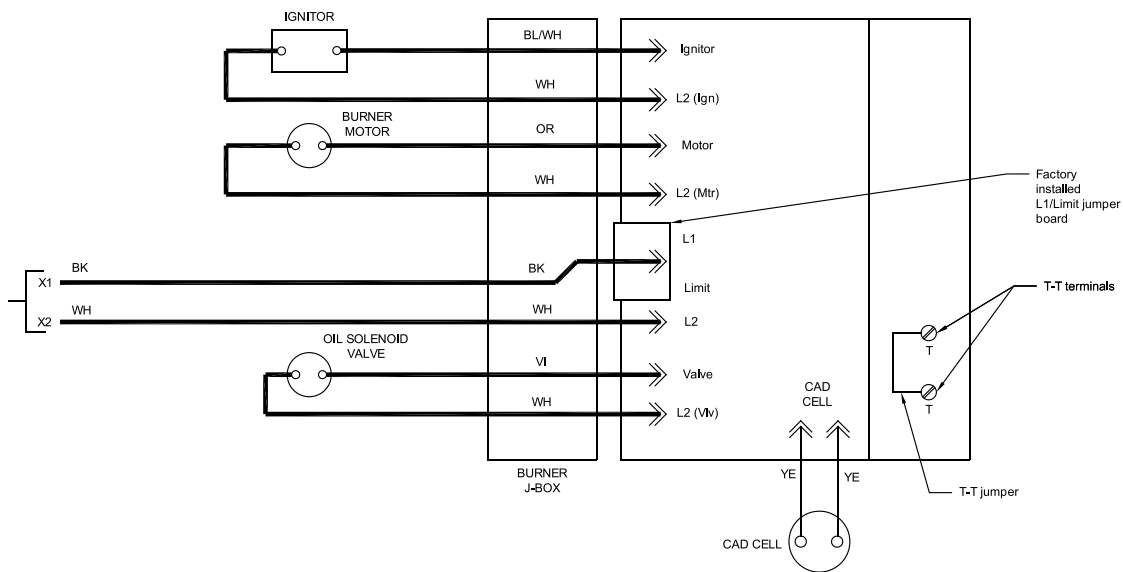

**Figure 5-1: Schematic Wiring Diagram**

# 5 Electrical *(continued)*



BECKETT AFG BURNER WITH GeniSys OIL PRIMARY CONTROL





**SCHEMATIC DIAGRAM LEGEND**

-  Screw terminal
-  Quick connect receptacle

**WIRE COLORS**

- BK - Black
- BL/WH - Blue w/ white tracer
- WH - White
- VI - Violet
- YE - Yellow
- OR - Orange

**WIRE TYPE LEGEND**

-  Low voltage factory wiring (size 18 AWG, 105°C)
-  Low voltage field wiring
-  Line voltage factory wiring (size 18 AWG, 105°C)
-  Line voltage field wiring

**Notes:**

1. If any original equipment wire as supplied with the appliance must be replaced, it must be replaced with wire having the same wire gauge (AWG), same wire type, and rated for a minimum of 105°C.

**Figure 5-2: Schematic Wiring Diagram**

## 6 Oil Piping

**NOTICE:** The National Oil Heat Research Alliance (NORA) recommends single pipe oil systems and high-quality filtration for all fuel types. This should include at least a 10-micron Spin-on filter. Double filtration provides even greater assurance clean fuel will get to the pump. Contaminants in the tank that enter the fuel supply to the burner can cause pump sticking/seizing. These contaminants may increase in the early stages of transitioning to modern fuels (Ultra Low Sulfur and Bio Blends). High quality filtration adds protection against pump sticking

### A. GENERAL.

1. Use flexible oil line(s) so that burner can be removed without disconnecting the oil supply.
2. A supply line fuel oil filter is recommended as a minimum for all firing rates but a pleated paper fuel oil filter is recommended for the lowest firing rate application to prevent nozzle fouling.
3. Use Flared fittings only. **DO NOT** use compression fittings.

4. Use of a high efficiency micron filter (Garber or equivalent) in addition to conventional filter is highly recommended.

### B. SINGLE-PIPE OIL LINES.

1. Standard burners are provided with single-stage 3450 rpm fuel units with the bypass plug removed for single-pipe installations.
2. The single-stage fuel unit may be installed single-pipe with gravity feed or lift. Maximum allowable lift is 8 feet. See Figure 6-1.

**NOTICE:** Oil piping must be absolutely airtight or leaks or loss of prime may result. Bleed line and fuel unit completely.

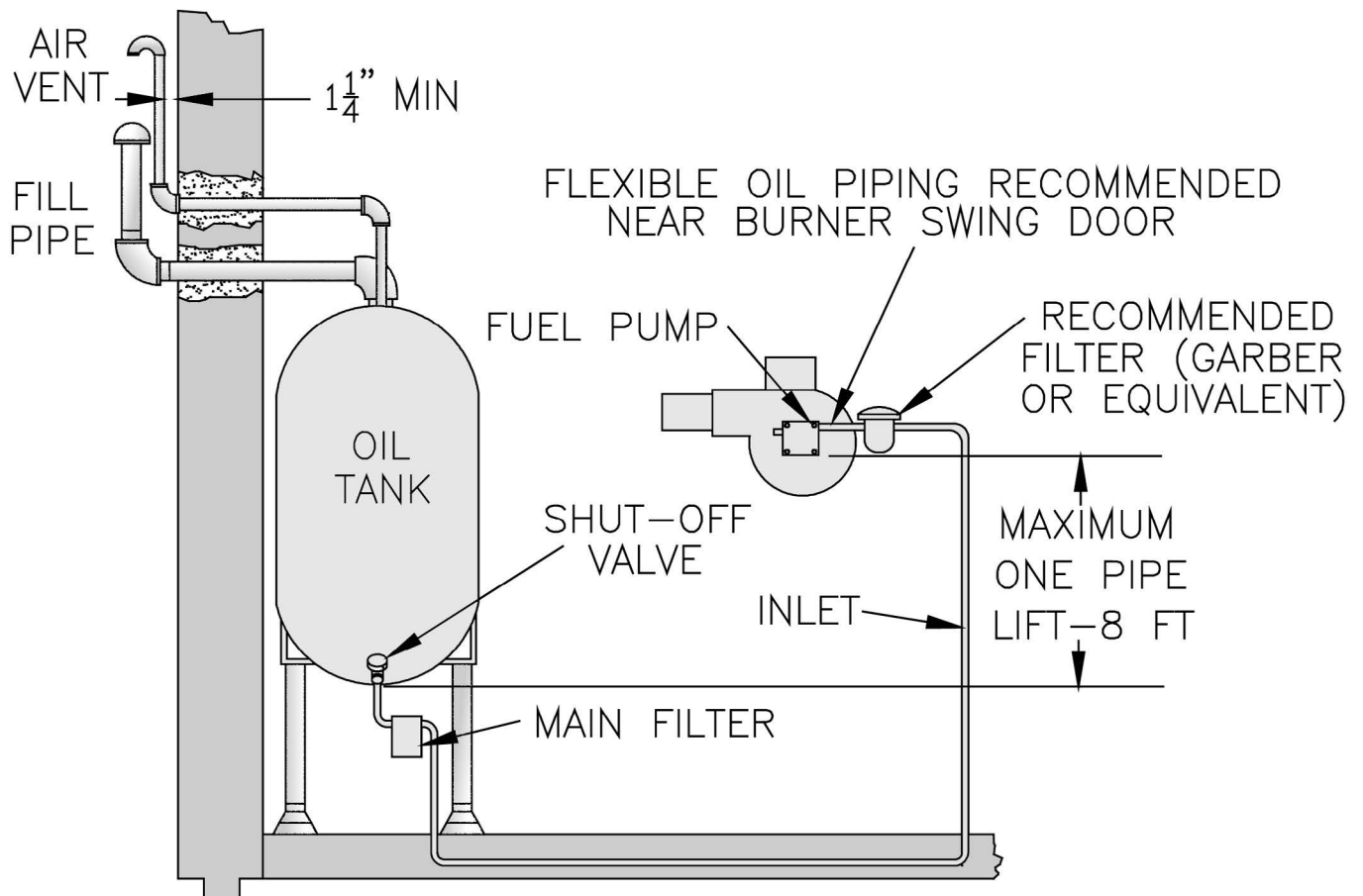

Figure 6-1: Single-Pipe Installation

## 6 Oil Piping *(continued)*

**Table 6-2: Single Stage Units (3450 RPM)  
Two Pipe Systems**

Lift "H" (See Figure 6-4)	Maximum Length of Tubing "H" + "R"	
	3/8 in. OD Tubing (3 GPH)	1/2 in. OD Tubing (3 GPH)
0'	84'	100'
1'	78'	100'
2'	73'	100'
3'	68'	100'
4'	63'	100'
5'	57'	100'
6'	52'	100'
7'	47'	100'
8'	42'	100'
9'	36'	100'
10'	31'	100'
11'	26'	100'
12'	21'	83'
13'	---	62'
14'	---	41'

**Table 6-3: Two-Stage Units (3450 RPM)  
Two Pipe Systems**

Lift "H" (See Figure 6-4)	Maximum Length of Tubing "H" + "R"	
	3/8 in. OD Tubing (3 GPH)	1/2 in. OD Tubing (3 GPH)
0'	93'	100'
2'	85'	100'
4'	77'	100'
6'	69'	100'
8'	60'	100'
10'	52'	100'
12'	44'	100'
14'	36'	100'
16'	27'	100'
18'	---	76'

### C. TWO-PIPE OIL LINES

- For two-piped systems, where more lift is required, the two-stage fuel unit is recommended. Table 6-2 (single-stage) and Table 6-3 (two-stage) show allowable lift and lengths of 3/8 inch and 1/2 inch OD tubing for both suction and return lines. Refer to Figure 6-4.

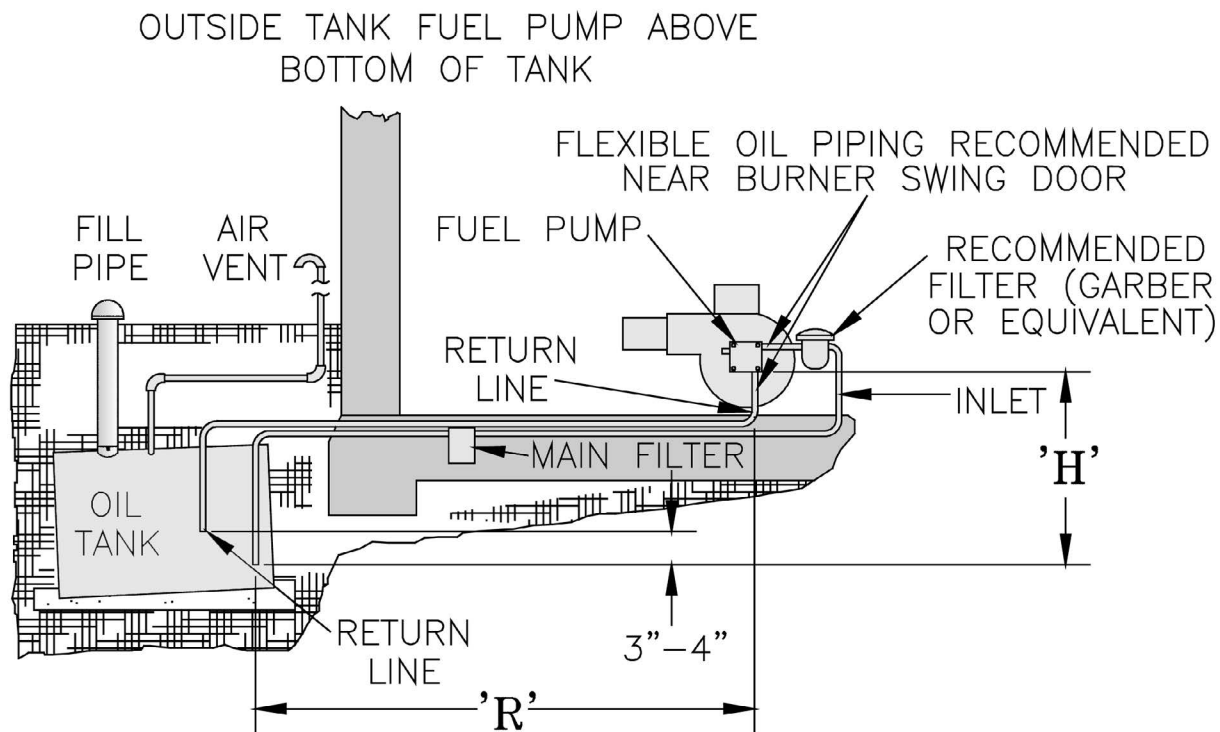

**Figure 6-4: Two-Pipe Installation**

## 7 System Start-Up

### A. ALWAYS INSPECT INSTALLATION BEFORE STARTING BURNER.

1. Verify that the venting, water piping, oil piping, and electrical system are installed properly. Refer to Installation Instructions contained in this manual.
2. Confirm all electrical, water and oil supplies are turned off at the source and that the vent is clear from obstructions.

#### WARNING

Completely read, understand and follow all instructions in this manual before attempting start up.

### B. FILL HEATING SYSTEM WITH WATER.

**CLEAN HEATING SYSTEM** if boiler water is dirty. Refer to Maintenance and Service Instructions Section of this manual for proper cleaning instructions for water boilers.

1. Fill entire heating system with water and vent air from system. Use the following procedure on a series loop or multi-zoned system installed as per Figures 3-3, and 3-4, to remove air from system when filling:
  - a. Close full port ball valve in boiler system piping.
  - b. Isolate all zones by closing zone valves or shut-off valves in supply and return of each zone(s).
  - c. Attach a hose to vertical purge valve in boiler system piping.  
(**Note** - Terminate hose in five gallon bucket at a suitable floor drain or outdoor area).
  - d. Starting with one zone at a time, open zone valve or shut-off valve in boiler supply and return piping.
  - e. Open purge valve.
  - f. Open shut-off valve in cold water supply piping located between the air scoop and expansion tank.
  - g. Allow water to overflow from bucket until discharge from hose is bubble free for 30 seconds.
  - h. When zone is completely purged of air, close zone valve or shut-off valve. Open zone valve to the next zone to be purged. Repeat this step until all zones have been purged. At completion, open all zone valves.

- i. Close purge valve, continue filling the system until the pressure gauge reads 12 psi. Close shut-off valve in cold water supply piping.

**Note** - If make-up water line is equipped with pressure reducing valve, system will automatically fill to 12 psig.

**NOTICE:** If make-up water line is equipped with pressure reducing valve, system will automatically fill to 12 psi. Follow fill valve manufacturer's instructions.

#### WARNING

The maximum operating pressure of this boiler is posted on the ASME Data Label located on the top of the boiler. Never exceed this pressure. **DO NOT** plug safety or relief valve.

- j. Open full port ball valve in boiler system piping.
  - k. Remove hose from purge valve.
  - l. Confirm that the boiler and system have no water leaks.
- C. **CHECK CONTROL, WIRING AND BURNER** to be sure that all connections are tight and burner is rigid, that all electrical connections have been completed and fuses installed, and that oil tank is filled and oil lines have been tested.
- D. **LUBRICATION.** Follow instruction on burner and circulator label to lubricate, if oil lubricated. Most motors currently used on residential type burners employ permanently lubricated bearings and thus **DO NOT** require any field lubrication. Water lubricated circulators **DO NOT** need field lubrication.
- E. **ADJUST CONTROL SETTINGS** with burner service switch turned "ON".
1. **SET ROOM THERMOSTAT** about 10°F below room temperature.
  2. **PRESS RED RESET BUTTON** on Oil Primary Control. Hold button for ten (10) seconds and release to reset primary control.
  3. **WATER BOILERS WITHOUT TANKLESS HEATERS** The Boiler Control is factory programmed with a High Limit setpoint of 190°F. The High Limit setpoint is adjustable between 100°F and 220°F. This temperature may be varied to suit the installation requirements.

## 7 System Start-Up *(continued)*

### 4. WATER BOILERS WITH TANKLESS HEATERS:

The Warm Start Boiler Control is factory programmed with a High Limit setpoint of 190°F. The High Limit setpoint is adjustable between 100°F and 220°F. Additionally, the Warm Start Boiler Control is factory programmed with a Low Limit setpoint off The Low Limit setpoint is adjustable between 110°F and 200°F. These temperatures may be varied to suit the installation requirements.

### 5. CHECKOUT

Put the system into operation and observe at least one complete cycle to make sure that the controller operates properly. See Troubleshooting Section to use LED to assist in determining system operation.

### F. CHECK OIL BURNER BEFORE STARTING.

1. CHECK BURNER SETTINGS and readjust if necessary, see Burner Specifications, Table 7-1.

### 2. BECKETT AFG BURNERS

This Beckett AFG burner is equipped with a non-adjustable Fixed "F" Series Head, the number is stamped on the head.

- a. Remove Gun Assembly.
- b. Verify nozzle size, head size, gun setting, and positioning of electrodes. This information is shown in Figure 7-2, and Beckett Burner Specifications, Table 6. Replace Gun Assembly.
- c. Check burner air band and air shutter settings. Readjust if necessary, see Burner Specifications Table 7-1.
- d. OPEN ALL OIL LINE VALVES.
- e. Attach a plastic hose to fuel pump vent fitting and provide a pan to catch the oil.
- f. OPEN FLAME OBSERVATION PORT COVER on burner swing door.

**Table 7-1: Beckett AFG Burners**

Boiler Model	Firing Rate (GPH)	Nozzle	Air		Settings	
			Shutter	Band	Head (stop screw)	Pump Pressure
*AP-110U-N(T)	0.75	0.65 - 80°AB Danfoss	7	0	N/A	140
AP-154U-N(T)	1.10	0.90 - 80°B HAGO	6	0	N/A	140

\* Equipped with low firing rate baffle

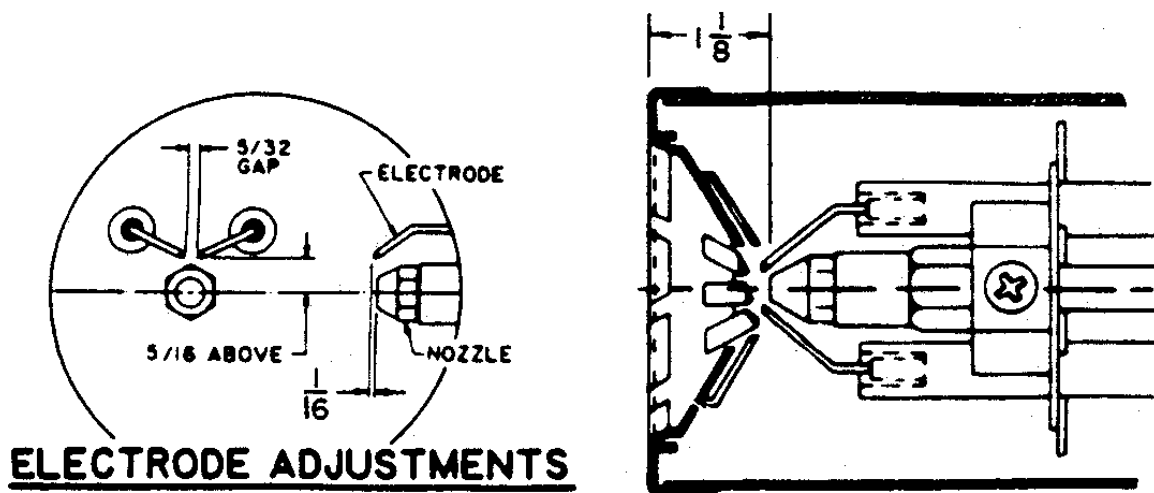
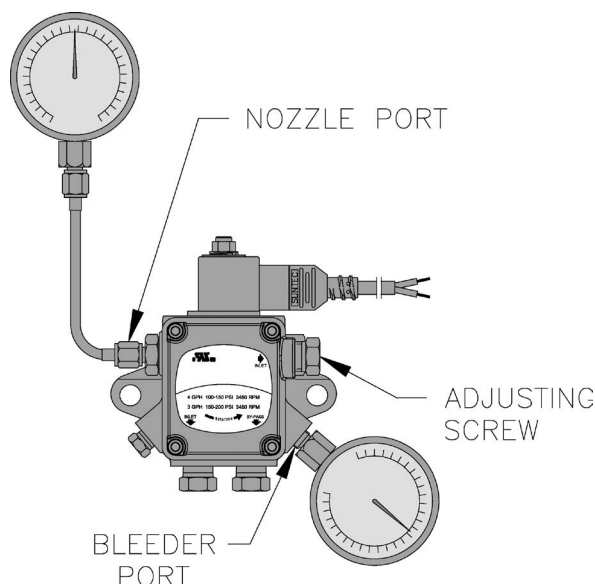

**Figure 7-2: Electrode / Head Setting**

## 7 System Start-Up *(continued)*

### G. START OIL BURNER.

1. Open vent fitting on fuel pump.
2. TURN 'ON' BURNER service switch and allow burner to run until oil flows from vent fitting in a SOLID stream without air bubbles for approximately 10 seconds.
3. Close vent fitting and burner flame should start immediately after prepurge is completed. Prepurge prevents burner flame until 10 seconds has elapsed after initial power is applied to burner. During prepurge the motor and igniter will operate but the oil valve will remain closed. Refer to Oil Primary Control Instructions for more details.
4. Adjust oil pressure.
  - a. When checking a fuel unit's operating pressure, a reliable pressure gauge may be installed in either the bleeder port or the nozzle port. For Beckett burner refer to Figure 7-3.
  - b. Locate oil pressure adjusting screw and turn screw to obtain proper pump pressure, refer to Table 7-1.
  - c. To check the cutoff pressure, deadhead a reliable pressure gauge onto the copper connector tube attached to the nozzle port. Run the burner for a short period of time. Shut the burner off. The pressure should drop and hold.
  - d. Remove the gauge and install bleeder port and/or reconnect the nozzle port line.



**Figure 7-3: Adjusting Fuel Pump Pressure**

### **⚠ WARNING**

DO NOT loosen or remove any oil line fittings while burner is operating.

### H. ADJUST OIL BURNER WHILE OPERATING. (flame present)

1. SET ROOM THERMOSTAT about 10°F below room temperature.
2. PRESS RED RESET BUTTON on Oil Primary Control and release.
3. READJUST THE AIR DAMPER SETTING (air Band/Air Shutter/Air Gate) on the burner for a light orange colored flame while the draft over the fire is -0.02 in. Use a smoke tester and adjust air for minimum smoke (not to exceed #1) with a minimum of excess air. Make final check using suitable instrumentation to obtain a CO<sub>2</sub> of 11.5 to 13.0% with draft of -0.02" (water gauge) in fire box. These settings will assure a safe and efficient operating condition. If the flame appears stringy instead of a solid fire, try another nozzle of the same type. Flame should be solid and compact. After all adjustments are made, recheck for a draft of -0.02" over the fire.
4. ADJUST DRAFT REGULATOR for a draft of -0.02" (water gauge) over the fire after chimney has reached operating temperature and while burner is running.
5. FLAME FAILURE

The AP-U boiler controls operate the burner automatically. If for unknown reasons the burner ceases to fire and the reset button on the primary control has tripped, the burner has experienced ignition failure. Refer to Oil Primary Control features, Paragraph J, Step 2 of this section and Section 11, Troubleshooting, Paragraph B. If the failure re-occurs, call your heating contractor immediately before pressing the reset button.

### **⚠ WARNING**

DO NOT attempt to start the burner when excess oil has accumulated, when the boiler is full of vapor, or when the combustion chamber is very hot.

### 6. CAD CELL LOCATION AND SERVICE

The burner is supplied with a cadmium sulfide flame detector mounted at the factory,

## 7 System Start-Up *(continued)*

mounted on the bottom of the electronic ignitor. See Figure 7-4. To service cad cell or to replace the plug in portion, swing open the ignitor. After service is complete, be sure to fasten down the ignitor.

### I. CHECK FOR CLEAN CUT OFF OF BURNER.

1. AIR IN THE OIL LINE between fuel unit and nozzle will compress when burner is on and will expand when burner stops, causing oil to squirt from nozzle at low pressure as burner slows down and causing nozzle to drip after burner stops. Usually cycling the burner operation about 5 to 10 times will rid oil line of this air.

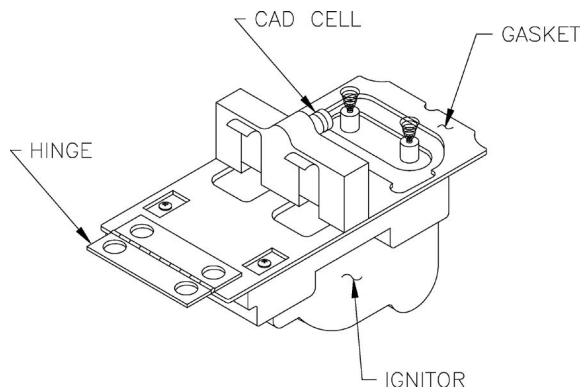

**Figure 7-4: Cad Cell Location**

2. IF NOZZLE CONTINUES TO DRIP, repeat Paragraph H, Step 1 above. If this does not stop the dripping, remove cut-off valve and seat, and wipe both with a clean cloth until clean, then replace and readjust oil pressure. If dripping or after burn persist replace fuel pump.

### J. TEST CONTROLS

1. Check thermostat operation. Raise and lower thermostat setting as required to start and stop burner.

#### **WARNING**

Before installation of the boiler is considered complete, the operation of all boiler controls must be checked, particularly the primary control and high limit control.

2. VERIFY OIL PRIMARY CONTROL FEATURES using procedures outlined in Instructions furnished with control or instructions as follows:

- a. **GeniSys 7505 Control Features**, see Figure 7-5.
  - i. The GeniSys 7505 is a microprocessor-based control. The indicator light provides diagnostic information for

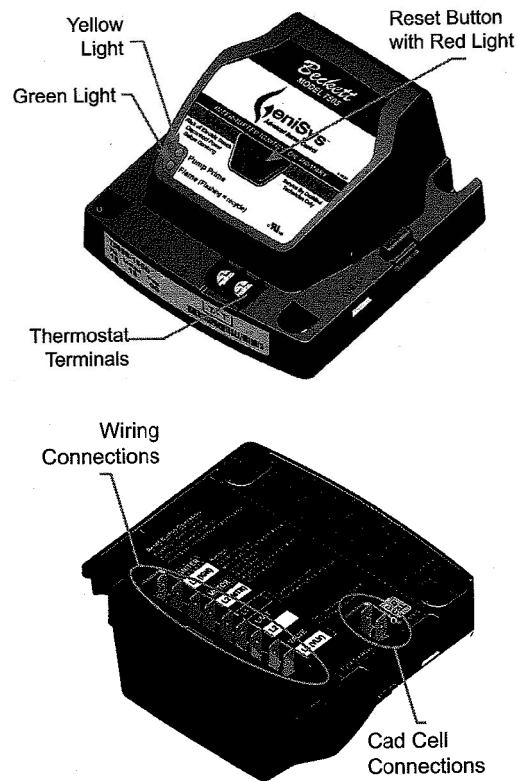

**Figure 7-5: GeniSys 7505 Oil Primary Terminals, LED's and Reset Button**

lockout, recycling and cad cell status. There is a manual reset button to exit the Lockout Mode.

- ii. Pump Priming Cycle: To facilitate purging air from the oil lines and filters, the 7505 can be placed in a purge routine by:
  - After the burner starts, press and hold the reset button for 15 seconds until the yellow light turns on. This indicates that the button has been held long enough.
  - Release the reset button. The yellow light will turn off and the burner will start up again.
  - At burner start up, click the reset button while the igniter is still on. This will transition the control to a dedicated Pump Prime mode, during which the motor, igniter, and valve are powered for four (4) minutes. The yellow light will be on.
  - At the end of four (4) minutes, the yellow light will turn off and the control will automatically return to standby mode.

## 7 System Start-Up *(continued)*

- iii. Limited Recycle: This feature limits the number of recycle trials (for each call for heat) to a maximum of three trials. If the flame is lost three times and does not successfully satisfy a call for heat, the 7505 locks out.
- iv. Limited Reset (Restricted Mode): In order to limit the accumulation of unburned oil in the combustion area, the control can only be reset three times. The reset count returns to zero each time a call for heat is successfully completed.
- v. T-T Jumper: Select models have pre-installed T-T jumper. **DO NOT** remove jumper.

**Note: DO NOT** remove "T-T" jumper **unless** wiring diagram indicates a direct connection from thermostat and/or tankless heater aquastat control to the oil burner primary control's "T-T" terminal. Refer to appropriate wiring diagram, see Figure 5-1.

- vi. Diagnostic LED: The indicator light on oil primary control provides lockout, recycle and cad cell indications as follows:
  - Flashing at 1 Hz (½ second on, ½ second off): system is locked out or in Restricted Mode.
  - Flashing at ¼ Hz (2 seconds on, 2 seconds off): control is in Recycle Mode.
  - On: cad cell is sensing flame.
  - Off: cad cell is not sensing flame.
- vii. Cad Cell Resistance Check: For proper operation it is important that the cad cell resistance is below 1600 ohms. During a normal call for heat, the cad cell leads can be unplugged from the control and the resistance measured with a meter in the conventional way. Conduct these tests with flame present, see chart below.

Flame Detection Range
Normal (0 - 1600 ohms)
Limited (1600 ohms to lockout)

### 3. CHECK OIL PRIMARY CONTROL

#### CAUTION

Due to the potential hazard of line voltage, only a trained, experienced service technician should perform the following safety checks.

This control contains no field-serviceable parts. **DO NOT** attempt to take it apart. Replace entire control if operation is not as described.

#### a. Preliminary Steps

- Check wiring connections and power supply.
- Make sure power is on to the controls.
- Make sure limit control is closed.
- Check contacts between ignitor and the electrodes.
- Check the oil pump pressure.
- Check the piping to the oil tank.
- Check the oil nozzle, oil supply and oil filter.

#### b. Check Safety Features

Safe Start:

- Place a jumper across cad cell terminals.
- Follow procedure to turn on burner. Burner must not start, indicator light turns on and control remains in Idle Mode.
- Remove jumper.

#### c. Simulate Ignition or Flame Failure:

- Follow procedure to turn on burner.
- Check cad cell resistance. If resistance is below 1600 OHMS and burner runs beyond safety cut-out time, cad cell is good.
- If safety switch shuts down burner and resistance is above 1600 OHMS, open line switch to boiler. Access cad cell under ignitor, clean face of cad cell and see that cell is securely in socket. Check gasket around perimeter of ignitor lid for proper seal. If gasket is missing or damaged, replace gasket. Room light can effect cad cell resistance. Reset safety switch.
- Close line switch to boiler. If burner starts and runs beyond safety switch cut-off time, cell is good. If not, install new cell.
- Close hand valve in oil supply line.

## 7 System Start-Up *(continued)*

- Failure occurs, device enters Recycle Mode.
  - Device tries to restart system after approximately 60 seconds.
  - After third Recycle Mode trial, safety switch locks out within safety switch timing indicated on label and control enters Restricted Mode. Ignition and motor stop and oil valves closes.
- d. Power Failure Check: After Flame is established, turn the power off to the control/burner. The burner should shut down safely. When power is restored a normal ignition sequence should be started.

### **WARNING**

Cad Cell Jumper must be removed after this check.

4. CHECK HIGH LIMIT
- a. Adjust system thermostat(s) to highest setting.
  - b. Allow burner to run until boiler water temperature exceeds high limit setting. The burner should shut down and circulators continue running.
  - c. Allow the temperature to drop below control setting. The burner must restart.
  - d. Boiler installation is not considered complete until this check has been made.
5. CHECK OPERATING CONTROL on boiler applications equipped with tankless heater(s). With burner off, draw hot water until burner starts, then turn off hot water and check burner shut-down.
- K. IF CONTROLS MEET REQUIREMENT outlined in Paragraph I.
- 1. Allow boiler to operate for approximately 30 minute, confirm the boiler and system have no leaks.
- L. IF CONTROLS DO NOT MEET REQUIREMENTS outlined in Paragraphs I-1 thru I-6, replace control and repeat checkout procedures.
- M. Boiler is now ready to be put into service.

## 8 Operating

- A. Setting the High Limit: The high limit is factory set at 190°F. To adjust, turn the HI TEMP Dial A until the desired setting is displayed. (Setting range: 100°-220°F).
- B. Setting the Low Limit: The low limit is designed to maintain temperature in boilers equipped with tankless coils used for domestic hot water. The low limit is factory set to OFF. Prior to adjusting, remove the jumper (not equipped on all units) B. Then turn the LP TEMP Dial C clockwise until the desired temperature is displayed. For proper operation, the low temperature limit setting should be least 10° below the high limit setting. NOTE: For cold start operation, the low limit must be turned OFF. IMPORTANT: If low limit temperature cannot be set above 140°F, remove jumper B. (Setting range: OFF or 110° -200° F).
- C. Setting the Economy Feature: The Economy Feature is factory set for a 1 zone heating system. To adjust, turn the ECONOMY Dial D until the number displayed equals the number of heating zones. Do not include indirect water heaters in the number of heating zones. The Economy Feature conserves fuel by reducing boiler temperature (see "How Thermal Targeting Works". If the heating system is unable to supply needed heat to the house, the ECONOMY Dial should be turned to a lower setting (example: In a three zone house, turn the dial to 2 or 1.) Conversely, if the boiler provides adequate heat, added fuel savings can be achieved by selecting a higher setting (example: 4 or 5). If the heating and indirect water heater signals were not separated when wiring the control, the Economy Feature should be turned OFF to ensure the boiler supplies adequate temperature to heat the indirect tank.
- D. Setting the Zone/Indirect Switch: See WIRING.

Setting	
Off	Disables economy function. Will allow boiler to fire until hi-limit temp is reached and re-fire with a 10° subtractive differential
LO	Provides lowest level of fuel savings. Use this setting only if the house does not stay warm at higher settings.
1	Recommended setting for single zone systems
2	Recommended setting for Two zone systems
3	Recommended setting for Three zone systems
4	Recommended setting for Four zone systems
5	Recommended setting for Five zone systems
HI	Provides highest level of fuel savings

- E. Optional Features: NOTE: The Program Mode - Pro - is accessed by turning the LO TEMP dial to a position just above OFF.
1. Thermal Pre-Purge: Thermal Pre-Purge is designed to maximize boiler efficiency. When activated, the control

will supply latent heat that may remain in the boiler from a previous run cycle to the heating zone that is now calling. The control monitors how quickly the boiler temperature is declining and activates the burner only when it determines that the latent heat is insufficient to satisfy the call. During the purge cycle, the display will indicate Pur. This feature works with single-zone and multi-zone heating systems utilizing circulators or zone valves. No change in wiring is needed.

### To activate Thermal Pre-Purge

1. Turn the LO TEMP dial to access the Program Mode - indicated in the display as Pro
  2. Turn the HI TEMP dial to select feature 1
  3. Push the Test/Setting Button to turn Thermal Pre-Purge ON or OFF
  4. Reset LO TEMP and HI TEMP settings to desired temperatures.
2. Degrees Fahrenheit or Celsius: The control has the ability to operate in degrees Fahrenheit or Celsius. When operating in Celsius, a c will appear in the display next to the temperature when ever the temperature is below 100 degrees.

### To change between degrees Fahrenheit and degrees Celsius

1. Turn the LO TEMP dial to access the Program Mode - indicated in the display as Pro
  2. Turn the HI TEMP dial to select feature 2
  3. Push the Test/Setting Button to c for Celsius or F for Fahrenheit
  4. Reset LO TEMP and HI TEMP settings to desired temperatures.
3. Manual Reset Low Water Cut-Off: The low water cut-off operation on the HydroStat can be set to operate in automatic (default) or manual reset mode. When in manual reset mode, the control will shut-down the burner immediately when low water condition is detected. If the low water condition is sustained for 30 seconds, the low water light will blink, indicating that the control has locked out the burner. The control can only be reset by pushing the Test Settings button on the top of the control. The manual reset feature meets CSD-1 code requirements.

**IMPORTANT:** The system must be checked by a qualified heating professional prior to resuming operation.

**WARNING: DO NOT ADD WATER UNTIL THE**

## 8 Operating *(continued)*

### BOILER HAS FULLY COOLED.

#### *To activate Manual Reset LWCO mode*

1. Turn the LO TEMP dial to access the Program Mode - indicated in the display as Pro
2. Turn the HI TEMP dial to select feature 3
3. Push the Test/Setting Button to A for Automatic Reset Mode
4. Reset LO TEMP and HI TEMP settings to desired temperatures.

*To Test the Manual Reset Feature:* Press and hold the Test/Settings button located on the top of the control for 30 seconds to simulate a low water condition. After 30 seconds, the Low Water light will blink indicating that the control is locked out. To reset the lock-out condition, press the Test/Setting button momentarily.

#### 4. Circulator Activation Options

When in the default mode, the HydroStat activates the circulator (**C1/C2** contacts) on calls to **TT**. The control can be programmed to activate the circulator on calls to **ZC/ZR** in place of, or in addition to **TT**.

#### *To change how the Circulator is activated*

1. Turn the LO TEMP dial to access the Program Mode - indicated in the display as Pro
2. Turn the HI TEMP dial to select feature 4
3. Push the Test/Setting Button to select between the following options:  
A - Circulator on **TT** call only  
b - Circulator on **ZC/ZR** calls  
C - Circulator on both **TT** & **ZC/ZR** calls
4. Reset LO TEMP and HI TEMP settings to desired temperatures.

#### 5. Circulator Hold Off (Enhanced Condensing Protection)

To reduce the potential for condensing, On a call for heat the control will allow the boiler to heat to 125°F prior to energizing the circulator. Once energized, the circulator will remain on for the duration of the heating call unless the boiler temperature drops below 115°F. If this occurs, the circulator will re-energize when the boiler returns to 125°F. Circulator Hold Off will expire after 15 minutes.

#### *To activate Circulator Hold Off*

1. Turn the LO TEMP dial to access the Program Mode - indicated in the display as Pro
2. Turn the HI TEMP dial to select feature 5
3. Push the Test/Setting Button to Circulator Hold Off ON or OFF
4. Reset LO TEMP and HI TEMP settings to desired temperatures.

#### 6. *Setting the Well Type (Electro-Well vs.*

#### *Standard Immersion Well)*

When used to replace older temperature-only controls, the HydroStat can be installed on the existing well. (The Hydrolevel Electro-Well is required to activate low water cut-off operation. Older wells may contain hardened heat transfer grease or other contaminants that could interfere with metal-to-metal continually between the sensor head and the inside of the well. Insufficient contact could lead to false low water conditions and burner shut downs. Setting the well type to Standard Well prevents the possibility of this occurring.

#### *To change the well type*

1. Turn the LO TEMP dial to access the Program Mode - indicated in the display as Pro
2. Turn the HI TEMP dial to select feature 8
3. Push the Test/Setting Button to select A for Electro-Well or b for Standard Well.

NOTE: To ensure that the low water cut-off is always active when the control is installed on an Electro-Well, setting b will ONLY be available when installed on a standard well. The HydroStat sensor checks to determine if a standard well is used by looking for low resistance to ground, a condition that can only exist with a standard well. If you are installing on a standard well and either Low Water LED's are on, setting b will not be available. Check to see if the inside of the well tube is badly oxidized or contaminated with heat transfer grease. It may be necessary to clean the well to allow for setting b to be selected (See Troubleshooting Guide for more information).

#### 7. *High Limit Differential*

When the Economy feature is on, the control's Thermal Targeting feature actively sets varying differentials based on system conditions. This option allows for selecting a 10, 20 or 30 degree fixed differential when the Economy feature is turned OFF. These optional differential settings are subtractive from the HIGH LIMIT setting. **Note:** If the Economy feature is on, this setting will be overridden by the control's Thermal Targeting function.

#### *To change the high limit differential*

1. Turn the LO TEMP dial to access the Program Mode - indicated in the display as Pro
2. Turn the HI TEMP dial to select feature 9
3. Push the Test/Setting Button to select a high limit differential of 10, 20, or 30
4. Reset LO TEMP and HI TEMP settings to desired temperatures.
8. Restore Factory Default Settings

## 8 Operating *(continued)*

Dial Setting	Feature	Options	Description	Default Setting
1	Thermal Pre-Prurge	OFF ON	Purge Inactive Purge Active	OFF
2	Fahrenheit or Celsius	F C	Degrees Fahrenheit Degree Celcius	F
3	LWCO Manual or Automatic Reset	A b	Automatic Reset Manual Reset	A
4	Circulator Options	A b c	Circulator operation on TT call only Circulator operation on ZC/ZR call only Circulator operation on call from either	A
5	Circulator Hold Off	ON OFF	Circulator Hold Off - Active Circulator Hold Off - Inactive	ON
6	Not available on this control			
7	Not available on this control			
8	Well Type	A b	Hydrolevel Electro-Well Standard Immersion Well	A
9	High Limit Differential	10 20 30	10° Differential 20° Differential 30° Differential	10
dEF	Restore Factory Defaults	Y N	Restore Defaults Do Not Restore Defaults	n

**NOTE:** If the HydroStat is factory-equipped on a boiler, some options may be set differently from the default settings. Not all features are available on older HydroStat models.

*To restore all features to the factory default settings (see following chart for default settings)*

1. Turn the LO TEMP dial to access the Program Mode - indicated in the display as Pro
2. Turn the HI TEMP dial to select feature dEF
3. Push the Test/Setting Button to Y to reset all features to the default settings
4. Reset LO TEMP and HI TEMP settings to desired temperatures.
9. LED Legend and Test/Settings Button
  - a. TEMP ACTIVE Indicates that the Fuel Smart HydroStat control is powered and that the temperature function is active.
  - b. TEMP HI TEMP Illuminates when the boiler water temperature reaches the high limit setting. It will remain lit until the water temperature falls 10°. The Fuel Smart HydroStat prevents burner operation while this LED is on. See Differential explanation.
  - c. LWCO ACTIVE Indicates that the low

water cut-off (LWCO) function of the Fuel Smart HydroStat is active. When the control is installed with a Hydrolevel Electro-Well™, this LED will be on at all times when the control is powered. **IMPORTANT:** If the control is installed with a well other than the Elctro-Well™, this LED will no illuminate indicating that the control is not providing low water cut-off functionality.

- d. LWCO LOW WATER Indicates that the boiler is in a low water condition. The HydroStat control will prevent burner operation during this condition. If the LOW WATER light is blinking, the control has been programmed to provide lockout protection in the event a low water condition is detected (see Manual Reset Low Water Cut-Off). Pressing the TEST/SETTINGS button will reset the control.

**IMPORTANT:** The system must be checked by a qualified heating professional prior to resuming operation.

## 8 Operating *(continued)*

### WARNING

Allow the boiler to fully cool before adding water.

- e. **ECONOMY ACTIVE** Indicates that the Thermal Targeting function is active and the Fuel Smart HydroStat will reduce boiler temperature to conserve fuel. The Economy feature is activated using the ECONOMY dial. (See “How Thermal Targeting Works” for more information).
- f. **ECONOMY TARGET** When the Economy feature is active, the Fuel Smart HydroStat continually sets target temperature below the high limit setting to maximize fuel efficiency. When the boiler water reaches the target temperature, the LED illuminates and the burner will shut down. The boiler water will continue to circulate and heat the house as long as the thermostat call continues. The LED will stay lit until the boiler temperature drops below the differential set point at which point the boiler will be allowed to fire again. See Differential explanation.
 

**NOTE:** This LED illuminates regularly during normal boiler operation.
- g. **TEST/TESTING Button**  
**To Test Low Water Cut-Off:** Press and hold the Test/Settings button for 5 seconds. The display will read LCO.

### LWCO TEST LCO

The red Low Water light should illuminate and the burner circuit (B1 and B2) should de-energize.

**NOTE:** The control must be installed with a Hydrolevel Electro-Well™ for low water cut-off functionality.

**To View Current Settings:** Press and release the Test/Settings Button in short intervals to sequentially display the following settings:

HIGH LIMIT SETTING HL



LOW LIMIT SETTING LL



ECONOMY SETTING ECO



CURRENT TARGET TEMPERATURE 000

The display will return to boiler temperature (default) if Test/Settings Button is not pressed for 5 seconds.

## 9 Maintenance & Service Instructions

### A. WATER BOILERS:

#### 1. Filling of boiler and system.

GENERAL — In a hot water heating system, the boiler and entire system (other than the expansion tank) must be full of water for satisfactory operation. Water should be added to the system until the boiler pressure gauge registers 12 psi. To insure that the system is full, water should come out of all air vents when opened.

#### 2. BOILING OUT OF BOILER AND SYSTEM. The oil and grease which accumulate in a new hot water boiler can be washed out in the following manner:

- a. Remove relief valve using extreme care to avoid damaging it.
- b. Add an appropriate amount of recommended boil out compound.
- c. Replace relief valve.
- d. Fill the entire system with water.
- e. Start firing the boiler.
- f. Circulate the water through the entire system.
- g. Vent the system, including the radiation.
- h. Allow boiler water to reach operating temperature, if possible.
- i. Continue to circulate the water for a few hours.
- j. Stop firing the boiler.
- k. Drain the system in a manner and to a location that hot water can be discharged with safety.
- l. Remove plugs from all available returns and wash the water side of the boiler as thoroughly as possible, using a high-pressure water stream.

m. Refill the system with fresh water.

#### 3. Add appropriate boiler water treatment compounds as recommended by your qualified water treatment company.

#### 4. Make pH or Alkalinity Test.

After boiler and system have been cleaned and refilled as previously described, test the pH of the water in the system. This can easily be done by drawing a small sample of boiler water and testing with hydron paper which is used in the same manner as litmus paper, except it gives specific readings. A color chart on the side of the small hydron dispenser gives the reading pH. Hydron paper is inexpensive and obtainable from any chemical

supply house or through your local druggist. The pH should be higher than 7 but lower than 11. Add some of the washout chemical (caustic soda), if necessary, to bring the pH within the specified range.

#### 5. Boiler is now ready to be put into service.

### B. EXCESSIVE MAKE-UP WATER

A leaky system will increase the volume of make-up water supplied to the boiler, which can significantly shorten the life of the boiler. Entrained in make-up water are dissolved minerals, salts and oxygen. When the fresh, cool make-up water is heated in the boiler, the minerals fall out as sediment, the salts coat the inside of the boiler, and the oxygen escapes as a gas. The accumulation of sediment eventually isolates the water from contacting the steel. When this happens the steel in that area gets extremely hot and eventually cracks. The presence of free oxygen or chloride salts in the boiler creates a corrosive atmosphere which, if the concentration becomes high enough, can corrode the steel through from the inside. More make-up water and higher concentrations of contaminants damage the boiler sooner. Our warranty does not cover corrosion and sediment-related damage. Clearly it is in everyone's best interest to prevent this type of failure. You can do your part by ensuring that your system is leak-free, keeping leakage to less than 2 percent of the total water volume each month. Refer to Chart below.

### IMPORTANT

IF, DURING NORMAL OPERATION, IT IS NECESSARY TO ADD MORE WATER THAN INDICATED BELOW, CONSULT A QUALIFIED SERVICE TECHNICIAN TO CHECK YOUR SYSTEM FOR LEAKS.

Model No.	Gallons Per Month	Gallons Per Year
AP-110U-N(T)	0.2	3
AP-154U-N(T)	0.3	4

### C. ATTENTION TO BOILER WHILE NOT IN OPERATION

#### 1. IMPORTANT

IF BOILER IS NOT USED DURING WINTER TIME, IT MUST BE FULLY DRAINED TO PREVENT FREEZE DAMAGE.

2. Spray inside surfaces with light lubricating or crankcase oil using gun with extended stem so as to reach all corners.

## 9 Maintenance & Service Instructions *(continued)*

3. With steam boilers, at end of season add sufficient water to fill boiler to top of water column and leave it that way until fall when water should be drained again to proper level. If, at this time, boiler water is dirty, drain water, flush out boiler, and refill with clean water to prescribed water level.
4. Always keep the manual fuel supply valve shut off if the burner is shut down for an extended period of time.
5. To recondition the heating system in the fall season after a prolonged shut down, follow the instructions outlined in Section 7, System Start-Up, Paragraphs A through M.

### WARNING

This boiler contains controls which may cause the boiler to shut down and not restart without service. If damage due to frozen pipes is a possibility, the heating system should not be left unattended in cold weather; or appropriate safeguards and alarms should be installed on the heating system to prevent damage if the boiler is inoperative.

## 10 Boiler Cleaning

**NOTICE:** BURNER SHUTDOWN: Open Service Switch to turn off burner.

Manual Oil Supply Valve should be closed and Electric Service to boiler turned off if boiler will not be operated for an extended period of time.

- A. GENERAL. Inspection service and cleaning should be conducted annually. Turn off electric power and close oil supply valve while conducting service or maintenance.
- B. FIRETUBES AND COMBUSTION CHAMBER. (See Figure 10-1)
  1. CLEAN THE FIRETUBES
    - a. Disconnect electric to burner and remove stack.

- b. For access to the firetubes, pull top jacket panel off. Remove brass nuts, that hold canopy down. Without taking off carriage bolts, pull canopy off.
- c. Remove turbulators.
- d. Using a firetube brush clean firetubes. DO NOT extend brush past the end of the bottom tubesheet.
- e. Assemble the boiler in reverse order.

Units should be cleaned at least once a year, preferably at the end of each heating season. It is not necessary to remove burner to clean boiler.

Brush, scrape, or vacuum from top.

# 10 Boiler Cleaning *(continued)*

**Note:** Units should be cleaned at least once a year, preferably at the end of each heating season.

It is not necessary to remove burner to clean boiler.

Brush, scrape or vacuum clean flue tubes carefully from top without extending cleaning tools beyond bottom of flue tubes to prevent damage to combustion chamber.

## CAUTION

Combustion chamber is a lightweight ceramic type. do not extend cleaning tools beyond bottom of flue tubes to prevent damage to combustion chamber.

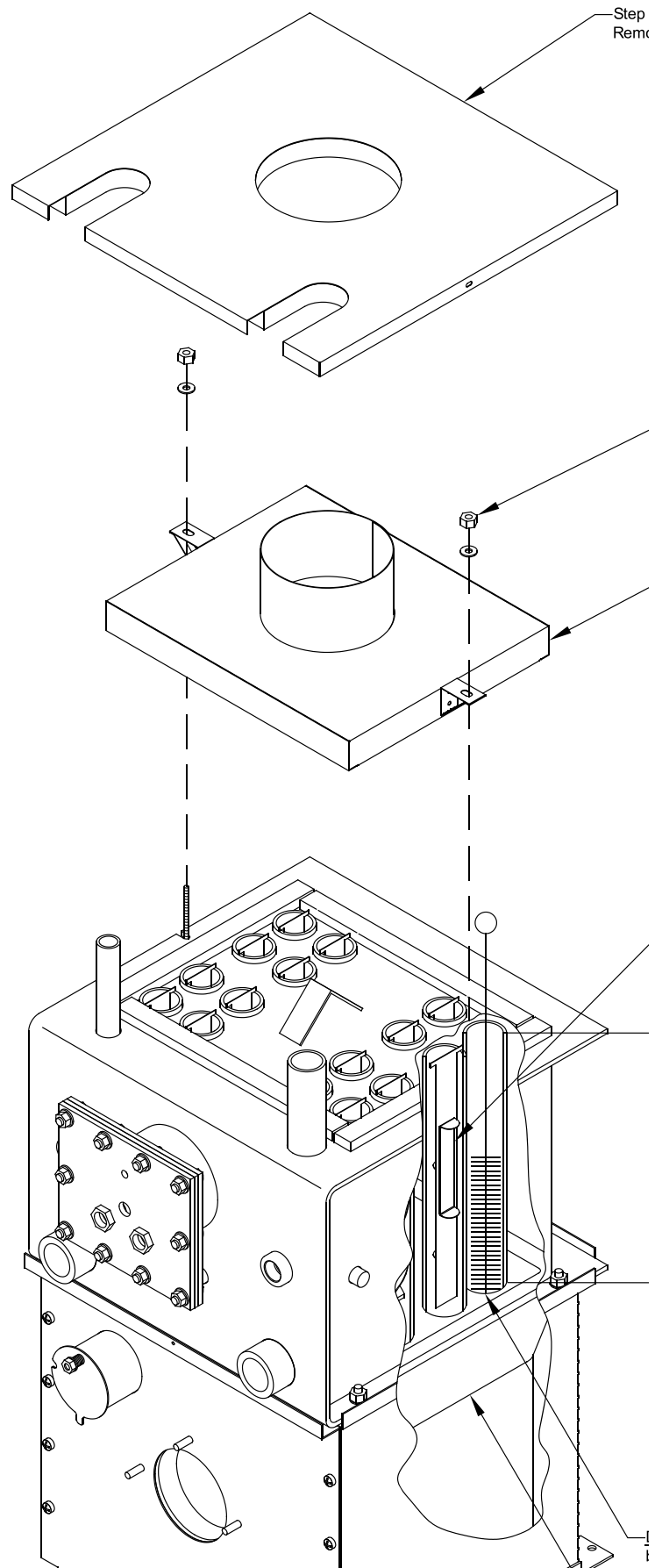

**Table 10-2**

Boiler Model	Dimension "X"
AP-110U-N(T)	13 3/8
AP-154U-N(T)	19 7/8

**Figure 10-1: Cleaning of AP-U Boiler**

## 10 Boiler Cleaning *(continued)*

### Important Product Safety Information: Refractory Ceramic Fiber Product

#### WARNING

Some boiler components use materials that contain refractory ceramic fibers (RCF). RCF has been classified as a possible human carcinogen. When exposed to elevated temperatures, RCF may change into crystalline silica, a known carcinogen. When disturbed as a result of servicing or repair, these substances become airborne and, if inhaled, may be hazardous to your health. Avoid breathing RCF particulates and dust.

#### Precautionary Measures:

- Do not handle RCF parts or attempt any service or repair work involving RCF without wearing the following protective gear:
  1. A properly fitting National Institute for Occupational Safety and Health (NIOSH)-certified air-purifying respirator with a filter efficiency of at least 95%. Respirator should also include a full facepiece when handling used RCF. Other types of respirators may be required depending on site conditions. Current NIOSH recommendations may be found on the NIOSH website <http://www.cdc.gov/niosh/homepage.html>. NIOSH-approved manufacturers, respirators and associated user instructions are listed on the NIOSH website.
  2. Long sleeved, loose fitting clothing that is sufficiently tight around potential entry points for RCF dust.
  3. Gloves.
  4. Eye protection, such as goggles, safety glasses with side shields, or full facepiece.
- Take steps to assure adequate ventilation.
- Handle RCF carefully to minimize airborne dust. Use hand tools whenever possible.
- Dampen used RCF with light water spray prior to removal to prevent airborne dust.
- Do not use compressed air or dry sweeping for clean-up. Frequently clean work area with a vacuum or by wet sweeping to minimize debris accumulation.
- Vacuum work clothes before leaving work area. Wash work clothes separately from other laundry and rinse washing machine after use to avoid contaminating other clothes.
- Wash all exposed body areas gently with soap and water after contact.
- Discard used RCF components by sealing in an airtight plastic bag or container. Refer to local, regional, state or provincial regulations to identify applicable disposal requirements.

#### First Aid Procedures:

- Eye contact: Flush with water for at least 15 minutes. **Do not rub eyes.** Seek immediate medical attention if irritation persists.
- Skin contact: Wash affected area gently with soap and water. Do not rub or scratch affected skin. Seek immediate medical attention if irritation persists.
- Nose and throat contact: If these become irritated, leave the area and move to a location with clean fresh air. Drink water and blow nose. Seek immediate medical attention if symptoms persist.

# 11 Troubleshooting

## A. COMBUSTION

1. **NOZZLES** — Although the nozzle is a relatively inexpensive device, its function is critical to the successful operation of the oil burner. The selection of the nozzle supplied with the AP-U boiler is the result of extensive testing to obtain the best flame shape and efficient combustion. Other brands of the same spray angle and spray pattern may be used but may not perform at the expected level of CO<sub>2</sub> and smoke. Nozzles are delicate and should be protected from dirt and abuse. Nozzles are mass-produced and can vary from sample to sample. For all of those reasons a spare nozzle is a desirable item for a serviceman to have.
2. **FUEL LEAKS** — Any fuel leak between the pump and the nozzle will be detrimental to good combustion results. Look for wet surfaces in the air tube, under the ignitor, and around the air inlet. Any such leaks should be repaired as they may cause erratic burning of the fuel and in the extreme case may become a fire hazard.
3. **SUCTION LINE LEAKS** — Any such leaks should be repaired, as they may cause erratic burning of the fuel and in extreme cases may become a fire hazard. Whatever it takes, The Oil Must Be Free of Air. This can be a tough problem, but it must be resolved. Try bleeding the pump through a clear tube. There must be no froth visible. There are various test kits available to enable you to look at the oil through clear tubing adapted to the supply line at the pump fitting. Air eliminators are on the market that have potential. Also, electronic sight glasses are being used with good success. At times, new tubing must be run to the tank or new fittings put on. Just make sure you get the air out before you leave.  
Any air leaks in the fuel line will cause an unstable flame and may cause delayed ignition noises. Use only flare fittings in the fuel lines.
4. **GASKET LEAKS** — If 11.5 to 12.5% CO<sub>2</sub> with a #1 smoke cannot be obtained in the breeching, look for air leaks around the burner mounting gasket, observation door, and canopy gasket. Such air leaks will cause a lower CO<sub>2</sub> reading in the breeching. The smaller the firing rate the greater effect an air leak can have on CO<sub>2</sub> readings.
5. **DIRT** — A fuel filter is a good investment. Accidental accumulation of dirt in the fuel system can clog the nozzle or nozzle strainer and produce a poor spray pattern from the nozzle. The smaller the firing rate, the smaller the slots become in the nozzle and the more prone to plugging it becomes with the same amount of dirt.
6. **WATER** — Water in the fuel in large amounts will stall the fuel pump. Water in the fuel in smaller amounts will cause excessive wear on the pump, but more importantly water doesn't burn. It chills the flame and causes smoke and unburned fuel to pass out of the combustion chamber and clog the flueways of the boiler.
7. **COLD OIL** — If the oil temperature approaching the fuel pump is 40°F or lower, poor combustion or delayed ignition may result. Cold oil is harder to atomize at the nozzle. Thus, the spray droplets get larger and the flame shape gets longer. An outside fuel tank that is above grade or has fuel lines in a shallow bury is a good candidate for cold oil. The best solution is to locate the tank near the boiler in the basement utility room or bury the tank and lines deep enough to keep the oil above 40°F. Check environmental issues with local authorities having jurisdiction.
8. **FLAME SHAPE** — Looking into the combustion chamber through the observation port, the flame should appear straight with no sparklers rolling up toward the crown of the chamber. If the flame drags to the right or left, sends sparklers upward or makes wet spots on the target wall, the nozzle should be replaced. If the condition persists look for fuel leaks, air leaks, water or dirt in the fuel as described above.
9. **HIGH ALTITUDE INSTALLATIONS** — Air openings must be increased at higher altitudes. Use instruments and set for 11.5 to 12.5% CO<sub>2</sub>.
10. **START-UP NOISE** — Late ignition is the cause of start-up noises. If it occurs recheck for electrode settings, flame shape, air or water in the fuel lines.
11. **SHUT DOWN NOISE** — If the flame runs out of air before it runs out of fuel, an after burn with noise may occur. That may be the result of a faulty cut-off valve in the fuel pump, or it may be air trapped in the nozzle line. It may take several firing cycles for that air to be fully vented through the nozzle. Water in the fuel or poor flame shape can also cause shut down noises.

# 11 Troubleshooting *(continued)*

**NOTICE:** CHECK TEST PROCEDURE. A very good test for isolating fuel side problems is to disconnect the fuel system and with a 24" length of tubing, fire out of an auxiliary five gallon pail of clean, fresh, warm #2 oil from another source. If the burner runs successfully when drawing out of the auxiliary pail then the problem is isolated to the fuel or fuel lines being used on the jobsite.

## B. OIL PRIMARY CONTROL *(Oil Primary)*

1. Burner (Oil Primary) will not come on.
  - a. No power to Oil Primary.
  - b. Oil Primary is in lockout or restricted mode. Press reset button for one (1) second to exit lockout. If control has recycled three times within the same call for heat, it will enter into restricted mode. To reset from restricted mode, refer to Section 7, Paragraph I, Step 2 for details.
  - c. CAD cell seeing light.
  - d. CAD assembly defective.
  - e. Control motor relay is stuck closed (see note below).
2. Burner (control) will light, then shut down after a short time, then restart after one (1) minute.
  - a. CAD cell is defective.
  - b. Air leaking into oil line causing flame out.
  - c. Defective nozzle causing flame to be erratic.
  - d. Excessive airflow or draft causing flame to leave burner head.

- e. Excessive back pressure causing flame to be erratic.
3. Control locks out after Trial For Ignition (TFI).
  - a. No oil to burner.
  - b. Shorted electrodes.
  - c. Nozzle clogged.
  - d. Airflow too high.
  - e. Ignitor module defective.
  - f. CAD cell defective.
  - g. Oil valve stuck open or closed.

**Note:** The Safety Monitoring Circuit (SMC) is designed to provide lockout in the event of a stuck or welded motor relay.

**NOTICE:** If flame is not established within 15 seconds of oil valve actuation (known as Trial For Ignition [TFI]) lockout will occur. Lockout is indicated by a red LED solid-on located on the oil primary control.

Hard Lockout will occur if the Oil Primary Control locks-out three (3) times during a call for heat. This is indicated by red light reset button solid-on.

# 11 Troubleshooting *(continued)*

<b>Burner Will Not Fire</b>	See Flow Chart 1
<b>Burner Will Not Shut Down</b>	See Flow Chart 2
<b>Temperature Display Exceeds High Limit Setting</b>	Under normal operation, boiler temperature will continue to rise after the control shuts off the burner. This condition, known as "thermal stacking", results from hot boiler surfaces continuing to release heat into the boiler water.
<b>No or Insufficient Domestic Hot Water</b>	For boiler equipped with a tankless coil, make sure the low limit setting on the HydroState is set properly. NOTE: If the low limit setting is dialed fully clockwise, it will shut off the low temperature maintenance feature and will function as a cold start control. If installed with an indirect water heater, check that the Zone/Indirect Switch is set in the Indirect (I) position. Verify that the end switch in the relay box controlling the indirect water heater is connected to the ZC/ZR terminals. This will ensure that the domestic water calls are prioritized. (See "Heating and Indirect Water Heater.")
<b>Low Water Light (Red LED) is On or Blinking</b>	<p>WARNING: A low water condition is a serious and potentially dangerous condition. Do not attempt to add water to a hot boiler. Allow the boiler to fully cool before adding water.</p> <p>When Installed on an Electro-Well™</p> <p>When the LOW WATER light is on, this indicates that the control is not detecting water in the boiler. When the LOW WATER light is blinking, this indicates that the control has been programmed to provide low water lock-out protections and is currently locked out (see Manual Reset Low Water Cut-Off). Pressing the TEST/SETTINGS button after the low water condition is resolved will reset the lock-out condition.</p> <ol style="list-style-type: none"> <li>1. If the light is on and the heating system is filled with water, pull the sensor out of the well and inspect it. Make sure that the metal clip is protruding enough to come in contact with the inside of the well tube. Check that the well does not have excessive build-up of heat transfer grease that may interfere with the clip contacting the well.</li> <li>2. Remove well and examine for excessive residue build-up. Clean and re-install.</li> </ol> <p>When Installed on a Standard Immersion Well</p> <p>If either LWCO LED lights are illuminated and the control is installed on a standard immersion well, this is false reading caused by a loss of continuity between the sensor and the inside of the well tube. Follow steps 1 and 2 (above) to ensure that the metal sensor head is making good contact with the inside surface of the copper well.</p>
<b>Boiler Will Not Maintain Low Limit Temperature</b>	Check for overlapping high temperature setting. If the high limit setting is set below the low limit setting, the control will default to the high limit setting and the corresponding high limit differential setting.
<b>House Will Not Get or Stay Warm</b>	<ol style="list-style-type: none"> <li>1. Check for air-bound radiators</li> <li>2. Check thermostat settings including heat anticipator settings (common on non-digital thermostats).</li> <li>3. Check the Economy setting. The Economy feature, much like outdoor reset controls, from average boiler temperature and can slow or, in some cases, prevent the house from coming up to temperature. Move to a lower setting (see "Setting the Economy Feature").</li> </ol>
<b>Circulator Contacts C1 and C2 Not Energized on Call for Heat</b>	Check to see that boiler water is at or above 125°F. On a call for heat, the control will not permit the circulator to operate if the boiler water temperature is below 125°F (see "Circulator Hold Off").
<b>All LED Lights and Temp Display are Blinking</b>	If the LED lights and the temp display are blinking alternately, this indicates the control has sensed a boiler temperature of 250°F. When this occurs, the control pulses the burner relay and then shuts down and lock-out the burner. The system should be analyzed to determine the cause of the overheating condition. Check that the sensor is inserted all the way into the well so it can accurately sense the temperature of the boiler water. Check the load on the burner contacts: If the load exceeds the 7.4 Amp rating, the contacts may have welded. Correct the overloading condition and replace the control before reenergizing the system. If the load on the contacts is below the rating, check system wiring and operation as well as the control's high limit setting. If the cause of the overheating is found and the system is deemed safe, the control can be reset by removing power from the control and then repowering while simultaneously pressing the Test/Settings button on the top of the control. If the cause of the overheating condition is not determined, the control should be replaced.

# 11 Troubleshooting *(continued)*

## Troubleshooting Flow Chart 1 - Burner Will Not Fire

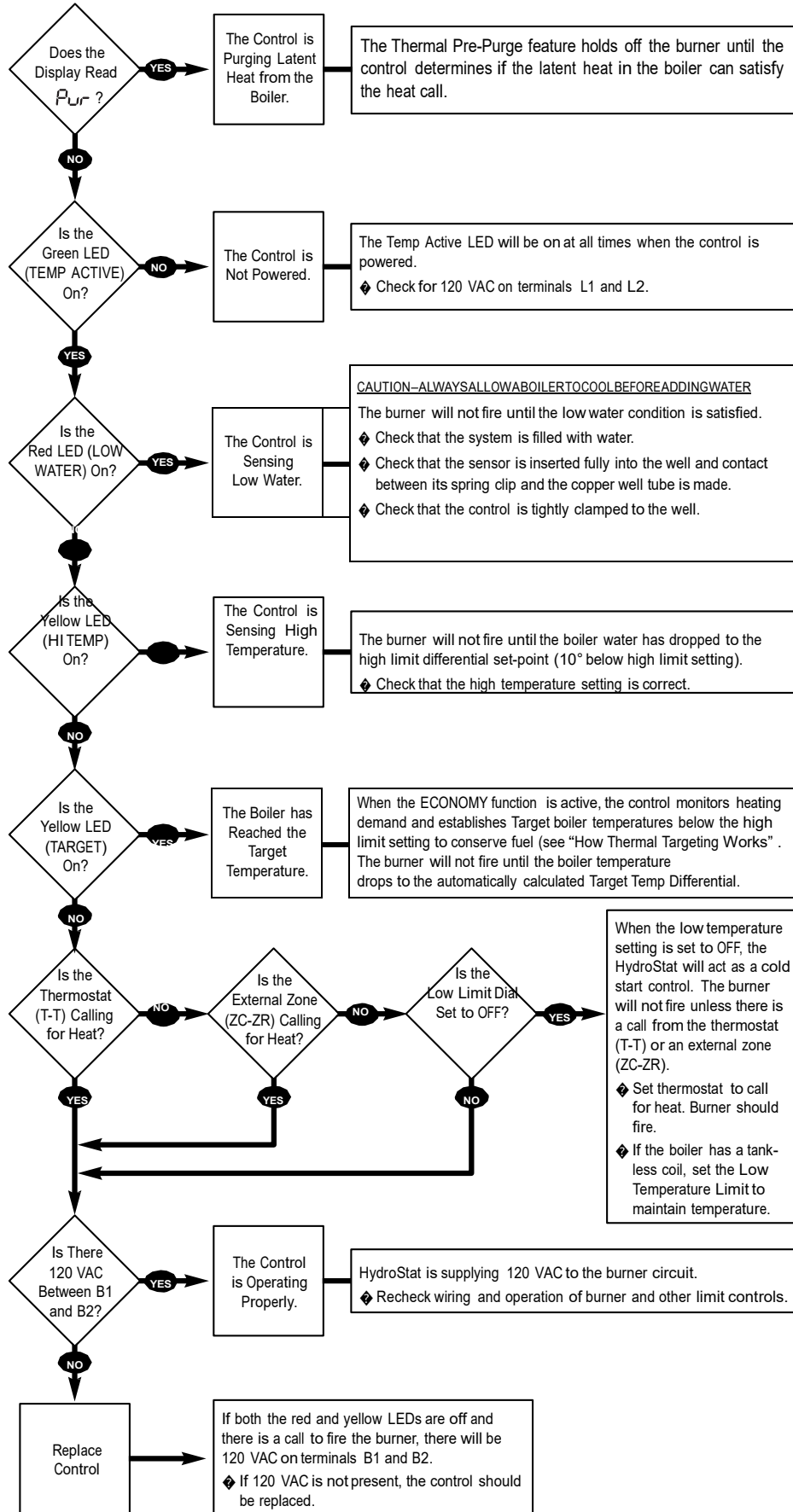

# 11 Troubleshooting *(continued)*

## Troubleshooting Flow Chart 1 - Burner Will Not Shut Down

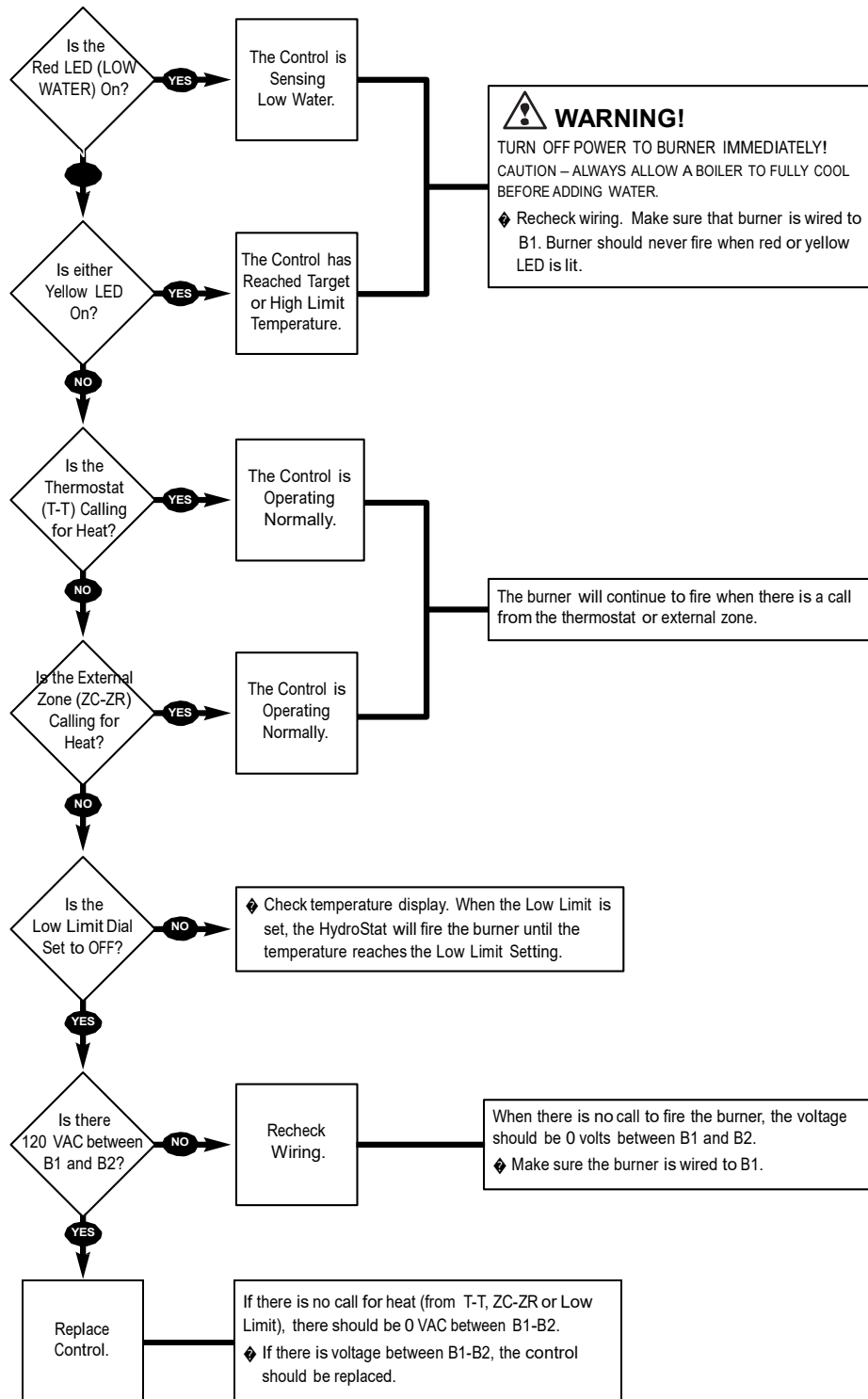

## 12 Service Parts

All AP-U™ Series Service Parts may be obtained through your local New Yorker Wholesale distributor. Should you require assistance in locating a New Yorker distributor in your area, or have questions regarding the availability of New Yorker products or service parts, please contact: New Yorker Boiler Co., LLC., P.O. Box 3005, Lancaster, PA 17604-3005, ATTN: Customer Service Department.

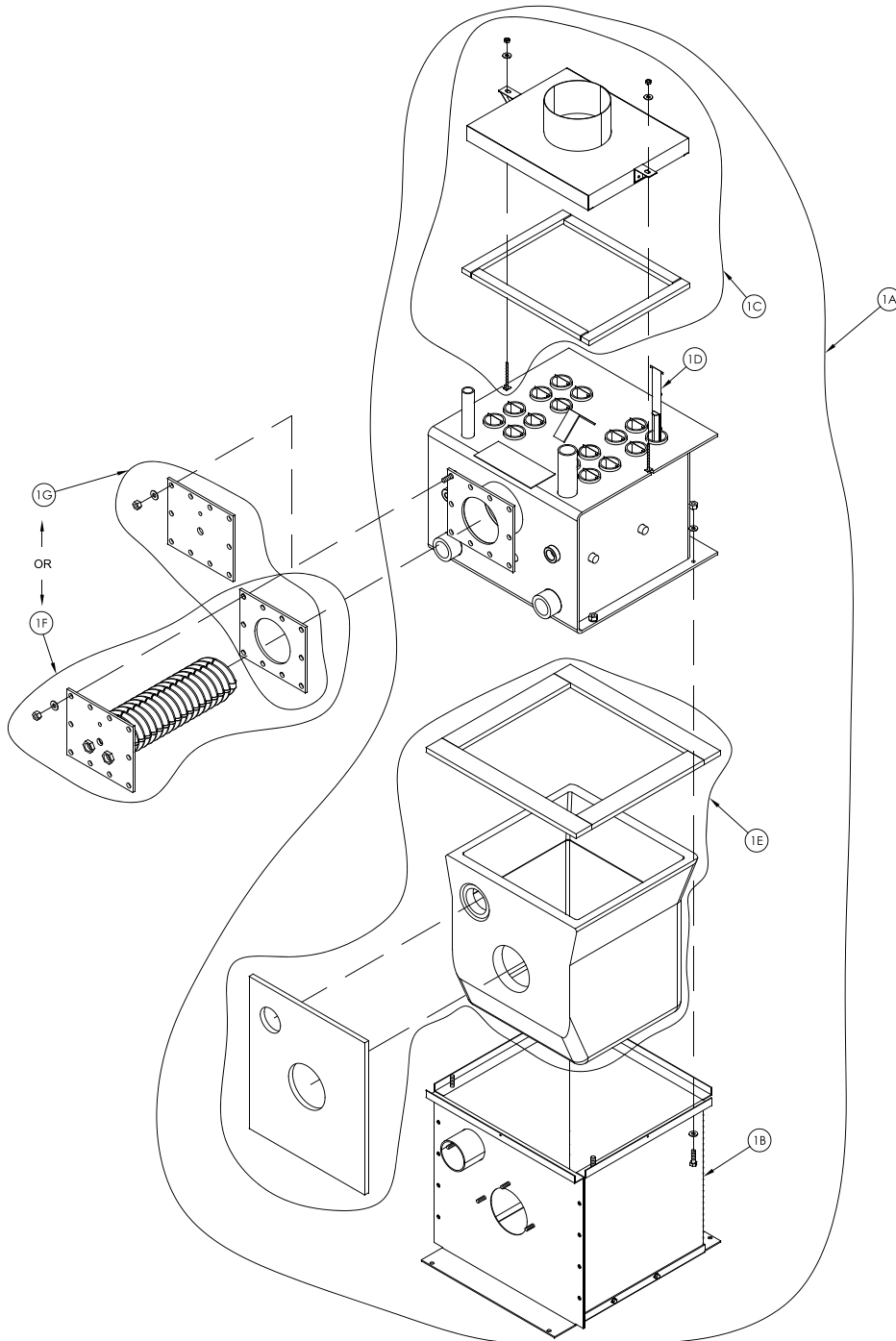

Figure 12-1: Service Parts Bare Boiler Assembly

## 12 Service Parts *(continued)*

### AP-U Bare Boiler

Item No.	Description	Part Number	AP-110U-N(T)	AP-154U-N(T)
1A	BBA Assembly Includes: Shell Assembly, Base, and Canopy	S-101	110840-01	1
		S-301	110841-01	1
1B	Base Assembly	110842-01	1	1
1C	Canopy Includes: Cerafelt Strips and Hardware	110843-01	1	1
1D	Turbulator Kit	S-101	110844-01	16
			111600-01	1
		S-301	110845-01	16
			111601-01	1
1E	Combustion Chamber Insulation Kit	62071001	1	1
1F	S5A Tankless Coil Includes: Gasket and Hardware	103074-01	1	1
1G	S5A Heater Cover Plate Includes: Gasket and Hardware	6037203	1	1

## 12 Service Parts *(continued)*

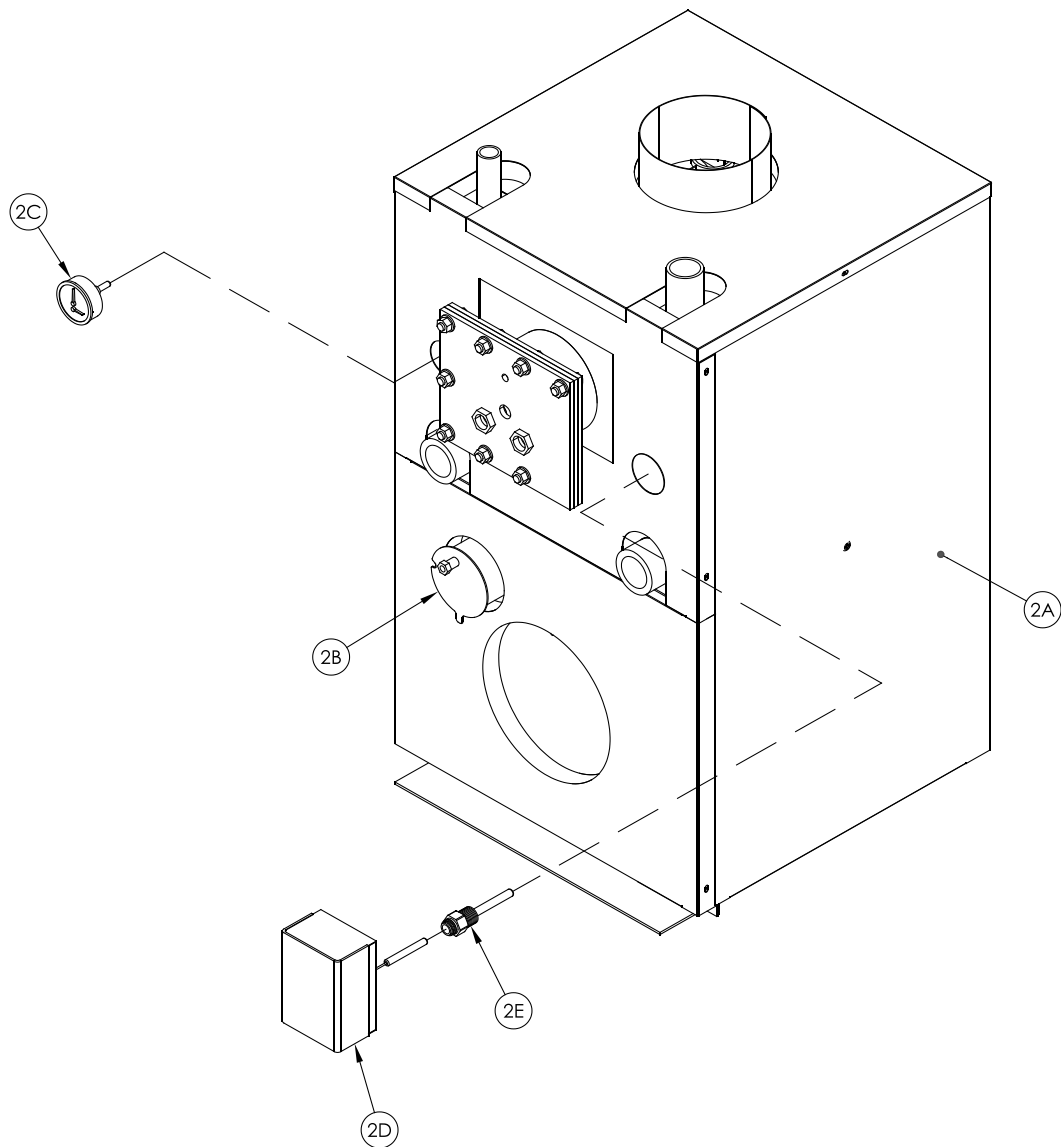

**Figure 12-2: Service Parts Jacket and Trim**

**NOTE:** When ordering parts always give the serial number and model number shown on the boiler. Also provide the name of the part(s) shown below:

## 12 Service Parts *(continued)*

### AP-U Trim

Item No.	Description		Part Number	AP-110U-N(T)	AP-154U-N(T)
2A	Complete Jacket Carton Includes: Labels and Hardware	S-101	110846-01	1	
		S-301	110847-01		1
2B	Observation Port Cover		110848-01	1	1
2C	Temperature/ Pressure Gauge		105894-01	1	1
2D	Limit, Hydrolevel HydroStat 3250 Plus	Non Heater	110849-01	1	1
		Heater	110850-01	1	1
2E	Electro-Well, 3/4 in. NPT x 4 in.		110556-01	1	1
Not Shown	Taco 007e		Obtain Locally	1	1
	Relief Valve, Conbraco	#10-407-05 30 PSI		1	1
	6 in. Draft Regulator			1	1
	Drain Valve, 3/4 in. NPT			1	1

### AP-U Oil Burners

Item No.	Description		Part Number	AP-110U-N(T)	AP-154U-N(T)
Not Shown	Beckett	Natural Draft	80271001	1	
			80271003		1
	Primary Control	Becket GeniSys	Obtain Locally	1	1

New Yorker Boiler Company, LLC  
P.O. Box 3005  
Lancaster, Pennsylvania 17604-3005  
Attn: Customer Service Department  
[www.newyorkerboiler.com](http://www.newyorkerboiler.com)