



ROCKFORD SEPARATORS

5159 28th Ave ROCKFORD, IL 61109
 (815) 229-5077 - FAX (815) 229-5108
 www.rkfdseparators.com - rssem@rkfdseparators.com

MODEL NO. GF-3475-R

GREASE SEPARATOR

DRAWN BY R.P.P.

QUOTE#:

DATE: 03/31/22

JOB NAME:

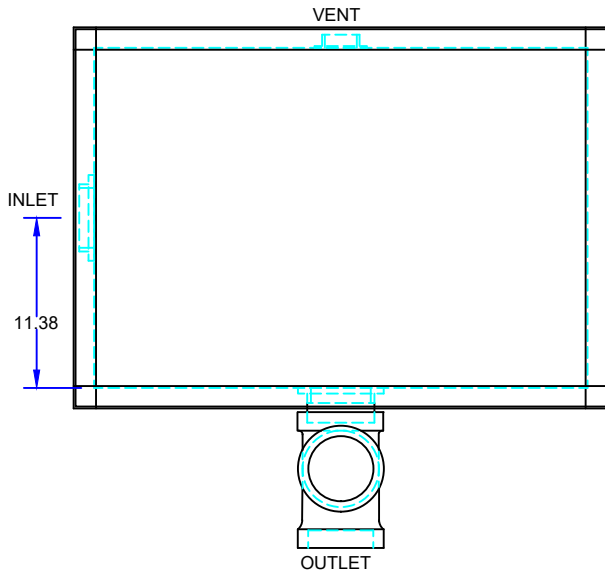

OPTIONAL FEATURES (ADDITIONAL COST)

- ANCHOR FLANGE
- CLAMP RING
- RECESSED LIFT HANDLES IN COVERS
- EPOXY COATING
- ANODES
- REINFORCED COVER
- STAINLESS STEEL CONSTRUCTION
- SEDIMENT BASKET
- FILTER MEDIA
- INTEGRAL EXTENSION _____ INCHES
- ALTERNATE VENT TAPPING SIZE _____ INCHES
- ALTERNATE INLET & OUTLET SIZE _____ INCHES
- CAST IRON OUTLET FITTINGS
- PVC OUTLET FITTINGS

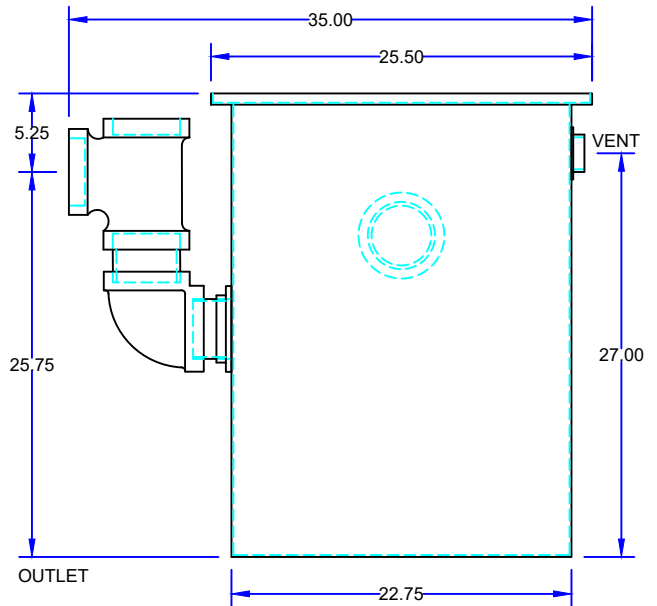
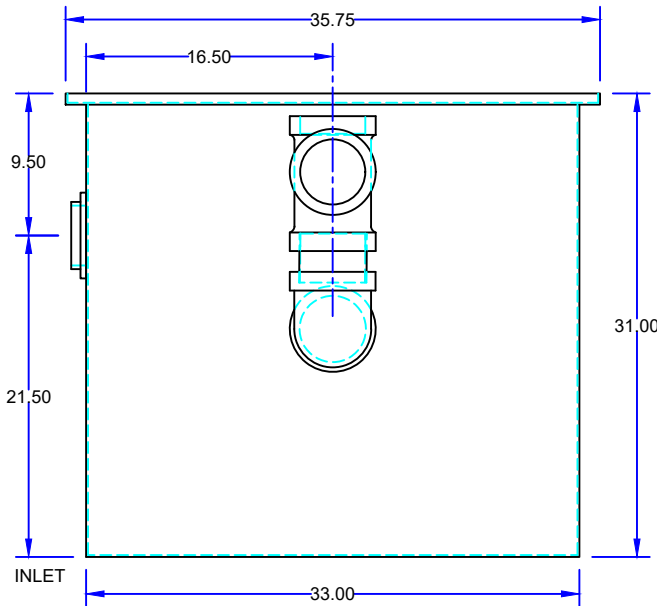

SPECIFICATIONS

Rockford Model GF-3475-R all welded 10 Ga. steel separator, 80 gallon static capacity, 75 g.p.m. intermittent flow, 4.00" tapped inlet/outlet with 2.00" tapped internal vent connection, 403 lbs greasy sludge capacity, visible double-wall outside trap seal, easily removable separator screen and filter screen, removable 3/8" nonskid diamond tread plate cover for flush with floor installation suitable for pedestrian traffic secured with stainless flat head screws, heavy duty leak-proof gasket, OPEX Shop Coat coating inside and bituminous coating outside.

Optional features (Additional cost) listed above

Approved By

Company

Date