

SUBMITTAL DATA SHEET

NI_G_IN_00154.docx
Rev. -1 of 16/01/2024



NIRON CLIMA VALVES PP-RCT TRUE UNION BALL VALVE SPIGOT ENDS SDR 11

ITEM: 27NRSPRCTS_
SIZE RANGE: 3/4" (25 mm) ÷ 4" (125 mm)
SDR: 11
FUSION RANGE: For Butt Fusion – SDR11
For Electrofusion – SDR11 and up
MATERIAL: PP-RCT (Borealis RA 7050 beta crystalline random copolymer PP)
COLOR: Steel Grey

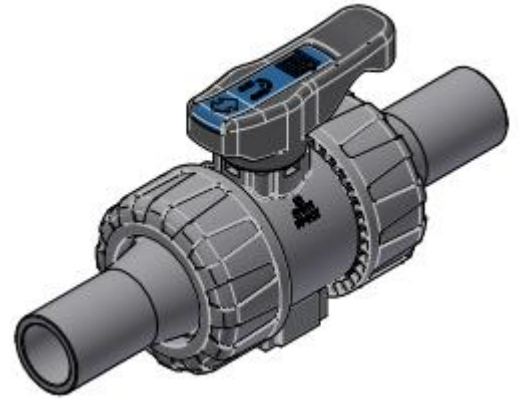

INSTALLATION INSTRUCTIONS:

Butt fusion - Butt fitting in accordance with DVS 2207, ASTM D2657 and NUPI Niron Installation Manual
Electrofusion - Electrofusion in accordance with ASTM D2657 and NUPI Niron Installation Manual

HYGIENIC LAW AND SPECIFICATIONS:

NSF 61 (Drinking Water System Components – Health Effects).

D.M. 174: (Italy: Ministry of Health. Regulations concerning materials and objects that can be used in fixed systems for collection, treatment, adduction and distribution of water intended for human consumption).

STANDARDS:

Coupled with pipes according to EN ISO 15494 (Plastics Piping Systems for Industrial Applications), EN ISO 15874 (Plastics Piping Systems for Hot and Cold Water Installations), ASTM F2389 (Standard Specifications for Pressure-Rated Polypropylene (Pp) Piping Systems).

MAXIMUM OPERATING PRESSURE:

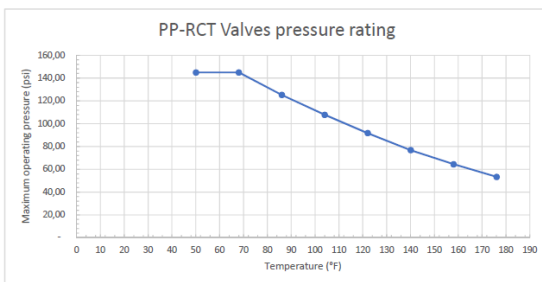

For code or standard question pertaining to NIRON CLIMA Pipe and Fittings, contact Nupi Americas.

PRODUCT INFORMATION AND APPLICATION USE:

Niron Butt Fusion Fittings is designed to be joined by means of heat element butt fusion or electrofusion in accordance with the above listed installation instructions. Fittings are manufactured with extended plain ends on each outlet which a reinforced area in the center of the fitting for strength. The dimensions of the fittings are in accordance with the requirements of ASTM F2389. The fittings are designed to match the wall thickness and pressure ratings of the matching Niron pipe of the same SDR. Fittings are unitary and injection molded and are solid grey in color.

COLD WATER 73.4°F

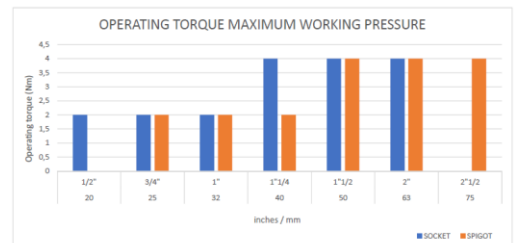

HOT WATER 176°F

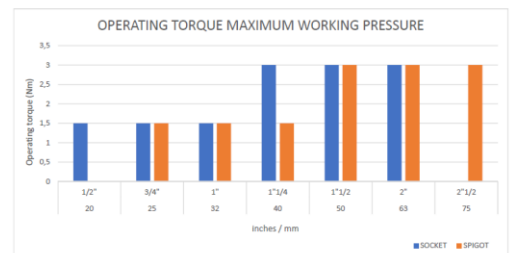

Nupi Americas, Inc.
314 Commerce Parkway
Early Branch, SC 29916
Phone: 813-398-3579
Fax: 813-398-3639
Mail: info@nupiamericas.com
Website: www.nupiamericas.com

SUBMITTAL DATA SHEET

NI_G_IN_00154.docx
Rev. -1 of 16/01/2024

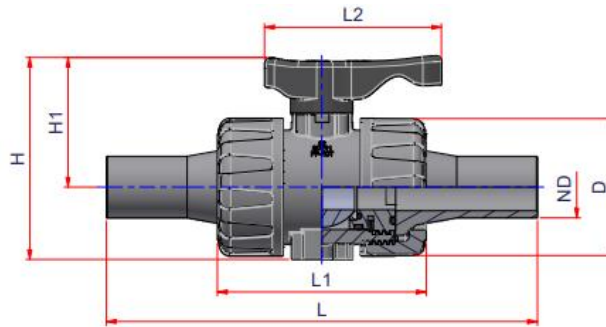

CODE	TYPE	Body Type	Weight lbs/pc	Volume ft ³ /pc	ND	D	L1	L2	L3	L	H1
27NRSPPRCTS25	A	1"	0.74	0.0629	3/4" => 25 mm	2.8	1.65	4.27	3.61	9.22	2.69
27NRSPPRCTS32	A	1"	0.815	0.0614	1" => 32 mm	2.8	1.73	4.27	3.61	8.98	2.69
27NRSPPRCTS40	A	1"	0.886	0.0726	1 1/4" => 40 mm	2.8	2.47	4.27	3.61	10.63	2.69
27NRSPPRCTS50	A	2"	2972	0.227	1 1/2" => 50 mm	4.78	2.56	6.27	5.25	13.47	4.31
27NRSPPRCTS63	A	2"	3199	0.2569	2" => 63 mm	4.78	2.94	6.27	5.25	13.47	4.31
27NRSPPRCTS75	A	2"	3386	0.2561	2 1/2" => 75 mm	4.78	3.29	6.27	5.25	14.02	4.31

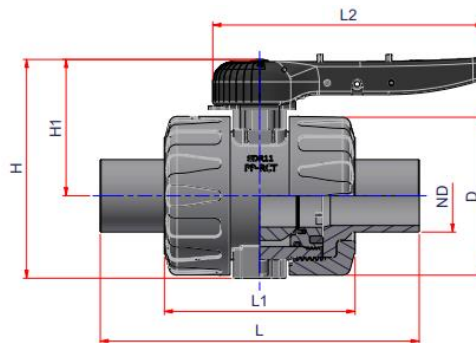

CODE	TYPE	Body Type	Weight lbs/pc	Volume ft ³ /pc	ND	D	L1	L2	L3	L	H1
27NRSPPRCTS90	B	3"	12.039	0.7673	3" => 90 mm	7.76	3.14	9.37	13.29	15.61	6.9
27NRSPPRCTS110	B	3"	12.297	0.7943	3 1/2" => 110 mm	7.76	3.41	9.37	13.29	16.16	6.9
27NRSPPRCTS125	B	3"	12.78	0.8543	4" => 125 mm	7.76	3.81	9.37	13.35	17.24	6.93



Nupi Americas, Inc.
314 Commerce Parkway
Early Branch, SC 29916
Phone: 813-398-3579
Fax: 813-398-3639
Mail: info@nupiamericas.com
Website: www.nupiamericas.com

SUBMITTAL DATA SHEET

NI_G_IN_00154.docx
Rev. -1 of 16/01/2024



ACCESSORIES:

	CODE	DESCRIPTION
	27NAPP_	PP-RCT WELDING COLLAR SOCKET FUSION END
	27NAPVC_	WELDING COLLAR PVC SOLVENT CEMENT JOINT
	27NAPPS_	PP-RCT WELDING COLLAR SPIGOT ENDS
	27NAPES_	PE WELDING COLLAR SPIGOT ENDS
	27NARS_GS_	INSTABRANCH™ WELDING SOCKET ADAPTER FOR PP-RCT VALVE
	27NARS_K_	COMPRESSION FITTING ADAPTER FOR PP-RCT VALVE
	27NRSEXL_	STEM EXTENSION FOR BALL VALVE LONG VERSION
	27NRSEXS_	STEM EXTENSION FOR BALL VALVE SHORT VERSION
	27NFBAF_	FIXING BRACKET FOR ACTUATORS
	27NAPVCF_NPT	WELDING COLLAR PVC SOLVENT CEMENT JOINT WITH NPT THREAD
	00CHGH_	TIGHTENING WRENCH FOR BALL VALVES



Nupi Americas, Inc.
314 Commerce Parkway
Early Branch, SC 29916
Phone: 813-398-3579
Fax: 813-398-3639
Mail: info@nupiamericas.com
Website: www.nupiamericas.com

SUBMITTAL DATA SHEET

NI_G_IN_00154.docx
Rev. -1 of 16/01/2024



VALVE COMPONENTS:

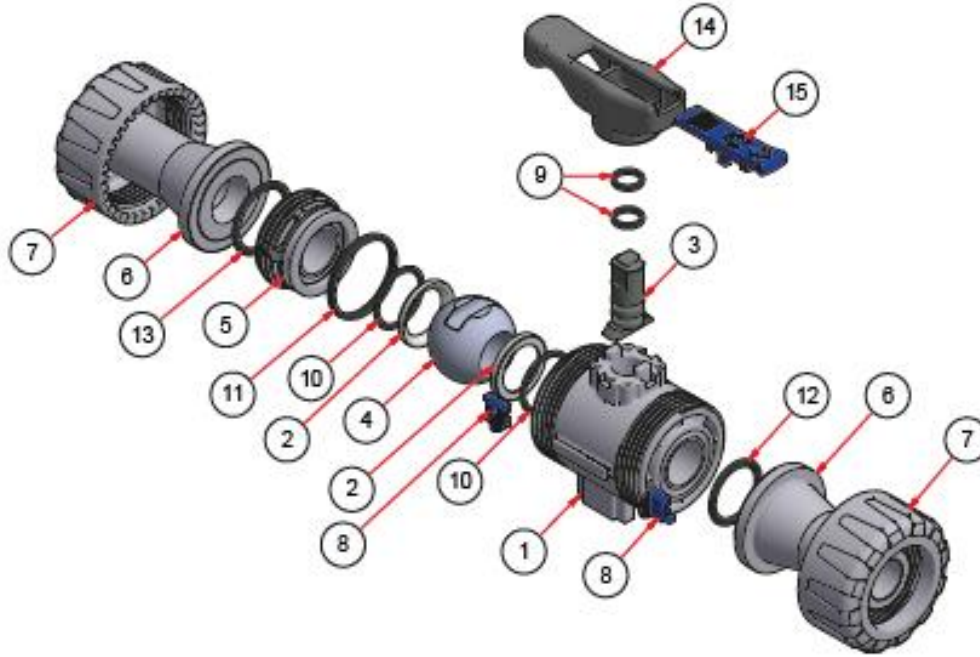

	DESCRIPTION	Q.TY
1	Body valve	1
2	Teflon ball seat	1
3	Command rod	2
4	Ball	1
5	Internal screw nut	1
6	Stub end long spigot	1
7	Outer ring	1
8	Block cursor	1
9	Rod seal o-ring	2
10	Teflon seal o-ring	2
11	Radial seal o-ring	1
12	Socket seal o-ring	1
13	O-ring seal (side internal screw nut)	1
14	Handle	1
15	Handle insert	1



Nupi Americas, Inc.
314 Commerce Parkway
Early Branch, SC 29916
Phone: 813-398-3579
Fax: 813-398-3639
Mail: info@nupiamericas.com
Website: www.nupiamericas.com

SUBMITTAL DATA SHEET

NI_G_IN_00154.docx
Rev. -1 of 16/01/2024

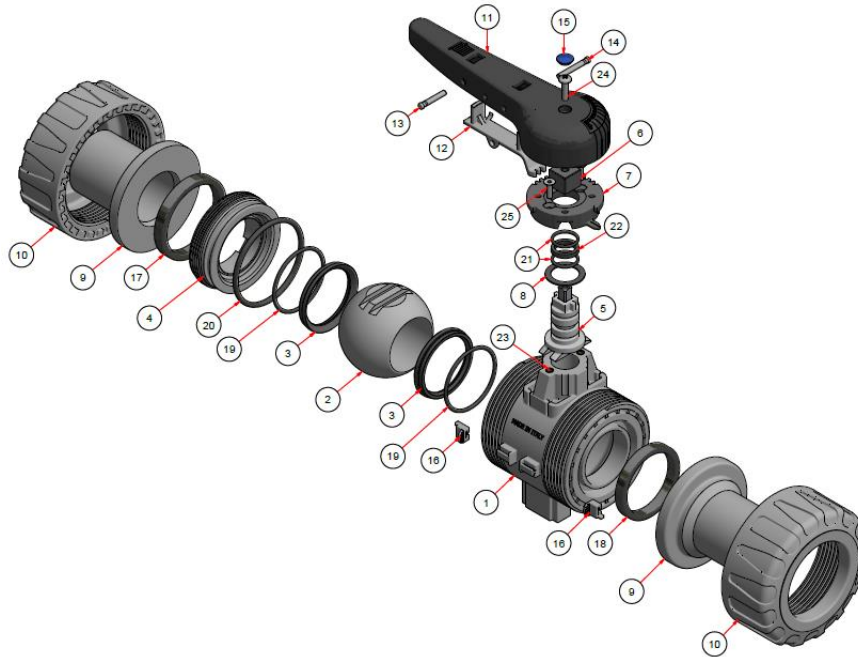

	DESCRIPTION	Q.TY
1	Body valve	1
2	Ball	1
3	Teflon ball seat	2
4	Internal screw nut	1
5	Command rod	1
6	Handle insert	1
7	Handle lock plate	1
8	Teflon rod seal	1
9	Stub end long spigot	2
10	Outer ring	2
11	Handle	1
12	Handle lock insert	1
13	Handle insert pin	1
14	Handle insert pin	1
15	Handle cap	1
16	Block cursor	2
17	O-ring seal (side internal screw nut)	1
18	Socket seal o-ring	1
19	Teflon seal o-ring	2
20	Radial seal o-ring	1
21	Rod seal o-ring	2
22	Rod seal	1
23	Body valve threaded insert	2
24	Handle screw	1
25	Handle lock plate screw	2





Nupi Americas, Inc.
314 Commerce Parkway
Early Branch, SC 29916
Phone: 813-398-3579
Fax: 813-398-3639
Mail: info@nupiamericas.com
Website: www.nupiamericas.com

SUBMITTAL DATA SHEET

NI_G_IN_00154.docx
Rev. -1 of 16/01/2024



SPARE PARTS:

	CODE	DESCRIPTION
	OORSPPRCKIT_	REPLACEMENT EPDM GASKET KIT
	OORSPPRCKIT_V	REPLACEMENT VITON GASKET KIT

MANUFACTURER' S WARRANTY:

Thirty (30) Years from the date of sale upon successful completion of pressure test of the piping system (refer to published warranty for complete details).

NOTE:

* More information can be found on NIRON TECHNICAL CATALOGUE

** Weld Depth (WD) is the insertion depth of the pipe for socket fusing

*** For Niron pipe and fittings to meet E-84 and/or CAN/ULC S102.2 for installation in a plenum application, it must be covered with a minimum of 1" or greater E-84 fiberglass insulation

**** Technical Data may undergo dimensional changes, check revision at the top

***** Available in blue or red version



Nupi Americas, Inc.
314 Commerce Parkway
Early Branch, SC 29916
Phone: 813-398-3579
Fax: 813-398-3639
Mail: info@nupiamericas.com
Website: www.nupiamericas.com