

Builder SERIES

by InSinkErator®



BLD30

Submittal Sheet

This model offers the following features and benefits:

- MAGNADRIVE™ 1/3 HP permanent magnet motor
- 1-Stage Grind: Reliable grind for everyday food scraps
- 3D Grind Zone: Engineered to grind and rinse the disposal
- Lift & Latch® technology for simplified installation
- Power cord attached for hassle-free outlet connections
- Safe for use with properly maintained septic tanks

Sample Specification

Food Waste Disposer(s) shall be InSinkErator BLD30, continuous feed, with 1/3 HP motor, galvanized steel grind components with two stainless steel lugs.

Warranty

1-year *We Come to You™* In-Home limited warranty

* The complete InSinkErator warranty is included in the Care & Use Booklet packed with each unit.

Dimensions

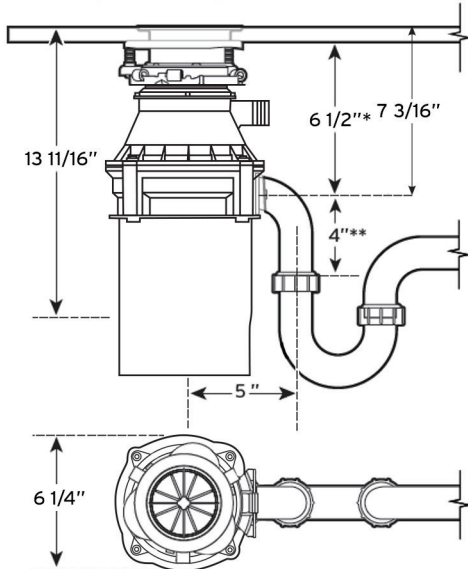

Specifications

Type of Feed	Continuous
On/Off Control	Wall Switch
Motor	Single Phase
HP	1/3
Volts	120
HZ	60
Amp. (Avg. Load)	2.5A
Time Rating	Intermittent
Lubrication	Permanently Lubricated Upper & Lower Bearings

Shipping Weight (Approx.)	14 lb.
Overall Height	15.6"
Motor Protection	Automatic Reset
Average Water Usage	Approx. 1 Gallon per Person Per Day
Average Electrical Usage	3-4 KWh per Year
Drain Connection	1-1/2" cushioned slip joint
Dishwasher Drain Connection	Yes

Job Specifications



Food waste is roughly 80% water. By using your disposal regularly, you can help divert food waste from landfills and reduce greenhouse gas emissions. Make sustainability a family affair by using your disposal. After all, the smallest changes can make the biggest impact.

1-800-558-5700
www.insinkerator.com