

resideo



Braukmann EA122A1002 Automatic Air Vent

INSTALLATION INSTRUCTIONS

The Resideo Braukmann EA122A1002 Automatic Air Vent purges air from hydronic heating systems and equipment in hot or cold closed water systems up to 230° F (110° C). The EA122 includes a built-in shutoff valve for servicing without system shutdown; safety drain connection, and vent cap with leakage guard.

Removable float/valve assembly for easy servicing. Body: Engineered thermoplastic with brass base, internal parts made of corrosion and chemical-resistant materials for use with water systems containing glycol, mineral oils, or petroleum-based oils. Maintains quiet and efficient operation.

SPECIFICATIONS

Materials of Construction:

Body, Float, Valve Lever and Cover:
Engineered thermoplastics

Seal Disc and Rings: Synthetic rubbers

Operating Ratings:

Maximum Pressure: 90 psi

Maximum Temperature: 230° F (110° C)

Connections: 1/8 in. NPT male pipe thread

Dimensions: See Fig. 1

Capacities: See Fig. 2

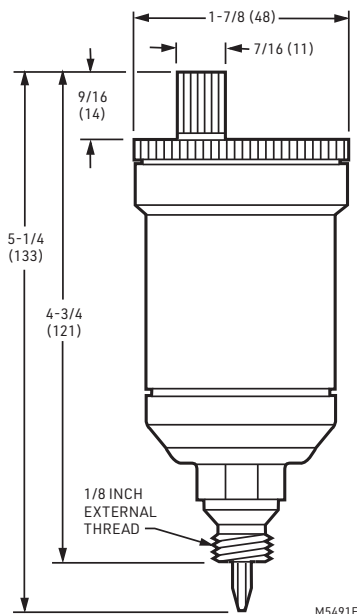

Fig. 1. EA122A dimensions in in. (mm).



33-00562-03

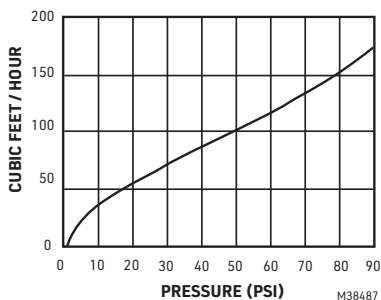

Fig. 2. EA122A1002 flow capacities, with leakage guard cap.

NOTE: Capacity indicated is for device with leakage guard cap installed and operational. Additional capacity may be obtained by removing the leakage guard cap and installing a connection between the vent discharge and drain using Q122A1001 Safe Waste Container.

INSTALLATION

When Installing This Product...

1. Read these instructions carefully. Failure to follow them could damage the product or cause a hazardous condition.
2. Check the ratings given in the instructions and on the product to make sure the product is suitable for your application.
3. Installer must be a trained, experienced service technician.
4. After installation is complete, check out product operation as provided in these instructions.



CAUTION

Do not use tools to adjust the EA122A or damage to the vent may result. Use hands only to adjust vent. A wrench may be used only on hex during installation.

Location

Install the EA122A on the positive side of the circulator pump at the point where air will accumulate. This is usually the high point of the supply or the return main in the system as shown in Fig. 3.

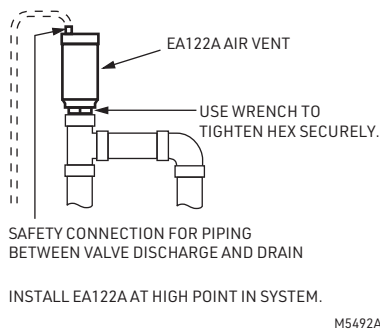

Fig. 3. Install the EA122A at high point in system.

INSTALLATION

1. Fit EA122A vent in piping at a location as specified in the Location section.
2. Turn EA122A until vent fits tightly on piping. Use a wrench to securely tighten hex.
3. If safety drain connection is desired, install a pipe between vent discharge and drain using Q122A1001 Safe Waste Connector.
4. Make sure that the red vent cap is securely tight, and that the valve is in the closed position by turning vent body clockwise. See Fig. 4. Use hands only to avoid damaging the vent.
5. With the valve in the closed position, flush the system as required to remove dirt, debris, and contaminants.
6. Fill the system with the appropriate solution.
7. Operate the EA122A by turning the air vent body counterclockwise to the open position. Use hands only. See Fig. 4.

- Make sure the red vent cap is tightened all the way to the stop position for proper operation. Use hands only to tighten.

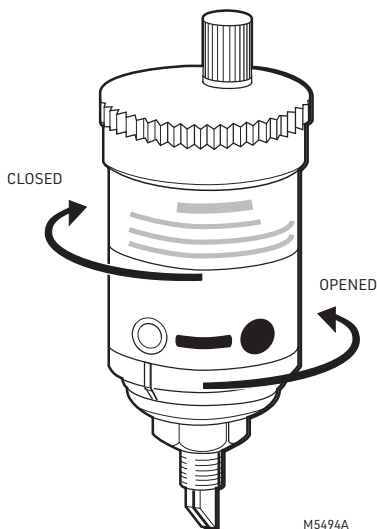

Fig. 4. Turn vent body counterclockwise to open or clockwise to close.

OPERATION

The EA122A operates as follows:

Opening the air vent (turning valve body counterclockwise) exposes the EA122A to the system. Water and air may enter the vent chamber. The float will fall through any air in the chamber. This opens the vent seat.

The red vent cap allows air to pass through the open vent. As the air is released through the vent cap, water replaces the air in the vent chamber and the float rises. This closes the vent seat. When additional air enters the vent chamber, the operation repeats.

If the vent seat remains open, water will rise through the vent and cause the swelling disks inside the red cap to close

off the vent. Closing the air vent (turning valve body clockwise) isolates the EA122A from the system, allowing service.



CAUTION

The EA122A may be hot due to system temperature extremes. Use caution when adjusting vent to prevent burning hands.

The EA122A may become accumulated with dirt in the seat area of the float assembly, which may cause the vent to malfunction. Periodic cleaning is recommended to prevent the vent from malfunctioning.

NOTE: The EA122A may be serviced without depressurizing or draining the system.

To clean the seat area, proceed as follows:

- Turn the vent body clockwise to the closed position, isolating the vent from the system. See Fig. 4.
- Remove the float assembly by unscrewing the top of the body and lifting the black cover assembly up. See Fig. 5.

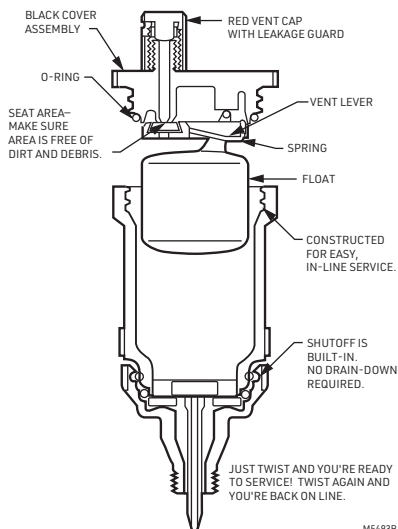

Fig. 5. EA122A construction.



CAUTION

Do not bend spring on float assembly or damage to the vent may result.

3. Carefully clean the seat area of any dirt or debris.
4. Carefully clean any dirt or debris from inside the vent chamber.
5. Replace the float assembly, making sure that the O-ring is seated properly. See Fig. 5.

6. Replace black cover assembly on air vent body using hands only until handtight.
7. Operate the EA122A by turning the air vent body counterclockwise to the open position. Use hands only. See Fig. 4.
8. Make sure the red vent cap is tightened all the way to the stop position for proper operation. Use hands only to tighten.

TROUBLESHOOTING



CAUTION

The EA122A may be hot due to system temperature extremes. Use caution when adjusting vent to prevent burning hands.

Problem	Action
The EA122A is not venting air or there is too much air in the system.	<ol style="list-style-type: none"> 1. Check the red vent cap; make sure the vent passage is open (disks are not swelled). 2. Check that the valve is in the open position. 3. Make sure that the float is attached to the vent lever as shown in Fig. 5.
Water is leaking from the EA122A.	<ol style="list-style-type: none"> 1. Make sure the red vent cap is tightened all the way to the stop position. 2. Adjust the valve to the closed position by turning the vent body clockwise. 3. Clean the vent as described in the Service section. 4. If internal parts appear damaged or deteriorated, replace cover assembly (Part No. P122B1002).



resideo

Resideo Technologies, Inc.

1985 Douglas Drive North, Golden Valley, MN 55422

1-800-468-1502

www.resideo.com

33-00562-03 M.S. Rev. 02-21 | Printed in United States