

Immersion Wells and Compression Fittings FOR TEMPERATURE CONTROLLERS

PRODUCT DATA

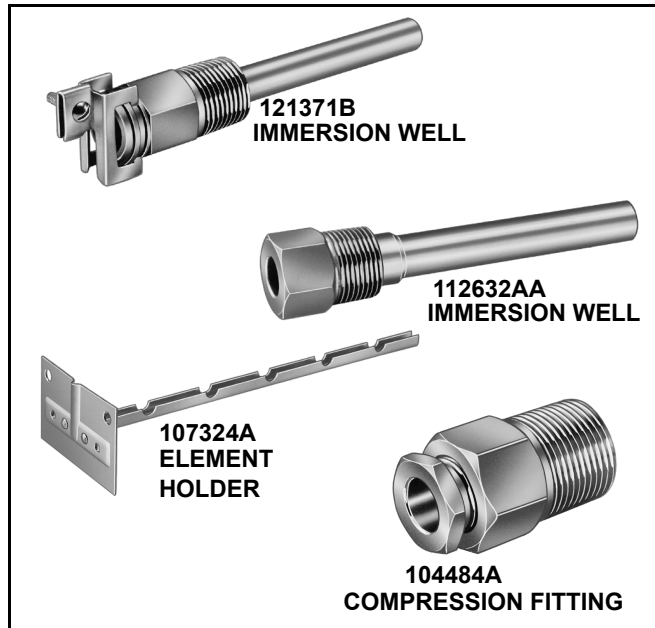

FEATURES

- Immersion wells and compression fittings are available to fit a 1/2-14 or 3/4-14 NPT tapping with a range of insulation depths.
- Immersion wells and compression fittings are available in a variety of lengths and diameters.
- Immersion wells and compression fittings are available in a variety of materials, to suit the application. Materials include: brass, copper, stainless steel, mild steel or Monel.
- Element holders support the capillary and bulb or an averaging element in duct applications.
- Bulb shields protect the sensing bulb from sun and weather with the bulb installed outdoors.
- Accessories, including mounting clips, heat-conductive compound, waste nuts, a pipe strap and a well adapter, are available for mounting sensing bulbs in various applications.
- Immersion wells allow heat transfer while protecting the sensing bulb from contact with the controlled medium.
- Immersion wells permit removal of the sensing bulb for testing or replacement without draining the system.
- Compression fittings seal the boiler and allow bulb insertion directly into the controlled medium.

APPLICATION

Immersion wells, compression fittings and element holders are used with Aquastat® Temperature Controllers to hold the temperature sensing bulb in the controlled medium. Immersion wells and compression fittings also prevent leakage of the controlled medium.

Contents

Application	1
Features	1
Specifications	2
Ordering Information	2
General Information	7
Installation	8
Checkout	13
Cross Reference	13



SPECIFICATIONS

Models:

Immersion Wells: Allow heat transfer while protecting sensing bulb from controlled medium and seal off tapping to permit bulb removal without draining the boiler. Available in copper, stainless steel, mild steel and Monel. See Table 1 for copper. See Table 2 for stainless steel, mild steel and Monel.

Compression Fittings: Allow bulb insertion directly into the controlled medium with boiler draining. Can also be used to provide positive seal in duct applications. Available in brass and stainless steel. See Table 3.

Element Holders: Support bulb and capillary or averaging element in a duct. See Table 4.

Dimensions:

See Tables 1, 2, 3 and 4, and Fig. 1 and 2.

Temperature Ratings:

IMPORTANT

Do not exceed the maximum temperature rating of the controller element.

Wells:

Copper: 300°F (149°C) maximum.

Other Materials: Maximum temperature rating limits of the controller sensing bulb and capillary.

Capillary Compression Fittings: 250°F (121°C) maximum.

Element Holders:

311266D Bulb Holder: -40°F to +100°F (-40°C to +38°C).

Other Element Holders: Maximum temperature rating limits of the controller sensing bulb and capillary.

Maximum Pressure Ratings:

Copper Wells: 255 psi (1758 kPa) at 300°F (149°C).

Other Wells: 1500 psi (10,342 kPa) at 700°F (371°C).

Capillary Compression Fittings:

Water: 50 psi (345 kPa)

Air: 15 psi (103 kPa).

Accessories:

See Tables 5 and 6.

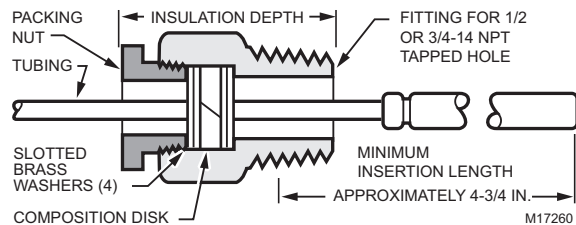

Fig. 1. Capillary compression fitting dimensions and components.

ORDERING INFORMATION

When purchasing replacement and modernization products from your TRADELINE® wholesaler or distributor, refer to the TRADELINE® Catalog or price sheets for complete ordering number.

If you have additional questions, need further information, or would like to comment on our products or services, please write or phone:

1. Your local Home and Building Control Sales Office (check white pages of your phone directory).
2. Home and Building Control Customer Relations
Honeywell, 1885 Douglas Drive North
Minneapolis, Minnesota 55422-4386

In Canada—Honeywell Limited/Honeywell Limitée, 35 Dynamic Drive, Scarborough, Ontario M1V 4Z9.

International Sales and Service Offices in all principal cities of the world. Manufacturing in Australia, Canada, Finland, France, Germany, Japan, Mexico, Netherlands, Spain, Taiwan, United Kingdom, U.S.A.

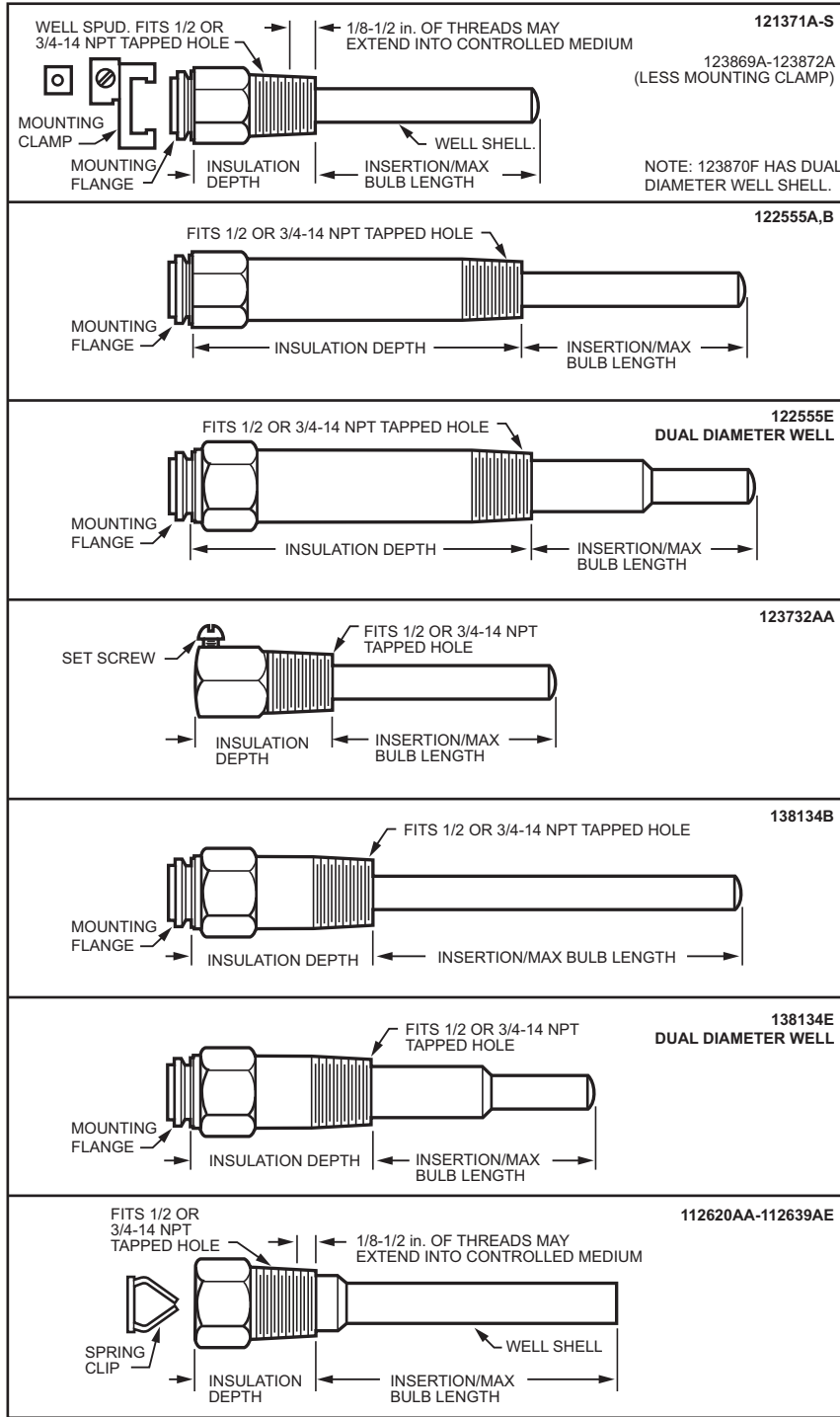

M17259A

Fig. 2. Immersion well dimensions and components.

Table 1. Copper Immersion Wells.

Spud in in. x 14 NPT	Shell ID/ Bulb Diameter	Insertion/ Max Bulb Length	Insulation Depth	Capillary Diameter	Includes	Part Number	
1/2	3/8	3	1-1/2	5/64	121371 Mounting Clamp	121371A	
				—	—	123869A	
		3	1-1/2	5/64	121371 Mounting Clamp	121371L	
				—	121371 Mounting Clamp	121371P	
				1/8	112721 Spring Clip	112620AA	
	1/2	4	1-1/2	1/8	—	Plastic sleeve on well tube	123869B
					—	112721 Spring Clip	112622AA
		4-1/4	4-1/2	1/8	—	112721 Spring Clip	112626AA
					—	—	—
					—	—	—
3/4	3/8	3	1-1/2	5/64	121371 Mounting Clamp	121371B	
				—	—	123870A	
			3	1-1/2	5/64	121371 Mounting Clamp	121371M
					—	121371 Mounting Clamp, plastic sleeve	123171N
					—	—	123871A
		4-1/2	1-1/2	5/64	—	Plastic sleeve on well tube	123871B
					—	—	122555D
					—	Plastic sleeve on well tube	122555A
					—	—	—
					—	—	—
	3-1/2	1-1/2	5/64	—	121371 Mounting Clamp	121371Q	
				—	—	138134B	
				—	Plastic sleeve on well tube	122555B	
				—	—	122555C	
				—	—	—	
3/8 + 5/8	3	2-1/4	1-1/2	5/64	Plastic sleeve on well tube	138134E	
					—	—	—
	4-1/4	4-1/2	1-1/2	5/64	—	122555E	
					—	—	—
					—	—	—
1/2	4-1/4	1-1/2	1/8	112721 Spring Clip	—	112630AA	
					—	112634AA	
					—	112630AB	

Table 2. Stainless Steel, Mild Steel, and Monel Immersion Wells.

Spud in in. x 14 NPT	Shell ID/ Bulb Diameter	Insertion/ Max Bulb Length	Insulation Depth	Capillary Diameter	Material	Includes	Part Number
1/2	3/8	3	1-1/2	5/64	Stainless steel	121371 Mounting Clamp	121371E
					Mild steel	112721 Spring Clip	112623AA
	1/2	4-1/4	1	1/8	Stainless steel	112721 Spring Clip	112624AA
					Stainless steel	112721 Spring Clip	112628AA
					Stainless steel	112721 Spring Clip	112632AA

Table 3. Capillary Compression Fittings.

Material	Spud	Maximum Bulb Diameter	Insulation Depth	Capillary Diameter	Part Number
Brass	1/2-14 NPT	1/2 in.	1-5/16 in.	5/64 in.	104484A
				1/8 in.	7617M
			1-1/2 in.	5/64 in.	104484C
			2 in.	5/64 in.	7617ABY
	3/4-14 NPT	11/16 in.	1-5/8 in.	5/64 in.	104484B
			1-1/2 in.	1/8 in.	7617P

Table 4. Element Holders for Duct-Mount Applications .

Application	Length	Plate Size	Description	Part Number
Bulb holders	8-5/8 in.	2-3/4 in. x 1-3/4 in.	Supports capillary and bulb in duct; mounting screws not included.	 M17275A 107324A
		2-3/4 in x 3 in.		 M17276A 131524A
	14 in.	3-1/4 in x 3-1/4 in.	Holds 1 or 2 elements in 0°F to 100°F air; grommet holds one 5/64 in. and one 1/8 in. diameter capillary; helps reduce airflow through opening in duct.	 M17277A 311266D
Averaging element holders	—	—	Mounting clip; use with grommet; mounting screws not included; one required per clip.	 M17271 314439
			Use with 1/2 in. EMT thinwall conduit where duct access is limited. Kit includes 4 in. (101 mm) cover plate, 1/2 in. EMT compression fitting, 3/16 in. (5 mm) rubber grommet, clamp assembly, wire ties and mounting screws.	 M17279 7640HX

Table 5. Immersion Well Accessories .



Description	Application	Size in in. (except where noted)	Part Number
Mounting clamp	Holds capillary in place on 123869A-123872A; 122554A,B; 12255A,B,D,E; and 138134B-F Immersion Wells.	1/2 or 3/4 in. well spud; 5/64 capillary	 <p>M17274 121371AA</p>
Spring clip			 <p>M17288 32002656-001</p>
	Holds capillary in place on 1122620AA-112639AB Immersion Wells.	1/2 in well spud; 5/64 capillary	104488
		1/2 in. well spud; 1/8 capillary.	112721
	3/4 in. well spud; 1/8 capillary.	112720	 <p>M17280</p>
Heat-conductive compound	Improves heat conduction in well applications where bulb does not fit tightly.	4 oz. (118 ml)	 <p>M17281 107408</p>
		Single application tube (1/2 oz)	 <p>M17282 120650</p>
Well Adapter	Adapts well with setscrew on spud; for use with direct insertion bulb or 121371AA Mounting Clamp.		 <p>M17283 124904</p>

Table 6. Accessories for Duct-Mount Applications

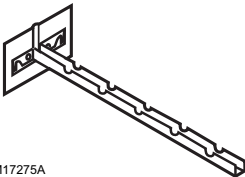
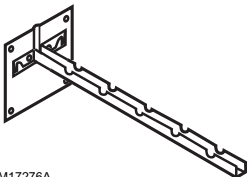
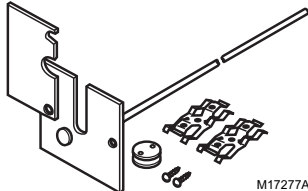
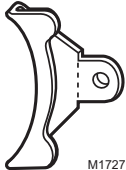
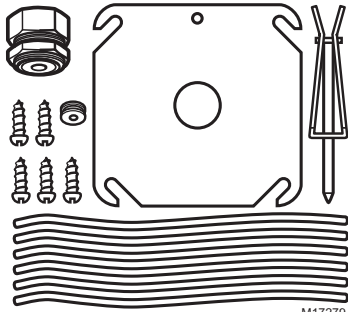
Description	Application	Size	Part Number
Bulb shield assembly	Shields bulb from weather; less mounting screws and split plug.	6 in. (152 mm) long; holds 3/8 in. and 1/2 bulbs.	 <p style="text-align: right; margin-right: 10px;">M17284</p> <p style="text-align: center;">107323A</p>
	Shields bulb from weather; includes mounting screws and 33578 Split Plug.	7 in. (118 mm) long, clip holds 3/8 in. bulb.	 <p style="text-align: right; margin-right: 10px;">M17285</p> <p style="text-align: center;">34886A</p>
Pipe Strap	Fastens bulb to outside of pipe.	4-1/2 in. (114 mm) long; used with up to 3/4 in. OD pipe.	 <p style="text-align: right; margin-right: 10px;">M17286</p> <p style="text-align: center;">105900</p>

GENERAL INFORMATION

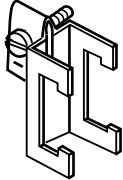
Immersion Wells

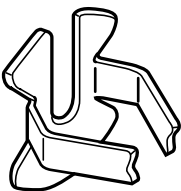
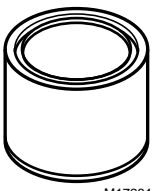
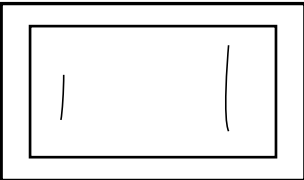
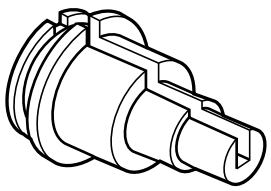
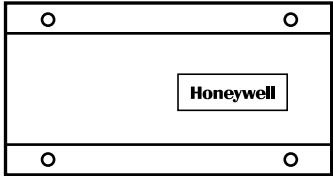
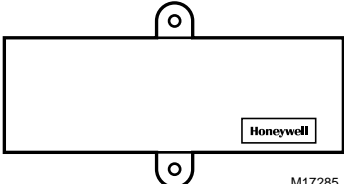
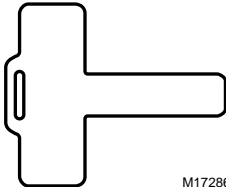
An immersion well consists of a metal tube, called the well shell, closed on one end. A well spud externally threaded to fit standard boiler tapings is welded or brazed on the open end. See Fig. 1. The well is inserted into the tank and the temperature sensing bulb is inserted into the well. The sensing bulb never touches the controlled medium. Because the well conducts heat rapidly, the bulb responds quickly and accurately to temperature changes in the controlled medium.

An immersion well protects the temperature sensing bulb from mechanical damage or damage due to chemical interaction with the controlled medium. Also, a well permits removal of the sensing bulb for testing or control replacement without draining the system. The threaded fitting of the well spud provides a tighter seal than a packing nut applied to the capillary.

Material Selection

The immersion well material must conduct heat readily and resist corrosive and electrolytic action (especially in brine solutions and when the well is a different material than the container). The material must also resist fluid contamination from chemical reaction with the well and withstand high temperatures. Most Honeywell immersion wells are copper

because of its high conductivity. Stainless steel, mild steel and Monel wells are also available for applications requiring higher maximum temperature and pressure ratings or greater corrosion resistance. Some copper wells are available with a plastic sleeve over the tube to reduce electrolytic and corrosive activity.

Well Sizing

Major factors in selecting well size are:

- size of the boiler tapping.
- bulb diameter.
- insulation depth.
- insertion length.

Immersion wells are available to fit standard 1/2-14 NPT and 3/4-14 NPT tapings. Sensing bulbs are 3/8, 1/2 or 11/16 in. in diameter with well shells designed to fit these diameters. The bulb should fit tightly in the shell. If the bulb fits loosely, fill the space between the shell and bulb with heat-conductive compound to ensure maximum heat transfer. Many Honeywell temperature controllers ship with heat-conductive compound; available in 4-oz cans and 1/2-oz single-application tubes. See Table 4.

The nominal length of the spud, including the full length of the threads and the hex, defines the insulation depth. Depending on the characteristics of the tapping, 1/8 to 1/2 in. of the threaded end of the spud can extend into the controlled medium. Consider this additional length when determining how far the well extends into the controlled medium.

The length of the well shell starting at the end of the spud defines the insertion length. This is the *active* part of the well where the fastest heat transfer occurs. The bulb should be the same length as the well shell; however, the well shell can be longer, but not shorter, than the length of the bulb. Longer shells require inserting the bulb until the end touches the well bottom. Shorter shells do not expose the full length of the bulb to the temperature of the controlled medium, inhibiting proper temperature controller operation.

Securing Bulb in Well

REMOTE BULB APPLICATIONS

Securing the capillary at the spud with a spring clip or a mounting clamp holds the sensing bulb securely in place. See Fig. 1. Use the spring-loaded clip on well spuds with no mounting flange. Slip it over the capillary and snap it in place in the end of the spud. The mounting requires sizing to fit both the spud and the capillary diameter. The mounting clamp requires wells with a mounting flange at the spud end. The jaws adjust to fit both 1/2 and 3/4 in. spuds, and it holds a 5/64 in. capillary. Wells are available with and without the matching spring clip or mounting clamp. This mounting hardware is also available separately.

A few wells have a setscrew in the spud. These wells are designed for use on controllers with an armored capillary that has a brass plug at the sensing bulb end; for example, R8182H,J.

DIRECT INSERTION APPLICATIONS

Most Honeywell direct insertion controllers include provision for clamping the controller case on the immersion well spud. This requires a well spud with a mounting flange at the end. If the well spud has a setscrew, but no mounting flange, a 124904 Well Adapter can provide the necessary flange. See Fig. 3. The well adapter is shipped with several Honeywell TRADELINE® direct-insertion controllers.

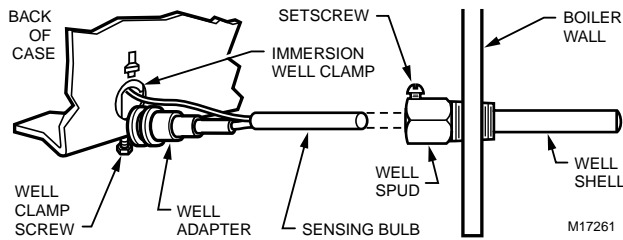

Fig. 3. Mounting direct insertion controller case on well spud.

Capillary Compression Fittings

A capillary compression fitting includes a spud, several aligning washers, a neoprene packing ring and a packing nut. The spud is internally threaded to hold the packing material

and the packing nut and externally threaded to fit standard boiler tappings. The washers and packing ring are sized to fit a particular capillary diameter.

Capillary compression fittings are used to replace an immersion well when the sensing bulb of a remote bulb controller requires direct insertion into the controlled medium. The fitting seals around the capillary. However, compression fittings cannot seal off against as much pressure as immersion wells. Capillary compression fittings can be used in duct applications to minimize air leakage from the duct; a waste nut is recommended to provide a secure mounting.

Material Selection

Capillary compression fittings are available in brass and stainless steel. In hydronic applications, brass fittings with copper sensing bulbs are used and stainless steel is used with all other fittings to minimize electrolytic action.

Sizing

Capillary compression fittings must fit the tapping and the capillary diameter. Because the spud must slip over the bulb during installation, 11/16 in. bulbs require 3/4 in. spuds.

Element Holders

Bulb holders are used to support a remote bulb and capillary in a duct, but are not suitable for hydronic applications. A bulb holder must be selected according to the length needed to support the bulb in the main airstream and the need for plugging the opening in the duct wall.

For best response, string averaging elements evenly back and forth across the duct. The element is held in place with either perforated pipe strap or 314439 Mounting Clips. If access to the duct is limited, use the 7640HX Duct Mounting Kit. Always use a grommet to protect the element from abrasion where it enters the duct.

NOTE: To minimize heat loss through the fitting, use a waste nut and compression fitting.

INSTALLATION

When Installing this Product...

1. Read these instructions carefully. Failure to follow them could damage the product or cause a hazardous condition.
2. Check the ratings given in the instructions and on the product to make sure the product is suitable for your application.
3. Installer must be a trained, experienced service technician.
4. After installation is complete, check out product operation as provided in these instructions.

⚠ WARNING

Severe Scalding Hazard.

Contact with hot liquid can cause severe injury or death.

Drain system before beginning well or compression fitting installation.

⚠ WARNING

Electrical Shock Hazard or Equipment Damage Hazard.
Can cause sever injury, death or short equipment circuitry.
 Disconnect all power supplies before installation.

Most equipment manufacturers provide a tapping for temperature controller sensing element insertion. The tapping should be located to measure average system temperature.

IMPORTANT

Always install the sensing element away from hot or cold water inlets, steam coils, and locations where the well pressure rating will be exceeded.

1. Turn off the power.
2. If the system is filled, drain it to a point below the boiler tapping or sensing element location.
3. If no tapping is provided, prepare one, properly threaded, at the desired location.

Immersion Well Mounting

Instructions for mounting the well in the tapping and using the capillary mounting clamp or spring clip in remote bulb applications follow. Consult the appropriate Aquastat® Controller instructions for mounting the controller on the well in direct insertion applications. Direct insertion applications usually require using wells with a mounting flange on the spud.

1. Coat threads with a moderate amount of pipe dope, leaving two end threads bare. See Fig. 4.

NOTE: Teflon™ tape can also be used.

2. Screw the immersion well into the tapping and tighten securely.

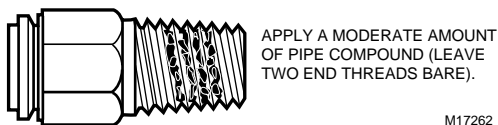

Fig. 4. Proper application of pipe dope.

Insert Sensing Bulb in Well

For good temperature response, the immersion well must fit the sensing element or bulb tightly and rest against the bottom of the well.

NOTE: If necessary, bend the tubing to hold the bulb against the bottom of the well.

IMPORTANT

Any bends made in the piping must be gradual to prevent breaks in the tubing and subsequent loss of fill.

For faster heat transfer, use heat-conductive compound to fill the space between the bulb and the well. A tube of heat-conductive compound ships with Honeywell TRADELINE® Aquastat Controllers. The compound is also available as an accessory. See Table 5. Use the following procedure when installing the compound:

1. Fill the well with compound.
2. Coat the bulb generously before inserting it into the well.
3. Move the bulb up and down inside the well to ensure even distribution of compound.

Securing Bulb with Mounting Clamp

Use the 121371 Mounting Clamp *only* on wells with a mounting flange on the spud end.

1. Loosen the draw nut and spread the jaws of the clamp with a screwdriver. See Fig. 5.
2. Slide the clamp jaws over the spud mounting flange (point A in Fig. 5).
3. Adjust the tubing to fit through the mounting clamp groove (point B in Fig. 5).

IMPORTANT

When tightening the draw nut, be careful not to damage the capillary.

4. Tighten the draw nut so that the retainer clamp attaches firmly to the well spud and holds the tubing securely in place.

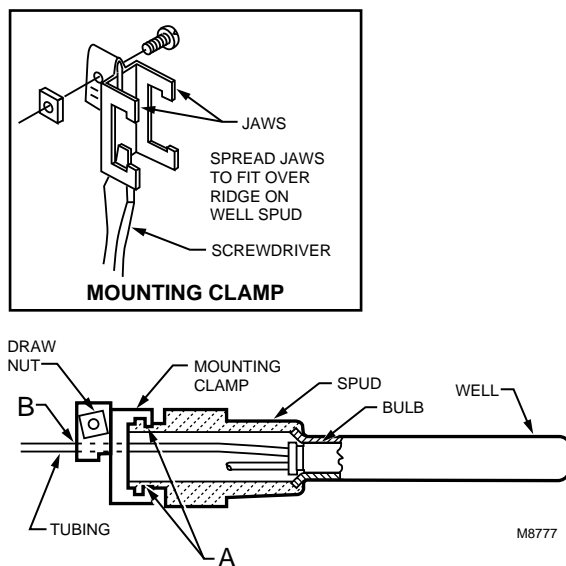

Fig. 5. Fastening bulb in well using mounting clamp.

Securing Bulb with Spring Clip

The spring clip can be used with any well with the appropriately size spud. Wells without a mounting flange on the spud require a spring clip.

NOTE: The spring clip does not hold the capillary as securely as does the mounting clamp. See Table 5 for spring clip part numbers.

1. Slide the clip over the capillary with the prongs facing the well.
2. Push the clip as far as possible into the spud. See Fig. 6.

NOTE: Make sure the bulb remains bottomed in the well.

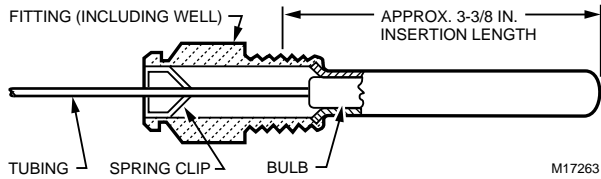

Fig. 6. Mounting spring clip into well spud.

Securing Bulb in Wells with Setscrew

Wells with a spud setscrew are designed for use with controllers that have armored capillary with a brass collar at the bulb end of the armor. The setscrew tightens against the brass collar. See Fig. 7. These wells can be adapted for use with 5/64 in. capillary by adding the 124904 Well Adapter and the 121371 Mounting Clamp Assembly. See Fig. 3.

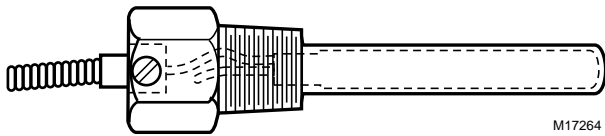

Fig. 7. Mounting armored capillary in well with setscrew.

Capillary Compression Fittings

1. Coat external spud threads with a moderate amount of pipe dope, leaving two end threads bare. See Fig. 4.

NOTE: Teflon tape can also be used.

2. Screw the spud into the tapping and tighten securely.
3. Place the packing nut on the tubing.
4. Slide the bulb completely through the fitting.
5. Place the composition disk and the four slotted brass washers on the tubing in the order shown in Fig. 8.
6. Turn the brass washers so that the slots are 180 degrees apart and the small tabs are in the mating slots.

7. Slide the seal assembly into the fitting. Make sure the sensing bulb extends the desired distance into the controlled medium. See Fig. 2.
8. Tighten the packing nut.

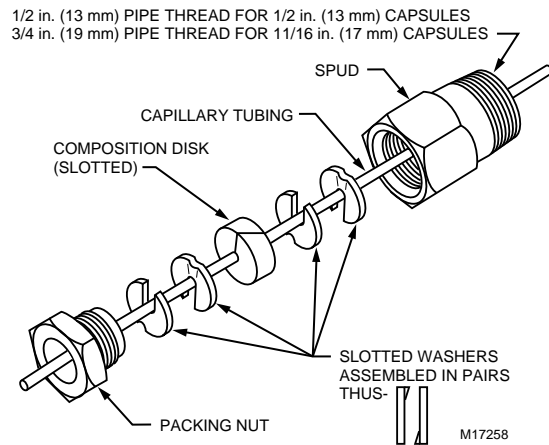

Fig. 8. Capillary compression fitting assembly.

Element Holders

Use element holders to mount air temperature sensors in a duct. Locate the sensing element where air at representative temperatures can circulate around it. In a plenum application, locate the element far enough from the combustion chamber to avoid the effect of direct radiation.

Bulb Holders

1. Cut a hole large enough to admit the bulb and holder in the duct or plenum at the mounting location.
2. Drill holes for the bulb holder mounting screws.
3. Mount the bulb and capillary on the holder. See Fig. 9 through 11.

107324A and 131524A Bulb Holders

Use these bulb holders to mount one bulb in a duct or plenum. See Fig. 9 and 10. If necessary, shorten holders by using pliers to flex the channel at one of the notches until it separates.

311266D Bulb Holder

Use this bulb holder to mount one or two bulbs in a duct where temperatures do not exceed 100°F (38°C). The removable plug in the mounting plate allows insertion of a thermometer to check duct air temperature. See Fig. 11 for installation details.

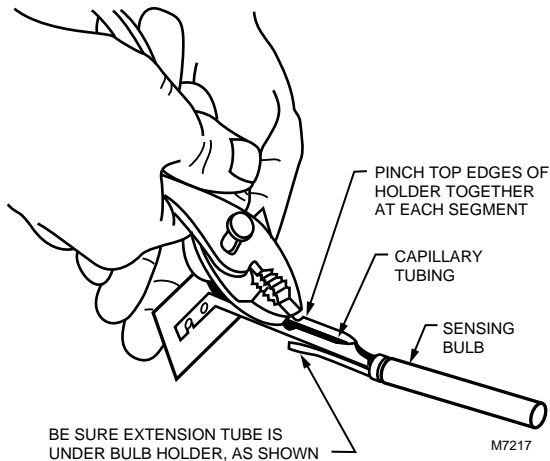

Fig. 9. Installing capillary in 107324A and 131524A Bulb Holders.

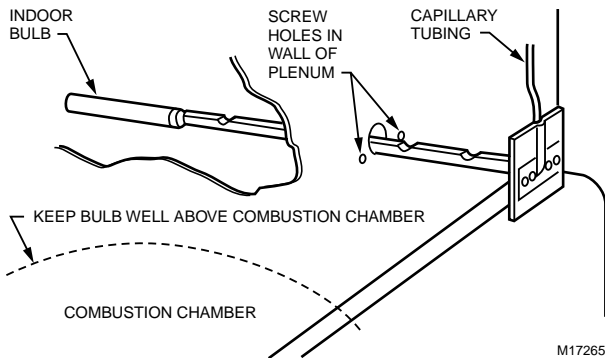

Fig. 10. Mounting bulb holder in furnace plenum.

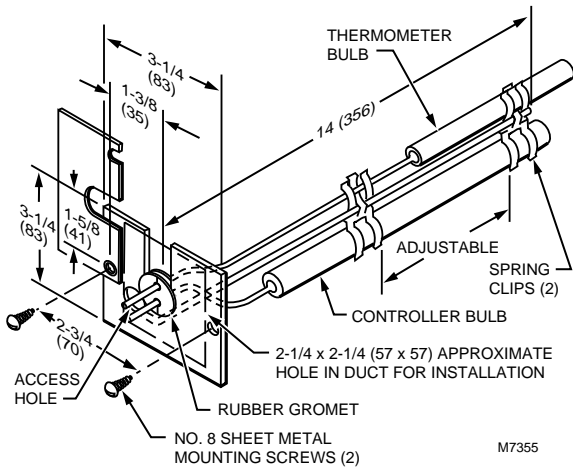

Fig. 11. Mounting sensing bulb and 311266D Bulb Holder in duct.

NOTE: Dimensions shown in in. (mm).

Duct Mounting with Capillary Compression Fitting

In some duct-mount application, it is desirable to use a compression fitting to reduce air leakage at the sensing element location. For these applications, first mount a waste nut on the duct to ensure secure mounting. See Fig. 12. See Table 6 for part numbers.

NOTE: Do not use this mounting method for liquid applications.

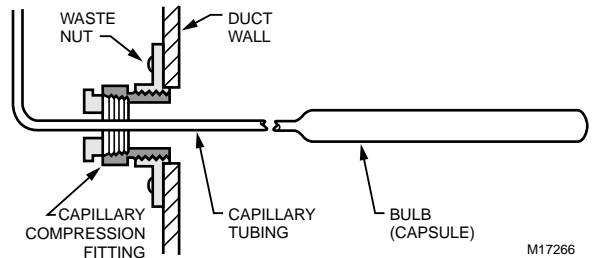

Fig. 12. Mounting sensing bulb in duct using waste nut and compression fitting.

Averaging Element Holders

The averaging element must be supported so it is distributed evenly across the entire height and width of the duct. It can be fastened to perforated strap iron (see Fig. 13) or mounted with 314439 Mounting Clips (see Fig. 14). This type of mounting requires threading the element through a grommet inserted in a hole in the duct wall.

For ducts with limited access, the 7640HX Averaging Element Mounting Kit allows mounting the element through a single hole in the side of the duct. This kit requires a length of 1/2 in. EMT conduit. See Fig. 15.

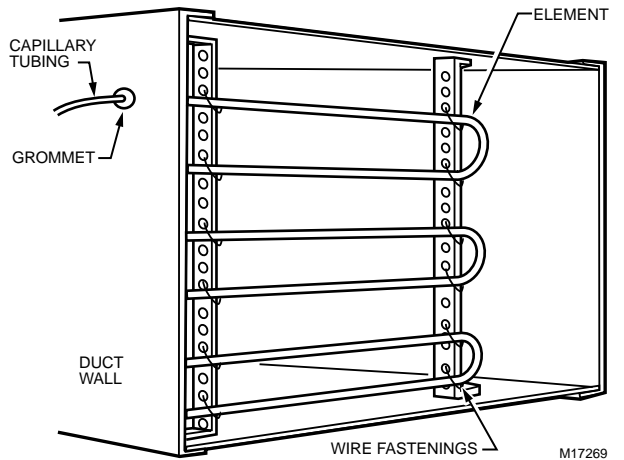

Fig. 13. Mounting averaging element with perforated strap iron.

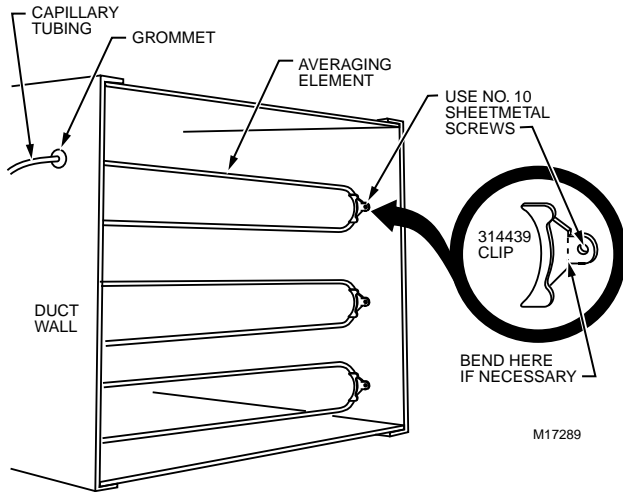

Fig. 14. Mounting averaging element with 314439 Mounting Clips.

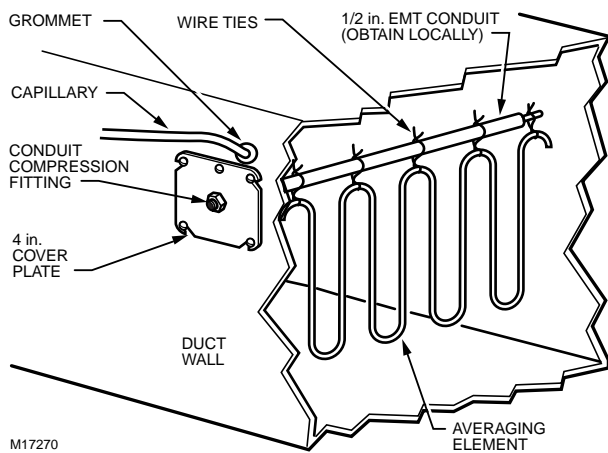

Fig. 15. Mounting averaging element with 7640HX Averaging Element Mounting Kit.

Bulb Shields

A bulb mounted outdoors requires protection of a bulb shield.

1. Expose the bulb to representative air temperature but not direct sunlight.
2. Mount it high enough so:
 - a. Accumulated snow, leaves or other debris cannot obstruct air circulation around it.
 - b. Children cannot reach it.
 - c. Avoid vents from the building.
3. Drill a 3/4 in. (19 mm) hole in the outside wall.
4. Bring the sensing bulb through the hole.
5. Mount the bulb in the bulb shield. See Fig. 16.
6. If the seal-off tube extends outside the shield, bend it under the shield.
7. Hold the shield over the mounting location and form a small-radius bend in the tubing.

8. Place the split plug (provided with 34886A; or order 107323A Split Plug separately) around the tubing and move the bulb and shield into mounting position as a single unit.
9. Push the split plug into the hole until it is wedged securely in place.
10. Fasten the shield on the wall with screws (provided with 34886A).
11. If the tubing is properly shaped and the split plug installed as directed, the shield covers the split plug and conceals the hole in the wall.

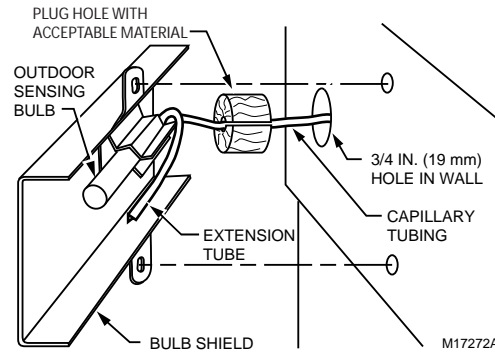

Fig. 16. Mounting bulb in bulb shield.

Strap-On Mounting

Occasionally, applications require the sensing bulb to be strapped to the outside of a pipe. For these applications, use either the 105900 Pipe Strap or metal hose clamps. The pipe strap fits pipe up to 3/4 in. OD.

External mounting of the sensor produces a slight offset in the temperature control point. Typically, the control temperature increases as much as 5°F (2.8°C) with a bare sensor strapped to the discharge pipe. Applying insulation around the sensor and pipe decreases the offset. Insulation must be used if large fluctuations in ambient temperature occur near the pipe.

Mount the bulb on the pipe as follows:



CAUTION

Significant Calibration Shift Hazard.
Overtightening clamps distorts bulb calibration.
 Do not overtighten hose clamps.

1. Secure the bulb to the pipe with a 105900 Pipe Strap or metal hose clamps. See Fig. 17 and 18.
2. If necessary, cover the bulb and pipe with foam rubber insulation that extends at least 6 in. (152 mm) beyond both ends of the bulb. See Fig. 19.

IMPORTANT

Do not allow the duct tape to come into contact with the pipe.

3. Secure foam rubber with duct tape.

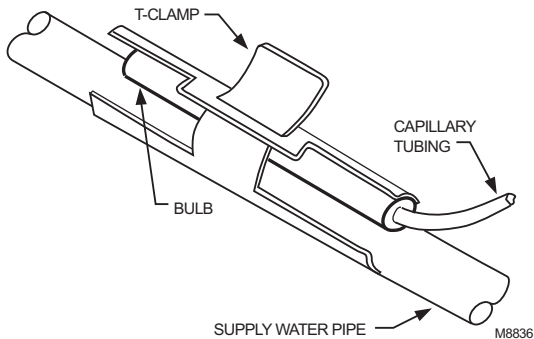

Fig. 17. Mounting bulb to pipe with pipe strap.

NOTE:When using a pipe strap, the maximum pipe OD is 3/4 in.

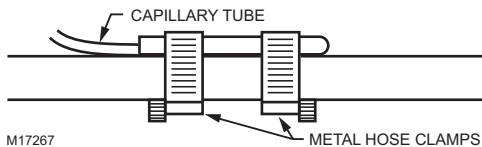

Fig. 18. Mounting bulb to pipe with metal hose clamps.

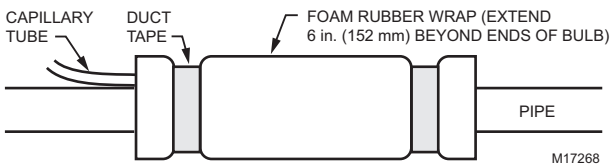

Fig. 19. Covering bulb and pipe with foam rubber insulation.

CHECKOUT

When installation is complete, check it as follows:

1. Visually inspect the fittings in hydronic applications for leakage.
2. If necessary, tighten these fittings.
3. Ensure excess capillary is coiled beneath the controller case.
4. Ensure proper operation by observing the system through one complete cycle.

CROSS REFERENCE

Some series 121371 Wells are also available without the mounting clamp. These pairs are listed together in Table 1 and in Table 7 for your convenience. The cross reference in Table 8 lists wells and fittings no longer available and suggests functional replacements.

Table 7. Wells With and Without Mounting Clamp.

121371 Part Number (With Clamp)	Part Number (Less Clamp)
121371A	123869A
121371B	123870A
121371M	123871A
121371N	123871B
121371P	None
121371Q	
121371L	123872A

Table 8. Cross Reference .

Old Part Number	Description	Replacement Part Number	Notes
121371G	Immersion well. Brass, 1/2-14 NPT, 1-1/2 in. insulation, 6-1/2 in. insertion, includes 121371 mounting clamp.	None	—
121371N	Immersion well. Copper, 3/4-14 NPT, 3 in. insulation, 3 in. insertion, includes plastic sleeve, 121371 mounting clamp.	123871B	No mounting clamp.
122555C	Immersion well. Copper, 3/4-14 NPT, 4-1/2 in. insulation, 5 in. insertion.	122555B	4-1/2 in. insulation plastic sleeve
122555F	Immersion well. Copper, 3/4-14 NPT, 4-1/2 in. insulation, 5 in. insertion, includes plastic sleeve, dual diameter bulb.	None	—
122555G	Immersion well. Copper, 3/4-14 NPT, 4-1/2 in. insulation, 5 in. insertion, dual diameter bulb.	None	—
123870E	Immersion well. Copper, 3/4-14 NPT, 1-1/2 in. insulation, 3 in. insertion, includes plastic sleeve, dual diameter capsule.	138134E	2-1/4 in. insulation.
123871D	Immersion well. Copper, 3/4-14 NPT, 3 in. insulation, 3 in. insertion, includes plastic sleeve, dual diameter well.	138134E	
123871E	Immersion well. Copper, 3/4-14 NPT, 3 in. insulation, 3 in. insertion, dual bulb.	138134C	
123872A	Immersion well. Copper, 1/2-14 NPT, 3 in. insulation, 3 in. insertion.	121371L	Includes mounting clamp.
104486B	Bulb compression fitting. Brass, 1/2-14 NPT.	104484A Capillary Compression Fitting or 1/2-14 NPT well with correct insertion length and diameter.	—
138134C	2-1/2 in. insulation	138134E	3-1/4 insulation
138134D	2-1/2 in. insulation	123871A	

Honeywell

Automation and Control Solutions

Honeywell
1985 Douglas Drive North
Golden Valley, MN 55422

Honeywell Limited-Honeywell Limitée
35 Dynamic Drive
Scarborough, Ontario
M1V 4Z9

Honeywell International

Control Products
Honeywell Building
17 Changi Business Park Central 1
Singapore 486073

Honeywell Europe S.A.

3 Avenue du Bourget
1140 Brussels
Belgium

Honeywell Latin American Region

480 Sawgrass Corporate Parkway
Suite 200
Sunrise FL 33325

