

INSTALLATION MANUAL

SINGLE ZONE SIDE-DISCHARGE HEAT PUMP

DRU1U18S2A, DRU1H18S2A, DRU1U24S2A, DRU1H24S2A,
DRU1U30S2A, DRU1H30S2A, DRU1U36S2A, DRU1H36S2A,
DRU1H42S2A, DRU1U48S2A, DRU1H48S2A, DRU1H49S2A,
DRU1U60S2A, DRU1H60S2A

R-454B, 208/230V, 1ph 60HZ, 24V / RS485 Communicating

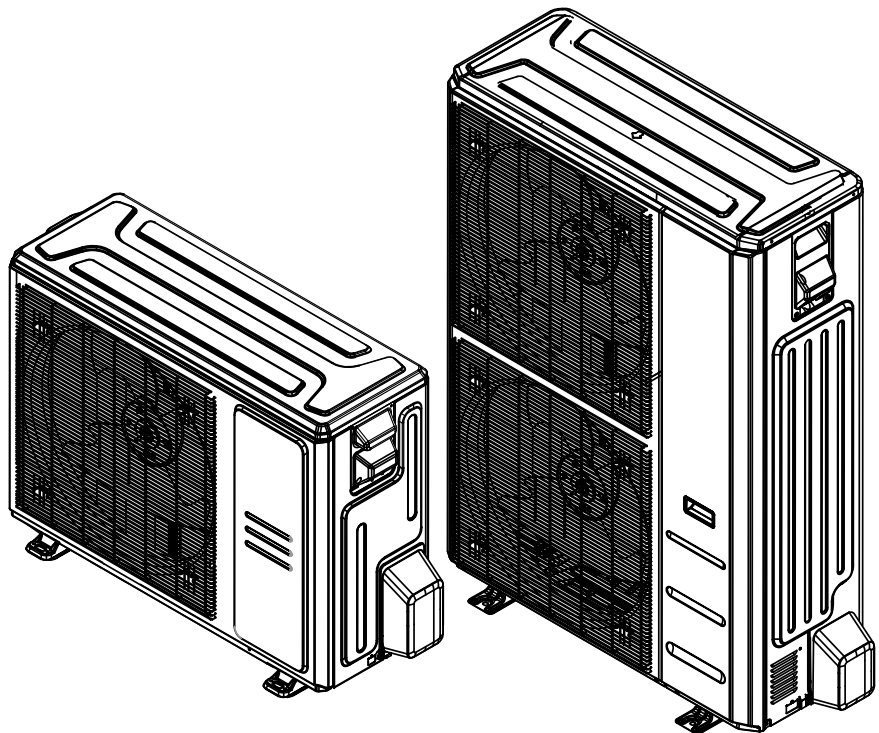

Model Number:

Serial Number:

Purchase Date:

Installing Contractor Company Name:



TIP

Capture relevant information about your Durastar mini-split equipment before it is installed and write it above for future reference.

TABLE OF CONTENTS

TABLE OF CONTENTS.....	2
INTRODUCTION	2
SYMBOLS USED IN THIS MANUAL.....	3
IMPORTANT SAFETY PRECAUTIONS	4
ACCESSORIES.....	11
PARTS IDENTIFICATION	12
SPECIFICATION OVERVIEW	12
OPERATING TEMPERATURES.....	13
OUTDOOR UNIT INSTALLATION.....	14
STEP 1: SELECT INSTALLATION LOCATION	14
STEP 2: INSTALL THE DRAIN JOINT	15
STEP 3: MOUNT THE OUTDOOR UNIT	16
REFRIGERANT PIPING CONNECTION.....	17
SYSTEM EVACUATION	24
WIRING THE OUTDOOR UNIT	25
CONTROL LOGIC	30
FINAL CHECKS.....	31
TEST RUN	32
TROUBLESHOOTING.....	33
LED DISPLAY.....	34
ERROR AND OPERATING CODES.....	35
WIRING DIAGRAMS.....	36
JOB SITE INFORMATION SHEET	41

INTRODUCTION

To better serve you, please do the following before contacting customer service:

- If you received a damaged product, immediately contact the retailer or dealer that sold you the product.
- Read and follow this manual carefully to install this air conditioner.
- Read the troubleshooting section of this manual as it will help you diagnose and solve common issues.
- Visit us on the web at **WWW.DURASTAR.COM** to download product guides and up-to-date information.
- If you need warranty service, our friendly customer service representatives are available via email at **QUESTIONS@DURASTAR.COM** or by telephone at **1-888-320-0706**.

SYMBOLS USED IN THIS MANUAL



WARNING: The warning symbol indicates personal injury or loss of life is possible. Extra care and precautions should be taken to ensure the user's safety.



CAUTION: The caution symbol indicates property damage or other serious consequences could occur.



NOTE: The pencil indicates any manufacturer notes relating to surrounding content. These may include further clarifications or call-outs.



TIP: A light bulb symbol indicates suggested manufacturer tips for the user to get the most out of the Durastar equipment and to accommodate the best user experience.



R-454B

A2L

Refrigerant
Safety Group
A2L

WARNING:

RISK OF FIRE DUE TO FLAMMABLE MATERIALS
Follow handling instructions carefully in compliance with national regulations.

Explanation of symbols displayed on the unit

	CAUTION	This symbol shows that the operation manual should be read carefully.
	CAUTION	This symbol shows that a service personnel should be handling this equipment with reference to the installation manual.
	CAUTION	
	CAUTION	This symbol shows that information is available such as the operating manual or installation manual.

**WARNING**

Turn off the air conditioner and disconnect the power before installing, cleaning, or repairing the air conditioner. Failure to do so can cause electric shock.

IMPORTANT SAFETY PRECAUTIONS

Improper handling can cause serious damage or injury. Please read the following safety information in its entirety.



Operation, Cleaning, and Maintenance Safety Precautions

- Children and people with reduced physical, sensory, or mental capabilities, or lack of experience and knowledge, should only use, clean, or maintain this air conditioner if they are given supervision or instructions concerning use of the air conditioner in a safe way and understand the hazards involved. Children should not play with the air conditioner.
- Maintenance or repair must be performed by qualified professionals. Otherwise, you may experience personal injury or damage to the air conditioner and surrounding property.
- Disconnect the power supply by turning it off at the circuit breaker when cleaning, maintaining, or repairing the air conditioner. Otherwise, you could risk electric shock.
- When turning the unit on or off via the emergency operation switch, press the switch with an insulated object other than metal.
- If the below problems occur, please turn off the air conditioner and disconnect power at the circuit breaker immediately. Then contact your dealer or a qualified professional for service.
 - The power cord is overheating or damaged.
 - There is an abnormal sound during operation.
 - The circuit breaker trips frequently.
 - The air conditioner gives off a burning smell.
 - The indoor unit is leaking.
- Do not block the air outlet or air inlet. This could cause a malfunction.
- Never stick fingers or any other body parts into the air conditioner openings. The internal fan may be rotating at high speeds, and may result in injury.
- Do not spill water on the remote control as this can permanently damage the remote.
- Do not spray water on the indoor unit. This could cause electric shock or a unit malfunction.
- Do not clean the air conditioner with excessive amounts of water.
- Do not clean the air conditioner with combustible cleaning agents; they can cause fire or deformation.
- After removing the filter, do not touch the fins in order to avoid injury.
- Do not use fire or a hair dryer to dry the filter. This could cause a deformation or fire hazard.
- Do not step on the top panel of the unit, or put heavy objects on the top panel. This could cause damage or personal injury.
- Do not use flammable materials such as hair spray, lacquer, or paint near the air conditioner as they may catch fire.
- Do not operate the air conditioner in places near combustible gases. Emitted gases may collect around the air conditioner and cause an explosion.
- Do not operate your air conditioner in a wet room such as a bathroom or laundry room. Too much exposure to water can cause electrical components to short circuit.
- If the air conditioner is used together with burners or other heating devices, thoroughly ventilate the room to avoid oxygen deficiency.



Electrical Safety

- Do not modify the length of the power supply cord or use an extension cord to power the unit.
- If the supply cord is damaged, it must be replaced by the manufacturer, a service agent, or a similarly qualified person in order to avoid a safety hazard.
- Keep power plug clean. Remove any dust or grime that accumulates on or around the plug. Dirty plugs can cause fire or electric shock.
- Do not pull power cord to unplug unit. Hold the plug firmly and pull it from the outlet. Pulling directly on the cord can damage it, which can lead to fire or electric shock.
- Do not share the electrical outlet with other appliances. Improper or insufficient power supply can cause fire or electrical shock.
- The product must be properly grounded at the time of installation, or electrical shock may occur.
- For all electrical work, follow all local and national wiring standards and regulations. Connect cables tightly, and clamp them securely to prevent external forces from damaging the terminal. Improper electrical connections can overheat and cause fire, and may also cause shock. All electrical connections must be made according to the Electrical Connection Diagram located on the panels of the indoor and outdoor units.
- All wiring must be properly arranged to ensure that the control board cover can close properly. If the control board cover is not closed properly, it can lead to corrosion and cause the connection points on the terminal to heat up, catch fire, or cause electrical shock.
- If connecting power to fixed wiring, an all-pole disconnection device which has at least 3mm clearances in all poles, and have a leakage current that may exceed 10mA, the residual current device(RCD) having a rated residual operating current not exceeding 30mA, and disconnection must be incorporated in the fixed wiring in accordance with the wiring rules.
- The air conditioner's circuit board (PCB) is designed with a fuse to provide over-current protection. The specifications of the fuse are printed on the circuit board.



Installation Safety

- Installation must be performed by an authorized dealer or specialist. Improper installation can cause water leakage, electrical shock, or fire. (In North America, installation must be performed in accordance with NEC and CEC requirements by authorized personnel only.)
- Installation must be performed according to the installation instructions. Improper installation can cause water leakage, electrical shock, or fire.
- This air conditioner shall be installed in accordance with national and local wiring regulations.
- Contact an authorized service technician for repair or maintenance of this unit.
- Only use the included accessories, parts, and specified parts for installation. Using non-standard parts can cause water leakage, electrical shock, fire, and can cause the unit to fail.
- Install the unit in a firm location that can support the unit's weight. If the chosen location cannot support the unit's weight, or the installation is not done properly, the unit may fall and cause serious injury and damage.
- Install drainage piping according to the instructions in the installation manual. Improper drainage may cause water damage to your home and property.
- For units that have an auxiliary electric heater, do not install the unit within 3 feet (1 meter) of any combustible materials.
- Do not install the unit in a location that may be exposed to combustible gas leaks. If combustible gas accumulates around the unit, it may cause a fire.

- Do not turn on the power until all work has been completed.
- When moving or relocating the air conditioner, consult experienced service technicians for disconnection and re-installation of the unit.
- Be careful when opening or closing valves below freezing temperatures. Refrigerant may spurt out from the gap between the valve stem and the valve body, resulting in injuries.

**WARNING: REFRIGERANT SAFETY (A2L)**

- Do not use means to accelerate the defrosting process or to clean the unit, other than those recommended by the manufacturer.
- The appliance shall be stored in a room without continuously operating ignition sources (for example: open flames, an operating gas appliance or an operating electric heater).
- Do not pierce or burn.
- Be aware that flammable refrigerants may not contain an odor.
- Compliance with national refrigerant regulations shall be observed.

**A2L REFRIGERANT SAFETY PRECAUTIONS****1. Installation (Where Refrigerant Pipes Are Allowed)**

- Any person who is involved with working on or breaking into a refrigerant circuit should hold a current valid certificate from an industry-accredited assessment authority, which authorizes their competence to handle refrigerants safely in accordance with an industry recognized assessment specification.
- Maintenance and repair requiring the assistance of other skilled personnel shall be carried out under the supervision of the person competent in the use of flammable refrigerants.
- That the installation of pipe-work shall be kept to a minimum.
- That pipe-work shall be protected from physical damage.
- Where refrigerant pipes shall be compliance with national gas regulations.
- That mechanical connections shall be accessible for maintenance purposes.
- Be more careful that foreign matter(oil, water,etc) does not enter the piping. Also, when storing the piping, securely seal the opening by pinching, taping, etc.
- All working procedure that affects safety means shall only be carried by competent persons.
- Appliance shall be stored in a well ventilated area where the room size corresponds to the room area as specific for operation.
- Joints shall be tested with detection equipment with a capability of 0.18 oz (5 g) per year of refrigerant or better, with the equipment in standstill and under operation or under a pressure of at least these standstill or operation conditions after installation. Detachable joints shall NOT be used in the indoor side of the unit (brazed, welded joint could be used).
- In cases that require mechanical ventilation, ventilation openings shall be kept clear of obstruction.

LEAK DETECTION SYSTEM installed. Unit must be powered except for service. For the unit with refrigerant sensor, when the refrigerant sensor detects refrigerant leakage, the indoor unit will display a error code and emit a buzzing sound, the compressor of outdoor unit will immediately stop, and the indoor fan will start running. The service life of the refrigerant sensor is 15 years. When the refrigerant sensor malfunctions, the indoor unit will display the error code "FHCC". The refrigerant sensor can not be repaired and can only be replaced by the manufacturer. It shall only be replaced with the sensor specified by the manufacturer.

2. Because a FLAMMABLE REFRIGERANT is used, the requirements for installation space of appliance and/or ventilation requirements are determined according to:

- the mass charge amount(M) used in the appliance,
- the installation location,
- the type of ventilation of the location or of the appliance.
- piping material, pipe routing, and installation shall include protection from physical damage in operation and service, and be in compliance with national and local codes and standards, such as ASHRAE 15, IAPMO Uniform Mechanical Code, ICC International Mechanical Code, or CSA B52. All field joints shall be accessible for inspection prior to being covered or enclosed.
- that protection devices, piping, and fittings shall be protected as far as possible against adverse environmental effects, for example, the danger of water collecting and freezing in relief pipes or the accumulation of dirt and debris;
- that piping in refrigeration systems shall be so designed and installed to minimize the likelihood of hydraulic shock damaging the system;
- that steel pipes and components shall be protected against corrosion with a rustproof coating before applying any insulation;
- that precautions shall be taken to avoid excessive vibration or pulsation;
- the minimum floor area of the room shall be mentioned in the form of a table or a single figure without reference to a formula;
- After completion of field piping for split systems, the field pipework shall be pressure tested with OXYGEN-FREE NITROGEN (OFN) and then vacuum tested prior to refrigerant charging, according to the following requirements:
 1. Pressure test the refrigerant piping to 500 PSI.
 2. The test pressure after removal of pressure source shall be maintained for at least 1 hour with no decrease of pressure indicated by the test gauge, with test gauge resolution not exceeding 5% of the test pressure.
 3. During the evacuation test, after achieving a vacuum level specified in the manual or less, the refrigeration system shall be isolated from the vacuum pump and the pressure shall not rise above 1500 microns within 10 min. The vacuum pressure level shall be specified in the manual, and shall be the lessor of 500 microns or the value required for compliance with national and local codes and standards, which may vary between residential, commercial, and industrial buildings.
- Field-made refrigerant joints indoors shall be tightness tested according to the following requirements: The test method shall have a sensitivity of 0.18 oz (5 g) per year of refrigerant or better under a pressure of at least 125% of the maximum allowable pressure. No leak shall be detected.

3 . Qualifications Of Workers

Any maintenance, service and repair operations must be performed by qualified personnel. Any working procedure that impacts safety must be performed only by qualified individuals who have completed the necessary training and obtained certification to demonstrate their competence. The training of these procedures is carried out by national training organizations or manufacturers that are accredited to teach the relevant national competency standards that may be set in legislation. All training shall follow the ANNEX HH requirements of UL 60335-2-40 4th Edition.

Examples for such working procedures are:

- breaking into the refrigerating circuit;
- opening of sealed components;
- opening of ventilated enclosures.

4. Ventilated Area

Ensure that the area is in the open or that it is adequately ventilated before breaking into the system or conducting any work that could produce ignition. Keep ventilation openings clear of obstruction. Ventilation continue during the period that the work is carried out. Proper ventilation should safely disperse any released refrigerant and preferably expel it externally into the atmosphere.

5. Cabling

Check that wiring will not be subject to wear, corrosion, excessive pressure, vibration, sharp edges or any other adverse environmental effects. The check shall also take into account the effects of aging or continual vibration from sources such as compressors or fans.

6. Detection Of Flammable Refrigerants

Under no circumstances shall potential sources of ignition be used in the searching for or detection of refrigerant leaks. A halide torch (or any other detector using a naked flame) shall not be used.

The following leak detection methods are deemed acceptable for refrigerant systems:

- Electronic leak detectors may be used to detect refrigerant leaks but, in the case of FLAMMABLE REFRIGERANTS, the sensitivity may not be adequate, or may need re-calibration to a sensitivity of 0.18 oz (5 g) per year. (Detection equipment shall be calibrated in a refrigerant free area.) Ensure that the detector is not a potential source of ignition and is suitable for the refrigerant used. Leak detection equipment shall be set at a percentage of the LFL of the refrigerant and shall be calibrated to the refrigerant employed, and the appropriate percentage of gas (25 % maximum) is confirmed.
- Leak detection fluids are also suitable for use with most refrigerants but the use of detergents containing chlorine shall be avoided as the chlorine may react with the refrigerant and corrode the copper pipe-work.

**Note**

Examples of leak detection fluids are bubble method and fluorescent method agents.

If a leak is suspected, all naked flames shall be removed/extinguished.

If a leakage of refrigerant is found which requires brazing, all of the refrigerant shall be recovered from the system, or isolated (by means of shut o valves) in a part of the system remote from the leak. See the following instructions for removal of refrigerant.

7. Evacuation

When breaking into the refrigerant circuit to make repairs – or for any other purpose conventional procedures shall be used. However, for flammable refrigerants it is important that best practice be followed, since flammability is a consideration.

The following procedure shall be adhered to:

- safely remove refrigerant following local and national regulations; evacuate;
- purge the circuit with NITROGEN
- evacuate (requirement);
- continuously flush or purge with NITROGEN when using flame to open circuit; and
- open the circuit

The refrigerant charge shall be recovered into the correct recovery cylinders if venting is not allowed by local and national codes. For appliances containing flammable refrigerants, the system shall be purged with OXYGEN-FREE NITROGEN (OFN) to render the appliance safe for flammable refrigerants. This process might need to be repeated several times. Compressed air or oxygen **shall not be used** for purging refrigerant systems.

For appliances containing flammable refrigerants, refrigerant purging shall be achieved by breaking the vacuum in the system with OXYGEN-FREE NITROGEN (OFN) and continuing to fill until the working pressure is achieved, then venting to atmosphere, and finally pulling down to a vacuum (requirement). This process shall be repeated until no refrigerant is within the system (requirement). When the final oxygen-free nitrogen charge is used, the system shall be vented down to atmospheric pressure to enable work to take place.

The outlet for the vacuum pump shall not be close to any potential ignition sources, and ventilation shall be available.

8. Recovery

When removing refrigerant from a system, either for servicing or decommissioning, it is recommended good practice that all refrigerants are removed safely.

When transferring refrigerant into cylinders, ensure that only appropriate refrigerant recovery cylinders are employed. Ensure that the correct number of cylinders for holding the total system charge is available. All cylinders to be used are designated.

9. Charging Procedures

In addition to conventional charging procedures, the following requirements shall be followed:

- Works shall be undertaken with appropriate tools only (In case of uncertainty, please consult the manufacturer of the tools for use with flammable refrigerants).
- Ensure that contamination of different refrigerants does not occur when using charging equipment.
- Hoses or lines shall be as short as possible to minimize the amount of refrigerant contained in them.
- Cylinders shall be kept upright.
- Ensure that the refrigeration system is grounded prior to charging the system with refrigerant.
- Label the system when charging is complete (if not already).
- Extreme care shall be taken not to overfill the refrigeration system.
- Prior to recharging the system it shall be pressure tested with OXYGEN FREE NITROGEN (OFN). The system shall be leak tested on completion of charging but prior to commissioning.
- A follow up leak test shall be carried out prior to leaving the site.



Additional Precautions

- Turn off the air conditioner and disconnect the power if you are not going to use it for a long time.
- Turn off the unit during electrical storms to avoid damaging the unit.
- Make sure that water condensation can drain unhindered from the unit.
- Do not operate the air conditioner with wet hands. This may cause electric shock.
- Do not use this device for any other purpose than its intended use.
- Do not climb onto or place objects on top of the outdoor unit.
- Do not allow the air conditioner to operate for long periods of time with doors or windows open, or if the humidity is very high.

Specifications of R-454B Refrigerant

- **Application: R-454B is not a drop-in replacement for R-410A.** The equipment design must accommodate the A2L safety group of R-454B. It cannot be used in R-410A systems.
- **Physical Properties:** R-454B has an atmospheric bubble point of -59.6 °F (-50.9 °C) and an atmospheric dew point of -58.0 °F (-50.0 °C). Its bubble point saturation pressure at 77 °F (25 °C) is 213 psig (1469 kPa) and dew point saturation pressure at 77 °F (25 °C) is 205 psig (1415 kPa).
- **Composition:** R-454B is classified as safety group A2L per ASHRAE Standard 34. Verify that service equipment and instruments are certified for use with group A2L refrigerants, and in particular with R-454B is a non-azeotropic mixture of 68.9% by weight difluoromethane (HFC-32) and 31.1 % by weight 2,3,3,3-tetrafluoro-1-propene (HFO-1234yf).

R454B REQUIRED MINIMUM ROOM AREA

Minimum Room Area

R454B UL guidelines require dissipation if there is a refrigerant leak and are based on total square footage and total system charge. The total system charge includes any component that holds refrigerant, including line sets, indoor coils, and outdoor units. The minimum room area for operating and storing the unit should be as specified in the following table.

TA_{min} : REQUIRED MINIMUM ROOM AREA: ft² (m²)

M _c or M _{REL} [oz/kg]	TA _{min} [ft ² /m ²]	M _c or M _{REL} [oz/kg]	TA _{min} [ft ² /m ²]	M _c or M _{REL} [oz/kg]	TA _{min} [ft ² /m ²]	M _c or M _{REL} [oz/kg]	TA _{min} [ft ² /m ²]
≤ 62.7/1.7	12/1.1	134/3.8	126/11.67	211.6/6.0	198/18.43	289.2/8.2	271/25.18
63.5/1.8	60/5.53	141.1/4	132/12.29	218.7/6.2	205/19.04	296.3/8.4	278/25.8
70.5/2	66/6.14	148.1/4.2	139/12.9	225.8/6.4	212/19.66	303.4/8.6	284/26.41
77.6/2.2	73/6.76	155.2/4.4	145/13.51	232.8/6.6	218/20.27	310.4/8.8	291/27.63
84.6/2.4	79/7.37	162.2/4.6	152/14.13	239.9/6.8	225/20.88	317.5/9.0	298/27.64
91.7/2.6	86/7.99	169.3/4.8	159/14.74	246.9/7.0	231/21.5	324.5/9.2	304/28.26
98.8/2.8	93/8.6	176.4/5	165/15.36	254/7.2	238/22.11	331.6/9.4	311/28.87
105.8/3	99/9.21	183.4/5.2	172/15.97	261/7.4	245/22.73	338.6/9.6	317/29.48
112.9/3.2	106/9.83	190.5/5.4	179/16.58	268.1/7.6	251/23.34	345.7/9.8	324/30.10
119.9/3.4	112/10.44	197.5/5.6	185/17.2	275.1/7.8	258/23.96	352.7/10.0	331/30.71
127/3.6	119/11.06	204.6/5.8	192/17.81	282.2/8.0	264/24.57		
Variable Definitions	<p>TA_{min}: the required minimum room area in ft² (m²) M_c: the actual refrigerant charge in the system in lbs (kg) M_{REL}: the refrigerant releasable charge in lbs (kg)</p> <p>WARNING: The minimum room area or the minimum room area of conditioned space is based on releasable charge and total system refrigerant charge.</p>						

ACCESSORIES

INCLUDED INSTALLATION ACCESSORIES

The air conditioning system comes with the following accessories.

Accessory	Quantity	Image	Accessory	Quantity	Image
Installation Manual	1		Rubber Foot	4	
Drain Joint	1		Drain Joint Seal (Depending on Drain Joint Type)	0 - 1	
Braze To Flare Adapter	2		5/8" -> 3/4" Flare Adapter For DRU1U18S2A	1	

FIELD SUPPLIED INSTALLATION ACCESSORIES

The following installation accessories may be required and must be purchased separately.

- Refrigerant piping (line set)
- Indoor and outdoor connection wire
- Outdoor power supply cord
- Drain pipe
- Pipe and cable wrapping tape
- Wall hole sleeve and cover
- Putty
- Wiring u-lugs

WARNING



Ensure that all service equipment and instruments are certified for use with group A2L refrigerants, specifically R-454B. Recovery equipment, pumps, hoses, and related components must be rated for the appropriate design pressures for R-454B. Manifold sets should accommodate pressures up to 800 psig on the high side and 250 psig on the low side, with a 550 psig low-side retard. Hoses must have a service pressure rating of 800 psig, while recovery cylinders should be rated for 400 psig, meeting DOT 4BA400 or DOT 4BW400 standards.

TOOLS NEEDED

The following tools are required for installation.

- Phillips screwdriver
- Drill with 2 1/2" or 3 1/2" (indoor unit model depending) core bit
- Vacuum pump
- HVAC manifold gauge set
- Micron Gauge
- Refrigerant leak detector
- Copper pipe cutter
- Flaring tool
- Burr reamer
- Crescent or spanner wrench
- Hexagonal wrench set
- Torque wrench
- Multimeter
- Electroprobe
- Level
- Hammer
- Wire strippers
- Wire crimper

PARTS IDENTIFICATION



NOTE

The installation must be performed in accordance with the required local and national standards. The installation may be slightly different in different areas.

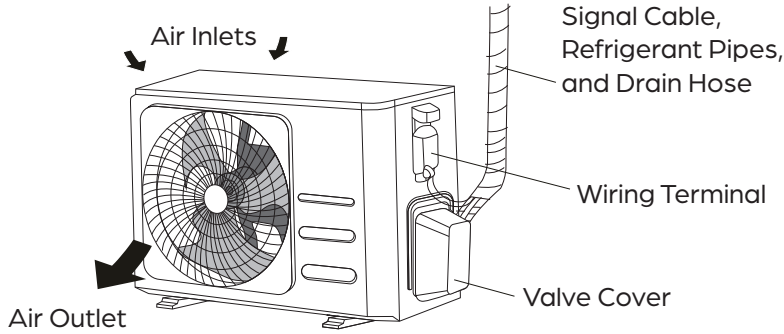

NOTE

Illustrations in this manual are for explanatory purposes. The actual shape of your mini-split equipment may vary slightly.

SPECIFICATION OVERVIEW

The table below includes basic specifications for this unit. For more detailed specifications please refer to the submittals on DURASTAR.COM. Durastar reserves the right to change specifications without notice.

MODEL	BTUH	VOLTAGE (V)	MCA (A)	MOC P (A)	LIQUID PIPE (in (mm))	SUCTION PIPE (in (mm))	NET WEIGHT (lbs (kg))
DRU1U18S2A	18,000	208/230	16	20	3/8 (9.52)	3/4 (19)*	77 (35)
DRU1H18S2A	18,000	208/230	17	20	3/8 (9.52)	3/4 (19)	102 (46)
DRU1U24S2A	24,000	208/230	19	20	3/8 (9.52)	3/4 (19)	102 (46)
DRU1H24S2A	24,000	208/230	19	20	3/8 (9.52)	3/4 (19)	102 (46)
DRU1U30S2A	30,000	208/230	23	25	3/8 (9.52)	3/4 (19)	142 (64)
DRU1H30S2A	30,000	208/230	29.5	30	3/8 (9.52)	3/4 (19)	164 (74)
DRU1U36S2A	36,000	208/230	27	30	3/8 (9.52)	3/4 (19)	153 (70)
DRU1H36S2A	36,000	208/230	32	35	3/8 (9.52)	3/4 (19)	204 (93)
DRU1H42S2A	42,000	208/230	38	40	3/8 (9.52)	3/4 (19)	201 (91)
DRU1U48S2A	48,000	208/230	36	40	3/8 (9.52)	3/4 (19)	193 (88)
DRU1H48S2A	48,000	208/230	38	40	3/8 (9.52)	3/4 (19)	201 (91)
DRU1H49S2A	48,000	208/230	40	40	3/8 (9.52)	3/4 (19)	243 (110)
DRU1U60S2A	60,000	208/230	39	40	3/8 (9.52)	3/4 (19)	193 (88)
DRU1H60S2A	60,000	208/230	40	40	3/8 (9.52)	3/4 (19)	243 (110)

*Included adapter must be used with the DRU1U18S2A to match the air handler suction pipe size

OPERATING TEMPERATURES

Your air conditioner is designed to operate in the following indoor and outdoor temperatures. When your air conditioner is used outside of the following temperature ranges, certain safety features may activate and turn off the unit to protect it from damage.

TEMPERATURE RANGES

	COOL mode	HEAT mode	DRY mode
Indoor Air Temperature	60°F - 90°F (16°C - 32°C)	32°F - 86°F (0°C - 30°C)	50°F - 90°F (10°C - 32°C)
Outdoor Air Temperature	-13°F / -22°F* - 122°F (-25°C / -30°C* - 50°C)	-13°F / -22°F* - 75°F (-25°C / -30°C* - 24°C)	32°F - 122°F (0°C - 50°C)

* The minimum operating temperature depends on the outdoor unit. Low ambient Sirius Heat™ models have a minimum operating temperature in heat mode of -22°F (-30°C).

To further optimize the performance of your unit, do the following:

- Keep doors and windows closed.
- Limit energy usage by using TIMER ON and TIMER OFF features.
- Do not block air inlets or outlets.
- Regularly inspect and clean air filters.

NOTE

 Your Durastar heat pump outdoor unit is equipped with a base pan heater, allowing it to continue to operate at freezing temperatures as low as -22°F (-30°C). When outdoor air temperatures are at or below 32°F (0°C), we strongly recommend keeping the unit plugged in at all times to ensure smooth ongoing performance.

NOTE

 Keep the room's relative humidity below 80%. If the air conditioner operates in excess of this, the surface of the air conditioner may attract condensation. To help prevent condensation from forming and dripping, set the vertical airflow louver to its maximum angle (vertically to the floor) and set the fan to HIGH.

OUTDOOR UNIT INSTALLATION

Installation Instructions

Install the unit following local codes and regulations. These may differ slightly between regions.

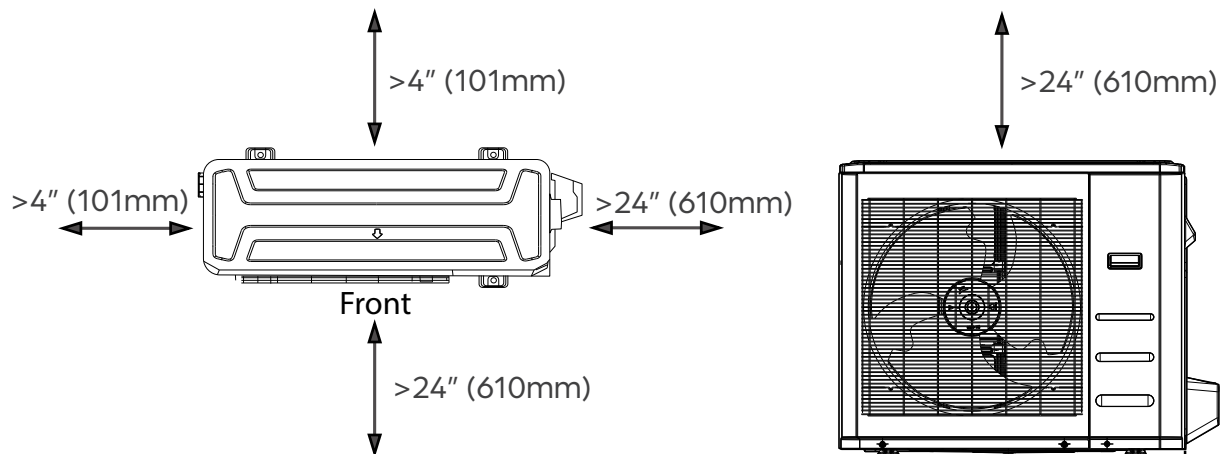

STEP 1: SELECT INSTALLATION LOCATION

Before installing the outdoor unit, you must choose an appropriate location. The following are standards that will help you choose an appropriate location for the unit.

Proper installation locations meet the following standards:

- Meets all spatial requirements shown in installation space requirements above.
- Good air circulation and ventilation.
- Firm and solid location —the location can support the unit's weight and will not vibrate.
- Noise from the unit will not disturb others.
- Protected from prolonged periods of direct sunlight or rain.



NOTE

Where snowfall is anticipated, raise the unit above the base pad to allow free drainage to prevent ice buildup and coil damage. Mount the unit high enough to be above the average accumulated area snowfall. The minimum height must be 18 inches.

DO NOT install unit in the following locations:

- Near an obstacle that will block air inlets and outlets.
- Near a public street, crowded areas, or where noise from the unit will disturb others.
- Near animals or plants that will be harmed by hot air discharge.
- Near any flammable items or source of combustible gas.
- In a location that is exposed to large amounts of dust.
- In a location exposed to an excessive amount of salty air.
- In a location 10 ft. (3 m) or closer to TV or radio antennas. Operation of the unit may interfere with antenna reception in areas where the signal is weak. An amplifier may be needed for affected devices.



NOTE

If a line set is not already installed, keep in mind the positioning of the line set before mounting the unit.

Special considerations for extreme weather

If the unit is exposed to heavy wind, install unit so that the air outlet fan is at a 90° angle to the direction of the wind. If needed, build a barrier in front of the unit to protect it from extremely heavy winds. See figures below.

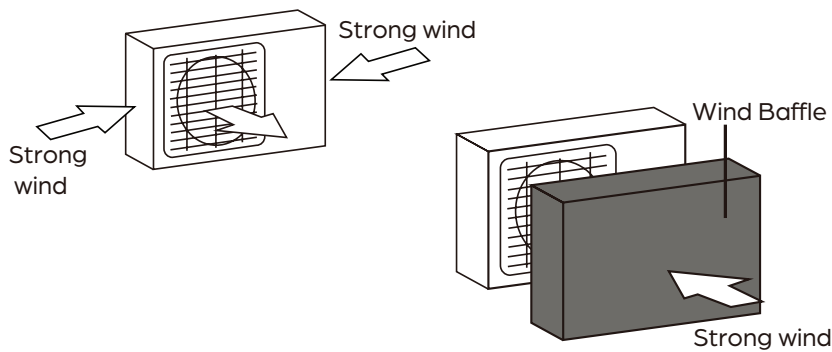

If the unit is frequently exposed to heavy rain or snow

Build a shelter above the unit to protect it from rain or snow. Be careful not to obstruct airflow around the unit.

STEP 2: INSTALL THE DRAIN JOINT

1. Fit the rubber seal on the end of the drain joint that will connect to the outdoor unit.
2. Insert the drain joint into the hole in the base pan of the unit.
3. Rotate the drain joint 90° until it clicks in place facing the front of the unit.
4. Connect a drain hose extension (not included) to the drain joint to redirect water from the unit during heating mode.

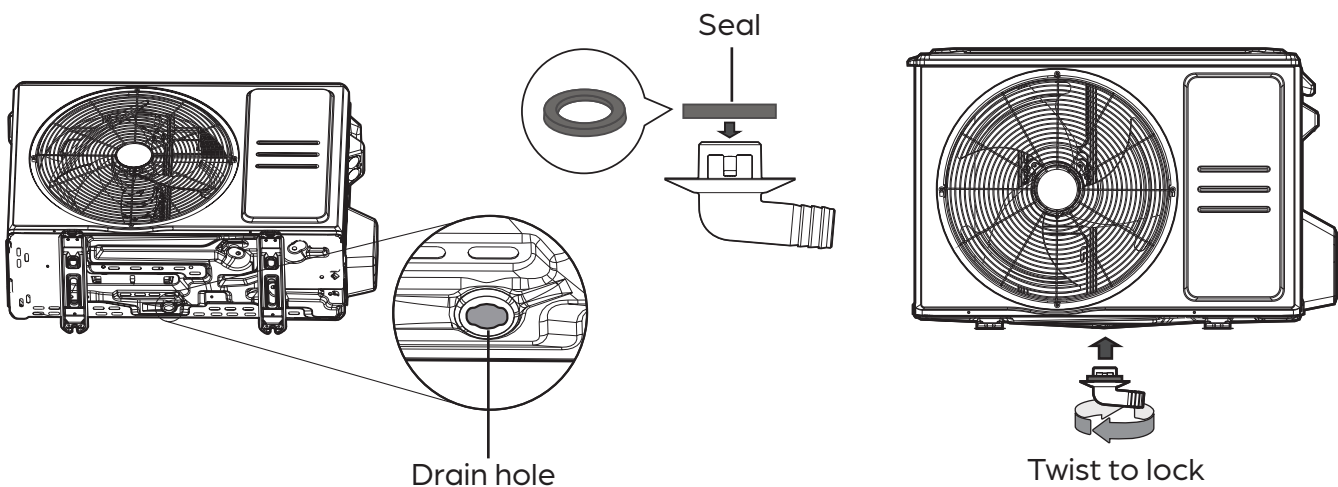

NOTE

In cold climates, make sure that the drain hose is as vertical as possible to ensure swift water drainage. If water drains too slowly, it can freeze in the hose and flood the unit.

STEP 3: MOUNT THE OUTDOOR UNIT

NOTE
The unit should be mounted or raised above the maximum snowfall depth of the region.

Anchoring the Unit

The outdoor unit can be anchored to the ground or to a wall-mounted bracket (sold separately) with bolts (M10). Mount the unit on a cement slab, condenser mounting pad, or other level surface able to support the unit's weight. **Do not place the unit directly on the ground.** If using a wall-mounting bracket, make sure the attached structure can support at least four times the unit's weight.

Unit Mounting Dimensions

The distance between their mounting feet varies by outdoor unit. Prepare the installation base of the unit according to the dimensions below. In most cases, it may be easier to place the outdoor unit in its correct location and mark the exact placement for the anchor holes.

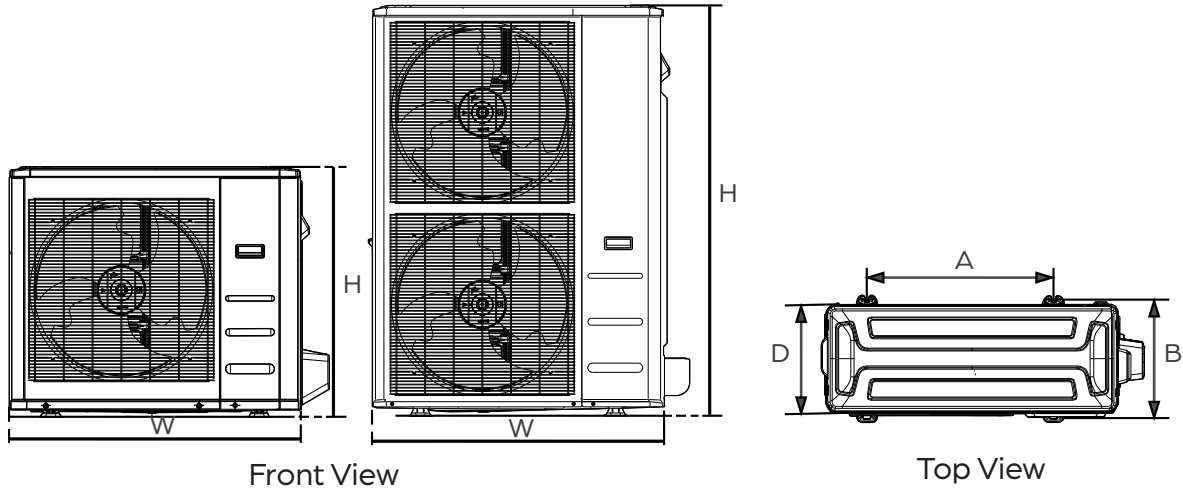

Front View

Top View

MODEL	OUTDOOR UNIT DIMENSIONS						MOUNTING DIMENSIONS			
	W		H		D		A		B	
	inch	mm	inch	mm	inch	mm	inch	mm	inch	mm
DRU1U18S2A	31-11/16	805	21-13/16	554	13	330	20-1/8	511	12-1/2	317
DRU1H18S2A	35	890	26-1/2	673	13-7/16	342	26-1/8	663	13-15/16	354
DRU1U24S2A	35	890	26-1/2	673	13-7/16	342	26-1/8	663	13-15/16	354
DRU1H24S2A	35	890	26-1/2	673	13-7/16	342	26-1/8	663	13-15/16	354
DRU1U30S2A	37-1/4	946	31-15/16	810	16-3/16	410	26-1/2	673	15-7/8	403
DRU1H30S2A	37-1/4	946	31-15/16	810	16-3/16	410	26-1/2	673	15-7/8	403
DRU1U36S2A	37-1/4	946	31-15/16	810	16-3/16	410	26-1/2	673	15-7/8	403
DRU1H36S2A	38-9/16	980	38-3/8	975	16-3/8	415	24-1/4	616	15-5/8	397
DRU1H42S2A	38-9/16	980	38-3/8	975	16-3/8	415	24-1/4	616	15-5/8	397
DRU1U48S2A	38-9/16	980	38-3/8	975	16-3/8	415	24-1/4	616	15-5/8	397
DRU1H48S2A	38-9/16	980	38-3/8	975	16-3/8	415	24-1/4	616	15-5/8	397
DRU1H49S2A	37-1/2	952	52-1/2	1333	16-3/8	415	24	634	15-15/16	404
DRU1U60S2A	38-9/16	980	38-3/8	975	16-3/8	415	24-1/4	616	15-5/8	397
DRU1H60S2A	37-1/2	952	52-1/2	1333	16-3/8	415	24	634	15-15/16	404

Installing multiple outdoor units

If installing multiple outdoor units, refer to the diagram below for proper airflow clearances. Please note it is still recommended to leave 24" between units for service.

H = Outdoor unit height
 L = Wall / Obstruction height
 A = Required distance between unit and wall / obstruction

	L	A
L ≤ H	L ≤ 1/2H	≥ 9 13/16" (250mm)
	1/2H < L ≤ H	≥ 11 13/16" (300mm)
L > H	Can not be installed	

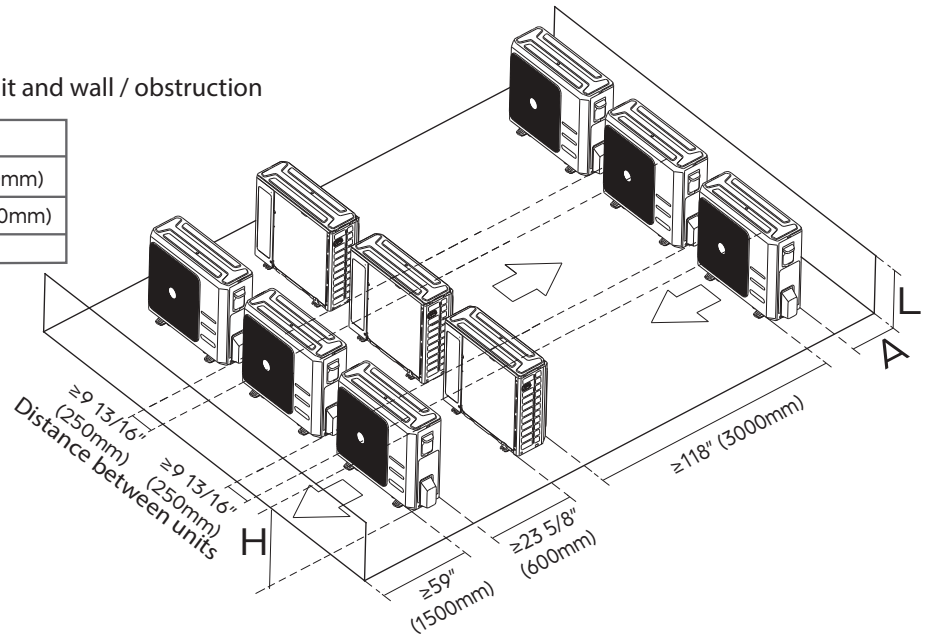

REFRIGERANT PIPING CONNECTION

All field piping must be completed by a licensed technician and must comply with the local and national regulations.

In the event of refrigerant leakage, measures should be taken to prevent the refrigerant concentration in the room from exceeding the safe limit. If the refrigerant leaks and its concentration exceeds its proper limit, hazards due to lack of oxygen may result. Ventilate the area immediately.

WARNING



When connecting refrigerant piping, do not let substances or moisture other than specified refrigerant enter the unit or pipes. Run nitrogen through the refrigerant tubing when brazing to avoid carbon build up. The presence of foreign materials will lower the unit's capacity and can cause abnormally high pressure in the refrigeration system. This can result in explosion and personal injury.

REFRIGERANT PIPE LENGTH

The length of refrigerant piping will affect the performance and efficiency of the unit. Nominal efficiency is tested with a pipe length of 25 feet (7.6 meters). A minimum pipe run of 10 feet (3 meters) is required to minimize vibration and excessive noise.

ADDING ADDITIONAL REFRIGERANT

Each outdoor unit is factory charged with enough refrigerant to support up to 25' (7.5m) per zone. This is based on a one way liquid line measurement from the outdoor unit to the indoor unit. Systems with line sets that exceed this length will require additional refrigerant (see the following chart). The refrigerant should be charged from the service port on the outdoor unit's low pressure valve. Additional refrigerant information can be found in the **SUBMITTAL DOCUMENTS** at **WWW.SERVICE.DURASTAR.COM**. Additional refrigerant can be calculated using the following chart and formula:

$$(\text{Actual pipe length} - \text{Standard pipe length}) \times \text{Additional Refrigerant Charge}$$



WARNING

DO NOT mix refrigerant types.

REFRIGERANT PIPING SPECIFICATIONS

Capacity	Standard Refrigerant Connection Size	Standard Pipe Length w/ Precharged Refrigerant	Additional Refrigerant Charge		Maximum Length of Piping	Maximum Rise Length
			1/4 Liquid Line	3/8 Liquid Line		
			oz/ft (g/m)	oz/ft (g/m)		
18k	3/8 x 3/4	25 (7.6)	0.32 (30)	0.69 (65)	98.4 (30)	65.6 (20)
24k / 30k	3/8 x 3/4	25 (7.6)	0.32 (30)	0.69 (65)	164 (50)	82 (25)
36k / 42k / 48k / 60k	3/8 x 3/4	25 (7.6)	0.32 (30)	0.69 (65)	246 (75)	98.4 (30)



NOTE

Adapters are included with the indoor unit and outdoor unit to convert the flared fittings to brazed if necessary.



IMPORTANT NOTE:

The TOTAL SYSTEM CHARGE WEIGHT should be noted on the label adjacent to the unit rating label on the outdoor unit.

SUCTION LINE SIZE AND COOLING CAPACITY LOSSES

NOTE
 The length of the line set will effect the capacity. Units are rated with a 25' line set per AHRI requirements. If needed, alternative suction line sizes can be utilized according to the chart below. The capacity loss percentages are estimates.

Unit Nominal Size (BTUH)	Liquid Line Diameters (In. OD)	Suction Line Diameters (In. OD)	COOLING CAPACITY LOSS (%)								
			Total Equivalent Line Length ft. (m)								
			26-50 (7.9-15.2)	51-80 (15.5-24.4)	81-100 (24.7-30.5)	101-125 (30.8-38.1)	126-150 (38.4-45.7)	151-164 (46.0-50.0)	165-213 (50.2-65.0)	214-225 (65.3-68.6)	226-250 (68.9-76.2)
18000	3/8	1/2	2	4	6	NA	NA	NA	NA	NA	NA
		5/8	1	2	3	NA	NA	NA	NA	NA	NA
		3/4	0	1	2	NA	NA	NA	NA	NA	NA
24000	3/8	5/8	1	2	3	5	7	8	NA	NA	NA
		3/4	0	1	2	3	4	4	NA	NA	NA
		7/8	0	1	1	2	2	3	NA	NA	NA
30000	3/8	5/8	1	2	3	4	5	5	NA	NA	NA
		3/4	0	1	1	2	2	3	NA	NA	NA
		7/8	0	0	1	1	1	2	NA	NA	NA
36000	3/8	5/8	2	3	4	5	7	7	10	11	12
		3/4	1	1	2	2	3	4	5	5	6
		7/8	0	1	1	1	2	2	3	3	4
48000	3/8	3/4	1	2	3	4	5	5	7	8	9
		7/8	0	1	1	2	3	3	4	5	5
		11/8	0	0	0	1	1	1	2	2	3
60000	3/8	3/4	1	2	3	4	6	6	8	9	10
		7/8	0	1	2	2	3	3	5	5	6
		11/8	0	0	0	1	1	1	2	2	3

OIL TRAPS

Oil traps are necessary for the continued performance of the system if the indoor and outdoor units are installed at significantly different heights.



CAUTION
 If oil flows back into the outdoor unit's compressor, this might cause liquid compression or deterioration of oil return. Oil traps in the rising gas piping can prevent this.

If the unit is **less than** 36000Btu/h an oil trap should be installed every 20ft (6m) of vertical suction line rise.

If the unit is **greater than** 36000Btu/h an oil trap should be installed every 32.8ft (10m)of vertical suction line rise.

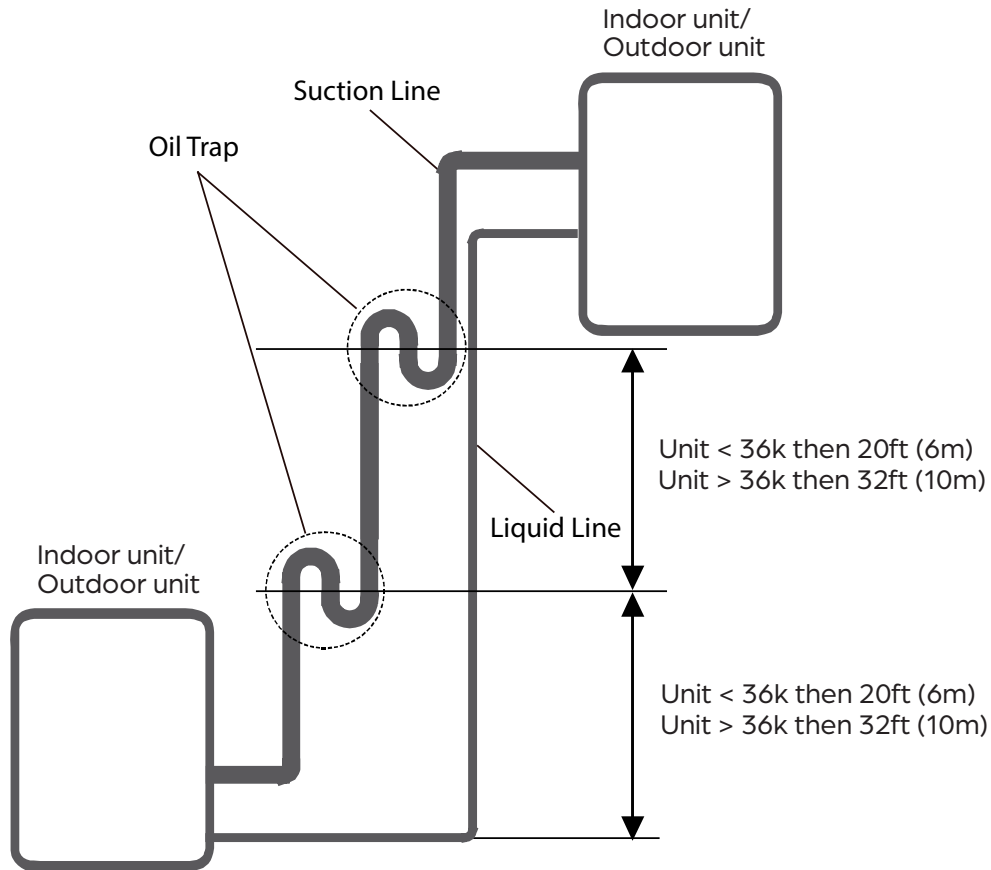

REFRIGERANT PIPE CONNECTION INSTRUCTIONS

STEP 1: CUT PIPES

When preparing refrigerant pipes, take extra care to cut and flare them properly. This will ensure efficient operation and minimize leaks and the need for future maintenance.

1. Measure the distance between the indoor and outdoor units.
2. Using a pipe cutter, cut the pipe length a little longer than the measured distance.
3. Make sure that the pipe is cut at a perfect 90° angle.
4. Do not damage, deform, or dent the pipe while cutting.

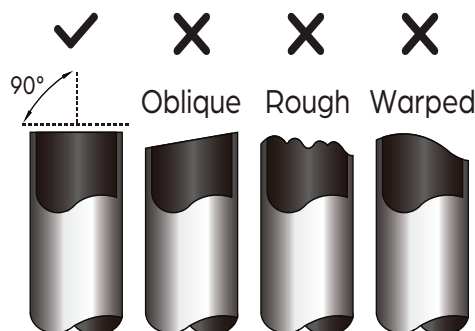

STEP 2: REMOVE BURRS

Burrs can affect the airtight seal of the refrigerant piping connection and must be completely removed.

1. Hold the pipe at a downward angle to prevent burrs from falling into the pipe.
2. Using a reamer or deburring tool, remove all burrs from the cut section of the pipe.

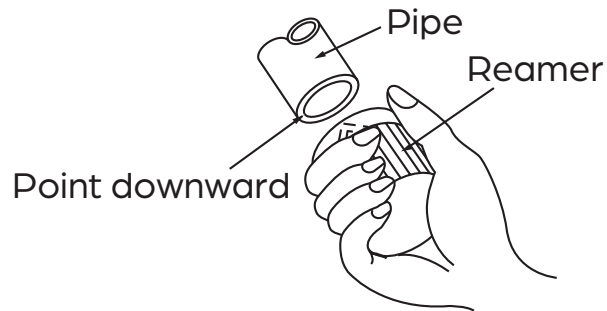

STEP 3: FLARE PIPE ENDS

Proper flaring is essential to achieve an airtight seal.

1. After removing burrs from cut pipe, seal the ends with PVC tape to prevent foreign materials from entering the pipe.
2. Sheath pipe with insulating material.
3. Place flare nuts on both ends of the pipe. Make sure they are facing in the right direction as you cannot change their orientation after flaring.

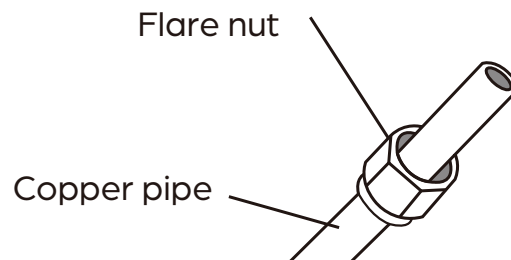

4. Remove PVC tape from ends of pipe when ready to perform flaring.
5. Clamp flare form on the end of pipe. The end of the pipe must extend beyond the edge of the flare form in accordance with the pipe extension table on the next page.

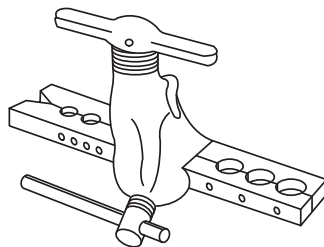

PIPE EXTENSION BEYOND FLARE FORM

Outer Diameter of Pipe Inches (mm)	"A" Minimum Extension Inches (mm)	"A" Maximum Extension Inches (mm)
∅ 3/8" (9.5mm)	0.04" (1.0mm)	0.063" (1.6mm)
∅ 5/8" (15.9mm)	0.078" (2.0mm)	0.086" (2.2mm)
∅ 3/4" (19.1mm)	0.078" (2.0mm)	0.094" (2.4mm)

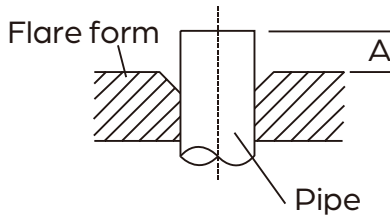

TIP: THICKNESS COMPARISON

- 0.04" = A Dime
- 0.078" = A Nickle

- Place flaring tool onto the form.
- Turn the handle of the flaring tool clockwise until the pipe is fully flared.
- Remove the flaring tool and flare form, then inspect the pipe for cracks and even flaring.

STEP 4: CONNECT PIPES

When connecting refrigerant pipes, be careful not to use excessive torque or to deform the piping in any way. You should first connect the low-pressure pipe, then the high-pressure pipe.

When bending connective refrigerant piping, the minimum bending radius is 4 inches (10cm). Do not leave coils in the refrigerant line sets. Remove excess line length to ensure proper system operation.

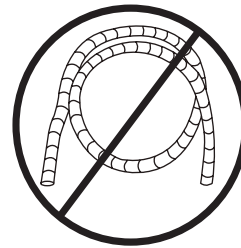
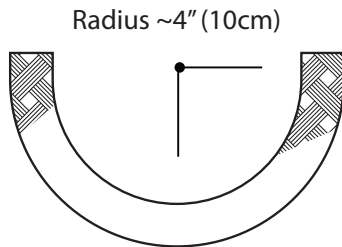

WARNING

Do not leave coils in the refrigerant line sets. All excess line length must be removed to ensure proper system operation.

CONNECTING PIPING TO INDOOR UNIT



NOTE

It is advised to install a 3/8 **bi-flow** drier on the liquid line near the indoor unit.

- Align the center of the two pipes that you will connect.

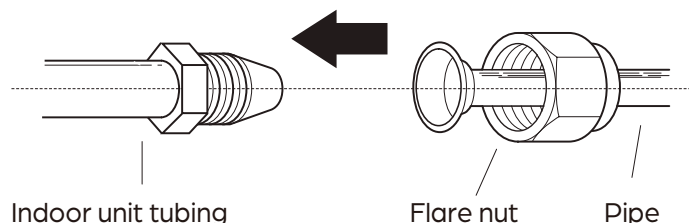

2. Tighten the flare nut as tightly as possible by hand.
3. Using a spanner, grip the nut on the unit tubing.
4. While firmly gripping the nut on the unit tubing, use a torque wrench to tighten the flare nut according to the torque values in the table below. Loosen the flaring nut slightly, then tighten again.

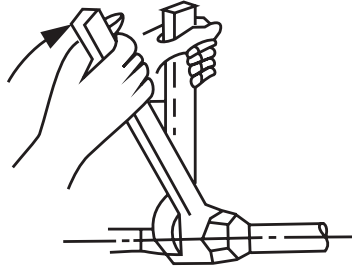

Outer Diameter of Pipe Inches (mm)	Tightening Torque lb-ft (Nm)	Flare Dimension "B" Inches (mm)	Flare Shape
Ø 3/8" (9.5mm)	23.6~28.8 (32~39)	0.52~0.53 (13.2~13.5)	
Ø 5/8" (15.9mm)	42~52.4 (57~71)	0.76~0.78 (19.2~19.7)	
Ø 3/4" (19.1mm)	49.4~74.5 (67~101)	0.91~0.93 (23.2~23.7)	



CAUTION

Do not use excessive torque. Excessive force can break the nut or damage the refrigerant piping. You must not exceed the torque requirements shown in the table above.

CONNECTING PIPING TO OUTDOOR UNIT

1. Remove the valve cover on the side of the outdoor unit.
2. Remove the protective caps from the ends of the valves.
3. Align flared pipe end with each valve and tighten the flare nut as tightly as possible by hand.
4. Using a spanner, grip the body of the valve. Do not grip the nut that seals the service valve.
5. While firmly gripping the body of the valve, use a torque wrench to tighten the flare nut according to the correct torque values in the table above.
6. Loosen the flare nut slightly, then tighten again.
7. Repeat steps 3-6 for the remaining pipe.

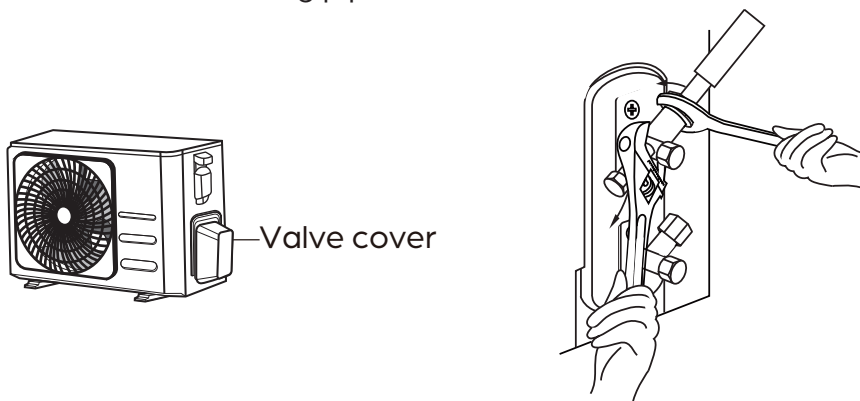

SYSTEM EVACUATION

PREPARATIONS AND PRECAUTIONS

Air and foreign matter in the refrigerant system can cause abnormal rises in pressure, which can damage the air handler, reduce energy efficiency, and cause injury. Use a vacuum pump and manifold gauge to evacuate the refrigerant system, removing any non-condensable gas and moisture from the system. Evacuation should be performed upon initial installation and if unit is relocated.

BEFORE PERFORMING EVACUATION

1. Check to make sure the refrigerant pipes connecting the indoor and outdoor units are connected properly and leak free.

EVACUATION INSTRUCTIONS

1. Connect the charge hose of the manifold gauge to service port on the outdoor unit's low pressure valve.
2. Connect another charge hose from the manifold gauge to the vacuum pump.
3. Open the Low Pressure side of the manifold gauge. Keep the High Pressure side closed.
4. Tighten refrigerant valve caps hand tight plus flat to ensure there are no vacuum leaks.
5. Turn on the vacuum pump to evacuate the system.
6. Run the vacuum for at least 15 minutes until the meter reads -76cmHg (-10 Pa) or 500 microns. (the time will depend on the vacuum pump used)
7. Close the low pressure side of the manifold gauge, and turn off the vacuum pump.
8. Wait for 5 minutes, then check that there has been no change in system pressure.
9. If there is a change in system pressure, check to make sure the brazed and flare fittings are sealed and refer to **Gas Leak Check** section. If there is no change in system pressure, you can proceed.
10. If each unit is shipped with 25ft (7.6m) of refrigerant. If more is necessary, add it through the low pressure service port on the unit.
11. After additional refrigerant is added if necessary, remove the charge hose from the service port and unscrew the cap from the high pressure valve on the unit.

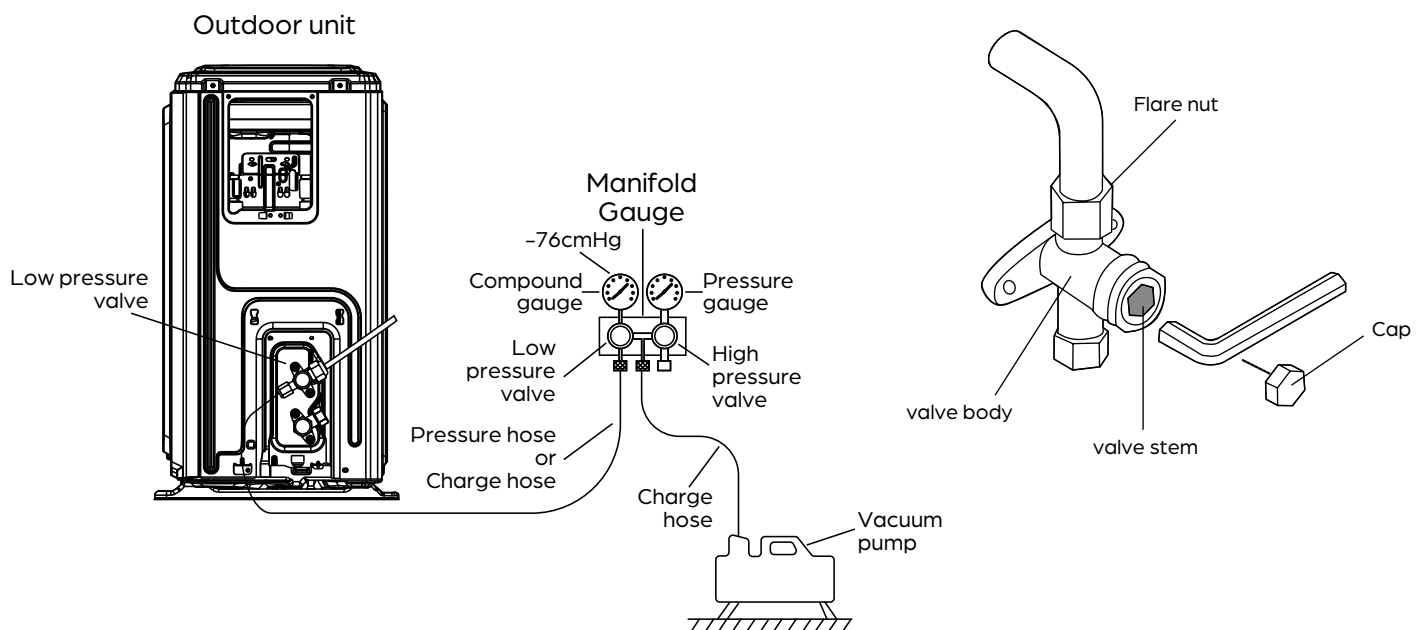

12. Insert hexagonal wrench into the high pressure valve and open the valve by turning the wrench in a 1/4 counterclockwise turn. Listen for gas to exit the system, then close the valve after 5 seconds. (Open the high pressure valve first. Do not try to force the valve to open further).
13. Watch the pressure gauge for one (1) minute to make sure that there is no change in pressure. The pressure gauge should read slightly higher than atmospheric pressure.
14. Using hexagonal wrench, fully open both the high pressure and low pressure valves.
15. Tighten all valve caps to ensure no leaks. You may tighten it further using a torque wrench if needed, being careful not to over tighten.

WIRING THE OUTDOOR UNIT

**WARNING**

Before performing any electrical or wiring work, turn off the main power to the system.

**WARNING**

Failure to follow warnings may lead to equipment damage, injury or death. Field line side wires may remain live, DO NOT perform service or maintenance until the main disconnect is pulled.

**WARNING**

While connecting the wires, strictly follow the wiring diagram, and refer to the nameplate for electrical information. Wire according to NEC and local codes.

The refrigerant circuit can become very hot. Keep the interconnection cable away from the copper tube.

Connect the Power Cable

The size of the power supply cable, fuse, and switch needed is determined by the minimum circuit ampacity (MCA) and maximum over current protection (MOCP) of system and the NEC and local codes in your area. Refer to the nameplate and power specification chart.

1. Remove the electrical wiring cover.
2. Remove the caps on the conduit panel.
3. Be sure to cut the wire several inches longer than the required length for future maintenance.
4. Feed the wires through the conduit mounting panel and temporarily mount the conduit tubes (sold separately).
5. Properly connect both the power supply to the corresponding terminals on the terminal block.
6. Ground the unit in accordance with local codes.

(See images on the next page.)



NOTE

The L1, L2 and ground positions may be different depending on the unit as shown below.

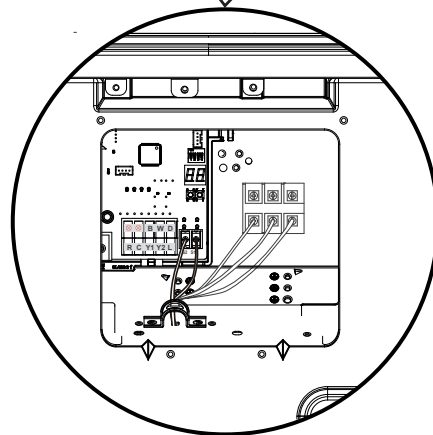
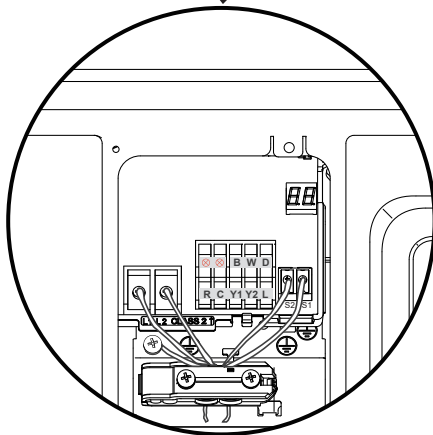
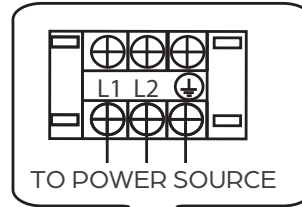
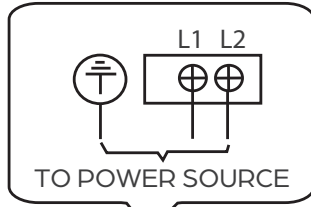

Connect the Signal Cable

The signal cable enables communication between the indoor and outdoor units. You must first choose the right cable size before preparing it for connection. Run a continuous length of cable and avoid splicing the cable.

Cable Sizing

Use the correct size cable depending on the communication type. See the indoor unit installation manual for more information.

- Non-polar RS485 Communication (S1/S2): 16 AWG to 20 AWG, 2 conductor wire can be used. On new installations or if you experience communication interference, it is strongly recommended to use 16 AWG stranded, shielded wire for the best communication.
- 24V Communication: 18 AWG thermostat wire



WARNING

Pay attention to the live wire. While crimping wires, make sure you clearly distinguish the Live ("L") Wire from other wires.



NOTE

The use of shielded communication or thermostat wire is not required, but is recommended where separation from high voltage conductors can not be maintained, or in areas with high electrical noise. The shield and drain conductor must be grounded only at the outdoor unit and stripped back and taped at the indoor unit. Grounding the wire at both ends results in an increase of noise transmitted onto the signal wires.



WARNING

All wiring work must be performed strictly in accordance with the wiring diagram. Isolate the power supply leads from the communication wire leads with the strain relief.

Connecting the signal cable

1. Using wire strippers, strip the rubber jacket from both ends of cable to reveal about 1.5" (38-40mm) of the wires inside.
2. Strip the insulation from the ends of the wires.
3. Using a wire crimper, crimp u-lugs on the ends of the wires.
4. Connect the low voltage wires according to desired connection method below. Refer to the wiring diagram and the indoor unit installation manual for more information.
5. Make sure any unused wires are properly insulated.
6. Permanently secure the conduit tubes to the conduit panel.
7. Replace the wire cover on the side of the unit, and screw it in place.

Connection Method 1 and 2: RS485 Communication

These are the preferred connection methods. They use S1/S2 (CN5) terminals for RS485 communication between the indoor unit and outdoor unit. The SW1-2 switch should remain off. **The following is an overview of the DRUM air handler wiring. Connection methods vary based on the indoor unit. Refer to the indoor unit installation manual for the most specific information.**

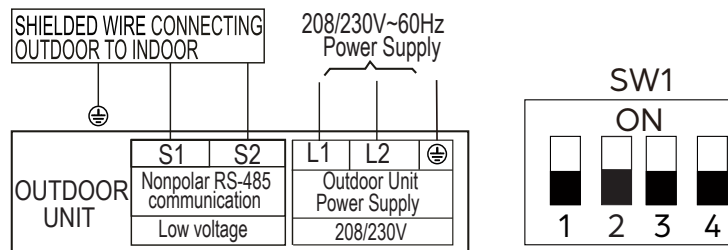

**Connection Method 1:
24V Thermostat**

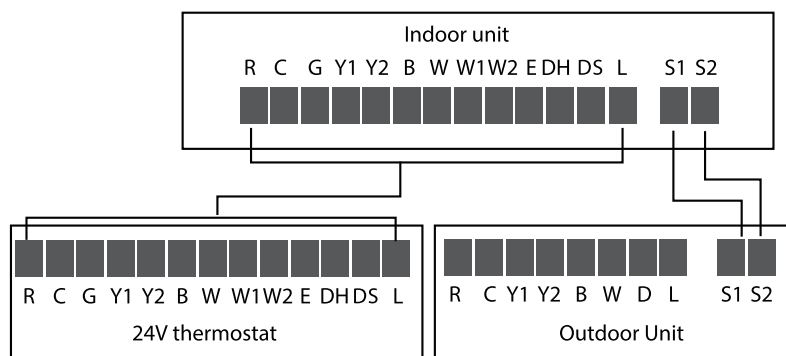

**Connection Method 2:
Included RS485 Thermostat**

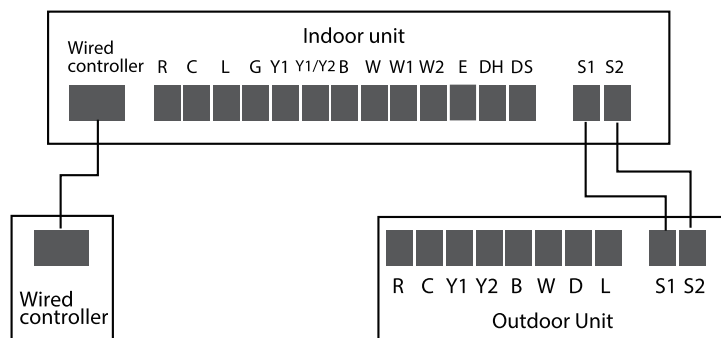

Connection Method 3: 24V Communication

This method does not comply with the DOE Controls Verification Procedure (10 CFR Part 429.134) effective 7/7/2026. AHRI rated systems must be installed using Method 1 or 2. This connection method is primarily used to pair with third party 24V units using 24V thermostat cable. Please note that depending on the thermostat used, the system may not operate to its full capability.



CAUTION

Do not connect 24V AC to S1 - S2, as this will damage the system.

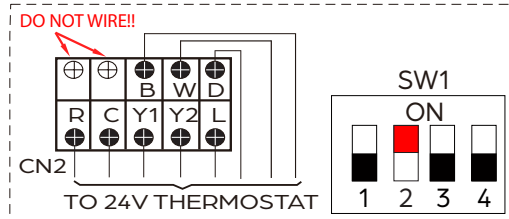

NOTE

The "B" terminal energizes the reversing valve on call for heat. Please ensure that thermostat configuration is set up for B functionality. Note: These methods are for use with a Durastar outdoor unit with 24V communication or with a third party air handler, cased coil, and gas furnace.

Wiring for 4H and 2C Thermostat

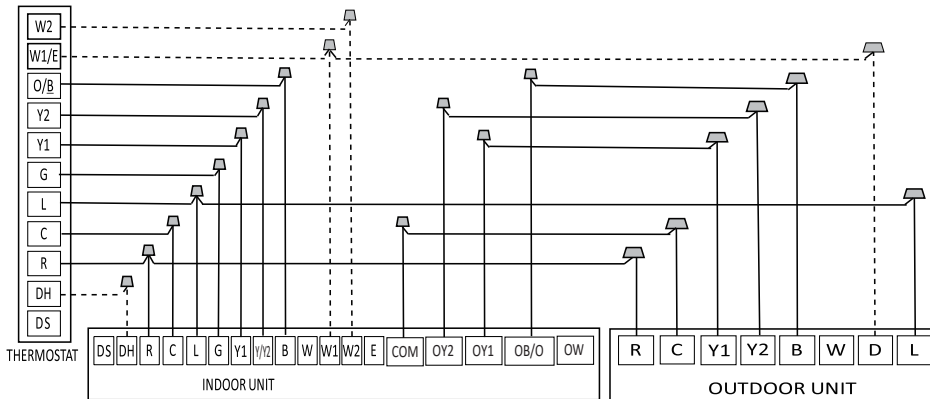

S4-2 Default on, DH function off.
Turn switch off to activate DH function.

S4-4 Default on, W1 and W2
shorted for single stage Aux heat operation. Turn off to separate stages.

Wiring for 3H and 2C Thermostat

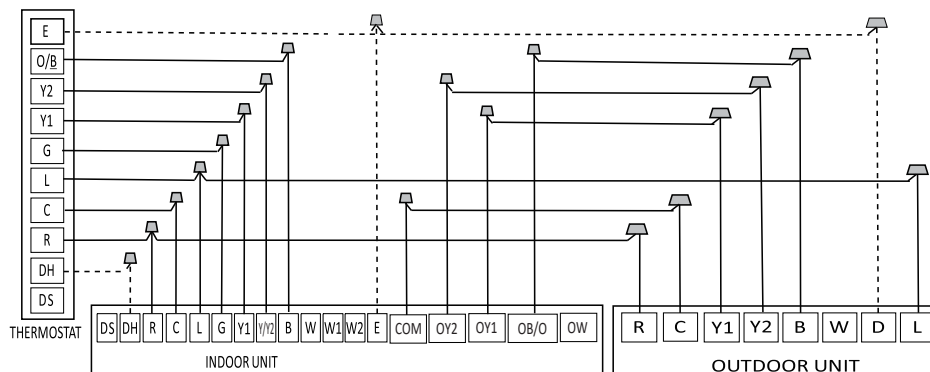

S4-2 Default on, DH function off.
Turn switch off to activate DH function.

Emergency heating controls two groups of electric heating strips at the same time.

Wiring for 3H and 2C Thermostat

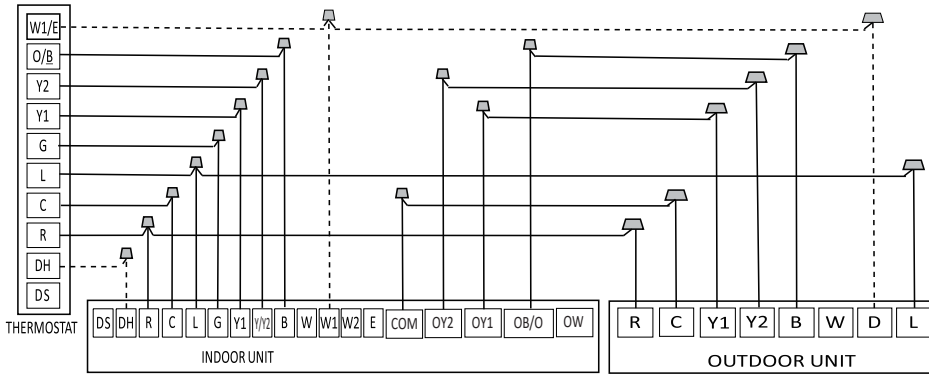

S4-2 Default on, DH function off. Turn switch off to activate DH function.

S4-4 Default on, W1 and W2 shorted for single stage Aux heat operation. Turn off to separate stages.

Wiring for 3H and 1C Thermostat

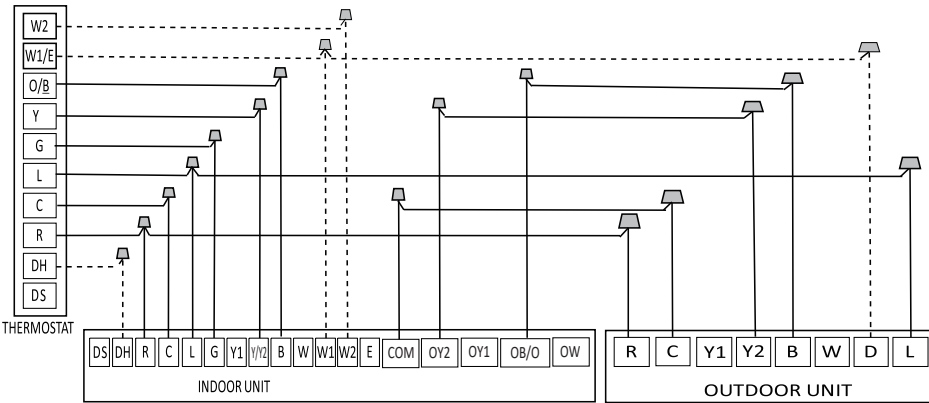

S4-2 Default on, DH function off. Turn switch off to activate DH function.

S4-4 Default on, W1 and W2 shorted for single stage Aux heat operation. Turn off to separate stages.

Wiring for 2H and 2C Thermostat

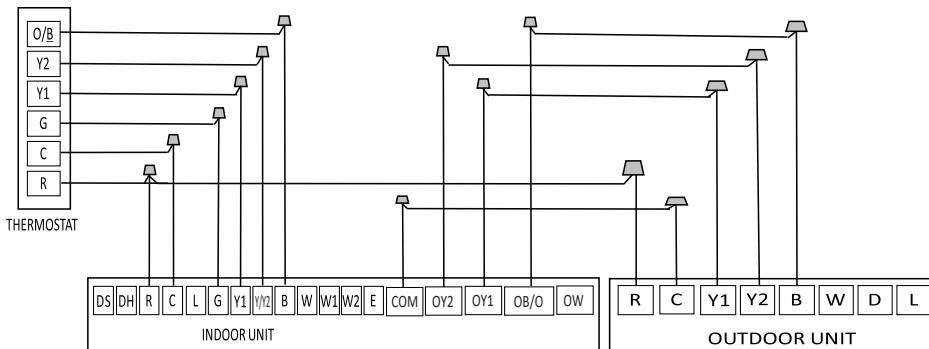

Wiring for 2H and 1C Thermostat

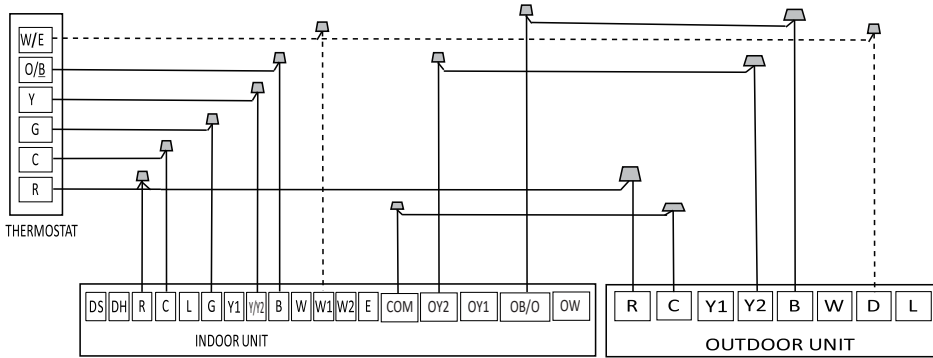

S4-4 Default on, W1 and W2 shorted for single stage Aux heat operation. Turn off to separate stages.

Wiring for 1H and 1C Thermostat (B Terminal)

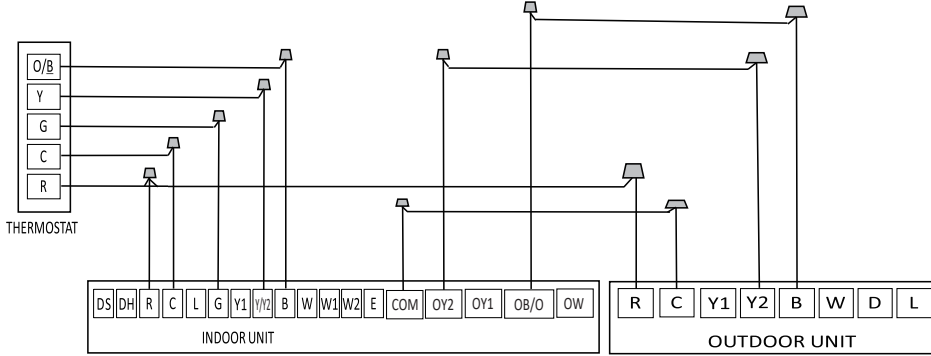

Wiring for 1H and 1C Thermostat (W Terminal)

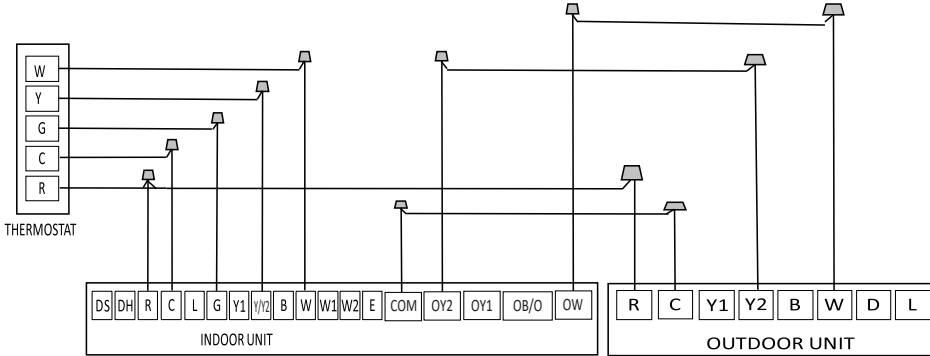

CONTROL LOGIC

Connector	Purpose
R	24v Power Connection
C	Common
Y1	Low Cooling
Y2	High Cooling
B	Heating Reversing Valve
W	Heating Control
D	Defrost Control
L	System Fault Signal

OUTDOOR UNIT SW1 DIP SWITCH SETTING

DIAL CODE	FEATURE	ON	OFF
SW1-1	N/A		
SW1-2	Communication type	24V communication between IDUonly	RS485 communication with DRSTAT101 or 24V tstat
SW1-3	Stronger cooling and heating function	Increases compressor frequency. Cooling will decrease around 5.5°F (3°C) in Y2 and 3.5°F (2°C) in Y1. Heating will increase around 5.5°F (3°C).	The cooling/ heating target pressure compensation value is invalid.
SW1-4	Enhanced defrosting	Enhanced defrosting with a more frequent defrost cycle	Default setting (standard defrost algorithm)



NOTE

Press the SW4 button for 10 seconds for forced defrosting.

FINAL CHECKS

BEFORE THE TEST RUN

Only perform the test run after you have completed the following steps:

- Electrical Safety Checks – Confirm that the unit's electrical system is connected and operating correctly.
- Gas Leak Check – Check all flare nut connections and confirm the system is not leaking.
- Confirm that the low and high pressure valves are fully open.
- Check grounding work by measuring the grounding resistance by visual detection and with a multimeter. The grounding resistance must be less than 0.1 Ω.

ELECTRICAL SAFETY CHECKS

After installation, confirm that all electrical wiring is installed in accordance with local and national regulations, and according to this installation manual.

DURING TEST RUN

Using your multimeter, verify the voltage of the main power entering the system. If the main power voltage is greater than ±10% of the name plate voltage, turn off the unit and immediately call a licensed electrician to find and resolve the cause.



WARNING

RISK OF ELECTRICAL SHOCK – All wiring must comply with local and national electrical codes, and must be installed by a licensed electrician.



TIP

Use the Durastar Job Site Information Sheet at the end of this manual as a commissioning report to record your start up readings.

GAS LEAK CHECK

There are two methods to check for gas leaks:

1. Soap and Water Method – Using a soft brush, apply a soapy water or liquid detergent to all pipe connection points on the indoor and outdoor unit. The presence of bubbles indicates a leak.
2. Leak Detector Method – If using a leak detector, refer to the device's operation manual for proper usage instructions.

GAS LEAK CHECK POINTS

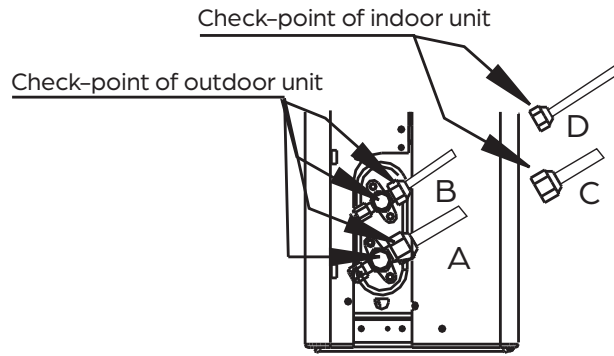

A: Low pressure stop valve
 B: High pressure stop valve
 C & D: Indoor unit flare nuts

TEST RUN

TEST RUN INSTRUCTIONS

You should perform the test run for at least 30 minutes.

1. Connect power to the unit.
2. Press the ON/OFF button on the remote controller or wired thermostat to turn the unit on.
3. Press the MODE button to scroll through the following functions, one at a time:
 - COOL – Select lowest possible temperature.
 - HEAT – Select highest possible temperature.
4. Let each function run for 5 minutes and perform the following checks:

LIST OF CHECKS TO PERFORM	[X]
Unit is Properly Grounded	[]
All Electrical Terminals are Properly Covered	[]
Indoor and Outdoor Units are Solidly Installed	[]
All Pipe Connection Points Do Not Leak	[]
Water Drains Properly from Drain Hose without leaks	[]
All Piping is Properly Insulated	[]
Unit Performs COOL Function Properly	[]
Unit Performs HEAT Function Properly	[]
There is no abnormal noise or vibration	[]
Indoor Unit Responds to Remote Controller or Thermostat	[]

5. Double check all pipe connections. During operation, the pressure of the refrigerant system will increase. This may reveal leaks that were not present during the initial leak check. Take time during the test run to recheck all pipe connection points. Refer to **Gas Leak Check** section for instructions.

TROUBLESHOOTING

SAFETY PRECAUTIONS

If ANY of the following conditions occurs, turn off your unit immediately!

- The power cord is damaged or abnormally warm
- You smell a burning odor
- The unit emits loud or abnormal sounds
- A power fuse blows or the circuit breaker frequently trips
- Water or other objects fall into or out of the unit

DO NOT ATTEMPT TO FIX THESE YOURSELF! CONTACT AN AUTHORIZED SERVICE PROVIDER IMMEDIATELY!

COMMON ISSUES

The following problems are not a malfunction and in most situations will not require repairs.

ISSUE	POSSIBLE CAUSES
Unit does not turn on when pressing ON/OFF button	The unit has a 3-minute protection feature that prevents the unit from overloading. The unit cannot be restarted within three minutes of being turned off.
The unit changes from COOL/HEAT mode to FAN mode	The unit may change its setting to prevent frost from forming on the unit. Once the temperature increases, the unit will start operating in the previously selected mode again.
	The set temperature has been reached, at which point the unit turns off the compressor. The unit will continue operating when the temperature fluctuates again.
The indoor unit emits white mist	In humid regions, a large temperature difference between the room's air and the conditioned air can cause white mist.
Both the indoor and outdoor units emit white mist	When the unit restarts in HEAT mode after defrosting, white mist may be emitted due to moisture generated during the defrosting process.
The indoor unit makes noises	A rushing air sound may occur when the louver resets its position.
	A squeaking sound may occur after running the unit in HEAT mode due to expansion and contraction of the unit's plastic parts.
Both the indoor unit and outdoor unit make noises	Low hissing sound during operation: This is normal and is caused by refrigerant gas flowing through both indoor and outdoor units.
	Low hissing sound when the system starts, has just stopped running, or is defrosting: This noise is normal and is caused by the refrigerant gas stopping or changing direction.
	Squeaking sound: Normal expansion and contraction of plastic and metal parts caused by temperature changes during operation can cause squeaking noises.

ISSUE	POSSIBLE CAUSES
The outdoor unit makes noises	The unit will make different sounds based on its current operating mode.
Dust is emitted from either the indoor or outdoor unit	The unit may accumulate dust during extended periods of non-use, which will be emitted when the unit is turned on. This can be mitigated by covering the unit during long periods of inactivity.
The unit emits a bad odor	The unit may absorb odors from the environment (such as furniture, cooking, cigarettes, etc.) which will be emitted during operations.
	The unit's filters have become moldy and should be cleaned.
The fan of the outdoor unit does not operate	During operation, the fan speed is controlled to optimize product operation.
Operation is erratic, unpredictable, or unit is unresponsive	Interference from cell phone towers and remote boosters may cause the unit to malfunction. In this case, try the following: <ul style="list-style-type: none"> • Disconnect the power, then reconnect. • Press ON/OFF button on remote control to restart operation.



NOTE

If your problem persists after performing the checks and diagnostics above, turn off your unit immediately and contact an authorized service center.

LED DISPLAY

The control displays unit status as well as any active fault codes on the LED display. If the unit is functioning normally, the LED will display current temperature set point. When a fault code is active, the display will flash quickly the active fault code. Please refer to the error code table on the following page.

ERROR AND OPERATING CODES

Error Code	Description
dF	Defrost (not an error)
FC	Forced Cooling (not an error)
EC07	ODU fan speed out of control
EC51	ODU EEPROM parameter error
EC52	ODU coil temp. sensor (T3) error
EC53	ODU ambient temp. sensor (T4) error
EC54	COMP. discharge temp. sensor (TP) error
EC55	ODU IPM module temperature sensor malfunction
EC57	Refrigerant pipe temperature sensor error
EC5C	Pressure sensor failure
EL01	IDU & ODU communication error
EL16	Communication malfunction between adapter board and ODU main board
LC06	High temperature protection of Inverter module (IPM)
PC00	ODU IPM module protection
PC02	Compressor top (or IPM) temp. protection/ Refrigerant sensor error
PC06	Discharge temperature protection of compressor
PC08	ODU over-current protection
PC0A	High temperature protection of condenser
PC0F	PFC module protection
PC10	ODU low AC voltage protection
PC11	ODU main control board DC bus high voltage protection
PC12	ODU main control board DC bus low voltage protection/341 MCE error
PC30	System high pressure protection
PC31	System low pressure protection
PC40	Communication error between ODU main chip and compressor driven chip
PC41	Compressor current sampling failure
PC42	Compressor start failure of ODU
PC43	ODU compressor lack phase protection
PC44	ODU zero speed protection
PC45	ODU IR chip drive failure
PC46	Compressor speed has been out of control
PC49	Compressor over-current failure
PH90	High temperature protection of evaporator
PH91	Low temperature protection of evaporator

WIRING DIAGRAMS

DRU1U18S2A

WIRING DIAGRAM
16022000040910

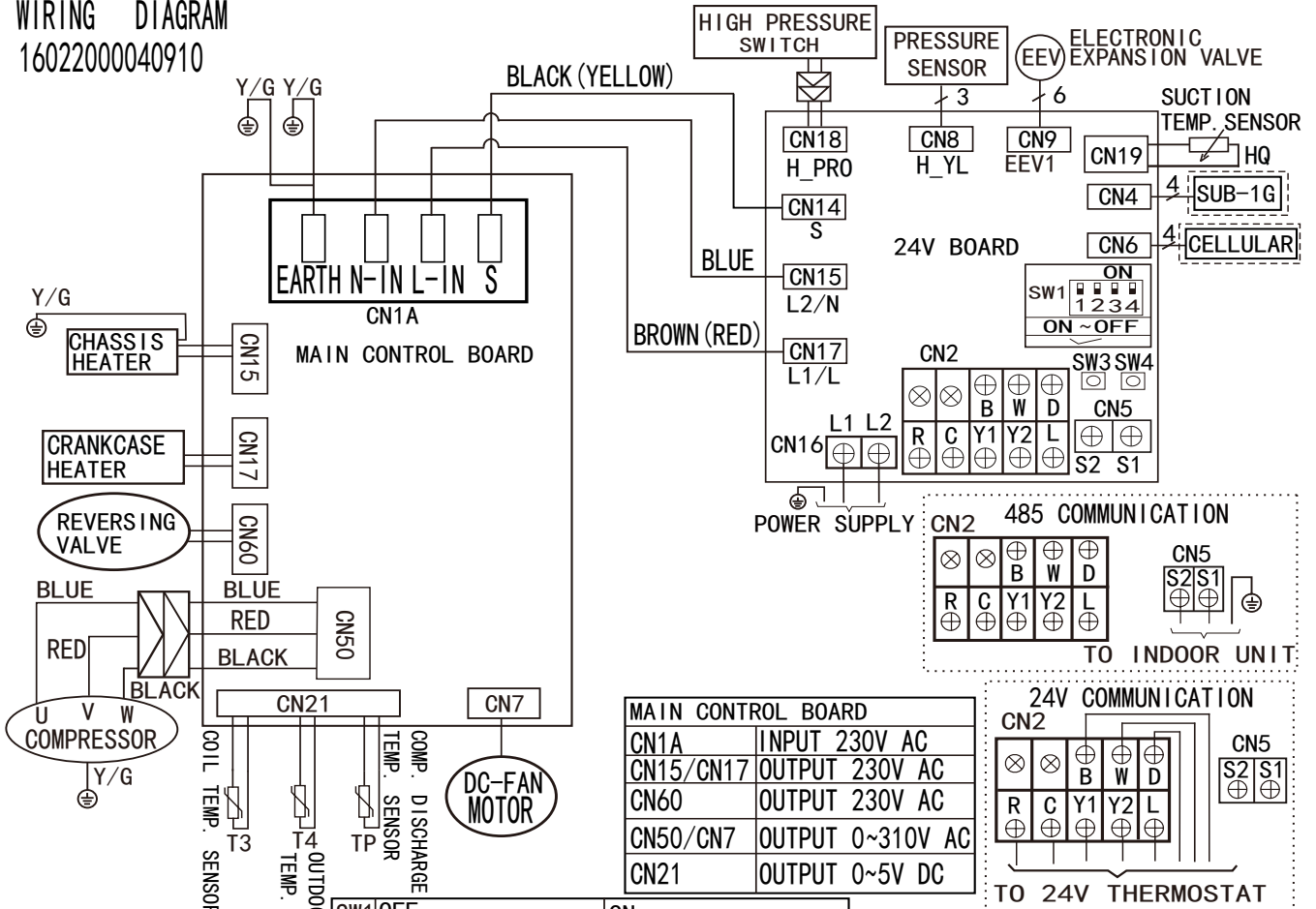

MAIN CONTROL BOARD	
CN1A	INPUT 230V AC
CN15/CN17	OUTPUT 230V AC
CN60	OUTPUT 230V AC
CN50/CN7	OUTPUT 0~310V AC
CN21	OUTPUT 0~5V DC

SW1	OFF	ON
1	NONE	NONE
2	24V COMMUNICATION/ 485 COMMUNICATION	24V COMMUNICATION ONLY
3	NONE	STRONGER CAPACITY OUTPUT (ONLY 24V COMMUNICATION)
4	DEFAULT SETTING	ENHANCED DEFROSTING

24V BOARD	
CN16	INPUT 230V AC
CN2	INPUT 0~24V AC
CN17/CN15/CN14	OUTPUT 230V AC
CN18/CN19/CN5	OUTPUT 0~5V DC
CN4/CN6/CN8	OUTPUT 0~5V DC
CN9	OUTPUT 0~12V DC

Notes:
This symbol indicates the element is optional, the actual shape shall prevail.

DRU1U24S2A, DRU1H18S2A & DRU1H24S2A

WIRING DIAGRAM 16022000040710

Notes:

This symbol indicates the element is optional, the actual shape shall prevail.

Y/G

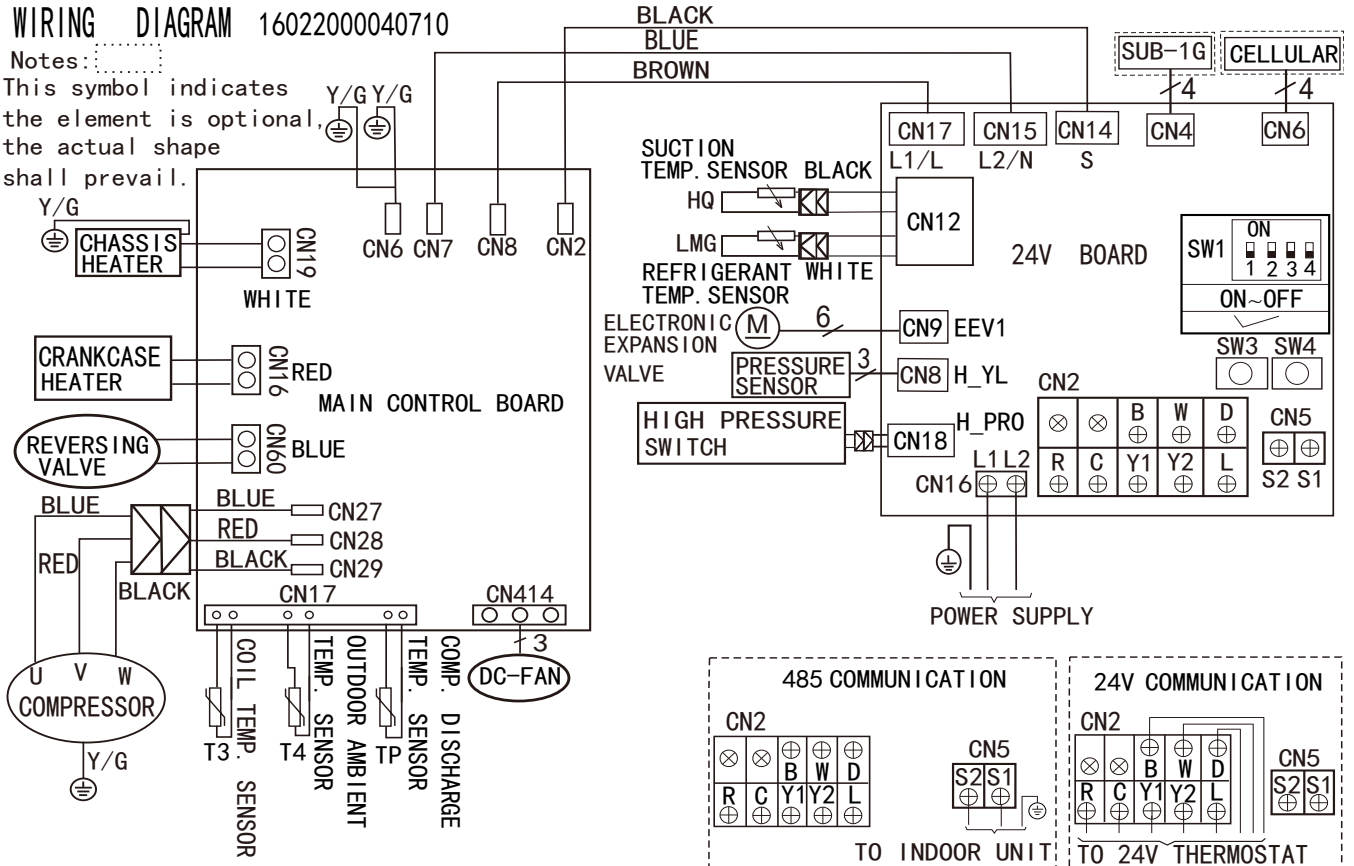

MAIN CONTROL BOARD		24V BOARD	
CN2/CN7/CN8	INPUT 230V AC	CN16	INPUT 230V AC
CN16	OUTPUT 230V AC	CN18/CN12/CN5	OUTPUT 0~5V DC
CN60	OUTPUT 230V AC	CN4/CN6/CN8	OUTPUT 0~5V DC
CN19	OUTPUT 230V AC	CN9	OUTPUT 0~12V DC
CN17	OUTPUT 0~5V DC	CN14/CN15/ CN17	OUTPUT 230VAC
CN414	OUTPUT 0~310V AC	CN2	INPUT 0~24VAC
CN27/CN28/CN29	OUTPUT 0~310V AC		

SW1	OFF	ON
1	NONE	NONE
2	24V COMMUNICATION /485 COMMUNICATION	24V COMMUNICATION ONLY
3	NONE	STRONGER CAPACITY OUTPUT (ONLY 24V COMMUNICATION)
4	DEFAULT SETTING	ENHANCED DEFROSTING

DRU1U30S2A

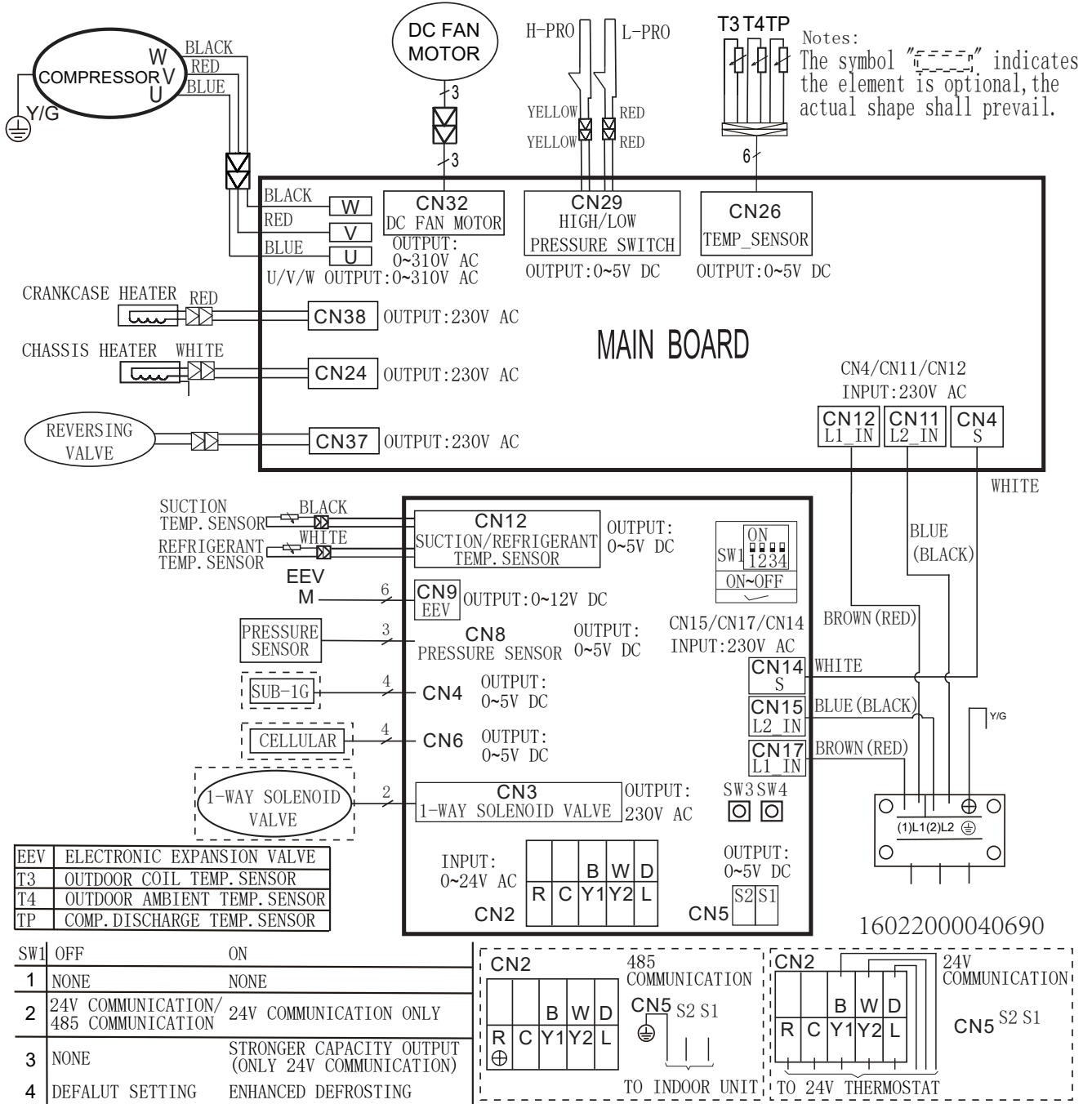

DRU1H30S2A & DRU1U36S2A

Notes: 1. 36K regular heat model does not have the COMP. TOP OLP TEMP. SENSOR.
 2. The symbol "-----" indicates the element is optional, the actual shape shall prevail.

16022000041438

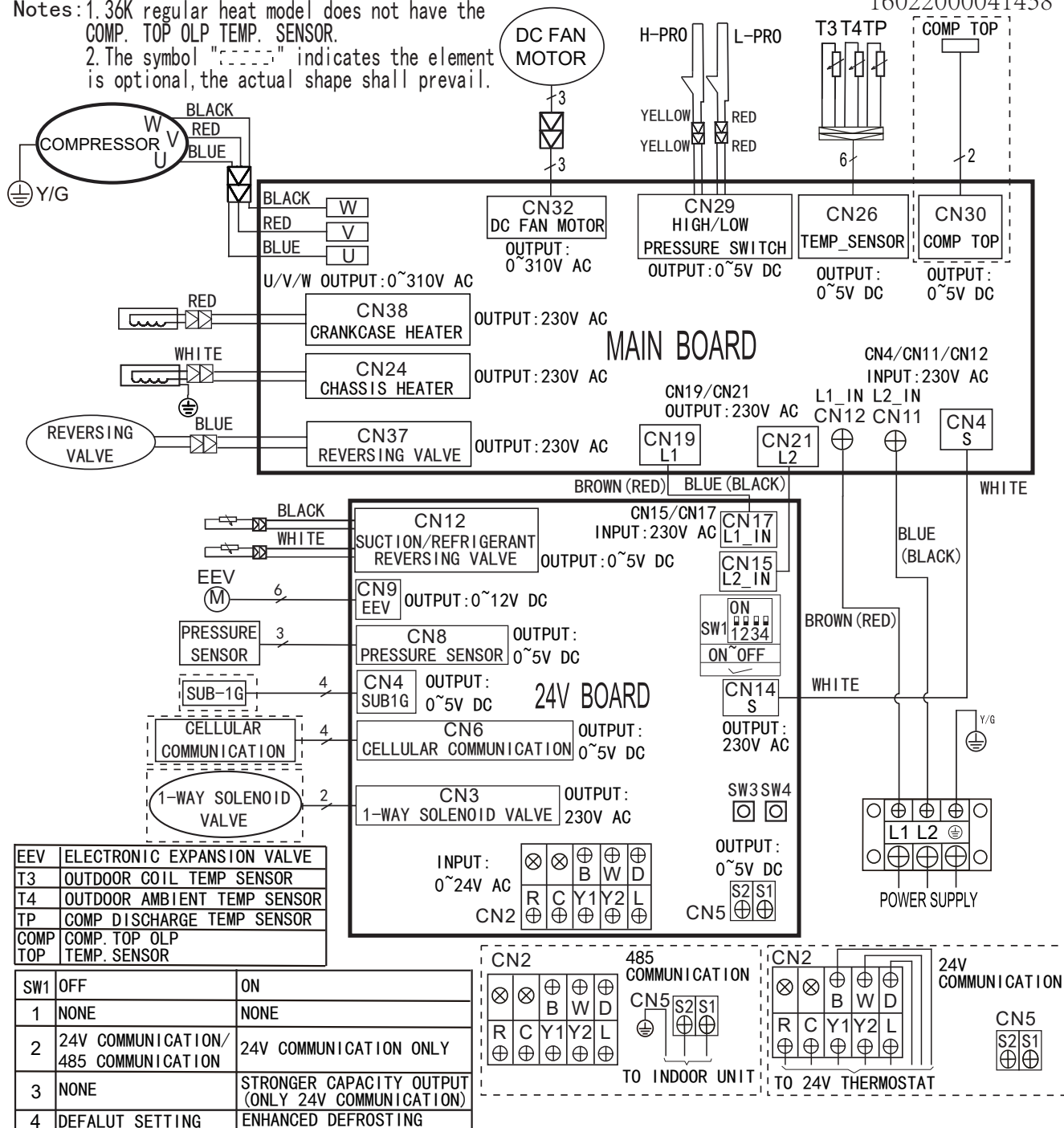

DRU1H36S2A, DRU1H42S2A, DRU1U48S2A, DRU1H48S2A & DRU1U60S2A

Notes:

1. COMP. TOP OLP TEMP. SENSOR and EEV2 are only for 36K hyper heat model.
2. The symbol "-----" indicates the element is optional, the actual shape shall prevail.

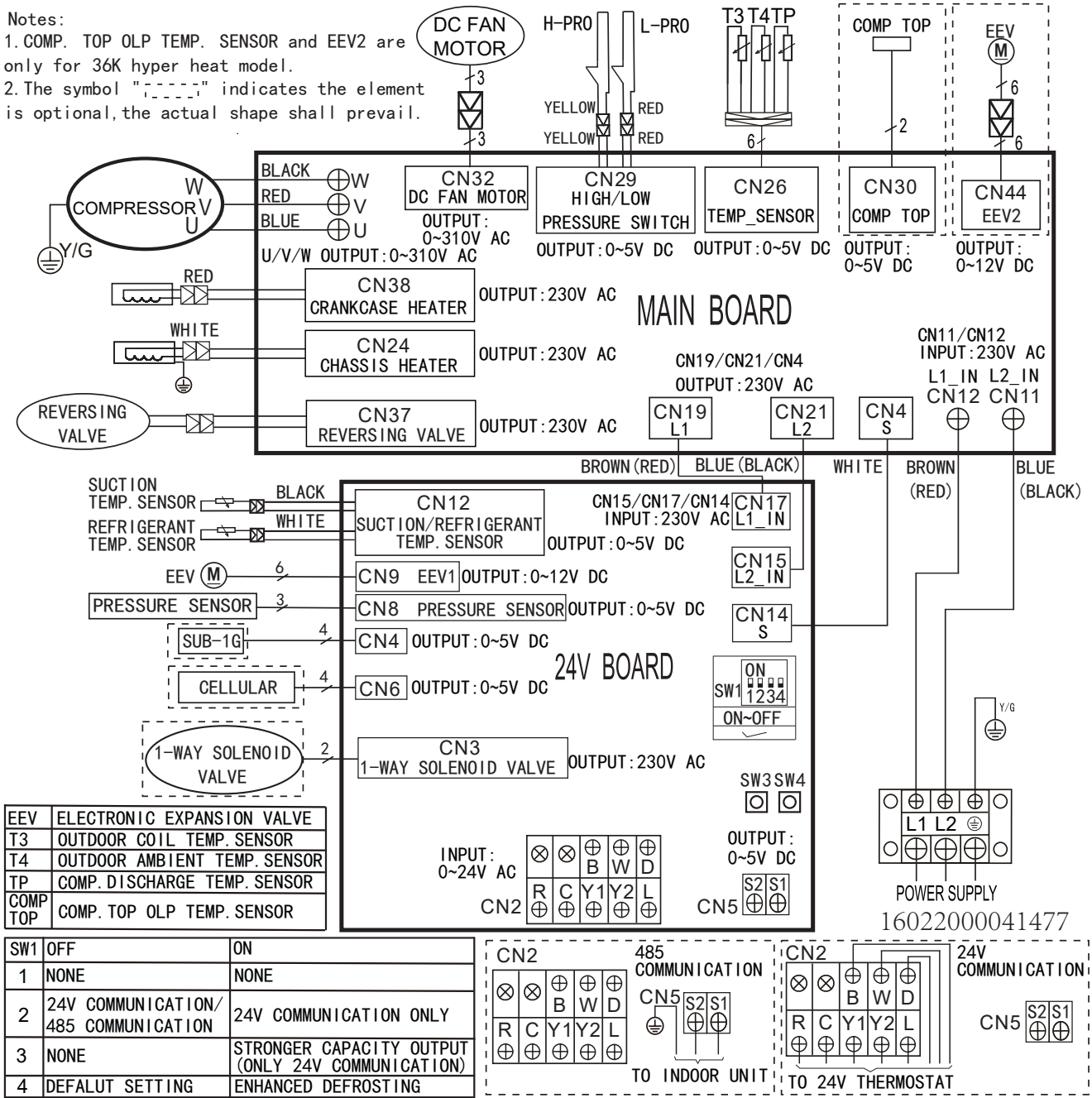

DRU1H49S2A & DRU1H60S2A

WIRING DIAGRAM(OUTDOOR UNIT)
16022000041440

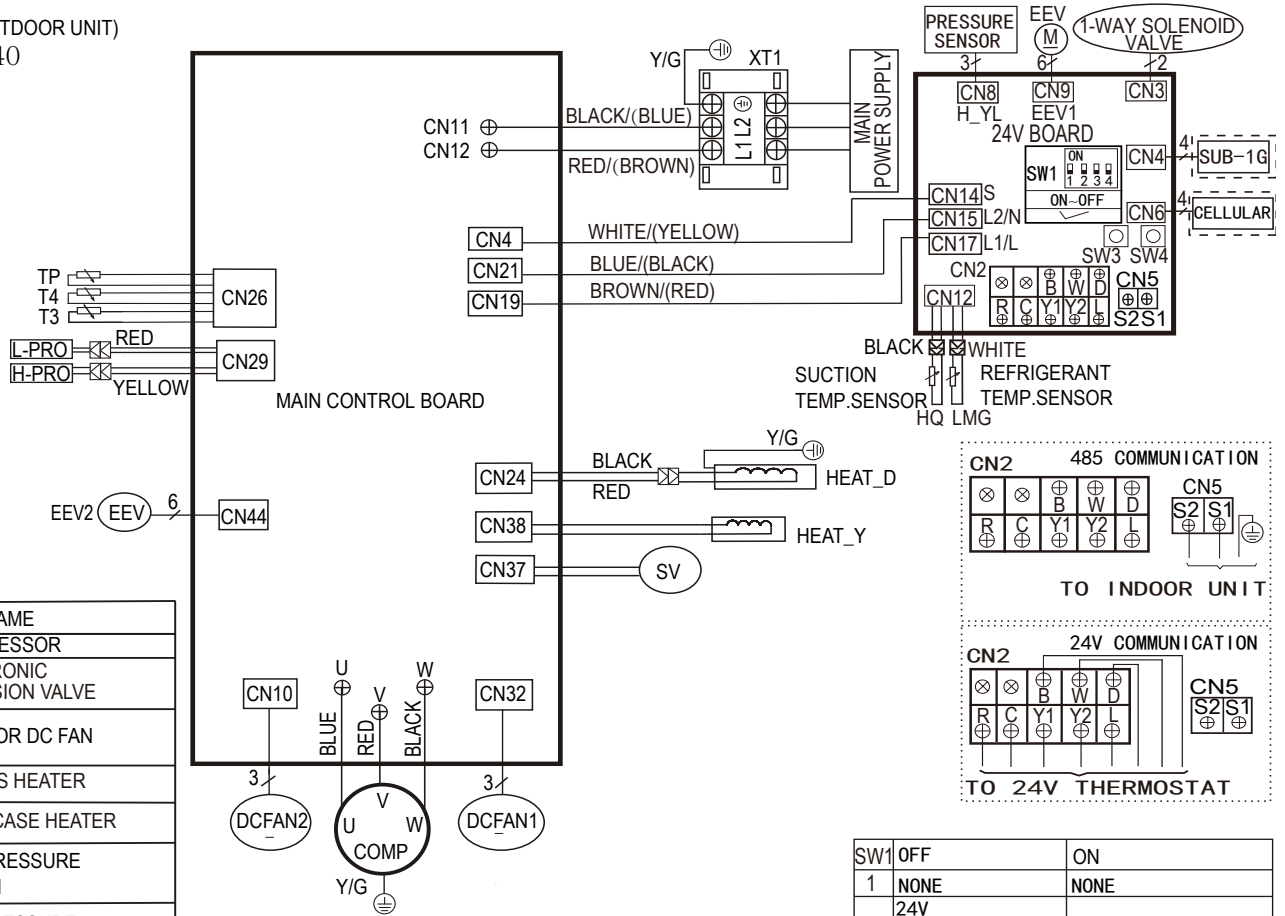

CODE	PART NAME
COMP	COMPRESSOR
EEV	ELECTRONIC EXPANSION VALVE
DCFAN1 DCFAN2	OUTDOOR DC FAN
HEAT_D HEAT_Y	CHASSIS HEATER CRANKCASE HEATER
H-PRO	HIGH PRESSURE SWITCH
L-PRO	LOW PRESSURE SWITCH
SV	REVERSING VALVE
TP	COMP. DISCHARGE TEMP. SENSOR
T3	OUTDOOR COIL TEMP. SENSOR
T4	OUTDOOR AMBIENT TEMP. SENSOR

MAIN CONTROL BOARD	
CN11/CN12	INPUT 230V AC
CN19/CN21	OUTPUT 230V AC
CN4	INPUT 230V AC
CN38/CN24/ CN37	OUTPUT 230V AC
CN44	OUTPUT 0-12V DC
CN26/CN29	OUTPUT 0-5V DC
CN32/CN10 /U/V/W	OUTPUT 0-310V AC

24V BOARD	
CN17/CN15	INPUT 230V AC
CN12/CN8/CN5	OUTPUT 0-5V DC
CN4/CN6	OUTPUT 0-5V DC
CN9	OUTPUT 0-12V DC
CN3	OUTPUT 230V AC
CN14	OUTPUT 230V AC
CN2	INPUT 0-24V AC

SW1	OFF	ON
1	NONE	NONE
2	24V COMMUNICATION/ 485 COMMUNICATION	24V COMMUNICATION ONLY
3	NONE	STRONGER CAPACITY OUTPUT (ONLY 24V COMMUNICATION)
4	DEFAULT SETTING	ENHANCED DEFROSTING

Notes: This symbol indicates the element is optional, the actual shape shall prevail.

JOB SITE INFORMATION SHEET

Site Information

Job Name: _____ Installation Date: _____

Address: _____ City: _____ State: _____ Zip: _____

Phone: _____ Email: _____

Contractor Information

Contractor Name: _____ Technician Name: _____

Address: _____ City: _____ State: _____ Zip: _____

Phone: _____ Email: _____

Outdoor Unit (ODU) Information

ODU Model #: _____ ODU Serial #: _____

Unit Location: _____

Indoor Unit (IDU) Information

IDU Model #: _____ IDU Serial #: _____

Unit Type: _____ Unit Location: _____

Refrigerant Line Size (Circle Liquid and Gas Line): 1/4" 3/8" 1/2" 5/8"

Line Set Length: _____

Outdoor Electrical Readings

Line Power Wire Color: L1 _____ L2 _____ G _____

Line Voltage (Power Off): L1 to L2 _____ L1 to G _____ L2 to G _____

Line Voltage (Power On): L1 to L2 _____ L1 to G _____ L2 to G _____

Outdoor to Indoor Electrical Readings

IDU Power/Control Wire Color: 1 _____ 2 _____ 3 _____

Voltage Readings: 1-2 _____ AC 2-3 _____ DC

Outdoor Thermal Readings

ODU Discharge: _____ °F OD Ambient: _____ °F

Gas Line Saturation: _____ °F Liquid Line Saturation: _____ °F

Indoor Electrical Readings

IDU Power/Control Wire Color: 1 _____ 2 _____ 3 _____

Voltage Readings: 1-2 _____ AC 2-3 _____ DC

Indoor Thermal Readings

Return Air: _____ °F Supply Air: _____ °F Room Air: _____ °F

THIS PAGE INTENTIONALLY LEFT BLANK.