

INSTALLATION MANUAL

MULTI-POSTIONAL AIR HANDLER: 18K – 60K BTU

DRUM1824S2A, DRUM3036S2A, DRUM4260S2A

R-454B, 115/208/230V, 1ph 60HZ, 24V / RS485 Communicating

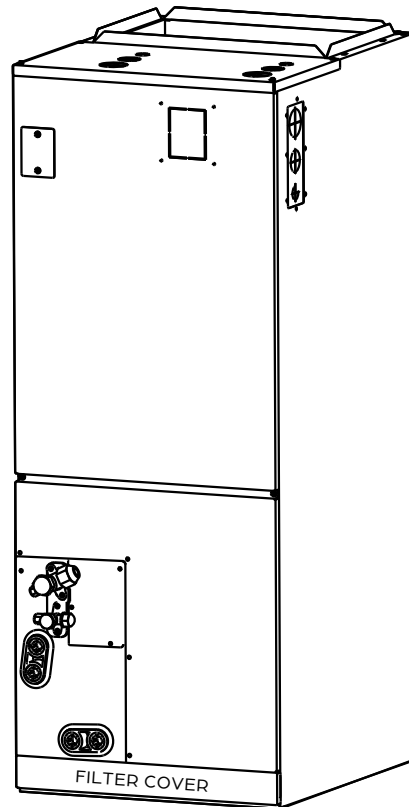

Model Number:

Serial Number:

Purchase Date:

Installing Contractor Company Name:



NOTE

This manual only refers to the models listed above. If you are installing the DRAM18F2A or DRAM24F2A please refer to the manual included with that unit.



TIP

Capture relevant information about your Durastar mini-split equipment before it is installed and write it above for future reference.

TABLE OF CONTENTS

INTRODUCTION	3
SYMBOLS USED IN THIS MANUAL.....	3
IMPORTANT SAFETY PRECAUTIONS	4
COMPATIBILITY AND SPECIFICATION OVERVIEW.....	16
OPERATING TEMPERATURES.....	16
ACCESSORIES.....	17
UNIT DIMENSIONS	18
FILTER SIZE	19
PARTS IDENTIFICATION	19
INSTALLATION PREPARATION.....	20
AIR HANDLER INSTALLATION	28
DUCT REQUIREMENTS	29
CONDENSATE PIPING INSTALLATION.....	30
REFRIGERANT PIPING CONNECTION.....	32
WIRING OVERVIEW.....	38
ELECTRIC HEATER INSTALLATION (OPTIONAL).....	38
INDOOR UNIT WIRING	39
115V POWER SUPPLY CONVERSION GUIDE.....	40
CONTROL LOGIC	46
AIR HANDLER POWER SPECIFICATIONS	46
LED DISPLAY DEFINITIONS	47
DIP SWITCH SETTINGS	48
DIP SWITCH DEFINITIONS.....	50
AIR VOLUME TABLE	52
OPTIONAL FUNCTION WIRING	54
FINAL CHECKS.....	56
TEST RUN	57
TROUBLESHOOTING.....	58
WIRING DIAGRAMS.....	61
ERROR AND OPERATING CODES.....	63

INTRODUCTION

To better serve you, please do the following before contacting customer service:

- If you received a damaged product, immediately contact the retailer or dealer that sold you the product.
- Read and follow this manual carefully to help you use and maintain your air handler.
- Read the troubleshooting section of this manual as it will help you diagnose and solve common issues.
- Visit us on the web at www.durastar.com to download product guides and up-to-date information.
- If you need warranty service, our friendly customer service representatives are available via email at questions@durastar.com or by telephone at 1-888-320-0706.

SYMBOLS USED IN THIS MANUAL



WARNING: The warning symbol indicates personal injury or loss of life is possible. Extra care and precautions should be taken to ensure the user's safety.



CAUTION: The caution symbol indicates property damage or other serious consequences could occur.



NOTE: The pencil indicates any manufacturer notes relating to surrounding content. These may include further clarifications or call-outs.



TIP: A light bulb symbol indicates suggested manufacturer tips for the user to get the most out of the Durastar equipment and to accommodate the best user experience.



Refrigerant
Safety Group
A2L

WARNING:

RISK OF FIRE DUE TO FLAMMABLE MATERIALS
Follow handling instructions carefully in compliance with national regulations.

Explanation of symbols displayed on the unit

	CAUTION	This symbol shows that the operation manual should be read carefully.
	CAUTION	This symbol shows that a service personnel should be handling this equipment with reference to the installation manual.
	CAUTION	This symbol shows that information is available such as the operating manual or installation manual.

**WARNING**

Turn off the air conditioner and disconnect the power before installing, cleaning, or repairing the air conditioner. Failure to do so can cause electric shock.

IMPORTANT SAFETY PRECAUTIONS

Improper handling can cause serious damage or injury. Please read the following safety information in its entirety.



Operation, Cleaning, and Maintenance Safety Precautions

- Children and people with reduced physical, sensory, or mental capabilities, or lack of experience and knowledge, should only use, clean, or maintain this air conditioner if they are given supervision or instructions concerning use of the air conditioner in a safe way and understand the hazards involved. Children should not play with the air conditioner.
- Maintenance or repair must be performed by qualified professionals. Otherwise, you may experience personal injury or damage to the air conditioner and surrounding property.
- Disconnect the power supply by turning it off at the circuit breaker when cleaning, maintaining, or repairing the air conditioner. Otherwise, you could risk electric shock.
- When turning the unit on or off via the emergency operation switch, press the switch with an insulated object other than metal.
- If the below problems occur, please turn off the air conditioner and disconnect power at the circuit breaker immediately. Then contact your dealer or a qualified professional for service.
 - The power cord is overheating or damaged.
 - There is an abnormal sound during operation.
 - The circuit breaker trips frequently.
 - The air conditioner gives off a burning smell.
 - The indoor unit is leaking.
- Do not block the air outlet or air inlet. This could cause a malfunction.
- Never stick fingers or any other body parts into the air conditioner openings. The internal fan may be rotating at high speeds, and may result in injury.
- Do not spill water on the remote control as this can permanently damage the remote.
- Do not spray water on the indoor unit. This could cause electric shock or a unit malfunction.
- Do not clean the air conditioner with excessive amounts of water.
- Do not clean the air conditioner with combustible cleaning agents; they can cause fire or deformation.
- After removing the filter, do not touch the fins in order to avoid injury.
- Do not use fire or a hair dryer to dry the filter. This could cause a deformation or fire hazard.
- Do not step on the top panel of the unit, or put heavy objects on the top panel. This could cause damage or personal injury.
- Do not use flammable materials such as hair spray, lacquer, or paint near the air conditioner as they may catch fire.
- Do not operate the air conditioner in places near combustible gases. Emitted gases may collect around the air conditioner and cause an explosion.
- Do not operate your air conditioner in a wet room such as a bathroom or laundry room. Too much exposure to water can cause electrical components to short circuit.
- If the air conditioner is used together with burners or other heating devices, thoroughly ventilate the room to avoid oxygen deficiency.



Electrical Safety

- Do not modify the length of the power supply cord or use an extension cord to power the unit.
- If the supply cord is damaged, it must be replaced by the manufacturer, a service agent, or a similarly qualified person in order to avoid a safety hazard.
- Keep power plug clean. Remove any dust or grime that accumulates on or around the plug. Dirty plugs can cause fire or electric shock.
- Do not pull power cord to unplug unit. Hold the plug firmly and pull it from the outlet. Pulling directly on the cord can damage it, which can lead to fire or electric shock.
- Do not share the electrical outlet with other appliances. Improper or insufficient power supply can cause fire or electrical shock.
- The product must be properly grounded at the time of installation, or electrical shock may occur.
- For all electrical work, follow all local and national wiring standards and regulations. Connect cables tightly, and clamp them securely to prevent external forces from damaging the terminal. Improper electrical connections can overheat and cause fire, and may also cause shock. All electrical connections must be made according to the Electrical Connection Diagram located on the panels of the indoor and outdoor units.
- All wiring must be properly arranged to ensure that the control board cover can close properly. If the control board cover is not closed properly, it can lead to corrosion and cause the connection points on the terminal to heat up, catch fire, or cause electrical shock.
- If connecting power to fixed wiring, an all-pole disconnection device which has at least 3mm clearances in all poles, and have a leakage current that may exceed 10mA, the residual current device(RCD) having a rated residual operating current not exceeding 30mA, and disconnection must be incorporated in the fixed wiring in accordance with the wiring rules.
- The air conditioner's circuit board (PCB) is designed with a fuse to provide over-current protection. The specifications of the fuse are printed on the circuit board.



Installation Safety

- Installation must be performed by an authorized dealer or specialist. Improper installation can cause water leakage, electrical shock, or fire. (In North America, installation must be performed in accordance with NEC and CEC requirements by authorized personnel only.)
- Installation must be performed according to the installation instructions. Improper installation can cause water leakage, electrical shock, or fire.
- This air conditioner shall be installed in accordance with national and local wiring regulations.
- Contact an authorized service technician for repair or maintenance of this unit.
- Only use the included accessories, parts, and specified parts for installation. Using non-standard parts can cause water leakage, electrical shock, fire, and can cause the unit to fail.
- Install the unit in a firm location that can support the unit's weight. If the chosen location cannot support the unit's weight, or the installation is not done properly, the unit may fall and cause serious injury and damage.
- Install drainage piping according to the instructions in the installation manual. Improper drainage may cause water damage to your home and property.
- For units that have an auxiliary electric heater, do not install the unit within 3 feet (1 meter) of any combustible materials.
- Do not install the unit in a location that may be exposed to combustible gas leaks. If combustible gas accumulates around the unit, it may cause a fire.

- Do not turn on the power until all work has been completed.
- When moving or relocating the air conditioner, consult experienced service technicians for disconnection and re-installation of the unit.
- Be careful when opening or closing valves below freezing temperatures. Refrigerant may spurt out from the gap between the valve stem and the valve body, resulting in injuries.

**WARNING: REFRIGERANT SAFETY (A2L)**

- Do not use means to accelerate the defrosting process or to clean the unit, other than those recommended by the manufacturer.
- The appliance shall be stored in a room without continuously operating ignition sources (for example: open flames, an operating gas appliance or an operating electric heater).
- Do not pierce or burn.
- Be aware that flammable refrigerants may not contain an odor.
- Compliance with national refrigerant regulations shall be observed.

**A2L REFRIGERANT SAFETY PRECAUTIONS****1. Installation (Where Refrigerant Pipes Are Allowed)**

- Any person who is involved with working on or breaking into a refrigerant circuit should hold a current valid certificate from an industry-accredited assessment authority, which authorizes their competence to handle refrigerants safely in accordance with an industry recognized assessment specification.
- Maintenance and repair requiring the assistance of other skilled personnel shall be carried out under the supervision of the person competent in the use of flammable refrigerants.
- That the installation of pipe-work shall be kept to a minimum.
- That pipe-work shall be protected from physical damage.
- Where refrigerant pipes shall be compliance with national gas regulations.
- That mechanical connections shall be accessible for maintenance purposes.
- Be more careful that foreign matter(oil, water,etc) does not enter the piping. Also, when storing the piping, securely seal the opening by pinching, taping, etc.
- All working procedure that affects safety means shall only be carried by competent persons.
- Appliance shall be stored in a well ventilated area where the room size corresponds to the room area as specific for operation.
- Joints shall be tested with detection equipment with a capability of 0.18 oz (5 g) per year of refrigerant or better, with the equipment in standstill and under operation or under a pressure of at least these standstill or operation conditions after installation. Detachable joints shall NOT be used in the indoor side of the unit (brazed, welded joint could be used).
- In cases that require mechanical ventilation, ventilation openings shall be kept clear of obstruction.

LEAK DETECTION SYSTEM installed. Unit must be powered except for service. For the unit with refrigerant sensor, when the refrigerant sensor detects refrigerant leakage, the indoor unit will display a error code and emit a buzzing sound, the compressor of outdoor unit will immediately stop, and the indoor fan will start running. The service life of the refrigerant sensor is 15 years. When the refrigerant sensor malfunctions, the indoor unit will display the error code "FHCC". The refrigerant sensor can not be repaired and can only be replaced by the manufacturer. It shall only be replaced with the sensor specified by the manufacturer.

2. Because a FLAMMABLE REFRIGERANT is used, the requirements for installation space of appliance and/or ventilation requirements are determined according to:

- the mass charge amount(M) used in the appliance,
- the installation location,
- the type of ventilation of the location or of the appliance.
- piping material, pipe routing, and installation shall include protection from physical damage in operation and service, and be in compliance with national and local codes and standards, such as ASHRAE 15, IAPMO Uniform Mechanical Code, ICC International Mechanical Code, or CSA B52. All field joints shall be accessible for inspection prior to being covered or enclosed.
- that protection devices, piping, and fittings shall be protected as far as possible against adverse environmental effects, for example, the danger of water collecting and freezing in relief pipes or the accumulation of dirt and debris;
- that piping in refrigeration systems shall be so designed and installed to minimize the likelihood of hydraulic shock damaging the system;
- that steel pipes and components shall be protected against corrosion with a rustproof coating before applying any insulation;
- that precautions shall be taken to avoid excessive vibration or pulsation;
- the minimum floor area of the room shall be mentioned in the form of a table or a single figure without reference to a formula;
- After completion of field piping for split systems, the field pipework shall be pressure tested with OXYGEN-FREE NITROGEN (OFN) and then vacuum tested prior to refrigerant charging, according to the following requirements:
 1. Pressure test the refrigerant piping to 500 PSI.
 2. The test pressure after removal of pressure source shall be maintained for at least 1 hour with no decrease of pressure indicated by the test gauge, with test gauge resolution not exceeding 5% of the test pressure.
 3. During the evacuation test, after achieving a vacuum level specified in the manual or less, the refrigeration system shall be isolated from the vacuum pump and the pressure shall not rise above 1500 microns within 10 min. The vacuum pressure level shall be specified in the manual, and shall be the lessor of 500 microns or the value required for compliance with national and local codes and standards, which may vary between residential, commercial, and industrial buildings.
- Field-made refrigerant joints indoors shall be tightness tested according to the following requirements: The test method shall have a sensitivity of 0.18 oz (5 g) per year of refrigerant or better under a pressure of at least 125% of the maximum allowable pressure. No leak shall be detected.

3 . Qualifications Of Workers

Any maintenance, service and repair operations must be performed by qualified personnel. Any working procedure that impacts safety must be performed only by qualified individuals who have completed the necessary training and obtained certification to demonstrate their competence. The training of these procedures is carried out by national training organizations or manufacturers that are accredited to teach the relevant national competency standards that may be set in legislation. All training shall follow the ANNEX HH requirements of UL 60335-2-40 4th Edition.

Examples for such working procedures are:

- breaking into the refrigerating circuit;
- opening of sealed components;
- opening of ventilated enclosures.

4. Checks To The Area

Prior to beginning work on systems containing flammable refrigerants, safety checks are necessary to ensure that the risk of ignition is minimized. For repair to the refrigerating system, the following precautions shall be complied with prior to conducting work on the system.

5. Work Procedure

Works shall be undertaken under a controlled procedure so as to minimize the risk of a flammable gas or vapor being present while the work is being performed.

6. General Work Area

All maintenance staff and others working in the local area shall be instructed on the nature of work being carried out. Working in confined spaces shall be avoided.

7. Checking For Presence Of Refrigerant

The area shall be checked with an appropriate refrigerant detector prior to and during work, to ensure the technician is aware of potentially flammable atmospheres. Ensure that the leak detection equipment being used is suitable for use with flammable refrigerants, i.e. no sparking, adequately sealed or intrinsically safe.

8. Presence Of Fire Extinguisher

If any hot work is to be conducted on the refrigeration equipment or any associated parts, appropriate fire extinguishing equipment shall be available to hand. Have a dry power or CO2 fire extinguisher adjacent to the charging area.

9. No Ignition Sources

No person carrying out work in relation to a REFRIGERATING SYSTEM which involves exposing any pipe work shall use any sources of ignition in such a manner that it may lead to the risk of fire or explosion. All possible ignition sources, including cigarette smoking, should be kept sufficiently far away from the site of installation, repairing, removing and disposal, during which refrigerant can possibly be released to the surrounding space. Prior to work taking place, the area around the equipment is to be surveyed to make sure that there are no flammable hazards or ignition risks.

"No Smoking" signs shall be displayed.

10. Ventilated Area

Ensure that the area is in the open or that it is adequately ventilated before breaking into the system or conducting any work that could produce ignition. Keep ventilation openings clear of obstruction. Ventilation continue during the period that the work is carried out. Proper ventilation should safely disperse any released refrigerant and preferably expel it externally into the atmosphere.

11. Checks To The Refrigeration Equipment

Where electrical components are being changed, they shall be fit for the purpose and to the correct specification. At all times the manufacturer's maintenance and service guidelines shall be followed. If in doubt consult the manufacturer's technical department for assistance. The following checks shall be applied to installations using FLAMMABLE REFRIGERANTS:

- the actual refrigerant charge is in accordance with the room size within which the refrigerant containing parts are installed;
- the ventilation machinery and outlets are operating adequately and are not obstructed;
- if an indirect refrigerating circuit is being used, the secondary circuits shall be checked for the presence of refrigerant;
- marking to the equipment continues to be visible and legible, marking and signs that are illegible shall be corrected;
- refrigeration pipe or components are installed in a position where they are unlikely to be exposed to any substance which may corrode refrigerant containing components, unless the components are constructed of materials which are inherently resistant to being corroded or are suitably protected against being so corroded.

12. Checks To Electrical Devices

Repair and maintenance to electrical components shall include initial safety checks and component inspection procedures. If a fault exists that could compromise safety, then no electrical supply shall be connected to the circuit until it is satisfactorily dealt with. If the fault cannot be corrected immediately but it is necessary to continue operation, and adequate temporary solution shall be used. This shall be reported to the owner of the equipment so all parties are advised. Initial safety checks shall include:

- that capacitors are discharged: this shall be done in a safe manner to avoid possibility of sparking;
- that there no live electrical components and wiring are exposed while charging, recovering or purging the system;
- that there is continuity of earth bonding;
- Sealed electrical components shall be replaced if it's damage;
- Intrinsically safe components must be replaced if it's damage.

13. Wiring

Check that wiring will not be subject to wear, corrosion, excessive pressure, vibration, sharp edges or any other adverse environmental effects. The check shall also take into account the effects of aging or continual vibration from sources such as compressors or fans.

14. Detection Of Flammable Refrigerants

Under no circumstances shall potential sources of ignition be used in the searching for or detection of refrigerant leaks. A halide torch (or any other detector using a naked flame) shall not be used.

The following leak detection methods are deemed acceptable for refrigerant systems:

- Electronic leak detectors may be used to detect refrigerant leaks but, in the case of FLAMMABLE REFRIGERANTS, the sensitivity may not be adequate, or may need re-calibration to a sensitivity of 0.18 oz (5 g) per year. (Detection equipment shall be calibrated in a refrigerant free area.) Ensure that the detector is not a potential source of ignition and is suitable for the refrigerant used. Leak detection equipment shall be set at a percentage of the LFL of the refrigerant and shall be calibrated to the refrigerant employed, and the appropriate percentage of gas (25 % maximum) is confirmed.
- Leak detection fluids are also suitable for use with most refrigerants but the use of detergents containing chlorine shall be avoided as the chlorine may react with the refrigerant and corrode the copper pipe-work.

**Note**

Examples of leak detection fluids are bubble method and fluorescent method agents.

If a leak is suspected, all naked flames shall be removed/extinguished.

If a leakage of refrigerant is found which requires brazing, all of the refrigerant shall be recovered from the system, or isolated (by means of shut off valves) in a part of the system remote from the leak. See the following instructions for removal of refrigerant.

15. Evacuation

When breaking into the refrigerant circuit to make repairs – or for any other purpose conventional procedures shall be used. However, for flammable refrigerants it is important that best practice be followed, since flammability is a consideration.

The following procedure shall be adhered to:

- safely remove refrigerant following local and national regulations; evacuate;
- purge the circuit with NITROGEN
- evacuate (requirement);
- continuously flush or purge with NITROGEN when using flame to open circuit; and
- open the circuit

The refrigerant charge shall be recovered into the correct recovery cylinders if venting is not allowed by local and national codes. For appliances containing flammable refrigerants, the system shall be purged with OXYGEN-FREE NITROGEN (OFN) to render the appliance safe for flammable refrigerants. This process might need to be repeated several times. Compressed air or oxygen **shall not be used** for purging refrigerant systems.

For appliances containing flammable refrigerants, refrigerant purging shall be achieved by breaking the vacuum in the system with OXYGEN-FREE NITROGEN (OFN) and continuing to fill until the working pressure is achieved, then venting to atmosphere, and finally pulling down to a vacuum (requirement). This process shall be repeated until no refrigerant is within the system (requirement). When the final oxygen-free nitrogen charge is used, the system shall be vented down to atmospheric pressure to enable work to take place.

The outlet for the vacuum pump shall not be close to any potential ignition sources, and ventilation shall be available.

16. Charging Procedures

In addition to conventional charging procedures, the following requirements shall be followed:

- Works shall be undertaken with appropriate tools only (In case of uncertainty, please consult the manufacturer of the tools for use with flammable refrigerants).
- Ensure that contamination of different refrigerants does not occur when using charging equipment.
- Hoses or lines shall be as short as possible to minimize the amount of refrigerant contained in them.
- Cylinders shall be kept upright.
- Ensure that the refrigeration system is grounded prior to charging the system with refrigerant.
- Label the system when charging is complete (if not already).
- Extreme care shall be taken not to overfill the refrigeration system.
- Prior to recharging the system it shall be pressure tested with OXYGEN FREE NITROGEN (OFN). The system shall be leak tested on completion of charging but prior to commissioning.
- A follow up leak test shall be carried out prior to leaving the site.

17. Decommissioning

Before carrying out this procedure, it is essential that the technician is completely familiar with the equipment and all its detail. It is recommended good practice that all refrigerants are recovered safely. Prior to the task being carried out, an oil and refrigerant sample shall be taken in case analysis is required prior to re-use of recovered refrigerant. It is essential that electrical power is available before the task is commenced.

- Become familiar with the equipment and its operation.
- Isolate system electrically
- Before attempting the procedure ensure that:
 1. mechanical handling equipment is available, if required, for handling refrigerant cylinders;
 2. all personal protective equipment is available and being used correctly;
 3. the recovery process is supervised at all times by a competent person;
 4. recovery equipment and cylinders conform to the appropriate standards.
- Pump down refrigerant system, if possible.
- If a vacuum is not possible, make a manifold so that refrigerant can be removed from various parts of the system.
- Make sure that cylinder is situated on the scales before recovery takes place.
- Start the recovery machine and operate in accordance with instructions.
- Do not overfill cylinders (no more than 80 % volume liquid charge)
- Do not exceed the maximum working pressure of the cylinder, even temporarily.
- When the cylinders have been filled correctly and the process completed, make sure that the cylinders and the equipment are removed from site promptly and all isolation valves on the equipment are closed off.
- Recovered refrigerant shall not be charged into another refrigeration system unless it has been cleaned and checked.

18. Labeling

Equipment shall be labeled stating that it has been decommissioned and emptied of refrigerant. The label shall be dated and signed. For appliances containing FLAMMABLE REFRIGERANTS, ensure that there are labels on the equipment stating the equipment contains FLAMMABLE REFRIGERANT.

19. Recovery

When removing refrigerant from a system, either for servicing or decommissioning, it is recommended good practice that all refrigerants are removed safely. When transferring refrigerant into cylinders, ensure that only appropriate refrigerant recovery cylinders are employed. Ensure that the correct number of cylinders for holding the total system charge is available. All cylinders to be used are designated for the recovered refrigerant and labeled for that refrigerant (i. e. special cylinders for the recovery of refrigerant). Cylinders shall be complete with pressure-relief valve and associated shut-off valves in good working order. Empty recovery cylinders are evacuated and, if possible, cooled before recovery occurs.

The recovery equipment shall be in good working order with a set of instructions concerning the equipment that is at hand and shall be suitable for the recovery of the flammable refrigerant. If in doubt, the manufacturer should be consulted. In addition, a set of calibrated weighing scales shall be available and in good working order. Hoses shall be complete with leak-free disconnect couplings and in good condition.

The recovered refrigerant shall be processed according to local legislation in the correct recovery cylinder, and the relevant waste transfer note arranged. Do not mix refrigerants in recovery units and especially not in cylinders.

If compressors or compressor oils are to be removed, ensure that they have been evacuated to an acceptable level to make certain that flammable refrigerant does not remain within the lubricant. The compressor body shall not be heated by an open flame or other ignition sources to accelerate this process. When oil is drained from a system, it shall be carried out safely.

20. Unventilated Areas

- An unventilated area where the appliance using FLAMMABLE REFRIGERANTS is installed shall be so constructed that should any refrigerant leak, it will not stagnate so as to create a fire or explosion hazard.
- If appliances connected via an air duct system to one or more rooms with A2L REFRIGERANTS are installed in a room with an area less than A_{min} , that room shall be without continuously operating open flames (e.g. an operating gas appliance) or other POTENTIAL IGNITION SOURCES (for e.g. an operating electric heater, hot surfaces). A flame-producing device may be installed in the same space if the device is provided with an active flame arrest.
- Auxiliary devices which may be a POTENTIAL IGNITION SOURCE shall not be installed in the duct work. Examples of such POTENTIAL IGNITION SOURCES are hot surfaces with a temperature exceeding 700 °C and electric switching devices.
- Only auxiliary devices (such as certificated heater kit) approved by the appliance manufacturer or declared suitable with the refrigerant shall be installed in connecting ductwork.
- For duct connected appliances, false ceilings or drop ceilings may be used as a return air plenum if a REFRIGERANT DETECTION SYSTEM is provided in the appliance and any external connections are also provided with a sensor immediately below the return air plenum duct joint.
- REFRIGERANT SENSORS for REFRIGERANT DETECTION SYSTEMS shall only be replaced with sensors specified by the appliance manufacture.
- LEAK DETECTION SYSTEM installed. Unit must be powered except for service.

21. Transportation, Marking and Storage for Units That Employ Flammable Refrigerants

The following information is provided for units that employ FLAMMABLE REFRIGERANTS

Transport of equipment containing flammable refrigerants: Attention is drawn to the fact that additional transportation regulations may exist with respect to equipment containing flammable gas. The maximum number of pieces of equipment or the configuration of the equipment permitted to be transported together will be determined by the applicable transport regulations.

Marking of equipment using signs: Signs for similar appliances used in a work area are generally addressed by local regulations and give the minimum requirements for the provision of safety and/or health signs for a work location. All required signs are to be maintained and employers should ensure that employees receive suitable and sufficient instruction and training on the meaning of appropriate safety signs and the actions that need to be taken in connection with these signs. The effectiveness of signs should not be diminished by too many signs being placed together. Any pictograms used should be as simple as possible and contain only essential details.

Disposal of equipment using flammable refrigerants: See national regulations.

Storage of equipment/appliances: The storage of the appliance should be in accordance with

the applicable regulations or instructions, whichever is more stringent.

Storage of packed (unsold) equipment: Storage package protection should be constructed in such a way that mechanical damage to the equipment inside the package will not cause a leak of the REFRIGERANT CHARGE. The maximum number of pieces of equipment permitted to be stored together will be determined by local regulations.



Additional Precautions

- Turn off the air conditioner and disconnect the power if you are not going to use it for a long time.
- Turn off the unit during electrical storms to avoid damaging the unit.
- Make sure that water condensation can drain unhindered from the unit.
- Do not operate the air conditioner with wet hands. This may cause electric shock.
- Do not use this device for any other purpose than its intended use.
- Do not climb onto or place objects on top of the outdoor unit.
- Do not allow the air conditioner to operate for long periods of time with doors or windows open, or if the humidity is very high.
- If the air handler is used together with burners or other heating devices, thoroughly ventilate the room to avoid oxygen deficiency and carbon monoxide build up.
- In certain environments, such as kitchens, server rooms, etc., the use of specially designed air-conditioning units is highly recommended.
- As with any mechanical equipment, contact with sharp sheet metal edges can result in personal injury. Take care while handling this equipment and wear gloves and protective clothing.
- Excessive Weight Hazard - Use two (2) or more people when moving and installing the unit. Failure to do so can result in back or other type of injury.

Specifications of R-454B Refrigerant

- **Application: R-454B is not a drop-in replacement for R-410A.** The equipment design must accommodate the A2L safety group of R-454B. It cannot be used in R-410A systems.
- **Physical Properties:** R-454B has an atmospheric bubble point of -59.6 °F (-50.9 °C) and an atmospheric dew point of -58.0 °F (-50.0 °C). Its bubble point saturation pressure at 77 °F (25 °C) is 213 psig (1469 kPa) and dew point saturation pressure at 77 °F (25 °C) is 205 psig (1415 kPa).
- **Composition:** R-454B is classified as safety group A2L per ASHRAE Standard 34. Verify that service equipment and instruments are certified for use with group A2L refrigerants, and in particular with R-454B is a non-azeotropic mixture of 68.9% by weight difluoromethane (HFC-32) and 31.1 % by weight 2,3,3,3-tetrafluoro-1-propene (HFO-1234yf).

R454B REQUIRED MINIMUM ROOM AREA

Minimum Room Area

R454B UL guidelines mandate that refrigerant dissipation measures be implemented in the event of a leak, determined by the total area of the installation and the overall system charge. The total system charge includes any component that holds refrigerant, including line sets, indoor coils, and outdoor units. The minimum room area for operating and storing the unit should be as specified in the following table.

TA_{min}: REQUIRED MINIMUM ROOM AREA: ft² (m²)

M _c or M _{REL} [oz/kg]	TA _{min} [ft ² /m ²]	M _c or M _{REL} [oz/kg]	TA _{min} [ft ² /m ²]	M _c or M _{REL} [oz/kg]	TA _{min} [ft ² /m ²]	M _c or M _{REL} [oz/kg]	TA _{min} [ft ² /m ²]
≤ 62.7/1.7	12/1.1	134/3.8	126/11.67	211.6/6.0	198/18.43	289.2/8.2	271/25.18
63.5/1.8	60/5.53	141.1/4	132/12.29	218.7/6.2	205/19.04	296.3/8.4	278/25.8
70.5/2	66/6.14	148.1/4.2	139/12.9	225.8/6.4	212/19.66	303.4/8.6	284/26.41
77.6/2.2	73/6.76	155.2/4.4	145/13.51	232.8/6.6	218/20.27	310.4/8.8	291/27.63
84.6/2.4	79/7.37	162.2/4.6	152/14.13	239.9/6.8	225/20.88	317.5/9.0	298/27.64
91.72.6	86/7.99	169.3/4.8	159/14.74	246.9/7.0	231/21.5	324.5/9.2	304/28.26
98.8/2.8	93/8.6	176.4/5	165/15.36	254/7.2	238/22.11	331.6/9.4	311/28.87
105.8/3	99/9.21	183.4/5.2	172/15.97	261/7.4	245/22.73	338.6/9.6	317/29.48
112.9/3.2	106/9.83	190.5/5.4	179/16.58	268.1/7.6	251/23.34	345.7/9.8	324/30.10
119.9/3.4	112/10.44	197.5/5.6	185/17.2	275.1/7.8	258/23.96	352.7/10.0	331/30.71
127/3.6	119/11.06	204.6/5.8	192/17.81	282.2/8.0	264/24.57		
Variable Definitions	<p>TA_{min}: the required minimum room area in ft² (m²) M_c: the actual refrigerant charge in the system in lbs (kg) M_{REL}: the refrigerant releasable charge in lbs (kg)</p> <p>WARNING: The minimum room area or the minimum room area of conditioned space is based on releasable charge and total system refrigerant charge.</p>						

When the unit detects a refrigerant leak, the minimum airflow of the indoor unit is as follows :

Model	DRUM1824S2A	DRUM3036S2A		DRUM4260S2A	
BTU	18K - 24K	30K	36K	42-48K	60K
Nominal Air Volume	400 CFM (680m ³ /h)	447 CFM (760m ³ /h)	541 CFM (920m ³ /h)	706 CFM (1200m ³ /h)	824 CFM (1400m ³ /h)

TAKE NOTE OF THE FUSE SPECIFICATIONS

The air conditioner's circuit board (PCB) is designed with a fuse to provide over-current protection. The specifications of the fuse are printed on the circuit board, for example: T3.15AL/250VAC, T5AL/250VAC, T3.15A/250VAC, T5A/250VAC, T20A/250VAC, T30A/250VAC, etc.

**Note**

Only a blast-proof ceramic fuse can be used.

ALLOWED STATIC PRESSURE

The allowed static pressure range of the air handler is 0–0.80 in-H₂O (0–200 Pa). The airflow decreases below 0.80 in WC or 200Pa and system design should allow for the increased resistance as filters become dirty.

The data below represents the static pressures at full required air flow used for AHRI testing:

Model	DRUM1824S2A	DRUM3036S2A	DRUM4260S2A
Pressure	0.5 in-H ₂ O (125 Pa)	0.5 in-H ₂ O (125 Pa)	0.5 in-H ₂ O (125 Pa)

COMPATIBILITY AND SPECIFICATION OVERVIEW

	OUTDOOR MODEL (208/230V)	AIR HANDLER MODEL (115 ¹ /208/230V)	BTUH	LIQUID PIPE (in (mm))	SUCTION PIPE (in (mm))	AIR HANDLER NET WEIGHT (lbs (kg))
STANDARD	DRU1U18S2A	DRUM1824S2A	18,000	3/8 (9.52)	3/4 (19) ²	106 (48)
	DRU1U24S2A		24,000	3/8 (9.52)	3/4 (19)	
	DRU1U30S2A	DRUM3036S2A	30,000	3/8 (9.52)	3/4 (19)	129 (59)
	DRU1U36S2A		36,000	3/8 (9.52)	3/4 (19)	
	DRU1U48S2A	DRUM4260S2A	48,000	3/8 (9.52)	3/4 (19)	163 (74)
	DRU1U60S2A		60,000	3/8 (9.52)	3/4 (19)	
SIRIUS HEAT	DRU1H18S2A	DRUM1824S2A	18,000	3/8 (9.52)	3/4 (19)	106 (48)
	DRU1H24S2A		24,000	3/8 (9.52)	3/4 (19)	
	DRU1H30S2A	DRUM3036S2A	30,000	3/8 (9.52)	3/4 (19)	129 (59)
	DRU1H36S2A		36,000	3/8 (9.52)	3/4 (19)	
	DRU1H42S2A	DRUM4260S2A	42,000	3/8 (9.52)	3/4 (19)	163 (74)
	DRU1H48S2A		48,000	3/8 (9.52)	3/4 (19)	
	DRU1H49S2A		48,000	3/8 (9.52)	3/4 (19)	
	DRU1H60S2A		60,000	3/8 (9.52)	3/4 (19)	

¹Unit needs to be field converted to 115V according to the instructions in this manual

²Adapter included with the DRU1U18S2A must be used to match the air handler suction pipe size.

OPERATING TEMPERATURES

Your air handler is designed to operate in the following indoor and outdoor temperatures. When your air handler is used outside of the following temperature ranges, certain safety features may activate and turn off the unit to protect it from damage. We strongly suggest keeping the unit plugged in at all times when temperatures are below 32°F (0°C) for smooth operation.

TEMPERATURE RANGES

	COOL mode	HEAT mode	DRY mode
Indoor Air Temperature	60°F - 90°F (16°C - 32°C)	32°F - 86°F (0°C - 30°C)	50°F - 90°F (10°C - 32°C)
Outdoor Air Temperature	-13°F / -22°F* - 122°F (-25°C / -30°C* - 50°C)	-13°F / -22°F* - 75°F (-25°C / -30°C* - 24°C)	32°F - 122°F (0°C - 50°C)







* The minimum operating temperature depends on the outdoor unit. Low ambient Sirius Heat™ models have a minimum operating temperature in heat mode of -22°F (-30°C).

- Keep doors and windows closed.
- Limit energy usage by using TIMER ON and TIMER OFF features.
- Do not block air inlets or outlets.
- Regularly inspect and clean air filters.

ACCESSORIES

INCLUDED INSTALLATION ACCESSORIES

The air conditioning system comes with the following accessories. These are usually packaged in the air outlet. Remove before install.

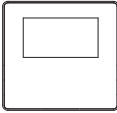
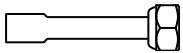
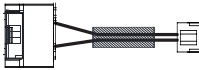
ACCESSORY	QUANTITY	IMAGE	ACCESSORY	QUANTITY	IMAGE
Manual	2		Cable Ties	6	
Remote Control	1		Insulation Sleeve	2	
Battery	2		Flare Nut	2	
Wired Remote Controller (DRSTAT101)	1		Braze To Flare Adapter	2	
115V Conversion Plug	1		3rd Party Outdoor Unit Compatibility Adapter	1	<u>5-pin wire only used to connect to a 3rd party unit</u>

NOTE



The Durastar wired control (DRSTAT101) functions as an IR receiver for the handheld remote. If the remote is not used, it must be retained with the indoor unit to adjust parameters and for troubleshooting.

FIELD SUPPLIED INSTALLATION ACCESSORIES

The following installation accessories are required and must be purchased separately.

- Refrigerant piping (line set)
- Filter
- Indoor and outdoor connection wire
- Outdoor power supply cord
- Drain pipe
- Pipe and cable wrapping tape
- Wall hole sleeve and cover
- Putty
- Wiring u-lugs



WARNING

Ensure that all service equipment and instruments are certified for use with group A2L refrigerants, specifically R-454B. Recovery equipment, pumps, hoses, and related components must be rated for the appropriate design pressures for R-454B. Manifold sets should accommodate pressures up to 800 psig on the high side and 250 psig on the low side, with a 550 psig low-side retard. Hoses must have a service pressure rating of 800 psig, while recovery cylinders should be rated for 400 psig, meeting DOT 4BA400 or DOT 4BW400 standards.

TOOLS NEEDED

The following tools are required for installation.

- Vacuum pump
- HVAC manifold gauge set
- Micron Gauge
- Refrigerant leak detector
- Copper pipe cutter
- Phillips screwdriver
- Drill with 2 1/2" or 3 1/2" (indoor unit model depending) core bit
- Flaring tool
- Burr reamer
- Crescent or spanner wrench
- Hexagonal wrench set
- Torque wrench
- Multimeter
- Electro-probe
- Level
- Hammer
- Wire strippers
- Wire crimper

UNIT DIMENSIONS

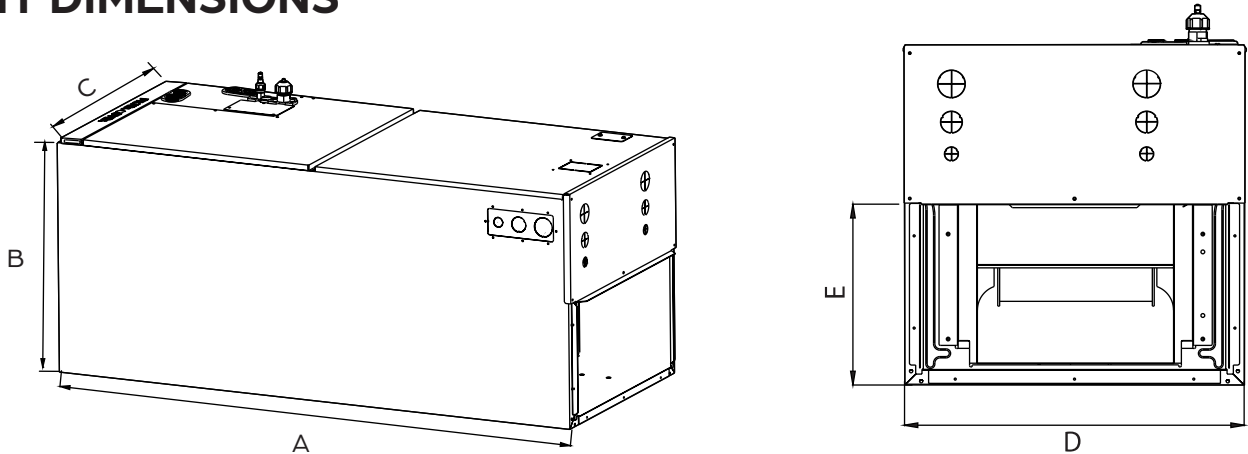

MODEL	DIMENSIONS				
	A (Height) in (mm)	B (Depth) in (mm)	C (Width) in (mm)	D in (mm)	E in (mm)
DRUM1824S2A	45 (1143)	21 (533)	17-1/2 (445)	15-3/4 (400)	10-1/4 (260)
DRUM3036S2A	49 (1245)	21 (533)	21 (533)	19-5/16 (490)	10-1/4 (260)
DRUM4260S2A	53 (1346)	21 (533)	24-1/2 (622)	22-7/8 (580)	10-1/4 (260)

FILTER SIZE

MODEL	DRUM1824S2A	DRUM3036S2A	DRUM4260S2A
WIDTH (in (mm))	16 (406)	20 (495)	24 (584)
DEPTH (in (mm))	20 (508)	20 (508)	20 (508)
THICKNESS (in (mm))	1 (25)	1 (25)	1 (25)

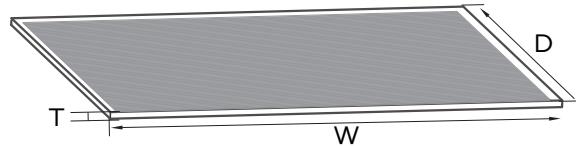

PARTS IDENTIFICATION

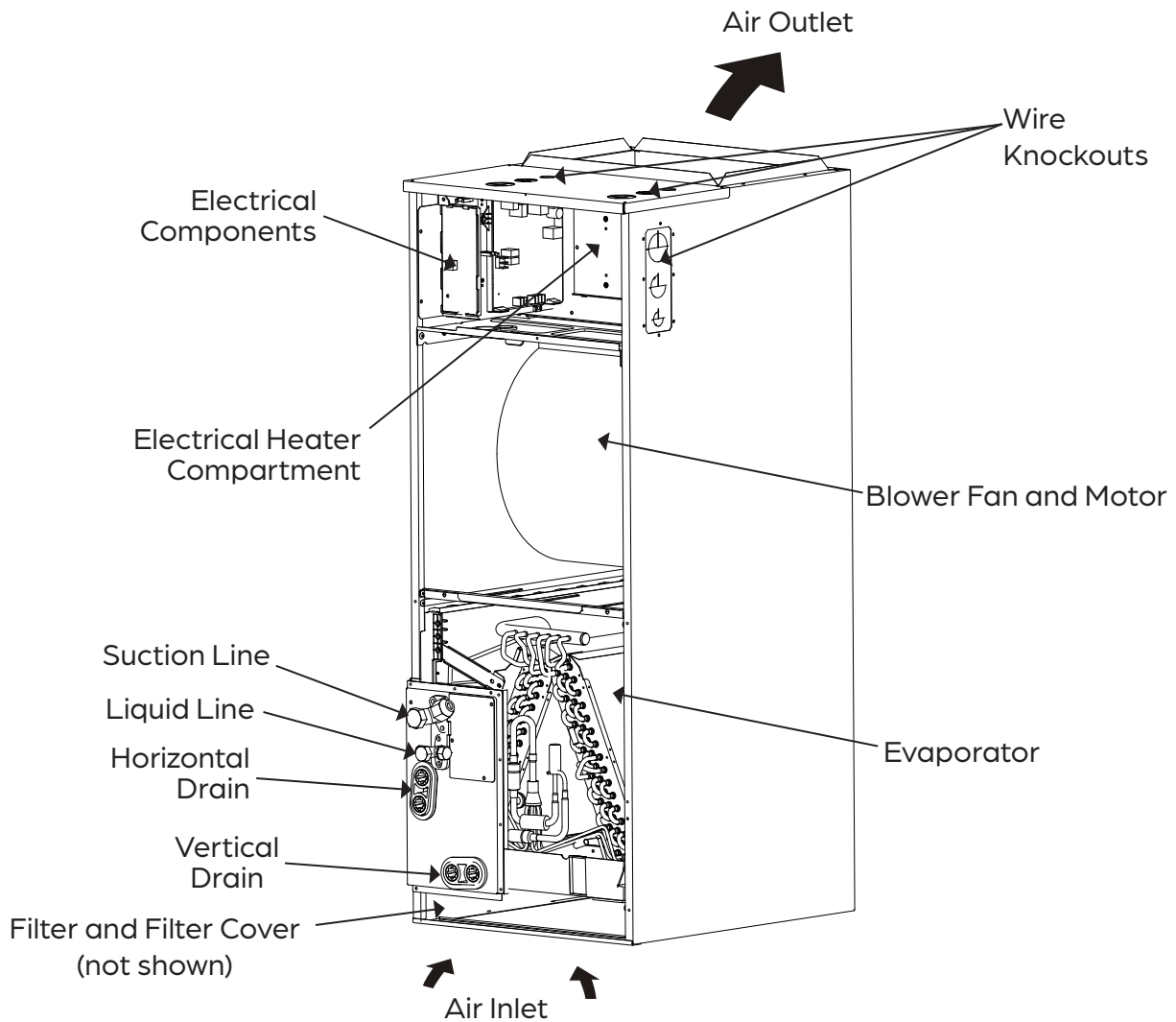

NOTE

Illustrations in this manual are for explanatory purposes. The actual shape of your equipment may vary slightly.

INSTALLATION PREPARATION

**NOTE**

The installation must be performed in accordance with the required local and national standards. The installation may be slightly different in different areas.

SELECT INSTALLATION LOCATION

Before installing the indoor unit, you must choose an appropriate location. The following standards must be met for an appropriate location for the unit.

Install the unit:

- With enough room for installation (connecting pipe and drainage) and maintenance.
- On a structure that can support its weight. If the structure is too weak, the unit may fall and cause personal injury, unit and property damage, or death.
- With heating elements at least 18 inches above the floor in a garage. Failure to follow these instructions can result in death, explosion, or fire.
- Cables and wires at least three (3) feet / one (1) meter from televisions or radios to prevent static or image distortion. Depending on the appliances, a three (3) feet / one (1) meter distance may not be sufficient.

DO NOT install the unit in:

- A wet environment. Excessive moisture can corrode the equipment, electrical components, and cause electrical shorts.
- A coastal area with high salt content in the air.
- Areas with strong magnetic waves.
- Areas with oil drilling or fracking.
- Areas where there may be detergent or other corrosive gases in the air, such as bathrooms or laundry rooms.
- Areas that store flammable materials or gas. Danger of explosion. Keep flammable materials and vapors, such as gasoline, away from air handler.
- Areas where the air inlet or outlet of the indoor or outdoor unit may be obstructed.

**NOTE**

In addition, you must be aware of needed clearance space, installation direction, and duct requirements. These items are covered in the following pages.

RECOMMENDED CLEARANCE AROUND UNIT



NOTE

Leave 24" of clearance in front of the cabinet doors for service space.

Horizontal Installations

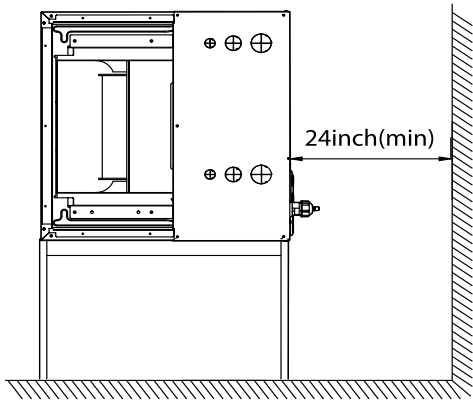

Horizontal installations

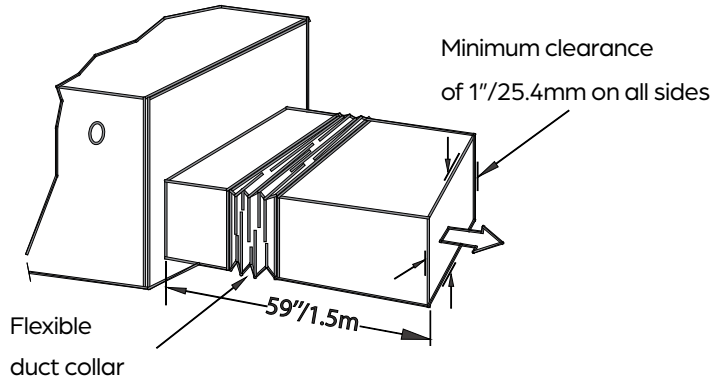

The outlet side pipe length 59"/1.5m.

Vertical Installations

When installed vertically (upward or downward), the lower end of the air outlet needs to be connected to the L-shaped metal air duct and fastened by screws.

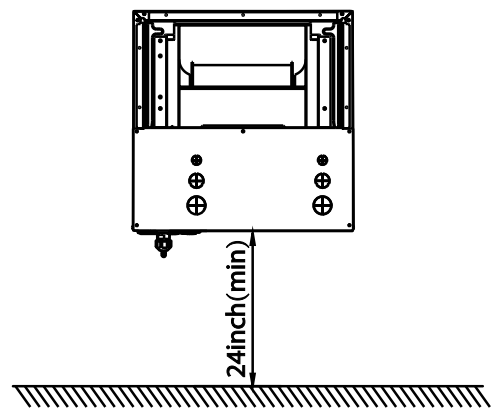
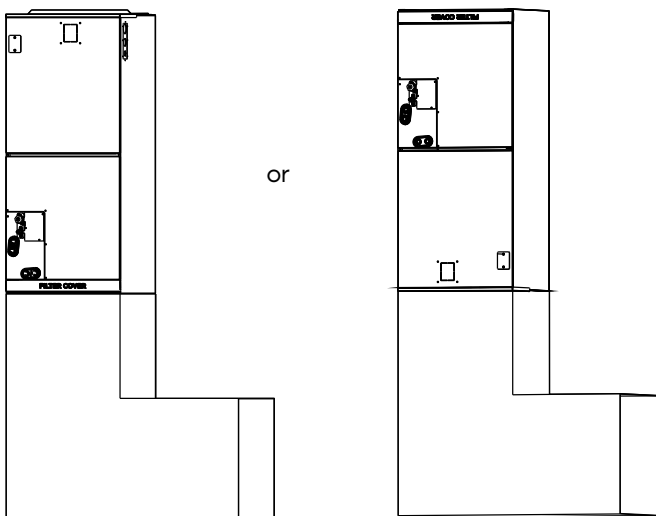

Vertical installations

DETERMINE INSTALLATION DIRECTION

The units can be installed in a vertical (up or down) or horizontal (right or left) configuration. Vertical down and horizontal right will require changing the direction of the evaporator coils.

WARNING



It is recommended that a field supplied secondary drain pan is installed with a cut-off switch. This is especially true when the installation is above or in a finished living space. Local codes may require this.

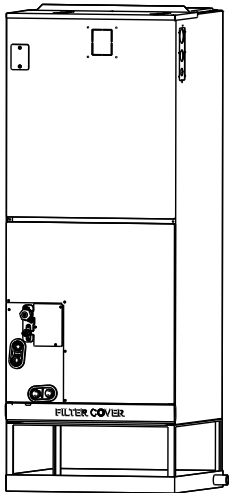

Vertical up

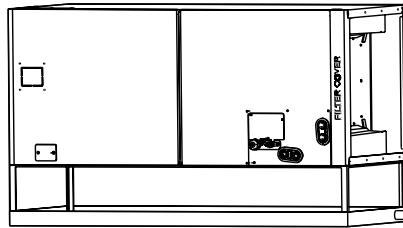

Horizontal

At least
3in(76mm)
Make sure wiring
is not laying in
the pan.

Airflow Direction

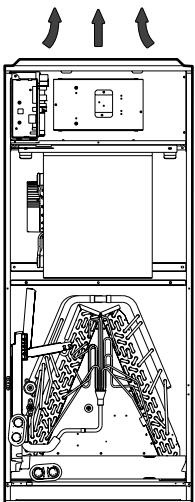

Upflow

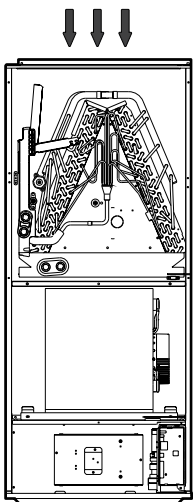

Downflow

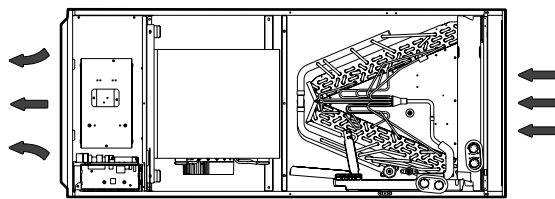

Horizontal left

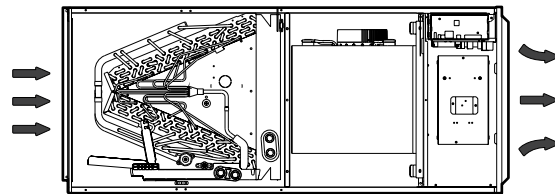

Horizontal right

NOTE



Vertical up and horizontal left installations do not need to change the direction of the evaporator.

CONVERSION INSTRUCTIONS FOR VERTICAL DOWN AND HORIZONTAL RIGHT INSTALLATION

STEP 1. REMOVE THE FILTER

Remove the filter door, then take the filter out.

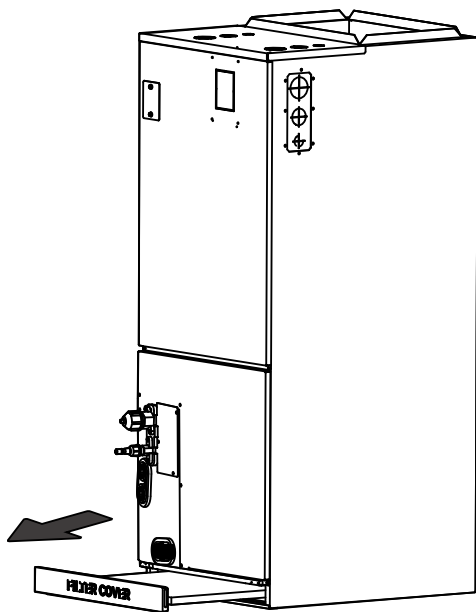

STEP 2. REMOVE THE UPPER COVER

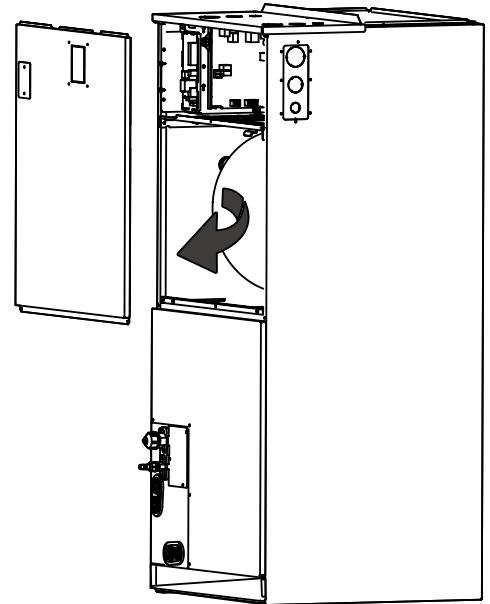

STEP 3. REMOVE THE EVAPORATOR COVER PLATE

Remove the bottom cover first, then remove the cover plate.

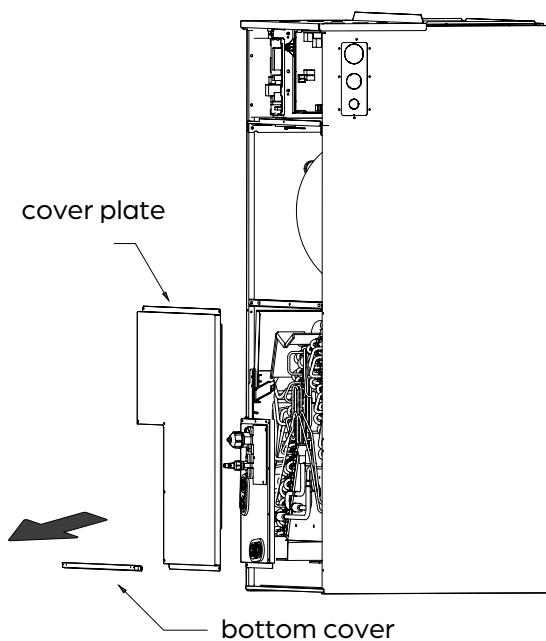

STEP 4. UNPLUG SENSORS T1, T2, T2A, T2B, RDS, AND EEV FROM THE CONTROL BOARD

T1: Room temperature sensor

T2: Evaporator central sensor plug (only some models)

T2A: Evaporator input sensor plug (only some models)

T2B: Evaporator output sensor plug

EEV: Electronic expansion valve

RDS: Refrigerant detection sensor

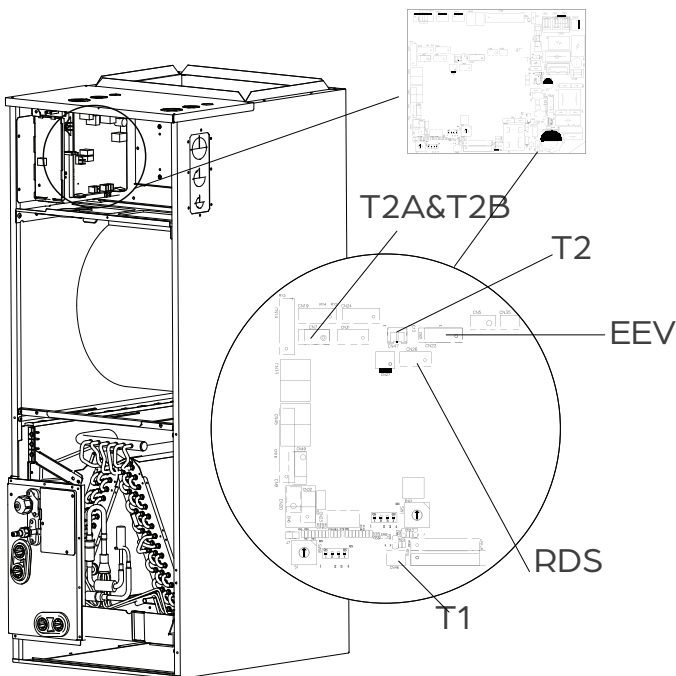

STEP 5. UNLATCH THE ADJUSTABLE WIRE TIES ON THE T1, T2, T2A, T2B, RDS, AND EEV SENSOR CABLES.

Loosen wire ties clamping wires to the coil as necessary to give slack.

DRUM1824S2A (18K - 24K)

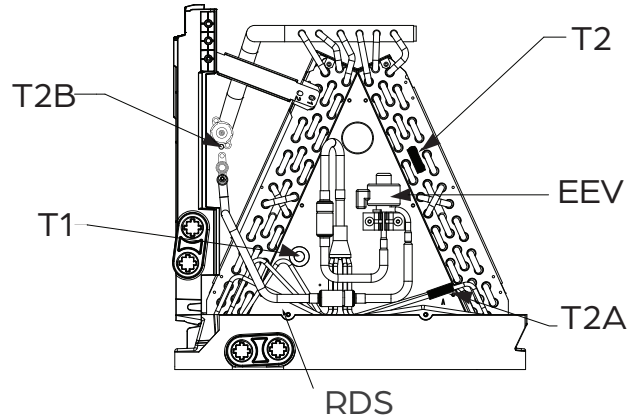

DRUM3036S2A (30K - 36K)

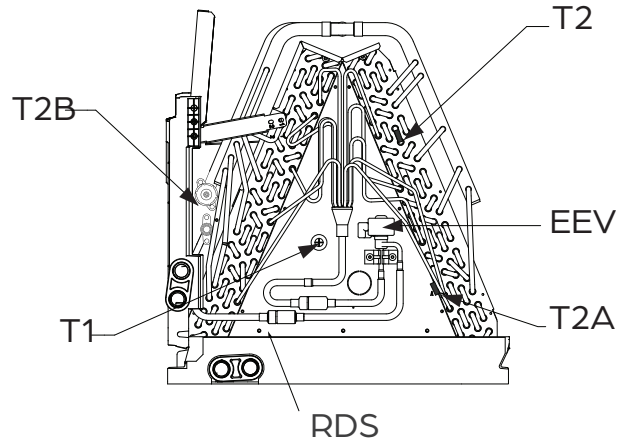

DRUM4248S2A (42K - 60K)

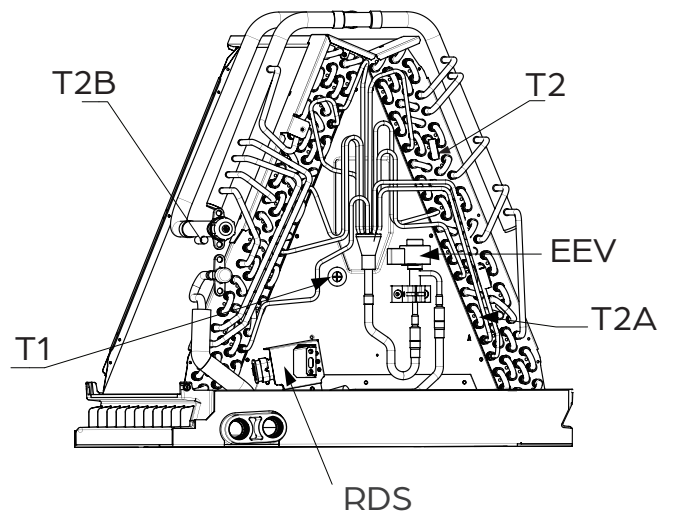

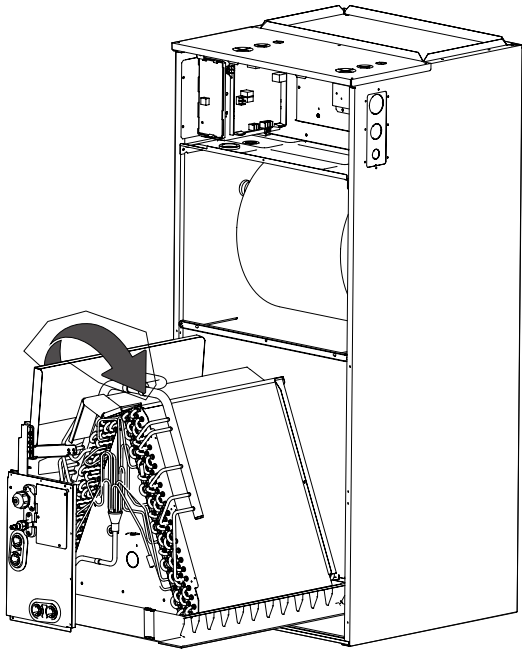
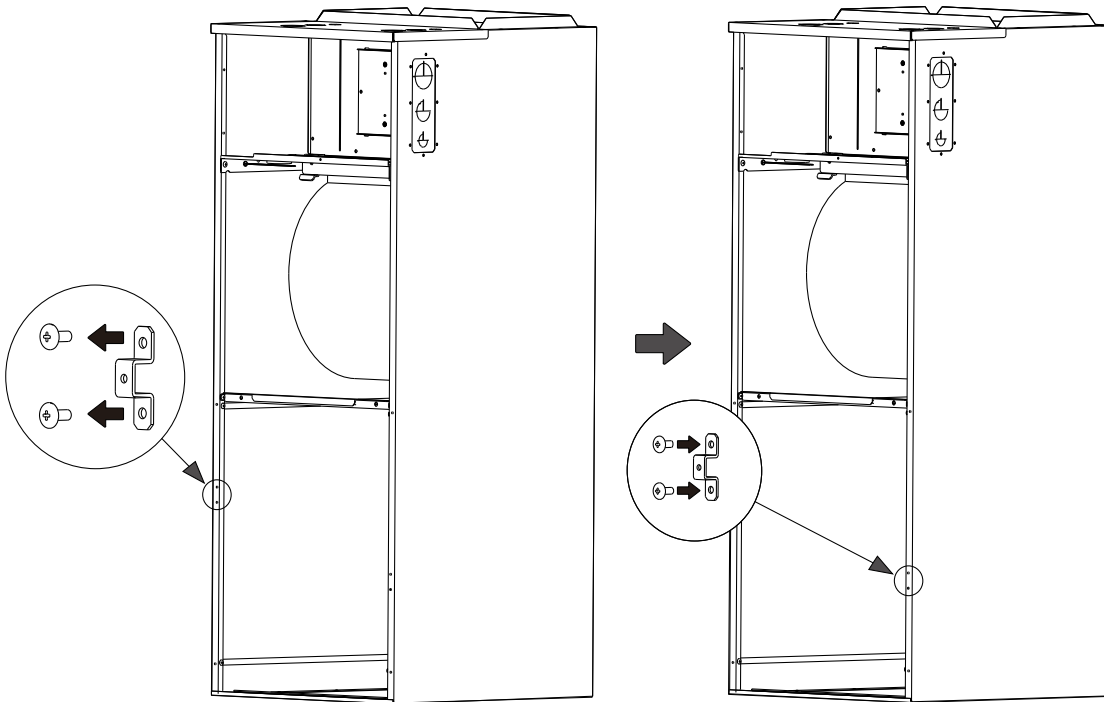
STEP 6. REMOVE THE EVAPORATOR AND DRAIN PAN.**STEP 7. ADJUST THE MOUNTING BRACKET TO THE PRE-DRILLED HOLES ON THE LEFT SIDE OF THE CABINET.**

STEP 8. ROTATE THE COIL 180 DEGREES AND REINSTALL THE EVAPORATOR AND DRAIN PAN.

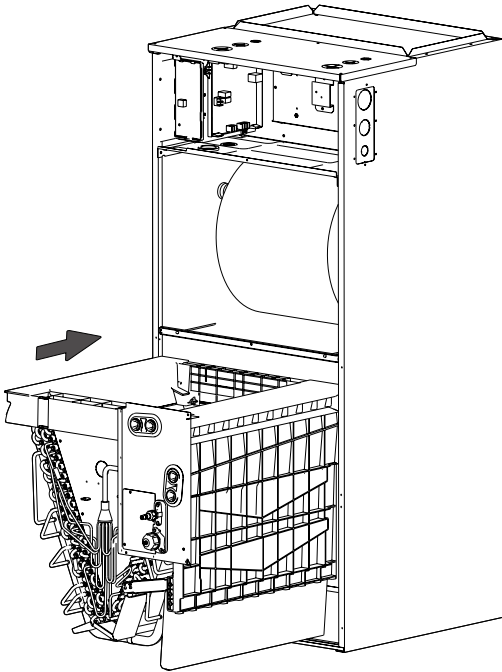

STEP 9. REINSTALL T1, T2 SENSOR PLUGS AND TIE UP THE SENSOR WIRES

The wire body needs to pass through the wire groove from the drain pan and be stuck on the hook of the drain pan.

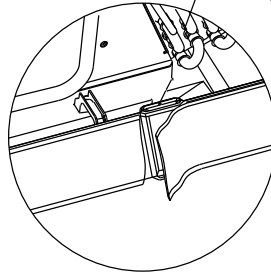
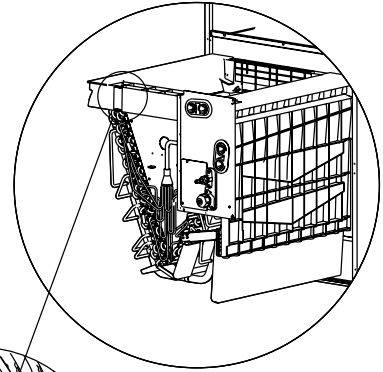

Cut the foam gasket.

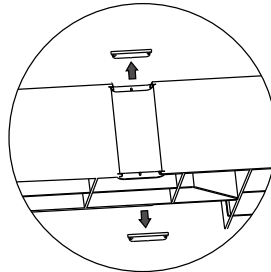

Remove knockouts as shown in the figure.

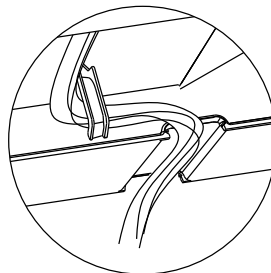

Hook the wire into the buckle and go down from the wire slot.

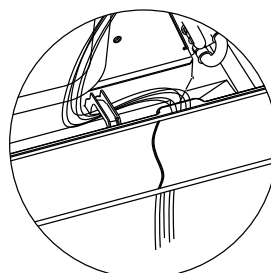

Replace foam gasket over wires.

STEP 10. USE CABLE TIES TO FIX THE ROOM TEMPERATURE SENSOR WIRE TO THE PIPES ON THE TOP OF THE EVAPORATOR.

Leave the sensor overhanging enough to not be affected by the temperature of the pipe.

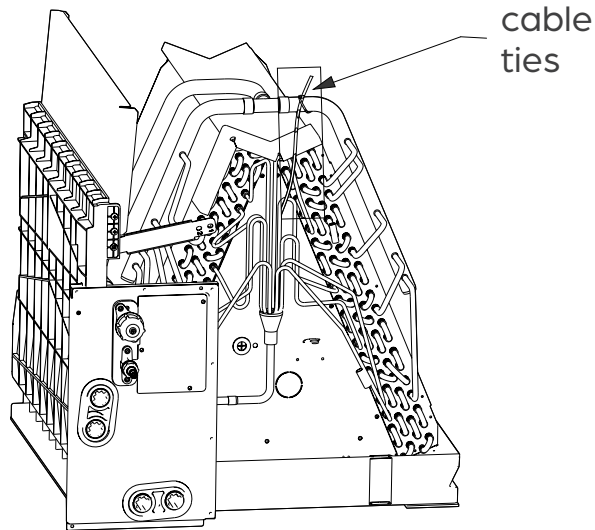
**STEP 11. REINSTALL THE EVAPORATOR AND FILTER COVER PLATES.**

Place unit into desired downflow or horizontal right position.

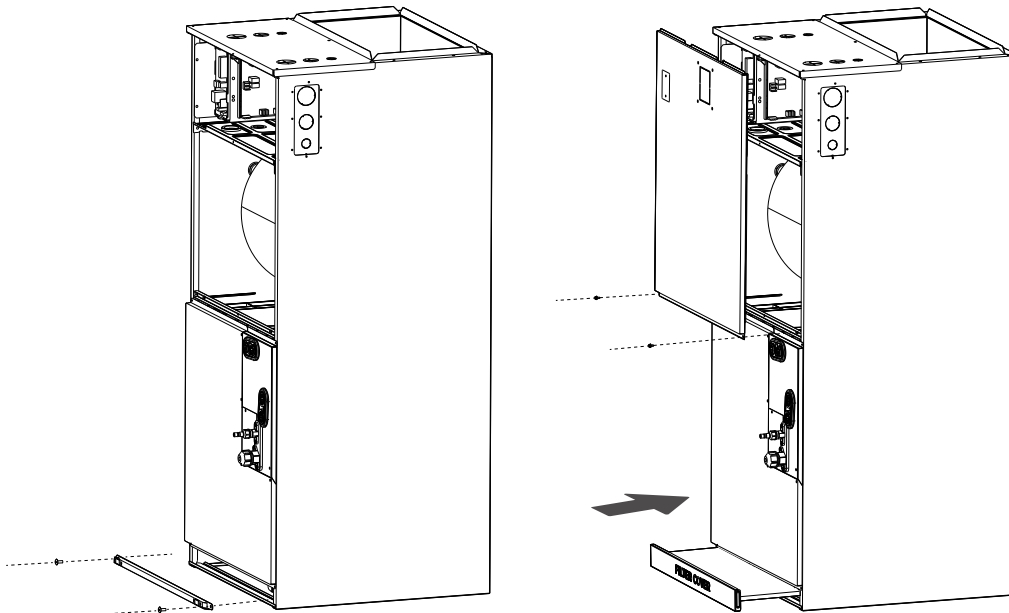

AIR HANDLER INSTALLATION

STEP 1: CONSIDER DUCTWORK AND CONDENSATE PIPE INSTALLATION REQUIREMENTS.

STEP 2: CONNECT CONDENSATE PIPE AND REFRIGERANT PIPING.

STEP 3: IF INSTALLING AN OPTIONAL AUXILIARY ELECTRIC HEATER, REFER TO THE HEATER INSTALLATION SECTION FOR WIRING DIAGRAMS AND EXPLANATION.

STEP 4: INSTALL OPTIONAL DEVICES.

STEP 5: CHECK AIR FLOW AND PERFORM A TEST RUN.

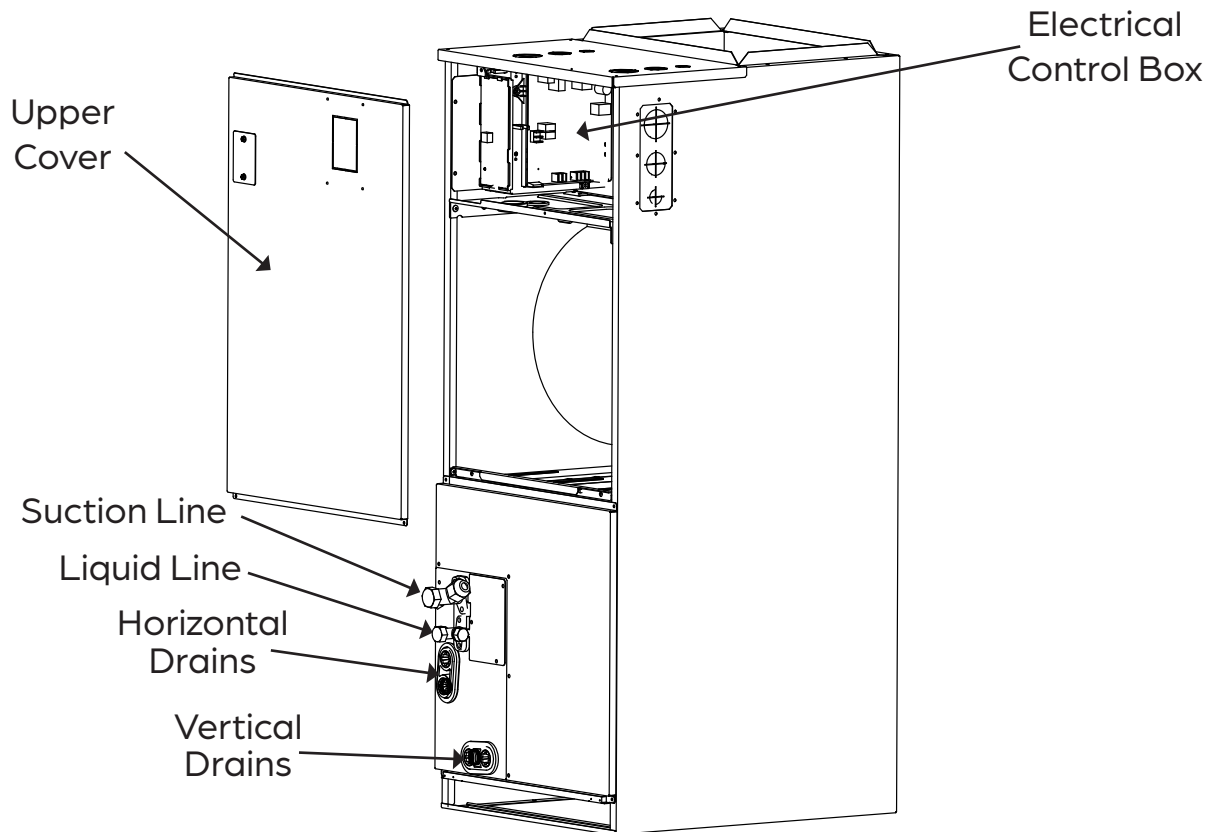

DUCT REQUIREMENTS

**NOTE**

This unit is not designed for non-ducted (free-blow) applications

- Air supply and return may be handled in one of several ways best suited to the installation (See unit dimensions for duct inlet and outlet dimensions). The vast majority of problems encountered with ducted systems can be linked to improperly designed or installed duct systems. It is critical for the function and longevity of the unit that the ductwork is correctly designed and installed.
- Use flexible duct collars to minimize the transmission of vibration/noise into the conditioned space.
- It is recommended to use lined return and supply duct near the unit when noise is a concern.
- The ductwork should be assembled according to the instructions.
- Wrap ductwork with insulation as specified by local codes, especially when installing in an unconditioned space. This will avoid condensation formation and building damage.
- The supply air duct connection should be properly sized by use of a transition to match the unit opening.
- All ducts should be suspended using flexible hangers and never fastened directly to the structure.

**WARNING**

Do not install this air handler or draw return air from where a gas-fueled appliance (i.e., water heater), or carbon monoxide-producing device (i.e., wood fireplace) is installed.

**WARNING**

There must be an airtight seal between the bottom of the air handler and the return air plenum. Use fiberglass sealing strips, foil duct tape, caulking, or an equivalent sealing method between the plenum and the air handler cabinet to ensure a tight seal.

CONDENSATE PIPING INSTALLATION

- Insulate all piping to prevent condensation, which could lead to water damage.
- The drainpipe is used to drain water away from the unit. If the drainpipe is bent or installed incorrectly, water may leak and cause a water-level switch malfunction.
- In HEAT mode, the outdoor unit will discharge water. Ensure that the drain hose is placed in an appropriate area to avoid water damage and icy conditions on walkways.
- DO NOT pull the drainpipe forcefully. This could disconnect it.
- Please apply sealant around the places where the wires, refrigerant pipes and condensate pipes enter the cabinet.
- Use duct tape or flexible sealant to seal closed any space around the holes where the drain lines exit the cabinet. Warm air must not be allowed to enter through any gaps or holes in the cabinet.
- After removal of drain pan plug(s), check drain hole(s) to verify that drain opening is fully open and free of any debris. Also check to make sure that no debris has fallen into the drain pan during installation that may plug up the drain opening.
- On units where the blower "draws" rather than "blows" air through the coil, traps must be installed in the condensate drain lines (primary and auxiliary, if used). Traps prevent the blower from drawing air through the drain lines into the air supply.

NOTE



A field-fabricated secondary drain pan, with a drain pipe to the outside of the building, is recommended in all installations over a finished living space or in any area that may be damaged by overflow from the main drain pan. The drain pan must be installed under the entire unit and its condensate drain line must be routed to a location such that the user will see the condensate discharge.

For horizontal installations, a secondary drain pan-not supplied-must be installed.

Drain Hole Location

The air handler has a primary and overflow drain hole for both vertical and horizontal installations. Make sure the factory installed seal plugs are tight when drains are not in use. Incorrect installation could result in leaks and flooding. See drain hole positions below.

Vertical Installation

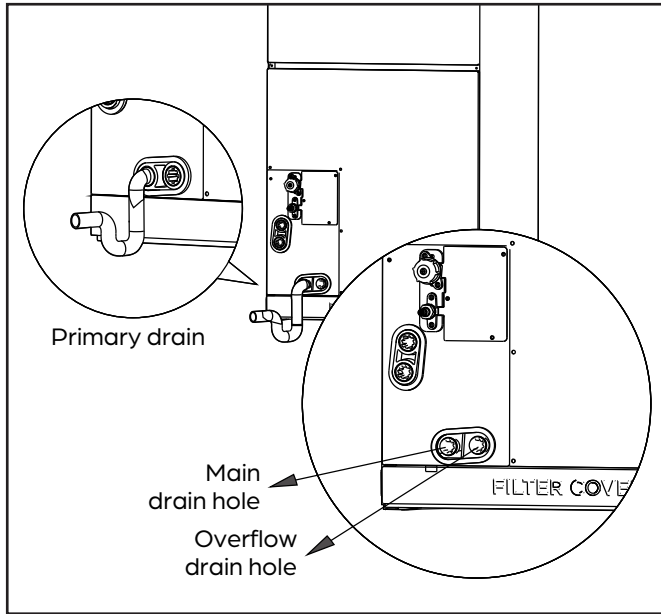

Horizontal Installation

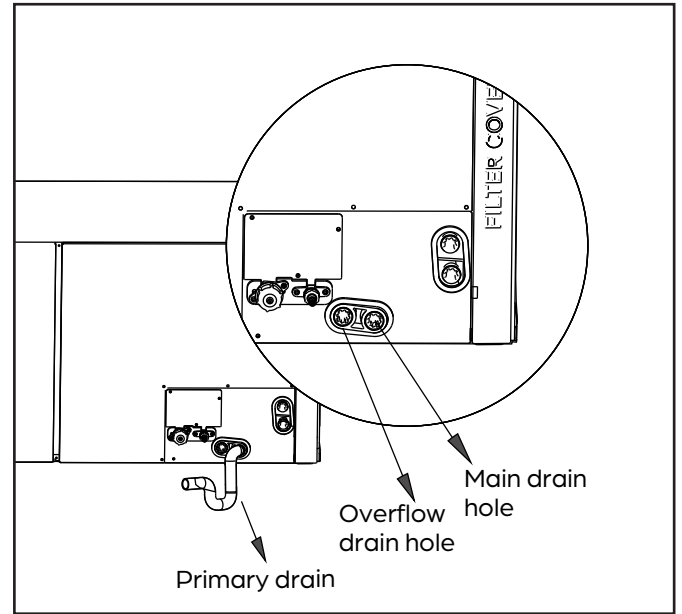

Drain Trap Format

These units operate with a negative pressure at the drain connections and a drain trap is required. The trap needs to be installed as close to the unit as possible. Make sure the top of the trap is below the connection to the drain pan to allow complete drainage of the pan.

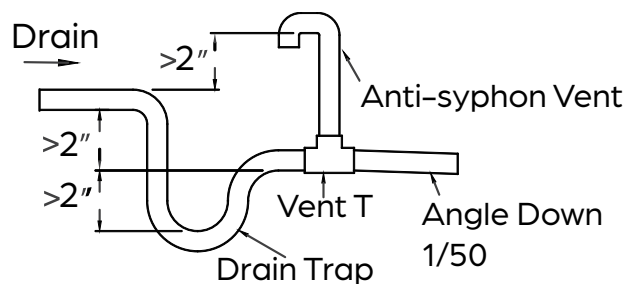

WARNING

The drainpipe outlet should be at least 1.9" above the ground or anticipated snowfall line. If it touches the ground, the drain may become blocked.

REFRIGERANT PIPING CONNECTION

All field piping must be completed by a licensed technician and must comply with the local and national regulations.

In the event of refrigerant leakage, measures should be taken to prevent the refrigerant concentration in the room from exceeding the safe limit. If the refrigerant leaks and its concentration exceeds its proper limit, hazards due to lack of oxygen may result. Ventilate the area immediately.



WARNING

When connecting refrigerant piping, do not let substances or moisture other than specified refrigerant enter the unit or pipes. Run nitrogen through the refrigerant tubing when brazing to avoid carbon build up. The presence of foreign materials will lower the unit's capacity and can cause abnormally high pressure in the refrigeration system. This can result in explosion and personal injury.

REFRIGERANT PIPE LENGTH

The length of refrigerant piping will affect the performance and efficiency of the unit. Nominal efficiency is tested with a pipe length of 25 feet (7.6 meters). A minimum pipe run of 10 feet (3 meters) is required to minimize vibration and excessive noise.

ADDING ADDITIONAL REFRIGERANT

Each outdoor unit is factory charged with enough refrigerant to support up to 25' (7.5m) per zone. This is based on a one way liquid line measurement from the outdoor unit to the indoor unit. Systems with line sets that exceed this length will require additional refrigerant (see the following chart). The refrigerant should be charged from the service port on the outdoor unit's low pressure valve. Additional refrigerant information can be found in the **SUBMITTAL DOCUMENTS** at **WWW.SERVICE.DURASTAR.COM**. Additional refrigerant can be calculated using the following chart and formula:

$$(\text{Actual pipe length} - \text{Standard pipe length}) \times \text{Additional Refrigerant Charge}$$

Refrigerant Piping Specifications

Capacity	Standard Refrigerant Connection Size	Standard Pipe Length w/ Precharged Refrigerant	Additional Refrigerant Charge		Maximum Length of Piping	Maximum Rise Length
			1/4 Liquid Line	3/8 Liquid Line		
	in (L x G)	ft (m)	oz/ft (g/m)	oz/ft (g/m)	ft (m)	ft (m)
18k	3/8 x 3/4	25 (7.6)	0.32 (30)	0.69 (65)	98.4 (30)	65.6 (20)
24k / 30k	3/8 x 3/4	25 (7.6)	0.32 (30)	0.69 (65)	164 (50)	82 (25)
36k / 42k / 48k / 60k	3/8 x 3/4	25 (7.6)	0.32 (30)	0.69 (65)	246 (75)	98.4 (30)



NOTE

Adapters are included with the indoor unit and outdoor unit to convert the flared fittings to brazed if necessary.



IMPORTANT NOTE:

The TOTAL SYSTEM CHARGE WEIGHT should be noted on the label adjacent to the unit rating label on the outdoor unit.

OIL TRAPS

Oil traps are necessary for the continued performance of the system if the indoor and outdoor units are installed at significantly different heights.



CAUTION

If oil flows back into the outdoor unit's compressor, this might cause liquid compression or deterioration of oil return. Oil traps in the rising gas piping can prevent this.

If the unit is **less than** 36000Btu/h an oil trap should be installed every 20ft (6m) of vertical suction line rise.

If the unit is **greater than** 36000Btu/h an oil trap should be installed every 32.8ft (10m) of vertical suction line rise.

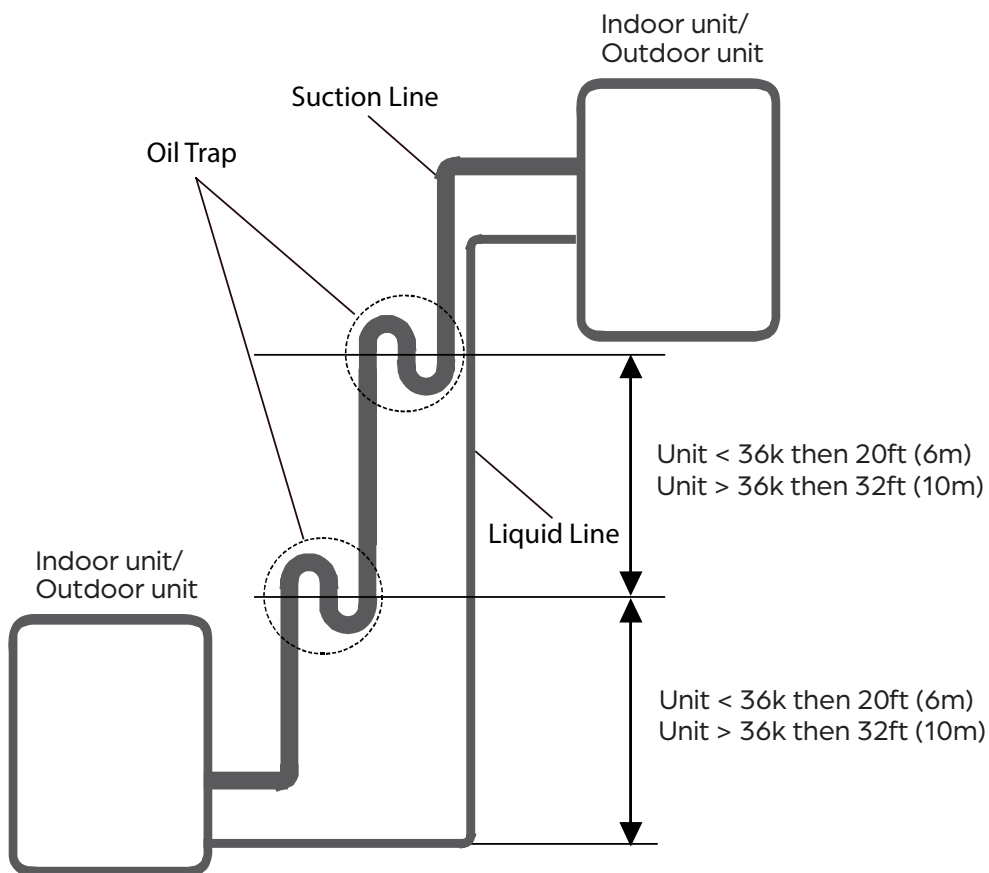

Refrigerant Pipe Connection Instructions

STEP 1: CUT PIPES

When preparing refrigerant pipes, take extra care to cut and flare them properly. This will ensure efficient operation and minimize leaks and the need for future maintenance.

1. Measure the distance between the indoor and outdoor units.
2. Using a pipe cutter, cut the pipe length a little longer than the measured distance.
3. Make sure that the pipe is cut at a perfect 90° angle.
4. Do not damage, deform, or dent the pipe while cutting.

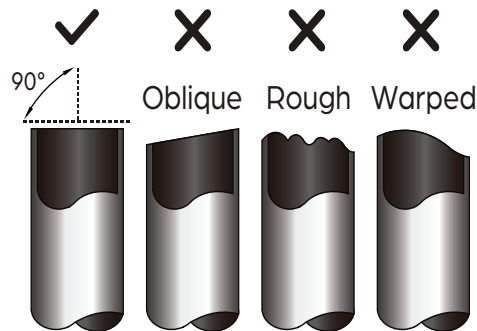

STEP 2: REMOVE BURRS

Burrs can affect the airtight seal of the refrigerant piping connection and must be completely removed.

1. Hold the pipe at a downward angle to prevent burrs from falling into the pipe.
2. Using a reamer or deburring tool, remove all burrs from the cut section of the pipe.

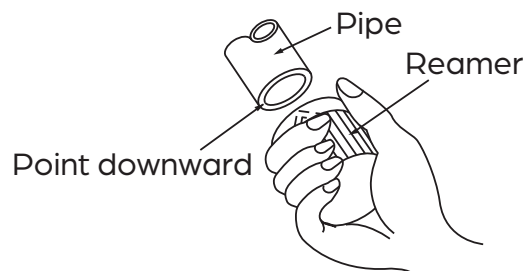

STEP 3: FLARE PIPE ENDS

Proper flaring is essential to achieve an airtight seal.

1. After removing burrs from cut pipe, seal the ends with PVC tape to prevent foreign materials from entering the pipe.
2. Sheath pipe with insulating material.
3. Place flare nuts on both ends of the pipe. Make sure they are facing in the right direction as you cannot change their orientation after flaring.

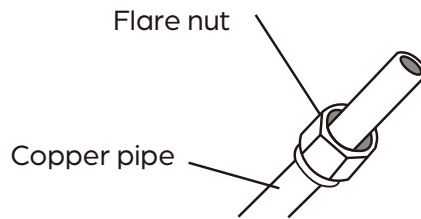

4. Remove PVC tape from ends of pipe when ready to perform flaring.
5. Clamp flare form on the end of pipe. The end of the pipe must extend beyond the edge of the flare form in accordance with the pipe extension table.

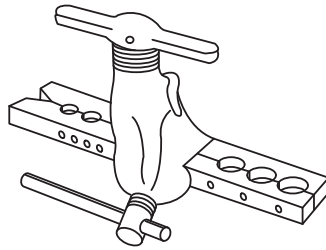

PIPE EXTENSION BEYOND FLARE FORM

Outer Diameter of Pipe Inches (mm)	"A" Minimum Extension Inches (mm)	"A" Maximum Extension Inches (mm)
Ø 3/8" (9.5mm)	0.04" (1.0mm)	0.063" (1.6mm)
Ø 5/8" (15.9mm)	0.078" (2.0mm)	0.086" (2.2mm)
Ø 3/4" (19.1mm)	0.078" (2.0mm)	0.094" (2.4mm)



WARNING

Do not use excessive torque. Excessive force can break the nut or damage the refrigerant piping. You must not exceed the torque requirements shown in the table above.

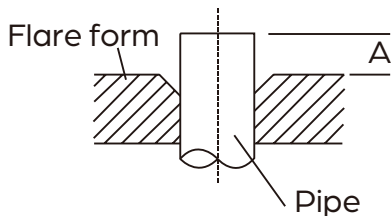

TIP: THICKNESS COMPARISON

- 0.0275" = A Thumbnail
- 0.04" = A Dime

6. Place flaring tool onto the form.
7. Turn the handle of the flaring tool clockwise until the pipe is fully flared.
8. Remove the flaring tool and flare form, then inspect the pipe for cracks and even flaring.

STEP 4: CONNECT PIPES

When connecting refrigerant pipes, be careful not to use excessive torque or to deform the piping in any way. You should first connect the low-pressure pipe, then the high-pressure pipe.

When bending connective refrigerant piping, the minimum bending radius is 4 inches (10cm). Do not leave coils in the refrigerant line sets. Remove excess line length to ensure proper system operation.

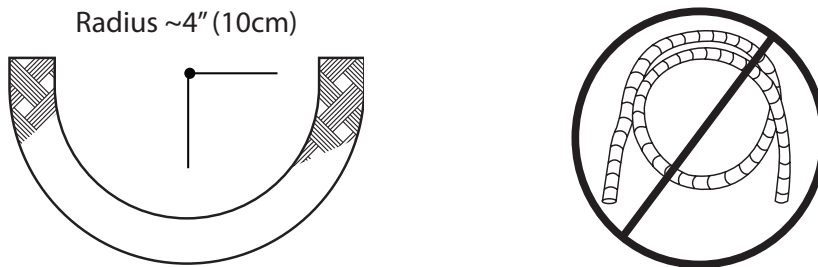

WARNING

Do not leave coils in the refrigerant line sets. All excess line length must be removed to ensure proper system operation.

Connecting Piping

1. Apply a thin coat of refrigerant oil on the flare part of the flare nut, but not the threads. If oil is applied to the threads the torque values can not be reached and the seal will leak.
2. Align the center of the two pipes that you will connect.

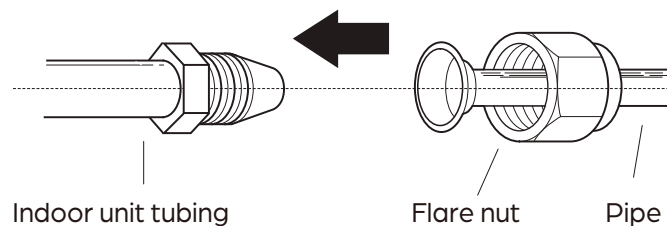

3. Tighten the flare nut as tightly as possible by hand.
4. Using a wrench, grip the nut on the unit tubing.

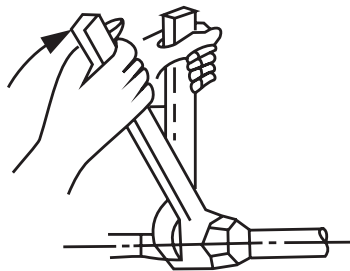

5. While firmly gripping the nut on the unit tubing, use a torque wrench to tighten the flare nut according to the torque values in the table in Step 3. Loosen the flaring nut slightly, then tighten again.

WIRING OVERVIEW



NOTE

The diagrams are for explanatory purposes only. Your unit may be slightly different.

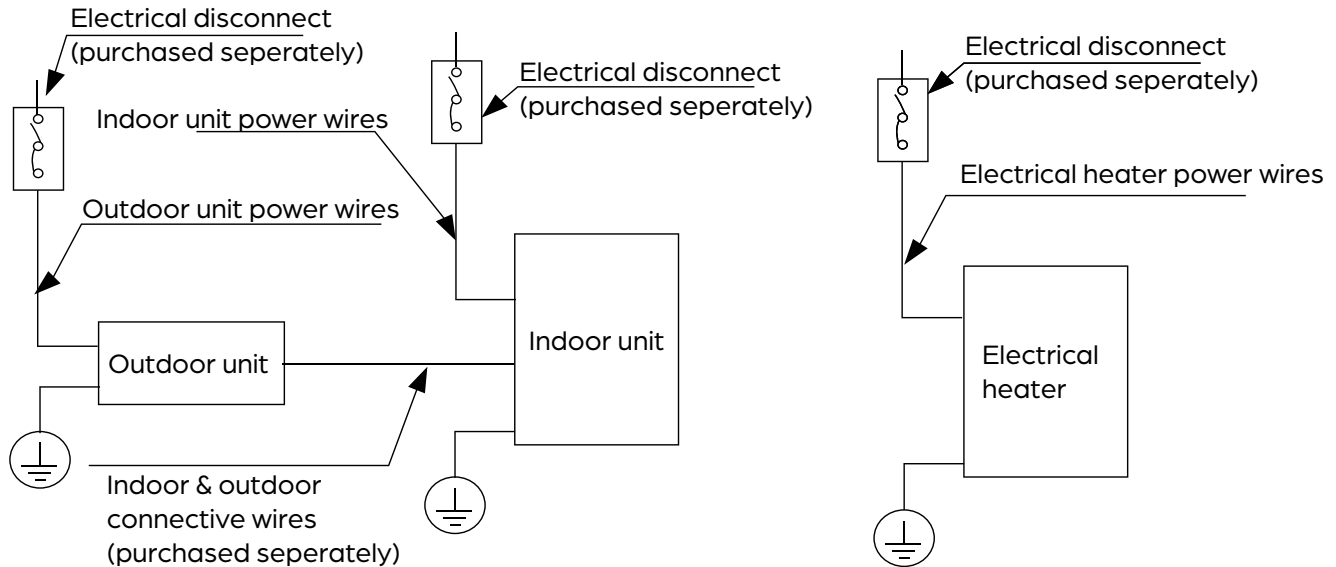

ELECTRIC HEATER INSTALLATION (OPTIONAL)

WARNING



- Installation must be performed by a licensed contractor. Use recommended PPE.
- Before installation, please confirm the electric auxiliary heat module and supplied accessories are complete and free of damage. Do not install if any items are damaged.
- Durastar factory approved heaters are UL rated with the equipment. DO NOT install a non-approved heater, this can cause damage and will not be covered under warranty.
- This heater is for installation in the air handler, DO NOT mount in the ductwork.

For installations requiring supplemental heating, the optional Electric Auxiliary Heat Module is available in sizes 3kW, 5kW, 8kW, 10kW, 15kW and 20kW to accommodate the specific heat load and electrical requirements of each installation. Please refer to the compatibility table below. Refer to **CONNECTION TYPE B** in the **ELECTRIC HEATER INSTALLATION MANUAL** included with the heater for installation instructions and electrical data.

AUXILIARY HEATER BTU COMPATIBILITY CHART

BTU SETTING	3kW	5kW	8kW	10kW	15kW	20kW
18K	Y	Y	Y	Y		
24K		Y	Y	Y	Y	
30K		Y	Y	Y	Y	
36K		Y	Y	Y	Y	
42-48K			Y	Y	Y	Y
60K				Y	Y	Y

INDOOR UNIT WIRING

**WARNING**

Failure to follow warnings may lead to equipment damage, injury or death. Field line side wires may remain live, DO NOT perform service or maintenance until the main disconnect is pulled.

**WARNING**

While connecting the wires, strictly follow the wiring diagram, and refer to the nameplate for electrical information. Wire according to NEC and local codes. The refrigerant circuit can become very hot. Keep the interconnection cable away from the copper tube.

ATTENTION: CONVERSION TO 115V IS NECESSARY (IF NEEDED)

This air handler is compatible with 115V power but it requires the conversion explained on page 40. Please follow these instructions carefully. If using 208/230V power, you can continue and disregard that section.

Connect the Signal Cable

The signal cable enables communication between the indoor and outdoor units. You must first choose the right cable size before preparing it for connection. Run a continuous length of cable and avoid splicing the cable.

Cable Sizing

Use the correct size cable depending on the communication type (see page 43)

- Non-polar RS485 Communication (S1/S2): 16 AWG to 20 AWG wire can be used. On new installations or if you experience communication interference, it is strongly recommended to use 16 AWG stranded, shielded wire for the best communication.
- 24V Communication: 18 AWG/ 8 conductor thermostat wire
- Power Cables: Determined by the minimum circuit ampacity (MCA) and maximum over current protection (MOCP) of system and the NEC and local codes in your area. Refer to the nameplate to choose the right cable, fuse, or switch.

STEP 1. PREPARE THE CABLE FOR CONNECTION.

- Using wire strippers, strip the insulating jacket from both ends of the signal cable to reveal about 5 in (12 cm) of the wire, then strip the insulation from the ends of the wires.

STEP 2. OPEN THE FRONT PANEL OF THE UNIT.

- Using a screwdriver, remove the cover of the electric control box on your indoor unit.

STEP 3. CONNECT THE WIRES TO THE TERMINALS.

- Thread the power cable and the signal cable through the wire outlet.
- Match the wire colors/labels with the labels on the terminal block. Firmly screw the wires of each wire to its corresponding terminal. Refer to the Serial Number and Wiring Diagram located on the cover of the electric control box.

115V POWER SUPPLY CONVERSION GUIDE



CAUTION

The motor has two pairs of plugs. If the white color plug is connected the motor is set to be powered by 208/230V (default); if the red color plug is connected the motor is set to be powered by 115V. When using a 208/230V power supply, the default white plug remains unchanged; When using a 115V power supply, the white motor plug needs to be removed and the red motor plug needs to be connected. When the motor is plugged into the red plug, the internal power supply must be 115V. If the unit is powered by a 208/230V power supply, the motor will be damaged.

STEP 1: Open the cover.

STEP 2: When using a 115V power supply, the fan motor wiring requires the use of the 115V fan motor plug. The 230V (white) fan motor pair plug needs to be removed and the 115V (red) fan motor pair plug needs to be connected.

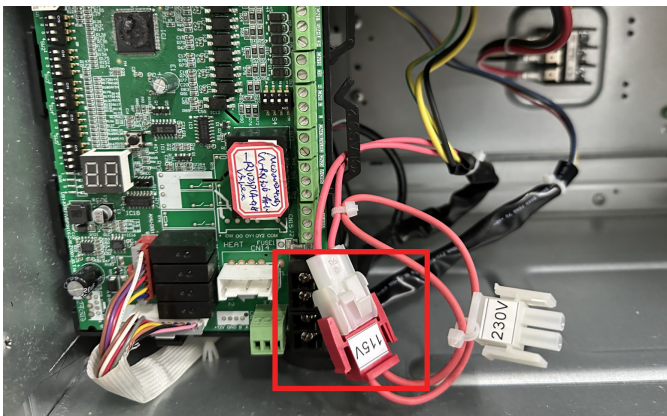
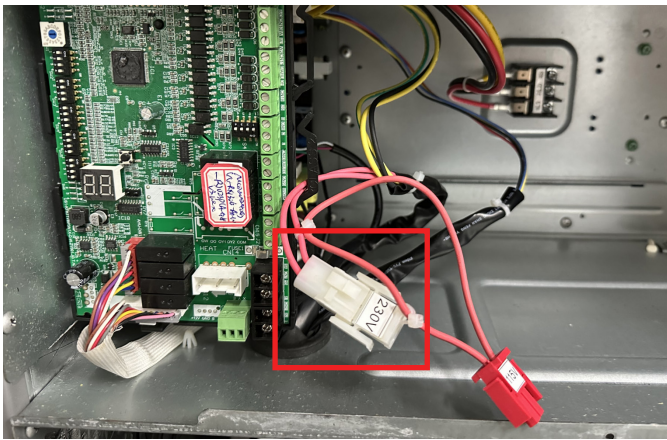

STEP 3: Unplug temperature sensors T1, T2, T2A, T2B, refrigerant detection sensor, electronic expansion valve (EEV), fan motor power pair plug (CN11) from the control board.

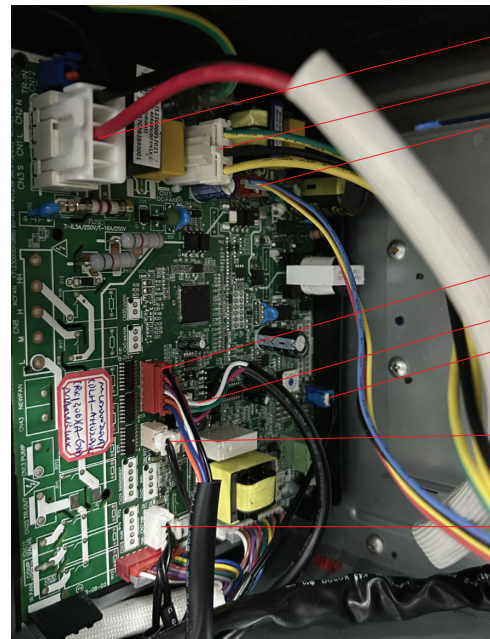

- CN11 (power wire)
- CN15 (fan motor)
- CN34 (fan motor)
- CN22 (EEV)
- CN26 (RDS)
- CN46 (T1 sensor)
- CN47 (T2 sensor)
- CN7 (T2A&T2B sensor)

STEP 4: Remove the two screws in the electric cabinet and take out the control assembly.

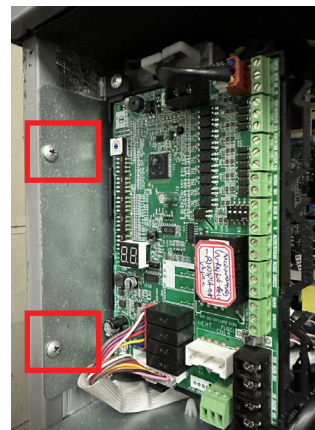

STEP 5: A connection wire is used to connect the 24V transformer to the main control board. Remove the blue plug from the control board CN12. Remove the red plug from the 24V transformer.



Back View

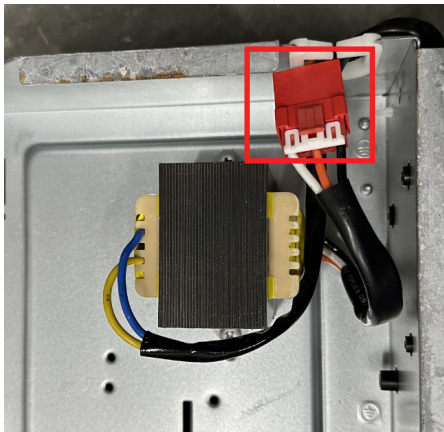

Top View (Remove the wire with the red connection)

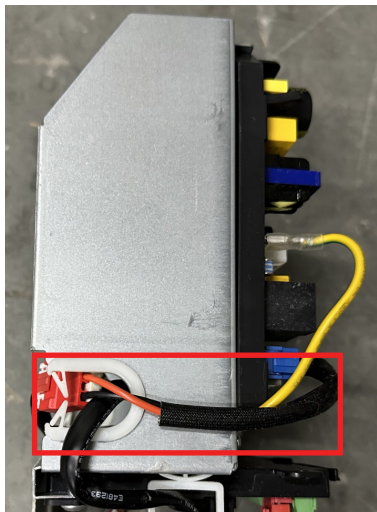

STEP 6: Take the 24V transformer connection wire (with the white plug) out from the accessory package. Connect the white connector to the red 24V transformer plug and the blue connector to the control board CN12.

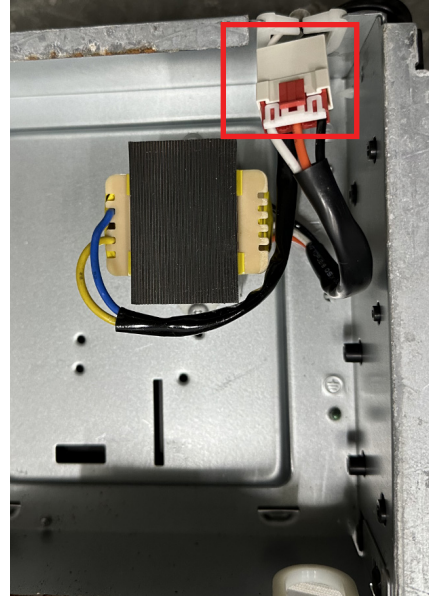

STEP 7: Replace the electronic control box and replace the screws. Replace the plugs as shown in the image below Step 3.



WARNING

WHEN USING A 115V POWER SUPPLY, L2 is N. Power the heater separately with 208/230V.



CAUTION

Isolate the power supply leads from the communication wire leads by using different knockouts in the cabinet and/or zip ties.

Wiring Indoor Without Heater

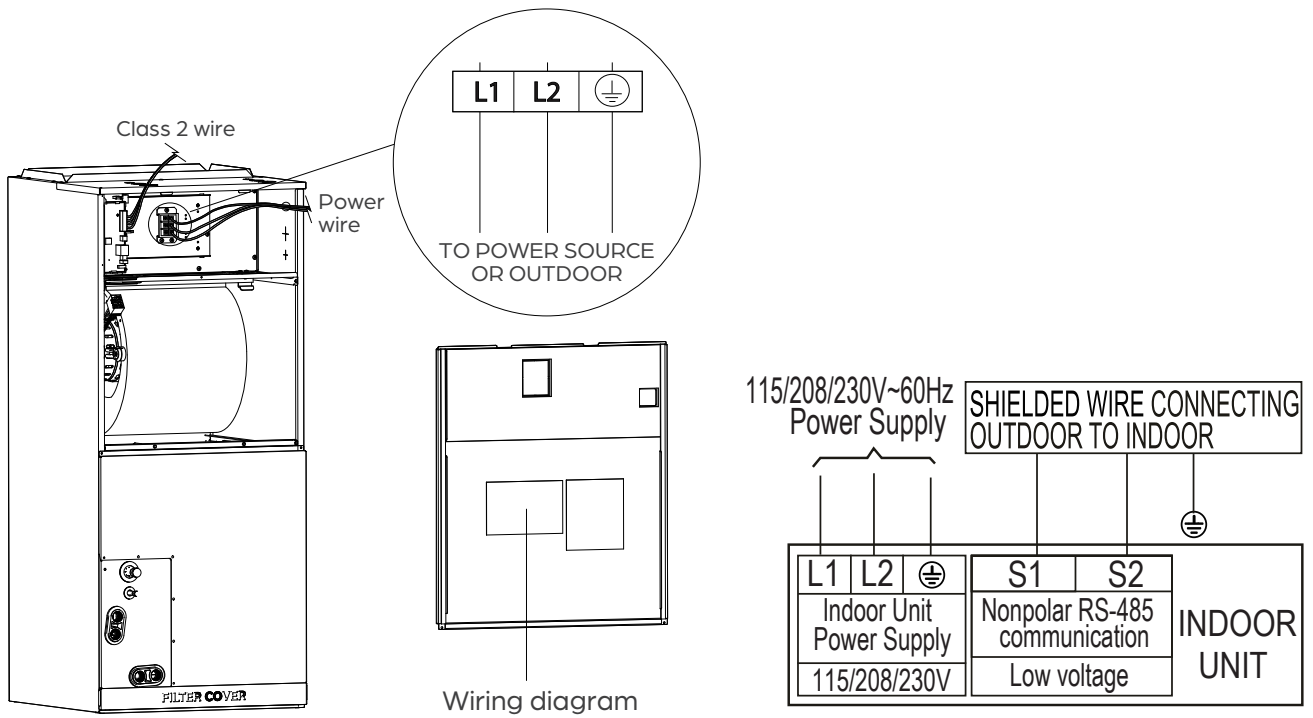

WARNING

TURN OFF POWER BEFORE ADJUSTING DIP SWITCHES.

Wiring the Communication Cable

The air handler ships with DIP SWITCH SW1 defaulted to off as seen below. Under this setting, the system will AUTOMATICALLY detect which of the three connection methods on the following page has been used. In the event of unexpected failure, the SW1 can be switched according to connection methods 1, 2, and 3.

Default Indoor Unit SW1

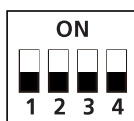

CAUTION

DO NOT connect 24VAC to the S1/S2 terminals. This will damage the system. Only connect to Class 2 terminals.

Wiring Methods



CAUTION

Please refer to the wiring nameplate for the wiring method.

Connection Method 1: RS485 Communication + 24V Thermostat

Use this method to connect a 24V thermostat while the indoor and outdoor are connected via RS485 communication. (In this method the auto ODU clean function is turned off, see page 55)

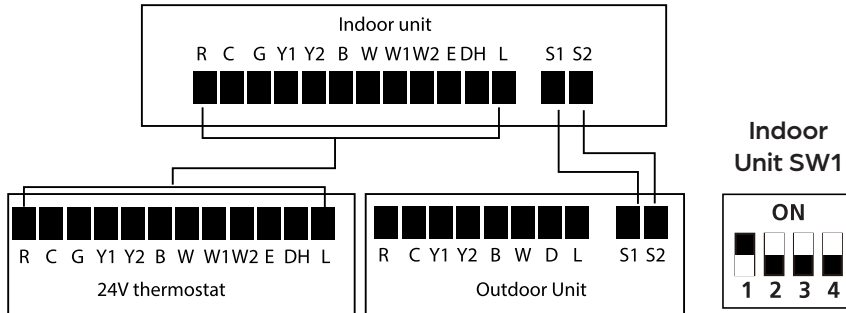

Connection Method 2: RS485 Communication

Use this connection method to connect the DRSTAT101 that is included with the air handler.

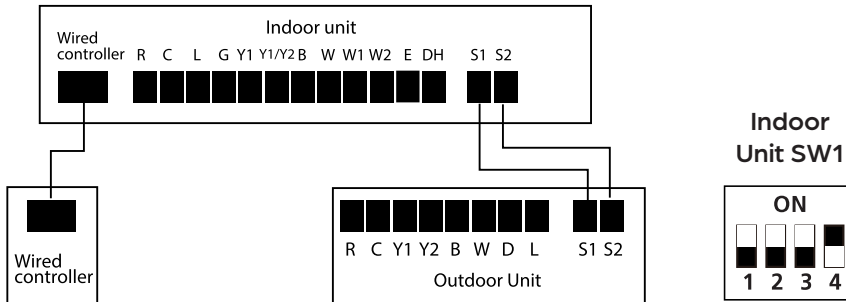

Connection Method 3: 24V Communication

This method does not comply with the DOE Controls Verification Procedure (10 CFR Part 429.134) effective 7/7/2026. AHRI rated systems must be installed using Method 1 or 2. Use this method for full 24V communication. Refer to 24V wiring methods on page 44 depending on your application. Note: SW1-2 must be flipped on at the outdoor unit.

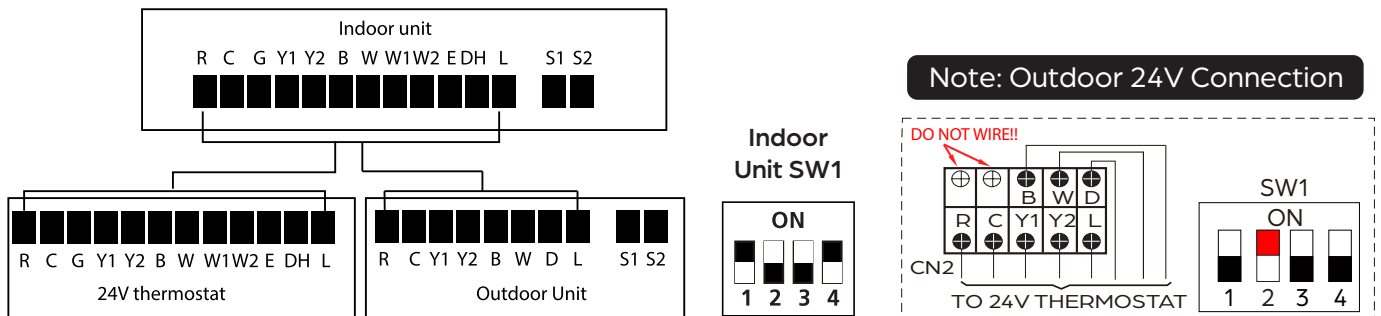

NOTE



For method 1 and 2, if there is a power failure or communication error, the compressor delays operating in heating mode for a period of 3 minutes after communication recovery.

NOTE



The "B" terminal energizes the reversing valve on call for heat. Please ensure that thermostat configuration is set up for B functionality. Note: These methods are for use with a Durastar outdoor unit with 24V communication or with a third party air handler, cased coil, and gas furnace.

Wiring for 4H and 2C Thermostat

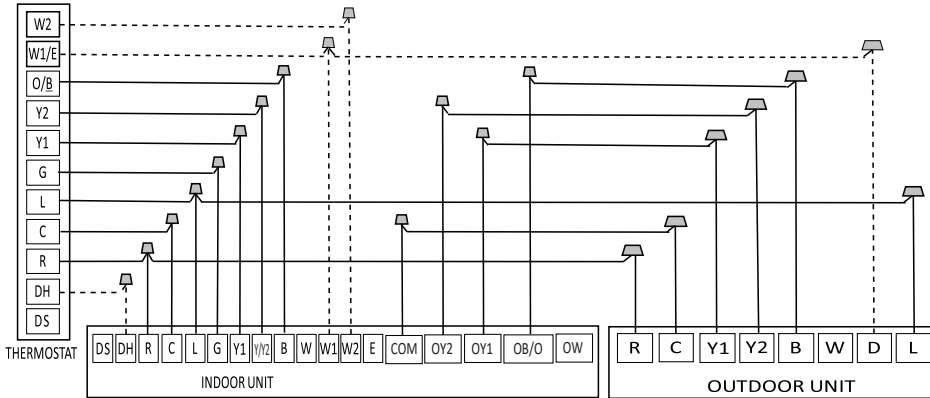

S4-2 Default on, DH function off. Turn switch off to activate DH function.

S4-4 Default on, W1 and W2 shorted for single stage Aux heat operation. Turn off to separate stages.

Wiring for 3H and 2C Thermostat

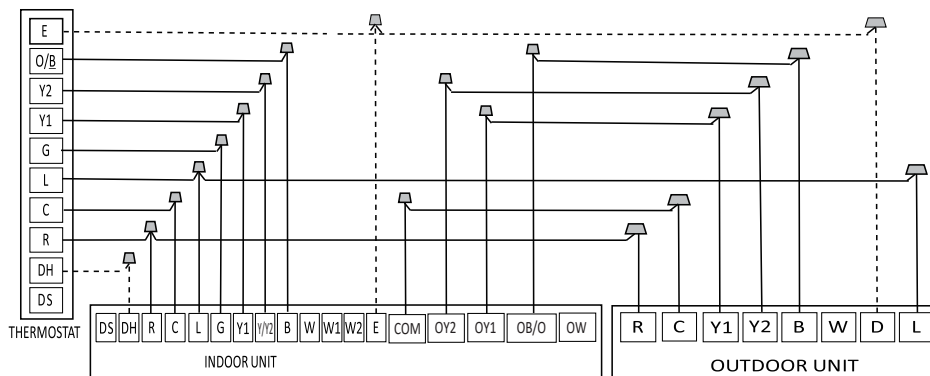

S4-2 Default on, DH function off. Turn switch off to activate DH function.

Emergency heating controls two groups of electric heating strips at the same time.

Wiring for 3H and 2C Thermostat

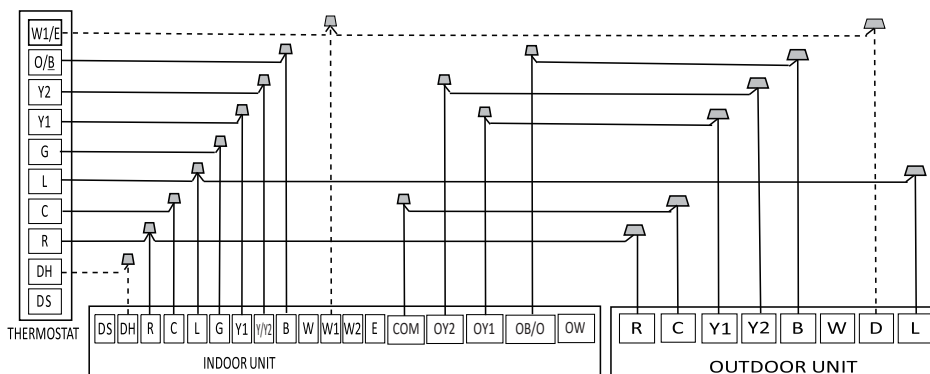

S4-2 Default on, DH function off. Turn switch off to activate DH function.

S4-4 Default on, W1 and W2 shorted for single stage Aux heat operation. Turn off to separate stages.

Wiring for 3H and 1C Thermostat

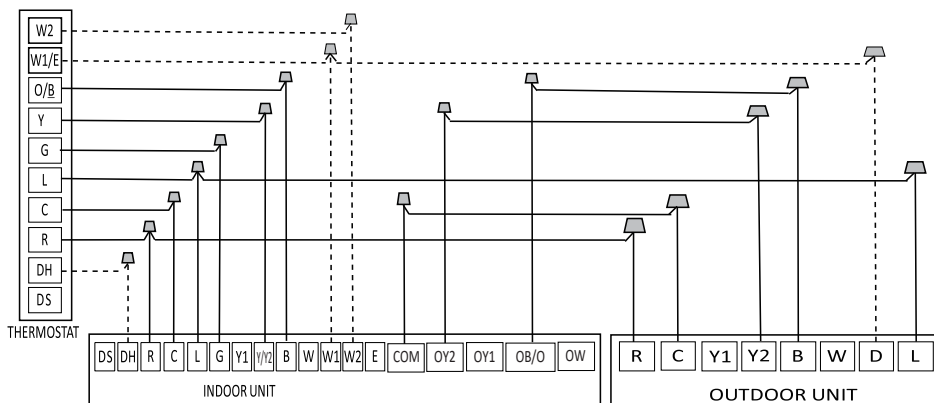

S4-2 Default on, DH function off.
Turn switch off to activate DH function.

S4-4 Default on, W1 and W2 shorted for single stage Aux heat operation. Turn off to separate stages.

Wiring for 2H and 2C Thermostat

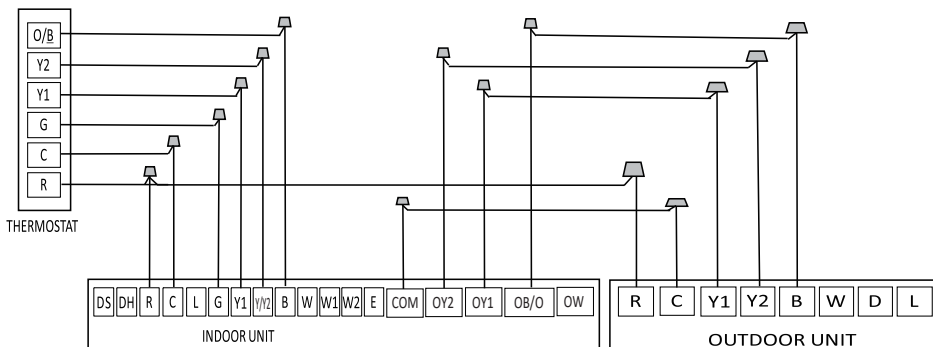

Wiring for 2H and 1C Thermostat

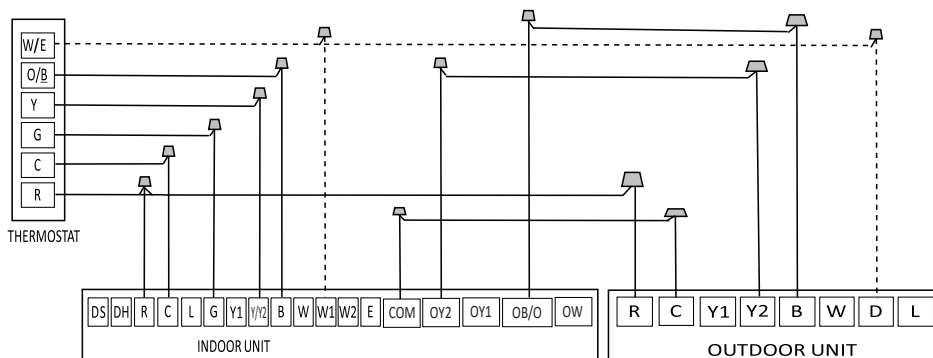

S4-4 Default on, W1 and W2 shorted for single stage Aux heat operation. Turn off to separate stages.

Wiring for 1H and 1C Thermostat (B Terminal)

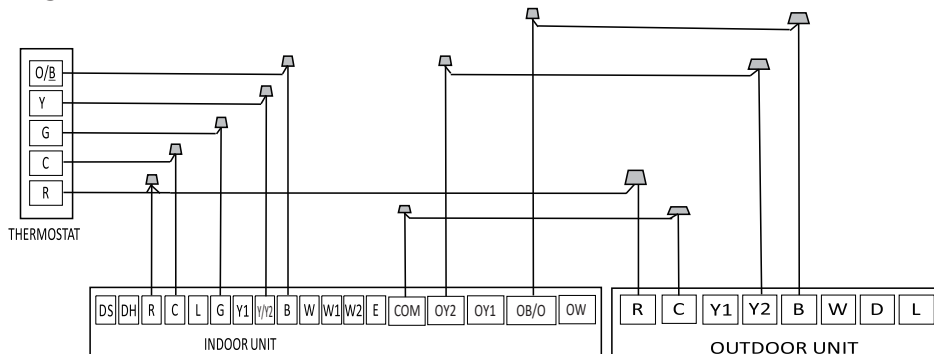

Wiring for 1H and 1C Thermostat (W Terminal)

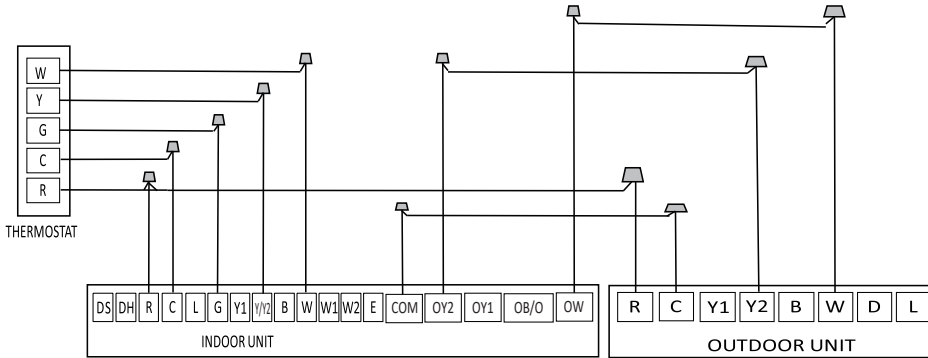

CONTROL LOGIC

Indoor Unit Connector

CONNECTOR	PURPOSE
R	24v Power Connection
C	Common
G	Fan Control
Y1	Low Cooling
Y/Y2	High Cooling
B	Heating Reversing Valve
W	Heating Control
W1	Stage 1 Electric Heating
W2	Stage 2 Electric Heating
E/AUX	Emergency Heating
DH/BK	Dehumidification/Zoning Control
DS	Reserved Signal
L	System Fault Signal

Outdoor Unit Connector

CONNECTOR	PURPOSE
R	24v Power Connection
C	Common
Y1	Low Cooling
Y2	High Cooling
B	Heating Reversing Valve
W	Heating Control
D	Defrost Control
L	System Fault Signal

AIR HANDLER POWER SPECIFICATIONS (without heater)



WARNING

While connecting the wires, strictly follow the wiring diagram, and refer to the nameplate for electrical information. Wire according to NEC and local codes.

Model Number	MCA 115V (A)	MCA 208/230V (A)	MOCP (A)	Motor Output (W)	RLA (A)
DRUM1824S2A	5.5	4.0	15	250	2 (18K) / 3 (24K)
DRUM3036S2A	8.0	6.0	15	375	4.5
DRUM4260S2A	14.5	11.0	15	750	7.8 (48K) / 8.3 (60K)

LED DISPLAY DEFINITIONS

The unit displays status as well as any active fault codes on the LED display. If the unit is functioning normally, the LED will display current temperature set-point. When a fault code is active, the display will flash quickly the active fault code. Please refer to the fault code table located in the troubleshooting section of the manual for detailed fault code information.

MODE	PRIORITY	G	Y1	Y/ Y2	B	W	W1	W2	E/ AUX	DH/ DS/BK	FAN SPEED	DISPLAY
OFF	/	0	0	0	0	0	0	0	0	*	OFF	0
FAN	7	1	0	0	*	0	0	0	0	*	Low	1
Cooling Stage 1	6	*	1	0	0	0	0	0	0	1	Mid	2
Cooling Stage 2		*	*	1	0	0	0	0	0	1	High	3
Dehumidification 1		*	1	0	0	0	0	0	0	0	Low	4
Dehumidification 2		*	*	1	0	0	0	0	0	0	Low	5
Heat Pump Stage 1	5	*	1	0	1	0	0	0	0	*	Mid	6
Heat Pump Stage 2		*	*	1	1	0	0	0	0	*	High	
Heat Pump Stage 2		*	*	*	*	1	0	0	0	*	High	7
Electric Heater Kit 1	3	*	0	0	*	0	1	0	0	*	Turbo	8
Electric Heater Kit 2		*	0	0	*	0	0	1	0	*	Turbo	
Electric Heater Kit 1 and Kit 2		*	0	0	*	0	1	1	0	*	Turbo	9
Heat Pump Stage 1 + Electric Heater Kit 1	4	*	1	0	1	0	1	0	0	*	Turbo	10
Heat Pump Stage 1 + Electric Heater Kit 2		*	1	0	1	0	0	1	0	*	Turbo	
Heat Pump Stage 2 + Electric Heater Kit 1		*	*	1	1	0	1	0	0	*	Turbo	
Heat Pump Stage 2 + Electric Heater Kit 1		*	*	*	*	1	1	0	0	*	Turbo	
Heat Pump Stage 2 + Electric Heater Kit 2		*	*	1	1	0	0	1	0	*	Turbo	
Heat Pump Stage 2 + Electric Heater Kit 2		*	*	*	*	1	0	1	0	*	Turbo	
Heat Pump Stage 1 + Electric Heater Kit 1 and Kit 2		*	1	0	1	0	1	1	0	*	Turbo	11
Heat Pump Stage 2 + Electric Heater Kit 1 and Kit 2		*	*	1	1	0	1	1	0	*	Turbo	
Heat Pump Stage 2 + Electric Heater Kit 1 and Kit 2		*	*	*	*	1	1	1	0	*	Turbo	
Emergency Heat	1	*	*	*	*	*	*	*	1	*	Turbo	12

Note:

1 = 24V Signal

0 = No 24V Signal

The AHU will turn off if the 24V input cannot meet the table.

DIP SWITCH SETTINGS



CAUTION

Only certified service technicians should change dip switch settings. Incorrect dip switch settings cause malfunctions or harm the unit.



CAUTION

UNIT MUST BE POWERED OFF BEFORE ADJUSTING SWITCHES

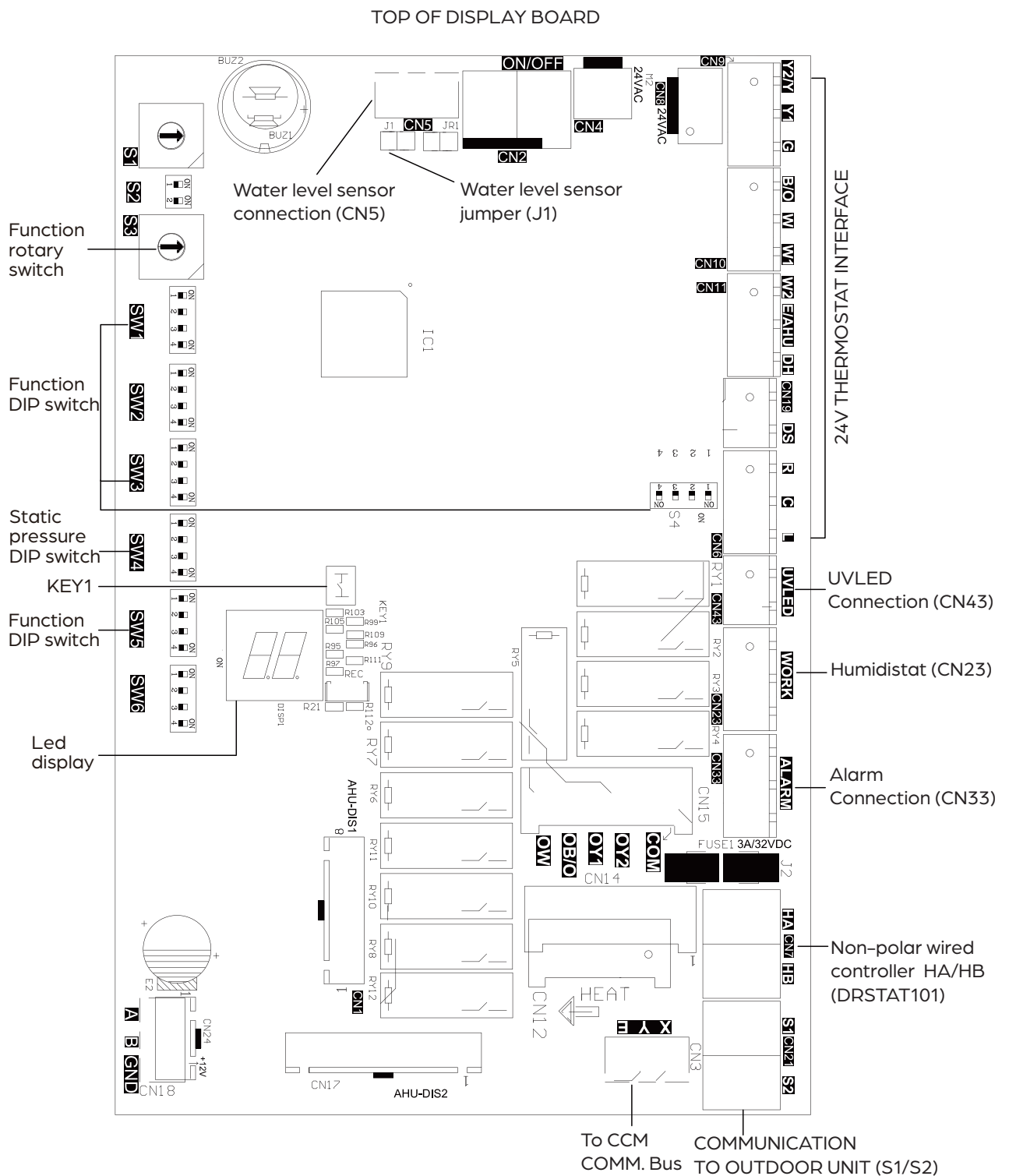

TOP OF MAIN CONTROL BOARD

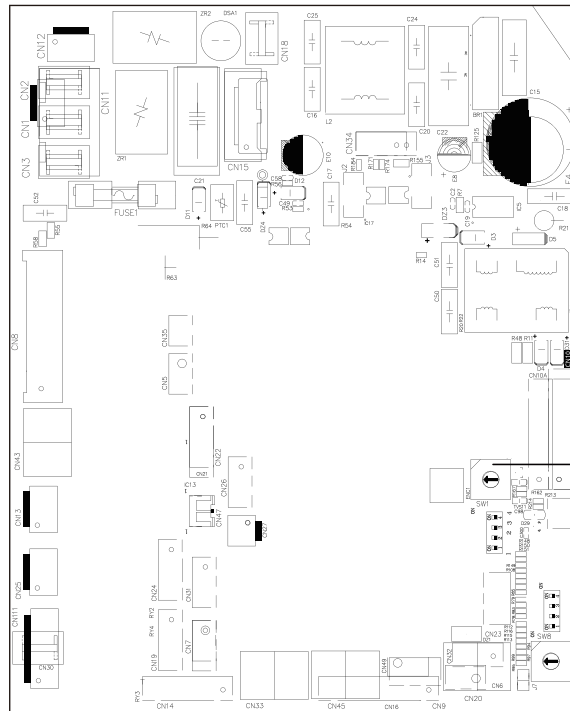

BTU selection rotary switch (ENC1)

Indoor Unit BTU Setting (rarely necessary)

When this DRUM Durastar air handler is paired with a DRU1 Durastar outdoor unit, the air handler will automatically determine which BTU it needs to be set at for proper operation. ENC1 rotary switch is set to "0" as default for this to happen. If the function does not work properly or if the air handler is paired with a third party unit. ENC1 can be adjusted per the chart below for BTU setting.

Indoor Unit Model	ENC1 Rotary Switch Settings					
	18K BTU	24K BTU	30K BTU	36K BTU	42K/48K BTU	60K BTU
DRUM1824S2A	5	8	N/A	N/A	N/A	N/A
DRUM3036S2A	N/A	N/A	9	A	N/A	N/A
DRUM4260S2A	N/A	N/A	N/A	N/A	C	E

Control Scenarios

Use the following two charts to make dip switch changes based on the chosen control scenario.

Control Scenario	24V Tstat, S1+S2	1
	DRSTAT101 Wired Controller, S1+S2	2
	Full 24V	3

DIP SWITCH DEFINITIONS

DIP SWITCH	CONTROL SCENARIO	FUNCTION	ON	OFF	NOTE
SW1-2	1,2,3	Anti-cold blow protection	NO	[Default] YES	
SW1-3	1,2,3	Single cooling / heating and cooling options	Cooling	[Default] Cooling & Heating	
SW2-1	1	Compressor Running (demand working with heat pump + Electric heat)	Compressor slower speed	[Default] Faster Compressor	Only affects W1 and compressor
SW2-1	2	Temperature differential to activate first stage auxiliary heat (the GAP of T1 and Ts), Wire controller demand with heat pump+Electric heat working together	2°F (1°C)	[Default] 4°F (2°C)	
SW2-2	2	Electric heat on delay	YES	[Default] NO	
SW2-3	2	Electric auxiliary heating delay to start time	30 minutes	[Default] 15 minutes	Based on SW2-2 is ON
SW2-4	1	Compressor	The operation of heat pump is limited by the outdoor temperature, and the operation of auxiliary heat is not limited. The system makes judgments according to the following rules: 1) The compressor can be operated when the outdoor temperature is \geq S3 DIP switch temperature + 4°F (2°C). 2) The compressor cannot be operated when the outdoor temperature is lower than the S3 DIP switch temperature.	[Default]The operation of heat pump is limited by the outdoor temperature, and the operation of auxiliary heat is not limited. The system makes judgments based on the following rules: 1) The compressor cannot be operated when the outdoor temperature is lower than the S3 DIP switch. 2) The compressor can be operated when the outdoor temperature is \geq S3 DIP switch temperature + 4°F (2°C).	SW2-4 and S3 need to working together
SW2-4	2	Compressor/Auxiliary heat outdoor ambient lockout	The operation of heat pump is limited by the outdoor temperature, and the operation of auxiliary heat is not limited. The system makes judgments according to the following rules: 1) The compressor can be operated when the outdoor temperature is \geq S3 DIP switch temperature + 4°F (2°C). 2) The compressor cannot be operated when the outdoor temperature is lower than the S3 DIP switch temperature.	[Default] Only one heat pump or auxiliary heat can be operated .The system makes judgments according to the following rules: 1) When the outdoor temperature is lower than the S3 DIP switch temperature, the compressor is not allowed to operated, but auxiliary heat is allowed to operated ; 2) When the outdoor temperature is \geq S3 DIP switch temperature + 4°F (2°C), the compressor can be operated, but auxiliary heat cannot be operated.	
Rotary Switch S3	1,2	Set outdoor temperature limitation (for auxiliary heating or compressor)	See Rotary Switch Table on the next page.		
SW3-1	1	Maximum continuous runtime allowed before system automatically stages up capacity to satisfy set point. This adds 1 to 5°F to the user set point in the calculated control point to increase capacity and satisfy user set point	30 minutes	[Default] 90 minutes	
SW3-2	1	Cooling and heating Y/Y2 temperature differential adjustment.	Compressor slower speed	[Default] Faster Compressor	Only affects compressor
SW3-3	1	Compressor Running (demand working with heat pump + Electric heat)	Compressor slower speed	[Default] Faster Compressor	Only affects compressor and W2
SW3-3	2	Temperature differential to activate second stage auxiliary heating(the GAP of T1 and Ts) Wire controller demand with heat pump+Electric heat working together	4°F (2°C)	[Default] 6°F (3°C)	
SW3-4	1,3	Fan speed of cooling mode when 24V Thermostat is applied.	Turbo	High	
SW4-1 SW4-2 SW4-3	1,2,3	Electric heat nominal CFM adjustment	Available settings are 000/001/010/011. Each digit corresponds an individual switch position. For example [SW4-1 OFF, SW4-2 ON, SW4 -3 OFF] = 010		
SW4-4	2	Temperature differential to activate third stage auxiliary heating(the GAP of T1 and Ts) Wire controller demand with heat pump+ Electric heat working together	6°F(3°C)	[Default]8°F(4°C)	Only valid for product which has three stage auxiliary heating.

DIP SWITCH	CONTROL SCENARIO	FUNCTION	ON	OFF	NOTE
S4-4	1,3	Default ON	[Default] For single stage supplemental heat, W1 and W2 are connected	For dual stage supplemental heat, W1 and W2 are controlled independently.	
S4-2	1,3	DH function selection	[Default] Dehumidification control not available	Dehumidification feature is enabled through thermostat	
SW5-3	1,2,3	L or Alarm relay selection	L output 24V or alarm relay close only when refrigerant sensor fault or R454B refrigerant leakage be detected	[Default] L output 24V or alarm relay close when any fault be detected	
SW5-4	1,2,3	R output selection	R stops outputting 24V when R454B refrigerant leakage be detected	[Default] R keeps outputting 24V even when R454B refrigerant leakage be detected	

KEY1 Button

- Press KEY1 to enter the forced automatic mode, press KEY1 again to enter the forced cooling mode (LED displays FC), and press KEY1 again to shut down.
- Press and hold KEY1 under forced cooling mode (LED displays FC) for 5s to enter forced defrost mode.

Function DIP Switch Settings

S3 Rotary Switch

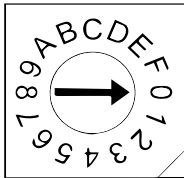

The S3 rotary switch is used to set the temperature protection between -22°F and 46°F . The switch defaults to OFF.

Rotary Switch Table

S3	S3 (°F)	S3 (°C)
0	OFF	OFF
1	-22	-30
2	-18	-28
3	-15	-26
4	-11	-24
5	-8	-22
6	-4	-20
7	3	-16
8	10	-12
9	18	-8
A	25	-4
B	32	0
C	36	2
D	39	4
E	43	6
F	46	8



NOTE

The SW4 DIP switch is only for certified service technicians to use.

When using a 24V thermostat, use the SW4 dip switch to set the proper air flow and heater settings.

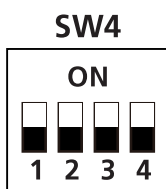

SW4-1	000 is the default Can be set as
SW4-2	000/001/010/ 011/100/101/110/111, for electric heating and PSC classification depending on the unit.
SW4-3	

AIR VOLUME TABLE

Capacity	External Static Pressure Range	Fan speed	Electric auxiliary heat module	24V Thermostat		Wired controller		Airflow volume (CFM)
				DIP Switch	24V terminal engaged	DIP Switch	Mode	
18K(1.5 Ton)	0 - 0.80 in.wc.	Cooling Turbo	—	SW3-4=ON	Y2/Y	—	Cool	618
		Cooling High	—	SW3-4=OFF	Y2/Y	—	Cool	576
		Cooling Medium	—	—	Y1	—	Cool	529
		Cooling Low	—	—	—	—	Cool	488
		Heat Pump Turbo	—	—	—	—	Heat	565
		Heat Pump High	—	—	B+Y2/Y,W	—	Heat	541
		Heat Pump Medium	—	—	Y1	—	Heat	435
		Heat Pump Low	—	—	—	—	Heat	400
		Electric auxiliary heat module 0(Default)	10kW	SW4-1=OFF SW4-2=OFF SW4-3=OFF	W1, W2, AUX	SW4-1=OFF SW4-2=OFF SW4-3=OFF	Heat + AUX, AUX	653
		Electric auxiliary heat module 1	10kW, 8kW	SW4-1=OFF SW4-2=OFF SW4-3=ON	W1, W2, AUX	SW4-1=OFF SW4-2=OFF SW4-3=ON	Heat + AUX, AUX	624
		Electric auxiliary heat module 2	8kW	SW4-1=OFF SW4-2=ON SW4-3=OFF	W1, W2, AUX	SW4-1=OFF SW4-2=ON SW4-3=OFF	Heat + AUX, AUX	594
		Electric auxiliary heat module 3	5kW, 3kW	SW4-1=OFF SW4-2=ON SW4-3=ON	W1, W2, AUX	SW4-1=OFF SW4-2=ON SW4-3=ON	Heat + AUX, AUX	565
24K(2 Ton)	0 - 0.80 in.wc.	Cooling Turbo	—	SW3-4=ON	Y2/Y	—	Cool	824
		Cooling High	—	SW3-4=OFF	Y2/Y	—	Cool	759
		Cooling Medium	—	—	Y1	—	Cool	694
		Cooling Low	—	—	—	—	Cool	629
		Heat Pump Turbo	—	—	—	—	Heat	788
		Heat Pump High	—	—	B+Y2/Y,W	—	Heat	753
		Heat Pump Medium	—	—	Y1	—	Heat	641
		Heat Pump Low	—	—	—	—	Heat	524
		Electric auxiliary heat module 0(Default)	15kW	SW4-1=OFF SW4-2=OFF SW4-3=OFF	W1, W2, AUX	SW4-1=OFF SW4-2=OFF SW4-3=OFF	Heat + AUX, AUX	871
		Electric auxiliary heat module 1	15kW, 10kW	SW4-1=OFF SW4-2=OFF SW4-3=ON	W1, W2, AUX	SW4-1=OFF SW4-2=OFF SW4-3=ON	Heat + AUX, AUX	841
		Electric auxiliary heat module 2	10kW, 8kW	SW4-1=OFF SW4-2=ON SW4-3=OFF	W1, W2, AUX	SW4-1=OFF SW4-2=ON SW4-3=OFF	Heat + AUX, AUX	818
		Electric auxiliary heat module 3	5kW	SW4-1=OFF SW4-2=ON SW4-3=ON	W1, W2, AUX	SW4-1=OFF SW4-2=ON SW4-3=ON	Heat + AUX, AUX	788
30K(2.5 Ton)	0 - 0.80 in.wc.	Cooling Turbo	—	SW3-4=ON	Y2/Y	—	Cool	988
		Cooling High	—	SW3-4=OFF	Y2/Y	—	Cool	894
		Cooling Medium	—	—	Y1	—	Cool	806
		Cooling Low	—	—	—	—	Cool	712
		Heat Pump Turbo	—	—	—	—	Heat	918
		Heat Pump High	—	—	B+Y2/Y,W	—	Heat	876
		Heat Pump Medium	—	—	Y1	—	Heat	665
		Heat Pump Low	—	—	—	—	Heat	453
		Electric auxiliary heat module 0(Default)	15kW	SW4-1=OFF SW4-2=OFF SW4-3=OFF	W1, W2, AUX	SW4-1=OFF SW4-2=OFF SW4-3=OFF	Heat + AUX, AUX	1088
		Electric auxiliary heat module 1	15kW, 10kW	SW4-1=OFF SW4-2=OFF SW4-3=ON	W1, W2, AUX	SW4-1=OFF SW4-2=OFF SW4-3=ON	Heat + AUX, AUX	1029
		Electric auxiliary heat module 2	10kW, 8kW	SW4-1=OFF SW4-2=ON SW4-3=OFF	W1, W2, AUX	SW4-1=OFF SW4-2=ON SW4-3=OFF	Heat + AUX, AUX	976
		Electric auxiliary heat module 3	5kW	SW4-1=OFF SW4-2=ON SW4-3=ON	W1, W2, AUX	SW4-1=OFF SW4-2=ON SW4-3=ON	Heat + AUX, AUX	918

Capacity	External Static Pressure Range	Fan Speed	Electric auxiliary heat module	24V thermostat		Wired controller		Airflow volume (CFM)
				DIP Switch	24V terminal engaged	DIP Switch	Mode	
36K (3 Ton)	0 - 0.80 in.wc.	Cooling Turbo	—	SW3-4=ON	Y2/Y	—	Cool	1188
		Cooling High	—	SW3-4=OFF	Y2/Y	—	Cool	1082
		Cooling Medium	—	—	Y1	—	Cool	971
		Cooling Low	—	—	—	—	Cool	865
		Heat Pump Turbo	—	—	—	—	Heat	1112
		Heat Pump High	—	—	B+Y2/Y, W	—	Heat	1059
		Heat Pump Medium	—	—	Y1	—	Heat	794
		Heat Pump Low	—	—	—	—	Heat	582
		Electric auxiliary heat module 0(Default)	20kW	SW4-1=OFF SW4-2=OFF SW4-3=OFF	W1, W2, AUX	SW4-1=OFF SW4-2=OFF SW4-3=OFF	Heat + AUX, AUX	1306
		Electric auxiliary heat module 1	15kW	SW4-1=OFF SW4-2=OFF SW4-3=ON	W1, W2, AUX	SW4-1=OFF SW4-2=OFF SW4-3=ON	Heat + AUX, AUX	1241
		Electric auxiliary heat module 2	10kW, 8kW	SW4-1=OFF SW4-2=ON SW4-3=OFF	W1, W2, AUX	SW4-1=OFF SW4-2=ON SW4-3=OFF	Heat + AUX, AUX	1176
Electric auxiliary heat module 3	5kW, 8kW	SW4-1=OFF SW4-2=ON SW4-3=ON	W1, W2, AUX	SW4-1=OFF SW4-2=ON SW4-3=ON	Heat + AUX, AUX	1112		
42K-48K (3.5-4 Ton)	0 - 0.80 in.wc.	Cooling Turbo	—	SW3-4=ON	Y2/Y	—	Cool	1600
		Cooling High	—	SW3-4=OFF	Y2/Y	—	Cool	1471
		Cooling Medium	—	—	Y1	—	Cool	1282
		Cooling Low	—	—	—	—	Cool	1094
		Heat Pump Turbo	—	—	—	—	Heat	1471
		Heat Pump High	—	—	B+Y2/Y, W	—	Heat	1324
		Heat Pump Medium	—	—	Y1	—	Heat	1141
		Heat Pump Low	—	—	—	—	Heat	976
		Electric auxiliary heat module 0(Default)	20kW	SW4-1=OFF SW4-2=OFF SW4-3=OFF	W1, W2, AUX	SW4-1=OFF SW4-2=OFF SW4-3=OFF	Heat + AUX, AUX	1741
		Electric auxiliary heat module 1	15kW	SW4-1=OFF SW4-2=OFF SW4-3=ON	W1, W2, AUX	SW4-1=OFF SW4-2=OFF SW4-3=ON	Heat + AUX, AUX	1653
		Electric auxiliary heat module 2	10kW, 8kW	SW4-1=OFF SW4-2=ON SW4-3=OFF	W1, W2, AUX	SW4-1=OFF SW4-2=ON SW4-3=OFF	Heat + AUX, AUX	1559
Electric auxiliary heat module 3	8kW	SW4-1=OFF SW4-2=ON SW4-3=ON	W1, W2, AUX	SW4-1=OFF SW4-2=ON SW4-3=ON	Heat + AUX, AUX	1471		
60K (5 Ton)	0 - 0.80 in.wc.	Cooling Turbo	—	SW3-4=ON	Y2/Y	—	Cool	1806
		Cooling High	—	SW3-4=OFF	Y2/Y	—	Cool	1582
		Cooling Medium	—	—	Y1	—	Cool	1359
		Cooling Low	—	—	—	—	Cool	1135
		Heat Pump Turbo	—	—	—	—	Heat	1659
		Heat Pump High	—	—	B+Y2/Y, W	—	Heat	1582
		Heat Pump Medium	—	—	Y1	—	Heat	1247
		Heat Pump Low	—	—	—	—	Heat	976
		Electric auxiliary heat module 0(Default)	25kW	SW4-1=OFF SW4-2=OFF SW4-3=OFF	W1, W2, AUX	SW4-1=OFF SW4-2=OFF SW4-3=OFF	Heat + AUX, AUX	2171
		Electric auxiliary heat module 1	15kW, 20kW	SW4-1=OFF SW4-2=OFF SW4-3=ON	W1, W2, AUX	SW4-1=OFF SW4-2=OFF SW4-3=ON	Heat + AUX, AUX	2029
		Electric auxiliary heat module 2	10kW, 15kW	SW4-1=OFF SW4-2=ON SW4-3=OFF	W1, W2, AUX	SW4-1=OFF SW4-2=ON SW4-3=OFF	Heat + AUX, AUX	1894
Electric auxiliary heat module 3	10kW	SW4-1=OFF SW4-2=ON SW4-3=ON	W1, W2, AUX	SW4-1=OFF SW4-2=ON SW4-3=ON	Heat + AUX, AUX	1753		

OPTIONAL FUNCTION WIRING

Condensate Overflow Switch:

The unit will accommodate a remote condensate overflow switch. To enable, remove jumper J1, and connect the installer provided condensate overflow device to CN5 per below. When an overflow condition is present, the device should open the connection, signaling the unit to turn off the system.

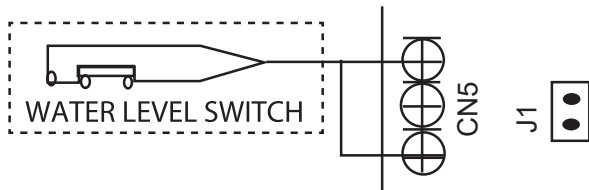

Alarm Output:

An alarm output (CN33) can be utilized if actions are required when a fault is present. This is a passive outlet port, so you will need to input a voltage signal. The relay is normally-open for normal operation, and closed when a fault condition is active.

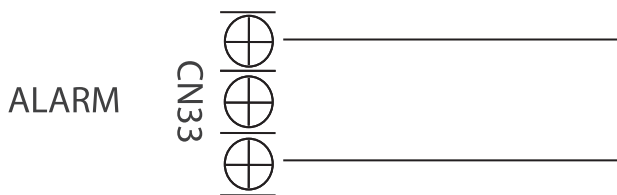

Humidifier Control:

To connect a humidifier, utilize the passive signal "WORK" output (CN23) port as well as the G and C wires on the controller, and wire the humidistat and humidifier per above wiring diagram. When the fan is running, the CN23 relay will be closed, which will allow power to the humidifier when the humidistat is below humidity setpoint. If the thermostat or zone controller has an HUM interface, connect the humidifier directly to the HUM and C ports.

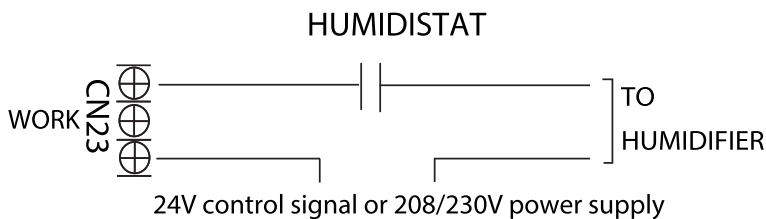

Dehumidification Control Wiring

Dehumidification control requires external Humidistat at DH and R. Set S4-2 as OFF. When the humidity rises and exceeds the set value of the Humidistat, the 24V signal of DH changes to 0V, the cooling system starts the dehumidification operation, and the air volume drops to 80% of the nominal cooling air volume.

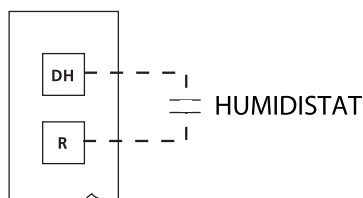

UV LED Wiring

The WORK port is linked with the fan. When the fan is running, the relay is closed; if an active 24V signal is required, it can be directly connected to the G and C ports.

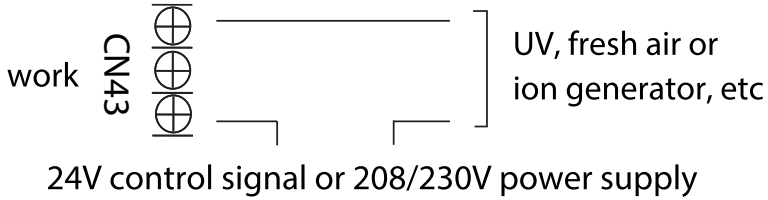

Outdoor Unit SW1 Dip Switch Setting

DIAL CODE	FEATURE	ON	OFF
SW1-1	N/A		
SW1-2	Communication type	24V communication between IDU only (no ODU clean function*)	RS485 communication with DRSTAT101 or 24V tstat
SW1-3	Stronger cooling and heating function	Increases compressor frequency. Cooling will decrease around 5.5°F (3°C) in Y2 and 3.5°F (2°C) in Y1. Heating will increase around 5.5°F (3°C).	The cooling/ heating target pressure compensation value is invalid.
SW1-4	Enhanced defrosting	Enhanced defrosting with a more frequent defrost cycle	Default setting (standard defrost algorithm)

*The outdoor unit clean function is an automatic function that reverses the outdoor fan to blow leaves and dust off of the coil fins. When the outdoor and indoor unit communicates via the 24V thermostat wire this setting is disabled.

FINAL CHECKS

**WARNING**

Failure to perform the test run may result in unit damage, property damage, or personal injury.

BEFORE THE TEST RUN

A test run must be performed after the entire system has been completely installed.

Confirm the following points before performing the test:

- Indoor and outdoor units are properly installed.
- Piping and wiring are properly connected.
- No obstacles near the inlet and outlet of the unit that might cause poor performance or product malfunction.
- Drainage system is unimpeded and draining to a safe location.
- Insulation of piping and duct is properly installed.
- Grounding wires are properly connected.
- Length of the piping and additional refrigerant capacity have been recorded.
- Power voltage is the correct voltage for the air handler.
- Electrical Safety Checks – Confirm that the unit's electrical system is connected and operating correctly.
- Gas Leak Check – Check all flare nut connections and confirm the system is not leaking.
- Confirm that the low and high pressure valves are fully open.
- Check grounding work by measuring the grounding resistance by visual detection and with a multimeter. The grounding resistance must be less than 0.1 Ω.

ELECTRICAL SAFETY CHECKS

After installation, confirm that all electrical wiring is installed in accordance with local and national regulations, and according to this installation manual.

DURING TEST RUN

Using your multimeter, verify the voltage of the main power entering the system. If the main power voltage is greater than ±10% of the name plate voltage, turn off the unit and immediately call a licensed electrician to find and resolve the cause.

**WARNING**

RISK OF ELECTRICAL SHOCK – All wiring must comply with local and national electrical codes, and must be installed by a licensed electrician.

GAS LEAK CHECK

There are two methods to check for gas leaks:

1. Soap and Water Method – Using a soft brush, apply a soapy water or liquid detergent to all pipe connection points on the indoor and outdoor unit. The presence of bubbles indicates a leak.
2. Leak Detector Method – If using a leak detector, refer to the device's operation manual for proper usage instructions.

GAS LEAK CHECK POINTS

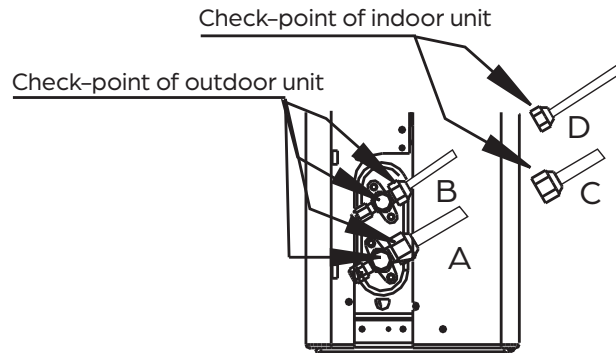

A: Low pressure stop valve
 B: High pressure stop valve
 C & D: Indoor unit flare nuts

TEST RUN

TEST RUN INSTRUCTIONS

You should perform the test run for at least 30 minutes.

1. Connect power to the unit.
2. Press the ON/OFF button on the remote controller or wired thermostat to turn the unit on.
3. Press the MODE button to scroll through the following functions, one at a time:
 - COOL – Select lowest possible temperature.
 - HEAT – Select highest possible temperature.
4. Let each function run for 5 minutes and perform the following checks:

LIST OF CHECKS TO PERFORM	[X]
Unit is Properly Grounded	[]
All Electrical Terminals are Properly Covered	[]
Indoor and Outdoor Units are Solidly Installed	[]
All Pipe Connection Points Do Not Leak	[]
Water Drains Properly from Drain Hose without leaks	[]
All Piping is Properly Insulated	[]
Unit Performs COOL Function Properly	[]
Unit Performs HEAT Function Properly	[]
There is no abnormal noise or vibration	[]
Indoor Unit Responds to Remote Controller or Thermostat	[]

5. Double check all pipe connections. During operation, the pressure of the refrigerant system will increase. This may reveal leaks that were not present during the initial leak check. Take time during the test run to recheck all pipe connection points. Refer to *Gas Leak Check* section for instructions.
6. Ensure the condensate flows smoothly through the drain. It may take up to one (1) minute before the unit begins to drain, depending on the drainpipe. In new buildings, this should be performed before finishing the ceiling.

TROUBLESHOOTING

SAFETY PRECAUTIONS

If ANY of the following conditions occur, turn off your unit immediately!

- The power cord is damaged or abnormally warm
- You smell a burning odor
- The unit emits loud or abnormal sounds
- A power fuse blows or the circuit breaker frequently trips
- Water or other objects fall into or out of the unit

DO NOT ATTEMPT TO FIX THESE YOURSELF! CONTACT AN AUTHORIZED SERVICE PROVIDER IMMEDIATELY!

COMMON ISSUES

The following problems are not malfunctions and in most situations do not require repairs.

ISSUE	POSSIBLE CAUSES
The unit changes from COOL/HEAT mode to FAN mode	The unit may change its setting to prevent frost from forming on the unit. Once the temperature increases, the unit will start operating in the previously selected mode again.
	The set temperature has been reached, at which point the unit turns off the compressor. The unit will continue operating when the temperature fluctuates again.
Unit does not turn on when pressing ON/OFF button	The unit has a 3-minute protection feature that prevents the unit from overloading. The unit cannot be restarted within three minutes of being turned off.
	Cooling and Heating Models: If the Operation light and PRE-DEF (Pre-heating/Defrost) indicators are lit up, the outdoor temperature is too cold and the unit's anti-cold wind is activated in order to defrost the unit.
	In Cooling-only Models: If the "Fan Only" indicator is lit up, the outdoor temperature is too cold and the unit's anti-freeze protection is activated in order to defrost the unit.
Outdoor units emit white mist	When the unit restarts in HEAT mode after defrosting, white mist may be emitted due to moisture generated during the defrosting process.
Both the indoor unit and outdoor unit make noises	Low hissing sound during operation: This is normal and is caused by refrigerant gas flowing through both indoor and outdoor units.
	Low hissing sound when the system starts, has just stopped running, or is defrosting: This noise is normal and is caused by the refrigerant gas stopping or changing direction.
	Squeaking sound: Normal expansion and contraction of plastic and metal parts caused by temperature changes during operation can cause squeaking noises.

ISSUE	POSSIBLE CAUSES
The outdoor unit makes noises	The unit will make different sounds based on its current operating mode.
The unit emits a bad odor	The unit may absorb odors from the environment (such as furniture, cooking, cigarettes, etc.) which will be emitted during operations.
	The unit's filters have become dirty and should be cleaned.
	During heating the unit may emit a bad odor. This is a result of the electric heat module (AUX) heating up and burning off small particles of dust from the cooling season. This smell will lessen after a few uses and go away when the AUX heat is off.
The fan of the outdoor unit does not operate	During operation, the fan speed is controlled to optimize product operation.
Operation is erratic, unpredictable, or unit is unresponsive	<p>In rare cases, interference from radio waves and remote boosters may cause the unit to malfunction. In this case, try the following:</p> <ul style="list-style-type: none"> • Disconnect the power, then reconnect. • Press ON/OFF button on remote control to restart operation.

NOTE

 If problem persists, contact a local dealer or your nearest customer service center. Provide them with a detailed description of the unit malfunction as well as your model number.

TROUBLESHOOTING cont.

If trouble occurs, please check the following points before contacting a repair company.

PROBLEM	POSSIBLE CAUSES	SOLUTION
Poor cooling performance	Temperature setting may be higher than ambient room temperature.	Lower the temperature setting.
	The heat exchanger coil on the indoor or outdoor unit is dirty.	Contact a servicer to clean the affected heat exchanger coil.
	The air filter is dirty.	Replace the air filter.
	The air inlet or outlet of either unit is blocked.	Turn the unit off, remove the obstruction and turn it back on.
	Doors and windows are open.	Make sure that all doors and windows are closed while operating the unit.
	Excessive heat is generated by sunlight.	Close windows and curtains during periods of high heat or bright sunshine.
	Too many sources of heat in the room (people, computers, electronics, etc.).	Reduce amount of heat sources.
	Return grille is blocked or diffuser vents are shut.	Make sure the return grille and diffusers are unrestricted.
Poor heating performance	The outdoor temperature is extremely low.	Use auxiliary heating device.
	Cold air is entering through doors and windows.	Make sure that all doors and windows are closed during use.
	The air filter is dirty.	Replace the air filter.
	Return grille is blocked or diffuser vents are shut.	Make sure the return grille and diffusers are unrestricted.
Indicator lamps continue flashing or error code appears	<p>The unit may stop operation or continue to run safely. If the indicator lamps continue to flash or error codes appear, wait for about 10 minutes. The problem may resolve itself.</p> <p>If not, turn off the unit, then turn it on again.</p> <p>If the problem persists, disconnect the power and contact your nearest customer service center.</p>	
The unit is not working	Power failure	Wait for the power to be restored
	Remote control batteries are dead	Replace the batteries
	The unit's 3-minute protection has been activated	Wait three minutes after restarting the unit
	Timer is activated	Turn timer off



NOTE

If your problem persists after performing the checks and diagnostics above, or an error code remains, turn off your unit immediately and contact an authorized service center.

WIRING DIAGRAMS

DRUM1824S2A

WIRING DIAGRAM

CODE	PART NAME
FAN1	INDOOR ECM MOTOR
T1	ROOM TEMP. SENSOR
T2	COIL TEMP. SENSOR
T2A	INDOOR COIL INLET TEMP. SENSOR
T2B	INDOOR COIL OUTLET TEMP. SENSOR

NOTE1:

1. This symbol indicates the element is optional the actual shape shall prevail.
2. Remove the short connector of JR1 when using the "ON-OFF" function.
3. Remove the short connector of J1 when using the "WATER LEVEL SWITCH" function.

FOR SETTING POWER(DC MOTOR MODEL ONLY)

ENC1	0	3	5	8	9	A	C	E
CAPACITY	AUTO	12K	18K	24K	30K	38K	48K	80K
FACTORY SETTING	ACCORDING TO RELATED MODEL							

FOR SETTING NET ADDRESS

S1+SW8	0	1	2	3	4	5	6	7	8	9
CODE	0~F	0~F	16~31	0~F	0~F	32~47	0~F	48~63	0~F	0~F
NET ADDRESS	0~15	16~31	32~47	48~63	0~F	0~F	0~F	0~F	0~F	0~F
FACTORY SETTING	ACCORDING TO RELATED MODEL									

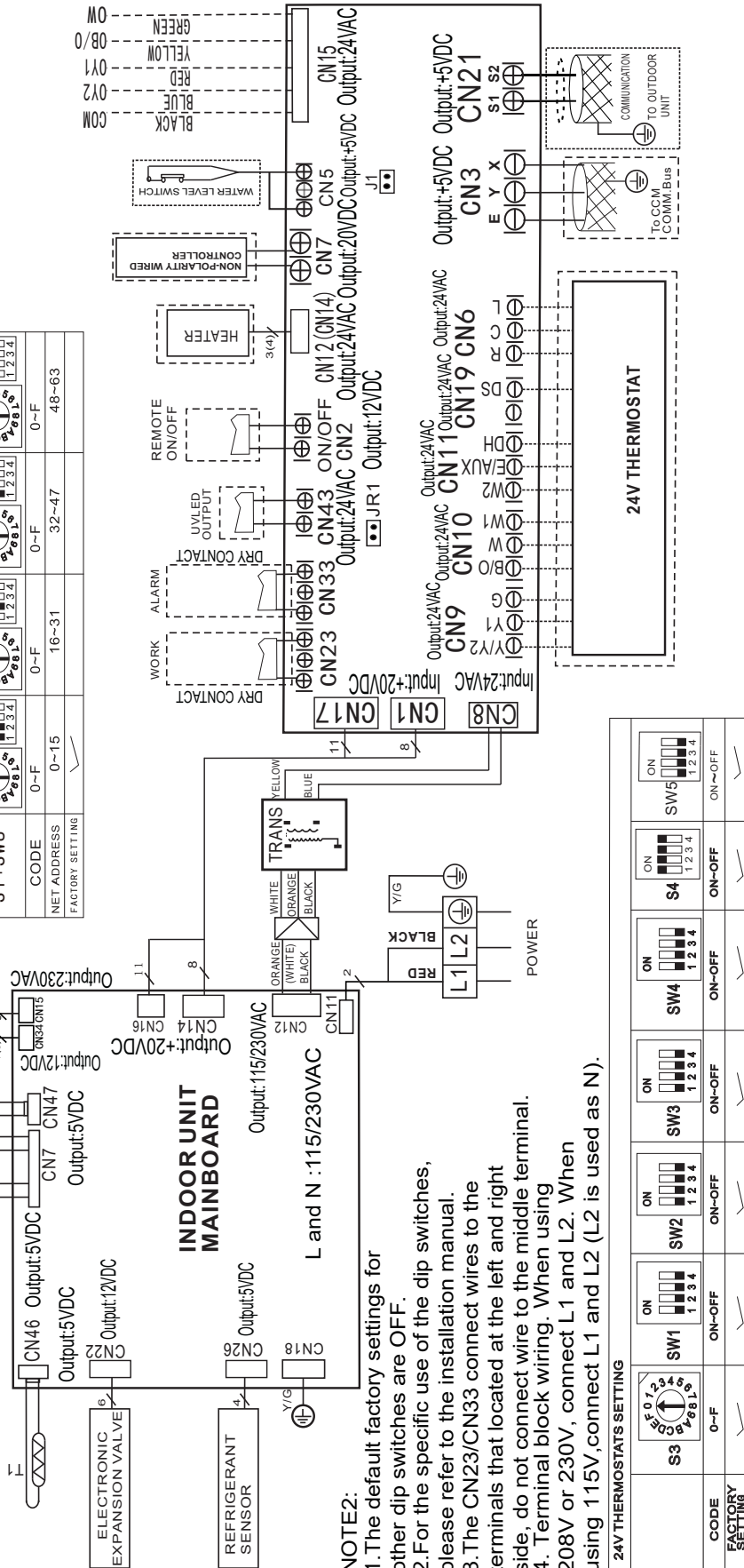

NOTE2:

1. The default factory settings for other dip switches are OFF.
2. For the specific use of the dip switches, please refer to the installation manual.
3. The CN23/CN33 connect wires to the terminals that located at the left and right side, do not connect wire to the middle terminal.
4. Terminal block wiring. When using 208V or 230V, connect L1 and L2. When using 115V, connect L1 and L2 (L2 is used as N).

DRUM3036S2A, DRUM4260S2A

WIRING DIAGRAM

CODE	PART NAME
FAN1	INDOOR ECM MOTOR
T1	ROOM TEMP. SENSOR
T2	COIL TEMP. SENSOR
T2A	INDOOR COIL INLET TEMP. SENSOR
T2B	INDOOR COIL OUTLET TEMP. SENSOR

NOTE1:

- This symbol indicates the element is optional, the actual shape shall prevail.
- Remove the short connector of JR1 when using the "ON-OFF" function.
- Remove the short connector of J1 when using the "WATER LEVEL SWITCH" function.

FOR SETTING POWER(DC MOTOR MODEL ONLY)	
ENC1	
CODE	0 3 5 8 9 A C E
CAPACITY	AUTO 12K 18K 24K 30K 36K 48K 60K
FACTORY SETTING	ACCORDING TO RELATED MODEL

FOR SETTING NET ADDRESS	
S1+SW8	
CODE	0-F 0-F 0-F 0-F 0-F 0-F
NET ADDRESS	0-15 16-31 32-47 48-63
FACTORY SETTING	

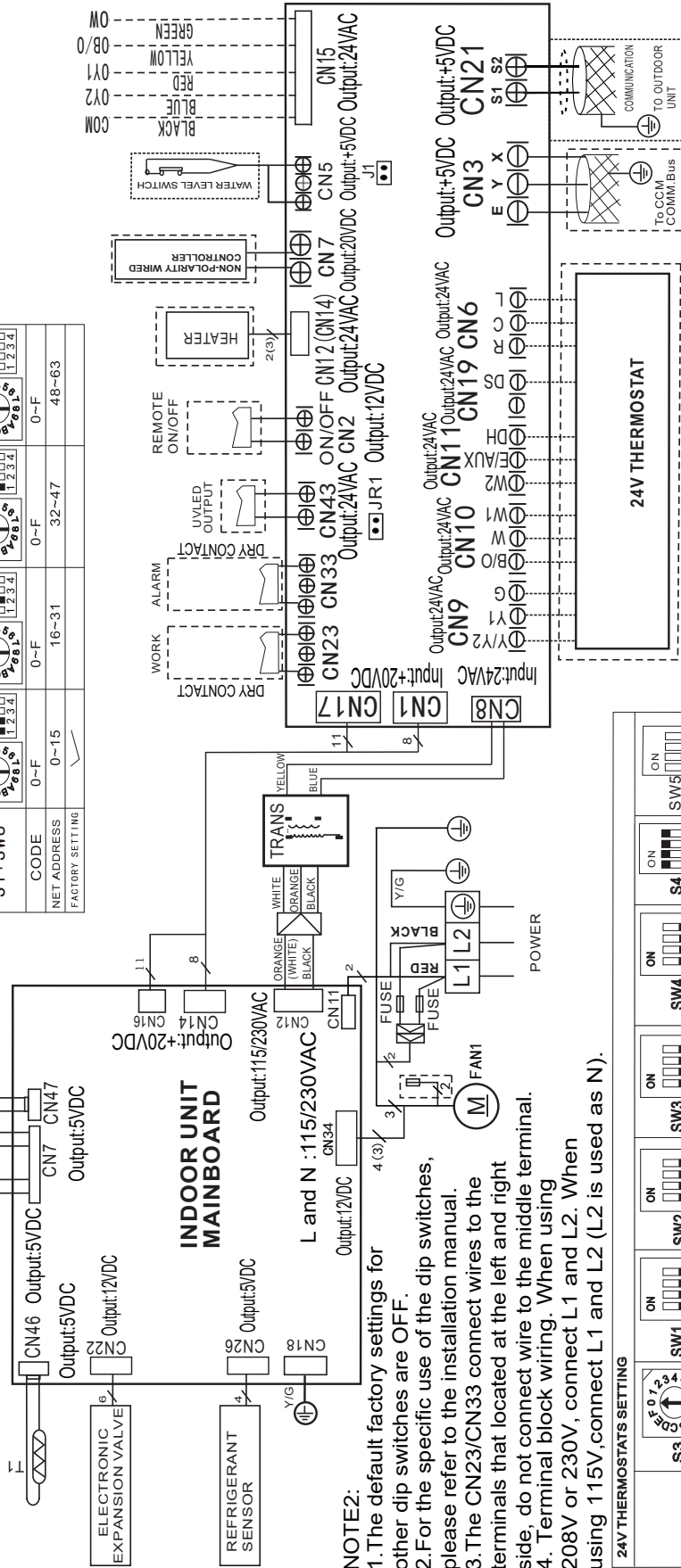

NOTE2:

- The default factory settings for other dip switches are OFF.
- For the specific use of the dip switches, please refer to the installation manual.
- The CN23/CN33 connect wires to the terminals that located at the left and right side, do not connect wire to the middle terminal.
- Terminal block wiring. When using 208V or 230V, connect L1 and L2. When using 115V, connect L1 and L2 (L2 is used as N).

24V THERMOSTATS SETTING

S3		ON-OFF	ON-OFF
SW1		ON-OFF	ON-OFF
SW2		ON-OFF	ON-OFF
SW3		ON-OFF	ON-OFF
SW4		ON-OFF	ON-OFF
SW5		ON-OFF	ON-OFF
S4		ON-OFF	ON-OFF
CODE	0-F	ON-OFF	ON-OFF
FACTORY SETTING			

ERROR AND OPERATING CODES

Error Code	Description
dF	Defrost (not an error)
FC	Forced Cooling (not an error)
EC07	ODU fan speed out of control
EC0d	ODU malfunction
EC51	ODU EEPROM parameter error
EC52	ODU coil temp. sensor (T3) error
EC53	ODU ambient temp. sensor (T4) error
EC54	COMP. discharge temp. sensor (TP) error
EC56	IDU coil outlet temp. sensor (T2B) error
ECC1	Other IDU refrigerant sensor detects leakage (Multi-zone)
EH00	IDU EEPROM malfunction
EH03	IDU fan speed out of control
EH0A	IDU EEPROM parameter error
EH0b	IDU main control board and display board communication error
EH0E	Water-level alarm malfunction
EH3A	External fan DC bus voltage is too low protection
EH3b	External fan DC bus voltage is too high fault
EH60	IDU room temp. sensor (T1) error
EH61	IDU coil temp. sensor (T2) error
EH62/EH66	Evaporator coil inlet temperature sensor T2B is in open circuit or short circuit
EH65	Evaporator coil temperature sensor T2A is in open circuit or short circuit
EHbA	Communication error between the indoor unit and the external fan module
EHb3	Communication malfunction between wire and master control
EHC1	Refrigerant sensor detects leakage
EHC2	Refrigerant sensor is out of range and leakage is detected
EHC3	Refrigerant sensor is out of range
EL01	IDU & ODU communication error
EL0C	System lacks refrigerant
EL16	Communication malfunction between adapter board and outdoor main board
FHCC	Refrigerant sensor error
FL09	Mismatch between the new and old platforms
PC00	ODU IPM module protection
PC01	ODU voltage protection
PC02	Compressor top (or IPM) temp. protection
PC03	Pressure protection (low or high pressure)
PC04	Inverter compressor drive error
PC0L	Low ambient temperature protection
----	IDUs mode conflict

THIS PAGE INTENTIONALLY LEFT BLANK.