

**UPS 32-160/2, 1 ph, 115 V, 230 V, 60 Hz**

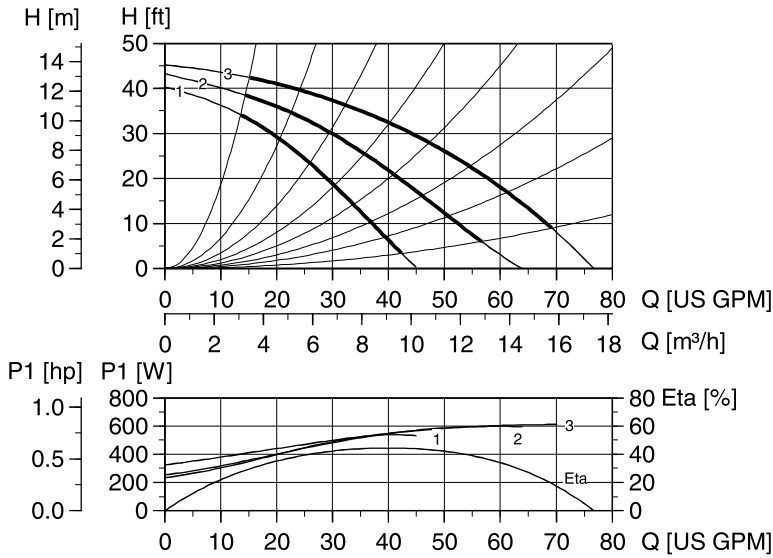

TTM00 9512 0697

- Flow range: 9 - 76 gpm
- Head range: 1 - 45 ft
- Motor: 2-pole 0.75 Hp
- Max. liquid temp (Open): +140 °F
- Max. liquid temp.: +248 °F
- Min. liquid temp.: +32 °F
- Max. system pressure: 145 psi
- Net wt: 37.0 lbs (16.8 kg)
- Gross wt.: 45.2 lbs (20.5 kg)
- Shipping volume: 1.70 ft³ (0.048 m³)
- Net wt. bronze: 37.7 lbs (17.1 kg)
- Gross wt. bronze: 45.9 lbs (20.8 kg)
- Shipping volume bronze: 1.70 ft³ (0.048 m³)

Note: ETA is calculated as wire-to-water efficiency.

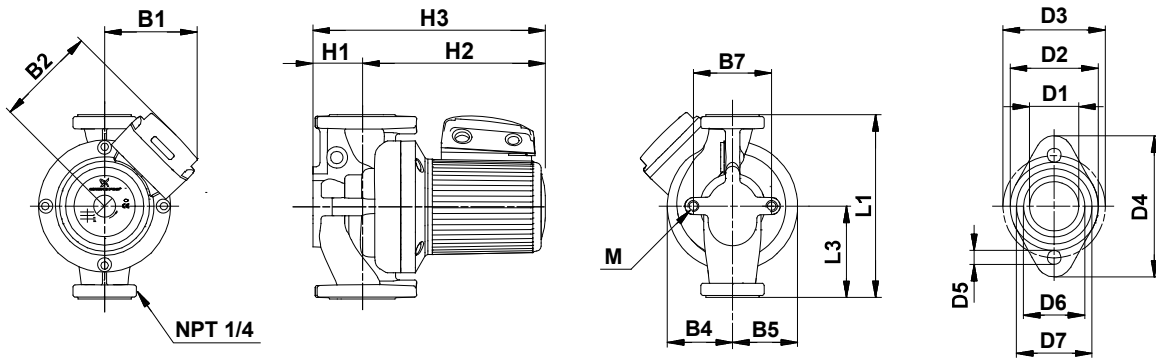

TM02 0729 5100

**Dimensions**

Model	L1	L3	B1	B2	B4	B5	B7	H1	H2	H3	D1	D2	D3	D4	D5	D6	D7	M	
UPS 32-160/2	[in]	13.50	5.50	5.31	5.56	3.00	3.00	3.19	2.69	9.50	12.16	1.44	2.50	3.42	4.63	0.50	2.06	2.56	
	[mm]	343	140	135	141	76	76	81	68	241	309	37	64	87	117	13	52	65	M12

**Product numbers**

Model type	Product number		Voltage [V]
	Cast Iron	Bronze	
UPS 32-160/2 (1 ph)	96402730	96402739	115
	96402733	96402740	230

**Connections**

Flange size	Flange type
1.5" non ANSI 2 bolt w/ (2) 0.5" dia. holes	GF 40/43

**Electrical data**

Speed	Max amps [A]		P Max [Watts]	Start amps [A]	
	115V	230V		115V	230V
3	5.80	2.90	625	14.60	6.70
2	5.80	2.90	600	14.60	6.70
1	5.50	2.75	555	13.84	6.35