

Bronze Ball Valves

Two-Piece Body • Full Port 1/4"-1" • Conventional Port 1/4"-3" •
Stainless Trim • Blowout-Proof Stem • Vented Ball

600 PSI/41.4 bar non-shock cold working pressure
150 PSI/10.3 bar saturated steam*

CONFORMS TO MSS SP-110

MATERIAL LIST

PART	SPECIFICATION
1. Handle Nut	Stainless Steel 300 Series
2. Handle	Zinc Plated Steel Clear Chromate Plastisol Coated
3. Threaded Pack Gland	Brass ASTM B 16 Alloy C36000
4. Packing	PTFE
5. Stem	Stainless Steel ASTM A 276 Type 316
6. Thrust Washer	Reinforced PTFE
7. Ball (Vented)	Stainless Steel ASTM A 276 Type 316 or ASTM A 351 Type CF8M
8. Seat Ring (2)	Reinforced PTFE
9. Body	Bronze ASTM B 584 Alloy C84400
10. Body End Piece	Bronze ASTM B 584 Alloy C84400

1/4" size only has a 304 stainless steel grounding washer.

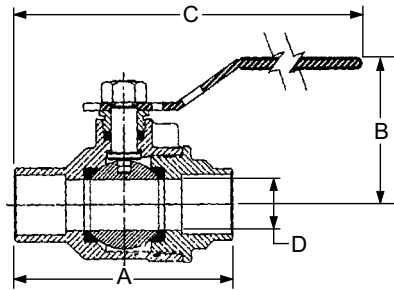

S-580-70-66
C x C

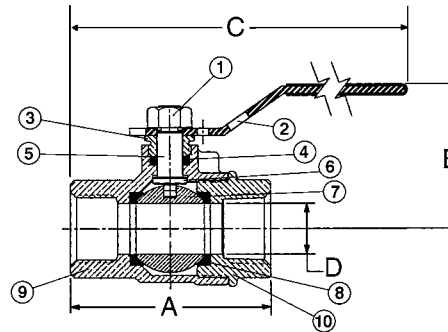

T-580-70-66
NPT x NPT



T-580-70-66
Threaded



S-580-70-66
Solder

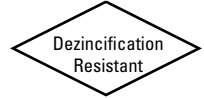

DIMENSIONS—WEIGHTS—QUANTITIES

Dimensions

Size	S-580-70-66		S-580-70-66		T-580-70-66		T-580-70-66		D	T-580-70-66		S-580-70-66		Master Ctn. Qty.				
	In.	mm.	In.	mm.	In.	mm.	In.	mm.		Lbs.	Kg.	Lbs.	Kg.					
†1/4	8	2.00	51	1.75	44	1.75	44	5.00	127	4.75	121	.38	10	.45	.21	.42	.19	100
†3/8	10	2.00	51	1.84	47	1.75	44	5.00	127	4.81	122	.38	10	.45	.21	.42	.19	100
†1/2	15	2.44	62	2.56	65	1.88	48	5.19	132	5.25	133	.50	13	.64	.29	.60	.27	100
†3/4	20	2.94	75	3.25	83	2.25	57	6.25	159	6.25	159	.75	19	1.33	.60	1.27	.58	50
†1	25	3.34	85	3.75	95	2.38	60	6.44	164	6.63	168	1.00	25	1.79	.81	1.72	.78	40
1 1/4	32	3.94	100	4.00	102	2.63	67	6.75	171	6.75	171	1.00	25	2.33	1.06	1.94	.88	20
1 1/2	40	4.31	109	4.44	113	3.00	76	8.88	226	9.00	229	1.25	32	3.49	1.58	3.10	1.40	20
2	50	4.63	118	5.50	140	3.16	80	9.06	230	9.50	241	1.50	38	5.16	2.34	4.67	2.12	10
2 1/2	65	5.84	148	7.28	185	3.50	89	9.66	245	10.38	264	2.00	51	8.98	4.07	8.92	4.04	6
3	80	7.09	180	8.78	223	4.41	112	11.53	293	12.38	314	2.50	64	17.38	7.88	16.59	7.52	4

† NIBCO supplies full port T or S-585-70-66 on this size.

Note: solder end is designed to be soft-soldered into lines using solders with the melting point not exceeding 500°F. Higher temperature solders will damage the seat material. See installation sheet packaged with valves.

♦ For detailed operating pressure, refer to pressure temperature chart on page 42.

**LEAD FREE*
OPTION
AVAILABLE**

**OXYGEN
SERVICE
OPTION
AVAILABLE**

Visit our website for the most current information.

*Weighted average lead content ≤ 0.25%