

## OPERATING INSTRUCTIONS

**THE PUMP:** This pump is a totally enclosed, submersible dewatering unit. It is powered by a 1/3 HP, 12 volt DC 30 AMP motor. Battery clips on the power cord allow easy connection to any 12 volt vehicle battery.

**SWITCHING:** The on-off switch is located on the power cord.

**CONNECTING TO BATTERY:** When connecting the clips to a battery, arcing is eliminated by keeping the on-off switch in the "off" position. Connect the red battery clamp to the positive (+) battery terminal. Connect the black battery clamp to ground: preferably on the vehicle's engine to a solid, metallic, stationary point. The connection should be at least 18 inches (480mm) from the battery.

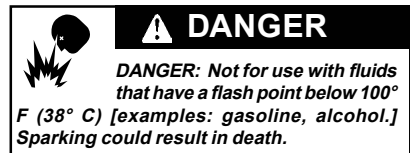
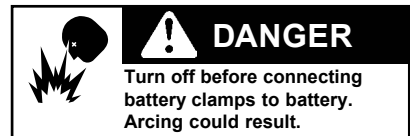
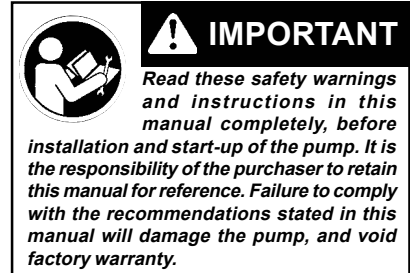
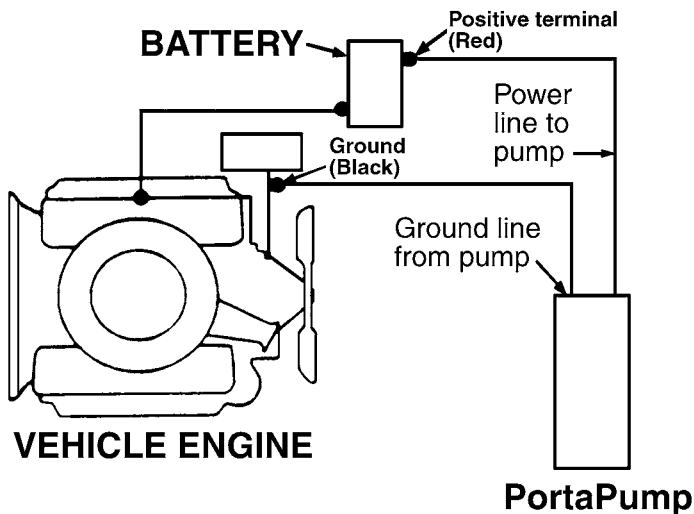

**HOSE:** Since the pump develops relatively low pressure, it is recommended that non-collapsible hose be used for maximum pumping rates.

**HOISTING & LOWERING:** Attach a line to the metal handle on the top of the pump for hoisting or lowering the unit. **Do not use power cable for handling unit.**

**TO OPERATE:** Lower unit into liquid to be pumped and activate switch. Pump can be run for a few minutes without liquid, however, **do not run completely dry for extended periods.** Damage to shaft seal may result.

**RUNNING TIME:** This unit draws about 30 amperes and can be operated about 1 hour on a fully charged 55 AMP-hour battery and still permit starting of vehicle under normal conditions. Caution should be used when running time exceeds 30 or 40 minutes without engine running to recharge battery, particularly in cold weather when battery efficiency is lowered. Battery size (AMP-hour rating) and the use of other accessories such as lights and radios, etc., must be taken into consideration for practical running periods without engine running.

**OVERLOAD PROTECTION** is provided by means of a 40 amp automatic reset circuit breaker, located under top cover.

## TROUBLE SHOOTING

**NOTE:** Most common cause of failure to run is due to hardened mud and sand at impeller. Remove strainer to check.

### MOTOR WILL NOT RUN:

1. Poor connection at battery.
2. Impeller locked with foreign material.
3. Insufficient impeller clearance.
4. Damaged power cable or loose connection internally in motor assembly.
5. Bad switch or circuit breaker. Connect power leads direct to motor leads to check.
6. Worn motor brushes or out of position to make contact with armature.

### PERFORMANCE LOW:

1. Strainer screen partially plugged.
2. Impeller rubbing. Check freeness of rotation with screwdriver inserted through hole in base plated into slotted end of shaft.
3. Battery not fully charged.
4. Discharge restriction such as kinked hose or excessive discharge head.

### Motor runs backwards:

1. Check wiring for correct polarity.

## SERVICE AND REPAIR INSTRUCTION

**DISASSEMBLY:** Impeller and shaft seal can be inspected and serviced from lower end of pump by removal of 4 capscrews securing base plate, strainer screen, and suction cover. Screwdriver slot is provided in end of motor shaft to turn shaft while holding impeller for removal. This permits removal of impeller without disassembly of upper motor housing to hold motor shaft. Alternately, there is a shaft extension with two flats on the rear of the motor for use when the impeller is difficult to remove. The upper motor cover must be removed to expose this shaft extension.

To service motor remove 4 hex nuts and bump top cover free from housing tube. Raise sufficiently to disconnect power cable connections. Slide housing tube up from pump casing and motor will be exposed for service or removal.

When servicing the PortaPump and replacing the impeller (part number 444.001.010.) or suction cover (part number 258.001.157.) follow these instructions: The impeller has been revised to typically require 1 shim (previously 7). The suction cover has been revised to require 1 gasket (previously 5).

**IMPORTANT:** Make certain that wire leads are installed per diagram below. Install top cover as indicated by arrow and instruction on top of cover. Make sure wires do not contact motor shaft when installing motor cover.

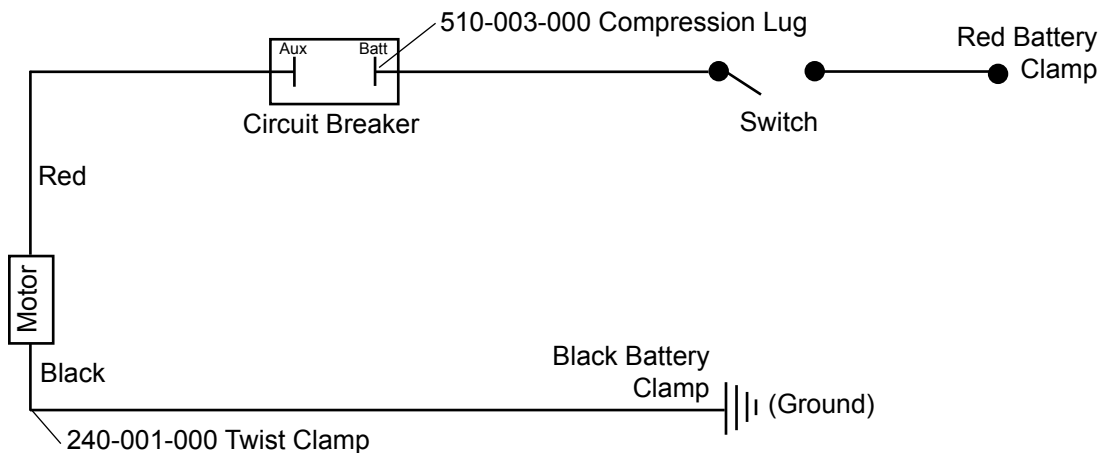

## WARRANTY

This unit is guaranteed for a period of 5 years against defective material and workmanship.



# SERVICE AND OPERATING MANUAL

## PortaPump® Model SPA 1½-E Model SPA40-E Design Level 3

ITEM NO.	PART NUMBER	DESCRIPTION	TOTAL RQD.	
1	710-004-330	Screw, Self-Tapping	2	<p>Repair Parts shown in <b>bold face (darker)</b> type are more likely to need replacement after extended periods of normal use. They are readily available from most Warren Rupp distributors. The pump owner may prefer to maintain a limited inventory of these parts in his own stock to reduce repair downtime to a minimum.</p> <p><b>IMPORTANT:</b> When ordering repair parts always furnish pump model number, serial number and type number.</p> <p style="text-align: center;"><b>MATERIAL CODES</b></p> <p style="text-align: center;"><u>The Last 3 Digits of Part Number</u></p> <p>000...Assembly, sub-assembly; and some purchased Items</p> <p>010...Cast Iron</p> <p>012...Powered Metal</p> <p>015...Ductile Iron</p> <p>020...Ferritic Malleable Iron</p> <p>025...Music Wire</p> <p>080...CarbonSteel AISI B-1112</p> <p>100...Alloy 20</p> <p>110...Alloy Type 316 Stainless Steel</p> <p>111...Alloy Type 316 Stainless Steel (Electro Polished)</p> <p>112...Alloy "C"</p> <p>113...Alloy Type 316 Stainless Steel (Hand Polished)</p> <p>114...303 Stainless Steel</p> <p>115...302/304 Stainless Steel</p> <p>117...440-C Stainless Steel (Martensitic)</p> <p>120...416 Stainless Steel (Wrought Martensitic)</p> <p>123...410 Stainless Steel (Wrought Martensitic)</p> <p>148...Hardcoat Anodized Aluminum</p> <p>149...2024-T4 Aluminum</p> <p>150...6061-T6 Aluminum</p> <p>151...6063-T6 Aluminum</p> <p>152...2024-T4 Aluminum (2023-T351)</p> <p>154...Almag 35 Aluminum</p> <p>155 or 156...356-T6 Aluminum</p> <p>157...Die Cast Aluminum Alloy #380</p> <p>158...Aluminum Alloy SR-319</p> <p>159...Anodized Aluminum</p> <p>162...Brass, Yellow, Screw Machine Stock</p> <p>165...Cast Bronze, 85-5-5-5</p> <p>166...Bronze SAE 660</p> <p>170...Bronze, Bearing Type, Oil Impregnated</p> <p>180...Copper Alloy</p> <p>310...Kynar Coated</p> <p>330...Zinc Plated Steel</p> <p>331...Chrome Plated Steel</p> <p>332...Electroless Nickel Plated</p> <p>335...Galvanized Steel</p> <p>336...Zinc Plated Yellow Brass</p> <p>337...Silver Plated Steel</p> <p>340...Nickel Plated</p> <p>342...Filled Nylon</p> <p>354...Injection Molded #203-40 Santoprene - Duro 40D ± 5; Color: RED</p> <p>355...Thermoplastic Elastomer</p> <p>356...Hytrel</p> <p>357...Rupplon (Urethane Rubber) Color coded: PURPLE</p> <p>358...Rupplon (Urethane Rubber) Color coded: PURPLE (Some Applications, Compression Mold)</p> <p>359...Urethane Rubber</p> <p>360...Buna-N Rubber Color coded: RED</p> <p>361...Buna-N</p> <p>363...Viton (Fluorel) Color coded: YELLOW</p> <p>364...E.P.D.M. Rubber Color coded: BLUE</p> <p>365...Neoprene Rubber Color coded: GREEN</p> <p>366...Nitrile, USDA Approved</p> <p>368...EPDM, USDA Approved</p> <p><i>List continued next page</i></p>
2	258-017-157	Cover, Motor	1	
3	545-005-330	Hex Nut	1	
<b>4</b>	<b>405-009-000</b>	<b>Handle</b>	1	
5	543-001-162	Nut, Gland	2	
6	770-007-162	Spacer, Gland	2	
<b>7</b>	<b>675-016-360</b>	<b>Ring, Sealing</b>	<b>2</b>	
8	545-004-330	Hex Nut	4	
9	900-004-330	Lock Washer	4	
10	807-011-330**	Stud	4	
<b>11</b>	<b>270-001-000</b>	<b>Circuit Breaker</b>	<b>1</b>	
12	170-028-330	Capscrew, Hex Head	4	
13	900-001-330	Lock Washer	8	
<b>14</b>	<b>360-001-440</b>	<b>Gasket, Casing</b>	<b>1</b>	
15	170-003-115	Capscrew, Hex Head	4	
<b>16</b>	<b>444-001-010</b>	<b>Impeller</b>	<b>1</b>	
<b>17</b>	<b>740-001-115</b>	<b>Shim</b>	<b>As. Req.*</b>	
18	258-001-157	Cover, Suction	1	
19	612-001-156	Plate, Strainer	1	
20	700-001-330	Screen, Strainer	1	
21	181-001-155	Casing, Volute, 1½ NPT	1	
	181-001-155E	Casing, Volute, 1½ BSPT (tapered)	1	
<b>22</b>	<b>560-022-360</b>	<b>O-Ring</b>	<b>2</b>	
<b>23</b>	<b>720-005-000</b>	<b>Seal</b>	<b>1</b>	
24	860-011-150**	Tube, Casing	1	
25	525-005-000	Motor	1	
26	200-003-000	Clamp, Cable	1	
27	706-007-330	Screw, Machine	1	
28	150-036-000	Power Cable Assembly Complete	1	
29	900-002-330	Washer, Lock	1	
30	510-003-000	Lug, Compression	1	
31	240-001-000	Nut, Insulated Wire	1	
<b>For Models SPA153F, 12DC3 and SPA15BSP3F, 12DC3: (Not Shown)</b>				
10	807-011-330	Stud	2	
	807-012-330	Stud (replaces 2 807-011-330)	2	
	325-001-330	Foot, Mounting	2	
	547-001-330	Stop Nut 5/16-18Vac	2	
	904-001-330	Washer	2	
<b>Service Items: (Not Shown)</b>				
	475-220-000	Design Level 2 to Design Level 3 Conversion Kit		

\* Typically 1

\*\* Items 10 & 24 available as a kit #475-132-000

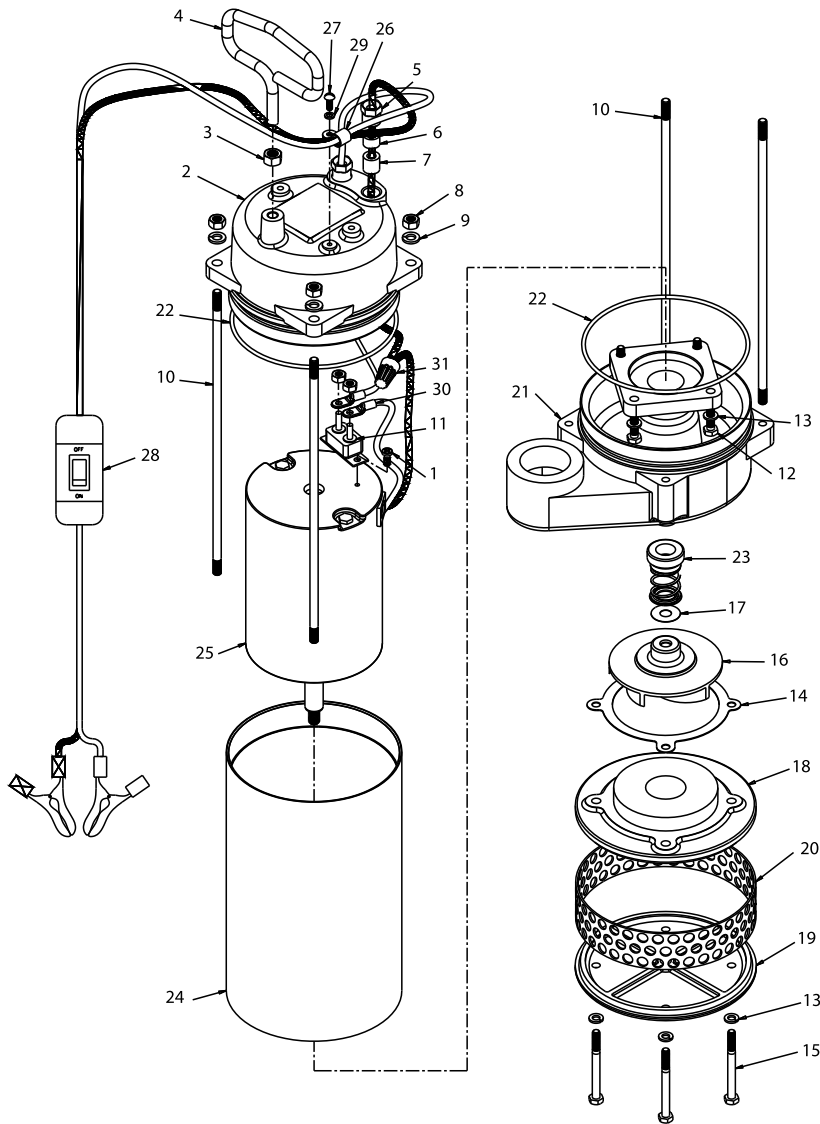

Repair Parts shown in **bold face (darker)** type are more likely to need replacement after extended periods of normal use. They are readily available from most Warren Rupp distributors. The pump owner may prefer to maintain a limited inventory of these parts in his own stock to reduce repair downtime to a minimum.

**IMPORTANT:** When ordering repair parts always furnish pump model number, serial number and type number.

**MATERIAL CODES**  
**The Last 3 Digits of Part Number**

*Continued from previous page*

- 370...Butyl Rubber Color coded: BROWN
- 371...Phlithane (Tuftane)
- 375...Fluorinated Nitrile
- 378...High density Polypropylene
- 405...Cellulose Fibre
- 408...Cork and Neoprene
- 425...Compressed Fibre
- 426...Blue Gard
- 440...Vegetable Fibre
- 465...Fibre
- 500...Delrin 500
- 501...Delrin 570
- 505...Acrylic Resin Plastic
- 520...Injection Molded PVDF Natural Color
- 540...Nylon
- 541...Nylon
- 542...Nylon
- 544...Nylon Injection Molded
- 550...Polyethylene
- 551...Polypropylene
- 552...Unfilled Polypropylene
- 553...Unfilled Polypropylene
- 555...Polyvinyl Chloride
- 570...Rulon II
- 580...Ryton
- 590...Valox
- 591...Nylatron G-S
- 592...Nylatron NSB
- 600...Virgin PTFE Tetrafluoroethylene (TFE)
- 601...Virgin PTFE (Bronze and moly filled)
- 602...Filled Virgin PTFE
- 603...Blue Gylon
- 604...Virgin PTFE
- 606...Virgin PTFE
- 610...Virgin PTFE Encapsulated Viton
- 611...Virgin PTFE Encapsulated Viton

Delrin, Viton and Hytrel are registered trademarks of E.I. DuPont.

Gylon is a registered trademark of Garlock, Inc.

Nylatron is a registered trademark of Polymer Corp.

Rulon II is a registered trademark of Dixon Industries Corporation.

Hastelloy-C is a registered trademark of Cabot Corp.

Ryton is a registered trademark of Phillips Chemical Company.

Valox is a registered trademark of General Electric Company.

Rupplon, SandPIPER, PortaPump, Tranquilizer, SludgeMaster and Warren Rupp are trademarks of Warren Rupp, Inc.

# INSTRUCTIONS FOR HANDLE CONVERSION

405-009-000 Handle (1)

545-005-330 Hex Nut (1)

Remove Eye Bolt And Nut And Install 405-009-000 Metal Handle. Lock In Place With 545-005-330 Hex Nut (Included In Kit).

170-032-330 Capscrews (2)

900-001-300 Lock Washers (2)

Remove Plastic Handle And Install New Hardware Directly To Bracket Assembly.

