



The Gruvlok® Figure 7000 Lightweight Coupling is designed for applications where system flexibility is desired.

The Figure 7000 Lightweight Coupling is approximately 30% lighter in weight than the Figure 7001 Coupling. Working pressure ratings shown are for reference only and are based on Schedule 40 pipe. For the latest UL/ULC listed, LPCB, VdS and FM Approved pressure ratings versus pipe schedule, see [www.anvilintl.com](http://www.anvilintl.com) or contact your local Anvil Representative.

The Figure 7000 Lightweight Coupling with a Pre-Lubricated Grade "E" EPDM, Type "A" gasket (coupling is easily identified by purple nuts) is intended for use in fire protection systems installed in accordance with NFPA Standard 13 "Sprinkler Systems".



For Listings/Approval Details and Limitations, visit our website at [www.anvilintl.com](http://www.anvilintl.com) or contact an Anvil® Sales Representative.

- Available galvanized.

\* When ordering, refer to product as FP7000.

## MATERIAL SPECIFICATIONS

**HOUSING:**

Ductile Iron conforming to ASTM A-536, Grade 65-45-12

**ANSI BOLTS & HEAVY HEX NUTS:**

Heat treated, oval-neck track head bolts conforming to ASTM A-183 Grade 2 with a minimum tensile strength of 110,000 psi and heavy hex nuts of carbon steel conforming to ASTM A-563 Grade A or Grade B, or J995 Grade 2. Bolts and nuts are provided zinc electroplated as standard.

**METRIC BOLTS & HEAVY HEX NUTS:**

Heat treated, zinc electroplated oval-neck track head bolts made of carbon steel with mechanical properties per ISO 898-1 Class 8.8. Hex nuts and bolts are zinc electroplated followed by a yellow chromate dip.

**COATINGS:**

- Rust inhibiting paint Color: ORANGE (standard)
  - Hot Dipped Zinc Galvanized (optional)
  - Other available options: Example: RAL3000 or RAL9000 Series
- For other coating requirements contact an Anvil Representative.

**LUBRICATION:**

- Standard Gruvlok
- Gruvlok Xtreme™ required for dry pipe systems and freezer applications.

**GASKETS: Materials**

Properties as designated in accordance with ASTM D-2000.

- Pre-Lubricated Grade "E" EPDM, Type A Gasket** (Violet color code)  
-40°F to 150°F (Service Temperature Range)(-40°C to 66°C)  
Recommended for wet and dry (oil free air) pipe fire protection sprinkler systems. For dry pipe systems and freezer applications, Gruvlok Xtreme™ Lubricant is required.
- Grade "EP" EPDM** (Green and Red color code)  
-40°F to 250°F (Service Temperature Range)(-40°C to 121°C)  
Recommended for water service, diluted acids, alkalies solutions, oil-free air and many other chemical services.  
**NOT FOR USE IN PETROLEUM APPLICATIONS.**

**GASKET TYPE:**

- Standard C Style
- Flush Gap

PROJECT INFORMATION		APPROVAL STAMP	
Project:		<input type="checkbox"/> Approved	
Address:		<input type="checkbox"/> Approved as noted	
Contractor:		<input type="checkbox"/> Not approved	
Engineer:		Remarks:	
Submittal Date:			
Notes 1:			
Notes 2:			

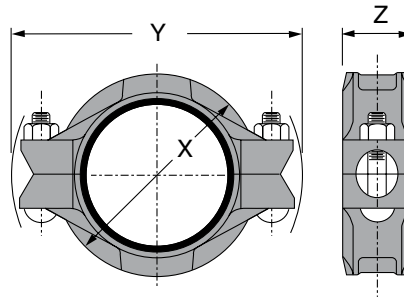

### FIGURE 7000 LIGHTWEIGHT COUPLING

Nominal Size	Pipe O.D.	Max. Working Pressure ▲	Max. End Load	Range of Pipe End Separation	Deflection From $\mathcal{C}$		Coupling Dimensions			Coupling Bolts		Specified Torque §		Approx. Wt. Ea.
					Per Coupling	Pipe	X	Y	Z	Qty.	Size	Min.	Max.	
In./DN(mm)	In./mm	PSI/bar	Lbs./kN	In./mm	Degrees	In./Ft.	In./mm	In./mm	In./mm		In./mm	Ft.-Lbs./N-m	Lbs./Kg	
1¼ 32	1.660 42.2	600 41.4	1,299 5.78	0-½ 0-0.79	1° 5'	0.23 18.8	2¾ 70	4¾ 111	1¾ 44	2	¾ x 2¼ M10 x 57	30 40	45 60	1.4 0.6
1½ 40	1.900 48.3	600 41.4	1,701 7.57	0-½ 0-0.79	0° 57'	0.20 16.5	3 76	4¾ 117	1¾ 44	2	¾ x 2¼ M10 x 57	30 40	45 60	1.5 0.7
2 50	2.375 60.3	600 41.4	2,658 11.82	0-½ 0-0.79	0° 45'	0.16 13.1	3½ 89	5½ 140	1¾ 44	2	¾ x 2¼ M10 x 57	30 40	45 60	1.7 0.8
2½ 65	2.875 73.0	600 41.4	3,895 17.33	0-½ 0-0.79	0° 37'	0.13 10.9	4 102	5¾ 146	1¾ 44	2	¾ x 2¼ M10 x 57	30 40	45 60	1.9 0.9
3 O.D. 76.1	2.996 76.1	600 41.4	4,230 18.82	0-½ 0-0.79	0° 36'	0.13 10.4	4 102	6½ 156	1¾ 44	2	— M10 x 57	30 40	45 60	2.3 1.0
3 80	3.500 88.9	600 41.4	5,773 25.68	0-½ 0-0.79	0° 31'	0.11 8.9	4¾ 117	6¾ 171	1¾ 44	2	½ x 2¾ M12 x 70	80 110	100 150	2.9 1.3
4¼ O.D. 108.0	4.250 108.0	600 41.4	8,512 37.86	0-¾ 0-2.38	1° 16'	0.26 22.0	5½ 140	7¼ 197	2 51	2	½ x 3 M12 x 76	80 110	100 150	4.0 1.8
4 100	4.500 114.3	600 41.4	9,543 42.45	0-¾ 0-2.38	1° 12'	0.25 20.8	5½ 149	8½ 206	2 51	2	½ x 3 M12 x 76	80 110	100 150	4.6 2.1
5¼ O.D. 133.0	5.236 133.0	500 34.5	10,766 47.89	0-¾ 0-2.38	1° 2'	0.21 17.9	6½ 165	9½ 232	2 51	2	⅝ x 3½ M16 x 85	100 135	130 175	5.7 2.6
5½ O.D. 139.7	5.500 139.7	500 34.5	11,879 52.84	0-¾ 0-2.38	0° 59'	0.20 17.0	6¾ 171	9½ 238	2 51	2	— M16 x 85	100 135	130 175	6 2.7
5 125	5.563 141.3	500 34.5	12,153 54.06	0-¾ 0-2.38	0° 58'	0.20 16.8	7 178	9½ 244	2 51	2	⅝ x 3½ M16 x 85	100 135	130 175	6.1 2.8
6¼ O.D. 159.0	6.259 159.0	500 34.5	15,384 68.43	0-¾ 0-2.38	0° 51'	0.18 14.9	7½ 191	10½ 264	2 51	2	⅝ x 3½ M16 x 85	100 135	130 175	6.7 3.0
6½ O.D. 165.1	6.500 165.1	500 34.5	16,592 73.80	0-¾ 0-2.38	0° 50'	0.17 14.5	7¾ 197	10¾ 273	2 51	2	— M16 x 85	100 135	130 175	7.0 3.2
6 150	6.625 168.3	500 34.5	17,236 76.67	0-¾ 0-2.38	0° 49'	0.17 14.1	8 203	11 279	2 51	2	⅝ x 3½ M16 x 85	100 135	130 175	8.1 3.7
8 200	8.625 219.1	500 34.5	29,213 129.95	0-¾ 0-2.38	0° 37'	0.13 10.9	10 264	13¼ 337	2¾ 60	2	¾ x 4½ M20 x 110	130 175	180 245	14.2 6.4

Not for use in copper system.

Range of Pipe End Separation and Angular Deflection values are for roll grooved pipe and may be doubled for cut groove pipe.

§ – For additional Bolt Torque information see Technical Data Section.

▲ – Working Pressure Ratings are for reference only and based on Sch. 40 pipe. For the latest UL/ULC, FM, VdS and LPCB pressure ratings versus pipe schedule, please visit [anvilintl.com](http://anvilintl.com) or contact your local Anvil Representative.

Other sizes available, see Gruvlok Catalog or contact an Anvil Representative.

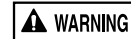

**For dry pipe systems and freezer applications lubrication of the gasket is required, Gruvlok® Xtreme™ Lubricant is required.**