

True Union Ball Check Valve (Regular Style)



Sample Engineering Specification

All thermoplastic check valves shall be True Union Ball type constructed from PVC Type I, ASTM D 1784 Cell Classification 12454 or CPVC Type IV, ASTM D 1784 Cell Classification 23447. All O-rings shall be EPDM or FKM. All valve union nuts shall have Buttress threads. All valve components shall be replaceable. All EPDM valves shall be certified by NSF International for use in potable water service. All 1/2" - 2" valves shall be pressure rated at 235 psi and all 2-1/2" - 6" and all flanged valves shall be pressure rated at 150 psi for water at 73° F, as manufactured by Spears® Manufacturing Company.

Quick-View Valve Selection Chart

Valve Size	O-ring Material	PVC Part Number ¹			Pressure Rating
		Threaded	Socket	Flanged	
1/2	EPDM	2229-005	included	2223-005	235 psi Non-Shock Water @ 73°F (Flanged 150 psi Non-Shock) Water @ 73°F
	FKM	2239-005	included	2233-005	
3/4	EPDM	2229-007	included	2223-007	
	FKM	2239-007	included	2233-007	
1	EPDM	2229-010	included	2223-010	
	FKM	2239-010	included	2233-010	
1-1/4	EPDM	2229-012	included	2223-012	
	FKM	2239-012	included	2233-012	
1-1/2	EPDM	2229-015	included	2223-015	
	FKM	2239-015	included	2233-015	
2	EPDM	2229-020	included	2223-020	
	FKM	2239-020	included	2233-020	
2-1/2	EPDM	2221-025	2222-025	2223-025	150 psi Non-Shock Water @ 73°F
	FKM	2231-025	2232-025	2233-025	
3	EPDM	2221-030	2222-030	2223-030	
	FKM	2231-030	2232-030	2233-030	
4	EPDM	2221-040	2222-040	2223-040	
	FKM	2231-040	2232-040	2233-040	
6 ² venturied	EPDM	---	2222-060	2223-060	
	FKM	---	2232-060	2233-060	

1: For CPVC valves, add the letter "C" to part numbers listed (e.g., 2339-005C).
2: Consists of 4" True Union Ball Valve with two 4" x 6" Adapters.

Features — PVC, CPVC

Flow tested design provides quick response with positive seal for prevention of system back flow in industrial and chemical processing applications. Available in IPS Sizes 1/2"- 4" with socket, threaded or flanged end connectors. 6" Venturied valve (4" valve with 4 x 6 adapters) available with either socket or flanged end connection. Also available with metric 20mm - 110mm or 1/2" - 4" BSP thread end connectors. **Note:** Seal carrier is **NOT** blocked (for Safe-T- Blocked® seal carrier design, see True Union 2000 Industrial Ball Check Valve).

- Chemical & Corrosion Resistant PVC or CPVC Construction
- Strong, Buttress Thread Union Nuts
- Fully Serviceable, Replaceable Components
- Schedule 80 Full-Port Design
- Uses Standard O-ring Seat
- EPDM or FKM O-rings
- Sizes 1/2" - 2" Pressure Rated to 235 psi @ 73°F, Sizes 2-1/2" - 6" and all Flanged Pressure Rated to 150 psi @ 73°F
- Suitable for Either Horizontal or Vertical Installations
- EPDM valves NSF® Certified for Potable Water use
- Suitable for Vacuum Service
- Assembled with Silicone-Free, Water Soluble Lubricants
- Manufactured to ASTM F 1970

Ball Check Foot Valves

Spears® Ball Check Valves easily convert to foot valves utilizing optional Foot Valve Screen adapters found in Ball Valve Accessories section.





True Union Ball Check Valve (Regular Style)

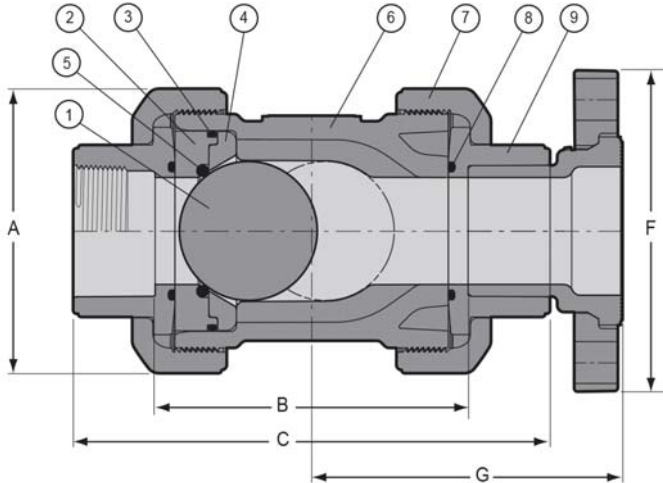

Replacement Parts

No.	Component	Qty.	Material
1	Ball	1	PVC/CPVC
2	Seal Carrier	1	PVC/CPVC
3	Carrier O-ring	1	EPDM/FKM
4	Seat Plate	1	PVC/CPVC
5	Seat O-ring	1	EPDM/FKM
6	Body	1	PVC/CPVC
7	Union Nut	2	PVC/CPVC
8	End Connector O-ring	2	EPDM/FKM
9	End Connector	2	PVC/CPVC

Dimensions, Weights, C_v Values & Horizontal Closing Requirements

Nominal Size	Dimension Reference (inches, ± 1/16)					Approx. Wt. (Lbs.)		C _v ³ Values		Horizontal Closing	
	A	B ¹	C	F	G	PVC	CPVC	Threaded/Socket	Flanged	Feet of Head (water)	GPM (minimum)
1/2	2-9/16	3-5/16	5-1/8	3-1/2	3-7/16	.56	.61	11	10	1.6	.10
3/4	3	4	6-1/8	3-7/8	3-15/16	.91	.99	18	17	1.6	.10
1	3-7/16	4-1/4	6-1/2	4-1/4	4-3/8	1.20	1.30	32	30	1.6	.25
1-1/4	3-11/16	4-1/2	7	4-5/8	4-9/16	1.50	1.60	58	55	1.6	.40
1-1/2	4-3/8	5-5/16	8-1/16	5	5-1/4	2.50	2.70	94	89	1.6	.75
2	5-1/8	5-3/4	8-3/4	6	5-5/8	3.70	4.00	153	146	1.6	.75
2-1/2	7-3/8	8-5/16	11-7/8	7	7-1/4	11.10	12.21	159	155	1.0	1.50
3	7-3/8	8-1/8	11-7/8	7-1/2	7-1/2	10.84	11.91	378	361	1.0	4.00
4	8-15/16	8-1/4	12-15/16	9-1/16	8-1/8	17.60	19.36	551	537	1.0	5.50
6 Socket ²	8-15/16	19-5/8	26-1/16	N/A	N/A	22.45	27.61	N/A	N/A	N/A	N/A
6 Flanged ²	11-3/16	29-3/8	N/A	11-1/4	14-3/4	31.21	37.07	N/A	N/A	N/A	N/A

1: Valve Lay Length
 2: Consists of 4" True Union Ball Check Valve with two 4" x 6" Adapters.
 3: Gallons per minute at 1 psi pressure drop.
 C_v Values for 6" venturied flange and socket valves are not available.

Temperature Pressure Rating

System Operating Temperature °F (°C)		100 (38)	110 (43)	120 (49)	130 (54)	140 (60)	150 (66)	160 (71)	170 (77)	180 (82)	190 (88)	200 (93)	210 (99)	
Valve Pressure Rating psi (MPa)	1/2" - 2"	PVC	235 (1.62)	211 (1.45)	150 (1.03)	75 (.52)	50 (.34)	-0- (-0-)	-0- (-0-)	-0- (-0-)	-0- (-0-)	-0- (-0-)	-0- (-0-)	
		CPVC	235 (1.62)	219 (1.51)	170 (1.17)	145 (1.00)	130 (.90)	110 (.76)	90 (.62)	80 (.55)	70 (.48)	60 (.41)	50 (.34)	-0- (-0-)
	2-1/2" - 6"	PVC	150 (1.03)	135 (.93)	110 (.76)	75 (.52)	50 (.34)	-0- (-0-)	-0- (-0-)	-0- (-0-)	-0- (-0-)	-0- (-0-)	-0- (-0-)	-0- (-0-)
		CPVC	150 (1.03)	140 (.97)	130 (.90)	120 (.83)	110 (.76)	100 (.70)	90 (.62)	80 (.55)	70 (.48)	60 (.41)	50 (.34)	-0- (-0-)

NOTE: Flanged Valves have a base pressure rating of 150 psi.

General Installation Information: Ball check valves may be installed in either horizontal or vertical position. A minimum of ten (10) pipe diameters distance maintained from any pump or other source of turbulence. Ball Check valves **MUST** be installed with the valves **FLOW** arrow pointing in the direction of flow.