

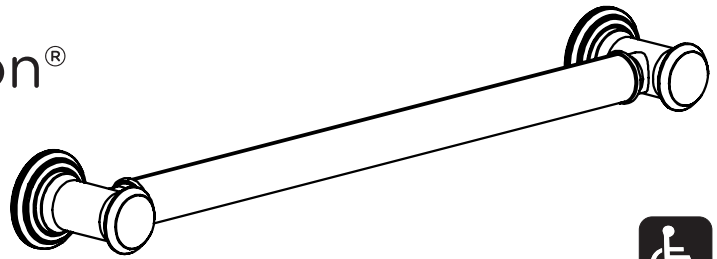

Location:



**583GB-24 (36)
ADA Grab Bar Series
Specification Submittal**

Model Numbers	Specification
<input type="checkbox"/> 583GB-24 24" Grab Bar for ADA Applications <input type="checkbox"/> 583GB-36 36" Grab Bar for ADA Applications	<ul style="list-style-type: none"> • Supports up to 250 lbs. • 1-1/2" bar diameter • 3" flange diameter • Bar extends 1-1/2" from wall • Concealed mounting for a clean look • Meets WW-P-541/8B Federal Specification for Manufacturing • Meets ADA load requirements when properly installed • Stainless steel construction • Grab bar compatible with Winglts stainless steel grab bar fasteners (p/n GBW40) for drywall applications
Finish Options	Warranty
<input type="checkbox"/> STN Satin Nickel finish <input type="checkbox"/> MB Matte Black Finish <input type="checkbox"/> BBZ Brushed Bronze Finish Note: Append appropriate suffix to model number.	<p>Limited Lifetime - to the original end purchaser in consumer/residential installations. 10 Years - for commercial/industrial installations. Refer to www.symmons.com/warranty for complete warranty information.</p> 

Dimensions

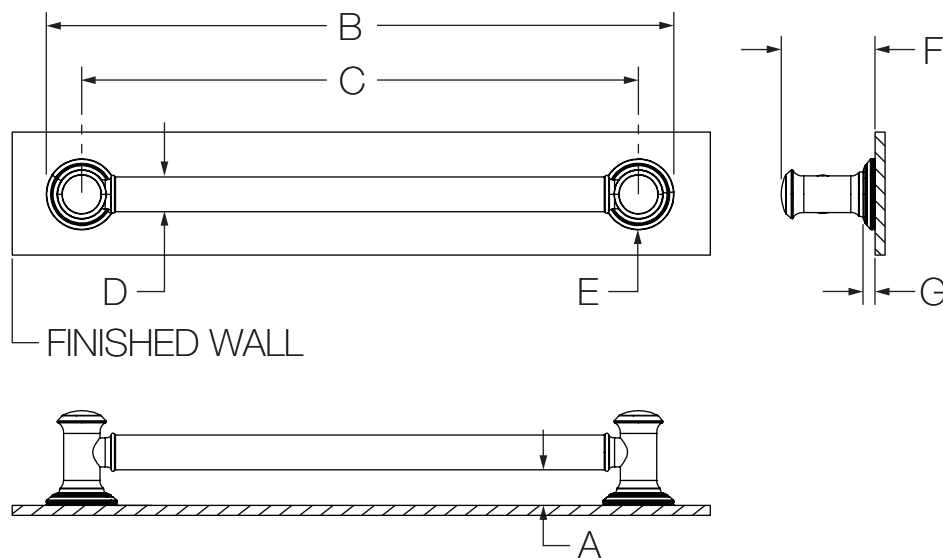

Measurements	
A	1-1/2", 38 mm
B	25-1/4", 641 mm (583GB-24) 37-1/4", 946 mm (583GB-36)
C	24", 610 mm (583GB-24) 36", 914 mm (583GB-36)
D	Ø 1-1/2", 38 mm
E	(2x) Ø 3-1/16", 103 mm
F	4-1/16", 78 mm
G	1/2", 13 mm

Note: Dimensions subject to change without notice.