



5893TRM
Tub/Shower Trim
Specification Submittal

Location:

Model Numbers

- 5893TRM**
Hand Shower Trim
- Valve Options:**
- 261 Series Temptrol Shower Valve with TRM modifier
- 161 Series Temptrol Shower requires TC modifiers

Compliance

- ASME A112.18.1 / CSA B125.1.
 - WaterSense 1.5 gpm (5.7 L/min) / 2.0 gpm (7.6 L/min).
 - Lever handle and hand shower meet ADA requirements for operation.
- 
- 
- 

Warranty

Limited Lifetime - for residential installations.
10 Years - for commercial/industrial installations.
Refer to www.symmons.com/warranty for complete warranty information.



Feature Highlights

- Braston® Hand Shower Trim.
- Requires Temptrol® Pressure Balancing Shower Valve.
- Metal lever handle.
- 30” slide bar for hand shower wand.
- Dual checks for backflow protection.
- 60” flexible metal hose.
- 7-mode HydroMersion™ hand shower with NPSO.
- 2.0 gpm (7.6 L/min) flow restrictor.
- Tub spout and showerhead not included.
- Components made from metal and nonmetal materials, plated in standard Polished Chrome finish.
- For optional in-line vacuum breaker order p/n EF-109.

Modifications

- 15**  1.5 gpm (5.7 L/min) flow restrictor
- L2** Less handshower
- L7** Less handle
- BBZ** Brushed Bronze finish
- MB** Matte Black finish
- STN** Satin Nickel finish
- TC** Test Cap Trim (includes TA-10 & T-12A) *used with 161 Series Temptrol Valve*

Note: Append appropriate suffix to model number.

SKU Builder

Series	Finish	Modifier	Flow Rate	Trim (required)	Test Cap	Final SKU
5893	MB	L2		TRM	TC	5893MBL2TRMTC
5893	MB			TRM		5893MBTRM

Note: No more than two modifiers (L1-L7) permitted when ordering. Modifiers will list in numerical order.

Architectural/Engineering Specification

Symmons Braston® Hand Shower Trim _____ Includes Braston® Hand Shower Trim powered by Temptrol® Pressure Balancing Shower Valve. Features include metal lever handle, 30” slide bar for hand shower wand, dual checks for backflow protection, 60” flexible metal hose, 7-mode HydroMersion™ hand shower with NPSO, 2.0 gpm (7.6 L/min) flow restrictor. Components made from metal and nonmetal materials, plated in standard Polished Chrome finish. For optional in-line vacuum breaker order p/n EF-109. 10 Year Commercial Warranty. ASME A112.18.1/CSA B125.1, WaterSense 1.5/2.0 complaint. Lever handle and hand shower meet ADA requirements for operation. Available options: 15 = 1.5 gpm (5.7 L/min) flow restrictor, L2 = Less handshower, L7 = Less handle, BBZ = Brushed Bronze finish, MB = Matte Black finish, STN = Satin Nickel finish, and TC = Test Cap Trim.

Dimensions

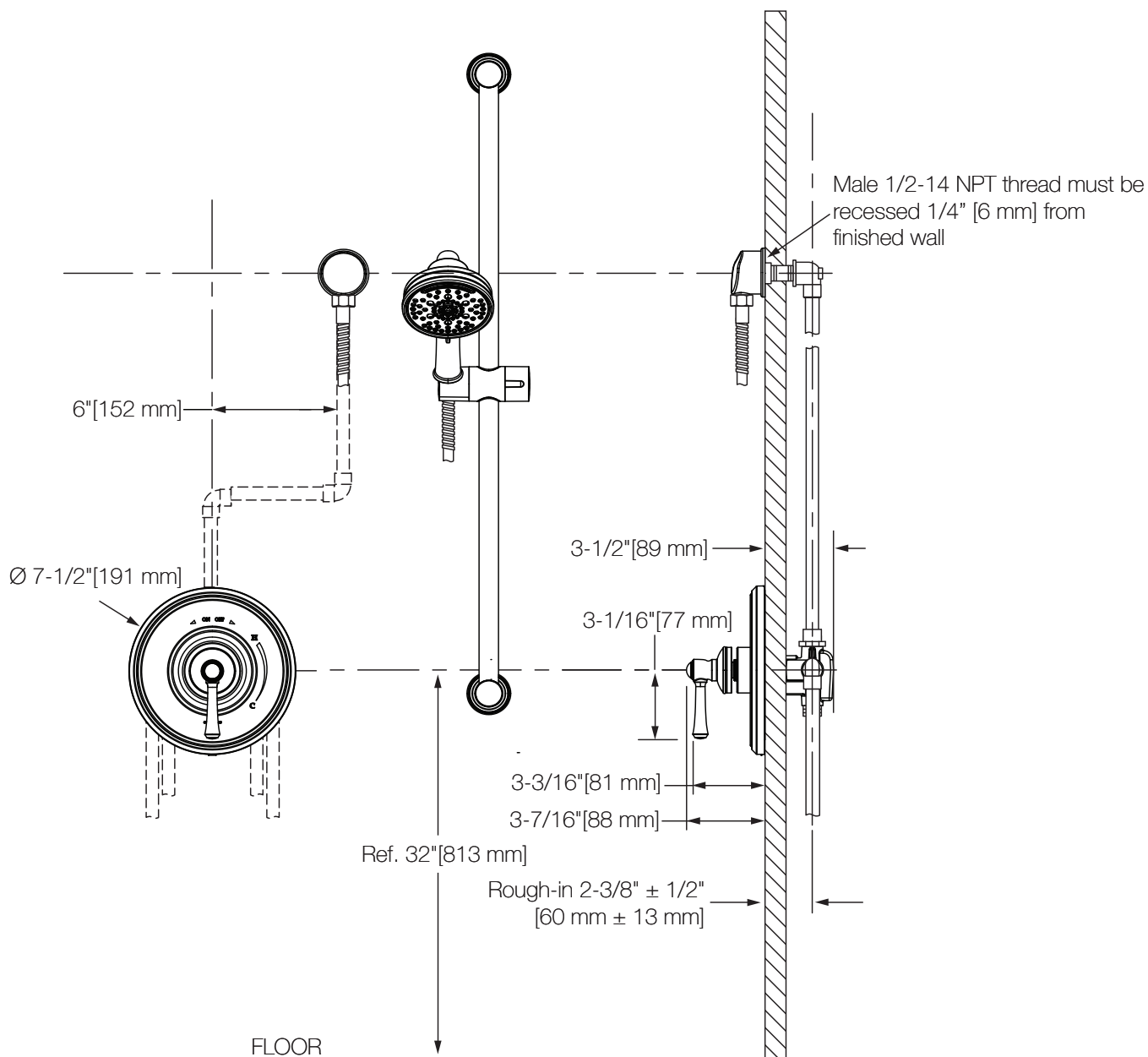

Notes:

- 1) Valve body and piping not included and shown as reference only.
- 2) Plaster shield (p/n T-176) for dry wall, plaster or other type walls 1/2" or greater.
- 3) All dimensions measured from nominal rough-in (see 2-3/8" ± 1/2" [60 mm ± 13 mm] as reference).
- 4) Dimensions subject to change without notice.