

MSZ-HX09NL & MUZ-HX09NL  
9,000 BTU/H WALL-MOUNTED INDOOR UNIT  
9,000 BTU/H INVERTER HEAT PUMP OUTDOOR UNIT



Job Name:

System Reference:

Date:

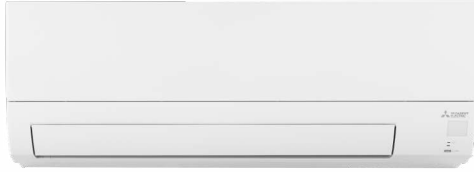

Indoor Unit.....MSZ-HX09NL

Outdoor Unit.....MUZ-HX09NL



#### INDOOR UNIT FEATURES

- 12-hour timer
- Auto restart
- Dual Barrier Coating: The patented Dual Barrier Coating reduces the collection of contaminants like dust, fibers, smoke, and oil on the inner surface of the heat pump, resulting in optimal airflow and easier maintenance. (HX Fan Only)
- Econo Cool: Econo Cool temporarily and automatically adjusts the airflow based on heat exchanger temperature. The set temperature is increased slightly, which saves energy, while maintaining comfort.
- Electrostatic Enzyme Filter: Charged with static electricity, the Electrostatic filter is designed to attract and filter charged particles which can include airborne non-living particulates.
- Four fan speed options: Low, Medium, high, Super-high
- Multiple control options including: Hand-held Remote Controller (provided with unit), comfort app, third-party interfaces and both wired and wireless controllers
- Smart Dry Mode: Improves humidity control with minimal over-cooling of the space

#### OUTDOOR UNIT FEATURES

- Blue Fin Coating: An anti-corrosion treatment applied to the aluminum fins of the heat exchanger of the outdoor unit to protect against corrosion caused by salt, sulfur, and other airborne contaminants, especially in coastal and industrial areas.
- INVERTER-driven compressor: An inverter-driven compressor generates the precise capacity needed to maintain a temperature set point.
- Powered by Outdoor Unit: The outdoor unit powers the indoor unit, and should a power outage occur, the system is automatically restarted when power returns

## SPECIFICATIONS: MSZ-HX09NL & MUZ-HX09NL

Cooling at 95F <sup>1</sup>	Maximum Capacity	Btu/h	11,000
	Rated Capacity	Btu/h	9,000
	Minimum Capacity	Btu/h	3,600
	Maximum Power Input	W	1,100
	Rated Power Input	W	720
	Moisture Removal	Pints/h	1.6
	Sensible Heat Factor	-	0.8
Heating at 47F <sup>2</sup>	Power Factor [208V / 230V]	%	89 / 89
	Maximum Capacity	Btu/h	13,000
	Rated Capacity	Btu/h	10,900
	Minimum Capacity	Btu/h	4,000
	Maximum Power Input	W	1,400
	Rated Power Input	W	900
Heating at 17F <sup>3</sup>	Power Factor [208V / 230V]	%	91 / 91
	Maximum Capacity	Btu/h	7,200
	Rated Capacity	Btu/h	6,800
	Maximum Power Input	W	1,230
Heating at 5F <sup>4</sup>	Rated Power Input	W	820
	Maximum Capacity	Btu/h	7,700
Heating at -5F <sup>5</sup>	Maximum Power Input	W	1,250
	Maximum Capacity	Btu/h	6,420
Efficiency	SEER2		20
	EER2 <sup>1</sup>		12.5
	HSPF2 [IV]		10
	COP at 47°F <sup>2</sup>		3.55
	COP at 17°F at Maximum Capacity <sup>3</sup>		1.7
	COP at 5°F at Maximum Capacity <sup>4</sup>		1.8
	COP at -5°F at Maximum Capacity <sup>5</sup>		1.48
Electrical	ENERGY STAR <sup>®</sup> Certified		Yes
	Voltage, Phase, Frequency	V AC / V AC, $\phi$ , Hz	208 / 230, 1, 60
	Guaranteed Voltage Range	V AC	187 - 253
	Voltage: Indoor - Outdoor, S1-S2	V AC	230
	Voltage: Indoor - Outdoor, S2-S3	V DC	24
	Short-circuit Current Rating [SCCR]	kA	5
	Recommended Fuse/Breaker Size (Outdoor)	A	15
Indoor Unit	Recommended Wire Size [Indoor - Outdoor]	AWG	14
	MCA	A	1
	Fan Motor Output	W	30
	Airflow Rate at Cooling, Dry	CFM	144, 211, 296, 379
	Airflow Rate at Cooling, Wet	CFM	129, 190, 267, 342
	Airflow Rate at Heating, Dry	CFM	144, 221, 317, 390
	Sound Pressure Level [Cooling]	dB (A)	22, 30, 37, 43
	Sound Pressure Level [Heating]	dB (A)	22, 30, 37, 43
	Drain Pipe Size O.D.	inch [mm]	5/8 [15.88]
	Dual Barrier Coating on Heat Exchanger		No
	External Finish Color		Munsell 0.7PB 9.2/0.4
	Unit Dimensions (W x D x H)	inch x inch x inch [mm x mm x mm]	33 x 9-1/4 x 11-1/32 [838 x 235 x 280]
	Package Dimensions (W x D x H)	inch x inch x inch [mm x mm x mm]	36 x 13-1/4 x 11-1/2 [920 x 340 x 300]
	Unit Weight	lbs [kg]	20 [9]
	Package Weight	lbs [kg]	24 [10.50]
Fan Motor Type		DC Motor	
IDU Operating Temp. Range	Cooling Intake Air Temp [Maximum / Minimum]	°FDB, °FWB / °FDB, °FWB	90, 73 / 67, 57
	Heating Intake Air Temp [Maximum / Minimum]	°FDB	80 / 70

### NOTES

<sup>1</sup>Cooling at 95°F (Indoor: 80°F DB, 67°F WB // Outdoor: 95°F DB, 75°F WB)

<sup>2</sup>Heating at 47°F (Indoor: 70°F DB, 60°F WB // Outdoor: 47°F DB, 43°F WB)

<sup>3</sup>Heating at 17°F (Indoor: 70°F DB, 60°F WB // Outdoor: 17°F DB, 15°F WB)

<sup>4</sup>Heating at 5°F (Indoor: 70°F DB, 60°F WB // Outdoor: 5°F DB, 4°F WB)

<sup>5</sup>Heating at -5°F (Indoor: 70°F DB, 60°F WB // Outdoor: -5°F DB, -6°F WB)

<sup>\*</sup> Indoor/Outdoor Unit Operating Temperature Range (Cooling Air Temp [Maximum / Minimum]):

• Applications should be restricted to comfort cooling only; equipment cooling applications are not recommended for low ambient temperature conditions.

<sup>\*\*</sup> Outdoor Unit Operating Temperature Range (Cooling Thermal Lock-out / Re-start Temperatures; Heating Thermal Lock-out / Re-start Temperatures):

• System cuts out in heating mode and automatically restarts at these temperatures.

## SPECIFICATIONS: MSZ-HX09NL & MUZ-HX09NL

Outdoor Unit	MCA	A	10
	MOCP	A	17
	Fan Motor Full Load Amperage	A	0.71
	Fan Motor Output	W	55
	Airflow Rate Cooling	CFM	1,141
	Airflow Rate Heating	CFM	1,196
	Defrost Method		Reverse Cycle
	Coating on Heat Exchanger (Bluefin, Sea Coast)		Yes, Yes
	Sound Pressure Level, Cooling <sup>1</sup>	dB (A)	46
	Sound Pressure Level, Heating <sup>2</sup>	dB (A)	50
	Compressor Type		Single Rotary
	Compressor Model		KRB073FATMC
	Compressor Oil [Type // Charge]	Type // oz	RM68EH // 9.13
	External Finish Color		Munsell 3Y 7.8/1.1
	Base Pan Heater		Optional
	Unit Dimensions (W x D x H)	inch x inch x inch [mm x mm x mm]	31-1/2 x 11-1/4 x 21-5/8 [800 x 285 x 550]
	Package Dimensions (W x D x H)	inch x inch x inch [mm x mm x mm]	37-1/16 x 14-31/32 x 24-13/16 [940 x 380 x 630]
Unit Weight	lbs [kg]	65 [29.5]	
Package Weight	lbs [kg]	77 [32.4]	
ODU Operating Temp. Range	Cooling Intake Air Temp [Maximum / Minimum*]	°FDB	115 / 14
	Cooling Thermal Lock-out / Re-start Temperatures**	°FDB	-1 / 3
	Heating Intake Air Temp [Maximum / Minimum]	°FDB, °FWB / °FDB, °FWB	75, 65 / -5, -6
	Heating Thermal Lock-out / Re-start Temperatures**	°FDB	-14 / -4
Refrigerant	Type		R454B
	Pre-Charged Refrigerant Amount	lbs, oz	1, 6
	Maximum Pre-Charged Piping Length	ft [m]	25 [7.50]
	Additional Refrigerant Charge Per Additional Piping Length	oz/ft mm	0.22 [9.52]
Piping	Liquid Pipe Size O.D. [Flared]	inch [mm]	1/4 [6.35]
	Maximum Piping Length	ft [m]	65 [20]
	Maximum Height Difference	ft [m]	40 [12]
	Maximum Number of Bends		10

### NOTES

<sup>1</sup>Cooling at 95°F (Indoor: 80°F DB, 67°F WB // Outdoor: 95°F DB, 75°F WB)

<sup>2</sup>Heating at 47°F (Indoor: 70°F DB, 60°F WB // Outdoor: 47°F DB, 43°F WB)

<sup>3</sup>Heating at 17°F (Indoor: 70°F DB, 60°F WB // Outdoor: 17°F DB, 15°F WB)

<sup>4</sup>Heating at 5°F (Indoor: 70°F DB, 60°F WB // Outdoor: 5°F DB, 4°F WB)

<sup>5</sup>Heating at -5°F (Indoor: 70°F DB, 60°F WB // Outdoor: -5°F DB, -6°F WB)

\* Indoor/Outdoor Unit Operating Temperature Range (Cooling Air Temp [Maximum / Minimum]):

• Applications should be restricted to comfort cooling only; equipment cooling applications are not recommended for low ambient temperature conditions.

\*\* Outdoor Unit Operating Temperature Range (Cooling Thermal Lock-out / Re-start Temperatures; Heating Thermal Lock-out / Re-start Temperatures):

• System cuts out in heating mode and automatically restarts at these temperatures.

## INDOOR UNIT ACCESSORIES: MSZ-HX09NL

Wired Remote Controller	Deluxe Wired MA Remote Controller <sup>1</sup>	PAR-42MAAUB
	Simple Direct Wired Remote Controller	PAC-SDW01RC-1
	Simple MA Remote Controller <sup>1</sup>	PAC-YT53CRAU-J
	Touch MA Wired Remote Controller <sup>1</sup>	PAR-CT01MAU-SB
Condensate	Blue Diamond Advanced Mini Condensate Pump w Reservoir Sensor 208230V recommended	X87-721
	Blue Diamond Alarm Extension Cable 65 Ft	C13-192
	Blue Diamond MaxiBlue Advanced Mini Condensate Pump w Reservoir Sensor 110V up to 48000 BTUH recommended	X87-711
	Blue Diamond MegaBlue Advanced Condensate Pump w Reservoir Sensor	X87-835
	Blue Diamond MicroBlue Mini Condensate Pump 110208230V up to 18000 BTUH	X86-003
	Blue Diamond MultiTank collection tank for use with multiple pumps	C21-014
	Blue Diamond Sensor Extension Cable 15 Ft	C13-103
	Drain Pan Level SensorControl	SS610E
	Fascia Kit for MicroBlue Pump mounts the MicroBlue and sensor directly beneath indoor unit	T18-016
	Refco Condensate Pump 100-240 VAC up to 120000 BTUH	COMBI
	Refco Condensate Pump 100-240 VAC	GOBI-II
	REFCO PUMP 100-240 VAC 5060 HZ	X86-011
	Sauermann Condensate Pump	SI30-230
Lineset	15 x 1/4 x 15 3/8 Lineset Twin-Tube Insulation	MLS143812T-15
	30 x 1/4 x 30 3/8 Lineset Twin-Tube Insulation	MLS143812T-30
	50 x 1/4 x 50 3/8 Lineset Twin-Tube Insulation	MLS143812T-50
	65 x 1/4 x 65 3/8 Lineset Twin-Tube Insulation	MLS143812T-65
Filter	Electro Static Anti-allergy Enzyme Filter	MAC-2320FT-E
	Microparticle Filter	MAC-EMF515FT-E
Power Supplies and Auxiliary Components	Backup Heat Relay Kit Adapter for CN24 or CN152 Connector	CN24RELAY-KIT-CM3
Control Interface	Airzone Wired Blueface Controller Black	AZZBSBLUEZEROCN
	Airzone Wired Blueface Controller White	AZZBSBLUEZEROCB
	Airzone Wireless Lite Controller Black	AZZBSLITERN
	Airzone Wireless Lite Controller White	AZZBSLITERB
	Airzone Wireless Think Controller Black	AZZBSTHINKRN
	Airzone Wireless Think Controller White	AZZBSTHINKRB
	IT Extender for kumo station	PAC-WHS01IE-E
	kumo station for the Comfort app	PAC-WHS01HC-E
	M-Net I/O Control Interface for M-Series <sup>2</sup>	MAC-334IF-E
	Procon BACnet and Modbus Interface	PAC-UKPRC001-CN-1
	Thermostat Interface for 3rd Party Thermostats	PAC-US445CN-1
	Wireless Interface Adapter for the Comfort app	PAC-USWHS002-WF-2
Wireless Remote Controller	Lockdown Bracket for Wireless Handheld Remote Controllers	RCMKP1CB
	RedLINK Wireless Remote Controller	MHK2
Drain Hose	Flexible Mini-Split Drain Hose	DRX-16
Disconnect Switch	30A600VUL fits 2 X 4 utility box - Black	TAZ-MS303
	30A600VUL fits 2 X 4 utility box - White	TAZ-MS303W
Remote Sensor	Remote Temperature Sensor for MFZ MLZ and MSZ models	M21EAA307
	Wireless temperature and humidity sensor for the Comfort app	PAC-USWHS003-TH-1
<p><b>NOTES</b></p> <p><sup>2</sup>Allows IDU Connection to MA Controller:  Deluxe MA Remote Controller  Simple MA Controller  Touch MA Controller</p> <p><sup>1</sup>Requires MAC-334IF-E Interface to connect MA controller  <sup>1</sup>Requires MAC-334IF-E Interface to connect MA controller  <sup>1</sup>Requires MAC-334IF-E Interface to connect MA controller</p>		

## OUTDOOR UNIT ACCESSORIES: MUZ-HX09NL

Mini-Split Wire	14 Gauge 4 wire Armored MiniSplit Cable250 ft roll	SW144-250
	14 Gauge 4 wire Armored MiniSplit Cable50 ft roll	SW144-50
	14 Gauge 4 wire MiniSplit Cable250 ft roll	S144-250
	14 Gauge 4 wire MiniSplit Cable50 ft roll	S144-50
Snow/Rain Diverter	SnowRain Diverter	SRD-1
Air Outlet Guide	Air Outlet Guide	MAC-881SG-E
Drain Socket	Drain Socket	MAC-871DS
Control/Service Tool	M- & P-Series Maintenance Tool Cable Set	M21EC0397
	Maintenance Tool Interface	PAC-USCMS-MN-1
Stand	18 Single Fan Stand	QSMS1801M
	24 Single Fan Stand	QSMS2401M
	Condenser Wall Bracket - Stainless Steel Finish	QSWBSS
	Condenser Wall Bracket	QSWB2000M-1
	Outdoor Unit 3-14 inch Mounting Base Pair - Plastic	DSD-400P
	Outdoor Unit Stand 12 High	QSMS1201M
Mounting Pad	Condensing Unit Mounting Pad 16 x 36 x 3	ULTRILITE1
Optional Defrost Heater	Base Heater	MAC-650BH-U
	Base Heater	MAC-640BH-U
Hail Guards	Hail Guard	HG-B4
NOTES		

# INDOOR UNIT DIMENSIONS: MSZ-HX09NL

**MSZ-HX09NL- U1**  
**MSZ-HX12NL- U1**

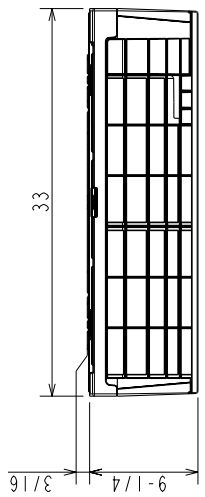
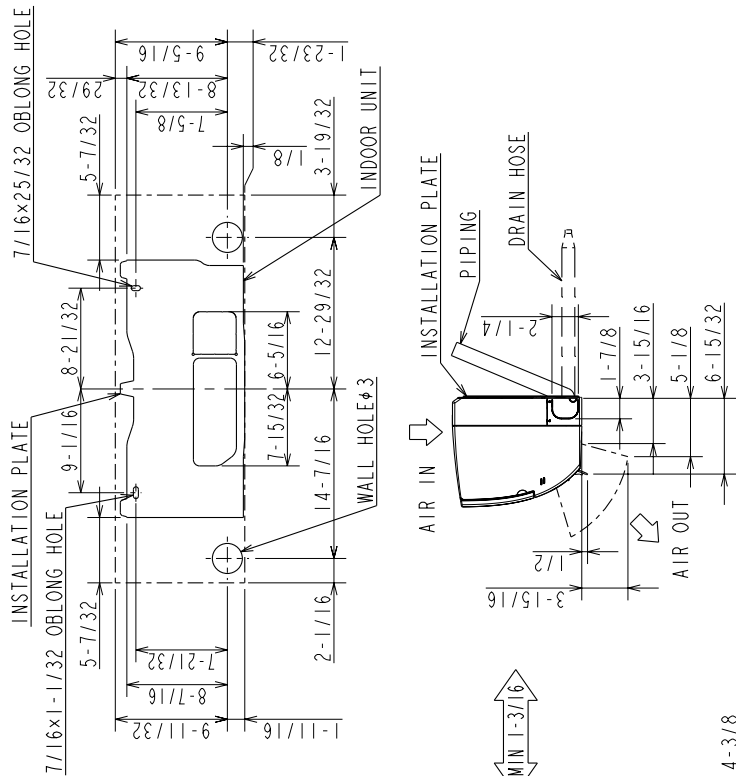

IN CASE OF LEFT,  
 LEFT REAR, OR  
 LEFT UNDER PIPING  
 (USING SPACER),  
 MIN 4-29/32

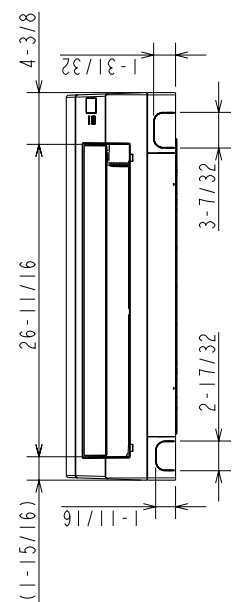
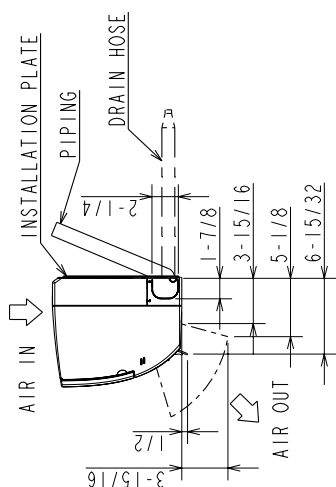
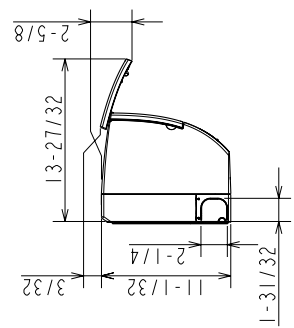
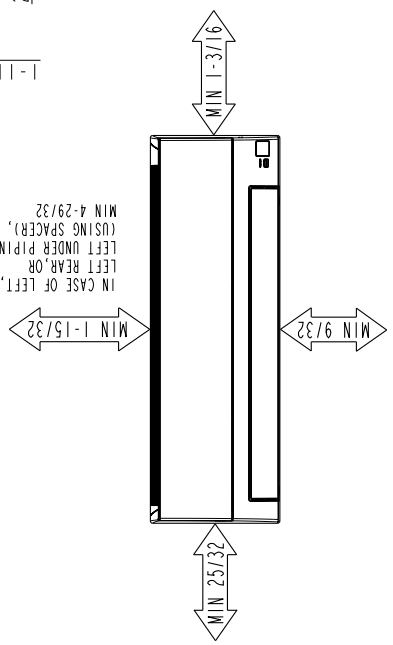

INSULATION	φ1-15/32 O.D
LIQUID LINE (FLARED CONNECTION φ1/4)	φ1/4 - 19-11/16
GAS LINE (FLARED CONNECTION φ3/8)	φ3/8 - 17-23/32
DRAIN HOSE CONNECTED PART φ5/8 O.D	INSULATION φ1-5/32

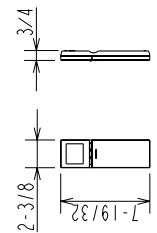

# OUTDOOR UNIT DIMENSIONS: MUZ-HX09NL

## MUZ-HX09NL-U1 MUZ-HX12NL-U1

### REQUIRED SPACE

\*1 4 in. (100 mm) or more when front and sides of the unit are clear

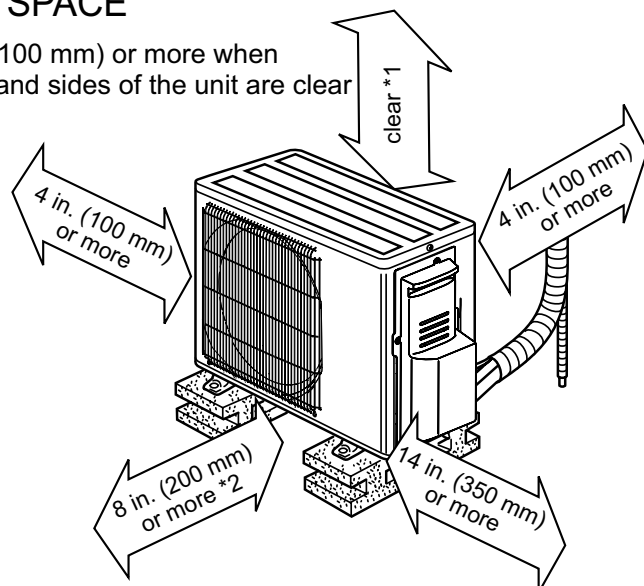

\*2 When any 2 sides of left, right and rear of the unit are clear

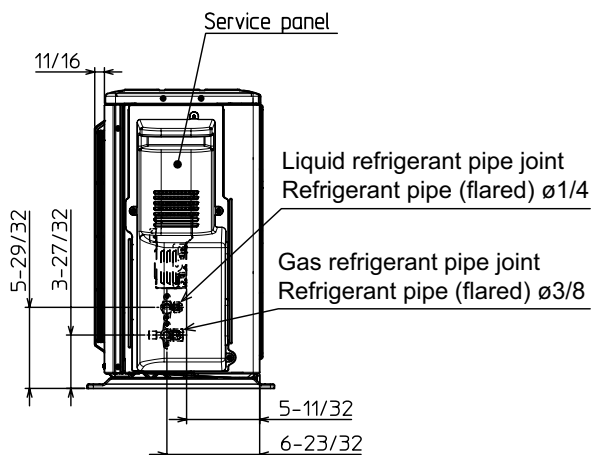
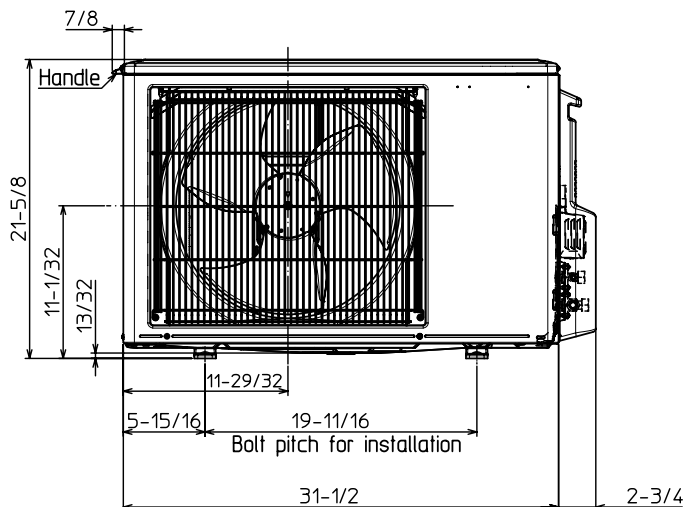
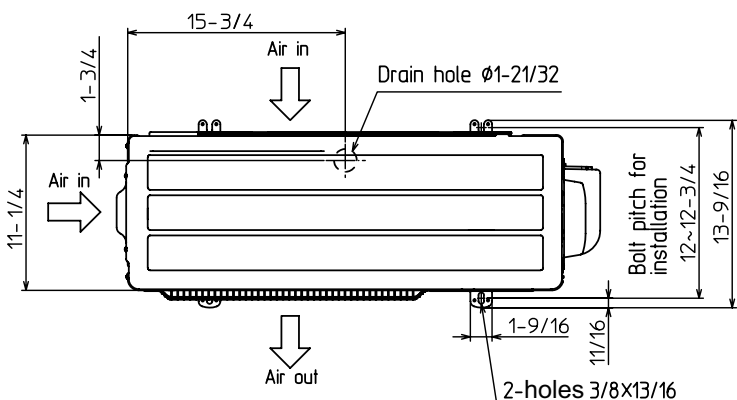

REFRIGERANT PIPE JOINT	LIQUID REFRIGERANT PIPE	FLARED 1/4"
	GAS REFRIGERANT PIPE	FLARED 3/8"

1340 Satellite Boulevard Suwanee, GA 30024  
Toll Free: 800-433-4822 <https://mitsubishi.com/comfort>

