



# B and BI Series Float & Thermostatic Steam Trap

Cast Iron for Horizontal Installation, With Thermostatic Air Vent

For Pressures From Vacuum to 30 psig (2 bar)...Capacities to 8,900 lb/hr (4,037 kg/hr)

Steam Trapping and Steam Tracing Equipment

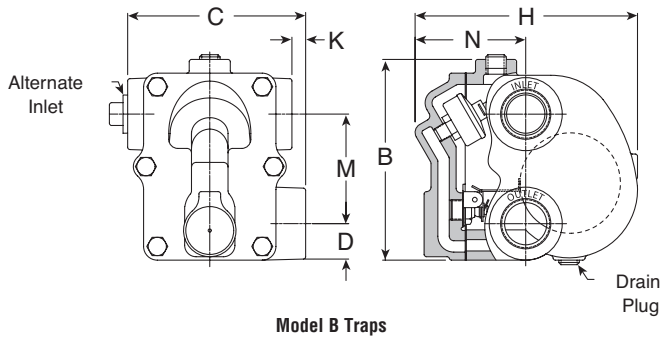

Model B Traps

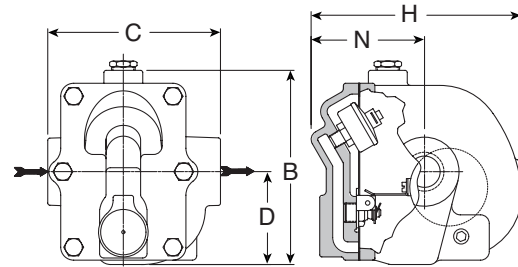

Model BI Traps

## Description

Armstrong B and BI Series F&T traps combine high standards of performance and long life with economy for heating service where continuous drainage with high air-venting capacity is required.

Because of the wide use of vacuum returns in systems of this type, the thermostatic air vent element is charged to give it the capability of compensated response to the pressure-temperature curve of steam at any pressure from less than 20" (500 mm) Hg vacuum to 30 psig (2 bar) gauge. B and BI Series F&T traps will vent air at slightly below steam temperature throughout this entire range of operation.

All B Series traps, except the 1/2" (15 mm) and 3/4" (20 mm), have inlet connections on both sides of the body to provide flexibility in piping. The BI Series F&T traps in sizes 1/2", 3/4" and 1" feature the convenience of in-line connections with the same internals as the B Series.

## Maximum Operating Conditions

Maximum allowable pressure (vessel design):

Model B2-B3: 125 psig @ 353°F (8.5 bar @ 178°C)

Model B4-B8: 175 psig @ 377°F (12 bar @ 191°C)

Maximum operating pressure:

15B, BI: 15 psig (1 bar) saturated steam

30B, BI: 30 psig (2 bar) saturated steam

**NOTE:** Cast iron traps should not be used in systems where excessive hydraulic or thermal shock are present.

## Connections

Screwed NPT and BSPT

## Materials

Body and cap:

ASTM A48 Class 30

Internals:

All stainless steel—304

Valve:

Stainless steel—303 or 440

Seat:

Stainless steel—303 (ASTM A582)

Stainless steel—440F in 1-1/2" and 2"

Thermostatic air vent:

Stainless steel and bronze with phosphor bronze bellows, caged in stainless steel

## Options

Integral vacuum breaker. Add suffix VB to model number.

**CAUTION:** Do not use a conventional vacuum breaker open to the atmosphere in any system that incorporates a mechanical return system that carries pressure less than atmospheric pressure. This includes all return systems designated as vacuum returns, variable vacuum returns or subatmospheric returns. If a vacuum breaker must be installed in such a system, it should be of the type that is loaded to open only when the vacuum reaches a calibrated level well in excess of the design characteristics of the system.

## Specification

Float and thermostatic steam trap, type ... in cast iron, with thermostatic air vent.

For a fully detailed certified drawing, refer to CD #1167.

## How to Order

Pressure	Model	Connection Size	Option
15	B	2	VB
15 30	B = Standard Connection  BI = In-line Connection	*2 = 1/2" *3 = 3/4" 4 = 1" 5 = 1-1/4" 6 = 1-1/2" 8 = 2"  2 = 1/2" 3 = 3/4" 4 = 1"	VB = Vacuum Breaker

\*No alternate inlet available.

## B and BI Series Traps

Trap Series	B Model						BI Model					
	in	mm	in	mm	in	mm	in	mm				
Pipe Connections	1/2, 3/4	15, 20	1	25	1-1/4	32	1-1/2	40	2	50	1/2, 3/4, 1	15, 20, 25
"B" (Height)	4-7/8	124	5-1/2	140	5-1/2	140	7-7/16	189	9-5/8	244	5-5/8	143
"C" (Face to Face)	3-7/8	98	4-7/8	124	4-5/8	117	5-3/4	146	7-5/8	194	5	127
"D" (Bottom to C)	7/8	22.2	1	25.4	1-7/32	31.0	1-7/16	36.5	1-11/16	42.9	2-11/16	68
"H" (Width)	5-3/8	137	6	152	7-3/4	197	8-7/16	214	11-5/8	295	6-5/8	168
"K" (Connection Offset)	1/8	3.2	3/8	9.5	—	—	—	—	—	—	—	—
"M" (C to C)	2-3/4	69.8	3	76.2	3	76.2	4-3/16	106	6	152	—	—
"N" (Top to C)	2-9/16	65.1	3	76.2	3-3/8	85.7	3-3/4	95.2	5	127	3-9/32	83
Weight lb (kg)	6 (2.7)		8-1/2 (3.9)		11 (5.0)		19 (8.6)		40 (18.1)		9-3/4 (4.4)	

NOTE: Cast iron traps should not be used in systems where excessive hydraulic or thermal shock are present.

Designs, materials, weights and performance ratings are approximate and subject to change without notice. Visit [www.armstronginternational.com](http://www.armstronginternational.com) for up-to-date information.

# B and BI Series Float & Thermostatic Steam Trap

Cast Iron for Horizontal Installation, With Thermostatic Air Vent

For Pressures From Vacuum to 30 psig (2 bar)...Capacities to 8,900 lb/hr (4,037 kg/hr)



Steam Trapping and  
Steam Trapping Equipment

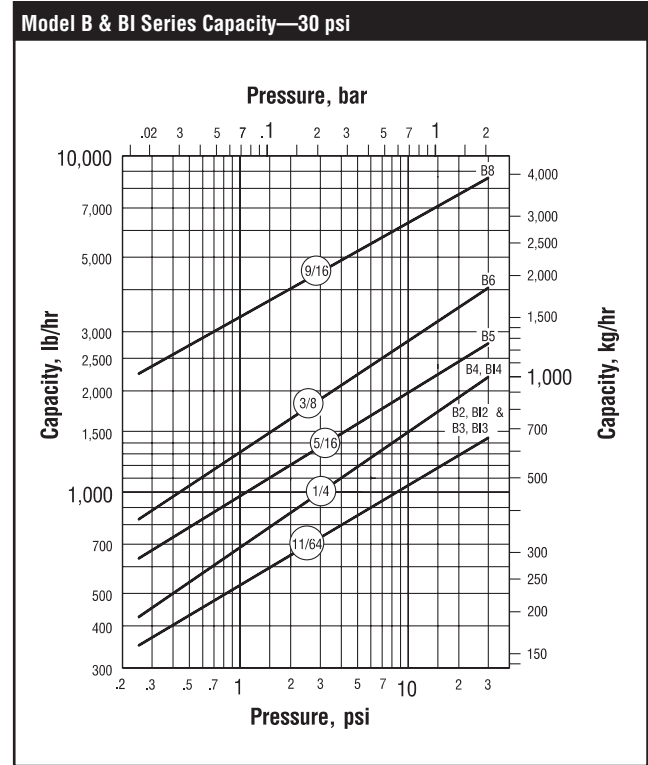
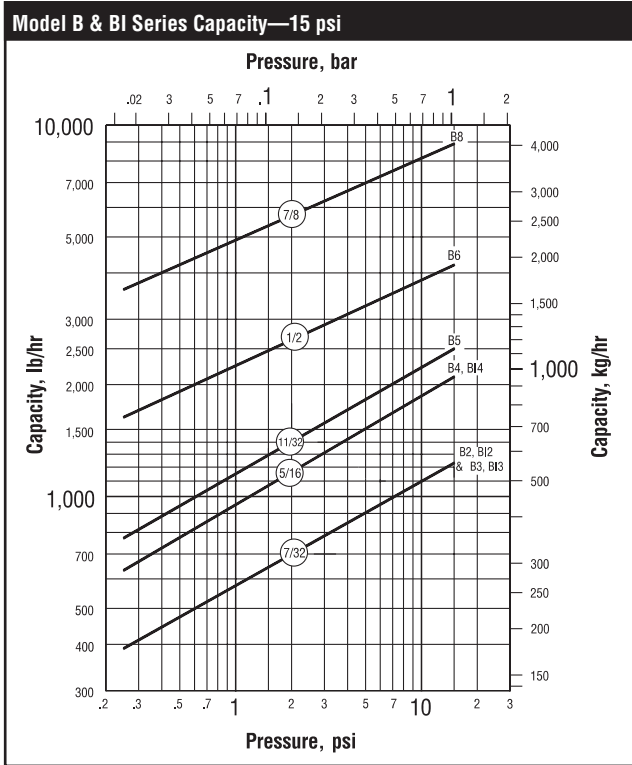

## Options

### Vacuum Breakers 3/8" (10 mm) and 1/2" (15 mm) NPT

Many times, condensate will be retained ahead of steam traps because of the presence of a vacuum. To break a vacuum, air must be introduced into the system by means of a vacuum breaker.

For maximum protection against freezing and water hammer in condensing equipment under modulated control, vacuum breakers are recommended. Armstrong B and BI Series F&T traps are available with integral vacuum breakers. Maximum pressure is 150 psig (10 bar).

Vacuum Breakers				
Size	in	mm	in	mm
		1/2 NPT	15 3/8	NPT
"B" Pipe Connections	3/8 NPT	10	1/4 NPT	6
"C" Height	1-1/4	32	1-3/32	28
"D" Width	7/8 Hex	22 Hex	11/16 Hex	17 Hex

