

SPECIFICATIONS

FIGURE 5715 - 5730

API 594 CHECK VALVES



CARBON STEEL, BOLTED BONNET, ASME CLASSES 150 & 300

FEATURES

- Full opening disc design
- Internal hinge pin
- API trim 8

Product Specifications	
Wall Thickness	API 600
Pressure-Temperature Rating	ANSI B16.34
Pressure Testing	API 598
Face to Face	ANSI B16.10
End Flanges	ANSI B16.5
Material	ASTM



FIGURE NUMBER MATRIX

FNW			
BODY MATERIAL	VALVE TYPE	CLASS	SIZE
5 = WCB	7 = Swing	15 = 150#	K = 2 12 = 12
	Check	30 = 300#	L = 2-1/2 14 = 14
			M = 3 16 = 16
			P = 4 18 = 18
			U = 6 20 = 20
			X = 8 24 = 24
			10 = 10

SPECIFICATIONS

FIGURE 5715 - 5730
API 594 CHECK VALVES



CARBON STEEL, BOLTED BONNET, ASME CLASSES 150 & 300

PART MATERIALS

No.	Part	Material
1	Body	ASTM A 216 GR. WCB
2	Body Seat	ASTM A 216 GR. WCB + ST - 6
3	Disc	ASTM A 216 GR. WCB + 13% CR. Facing
4	Washer	ASTM A 276 Type SS410
5	Disc Nut / Lock Nut	ASTM A 193 GR.B7
6	Hinge Pin	ASTM A 276 Type SS410
7	Hinge	ASTM A 216 GR. WCB
8	Guide Bushing	ASTM A 216 GR. WCB
9	Body Gasket	Spiral Wound SS 304 + Graphite Filler
10	Cover	ASTM A 216 GR. WCB
11	Body Stud & Nut	ASTM A 193 GR.B7 ASTM A 194 GR 2H
12	Name Plate	Stainless Steel
13	Stopper Pin	ASTM A 276 Type SS410
14	Hex Bolt	ASTM A 193 GR.B7
15	Spring Washer	Carbon Steel

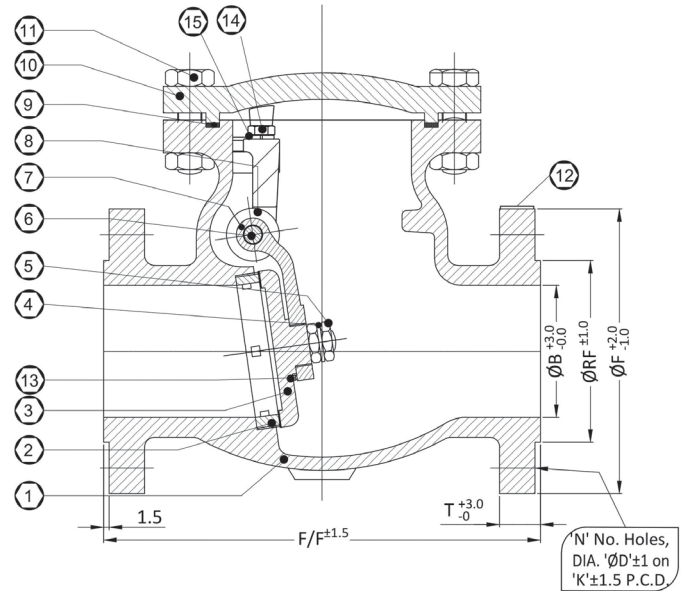

SPECIFICATIONS

FIGURE 5715

API 594 CHECK VALVES



CARBON STEEL, BOLTED BONNET, ASME CLASS 150

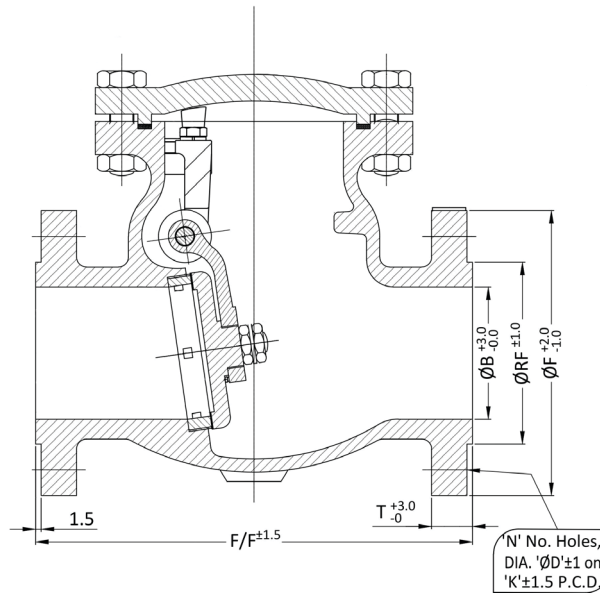

DIMENSIONS (IN.)

Size	F/F	ØB	ØF	T	ØRF	N	ØD	K
2	8.00	2.00	5.98	0.62	3.62	4	0.75	4.75
2-1/2	8.50	2.50	7.01	0.68	4.12	4	0.75	5.50
3	9.50	3.00	7.48	0.75	5.00	4	0.75	6.00
4	11.50	4.00	9.02	0.94	6.19	8	0.75	7.50
6	14.00	6.00	10.98	0.99	8.50	8	0.88	9.50
8	19.50	8.00	13.50	1.12	10.62	8	0.88	11.75
10	24.50	10.00	15.98	1.18	12.75	12	1.00	14.25
12	27.50	12.00	19.02	1.25	15.00	12	1.00	17.00
14	31.00	13.25	20.98	1.37	16.25	12	1.13	18.75
16	34.00	15.25	23.50	1.44	18.50	16	1.13	21.25
18	38.50	17.25	25.00	1.56	21.00	16	1.25	22.75
20	38.50	19.25	27.28	1.68	23.00	20	1.25	25.00
24	51.00	23.25	32.01	1.87	27.25	20	1.38	29.50

SPECIFICATIONS

FIGURE 5730

API 594 CHECK VALVES



CARBON STEEL, BOLTED BONNET, ASME CLASS 300

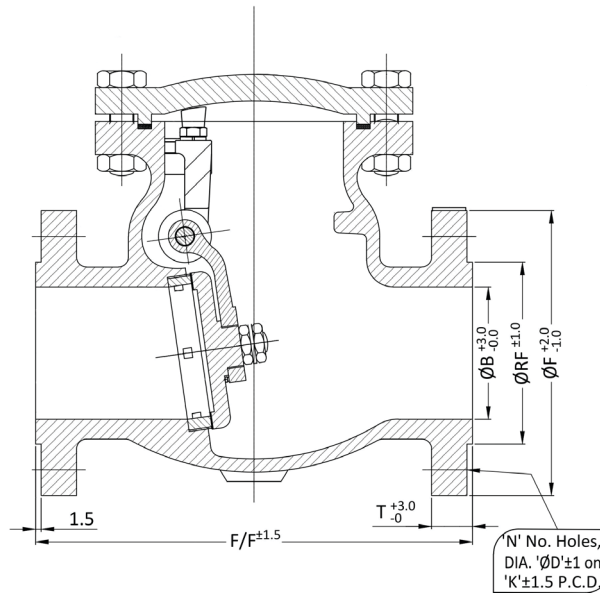

DIMENSIONS (IN.)

Size	F/F	ØB	ØF	T	ØRF	N	ØD	K
2	10.50	2.00	6.50	0.87	3.62	8	0.75	5.00
2-1/2	11.50	2.50	7.50	1.00	4.12	8	0.88	5.88
3	12.50	3.00	8.25	1.12	5.00	8	0.88	6.62
4	14.00	4.00	10.00	1.25	6.19	8	0.88	7.88
6	17.50	6.00	12.50	1.44	8.50	12	0.88	10.62
8	21.00	8.00	15.00	1.62	10.62	12	1.00	13.00
10	24.50	10.00	17.50	1.87	12.75	16	1.13	15.25
12	28.00	12.00	20.50	2.00	15.00	16	1.25	17.75
14	33.00	13.25	23.00	2.12	16.25	20	1.25	20.25
16	34.00	15.25	25.50	2.25	18.50	20	1.38	22.50
18	38.50	17.00	28.00	2.37	21.00	24	1.38	24.75
20	40.00	19.00	30.50	2.50	23.00	24	1.38	27.00
24	53.00	23.00	36.00	2.75	27.25	24	1.63	32.00