



## Air Handlers



### **DRF1PB**

Motor: PSC

Airflow Stages: Single-Stage

Expansion Device: Thermal Expansion Valve (TXV)

Efficiencies: 13.4 to 14.3 SEER2

Refrigerant Type: R-454B



## Table of Contents

Features and Benefits .....	3
Model Number Identification .....	4
Dimensional Data .....	5
Unit Dimensions & Weights .....	6
Airflow Performance Data .....	7-8
Electrical Data .....	9-10
Limited Warranty .....	12

## Features and Benefits

- **Quiet Operation<sup>1</sup>:** Provided by a cabinet construction with 1.0 inch of foil faced insulation for quieter sound characteristics
- **Front or Bottom Return with Aluminum Indoor Coil Design:** Are constructed of aluminum fins bonded to internally grooved aluminum tubing and are more corrosion resistant
- **Rugged Steel Cabinet Construction:** Designed for added strength and versatility
- **Most Compact Unit Design Available:** All standard air handler models are only 36" [915mm] in height
- **Field-installed Auxiliary Heater Kits:** Provide exact heat for indoor comfort and include circuit breakers which meet UL and cUL requirements for service disconnect
- **Less than 2% Cabinet Air Leakage at 1-inch H<sub>2</sub>O:** When tested in accordance with ASHRAE Standard 193
- **Designing for Sustainability with Low GWP:** For 2025, the Environmental Protection Agency (EPA) has set a global warming potential (GWP) limit of 700 for refrigerant used in heating and cooling systems. This new requirement will result in a 78%<sup>2</sup> lower GWP than previous-generation refrigerants — with only minimal changes to system installation. For us, this is another step toward our continued sustainability goal of reducing greenhouse gas emissions, while still delivering an exceptional level of energy efficient, dependable comfort
- **Refrigerant Detection System<sup>3</sup>:** An integrated one-box, patented design featuring the A2L sensor and mitigation board, offering easier commissioning with a single component and simplified wiring configuration, compatibility with any 24V thermostat application and system protection by automatically pausing outdoor unit operation — if excess refrigerant is detected

[ ] Designates Metric Conversions

<sup>1</sup>Based on manufacturer's air handler offering, and the product's airflow stages, motor type and cabinet insulation. Sound levels are also dependent on air handler location and installation.

<sup>2</sup>When comparing the GWP of A2L refrigerants to R-410A refrigerant.

<sup>3</sup>Factory or field installed in the furnace coil or air handler and is applicable to the complete heating and cooling system featuring Low GWP Refrigerant (A2L).

# Air Handlers

<u>DR</u>	<u>F</u>	<u>1</u>	<u>P</u>	<u>B</u>	<u>18</u>	<u>21</u>	<u>A</u>	<u>S</u>	<u>T</u>	<u>S</u>	<u>N</u>	<u>J</u>	<u>B</u>	<u>0</u>	<u>417</u>
Brand	Product Category	Stages Of Airflow	Motor Type	Refrigerant	Capacity	Width	Major Series	Efficiency	Metering	Coil Series	Controls	Voltage	Disconnect	Factory Heat	Option Code
Durastar	F - Front Return	1 - 1-Stage	P - PSC	B - R-454B	18 - 18,000 [5.28 kW] 24 - 24,000 [7.03 kW] 30 - 30,000 [8.79 kW] 36 - 36,000 [10.55 kW]	21 - 21" 24 - 24.5" 1st Design	A - 1st Design	S - Standard	T - TXV	S - Slab	N - Non-Communicating	J - 208-240/1/60	B - Breaker N - None	0 - No Heat 3 - 3 kW 5 - 5 kW 8 - 8 kW 10 - 10 kW	Blank - Factory-Installed Sensor L - Less A2L Sensor F - Float Switch E - Less Sensor w/Float Switch

Available Models			
DRF1PB1821ASTSNJB3	DRF1PB1821ASTSNJB3F	DRF1PB1821ASTSNJB3L	DRF1PB1821ASTSNJB3E
DRF1PB1821ASTSNJB5	DRF1PB1821ASTSNJB5F	DRF1PB1821ASTSNJB5L	DRF1PB1821ASTSNJB5E
DRF1PB1821ASTSNJB8	DRF1PB1821ASTSNJB8F	DRF1PB1821ASTSNJB8L	DRF1PB1821ASTSNJB8E
DRF1PB1821ASTSNJN0	DRF1PB1821ASTSNJN0F	DRF1PB1821ASTSNJN0L	DRF1PB1821ASTSNJN0E
DRF1PB2421ASTSNJB3	DRF1PB2421ASTSNJB3F	DRF1PB2421ASTSNJB3L	DRF1PB2421ASTSNJB3E
DRF1PB2421ASTSNJB5	DRF1PB2421ASTSNJB5F	DRF1PB2421ASTSNJB5L	DRF1PB2421ASTSNJB5E
DRF1PB2421ASTSNJB8	DRF1PB2421ASTSNJB8F	DRF1PB2421ASTSNJB8L	DRF1PB2421ASTSNJB8E
DRF1PB2421ASTSNJB1	DRF1PB2421ASTSNJB1F	DRF1PB2421ASTSNJB1L	DRF1PB2421ASTSNJB1E
DRF1PB2421ASTSNJN0	DRF1PB2421ASTSNJN0F	DRF1PB2421ASTSNJN0L	DRF1PB2421ASTSNJN0E
DRF1PB3024ASTSNJB3	DRF1PB3024ASTSNJB3F	DRF1PB3024ASTSNJB3L	DRF1PB3024ASTSNJB3E
DRF1PB3024ASTSNJB5	DRF1PB3024ASTSNJB5F	DRF1PB3024ASTSNJB5L	DRF1PB3024ASTSNJB5E
DRF1PB3024ASTSNJB8	DRF1PB3024ASTSNJB8F	DRF1PB3024ASTSNJB8L	DRF1PB3024ASTSNJB8E
DRF1PB3024ASTSNJB1	DRF1PB3024ASTSNJB1F	DRF1PB3024ASTSNJB1L	DRF1PB3024ASTSNJB1E
DRF1PB3024ASTSNJN0	DRF1PB3024ASTSNJN0F	DRF1PB3024ASTSNJN0L	DRF1PB3024ASTSNJN0E
DRF1PB3624ASTSNJB3	DRF1PB3624ASTSNJB3F	DRF1PB3624ASTSNJB3L	DRF1PB3624ASTSNJB3E
DRF1PB3624ASTSNJB5	DRF1PB3624ASTSNJB5F	DRF1PB3624ASTSNJB5L	DRF1PB3624ASTSNJB5E
DRF1PB3624ASTSNJB8	DRF1PB3624ASTSNJB8F	DRF1PB3624ASTSNJB8L	DRF1PB3624ASTSNJB8E
DRF1PB3624ASTSNJB1	DRF1PB3624ASTSNJB1F	DRF1PB3624ASTSNJB1L	DRF1PB3624ASTSNJB1E
DRF1PB3624ASTSNJN0	DRF1PB3624ASTSNJN0F	DRF1PB3624ASTSNJN0L	DRF1PB3624ASTSNJN0E

Standard Equipment
The most compact unit design available, all standard heat air handler models only 36" [915 mm]
Rugged wall steel cabinet construction, designed for added strength and versatility
1.0" foil faced insulation for excellent thermal and sound performance
Four leg blower motor mount
Traditional open wire element design for heat applications
Indoor coil design provides low air side pressure drop, high performance and extremely compact size
Coils are constructed of aluminum fins and internally grooved aluminum tubing
Molded polymer corrosion resistant condensate drain pan is provided for all indoor coils
Connection point for high voltage wiring is inside the air handler cabinet. Low voltage connection is made on the outside of the air handler cabinet
Concentric knockouts are provided for power connection to cabinet. Installer may pull desired hole size up to 1-3/8 inches [35 mm] for 7/8 inch [22 mm] conduit

[ ] Designates Metric Conversions

# Unit Dimensions

NOTE: 24" [610 mm] CLEARANCE REQUIRED IN FRONT OF UNIT FOR FILTER AND COIL MAINTENANCE

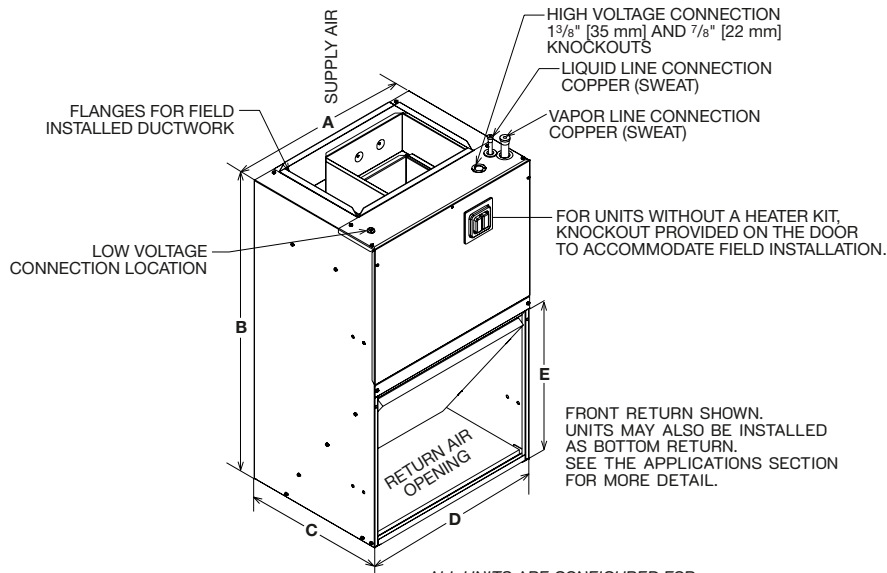

FRONT RETURN SHOWN. UNITS MAY ALSO BE INSTALLED AS BOTTOM RETURN. SEE THE APPLICATIONS SECTION FOR MORE DETAIL.

ALL UNITS ARE CONFIGURED FOR VERTICAL UPFLOW. UNITS CANNOT BE INSTALLED IN ANY OTHER CONFIGURATION.

## Return Air Opening Dimensions

Model Cabinet Size	Return Air Opening Width (Inches)	Return Air Opening Depth/Length (Inches)
21	19 <sup>3</sup> / <sub>8</sub>	19 <sup>3</sup> / <sub>4</sub>
24	22 <sup>7</sup> / <sub>8</sub>	19 <sup>3</sup> / <sub>4</sub>

Illustration  
ST-A1358-02-01

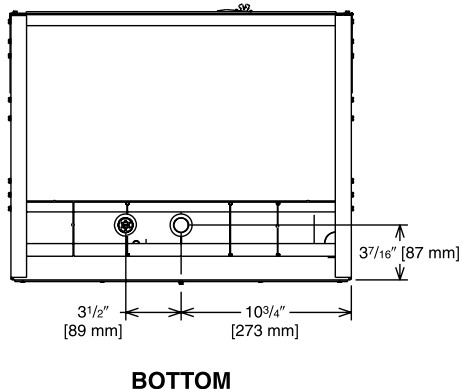
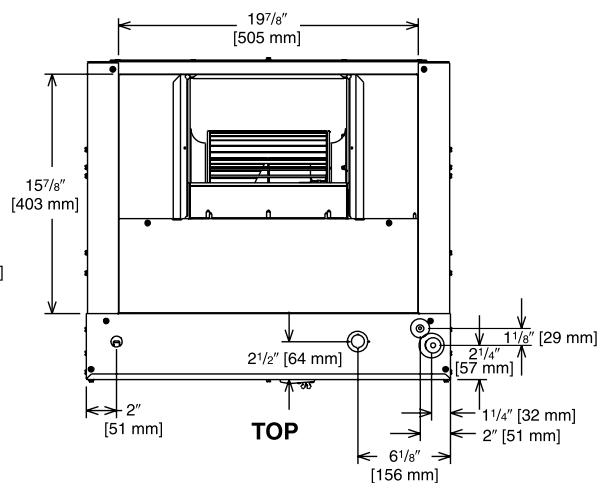
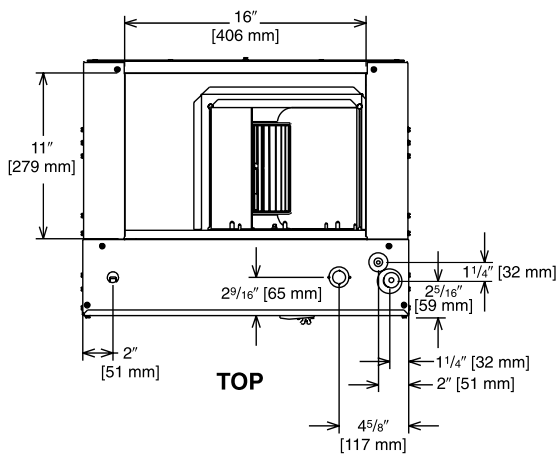

**1 1/2 & 2 TON [5.28 & 7.03 kW] MODELS**

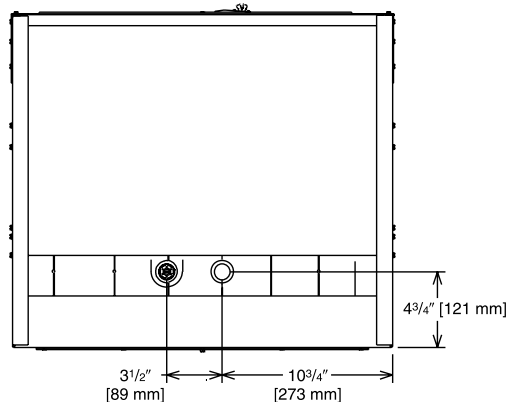

**2 1/2 & 3 TON [8.79 & 10.6 kW] MODELS**

Illustration  
ST-A1358-03-00

## Unit Dimensions & Weights

Model	(A) Unit Width In. [mm]	(B) Unit Height In. [mm]	(C) Unit Depth In. [mm]	(D) Return Air Opening Width In. [mm]	(E) Return Air Opening Height In. [mm]	Filter Size in. x in. x in. [mm x mm x mm]	Air Flow CFM (Nom.) [L/s]		Unit Weight/ Shipping Weight (Lbs.) [kg]
							Low	High	
DRF1PB1821	21½ [546.1]	36 [914.4]	17 [431.8]	20 [508.0]	17 <sup>7</sup> / <sub>16</sub> [442.9]	20 X 20 X 1 [508 X 508 X 25.4]	600 [283]	—	80 [36] / 90 [41]
DRF1PB2421	21½ [546.1]	36 [914.4]	17 [431.8]	20 [508.0]	17 <sup>7</sup> / <sub>16</sub> [442.9]	20 X 20 X 1 [508 X 508 X 25.4]	800 [378]	—	80 [36] / 90 [41]
DRF1PB3024	24 [609.6]	36 [914.4]	21 [533.4]	23 [584.2]	21 <sup>3</sup> / <sub>8</sub> [542.9]	20 X 25 X 1 [508 X 635 X 25.4]	1000 [472]	—	95 [43] x 105 [48]
DRF1PB3624	24 [609.6]	36 [914.4]	21 [533.4]	23 [584.2]	21 <sup>3</sup> / <sub>8</sub> [542.9]	20 X 25 X 1 [508 X 635 X 25.4]	1200 [566]	—	95 [43] x 105 [48]

[ ] Designates Metric Conversions

## Airflow Performance

**Airflow performance data is based on cooling performance with a coil and no filter in place.** Select performance table for appropriate unit size, voltage and number of electric heaters to be used. Make sure external static applied to unit allows operation within the minimum and maximum limits shown in

table below for both cooling and electric heat operation. For optimum blower performance, operate the unit in the .3 [8 mm] to .7 inches [18 mm] W.C. external static range. Units with coils should be applied with a minimum of .1 inch [3 mm] W.C. external static range.

## Airflow Operating Limits

Model Cabinet Size	21		24	
Cooling BTUH x 1,000 Cooling Tons Nominal	-18 1.5	-24 2	-30 2.5	-36 3
Heat Pump or Air Conditioning Maximum Heat/Cool CFM [L/s] (37.5 CFM [18 L/s]/1,000 BTUH) (450 CFM [212 L/s]/Ton Nominal)	675 [319]	900 [425]	1125 [531]	1350 [637]
Heat Pump or Air Conditioning Nominal Heat/Cool CFM [L/s] (33.3 CFM [16 L/s]/1,000 BTUH) (400 CFM [189 L/s]/Ton Nominal)	600 [283]	800 [378]	1000 [472]	1200 [566]
Heat Pump or Air Conditioning Minimum Heat/Cool CFM [L/s] (30.0 CFM [14 L/s]/1,255 BTUH) (360 CFM [170 L/s]/Ton Nominal)	540 [255]	720 [340]	900 [425]	1080 [510]
Maximum kW Electric Heating & Minimum Electric Heat CFM [L/s]	8 450 [212]	10 690 [326]	10 808 [381]	10 976 [461]
Maximum Electric Heat Rise °F [°C]	54 [12]	44 [7]	44 [7]	44 [7]

[ ] Designates Metric Conversions

### Airflow Performance Data – DRF1PB (PSC Motor)

Model/ Nominal Cooling Capacity	Manufacturer Recommended Airflow Range (Max./Min.) CFM	Blower Size/ Motor HP # of Speeds	Motor Speed From Factory	Motor Speed	PSC										
					CFM Dry Delivery/Filter/Heaters/RPM/Watts										
					External Static Pressure-Inches W.C.										
						0.10	0.20	0.30	0.40	0.50	0.60	0.70	0.80	0.90	1.00
DRF1PB18 1.5 tons	995/199	10x6 1/5 Hp 2 speed dual voltage	High	High	CFM	995	940	872	832	761	696	623	525	343	199
					RPM	937	957	974	987	1000	1018	1031	1052	1080	1103
					Watts	329	318	307	300	289	280	271	259	240	222
				Low	CFM	877	822	763	710	661	603	523	433	209	199
					RPM	851	880	905	925	946	964	995	1022	1072	1071
					Watts	244	234	226	219	212	204	193	183	156	154
DRF1PB24 2 Tons	1085/354	10x6 1/4 Hp 2 speed dual voltage	High	High	CFM	1085	1025	977	912	857	822	768	675	589	358
					RPM	1018	1030	1039	1047	1056	1065	1068	1083	1094	1123
					Watts	358	348	342	325	313	312	303	288	277	243
				Low	CFM	1058	1004	945	889	842	802	743	662	542	354
					RPM	1004	1018	1027	1037	1047	1049	1062	1075	1102	1117
					Watts	337	329	316	304	300	294	284	270	253	223
DRF1PB30 2.5 Tons	1411/359	10x8T 1/3 Hp 2 speed dual voltage	High	High	CFM	1411	1337	1294	1218	1143	1056	950	867	705	378
					RPM	1023	1036	1048	1057	1070	1082	1085	1075	1081	1116
					Watts	483	462	451	433	414	396	374	358	331	283
				Low	CFM	1266	1215	1160	1097	1028	945	870	758	605	359
					RPM	933	955	983	1005	1023	1042	1057	1075	1095	1121
					Watts	407	392	380	365	350	330	315	292	271	235
DRF1PB36 3 Tons	1363/1048	10x8T 1/2 Hp 2 speed dual voltage	High	High	CFM	1486	1425	1353	1307	1184	1110	1018	931	725	588
					RPM	1079	990	1091	1103	1115	1121	1114	838	1144	1125
					Watts	692	664	644	631	612	593	582	571	528	515
				Low	CFM	1399	1324	1276	1203	1115	1021	960	905	725	427
					RPM	1021	1036	1044	1057	1066	1077	1103	1110	1116	1128
					Watts	507	488	472	450	432	410	394	379	340	293

[ ] Designates Metric Conversions

## Electrical Data – Blower Motor Only – No Electric Heat DRF1PB

Model/Nominal Cooling Tons	Voltage	Phase	Hertz	HP [W]	RPM	Speeds	Circuit Amps.	Minimum Circuit Ampacity	Maximum Circuit Protector
DRF1PB1821	208/230	1	60	1/5 [149]	1075	2	1.9	3	15
DRF1PB2421	208/230	1	60	1/4 [149]	1075	2	1.9	3	15
DRF1PB3024	208/230	1	60	1/3 [249]	1075	2	2.7	4	15
DRF1PB3624	208/230	1	60	1/2 [373]	1075	2	2.7	4	15

\*Blower motors are all single phase motors.

## DRF1PB Electrical Data – with Electric Heat

Installation of the U.L. Listed original equipment manufacturer provided heater kits listed in the table below is recommended for all auxiliary heating requirements.

Cooling Capacity Tons	Model No.	Heater kW	PH/Hz	No. Elements - kW Per	(208/240V) Type Supply Circuit	Circuit Amps.	Motor Ampacity	Minimum Circuit Ampacity	Maximum Circuit Protection
DRF1PB18	RXHJ-21B/T03J-1	2.25/3.0	1/60	1-3.0	Single	10.8/12.5	1.9	16/18	20/20
	RXHJ-21B/T05J-1	3.6/4.8	1/60	1-4.8	Single	17.3/20.0	1.9	24/28	25/30
	RXHJ-21B/T08J-1	5.4/7.2	1/60	2-3.6	Single	26.0/30.0	1.9	35/40	35/40
DRF1PB24	RXHJ-21B/T03J-1	2.25/3.0	1/60	1-3.0	Single	10.8/12.5	1.9	16/18	20/20
	RXHJ-21B/T05J-1	3.6/4.8	1/60	1-4.8	Single	17.3/20.0	1.9	24/28	25/30
	RXHJ-21B/T08J-1	5.4/7.2	1/60	2-3.6	Single	26.0/30.0	1.9	35/40	35/40
	RXHJ-21B/T10J-1	7.2/9.6	1/60	2-4.8	Single	34.6/40.0	1.9	46/53	50/60
DRF1PB30	RXHJ-24B/T03J-1	2.25/3.0	1/60	1-3.0	Single	10.8/12.5	2.7	17/19	20/20
	RXHJ-24B/T05J-1	3.6/4.8	1/60	1-4.8	Single	17.3/20.0	2.7	25/29	25/30
	RXHJ-24B/T08J-1	5.4/7.2	1/60	2-3.6	Single	26.0/30.0	2.7	36/41	40/45
	RXHJ-24B/T10J-1	7.2/9.6	1/60	2-4.8	Single	34.6/40.0	2.7	47/54	50/60
DRF1PB36	RXHJ-24B/T03J-1	2.25/3.0	1/60	1-3.0	Single	10.8/12.5	2.7	17/19	20/20
	RXHJ-24B/T05J-1	3.6/4.8	1/60	1-4.8	Single	17.3/20.0	2.7	25/29	25/30
	RXHJ-24B/T08J-1	5.4/7.2	1/60	2-3.6	Single	26.0/30.0	2.7	36/41	40/45
	RXHJ-24B/T10J-1	7.2/9.6	1/60	2-4.8	Single	34.6/40.0	2.7	47/54	50/60

- Electric heater BTUH - (heater watts + motor watts) x 3.414 (see airflow table for motor watts.)
- J voltage (230V) single phase air handler is designed to be used with single or three phase.
- Supply circuit protective devices may be fused or "HACR" type circuit breakers.
- If non-standard fuse size is specified, use next size larger standard fuse size. Without the heater, bring only two leads to terminal block, cap, insulate and fully secure the third lead.
- Largest motor load is included in single circuit or circuit 1 of multiple circuits.
- Do not use 480 volts electrical heaters on 230 volts air handler.
- No electrical heating elements are permitted to be used with A Voltage (115V) air handler.

### Electrical Wiring: Power Wiring Grounding

- Field wiring must comply with the National Electrical Code.
- This product must be sufficiently grounded in accordance with (C.E.C. in Canada) and any applicable local ordinance. National Electrical Code (C.E.C. in Canada) and any applicable.
- Supply wiring must be 75°C minimum copper conductors only. Local ordinance.
- See electrical data for product Ampacity rating and Circuit.
- A grounding lug is provided. Protector requirement.

[ ] Designates Metric Conversions

## 16.0 Accessories-Kits-Parts

- **Drain Pan Over Flow Switch RXHK-A01** is used to detect condensate drain blockage and will shut down the outdoor unit in order to prevent structural damage to the surrounding structures of the air handler.

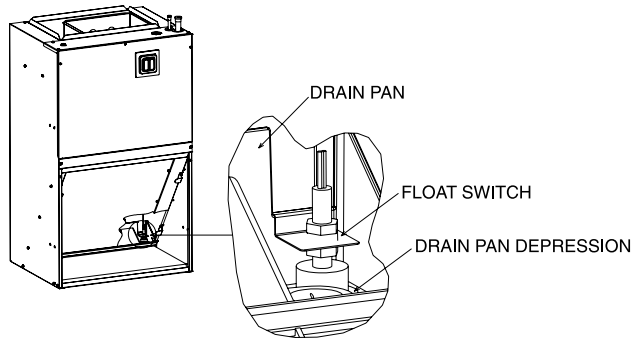

- **Bottom Return Conversion Kit RXHK-** is used to divert the return air from the factory standard front return to a bottom return.

Accessory Number	Indoor Unit
RXHK-B01	RF1PY-FR18
	RF1PY-FR24
RXHK-B02	RF1PY-FR30
	RF1PY-FR36

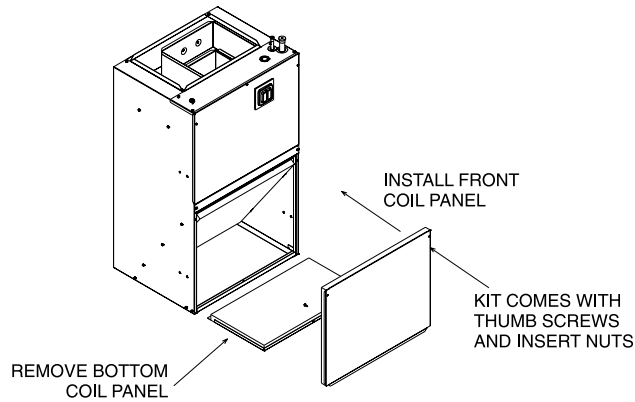

- **Louvered Cabinet Grill RXHK-** is used as decorative grill which covers the return air opening of the front return air handler.

Accessory Number	Indoor Unit
RXHK-C01	RF1PY-FR18
	RF1PY-FR24
RXHK-C02	RF1PY-FR30
	RF1PY-FR36

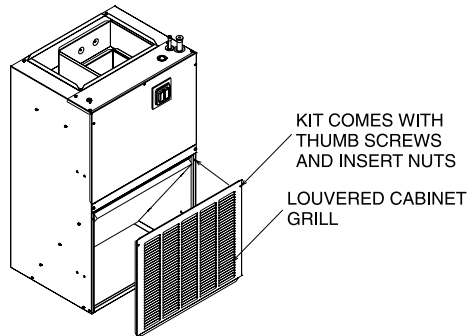

- **Decorative Wall Grill RXHK-D01** or **RXHK-D02** is used in applications where the air handler is installed in a closet or interior wall and allows adequate return air back to the unit. Please refer to RXHD-D01/RXHK-D02 installation instructions for complete dimensional information when selecting a decorative wall grill.

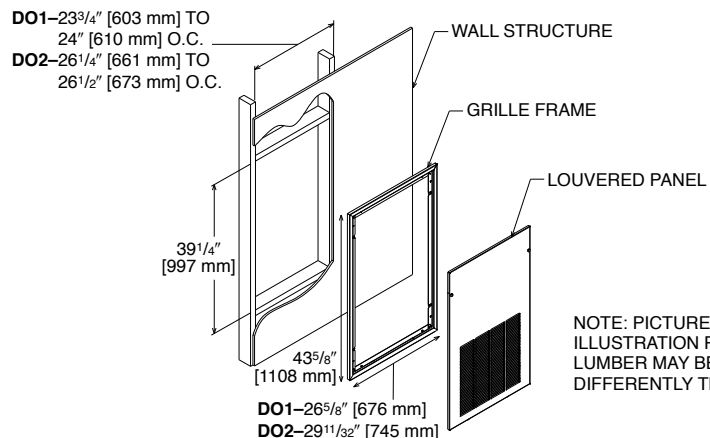

[ ] Designates Metric Conversions





**GENERAL TERMS OF LIMITED WARRANTY\***

Durastar will furnish a replacement for any part of this product which fails in normal use and service within the applicable periods stated, in accordance with the terms of the limited warranty.

Conditional Parts  
(Registration Required)..... Ten (10) Years

**\*For complete details of the Limited and Conditional Warranties, including applicable terms and conditions, contact your local contractor or the Manufacturer for a copy of the product warranty certificate.**

**Before proceeding with installation, refer to installation instructions packaged with each model, as well as complying with all Federal, State, Provincial, and Local codes, regulations, and practices.**



*"In keeping with its policy of continuous progress and product improvement, Durastar reserves the right to make changes without notice."*