

SPECIFICATIONS

# FIGURE 791C

## BUTTERFLY VALVE



### GROOVED BUTTERFLY VALVE W/ TAMPER SWITCH (NORMALLY CLOSED)

#### FEATURES

- Available sizes: 2"–8"
- Connection ends: Groove to AWWA C606
- Designed for fire protection services
- Includes a weatherproof actuator
- Working pressure: 300 psi
- Temperature range: 32°F–175°F
- UL/ULc and FM approved
- Coating: Fusion bonded epoxy coating

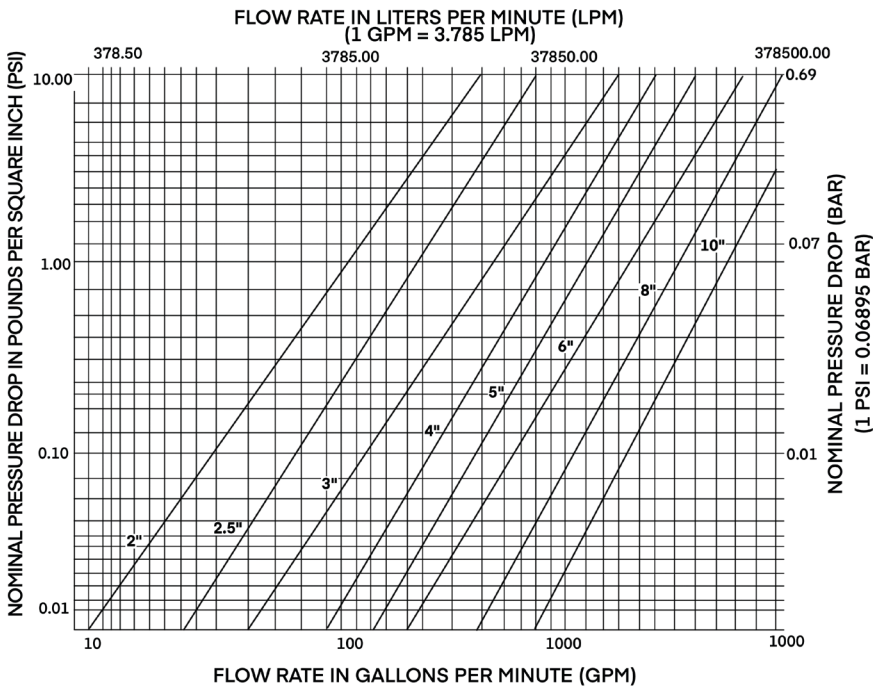
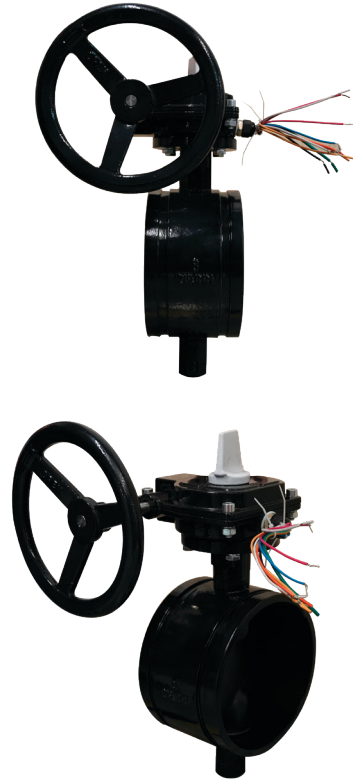

# FIGURE 791C

## BUTTERFLY VALVE



### GROOVED BUTTERFLY VALVE W/ TAMPER SWITCH (NORMALLY CLOSED)

#### PARTS DIAGRAM

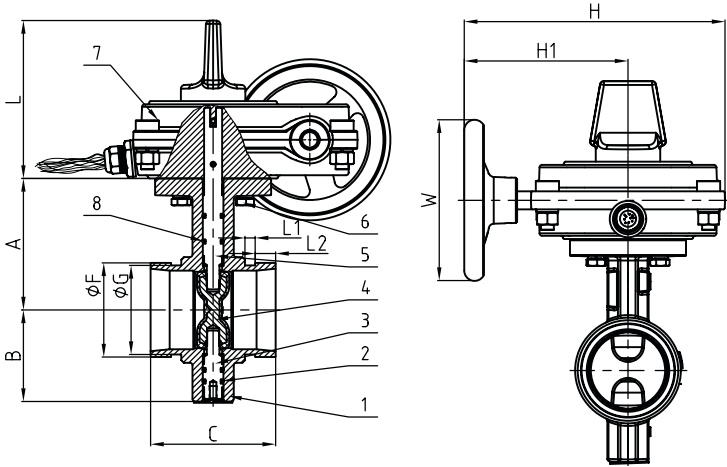

#### PART MATERIALS

Part No.	Part	Material/Specification
1	Body	ASTM A536, 65-45-12
2	O-Ring	NBR
3	Stub Shaft	AISI 431
4	Disc	ASTM A536, 65-45-12+EPDM
5	Drive Shaft	AISI 431
6	Hex Nut	Carbon Steel Zinc plated
7	Signal Gearbox Body	ASTM A536, 65-45-12
8	O-Ring	NBR

#### REFERENCE CHART

Catalog Number	DN		Dimensions (in.)										
	in.	mm	A	B	C	F	G	L	L1	L2	H1	H	W
FNW791CK	2	50	3.50	2.56	3.19	2.37	2.25	4.82	0.31	0.63	5.00	7.96	4.92
FNW791CL	2.5	65	4.02	2.80	3.82	2.87	2.72	4.82	0.31	0.63	5.00	7.96	4.92
FNW791CM	3	80	4.29	3.19	3.82	3.50	3.34	4.82	0.31	0.63	5.00	7.96	4.92
FNW791CP	4	100	5.04	3.74	4.57	4.50	4.33	4.82	0.38	0.63	5.00	7.96	4.92
FNW791CU	6	150	6.02	5.24	5.83	6.63	6.46	4.82	0.38	0.63	5.49	8.46	8.86
FNW791CX	8	200	7.24	6.46	5.24	8.63	8.44	4.82	0.44	0.75	7.81	10.79	8.86

Note: Valve must not be installed with disc in full open position. Disc must be partly closed so that the disc is not protruding beyond the end of the valve body.

## INSTALLATION

Follow the latest grooved coupling manufacturer installation procedure for IPS dimension grooved couplings per ANSI/AWWA C606.

### Switch Wiring

- Valve has internal switches that operate from the CLOSED position.
- One switch has dual leads that are for connection to the SUPERVISORY circuit of an alarm panel. The other switch has single leads and is intended to be connected to the AUXILIARY equipment.
- Tuck unused leads into junction box.
- Follow building codes, local codes and NFPA 13, 71 and 72 during installation.

#### Signal description:

- Switch parameters:  
16A 1/2HP 125/250VAC
- Wiring diagram:

