



Smith-Blair  
a xylem brand

# SPECIFICATION

## TOP BOLT® WIDE RANGE COUPLING

### MODEL 421

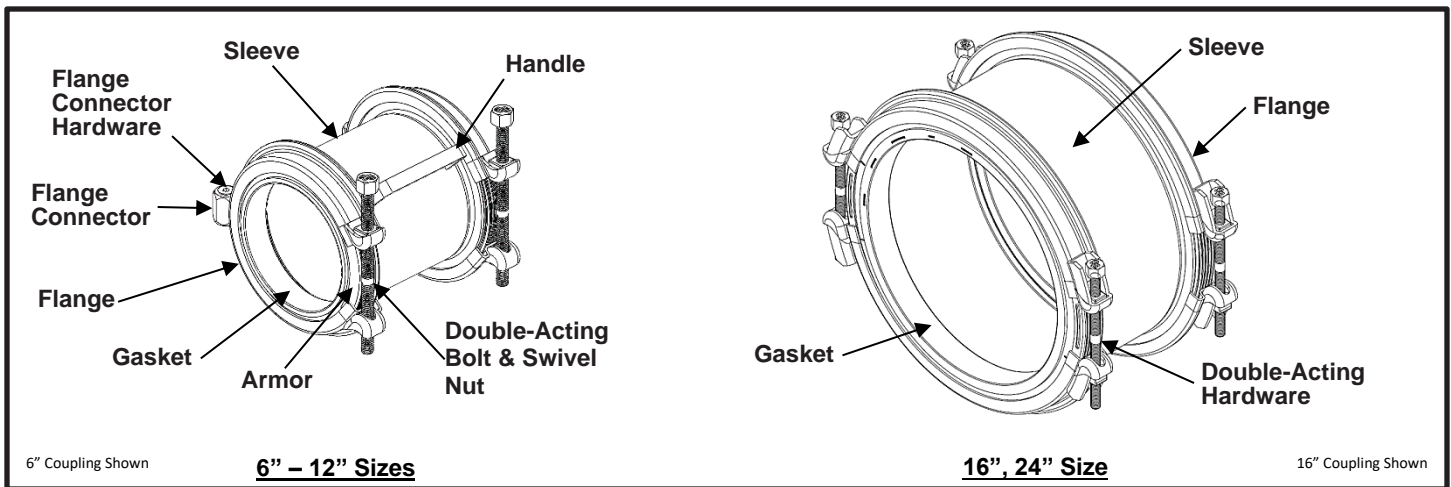

#### APPLICATIONS

- **Typical Uses**
  - Joining plain-end pipe of same outside diameters
  - Joining plain-end pipe of different outside diameters within the same nominal pipe size
  - Replace split or excessively damaged pipe
- **Standard Pipe Sizes**
  - 2" to 12" nominal
  - 10", 12", 16" & 24" Oversize
  - 16", 24" nominal
- **Type of Pipe**
  - Carbon Steel, Stainless Steel, Ductile Iron, Asbestos Cement, PVC, Copper Tube
- **Working Pressure / Test Pressure**
  - 2" – 12", 16" = 260 psi / 390 psi
  - 24" DI Size Pipe = 260 psi / 390 psi
  - 24" IPS Size Pipe = 150 psi / 225 psi
  - 16" & 24" OS = 200 psi / 300 psi

#### MATERIALS

- **Flange**
  - Carbon Steel per ASTM A283C, A285A or A36
  - Flexi-Coat® fusion bonded epoxy finish
- **Sleeve**
  - Carbon Steel per ASTM A283C or A36
  - Flexi-Coat fusion bonded epoxy finish
- **Gasket**
  - Nitrile (Buna-N) per ASTM D2000
  - Compounded to resist water, oil, acids, alkalies, most (aliphatic) hydrocarbon fluids, and many other chemicals
  - Temperature range: -20°F to +180°F
- **Armor**
  - Type 304 Stainless Steel quarter-hard per ASTM A240



Smith-Blair  
a xylem brand

# SPECIFICATION

## TOP BOLT® WIDE RANGE COUPLING

### MODEL 421

---

- **Standard Hardware Size(s): 2" – 4"**
  - **Bolt**
    - Type 304 Stainless Steel
    - Epoxy coated
    - 9/16" - 12 UNC, Swivel Head Bolt with Rolled Threads
  - **Flange Connector Hardware**
    - Type 304 Stainless Steel
    - 1/2" – 13 UNC, Countersunk Allen Head
  - **Swivel Washer**
    - Type 304 Stainless Steel
    - 9/16"
  - **Steel Washer**
    - Type 304 Stainless Steel
    - 9/16"
  - **Nylon Washer**
    - Nylon 6/6
    - 9/16"
  - **Nut**
    - Type 304 Stainless Steel or equivalent
    - 9/16" - 12 UNC
    - Fluoropolymer Coated
- **Double-Acting Hardware Size(s): 6" – 24" OS**
  - **Bolt**
    - Type 304 Stainless Steel
    - Anti-Gall Coating
    - 5/8" - 11 UNC Left and Right Hand Threaded Stud with Rolled Threads
    - Standard 5/8" Heavy Hex Cap Nut welded to stud
  - **Tapped Swivel Nuts**
    - Type 304 Stainless Steel or equivalent
    - Fluoropolymer Coated
    - (1) Left Hand tapped and (1) Right Hand Tapped

#### LISTINGS

- Certified to NSF/ANSI 61 and NSF/ANSI 372
- Meets applicable portions of AWWA C219
- Flexi-Coat Fusion-Bonded Epoxy Coating meets requirements of AWWA C213

#### OPTIONS

- Anode connector for cathodic protection
- Chloramine resistant EPDM gasket
- Pipe stops



*Smith-Blair*  
a xylem brand

# SPECIFICATION

## TOP BOLT® WIDE RANGE COUPLING

### MODEL 421

---

#### NOTES

- Xylem, Smith-Blair, SB stylized, Top Bolt and Flexi-Coat are registered trademarks of Xylem, Inc., or one of its subsidiaries.
- These product specifications were correct at the time of publication and are subject to change without notice
- See the Smith-Blair website for part numbers and ordering information
- See the Smith-Blair website for warranty information
- See the Smith-Blair website for corrosion notice

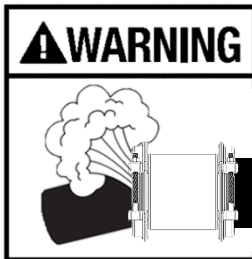

**THIS PRODUCT DOES NOT RESTRAIN PIPE MOVEMENT.** Proper anchoring is required to prevent pipe pullout. Failure to anchor or improper anchoring can result in dangerous pipe content escape, property damage, serious injury, or death. Read the product installation instructions prior to installing this product.

30 Globe Ave, Texarkana, AR 71854  
Ph: 870-773-5127 • Fax: 870-773-5212  
Toll-Free Numbers: Ph: 800-643-9705 • Fax: 800-648-6792

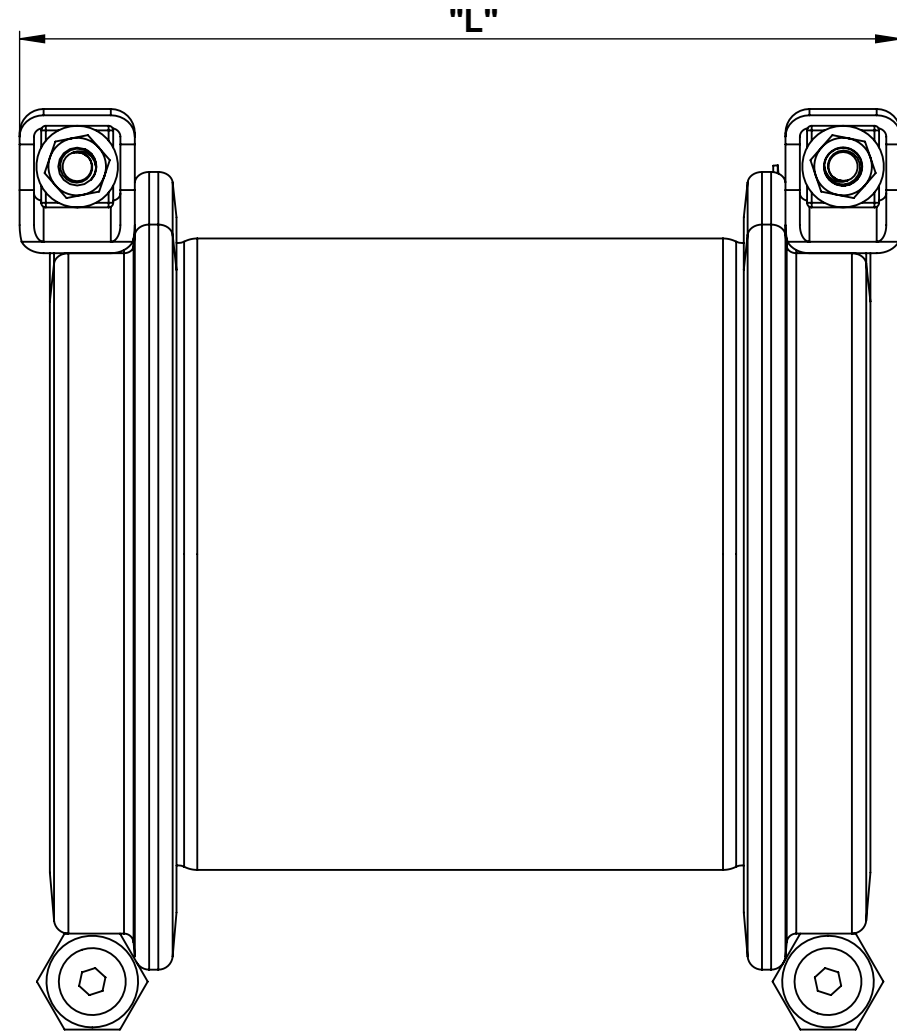
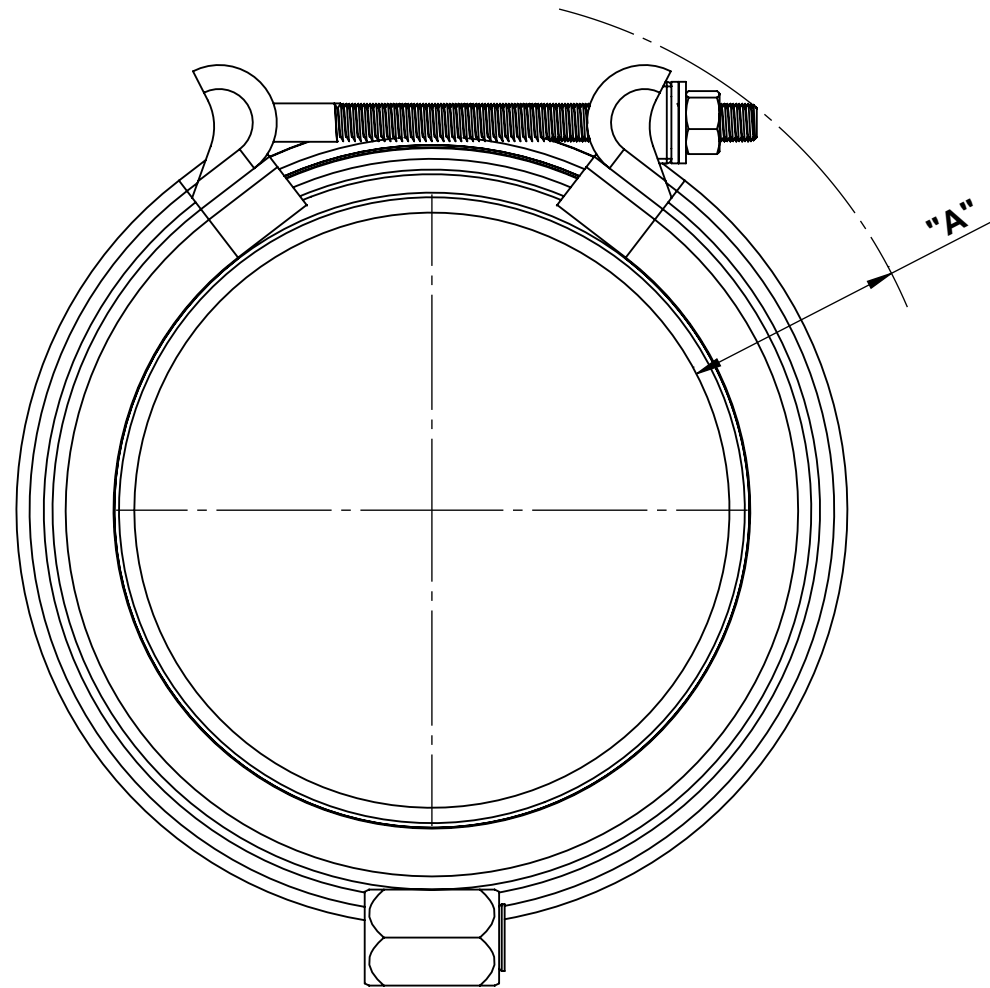

## 2"-4" **STANDARD COUPLING**

**NOTES:**

1. SEE CATALOG FOR PART NUMBERS AND RANGES
2. 4" COUPLING SHOWN OTHER SIZES SIMILAR

NOMINAL SIZE (IN)	A		L	BOXED WEIGHT (LBS)
	OPEN	CLOSED		
2	3.50	5.00 Max	7.5	8
3	3.50	5.00 Max	9.5	11
4	3.50	5.00 Max	9.75	19

### WRENCH SIZE CHART

NUT/BOLT	SIZE
1/2"-13UNC ALLEN	5/16"
9/16"-12UNC	7/8"

TOLERANCES U.N.O. .XX= ±.03 .XXX= ±.015 FRACTIONS= ANGLES=±1° MACH. FIN= ALL DIMENSIONS ARE IN INCHES.	NOTES: REMOVE BURRS AND SHARP EDGES DO NOT SCALE DWG.	APP'D	DATE
	SCALE: N/A	CK'D	DATE
		DRN	BCM
<b>TITLE SPECIFICATION</b> <b>TOP BOLT® WIDE RANGE COUPLING</b> <b>MODEL 421</b>			
<b>SMITH-BLAIR</b> TEXARKANA, ARKANSAS		P/N	N/A
DWG. NO. <b>SPEC_421.DRW</b>		4 OF 7 SHEET	9/24/24 REV.

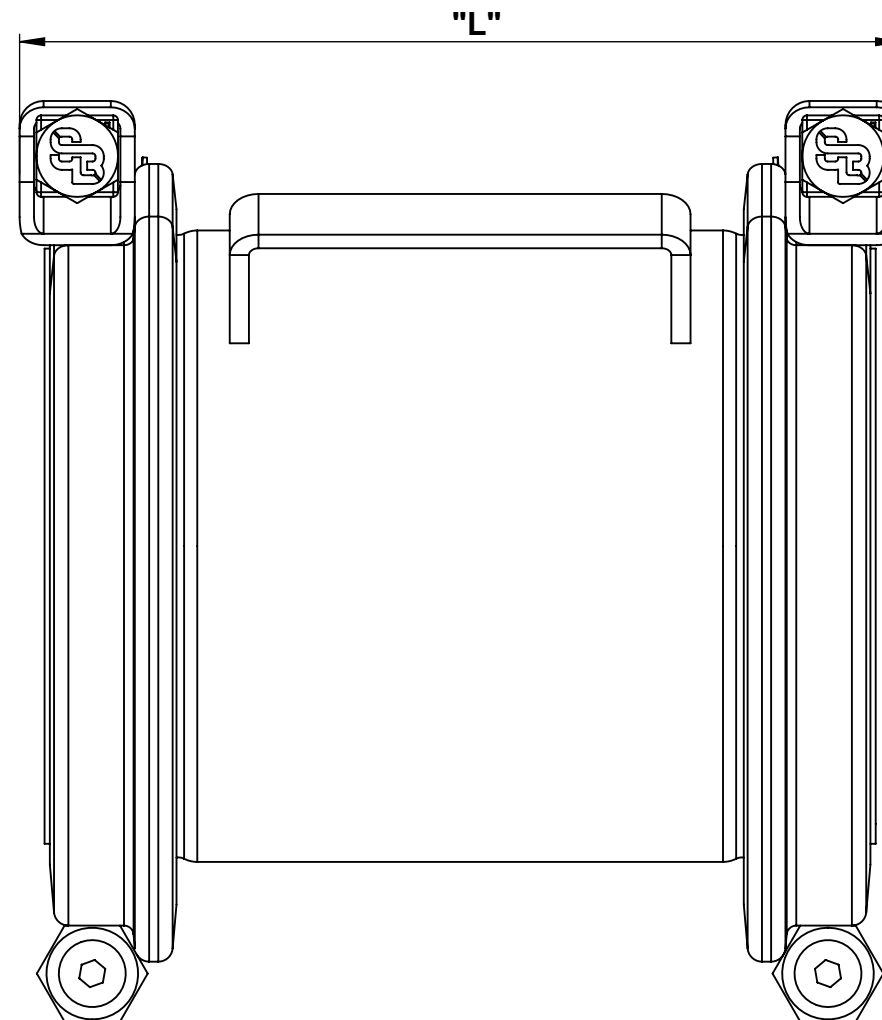
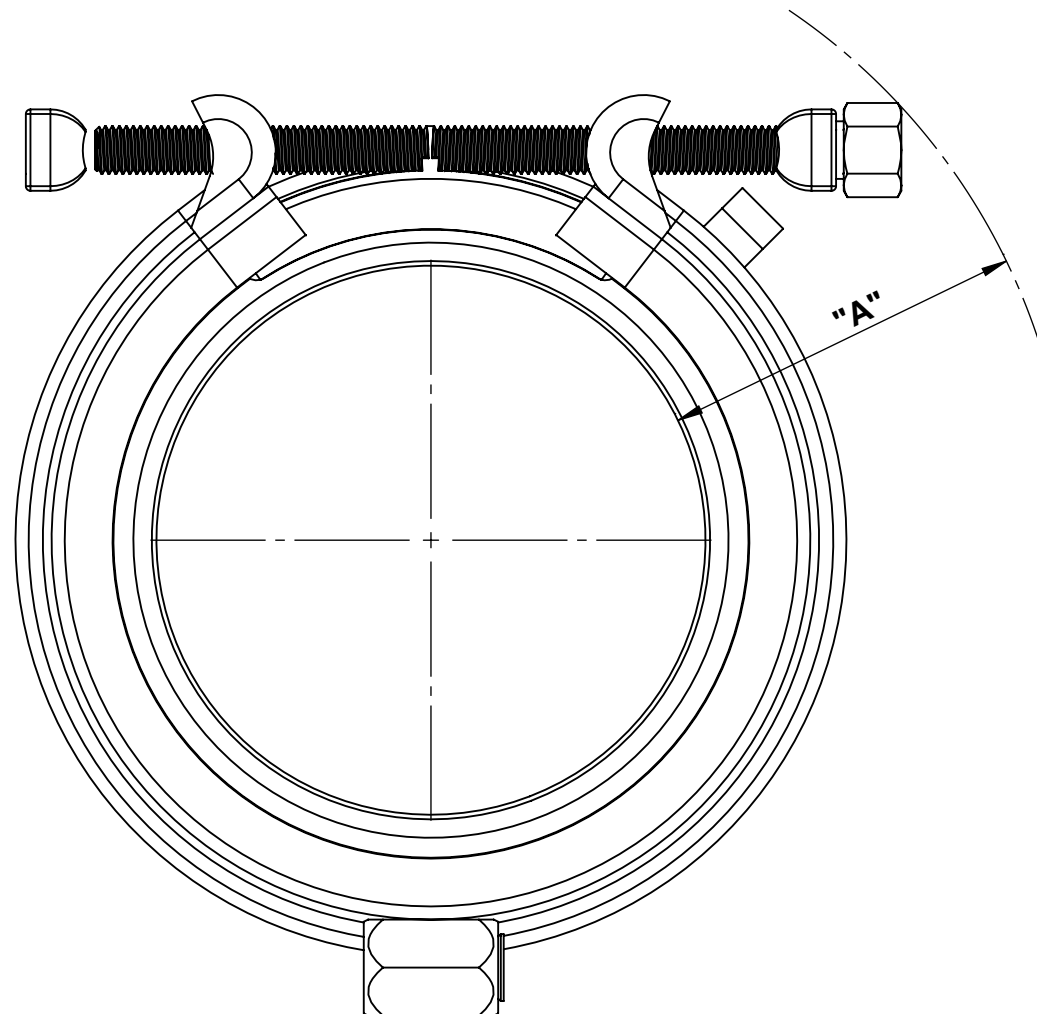

**6"-12"**  
**STANDARD COUPLING**

**NOTES:**

1. SEE CATALOG FOR PART NUMBERS AND RANGES
2. 6" COUPLING SHOWN OTHER SIZES SIMILAR

NOMINAL SIZE (IN)	A	L	BOXED WEIGHT (LBS)
6	5.00 MAX	11.75	27
8	5.00 MAX	11.75	33
10	5.00 MAX	11.75	38
12	5.00 MAX	11.75	46

WRENCH SIZE CHART	
NUT/BOLT	SIZE
1/2"-13UNC ALLEN	5/16"
5/8"-11UNC H. HEX	1-1/16"

TOLERANCES U.N.O. .XX= ±.03 .XXX= ±.015 FRACTIONS= ANGLES=±1° MACH. FIN= ALL DIMENSIONS ARE IN INCHES.	NOTES: REMOVE BURRS AND SHARP EDGES DO NOT SCALE DWG.	APP'D	DATE
	SCALE: N/A	CK'D	DATE
		DRN	BCM
TITLE <b>SPECIFICATION</b> <b>TOP BOLT® WIDE RANGE COUPLING</b> <b>MODEL 421</b>			
SMITH-BLAIR TEXARKANA, ARKANSAS		P/N N/A	
DWG. NO. <b>SPEC_421.DRW</b>		5 OF 7 SHEET	9/24/24 REV.

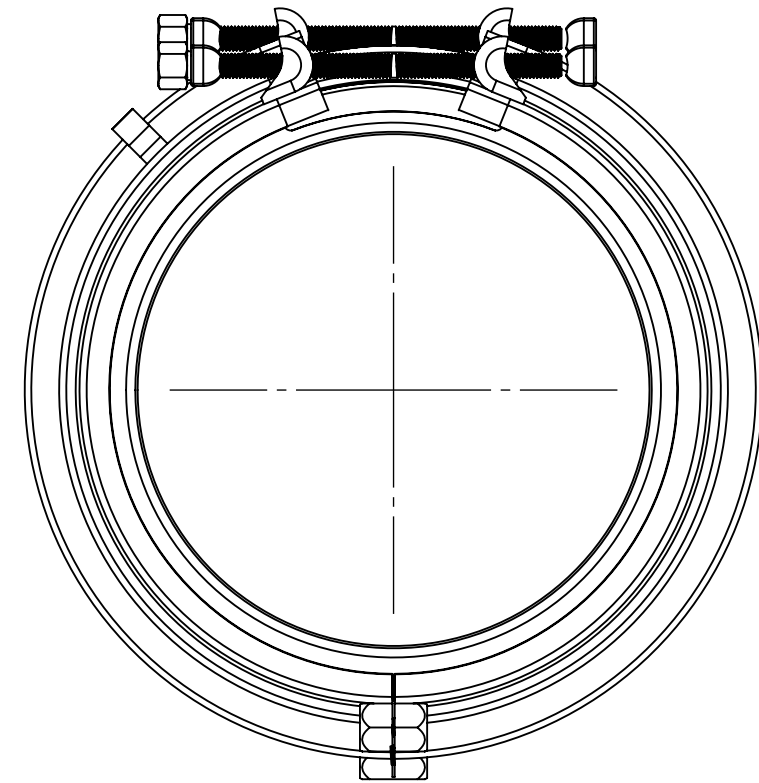
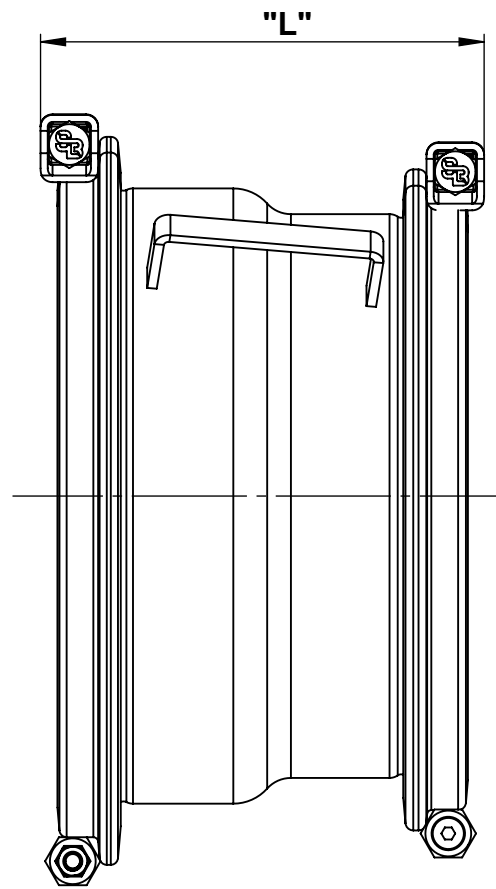
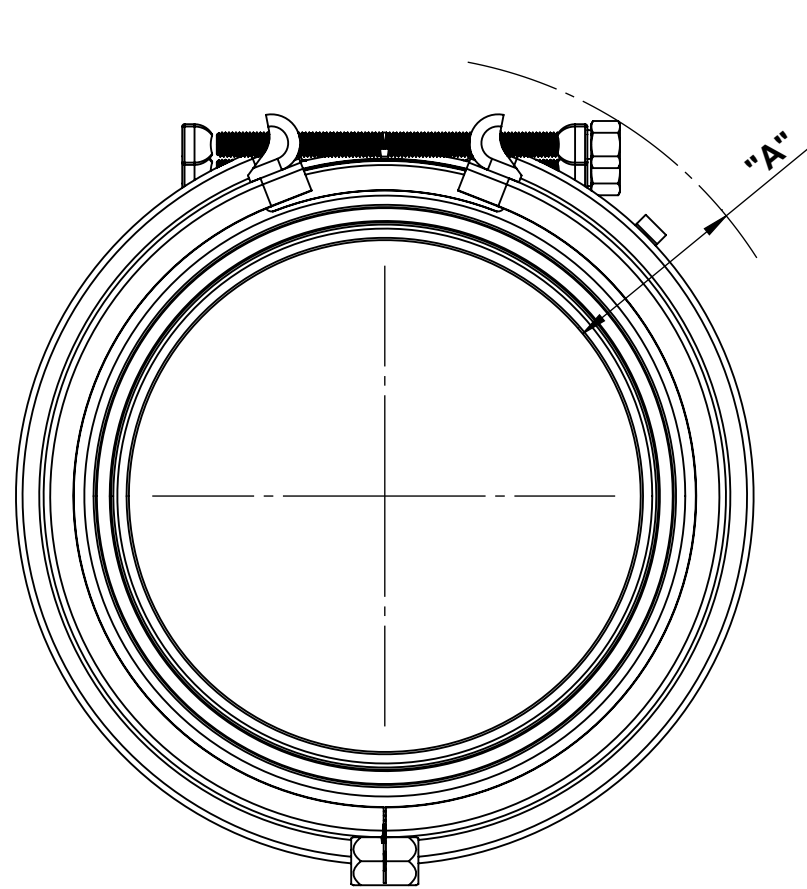

**10"-12"**  
**OVERSIZE COUPLING**

**NOTES:**

1. SEE CATALOG FOR PART NUMBERS AND RANGES.
2. 10" OVERSIZE COUPLING SHOWN OTHER SIZES SIMILAR

NOMINAL SIZE (IN)	A	L	BOXED WEIGHT (LBS)
10" OS	5.00 MAX	11.75	41
12" OS	5.00 MAX	11.75	48

WRENCH SIZE CHART	
NUT/BOLT	SIZE
1/2"-13UNC ALLEN	5/16"
5/8"-11UNC H. HEX	1-1/16"

TOLERANCES U.N.O. .XX= ±.03 .XXX= ±.015 FRACTIONS= ANGLES=±1° MACH. FIN= ALL DIMENSIONS ARE IN INCHES.	NOTES: REMOVE BURRS AND SHARP EDGES DO NOT SCALE DWG.	APP'D	DATE
	SCALE: N/A	CK'D	DATE
		DRN	BCM
TITLE <b>SPECIFICATION</b> <b>TOP BOLT® WIDE RANGE COUPLING</b> <b>MODEL 421</b>			
<b>SMITH-BLAIR</b> TEXARKANA, ARKANSAS		P/N	N/A
DWG. NO. <b>SPEC_421.DRW</b>		6 OF 7 SHEET	9/24/24 REV.

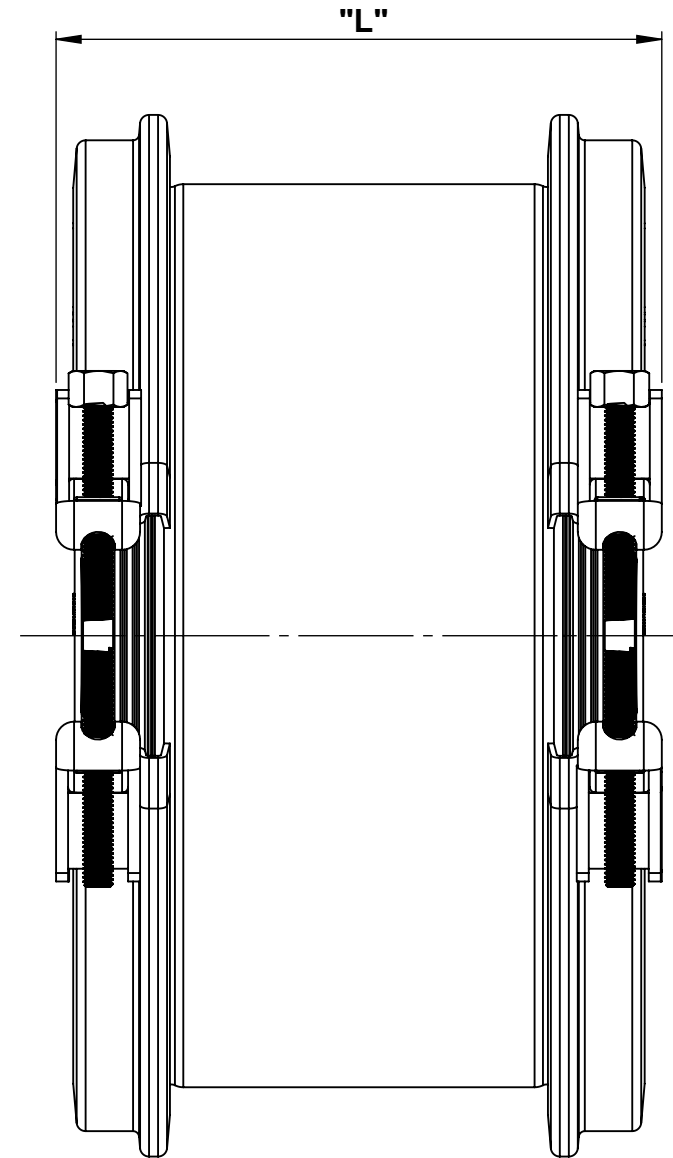
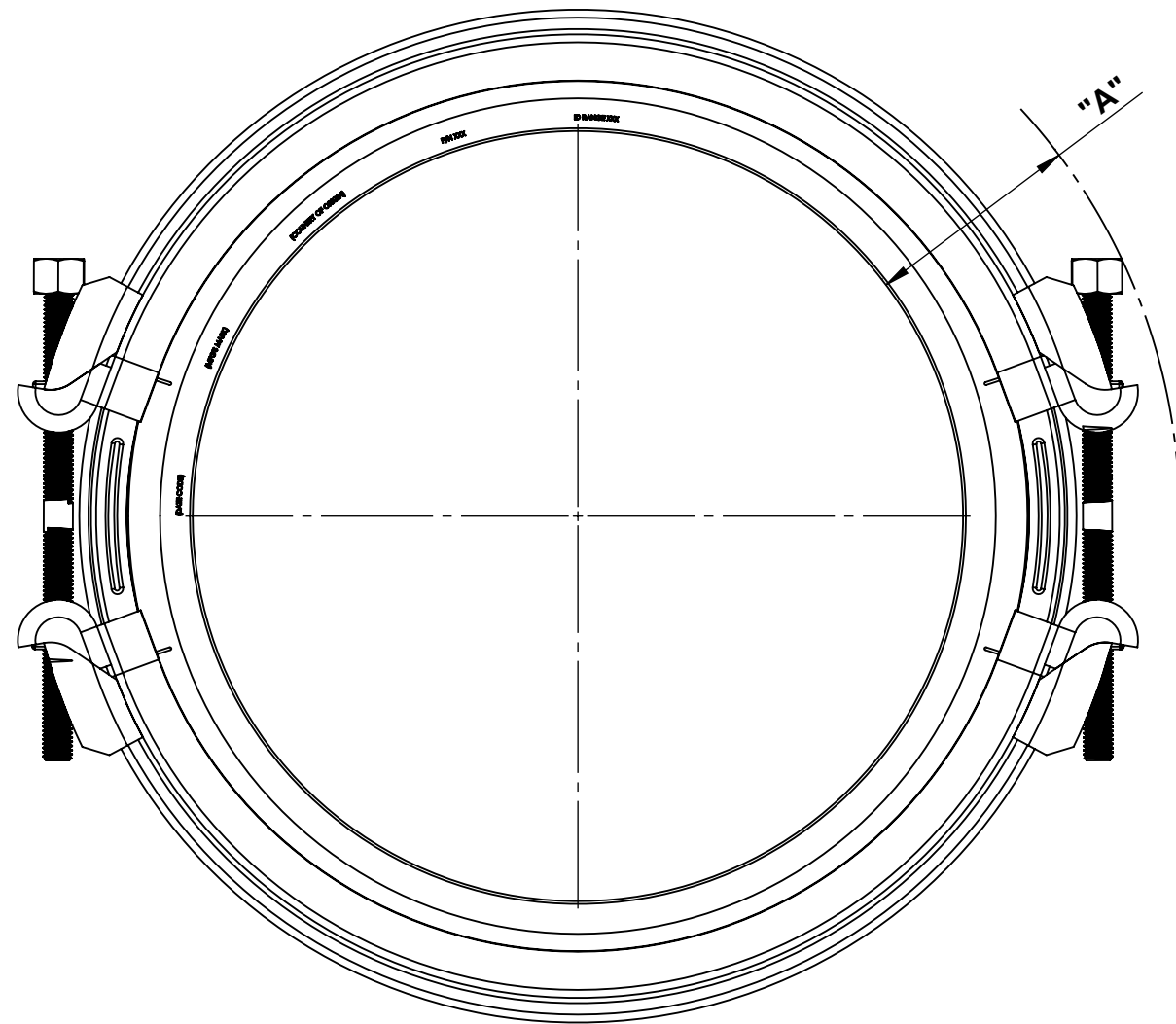

**16", 24"**

**STANDARD & OS COUPLING**

**NOTES:**

1. "A" DIMENSION IS THE SAME FOR BOTH SIDES.
2. SEE CATALOG FOR PART NUMBERS AND RANGES.
3. 16" COUPLING SHOWN
4. 16" & 24" OS SLEEVE SIMILAR TO OS SLEEVE SHOWN ON SHEET 6

NOMINAL SIZE (IN)	A	L	BOXED WEIGHT (LBS)
16"	5.00 MAX	12.63	80
16" OS	5.00 MAX	12.63	88
24"	5.00 MAX	12.63	120
24" OS	5.00 MAX	12.63	126

**WRENCH SIZE CHART**

NUT	SIZE
5/8"-11UNC H. HEX	1-1/16"

TOLERANCES U.N.O. .XX= ±.03 .XXX= ±.015 FRACTIONS= ±1° MACH. FIN=	NOTES: REMOVE BURRS AND SHARP EDGES DO NOT SCALE DWG.	APP'D	DATE
	SCALE: N/A	CK'D	DATE
ALL DIMENSIONS ARE IN INCHES.	DRN	BCM	DATE 6/4/15
TITLE <b>SPECIFICATION</b>			
TOP BOLT® WIDE RANGE COUPLING			
MODEL 421			
SMITH-BLAIR		P/N N/A	
TEXARKANA, ARKANSAS		SPEC_421.DRW	
DWG. NO.		7 OF 7 SHEET	9/24/24 REV.