

**PHB5**  
**15+ SEER2 2-Stage Packaged Heat Pump System**  
**with R-454B Refrigerant**  
**Single and Three Phase**  
**2-5 Nominal Tons (Sizes 24-60)**

**Installation Instructions**

**IMPORTANT:** Effective January 1, 2015, all split system and packaged air conditioners must be installed pursuant to applicable regional efficiency standards issued by the Department of Energy.

**NOTE:** Read the entire instruction manual before starting the installation.

**NOTE:** Installer: Make sure the Owner’s Manual and Service Instructions are left with the unit after installation.

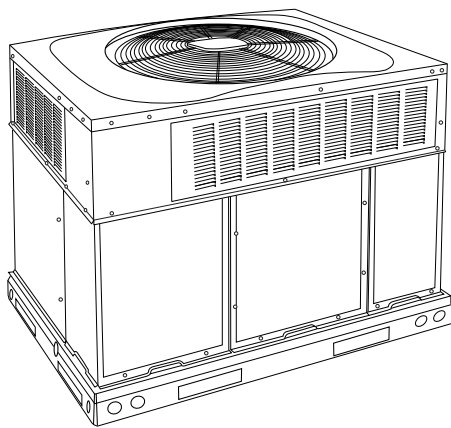

**Fig. 1 – Unit PHB5**

A09033

**Table of Contents**

Table of Contents . . . . . 1  
 Safety Considerations . . . . . 1  
 Introduction . . . . . 2  
 Receiving and Installation . . . . . 2  
     Identify Unit . . . . . 2  
     Inspect Shipment . . . . . 2  
     Roof Curb . . . . . 3  
     Slab Mount . . . . . 3  
     Inspection . . . . . 8  
     Rigging/Lifting of Unit (See Fig. 5) . . . . . 8  
     Configuring Units for Downflow (Vertical) Discharge . . . . . 9  
     High-Voltage Connections . . . . . 10  
     Special Procedures for 208-V Operation . . . . . 10  
     Control Voltage Connections . . . . . 10  
     Standard Connection . . . . . 10  
     Leak Dissipation System . . . . . 11  
     Leak Dissipation Control Board (DSB) . . . . . 11  
     Transformer Protection . . . . . 12  
 Pre-Start-up . . . . . 14  
 Start-up . . . . . 14  
     Checking and Adjusting Refrigerant Charge . . . . . 15  
     Indoor Airflow and Airflow Adjustments . . . . . 16  
     Sequence of Operation . . . . . 16  
     Demand Defrost Mode . . . . . 16  
 Maintenance . . . . . 26  
     Air Filter . . . . . 26  
     Indoor Blower and Motor . . . . . 26

Outdoor Coil, Indoor Coil, and Condensate Drain Pan . . . . . 27  
 Outdoor Fan . . . . . 27  
 Electrical Controls and Wiring . . . . . 27  
 Refrigerant Circuit . . . . . 28  
 Evaporator Airflow . . . . . 28  
 Metering Device . . . . . 28  
 Pressure Switches . . . . . 28  
 Loss of Charge Switch . . . . . 28  
 High-Pressure Switch . . . . . 28  
 Copeland Scroll Compressor R-454B Refrigerant) . . . . . 28  
 Refrigerant . . . . . 28  
 Compressor Oil . . . . . 28  
 Servicing Systems on Roofs with Synthetic Materials . . . . . 29  
 Synthetic Roof Precautionary Procedure . . . . . 29  
 Liquid Line Filter Drier . . . . . 29  
 R-454B Refrigerant Charging . . . . . 29  
 Loss of Charge Switch . . . . . 29  
 Check Defrost Thermostat . . . . . 29  
 Troubleshooting . . . . . 29  
 Start-up Checklist . . . . . 29  
 Start-Up Checklist . . . . . 31  
 Decommissioning . . . . . 32

**Safety Considerations**

This unit is equipped with electrically powered safety measures. For the safety measures to be effective, the unit must be electrically powered at all times after installation, other than when servicing.

**! WARNING**

**PERSONAL INJURY AND PROPERTY DAMAGE HAZARD**

Continuous fan mode required for proper functioning. Installation must meet the Required Minimum Dissipation Airflow as outlined in the Leak Dissipation System section. Follow instructions in the Continuous Fan Speed Set-Up section to change speeds.

Improper installation adjustment, alteration, service, maintenance, or use can cause explosion, fire, electrical shock, or other conditions which may cause death, personal injury, or property damage. Consult a qualified installer, service agency, or your distributor or branch for information or assistance. The qualified installer or agency must use factory-authorized kits or accessories when modifying this product Refer to the individual instructions packaged with the kits or accessories when installing.

Auxiliary devices which may be a POTENTIAL IGNITION SOURCE shall not be installed in the duct work. Examples of such POTENTIAL IGNITION SOURCES are hot surfaces with a temperature exceeding 1292°F (700°C) and electric switching devices.

Electrostatic air purifiers installed in the ductwork are permitted, if the purifier has an airflow sensor.

False ceilings or drop ceilings must not be used as a return air duct/plenum.

This self-contained unit is already charged with refrigerant for optimum performance, and shouldn't require any adjustments. Should any installation/service work on the A2L refrigerant system be needed, non-sparking tools are required. If the refrigerant system is opened, a refrigerant detector should be used to check for leaks. Open flames or other ignition sources should not be present, except during brazing. Brazing should only take place on refrigerant tubes that are open to the atmosphere or have been properly evacuated.

Follow all safety codes. Wear safety glasses, protective clothing, and work gloves. Use quenching cloth for brazing operations. Have a fire extinguisher available. Read these instructions thoroughly and follow all warnings or cautions included in literature and attached to the unit. Consult local building codes, the current editions of the National Electrical Code (NEC) NFPA 70.

In Canada refer to the current editions of the Canadian electrical Code CSA C22.1.

Recognize safety information. This is the safety-alert symbol . When you see this symbol on the unit and in instructions or manuals, be alert to the potential for personal injury. Understand these signal words; DANGER, WARNING, and CAUTION. These words are used with the safety-alert symbol. DANGER identifies the most serious hazards which will result in severe personal injury or death. WARNING signifies hazards which could result in personal injury or death. CAUTION is used to identify unsafe practices which may result in minor personal injury or product and property damage. NOTE is used to highlight suggestions which will result in enhanced installation, reliability, or operation.

## WARNING

### **ELECTRICAL SHOCK HAZARD**

Failure to follow this warning could result in personal injury or death. Before installing or servicing system, always turn off main power to system and install lockout tag. There may be more than one disconnect switch. Turn off accessory heater power switch if applicable.

## WARNING

### **PERSONAL INJURY AND ENVIRONMENTAL HAZARD**

Failure to relieve system pressure could result in personal injury and/or death.

1. Relieve pressure and recover all refrigerant before servicing existing equipment, and before final unit disposal. Use all service ports and open all flow-control devices, including solenoid valves.
2. Federal regulations require that you do not vent refrigerant into the atmosphere. Recover during system repair or final unit disposal.

## CAUTION

### **CUT HAZARD**

Failure to follow this caution may result in personal injury.

When removing access panels (see Fig. 23) or performing maintenance functions inside your unit, be aware of sharp sheet metal parts and screws. Although special care is taken to reduce sharp edges to a minimum, be extremely careful and wear appropriate protective clothing, safety glasses and gloves when handling parts or reaching into the unit.

## WARNING

### **PERSONAL INJURY AND PROPERTY DAMAGE HAZARD**

For continued performance, reliability, and safety, the only approved accessories and replacement parts are those specified by the equipment manufacturer. The use of non-manufacturer approved parts and accessories could invalidate the equipment limited warranty and result in fire risk, equipment malfunction, and failure. Please review manufacturer's instructions and replacement part catalogs available from your equipment supplier.

## **Introduction**

This packaged heat pump is fully self-contained and designed for outdoor installation (See Fig. 1). See Fig. 2 and Fig. 3 for unit dimensions. All unit sizes have discharge openings for both horizontal and downflow configurations, and are factory shipped with all downflow duct openings covered. The unit may be installed either on a rooftop or on a ground-level cement slab. (See Fig. 4 for roof curb dimensions.)

## NOTICE

If the unit gasketing or insulation must be replaced, ensure the material used is compliant with the two agency requirements listed.

1. Insulation and adhesives shall meet NFPA 90.1 requirements for flame spread and smoke generation.
2. Cabinet insulation shall meet ASHRAE Standard 62.2.

## **Receiving and Installation**

**Transport and Storage Considerations** This unit employs R-454B refrigerant, which is flammable. Regulations may exist with respect to the transportation of this unit, including number of units and the configuration of the equipment in the load transported. Storage of unit should be in accordance with applicable regulations or instructions, whichever is more stringent. This includes the number of units that may be stored together. For disposal of unit, refer to national regulations, and follow the Decommissioning section in this manual.

### **Step 1 – Check Equipment**

#### **Identify Unit**

The unit model number and serial number are printed on the unit informative plate. Check this information against shipping papers.

#### **Inspect Shipment**

Inspect for shipping damage before removing packaging materials. If unit appears to be damaged or is torn loose from its anchorage, have it examined by transportation inspectors before removal. Forward claim papers directly to transportation company. Manufacturer is not responsible for any damage incurred in transit. Check all items against shipping list. Immediately notify the nearest equipment distribution office if any item is missing. To prevent loss or damage, leave all parts in original packages until installation.

If the unit is to be mounted on a curb in a downflow application, review Step 7 to determine which method is to be used to remove the downflow panels before rigging and lifting into place. The panel removal process may require the unit to be on the ground.

## Step 2 – Provide Unit Support

**IMPORTANT:** The unit must be secured to the curb by installing screws through the bottom of the curb flange and into the unit base rails. When installing large base units onto the common curb, the screws must be installed before allowing the full weight of the unit to rest on the curb. A minimum of six screws are required for large base units. Failure to secure unit properly could result in an unstable unit. See Warning near Rigging/Lifting information and accessory curb instructions for more details.

For hurricane tie downs, contact distributor for details and PE (Professional Engineering) Certificate if required.

### Roof Curb

Install accessory roof curb in accordance with instructions shipped with curb (See Fig. 4). Install insulation, cant strips, roofing, and flashing. Ductwork must be attached to curb.

**IMPORTANT:** The gasketing of the unit to the roof curb is critical for a water tight seal. Install gasketing material supplied with the roof curb. Improperly applied gasketing also can result in air leaks and poor unit performance.

Curb should be level to within 1/4 in. (6.35 mm) (See Fig. 6). This is necessary for unit drain to function properly. Refer to accessory roof curb installation instructions for additional information as required.

Installation on older “G” series roof curbs.

Two accessory kits are available to aid in installing a new “G” series unit on an old “G” roof curb.

1. Accessory kit number CPADCURB001A00, (small chassis) and accessory kit number CPADCURB002A00, (large chassis) includes roof curb adapter and gaskets for the perimeter seal and duct openings. No additional modifications to the curb are required when using this kit.
2. An alternative to the adapter curb is to modify the existing curb by removing the outer horizontal flange and use accessory kit number CPGSKTKIT001A00 which includes spacer blocks (for easy alignment to existing curb) and gaskets for the perimeter seal and duct openings. This kit is used when existing curb is modified by removing outer horizontal flange.

## CAUTION

### UNIT/STRUCTURAL DAMAGE HAZARD

Failure to follow this caution may result in property damage.

Ensure there is sufficient clearance for saw blade when cutting the outer horizontal flange of the roof curb so there is no damage to the roof or flashing.

### Slab Mount

Place the unit on a solid, level pad that is at least 2 in. (51 mm) above grade. The pad should extend approximately 2 in. (51 mm) beyond the casing on all 4 sides of the unit (See Fig. 7). Do not secure the unit to the pad except when required by local codes.

COOLING CAPACITY		UNIT WT.		UNIT HEIGHT IN/MM		CENTER OF GRAVITY IN/MM					
LB		KG		"A"		X		Y		Z	
24	382	173.3	51-3/4	1315	20-1/2	520.7	15-3/4	400.1	23.0	584.2	

UNIT	CORNER WEIGHT LB/KG			
	"1"	"2"	"3"	"4"
24	57.3	126.0	176.4	34.7

NOTE: 1. ALL TABLE DATA RELEVANT FOR ALL FACTORY INSTALLED OPTIONS EXCEPT ECONOMIZER.  
 2. \* - INDICATES ALL FLOP CODES FOR THE MODELS LISTED.

**REQUIRED CLEARANCES TO COMBUSTIBLE MTL.**

	INCHES (MM)
TOP OF UNIT.....	1 (25.4)
DUCT SIDE OF UNIT.....	2 (50.8)
SIDE OPPOSITE DUCTS.....	14 (355.6)
BOTTOM OF UNIT.....	0 (0.0)
ELECTRICAL PANEL.....	36 (914.4)

**NEC REQUIRED CLEARANCES**

	INCHES (MM)
BETWEEN UNITS, POWER ENTRY SIDE.....	42 (1066.8)
BETWEEN UNITS, COMPRESSOR ENTRY SIDE.....	36 (914.4)
UNIT AND BLOCK OR CONCRETE WALLS AND OTHER GROUNDED SURFACES, POWER ENTRY SIDE.....	42 (1066.8)

**REQUIRED CLEARANCE FOR OPERATION AND SERVICING**

	INCHES (MM)
EVAP. COIL ACCESS SIDE.....	36 (914.4)
POWER ENTRY SIDE.....	42 (1066.8)
(EXCEPT FOR NEC REQUIREMENTS)	
DUCT SIDE OPPOSITE DUCTS.....	48 (1219.2)
DUCT PANEL.....	36 (914.4)
	12 (304.8)

\*MINIMUM DISTANCES IF UNIT IS PLACED LESS THAN 12 (304.8) FROM WALL SYSTEM, THEN SYSTEM PERFORMANCE MAY BE COMPROMISED.

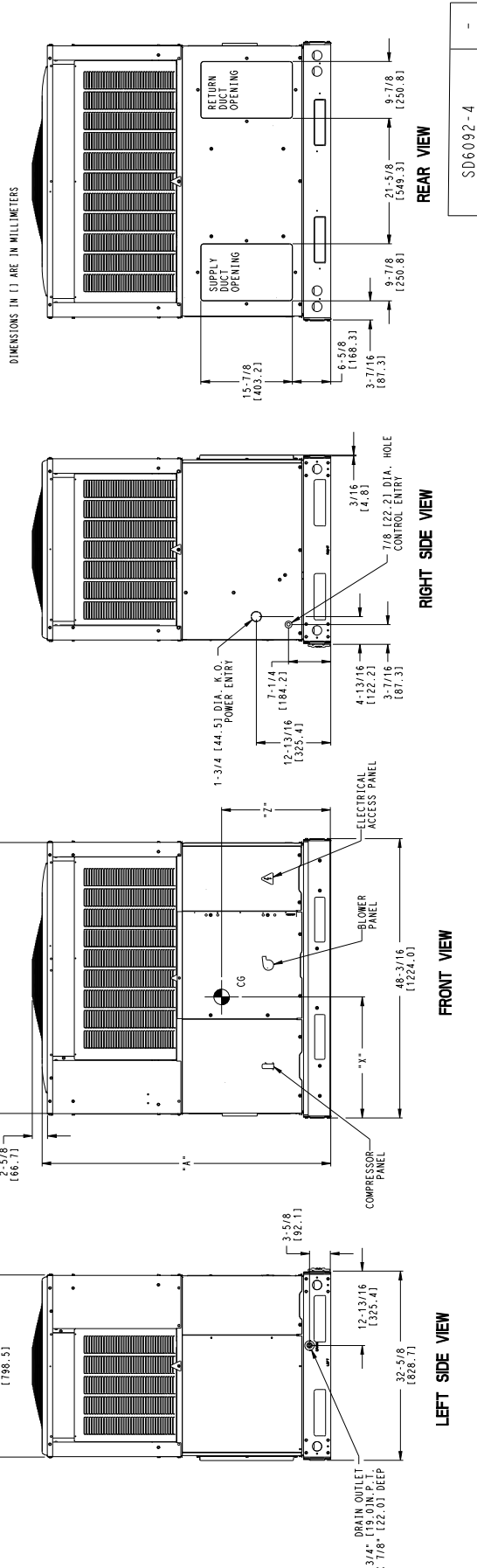

SD6092-4

Fig. 2 – PHB5 24 Unit Dimensions

COOLING CAPACITY	UNIT WT.		UNIT HEIGHT		CENTER OF GRAVITY		
	LB	KG	"A"	"A"	X	Y	Z
36	428	194.2	50-3/4	1289	20-1/4	514.4	17-5/8
48	479	217.3	54-3/4	1391	20-1/4	514.4	17-1/2
60	533	241.8	54-3/4	1391	20-1/4	514.4	17-1/2

UNIT	CORNER WEIGHTS LB/KG			
	"1"	"2"	"3"	"4"
36	64.2	29.1	85.6	38.8
48	71.9	32.6	95.8	43.5
60	80.0	36.3	106.6	48.4

NOTE: 1. ALL TABLE DATA RELEVANT FOR ALL FACTORY INSTALLED OPTIONS EXCEPT ECONOMIZER.  
 2. \* - INDICATES ALL FIP CODES FOR THE MODELS LISTED.

**REQUIRED CLEARANCES TO COMBUSTIBLE MATL.**

	INCHES [MM]
TOP OF UNIT	4 [101.6]
DUCT SIDE OF UNIT	2 [50.8]
SIDE OPPOSITE DUCTS	14 [355.6]
BOTTOM OF UNIT	0 [0.0]
ELECTRICAL PANEL	36 [914.4]

**NEC REQUIRED CLEARANCES.**

	INCHES [MM]
BETWEEN UNITS, POWER ENTRY SIDE	42 [1066.8]
UNIT AND UNGROUNDED SURFACES, POWER ENTRY SIDE	36 [914.0]
UNIT AND UNGROUNDED SURFACES, OTHER GROUNDED SURFACES, POWER ENTRY SIDE	42 [1066.8]

**REQUIRED CLEARANCE FOR OPERATION AND SERVICING**

	INCHES [MM]
EVAP. COIL, ACCESS SIDE	154 [3901.6]
POWER ENTRY SIDE (EXCEPT FOR NEC REQUIREMENTS)	22 [558.8]
UNIT TOP (EXCEPT FOR NEC REQUIREMENTS)	48 [1219.2]
SIDE OPPOSITE DUCTS	36 [914.0]
DUCT PANEL	12 [304.8]

\*MINIMUM DISTANCES: IF UNIT IS PLACED LESS THAN 12 (304.8) FROM WALL SYSTEM, THEN SYSTEM PERFORMANCE MAYBE COMPROMISED. DIMENSIONS IN ( ) ARE IN MM

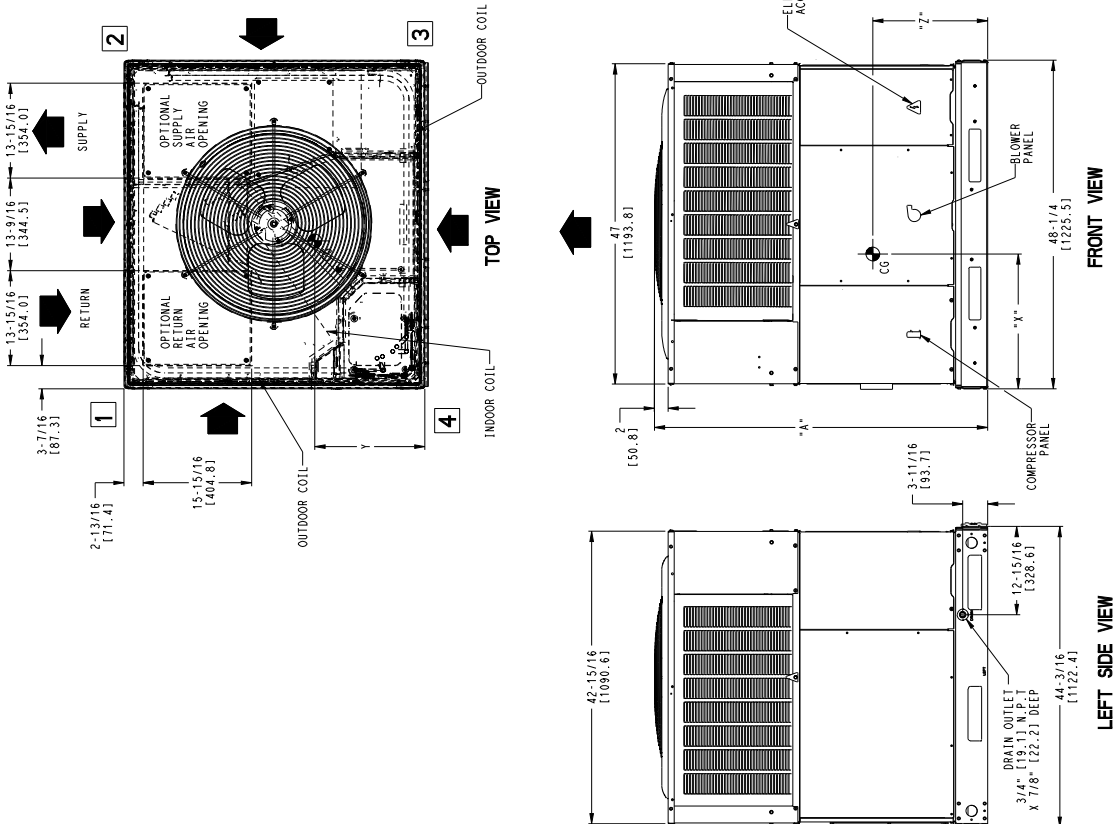

SD6092-4

Fig. 3 – PHB5 36-60 Unit Dimensions

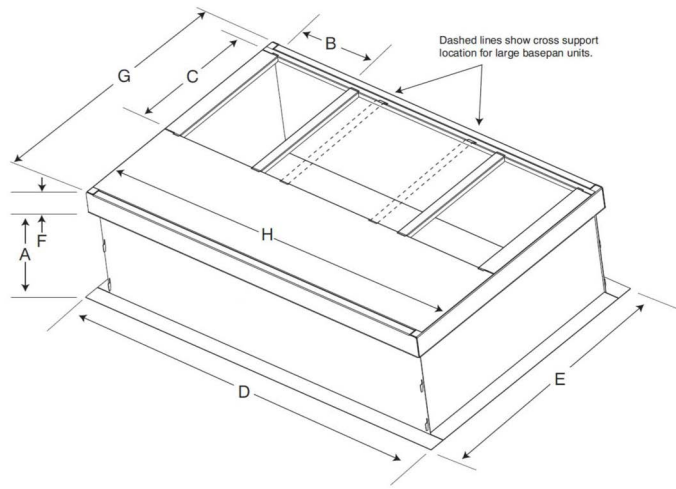
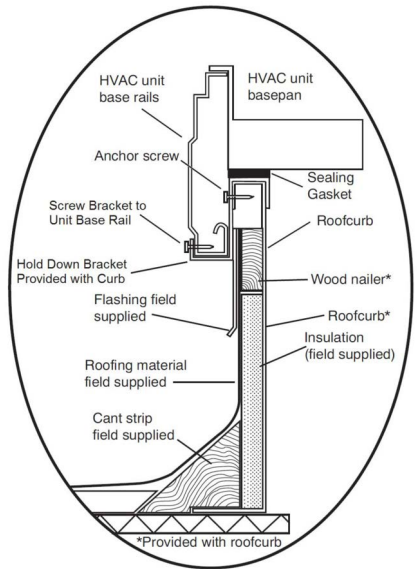

SMALL/COMMON CURB

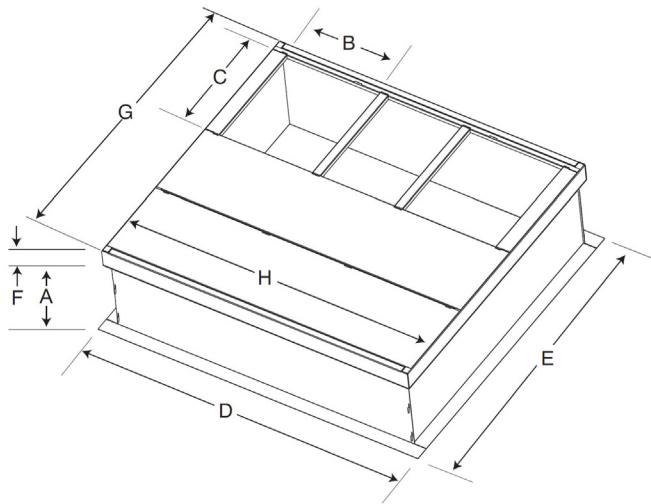

LARGE CURB

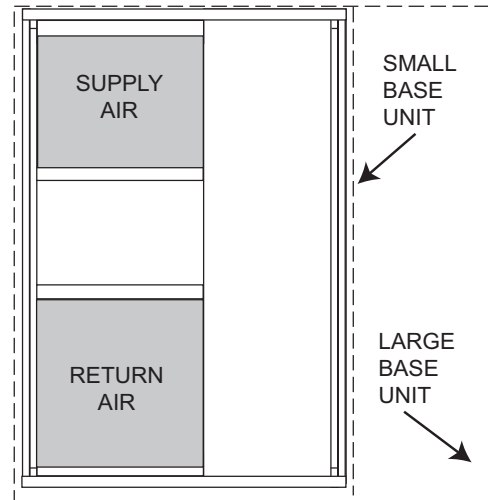

UNIT PLACEMENT ON COMMON CURB

SMALL OR LARGE BASE UNIT

A180216

UNIT SIZE	CATALOG NUMBER	A IN. (mm)	B (small/common base) IN. (mm)*	B (large base) IN. (mm)*	C IN. (mm)	D IN. (mm)	E IN. (mm)	F IN. (mm)	G IN. (mm)	H IN. (mm)
Small or Large	CPRFCURB011B00	14 (356)	10 (254)	14 (356)	16 (406)	47.8 (1214)	32.4 (822)	2.7 (69)	30.6 (778)	46.1 (1170)
Large	CPRFCURB013B00	14 (356)	14 (356)				43.9 (1116)			

\*. Part Number CPRCURB011B00 can be used on both small and large basepan units. The cross supports must be located based on whether the unit is a small basepan or a large basepan.

NOTES:

1. Roof curb must be set up for unit being installed.
2. Seal strip must be applied, as required, to unit being installed.
3. Roof curb is made of 16-gauge steel.
4. Attach ductwork to curb (flanges of duct rest on curb).
5. Insulated panels: 1-in. (25.4 mm) thick fiberglass 1 lb. density.

Fig. 4 – Roof Curb Dimensions

**⚠ CAUTION - NOTICE TO RIGGERS**  
**⚠ PRUDENCE - AVIS AUX MANIPULATEUR**  
 ACCESS PANELS MUST BE IN PLACE WHEN RIGGING.  
 PANNEAUX D'ACCES DOIT ÊTRE EN PLACE POUR MANIPULATION.

Use top skid as spreader bar. / Utiliser la palette du haut comme barre de répartition

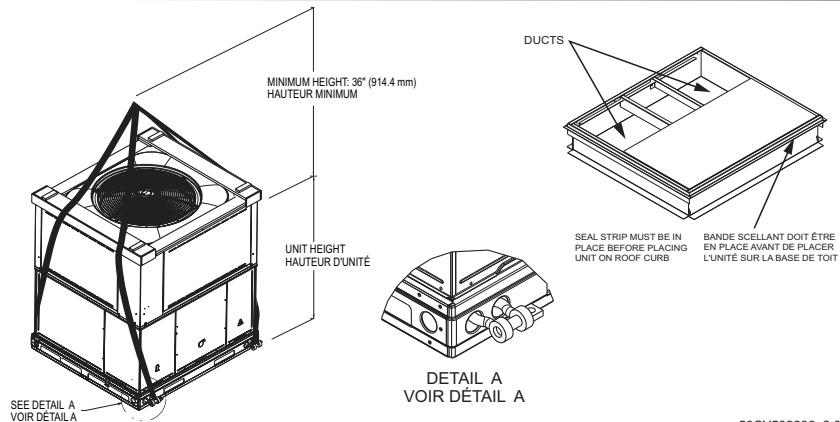

50CY502286 2.0

A09051

**Standard Copper Tube Aluminum Fin**

SMALL CABINET			LARGE CABINET						
Unit*	24		Unit*	36		48		60	
	lb	kg		lb	kg	lb	kg	lb	kg
Rigging Weight	393	178	Rigging Weight	442	201	493	224	547	248

\*. See dimensional drawing for corner weighs.

Fig. 5 – Unit Suggested Rigging

**Step 3 – Provide Clearances**

The required minimum service clearances are shown in Fig. 2 and Fig. 3. Adequate ventilation and outdoor air must be provided. The outdoor fan draws air through the outdoor coil and discharges it through the top fan grille. Be sure that the fan discharge does not recirculate to the outdoor coil. Do not locate the unit in either a corner or under an overhead obstruction. The minimum clearance under a partial overhang (such as a normal house overhang) is 48 in. (1219 mm) above the unit top. The maximum horizontal extension of a partial overhang must not exceed 48 in. (1219 mm)

**IMPORTANT:** Do not restrict outdoor airflow. An air restriction at either the outdoor-air inlet or the fan discharge may be detrimental to compressor life.

Do not place the unit where water, ice, or snow from an overhang or roof will damage or flood the unit. Do not install the unit on carpeting or other combustible materials. Slab-mounted units should be at least 2 in. (51 mm) above the highest expected water and runoff levels. Do not use unit if it has been under water.

**Step 4 – Field-Fabricate Ductwork**

Secure all ducts to roof curb and building structure on vertical discharge units. Do not connect ductwork to unit. For horizontal applications, unit is provided with flanges on the horizontal openings. All ductwork should be secured to the flanges. Insulate and weatherproof all external ductwork, joints, and roof openings with counter flashing and mastic in accordance with applicable codes.

Ducts passing through an unconditioned space must be insulated and covered with a vapor barrier. If a plenum return is used on a vertical unit, the return should be ducted through the roof deck to comply with applicable fire codes. See unit rating plate for any required clearances around ductwork. Cabinet return-air static shall not exceed -.25 IN. W.C.

**Step 5 – Rig and Place Unit**

**⚠ WARNING**

**PERSONAL INJURY OR PROPERTY DAMAGE HAZARD**

Failure to follow this warning could result in personal injury, death or property damage.

When installing the unit on a rooftop, be sure the roof will support the additional weight.

Rigging and handling of this equipment can be hazardous for many reasons due to the installation location (roofs, elevated structures, etc.).

Only trained, qualified crane operators and ground support staff should handle and install this equipment.

When working with this equipment, observe precautions in the literature, on tags, stickers, and labels attached to the equipment, and any other safety precautions that might apply.

Training for operators of the lifting equipment should include, but not be limited to, the following:

1. Application of the lifter to the load, and adjustment of the lifts to adapt to various sizes or kinds of loads.
2. Instruction in any special operation or precaution.
3. Condition of the load as it relates to operation of the lifting kit, such as balance, temperature, etc.

Follow all applicable safety codes. Wear safety shoes and work gloves.

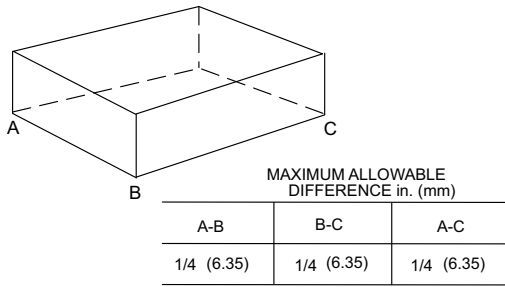

Fig. 6 – Unit Leveling Tolerances

A07925

**Inspection**

Prior to initial use, and at monthly intervals, all rigging shackles, clevis pins, and straps should be visually inspected for any damage, evidence of wear, structural deformation, or cracks. Particular attention should be paid to excessive wear at hoist hooking points and load support areas. Materials showing any kind of wear in these areas must not be used and should be discarded.

**! WARNING**

**UNIT FALLING HAZARD**  
Failure to follow this warning could result in personal injury or death. Never stand beneath rigged units or lift over people.

1. Leave top shipping skid on the unit for use as a spreader bar to prevent the rigging straps from damaging the unit. If the skid is not available, use a spreader bar of sufficient length to protect the unit from damage.

**! WARNING**

**PROPERTY DAMAGE HAZARD**  
Failure to follow this warning could result in personal injury. When straps are taut, the clevis should be a minimum of 36 in. (914 mm) above the unit top cover.

**Rigging/Lifting of Unit (See Fig. 5)**

**! WARNING**

**UNIT FALLING HAZARD**  
Failure to follow this warning could result in personal injury or death. Large base units must be secured to common curb before allowing full weight of unit to rest on curb. Install screws through curb into unit base rails while rigging crane is still supporting unit.

Lifting holes are provided in base rails as shown.

1. Attach shackles, clevis pins, and straps to the base rails of the unit. Be sure materials are rated to hold the weight of the unit (See Fig. 5).
2. Attach a clevis of sufficient strength in the middle of the straps. Adjust the clevis location to ensure unit is lifted level with the ground.

After the unit is placed on the roof curb or mounting pad, remove the top skid.

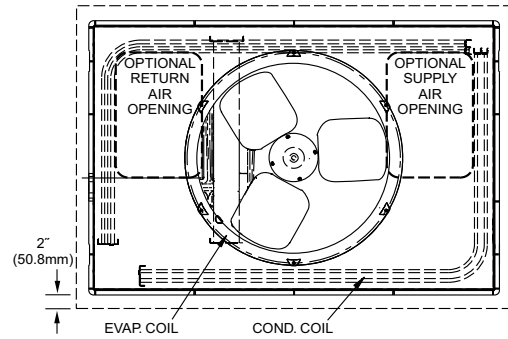

Fig. 7 – Slab Mounting Detail

A07926

**Step 6 – Connect Condensate Drain**

**NOTE:** When installing condensate drain connection be sure to comply with local codes and restrictions.

This unit disposes of condensate water through a 3/4 in. NPT fitting which exits through the base on the evaporator coil access side. See Fig. 2 and Fig. 3 for location.

Condensate water can be drained directly onto the roof in rooftop installations (where permitted) or onto a gravel apron in ground level installations. Install a field-supplied 2-in. (51 mm) condensate trap at end of condensate connection to ensure proper drainage. Make sure that the outlet of the trap is at least 1 in. (25 mm) lower than the drain pan condensate connection to prevent the pan from overflowing (See Fig. 8). When using a gravel apron, make sure it slopes away from the unit.

Connect a drain tube using a minimum of 3/4 -in. PVC or 3/4 -in. copper pipe (all field-supplied) at the outlet end of the 2-in. (51 mm) trap. Do not undersize the tube. Pitch the drain tube downward at a slope of at least 1-in. (25 mm) for every 10 ft (3.1 m) of horizontal run. Be sure to check the drain tube for leaks. Prime trap at the beginning of the cooling season start-up.

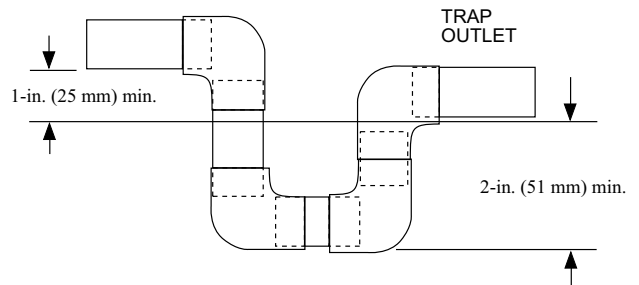

Fig. 8 – Condensate Trap

A09052

**Step 7 – Install Duct Connections**

The design and installation of the duct system must be in accordance with the standards of the NFPA for installation of non-residence type air conditioning and ventilating systems, NFPA 90A or residence type, NFPA 90B and/or local codes and ordinances.

Select and size ductwork, supply-air registers, and return air grilles according to ASHRAE (American Society of Heating, Refrigeration, and Air Conditioning Engineers) recommendations. The unit has duct flanges on the supply- and return-air openings on the side of the unit.

When designing and installing ductwork, consider the following:

1. All units should have field-supplied filters or accessory filter rack installed in the return-air side of the unit. Recommended sizes for filters are shown in Table 3.
2. Avoid abrupt duct size increases and reductions. Abrupt change in duct size adversely affects air performance.

**IMPORTANT:** Use flexible connectors between ductwork and unit to prevent transmission of vibration. Use suitable gaskets to ensure

weather-tight and airtight seal. When electric heat is installed, use fireproof canvas (or similar heat resistant material) connector between ductwork and unit discharge connection. If flexible duct is used, insert a sheet metal sleeve inside duct. Heat resistant duct connector (or sheet metal sleeve) must extend 24-in. (610 mm) from electric heater element.

3. Size ductwork for cooling air quantity (cfm). The minimum air quantity for proper electric heater operation is listed in [Table 4](#). Heater limit switches may trip at air quantities below those recommended.
4. Seal, insulate, and weatherproof all external ductwork. Seal, insulate and cover with a vapor barrier all ductwork passing through conditioned spaces. Follow latest Sheet Metal and Air Conditioning Contractors National Association (SMACNA) and Air Conditioning Contractors Association (ACCA) minimum installation standards for residential heating and air conditioning systems.
5. Secure all ducts to building structure. Flash, weatherproof, and vibration-isolate duct openings in wall or roof according to good construction practices.

**Configuring Units for Downflow (Vertical) Discharge**

**WARNING**

**ELECTRICAL SHOCK HAZARD**

Failure to follow this warning could result in personal injury or death. Before performing service or maintenance operations on the system, turn off main power to unit and install lockout tag. There may be more than one disconnect switch.

1. Open all electrical disconnects and install lockout tag before starting any service work.
2. Remove horizontal (metal) ductcovers to access vertical (downflow) discharge duct knockouts in unit basepan. (See [Fig. 9](#).)

To remove downflow return and supply knockout covers, break front and right side connecting tabs with a screwdriver and hammer. Push cover down to break rear and left side tabs.

**NOTE:** These panels are held in place with tabs similar to an electrical knockout. Reinstall horizontal duct covers ([Fig. 9](#)) shipped on unit from factory. Insure openings are air and watertight.

**NOTE:** The design and installation of the duct system must be in accordance with the standards of the NFPA for installation of nonresidence-type air conditioning and ventilating systems, NFPA 90A or residence-type, NFPA 90B; and/or local codes and ordinances.

Adhere to the following criteria when selecting, sizing, and installing the duct system:

1. Units are shipped for side shot installation.
2. Select and size ductwork, supply-air registers, and return-air grilles according to American Society of Heating, Refrigeration and Air Conditioning Engineers (ASHRAE) recommendations.
3. Use flexible transition between rigid ductwork and unit to prevent transmission of vibration. The transition may be screwed or bolted to duct flanges. Use suitable gaskets to ensure weather-tight and airtight seal.
4. All units must have field-supplied filters or accessory filter rack installed in the return-air side of the unit. Recommended sizes for filters are shown in [Table 3](#).
5. Size all ductwork for maximum required airflow (either heating or cooling) for unit being installed. Avoid abrupt duct size increases or decreases or performance may be affected.
6. Adequately insulate and weatherproof all ductwork located outdoors. Insulate ducts passing through unconditioned space, and use vapor barrier in accordance with latest issue of Sheet Metal and

Air Conditioning Contractors National Association (SMACNA) and Air Conditioning Contractors of America (ACCA) minimum installation standards for heating and air conditioning systems. Secure all ducts to building structure.

7. Flash, weatherproof, and vibration-isolate all openings in building structure in accordance with local codes and good building practices.

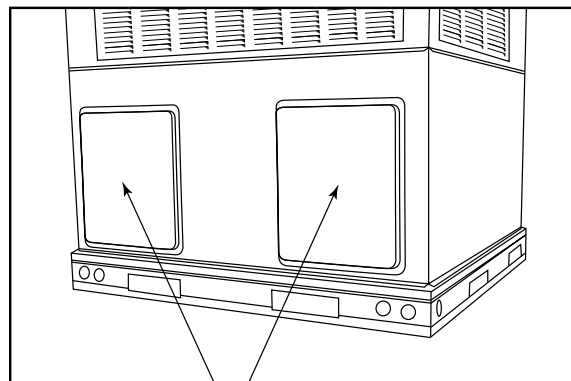

Horizontal Duct Covers

A09076

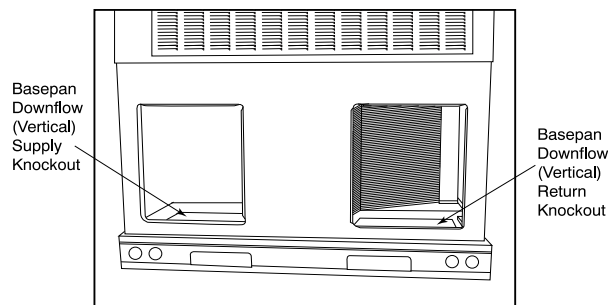

A09093

**Fig. 9 – Supply and Return Duct Opening**  
**Step 8 – Install Electrical Connections**

**WARNING**

**ELECTRICAL SHOCK HAZARD**

Failure to follow this warning could result in personal injury or death. The unit cabinet must have an uninterrupted, unbroken electrical ground to minimize the possibility of personal injury if an electrical fault should occur. This ground may consist of an electrical wire connected to the unit ground screw in the control compartment, or conduit approved for electrical ground when installed in accordance with NFPA 70 (NEC) (latest edition) (in Canada, Canadian Electrical Code CSA C22.1) and local electrical codes.

# CAUTION

## UNIT COMPONENT DAMAGE HAZARD

Failure to follow this caution may result in damage to the unit being installed.

1. Make all electrical connections in accordance with NFPA 70 (NEC) (latest edition) and local electrical codes governing such wiring. In Canada, all electrical connections must be in accordance with CSA standard C22.1 Canadian Electrical Code Part 1 and applicable local codes. Refer to unit wiring diagram.
2. Use only copper conductor for connections between field-supplied electrical disconnect switch and unit. **DO NOT USE ALUMINUM WIRE.**
3. Be sure that high-voltage power to unit is within operating voltage range indicated on unit rating plate. On 3-phase units, ensure phases are balanced within 2 percent. Consult local power company for correction of improper voltage and/or phase imbalance.
4. Do not damage internal components when drilling through any panel to mount electrical hardware, conduit, etc.
5. Route field power supply(s) away from areas that could be damaged by lawn and garden equipment or other accidental damage.

## High-Voltage Connections

The unit must have a separate electrical service with a field-supplied, waterproof disconnect switch mounted at, or within sight from the unit. Refer to the unit rating plate, NEC and local codes for maximum fuse/circuit breaker size and minimum circuit amps (ampacity) for wire sizing.

The field-supplied disconnect may be mounted on the unit over the high-voltage inlet hole when the standard power and low-voltage entry points are used. See Fig. 2 and Fig. 3 for acceptable location.

See unit wiring label (Fig. 17 - Fig. 20) and Fig. 10 for reference when making high voltage connections. Proceed as follows to complete the high-voltage connections to the unit.

Single phase units:

1. Run the high-voltage (L1, L2) and ground lead into the control box.
2. Connect ground lead to chassis ground connection.
3. Locate the black and yellow wires connected to the line side of the contactor.
4. Connect field L1 to black wire from connection 11 of the compressor contactor.
5. Connect field wire L2 to yellow wire from connection 23 of the compressor contactor.

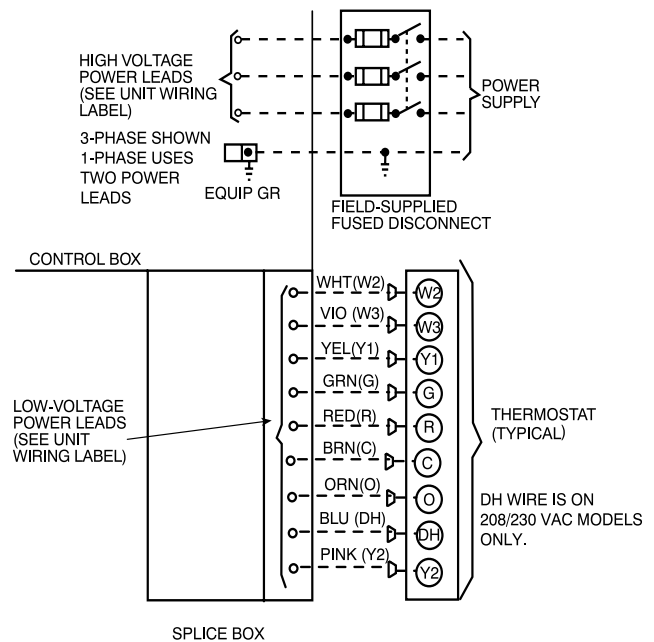

Fig. 10 – High- and Control-Voltage Connections

A13176

Three-phase units:

1. Run the high-voltage (L1, L2, L3) and ground lead into the control box.
2. Connect ground lead to chassis ground connection.
3. Locate the black and yellow wires connected to the line side of the contactor.
4. Connect field L1 to black wire from connection 11 of the compressor contactor.
5. Connect field wire L3 to yellow wire from connection 13 of the compressor contactor.
6. Connect field wire L2 to blue wire from compressor.

## Special Procedures for 208-V Operation

# WARNING

## ELECTRICAL SHOCK HAZARD

Failure to follow this warning could result in personal injury or death. Before installing or servicing system, always turn off main power to system and install lockout tag. With disconnect switch open, move black wire from transformer (3/16 in.)(4.8 mm) terminal marked 230 to terminal marked 208. This retaps transformer to primary voltage of 208 vac.

## Control Voltage Connections

**NOTE:** Do not use any type of power-stealing thermostat. Unit control problems may result.

Use no. 18 American Wire Gage (AWG) color-coded, insulated (35°C minimum) wires to make the control voltage connections between the thermostat and the unit. If the thermostat is located more than 100 ft (30.5 m) from the unit (as measured along the control voltage wires), use no. 16 AWG color-coded, insulated (35° C minimum) wires.

## Standard Connection

Locate the nine low voltage thermostat leads (eight for 460 VAC models) in 24 volt splice box. See Fig. 10 for connection diagram. Run the low-voltage leads from the thermostat, through the control wiring inlet hole grommet (Fig. 2 and Fig. 3), and into the low-voltage splice box. Provide a drip loop before running wires through panel. Secure and strain relief all wires so that they do not interfere with operation of unit.

If an accessory electric heater is installed, low voltage leads from heater must be connected to factory supplied control leads from Indoor Fan Board P4 connector.

**NOTE:** If the unit 24V wires do not have a matching receptacle, cut the 24V wires from the electric heater plug, strip the ends, and wire nut together to match the schematic connections. If the electric heater 24V wires do not have a matching plug, cut the 24V wires from the unit receptacle, strip the ends, and wire nut together to match the schematic connections.

Factory wires are provided for electric heat staging W1 and W2 (W2 and W3 on IFB). If room thermostat has only one stage of supplemental heat, connect white and violet wires shown in Fig. 10 to second stage heat field wire.

Some electric heaters have four control wires (plus common wire). Consult unit wiring diagram and electric heater wiring diagram for additional details.

**Leak Dissipation System**

This unit is equipped with the R-454B leak detection and dissipation system. This system is comprised of a refrigerant sensor, and dissipation control board.

The dissipation control board monitors the refrigerant sensor continuously. If a sufficient concentration of refrigerant is detected within the conditioned air stream, the dissipation board will remove any call for cooling or heating and energize continuous fan. Once the refrigerant concentration drops below the threshold, the dissipation board will do 3 things: 1) The continuous fan will remain on for 5 minutes, 2) Any call for cooling will still be removed, and 3) Any call for electrical resistance heat or gas heat (non-heat pump) will be allowed. If, after the 5 minute dissipation period, the refrigerant concentration remains below the threshold, the dissipation board will restore thermostat calls for cooling and blower operation.

**Leak Dissipation Control Board (DSB)**

The leak dissipation control board (Fig. 11) is located in the control box. There are 2 LED indicators, which are viewable after removing the control access panel (Fig. 23). The amber LED provides system status.

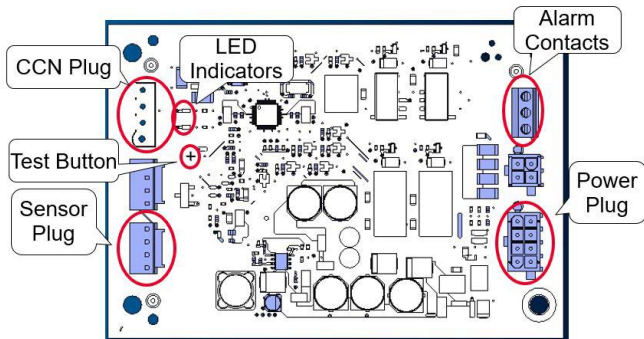

Fig. 11 – Dissipation Board

A230455

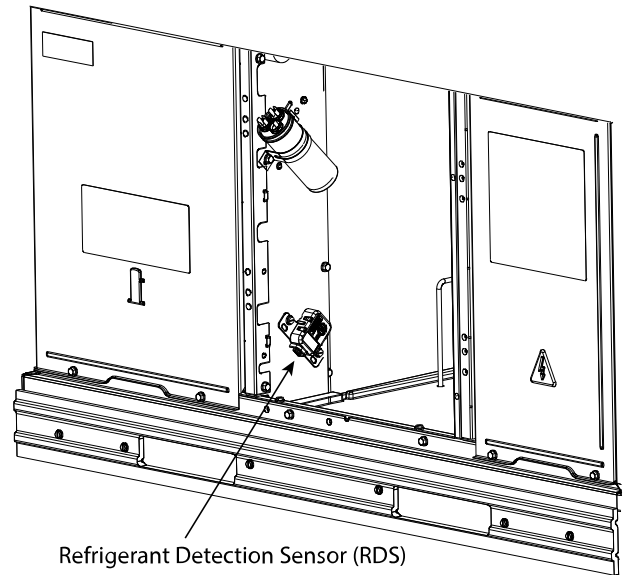

Fig. 12 – Refrigerant Detection Sensor 24 Size

A240155

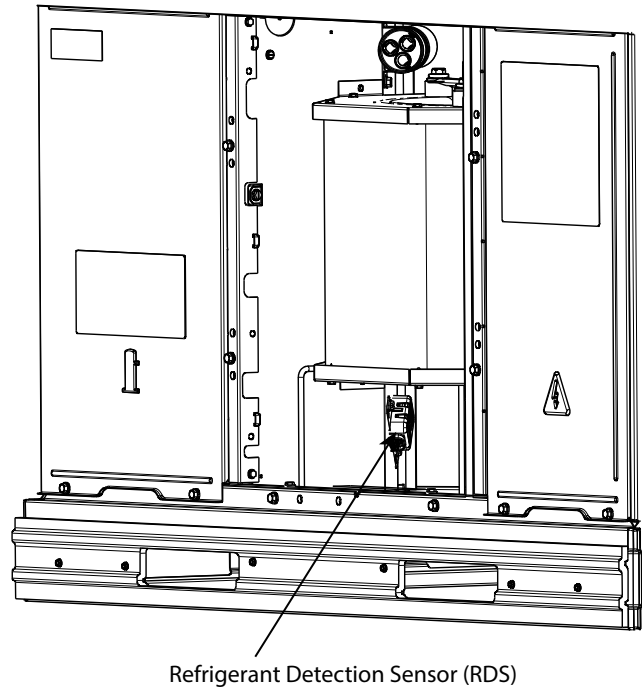

Fig. 13 – Refrigerant Detection Sensor 36-60

A240156

**Test Button**

**IMPORTANT:** Press the Test Button for approximately ONE SECOND to enter Test Mode. Pressing the Test button for a longer period can possibly clear all fault code history (Table 1).

Table 1 – Dissipation Board Test Button Functions

Hold Button Time (sec)	Function
1-4	Dissipation Mode for 60 sec
5-29	Display flash code history
30+	Flash code 6
3 rapid presses	Clear flash code history

A test button on the DSB may be used to verify proper dissipation system operation under each test condition listed below (Table 2). After pressing the test button, system will enter dissipation mode for 60 seconds to verify correct operation.

**Table 2 – Required Operational Checks to Ensure Proper Dissipation System Function**

Test #	T-Stat Call	Compressor	Indoor Fan	Electric/Gas Heat
<b>Normal Operation</b>				
1	None	Off	Off	Off
2	Cool	On	On	Off
3	Heat	Off	On	On
<b>Dissipation Activated</b>				
4	None	Off	On	Off
5	Cool	Off	On	Off
6	Heat	Off	On	Off

#### Required Minimum Dissipation Airflow

The Required Minimum Dissipation Airflow is listed in [Table 3](#), is based on refrigerant charge, and must be met or exceeded in Continuous Fan Mode. Refer to [Table 7](#) for available blower speeds and the associated CFM performance.

WARNING

**PERSONAL INJURY AND PROPERTY DAMAGE HAZARD**

Required Minimum Dissipation Airflow must be met or exceeded with the continuous fan speed selected.

#### Minimum Conditioned Space Area

The Minimum Conditioned Space Area ([Table 3](#)) is the smallest allowed area allowed to be served by this unit for proper dissipation and is based on the factory charge amount. The Minimum Conditioned Space Area must not be used in unit sizing, as the small area, will likely result in excessive short-cycling of the unit.

Example:

A 36 size unit will be installed in a residential home with a conditioned space of 1800 sq. ft. (Conditioned space to be served entirely by the unit). The following speeds are preliminarily selected by the installer with the resultant external static pressures:

- a. The Medium blower speed (Red) is selected for high stage cooling, which delivers 1199 CFM at .5 in. W.C. external static pressure.
- b. The Low blower speed (Blue) is selected for the low stage cooling speed and delivers 901 CFM at .3 in. W.C. external static pressure.

From [Table 3](#), the minimum conditioned space area for the 36 size is 137 sq. ft.. Since 1800 sq. ft. is greater than 137 sq. ft., the conditioned space is sufficient.

Also from [Table 3](#), the required minimum dissipation airflow for the 36 size unit is 239 CFM. The lowest fan speed is the low stage cooling fan speed. In this case, 901 CFM. Since 901 CFM is greater than 239 CFM, both cooling stage fan speeds are sufficient to deliver the required minimum dissipation airflow.

#### **Transformer Protection**

The transformer is of the energy-limiting type, however a direct short will likely blow a secondary fuse. If an overload or short is present, correct overload condition and check for blower fuse on Indoor Fan Board. Replace fuse as required with correct size and rating.

**Table 3 – Physical Data**

<b>UNIT SIZE</b>	<b>24</b>	<b>36</b>	<b>48</b>	<b>60</b>
NOMINAL CAPACITY (ton)	2	3	4	5
SHIPPING WEIGHT lb.	393	442	493	547
SHIPPING WEIGHT (kg)	178	201	224	248
COMPRESSORS	Scroll			
Quantity	1			
REFRIGERANT (R-454B)				
Quantity lb	8.25	8.75	10.0	15.5
Quantity (kg)	3.7	4.0	4.5	7.0
REFRIGERANT METERING DEVICE	TXV, Indoor TXV			
MINIMUM CONDITIONED SPACE AREA (SQ. FT.)	137	137	152	243
ORIFICE				
ID (in.)	.032 (2)	.035 (2)	.38 (2)	.040 (2)
ID (mm)	0.81 (2)	0.87 (2)	0.97 (2)	1.02 (2)
OUTDOOR COIL				
Rows...Fins/in.	2...21	2...21	2...21	2...21
Face Area (sq ft)	18.8	19.4	23.3	23.3
OUTDOOR FAN				
Nominal Cfm	2200	3800	3600	3600
Diameter in.	24	26	26	26
Diameter (mm)	609.6	660.4	660.4	660.4
Motor Hp (Rpm)	1/12 (800)	1/5 (810)	1/5 (810)	1/5 (810)
INDOOR COIL				
Rows...Fins/in.	3...17	3...17	3...17	4...17
Face Area (sq ft)	3.7	4.7	5.7	5.7
INDOOR BLOWER				
Required Minimum Dissipation Airflow (Cfm)	239	239	266	426
Nominal Low Stage Cooling Airflow (Cfm)	675	900	1200	1400
Nominal High Stage Cooling Airflow (Cfm)	855	1200	1600	1750
Size in.	10x10	11x10	11x10	11x10
Size (mm.)	254x254	279.4x254	279.4x254	279.4x254
Motor HP (RPM)	1/2 (1050)	3/4 (1000)	1.0 (1075)	1.0 (1075)
HIGH-PRESSURE SWITCH (psig) Cut-out Reset (Auto)	650 +/- 15 420 +/- 25			
LOW-PRESSURE SWITCH (psig) cut-out Reset (auto)	20 +/- 5 45 +/- 5			
RETURN-AIR FILTERS (Filter inside home)*				
Throwaway Size in.	20x20x1	24x30x1	24x36x1	
Throwaway Size (mm)	508x508x25	610x762x25	610x914x25	
RETURN-AIR FILTERS (Filter in Accessory Internal)				
Filter Rack in unit)* †				
Throwaway Size (in.)	2 each 12x20x1	1 each 14x24x1, 16x24x1	1 each 16x20x1, 18x20x1	
Throwaway Size (mm)	2 each 305x508x25	1 each 356x610x25, 406x610x25	1 each 406x610x25, 457x610x25	

\*. Required filter sizes shown are based on the larger of the AHRI (Air Conditioning Heating and Refrigeration Institute) rated cooling airflow or the heating airflow velocity of 300 ft/minute for throwaway type or 450 ft/minute for high-capacity type. Air filter pressure drop for non-standard filters must not exceed 0.08 in. W.C.

† If unit has an economizer, please refer to economizer accessory kit for proper filter sizes.

**Table 4 – Minimum Airflow for Safe Electric Heater Operation (CFM)**

<b>SIZE</b>	<b>24</b>	<b>36</b>	<b>48</b>	<b>60</b>
Cfm	850	1200	1600	1750

## Pre-Start-up

### **WARNING**

#### **ENVIRONMENTAL, FIRE, EXPLOSION, ELECTRICAL SHOCK HAZARD**

Failure to follow this warning could result in personal injury or death and/or property damage.

1. Follow recognized safety practices and wear protective goggles when checking or servicing refrigerant system.
2. Relieve and recover all refrigerant from system before touching or disturbing compressor plug if refrigerant leak is suspected around compressor terminals.
3. Never attempt to repair soldered connection while refrigerant system is under pressure.
4. Do not use torch to remove any component. System contains oil and refrigerant under pressure.
5. To remove a component, wear protective goggles and proceed as follows:
  - a. Shut off electrical power to unit and install lockout tag.
  - b. Relieve and reclaim all refrigerant from system using both high- and low-pressure ports.
  - c. Cut component connecting tubing with tubing cutter and remove component from unit.
  - d. Carefully unsweat remaining tubing stubs when necessary. Oil can ignite when exposed to torch flame.

Use the Start-Up Checklist supplied at the end of this book and proceed as follows to inspect and prepare the unit for initial start-up:

1. Remove all access panels (see Fig. 23).
2. Read and follow instructions on all DANGER, WARNING, CAUTION, and INFORMATION labels attached to, or shipped with unit.
3. Make the following inspections:
  - a. Inspect for shipping and handling damages, such as broken lines, loose parts, disconnected wires, etc.
  - b. Inspect for oil at all refrigerant tubing connections and on unit base. Detecting oil generally indicates a refrigerant leak. Leak test all refrigerant tubing connections using electronic leak detector, or liquid-soap solution. If a refrigerant leak is detected, see following Check for Refrigerant Leaks section.
  - c. Inspect all field- and factory-wiring connections. Be sure that connections are completed and tight. Ensure wires do not touch refrigerant tubing or sharp sheet metal edges.
  - d. Inspect coil fins. If damaged during shipping and handling, carefully straighten fins with a fin comb.
4. Verify the following conditions:
  - a. Make sure that outdoor-fan blade is correctly positioned in fan orifice.
  - b. Make sure that air filter(s) is in place.
  - c. Make sure that condensate drain pan and trap are filled with water to ensure proper drainage.
  - d. Make sure that all tools and miscellaneous loose parts have been removed
5. Each unit system has two (2) Schrader-type ports, one low-side Schrader fitting located on the suction line, and one high-side Schrader fitting located on the compressor discharge line. Be sure that caps on the ports are tight.

## Start-up

### Step 1 – Check Cooling and Heating Control Operation

Start and check the unit for proper control operation as follows:

1. Place room thermostat SYSTEM switch or MODE control in OFF position. Observe that blower motor starts when FAN mode is placed in FAN ON position and shuts down when FAN MODE switch is placed in AUTO position.

Thermostat:

On a typical two stage thermostat, when the room temperature rises 1 or 2 degrees above the cooling control setting of the thermostat, the thermostat completes the circuit between thermostat terminal R and terminals Y1, and G. These completed circuits through the thermostat connect the contactor coil (C) (through unit wire Y1) and indoor fan board (through unit wire G) across the 24-v. secondary of transformer (TRAN). On a typical two stage thermostat, when the room temperature is several degrees above the cooling control setting of the thermostat, the thermostat completes the circuit between terminal R and terminals Y1, Y2, and G.

2. If your unit contains accessory electric heat, place system switch or MODE control in HEAT position. Set control above room temperature. Observe that the indoor blower is operating and warm air is flowing through the supply air vents inside your home. Observe that the heating cycle shuts down when the control setting is satisfied.

If your unit does not contain accessory electric heat and you would like to obtain it, please contact your local dealer for more information.

3. When using an automatic changeover room thermostat place both SYSTEM or MODE control and FAN mode switches in AUTO positions. Observe that unit operates in Cooling mode when temperature control is set to “call for Cooling” (below room temperature).

**NOTE:** Once the compressor has started and then has stopped, it should not be started again until 5 minutes have elapsed.

### Step 2 – Check for Refrigerant Leaks

### **WARNING**



#### **EXPLOSION HAZARD**

Failure to follow this warning could result in death, serious personal injury, and/or property damage.

Never use air or gases containing oxygen for leak testing or operating refrigerant compressors. Pressurized mixtures of air or gases containing oxygen can lead to an explosion.

Work procedure for service:

1. All maintenance staff and others working in the local area shall be instructed on the nature of work being performed. Any nearby confined space work shall be avoided.
2. If any hot work is to be conducted on the refrigeration system or associated parts, a fire extinguisher shall be available on hand. A dry powder or CO2 fire extinguisher shall be located near the refrigerant charge recovery area.
3. Potential ignition sources, including cigarette smoking, must not be used by the technician and must be kept far away from the unit site.
4. Ensure that electrical power is available to run recovery equipment prior moving to the next step.
5. Using a R-454B leak detector, check around the area of the unit for presence of refrigerant. Note: Leak detector must be non-sparking and adequately sealed. Under no circumstances shall potential sources of ignition be used for detection of leaks, including leak detection equipment. A halide torch (or any other detector using a naked flame) shall not be used. Electronic leak detectors may be

used to detect refrigerant leaks, but in the case of R-454B, the sensitivity may not be adequate or may need re-calibration (Detection equipment shall be calibrated in a refrigerant-free area). Leak detection equipment shall be calibrated to R-454B. If a leak above 20% of the LFL is found, proceed to recovery.

6. Shut off power to unit.
7. Before beginning recovery of the refrigerant:
  - a. Make sure that handling equipment is available, if needed, to handle the refrigerant recovery cylinders.
  - b. All personal protective equipment is available, and must be used correctly.
  - c. Recovery process must be performed by an EPA-certified technician.
  - d. All recovery equipment and cylinders must conform to appropriate standards and be suitable for the recovery of FLAMMABLE REFRIGERANTS (R-454B).
8. Recovery process:  
Follow recovery process outlined in the DECOMMISSIONING SECTION.
9. Should any installation/service work on the A2L refrigerant system be needed, non-sparking tools are required. If the refrigerant system is opened, a refrigerant detector should be used to check for leaks. Open flames or other ignition sources should not be present, except during brazing. Brazing should only take place on refrigerant tubes that are open to the atmosphere or have been properly evacuated.
10. Repair leak following accepted practices.
11. If compressor or compressor oil is to be removed, ensure that they have been evacuated to 200 microns or less to make certain that R-454B does not remain within the lubricant. The evacuation process shall be carried out prior to returning the compressor to the supplier. The crankcase electric heat may be used to accelerate the compressor evacuation process. A torch must not be used. When oil is drained from a system, it shall be carried out safely.

**NOTE:** Install a new filter drier whenever the system has been opened for repair.

**NOTE:** Refrigerant cylinders used for charging must be kept in appropriate position and grounded to earth before charging. Hose length should be kept to a minimum. Care should be taken not to overcharge the system.

12. Add a small charge of R-454B refrigerant vapor to system and leak-test.
13. If no additional leaks are found, recover refrigerant from refrigerant system (Using Recovery steps outlined in the Decommissioning section) and evacuate to 500 microns.
14. Charge unit with R-454B refrigerant, using an accurate scale. Refer to unit rating plate for required charge. Do not overfill the system.
15. Label the system with the refrigerant charge amount.
16. Conduct follow-up leak test prior to leaving the job site.

### Step 3 – Start-Up Adjustments

Complete the required procedures given in the Pre-Start-Up section before starting the unit. Do not jumper any safety devices when operating the unit. Do not operate the unit in cooling mode when the outdoor temperature is below 40°F (4°C) (unless accessory low-ambient kit is installed).

**IMPORTANT:** Three-phase, scroll compressors are direction oriented. Unit must be checked to ensure proper compressor 3-phase power lead orientation. If not corrected within 5 minutes, the internal protector will shut off the compressor. The 3-phase power leads to the unit must be reversed to correct rotation. When turning backwards, the difference between compressor suction and discharge pressures may be near zero.

## Checking and Adjusting Refrigerant Charge

<b>! WARNING</b>	
	<p><b>EXPLOSION HAZARD</b></p> <p>Failure to follow this warning could result in death, serious personal injury, and/or property damage.</p> <p>Never use air or gases containing oxygen for leak testing or operating refrigerant compressors. Pressurized mixtures of air or gases containing oxygen can lead to an explosion.</p>

The refrigerant system is fully charged with R-454B refrigerant and is tested and factory sealed.

**NOTE:** Adjustment of the refrigerant charge is not required unless the unit is suspected of not having the proper R-454B charge.

A subcooling charging chart is attached to the inside of the compressor access panel. The chart includes the required liquid line temperature at given discharge line pressures and outdoor ambient temperatures.

An accurate thermocouple- or thermistor-type thermometer, and a gauge manifold are required when using the subcooling charging method for evaluating the unit charge. Do not use mercury or small dial-type thermometers because they are not adequate for this type of measurement.

**NOTE:** Allow system to operate on high stage cooling for a minimum of 15 minutes before checking or adjusting refrigerant charge.

**IMPORTANT:** When evaluating the refrigerant charge, an indicated adjustment to the specified factory charge must always be very minimal. If a substantial adjustment is indicated, an abnormal condition exists somewhere in the cooling system, such as insufficient airflow across either coil or both coils.

1. Remove caps from low- and high-pressure service fittings.
2. Using hoses with valve core depressors, attach low- and high-pressure gauge hoses to low- and high-pressure service fittings, respectively.
3. Start unit and let run until system pressures stabilize.
4. Measure and record the following:
  - a. Outdoor ambient-air temperature (°F [°C] db).
  - b. Liquid line temperature (°F [°C]) at TXV.
  - c. Discharge (high-side) pressure (psig).
  - d. Suction (low-side) pressure (psig) (for reference only).
5. Using Cooling Charging Charts (See Fig. 21) compare outdoor-air temperature (°F [°C] db) with the discharge line pressure (psig) to determine desired system operating liquid line temperature (See Fig. 21).
6. Compare actual liquid line temperature with desired liquid line temperature. Using a tolerance of  $\pm 2^{\circ}\text{F}$  ( $\pm 1.1^{\circ}\text{C}$ ), add refrigerant if actual temperature is more than  $2^{\circ}\text{F}$  ( $1.1^{\circ}\text{C}$ ) higher than proper liquid line temperature, or remove refrigerant if actual temperature is more than  $2^{\circ}\text{F}$  ( $1.1^{\circ}\text{C}$ ) lower than required liquid line temperature.

**NOTE:** If the problem causing the inaccurate readings is a refrigerant leak, refer to Check for Refrigerant Leaks section.

## Indoor Airflow and Airflow Adjustments

### WARNING

#### UNIT OPERATION HAZARD

Failure to follow this caution may result in unit damage.

For cooling operation, the recommended airflow is 350 to 450 cfm for each 12,000 Btuh of rated cooling capacity. For heating operation, the airflow must produce a temperature rise that falls within the range stamped on the unit rating plate.

**NOTE:** Be sure that all supply-air and return-air grilles are open, free from obstructions, and adjusted properly.

### WARNING

#### ELECTRICAL SHOCK HAZARD

Failure to follow this warning could result in personal injury or death.

Disconnect electrical power to the unit and install lockout tag before changing blower speed.

This unit has independent fan speeds for low stage cooling and high stage cooling. In addition, 208/230 VAC models have the field-selectable capability to run enhanced dehumidification ('DEHUM') speed in high stage cooling (as low as 320 CFM per ton). Coupled with the improved dehumidification associated with low stage cooling, the DEHUM speed allows for a complete dehumidification solution independent of cooling stage.

Table 5 shows the operation modes and the associated fan speeds with each mode for all models:

**Table 5 – Operation Modes and Fan Speeds**

Operation Mode	Fan Speed Tap Connection
Low Stage Cooling/Heat Pump	LOW
High Stage Cooling/Heat Pump	HIGH
High Stage Enhanced Dehumidification Cooling	DH
Continuous Fan	LOW

### WARNING

#### ELECTRICAL SHOCK HAZARD

Failure to follow this warning could result in personal injury or death.

Disconnect electrical power to the unit and install lockout tag before changing blower speed.

The standard evaporator fan motor is factory set to provide 5 different fan speeds to choose from for the various operation modes (see Table 6). All models are factory-shipped for nominal high stage and low stage cooling airflow operation at minimum external static pressure. See Table 4.

**Table 6 – Color Coding for Indoor Fan Motor Leads**

Black = High Speed
Orange = Med-High Speed
Red = Med Speed
Pink = Med-Low Speed
Blue = Low Speed

#### Selection of Proper Fan Speeds for Operation Modes:

**Low Stage Cooling/Heat Pump:** Using Table 7 - Table 8, find the external static pressure drops for wet coil, economizer, and filter, and add them to dry coil measured on the system. Using this total static pressure, look up Table 7 to find the airflows available at the total static pressure. Connect the chosen fan speed wire to "LO COOL" connection on the IFB Board (see Fig. 14).

**High Stage Cooling/Heat Pump:** Using Table 7 - Table 8, find the external static pressure drops for wet coil, economizer, and filter, and add them to dry coil measured on the system. Using this total static pressure, use Table 7 to find the airflows available at the total static pressure. The speed chosen must provide airflow of between 350 to 450 CFM per ton of cooling. Connect the chosen fan speed wire to "HI COOL" connection on the IFB Board (See Fig. 14).

**High Stage Enhanced Dehumidification Cooling:** Using the total static pressure for selecting the high stage cooling speed, look up Table 7 to find lower speed/airflows available at that total static pressure. All airflows highlighted in Table 7 are acceptable for the Dehum speed. The speed chosen must provide airflow of between 320 to 400 CFM per ton of cooling. To activate the high stage enhanced dehumidification cooling mode, the shunt jumper must be moved from the "No DH" to the "DH" selection. (See Fig. 14, close up.) Connect the chosen fan speed wire to "DHUM" connection on the IFB Board (see Fig. 14).

**Continuous Fan:** Continuous fan speed is the same speed as Low Stage Cooling.

**Using the Same Fan Speed for More than One Mode:** Some fan speeds are ideal for more than one mode of operation. It is permissible to use a field-supplied jumper wire to connect one speed tap wire to two or more speed connections on the Interface Fan Board (IFB). Jumper wires must use 18 AWG wire with at least 2/64" insulation.

### Sequence of Operation

#### a. Continuous Fan

- (1.) Thermostat closes circuit R to G energizing the blower motor for continuous fan. The indoor fan is energized on low speed.

#### b. Cooling Mode

- (1.) Low Stage: Thermostat closes R to G, R to Y1, and R to O. The compressor and indoor fan are energized on low speed. The outdoor fan is also energized
- (2.) High Stage: Thermostat closes R to G, R to Y1, R to Y2, and R to O. The compressor and indoor fan are energized on high speed. The outdoor fan is also energized.

#### c. Electric Heating Mode

- (1.) Thermostat closes circuit R to W2 or W3, and R to G. There are no on or off delays.

#### d. Heat Pump Heating

- (1.) Low Stage: Thermostat closes R to G, R to Y1. The compressor and indoor fan are energized on low speed. The outdoor fan is also energized
- (2.) High Stage: Thermostat closes R to G, R to Y1, R to Y2. The compressor and indoor fan are energized on high speed. The outdoor fan is also energized.

#### e. Heat Pump Heating with Auxiliary Heat

- (1.) Thermostat closes circuits R to G, R to Y and R to W/W1 or W2. The compressor, indoor and outdoor fans are energized, as well as the electric heat relays.

#### f. Defrost Mode

The defrost mode is automatically energized by the defrost board during heating mode. The defrost board energizes "O" (reversing valve) and "W2" (electric heat). It also de-energizes the outdoor fan. When defrost is complete, unit will return to heating mode. If room thermostat is satisfied during defrost, unit will shut down and restart in defrost on next call for heat.

## Step 4 – Defrost Control

### Demand Defrost Mode

The defrost mode is factory set to an initial 60-minute time interval. It may also be adjusted to an initial interval of 30, 90, or 120 minutes. During operation, the control optimizes current defrost time based on the previous defrost interval and previous defrost period. If the previous defrost period is less than 2 minutes for two consecutive defrost cycles

the control will lengthen the defrost interval by 15 minutes, up to a maximum of 120 minutes or 30 minutes greater than the original setpoint, whichever comes first. If the previous defrost period is more than 5 minutes for two consecutive defrost cycles the control will

shorten the defrost interval by 15 minutes, down to a minimum of 30 minutes or 30 minutes from the original setpoint, whichever is first. After the defrost condition is satisfied, or after a maximum of 10 minutes in defrost mode, the unit will resume normal heating operation.

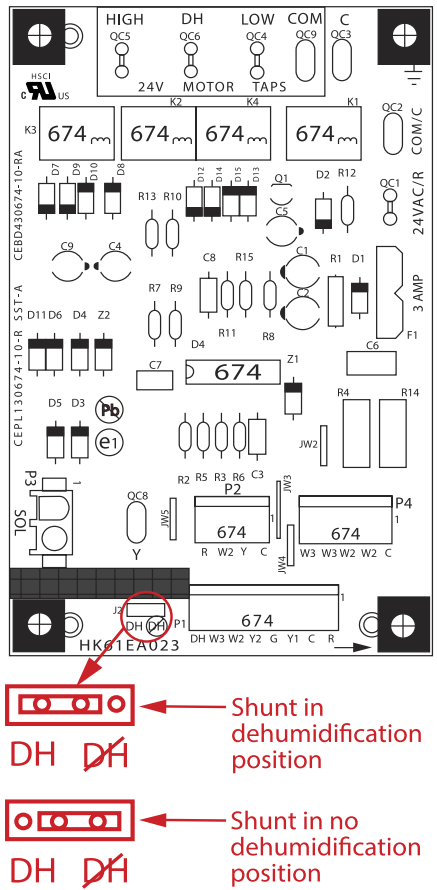

All Models

A12571

Fig. 14 – Interface Fan Board (IFB)

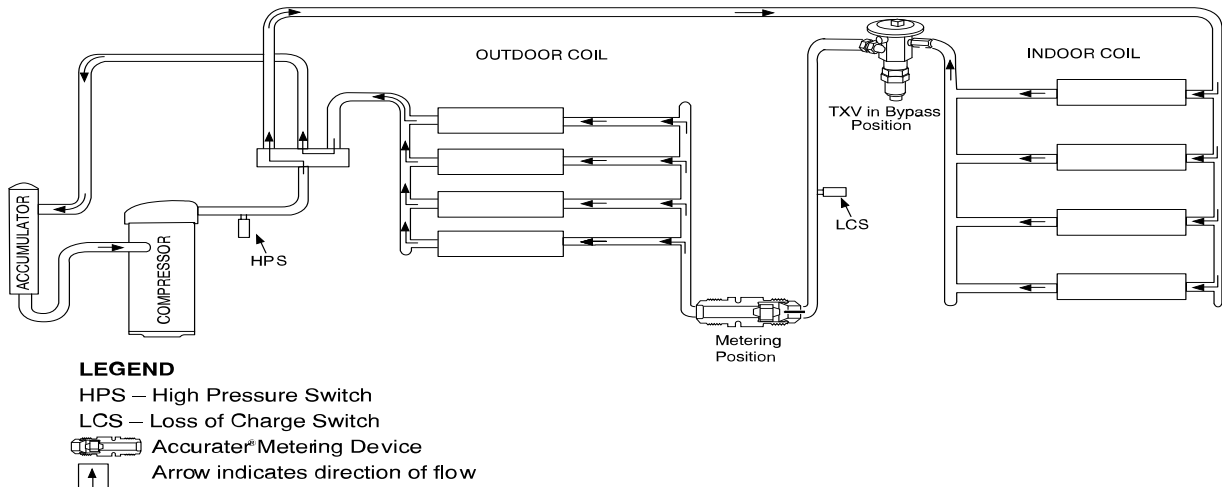

C03012

**Fig. 15 – Typical Heat Pump Operation, Heating Mode**

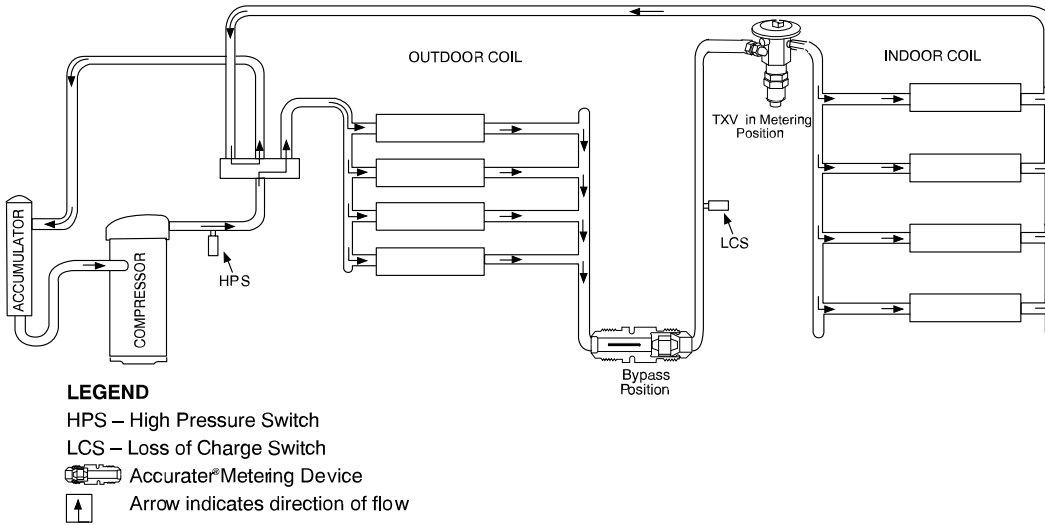

C03011

**Fig. 16 – Typical Heat Pump Operation, Cooling Mode**

Table 7 – Dry Coil Air Delivery\* - Horizontal and Downflow Discharge Sizes 24-60 208-230VAC - 1 Phase/3 Phase

Unit Size	Motor Speed	Tap	ESP (in. W.C.)										
			CFM	0.1	0.2	0.3	0.4	0.5	0.6	0.7	0.8	0.9	1
024	Low	Blue	CFM	747	663	575	473	370	289	179	NA	NA	NA
			BHP	0.10	0.11	0.11	0.12	0.12	0.13	0.13	NA	NA	NA
	Med-Low**	Pink	CFM	864	790	716	637	552	468	366	295	203	NA
			BHP	0.15	0.14	0.14	0.15	0.15	0.16	0.17	0.17	0.18	NA
	Medium	Red	CFM	1063	994	929	866	803	741	673	610	528	453
			BHP	0.21	0.22	0.23	0.23	0.24	0.25	0.25	0.26	0.26	0.27
	Med-High‡	Orange	CFM	1134	1077	1020	962	904	842	777	704	634	565
			BHP	0.27	0.27	0.28	0.29	0.30	0.30	0.31	0.32	0.32	0.33
	High	Black	CFM	1236	1187	1133	1079	1026	969	911	849	785	713
			BHP	0.33	0.34	0.35	0.35	0.36	0.37	0.38	0.39	0.39	0.39
036	Low**	Blue	CFM	1028	964	901	838	774	711	647	588	532	484
			BHP	0.12	0.13	0.14	0.15	0.15	0.16	0.17	0.18	0.19	0.19
	Med-Low	Pink	CFM	1164	1107	1051	995	939	882	824	767	711	656
			BHP	0.16	0.17	0.18	0.19	0.20	0.21	0.22	0.22	0.23	0.24
	Medium	Red	CFM	1391	1340	1294	1247	1199	1151	1104	1054	1003	946
			BHP	0.25	0.26	0.27	0.28	0.29	0.30	0.31	0.32	0.33	0.34
	Med-High‡	Orange	CFM	1423	1377	1331	1288	1240	1192	1147	1097	1047	998
			BHP	0.26	0.27	0.28	0.29	0.30	0.32	0.33	0.34	0.35	0.36
	High	Black	CFM	1511	1466	1420	1378	1338	1293	1245	1200	1156	1109
			BHP	0.30	0.31	0.33	0.34	0.35	0.36	0.37	0.38	0.39	0.40
048	Low	Blue	CFM	945	885	820	757	696	638	579	527	480	429
			BHP	0.11	0.12	0.12	0.13	0.14	0.15	0.16	0.16	0.17	0.18
	Med-Low**	Pink	CFM	1297	1253	1207	1163	1115	1066	1018	974	931	888
			BHP	0.23	0.24	0.24	0.26	0.27	0.27	0.28	0.29	0.30	0.31
	Medium‡	Red	CFM	1799	1759	1725	1676	1625	1584	1546	1509	1473	1437
			BHP	0.50	0.51	0.52	0.54	0.55	0.57	0.58	0.59	0.61	0.62
	Med-High	Orange	CFM	1936	1901	1864	1831	1798	1767	1736	1702	1670	1633
			BHP	0.63	0.64	0.65	0.66	0.68	0.69	0.70	0.71	0.73	0.74
	High	Black	CFM	1966	1933	1903	1872	1842	1811	1782	1751	1718	1619
			BHP	0.67	0.68	0.70	0.71	0.73	0.74	0.75	0.77	0.78	0.74
060	Low	Blue	CFM	897	829	764	699	641	583	521	463	407	356
			BHP	0.10	0.11	0.11	0.12	0.13	0.14	0.14	0.15	0.16	0.16
	Med-Low	Pink	CFM	1401	1364	1317	1271	1228	1189	1143	1097	1054	1012
			BHP	0.27	0.28	0.30	0.31	0.32	0.32	0.33	0.34	0.35	0.36
	Medium**	Red	CFM	1507	1472	1434	1388	1346	1307	1270	1227	1183	1142
			BHP	0.32	0.34	0.35	0.36	0.37	0.38	0.39	0.40	0.41	0.42
	Med-High‡	Orange	CFM	1943	1905	1867	1818	1787	1743	1705	1664	1624	1587
			BHP	0.63	0.64	0.66	0.67	0.68	0.69	0.70	0.71	0.73	0.74
	High	Black	CFM	1969	1939	1909	1881	1852	1817	1781	1748	1710	1613
			BHP	0.66	0.67	0.69	0.71	0.72	0.74	0.75	0.76	0.77	0.73

Shaded areas indicate speed/static combinations that are permitted for dehumidification speed.

\* - Air delivery values are without air filter and are for dry coil (See Wet Coil Pressure Drop Table).

\*\* - Factory Supplied Low Stage Cooling

‡ - Factory Supplied High Stage Cooling

NOTE: Deduct field-supplied air filter pressure drop and wet coil pressure drop to obtain static pressure available for ducting.

Manufacturer reserves the right to change, at any time, specifications and designs without notice and without obligations.

**Table 8 – Wet Coil Pressure Drop (IN. W.C.)**

Unit Size	Standard CFM (SCFM)																
	500	600	700	800	900	1000	1100	1200	1300	1400	1500	1600	1700	1800	1900	2000	2100
24	0.02	0.03	0.04	0.04	0.05	0.06											
36				0.03	0.04	0.05	0.05	0.06	0.07	0.08	0.08	0.09	0.10	0.11			
48						0.03	0.04	0.04	0.05	0.06	0.06	0.07	0.08	0.09	0.10	0.11	0.12
60						0.03	0.04	0.04	0.05	0.06	0.06	0.07	0.08	0.09	0.10	0.11	0.12

**Table 9 – Economizer with 1-in. Filter Pressure Drop (IN. W.C.)**

Filter Size in. (mm)	Cooling Tons	Standard CFM (SCFM)																
		500	600	700	800	900	1000	1100	1200	1300	1400	1500	1600	1700	1800	1900	2000	2100
600-1400 CFM 12x20x1+12x20x1 (305x508x25+305x508x25)	2.0	0.04	0.05	0.07	0.09	0.14	0.16	0.18	0.25	-	-	-	-	-	-	-	-	
1200-1800 CFM 16x24x1+14x24x1 (406x610x25+356x610x25)	3.0	-	-	-	0.04	0.06	0.07	0.08	0.10	0.11	0.12	0.13	0.14	0.16	0.16	-	-	
1500-2200 CFM 16x24x1+18x24x1 (406x610x25+457x610x25)	4.0	-	-	-	-	-	-	0.08	0.10	0.11	0.13	0.15	0.17	0.18	0.20	0.21	0.22	
1500-2200 CFM 16x24x1+18x24x1 (406x610x25+457x610x25)	5.0	-	-	-	-	-	-	0.08	0.10	0.11	0.13	0.15	0.17	0.18	0.20	0.21	0.22	

**Table 10 – Filter Pressure Drop Table (IN. W.C.)**

Filter Size in. (mm)	Cooling Tons	Standard CFM (SCFM)																
		500	600	700	800	900	1000	1100	1200	1300	1400	1500	1600	1700	1800	1900	2000	2100
600-1400 CFM 12x20x1+12x20x1 (305x508x25+305x508x25)	2.0	0.02	0.03	0.05	0.06	0.08	0.10	0.11	0.13	-	-	-	-	-	-	-	-	
1200-1800 CFM 16x24x1+14x24x1 (406x610x25+356x610x25)	3.0	-	-	-	0.03	0.03	0.04	0.05	0.06	0.07	0.08	0.09	0.09	0.10	0.11	-	-	
1500-2200 CFM 16x24x1+18x24x1 (406x610x25+457x610x25)	4.0	-	-	-	-	-	-	0.02	0.03	0.03	0.04	0.04	0.06	0.08	0.10	0.11	0.13	
1500-2200 CFM 16x24x1+18x24x1 (406x610x25+457x610x25)	5.0	-	-	-	-	-	-	0.02	0.03	0.03	0.04	0.04	0.06	0.08	0.10	0.11	0.13	

**Table 11 – Electric Heat Pressure Drop Tables (IN. W.C.)**

**Small Cabinet: 24**

STATIC	STANDARD CFM (SCFM)												
	500	600	700	800	900	1000	1100	1200	1300	1400	1500	1600	
5 kW	0.00	0.00	0.00	0.00	0.00	0.00	0.00	0.00	0.02	0.04	0.06	0.07	
10 kW	0.00	0.00	0.00	0.00	0.00	0.02	0.04	0.06	0.07	0.09	0.10	0.11	
15 kW	0.00	0.00	0.00	0.02	0.04	0.06	0.08	0.10	0.12	0.14	0.16	0.18	
20 kW	0.00	0.00	0.02	0.04	0.06	0.08	0.09	0.11	0.13	0.15	0.17	0.19	

**Large Cabinet: 36-60**

STATIC	STANDARD CFM (SCFM)														
	1100	1200	1300	1400	1500	1600	1700	1800	1900	2000	2100	2200	2300	2400	2500
5 kW	0.00	0.00	0.00	0.01	0.02	0.03	0.04	0.05	0.06	0.07	0.08	0.09	0.10	0.11	0.12
10 kW	0.00	0.00	0.01	0.02	0.03	0.04	0.05	0.06	0.07	0.08	0.09	0.10	0.11	0.12	0.13
15 kW	0.00	0.02	0.03	0.04	0.05	0.06	0.07	0.08	0.09	0.10	0.11	0.12	0.13	0.14	0.15
20 kW	0.02	0.03	0.04	0.05	0.06	0.07	0.08	0.09	0.10	0.11	0.12	0.13	0.14	0.15	0.16

Manufacturer reserves the right to change, at any time, specifications and designs without notice and without obligations.

**CONNECTION WIRING DIAGRAM**

**DANGER: ELECTRICAL SHOCK HAZARD DISCONNECT POWER BEFORE SERVICING**

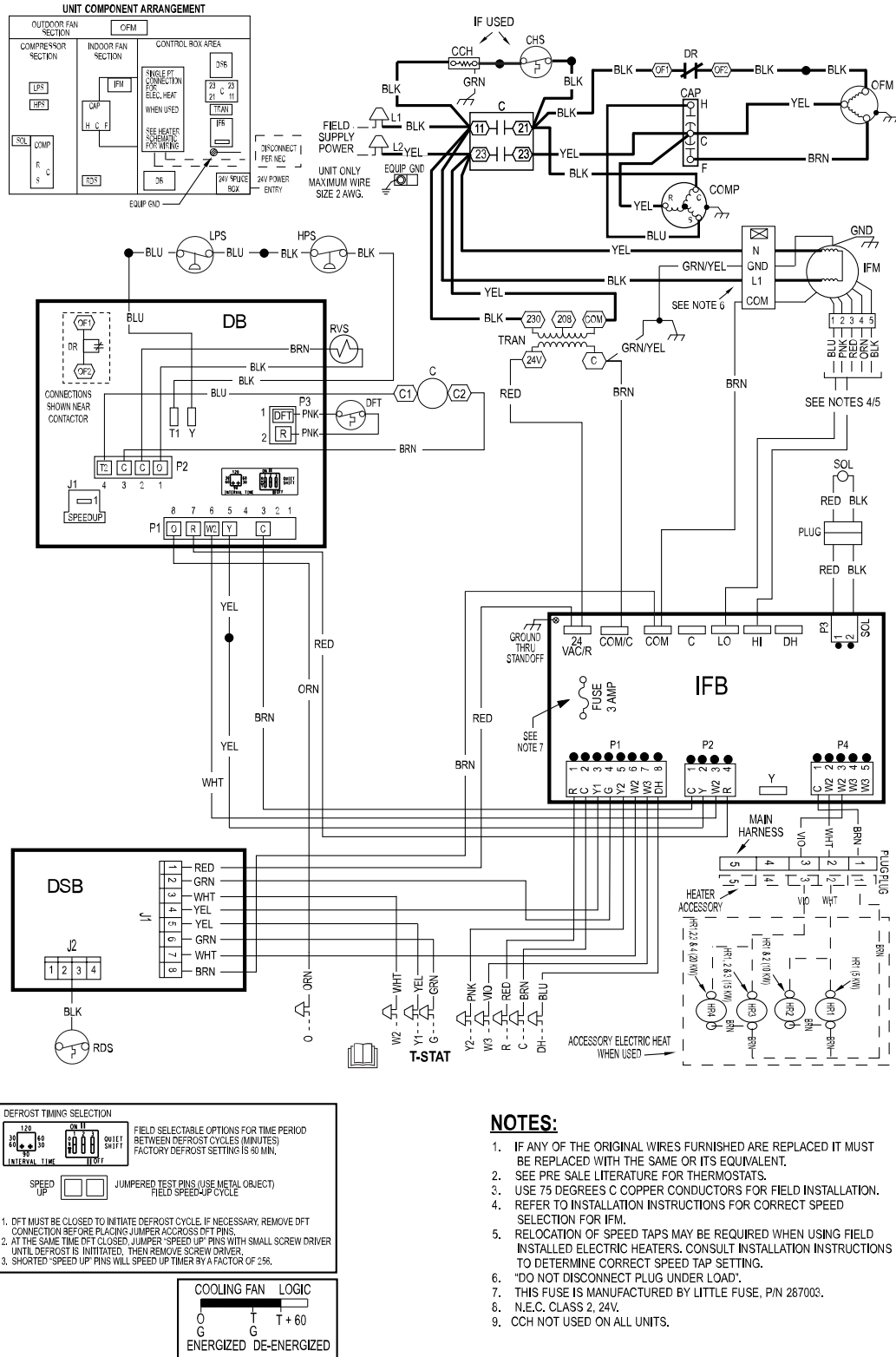

**NOTES:**

1. IF ANY OF THE ORIGINAL WIRES FURNISHED ARE REPLACED IT MUST BE REPLACED WITH THE SAME OR ITS EQUIVALENT.
2. SEE PRE SALE LITERATURE FOR THERMOSTATS.
3. USE 75 DEGREES C COPPER CONDUCTORS FOR FIELD INSTALLATION.
4. REFER TO INSTALLATION INSTRUCTIONS FOR CORRECT SPEED SELECTION FOR IFM.
5. RELOCATION OF SPEED TAPS MAY BE REQUIRED WHEN USING FIELD INSTALLED ELECTRIC HEATERS. CONSULT INSTALLATION INSTRUCTIONS TO DETERMINE CORRECT SPEED TAP SETTING.
6. "DO NOT DISCONNECT PLUG UNDER LOAD".
7. THIS FUSE IS MANUFACTURED BY LITTLE FUSE, P/N 287003.
8. N.E.C. CLASS 2, 24V.
9. CCH NOT USED ON ALL UNITS.

**Fig. 17 – Connection Wiring Diagram 208/230-1-60**



## CONNECTION WIRING DIAGRAM

**DANGER: ELECTRICAL SHOCK HAZARD DISCONNECT POWER BEFORE SERVICING**

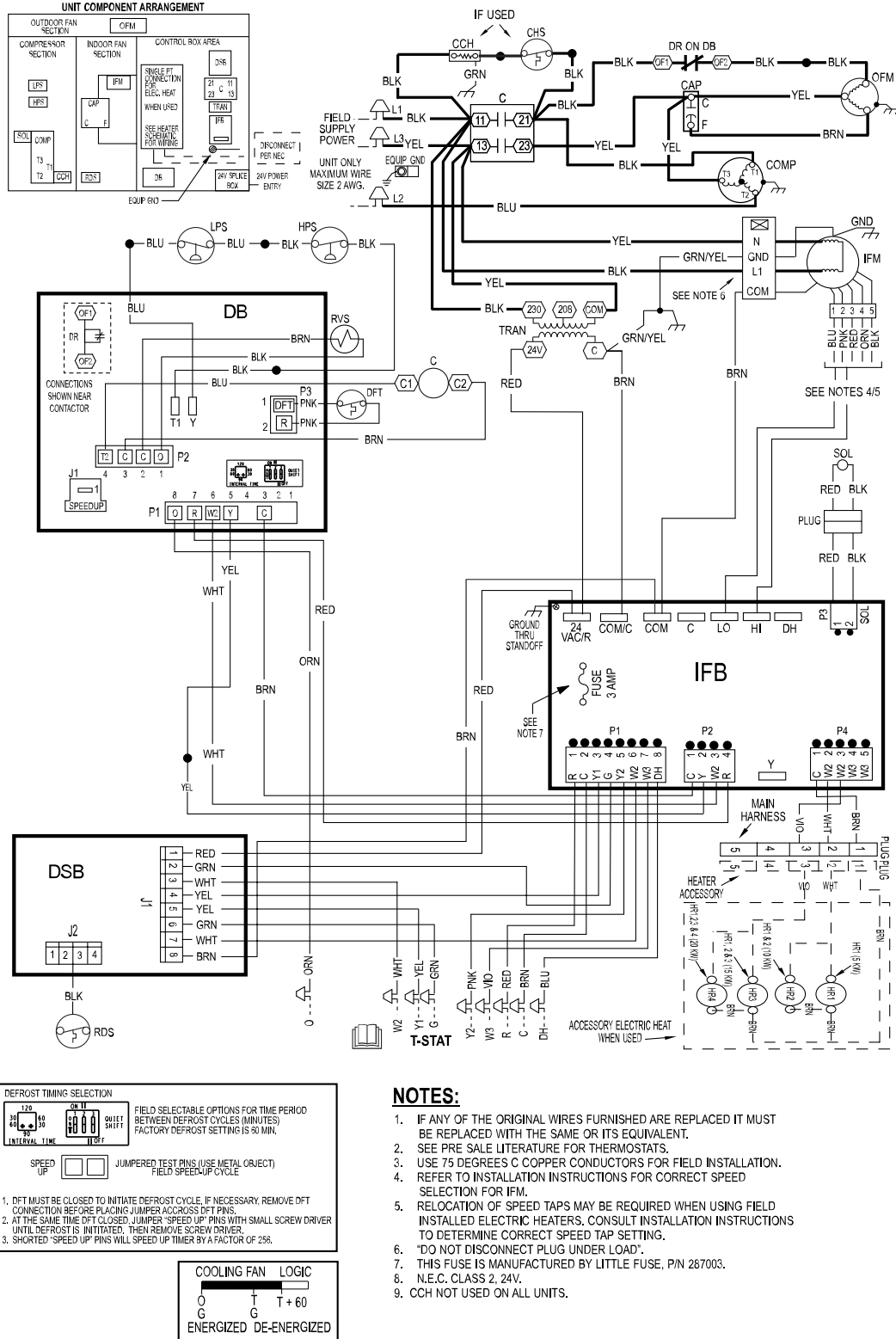

Fig. 19 – Connection Wiring Diagram 208/230-3-60



Required Subcooling °F (°C) "High Stage Cooling"						Required Liquid Line Temperature for a Specific Subcooling (R-454B)											
Model Size	Outdoor Ambient Temperature °F(°C)					Pressure (psig)	Required Subcooling (°F)					Pressure (kPa)	Required Subcooling (°C)				
	75 (24)	85 (29)	95 (35)	105 (41)	115 (46)		5	10	15	20	25		3	6	8	11	14
24	7 (3.9)	7 (3.9)	9 (3.3)	5 (2.8)	5 (2.8)	189	85	60	55	50	45	1303	18	16	13	10	7
36	11 (6.1)	11 (6.1)	11 (6.1)	11 (6.1)	11 (6.1)	196	67	62	57	52	47	1351	19	17	14	11	8
48	16 (8.9)	17 (9.4)	17 (9.4)	16 (8.9)	13 (7.2)	203	69	64	59	54	49	1399	21	18	15	12	9
60	12 (6.7)	14 (7.8)	14 (7.8)	15 (8.3)	12 (6.7)	210	71	66	61	56	51	1448	22	19	16	13	11
						217	73	68	63	58	53	1496	23	20	17	14	12
						224	75	70	65	60	55	1544	24	21	18	16	13
						231	77	72	67	62	57	1593	25	22	19	17	14
						238	79	74	69	64	59	1641	26	23	21	18	15
						245	81	76	71	66	61	1689	27	24	22	19	16
						252	83	78	73	68	63	1737	28	26	23	20	17
						260	85	80	75	70	65	1792	29	27	24	21	18
						268	87	82	77	72	67	1848	31	28	25	22	19
						276	89	84	79	74	69	1903	32	29	26	23	21
						284	91	86	81	76	71	1958	33	30	27	24	22
						292	93	88	83	78	73	2013	34	31	28	26	23
						300	95	90	85	80	75	2068	35	32	29	27	24
						309	97	92	87	82	77	2130	36	33	31	28	25
						318	99	94	89	84	79	2192	37	34	32	29	26
						327	101	96	91	86	81	2254	38	36	33	30	27
						336	103	98	93	88	83	2316	39	37	34	31	28
						345	105	100	95	90	85	2378	41	38	35	32	29
						354	107	102	97	92	87	2440	42	39	36	33	31
						364	110	105	100	95	90	2509	43	41	38	35	32
						374	111	106	101	96	91	2578	44	41	38	36	33
						384	113	108	103	98	93	2647	45	42	39	37	34
						394	115	110	105	100	95	2716	46	43	41	38	35
						404	117	112	107	102	97	2785	47	44	42	39	36
						414	118	113	108	103	98	2854	48	45	42	39	37
						424	120	115	110	105	100	2923	49	46	43	41	38
						434	122	117	112	107	102	2992	50	47	44	42	39
						444	124	119	114	109	104	3061	51	48	46	43	40
						454	126	121	116	111	106	3130	52	49	47	44	41
						464	127	122	117	112	107	3199	53	50	47	44	42
						474	129	124	119	114	109	3268	54	51	48	46	43
						484	131	126	121	116	111	3337	55	52	49	47	44
						494	132	127	122	117	112	3406	56	53	50	47	44
						504	134	129	124	119	114	3475	57	54	51	48	46
						514	136	131	126	121	116	3544	58	55	52	49	47
						524	137	132	127	122	117	3612	58	56	53	50	47
						534	139	134	129	124	119	3681	59	57	54	51	48

**Notes:**

- Subcooling values calculated using High Stage.
- System is factory-charged to provide proper subcooling performance. If system is opened or if performance issues are suspected, then subcooling must be checked.

**Charging Procedure:**

- Measure Discharge line pressure by attaching a gauge to the service port.
- Measure the Liquid line temperature by attaching a temperature sensing device to it.
- Insulate the temperature sensing device so that the Outdoor Ambient doesn't affect the reading
- Refer to the required Subcooling in the table based on the model size and the Outdoor Ambient temperature.
- Interpolate if the Outdoor Ambient temperature lies in between the table values.
- Find the Pressure Value in the table corresponding to the measured Pressure of the Compressor Discharge line.
- Read across from the Pressure reading to obtain the Liquid line temperature for a required Subcooling.
- Add Charge if the measured temperature is higher than the table value.
- Remove charge if the measured temperature is lower than the table value.



352164-701 REV. -

Fig. 21 – Cooling Charging Chart

## Maintenance

To ensure continuing high performance, and to minimize the possibility of premature equipment failure, periodic maintenance must be performed on this equipment. This cooling unit should be inspected at least once each year by a qualified service person. To troubleshoot unit, refer to [Table 12](#), Troubleshooting Chart.

NOTE TO EQUIPMENT OWNER: Consult your local dealer about the availability of a maintenance contract.

### WARNING

#### PERSONAL INJURY AND UNIT DAMAGE HAZARD

Failure to follow this warning could result in personal injury or death and possible unit component damage.

The ability to properly perform maintenance on this equipment requires certain expertise, mechanical skills, tools and equipment. If you do not possess these, do not attempt to perform any maintenance on this equipment, other than those procedures recommended in the Owner's Manual.

### WARNING

#### ELECTRICAL SHOCK AND FIRE HAZARD

Failure to follow these warnings could result in personal injury or death:

1. Turn off electrical power to the unit and install lockout tag before performing any maintenance or service on this unit.
2. Use extreme caution when removing panels and parts.
3. Never place anything combustible either on or in contact with the unit.

### CAUTION

#### UNIT OPERATION HAZARD

Failure to follow this caution may result in equipment damage or improper operation.

Errors made when reconnecting wires may cause improper and dangerous operation. Label all wires prior to disconnecting when servicing.

The minimum maintenance requirements for this equipment are as follows:

1. Inspect air filter(s) each month. Clean or replace when necessary.
2. Inspect indoor coil, drain pan, and condensate drain each cooling season for cleanliness. Clean when necessary.
3. Inspect blower motor and wheel for cleanliness each cooling season. Clean when necessary.
4. Check electrical connections for tightness and controls for proper operation each cooling season. Service when necessary.
5. Ensure electric wires are not in contact with refrigerant tubing or sharp metal edges.

### Air Filter

**IMPORTANT:** Never operate the unit without a suitable air filter in the return-air duct system. Always replace the filter with the same dimensional size and type as originally installed. See [Table 3](#) for recommended filter sizes.

Inspect air filter(s) at least once each month and replace (throwaway-type) or clean (cleanable-type) at least twice during each

cooling season and twice during the heating season, or whenever the filter becomes clogged with dust and lint.

### Indoor Blower and Motor

**NOTE:** All motors are pre-lubricated. Do not attempt to lubricate these motors.

For longer life, operating economy, and continuing efficiency, clean accumulated dirt and grease from the blower wheel and motor annually.

### WARNING

#### ELECTRICAL SHOCK HAZARD

Failure to follow this warning could result in personal injury or death. Disconnect and tag electrical power to the unit before cleaning the blower motor and wheel.

To clean the blower motor and wheel:

1. Remove and disassemble blower assembly as follows:
  - a. Remove blower access panel (see [Fig. 23](#)).
  - b. Disconnect 5 pin plug and 4 pin plug from indoor blower motor. Remove capacitor if required.
  - c. On all units remove blower assembly from unit. Remove screws securing blower to blower partition and slide assembly out. Be careful not to tear insulation in blower compartment.
  - d. Ensure proper reassembly by marking blower wheel and motor in relation to blower housing before disassembly.
  - e. Loosen setscrew(s) that secures wheel to motor shaft, remove screws that secure motor mount brackets to housing, and slide motor and motor mount out of housing.
2. Remove and clean blower wheel as follows:
  - a. Ensure proper reassembly by marking wheel orientation.
  - b. Lift wheel from housing. When handling and/or cleaning blower wheel, be sure not to disturb balance weights (clips) on blower wheel vanes.
  - c. Remove caked-on dirt from wheel and housing with a brush. Remove lint and/or dirt accumulations from wheel and housing with vacuum cleaner, using soft brush attachment. Remove grease and oil with mild solvent.
  - d. Reassemble wheel into housing.
  - e. Reassemble motor into housing. Be sure setscrews are tightened on motor shaft flats and not on round part of shaft. Reinstall blower into unit.
  - f. Connect 5 pin plug and 4 pin plug to indoor blower motor. Reinstall capacitor if required.
  - g. Reinstall blower access panel (see [Fig. 23](#)).
3. Restore electrical power to unit. Start unit and check for proper blower rotation and motor speeds during cooling cycles.

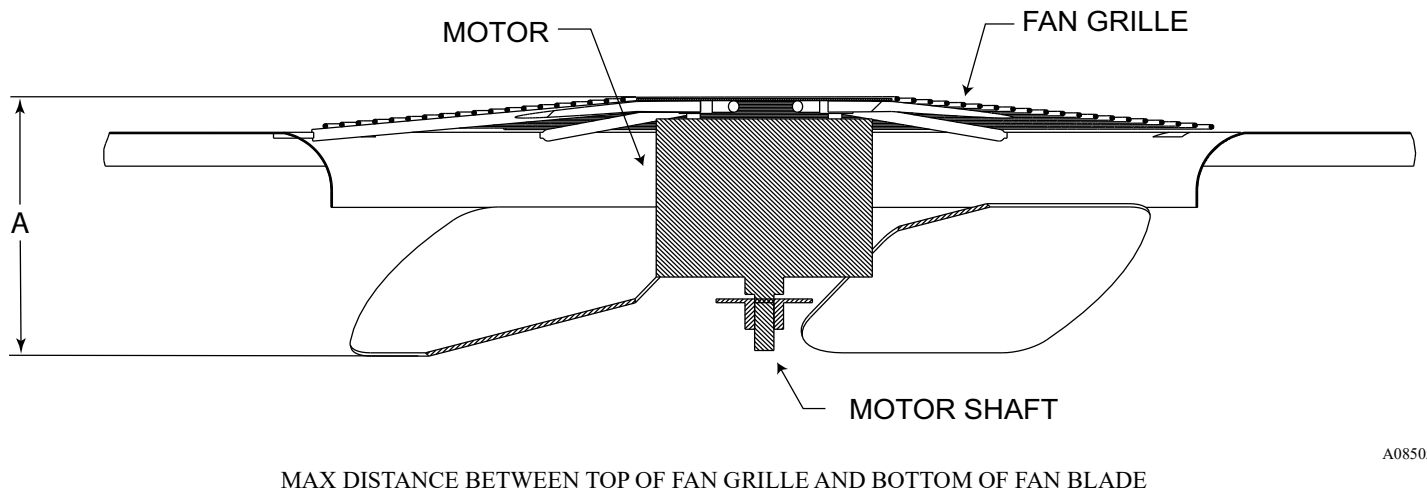

A08505

Size	"A"	
	IN.	mm
24	9.5	241
36	7.6	193
48	7.6	193
60	7.6	193

**Fig. 22 – Fan Blade Position**

Inspect the drain pan and condensate drain line when inspecting the coils. Clean the drain pan and condensate drain by removing all foreign matter from the pan. Flush the pan and drain trough with clear water. Do not splash water on the insulation, motor, wiring, or air filter(s). If the drain trough is restricted, clear it with a “plumbers snake” or similar probe device.

**Outdoor Fan**

**! CAUTION**

**UNIT OPERATION HAZARD**

Failure to follow this caution may result in damage to unit components. Keep the condenser fan free from all obstructions to ensure proper cooling operation. Never place articles on top of the unit.

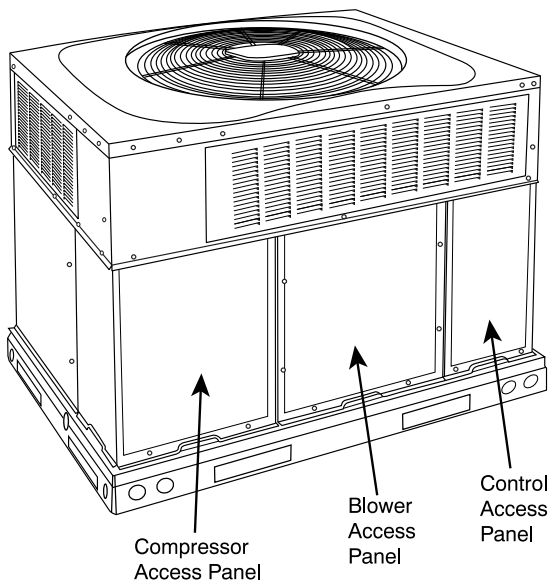

**Fig. 23 – Unit Access Panels**

A09214

**Outdoor Coil, Indoor Coil, and Condensate Drain Pan**

Inspect the condenser coil, evaporator coil, and condensate drain pan at least once each year.

The coils are easily cleaned when dry; therefore, inspect and clean the coils either before or after each cooling season. Remove all obstructions, including weeds and shrubs, that interfere with the airflow through the condenser coil.

Straighten bent fins with a fin comb. If coated with dirt or lint, clean the coils with a vacuum cleaner, using the soft brush attachment. Be careful not to bend the fins. If coated with oil or grease, clean the coils with a mild detergent and water solution. Rinse coils with clear water, using a garden hose. Be careful not to splash water on motors, insulation, wiring, or air filter(s). For best results, spray condenser coil fins from inside to outside the unit. On units with an outer and inner condenser coil, be sure to clean between the coils. Be sure to flush all dirt and debris from the unit base.

1. Remove 6 screws holding condenser grille and motor to top cover.
2. Turn motor/grille assembly upside down on top cover to expose the fan blade.
3. Inspect the fan blades for cracks or bends.
4. If fan needs to be removed, loosen the setscrew and slide the fan off the motor shaft.
5. When replacing fan blade, position blade as shown in Fig. 22.
6. Ensure that setscrew engages the flat area on the motor shaft when tightening
7. Replace grille.

**Electrical Controls and Wiring**

Inspect and check the electrical controls and wiring annually. Be sure to turn off the electrical power to the unit.

Remove access panels (see Fig. 23) to locate all the electrical controls and wiring. Check all electrical connections for tightness. Tighten all screw connections. If any smoky or burned connections are noticed, disassemble the connection, clean all the parts, restrip the wire end and reassemble the connection properly and securely.

After inspecting the electrical controls and wiring, replace the access panels (see Fig. 23). Start the unit, and observe at least one complete heating cycle and one complete cooling cycle to ensure proper operation. If discrepancies are observed in either or both operating cycles, or if a suspected malfunction has occurred, check each electrical component

with the proper electrical instrumentation. Refer to the unit wiring label when making these checkouts.

**NOTE:** Refer to the heating and/or cooling sequence of operation in this publication as an aid in determining proper control operation

### **Refrigerant Circuit**

Inspect all refrigerant tubing connections and the unit base for oil accumulations annually. Detecting oil generally indicates a refrigerant leak.

## **! CAUTION**

### **EXPLOSION, SAFETY AND ENVIRONMENTAL HAZARD**

Failure to follow this warning could result in personal injury, death or equipment damage.

This system uses R-454B refrigerant which has higher operating pressures than R-22 and other refrigerants. No other refrigerant may be used in this system. Gauge set, hoses, and recovery system must be designed to handle R-454B. If you are unsure, consult the equipment manufacturer.

If oil is detected or if low cooling performance is suspected, leak-test all refrigerant tubing using an electronic leak-detector, halide torch, or liquid-soap solution. If a refrigerant leak is detected, refer to Check for Refrigerant Leaks section.

If no refrigerant leaks are found and low cooling performance is suspected, refer to Checking and Adjusting Refrigerant Charge section.

### **Evaporator Airflow**

The heating and/or cooling air-flow does not require checking unless improper performance is suspected. If a problem exists, be sure that all supply- and return-air grilles are open and free from obstructions, and that the air filter is clean. When necessary, refer to Indoor Airflow and Airflow Adjustments section to check the system airflow.

### **Metering Device**

This unit uses 2 types of metering devices. The outdoor metering device is a fixed orifice and is contained in the brass hex-body in each liquid line feeding the outdoor coils. The indoor metering device is a TXV type device.

### **Pressure Switches**

Pressure switches are protective devices wired into the control circuit (low voltage). They shut off compressor if abnormally high or low pressures are present in the refrigeration circuit. These pressure switches are specifically designed to operate with R-454B systems. R-22 pressure switches must not be used as replacements for the R-454Bair conditioner.

### **Loss of Charge Switch**

This switch is located on the liquid line and protects against low suction pressures caused by such events as loss of charge, low airflow across indoor coil, dirty filters, etc. It opens on a pressure drop at about 20 psig. If system pressure is above this, switch should be closed. To check switch:

**NOTE:** Because these switches are attached to refrigeration system under pressure, it is not advisable to remove this device for troubleshooting unless you are reasonably certain that a problem exists. If switch must be removed, remove and recover all system charge so that pressure gauges read 0 psi (0 Pa). Never open system without breaking vacuum with dry nitrogen.

### **High-Pressure Switch**

The high-pressure switch is located in the discharge line and protects against excessive condenser coil pressure. It opens at 650 psig (31.1

kPa). High pressure may be caused by a dirty condenser coil, failed fan motor, or condenser air recirculation.

To check switch:

1. Turn off all power to unit.
2. Disconnect leads on switch.
3. Apply ohmmeter leads across switch. You should have continuity on a good switch.

### **Copeland Scroll Compressor R-454B Refrigerant)**

The compressor used in this product is specifically designed to operate with R-454B refrigerant and cannot be interchanged.

The compressor is an electrical (as well as mechanical) device. Exercise extreme caution when working near compressors. Power should be shut off, if possible, for most troubleshooting techniques. Refrigerants present additional safety hazards.

## **! WARNING**



### **EXPLOSION HAZARD**

Failure to follow this warning could result in personal injury, death or property damage.

Wear safety glasses and gloves when handling refrigerants. Keep torches and other ignition sources away from refrigerant and oils.

The scroll compressor pumps refrigerant throughout the system by the interaction of a stationary and an orbiting scroll. The scroll compressor has no dynamic suction or discharge valves, and it is more tolerant of stresses caused by debris, liquid slugging, and flooded starts. The compressor is equipped with a noise reducing shutdown device and an internal pressure relief port. The pressure relief port is a safety device, designed to protect against extreme high pressure. The relief port has an operating range between 550 (26.3 kPa) and 625 (29.9 kPa) psig differential pressure.

### **Refrigerant**

## **! CAUTION**

### **EXPLOSION, ENVIRONMENTAL HAZARD**

Failure to follow this warning could result in personal injury, death or equipment damage.

This system uses R-454B refrigerant which has higher operating pressures than R-22 and other refrigerants. No other refrigerant may be used in this system. Gauge set, hoses, and recovery system must be designed to handle R-454B. If you are unsure, consult the equipment manufacturer.

This system uses R-454B refrigerant which has higher operating pressures than R-22 and other refrigerants. No other refrigerant may be used in this system. Gage set, hoses, and recovery system must be designed to handle R-454B. If you are unsure, consult the equipment manufacturer. Failure to use R-454B compatible servicing equipment or replacement components may result in property damage or injury.

### **Compressor Oil**

The Copeland scroll compressor uses 3MAF POE oil. If additional oil is needed, use Uniqema RL32-3MAF. If this oil is not available, use Copeland Ultra 32 CC or Mobil Arctic EAL22 CC. This oil is extremely hygroscopic, meaning it absorbs water readily. POE oils can absorb 15 times as much water as other oils designed for HCFC and CFC refrigerants. Take all necessary precautions to avoid exposure of the oil to the atmosphere.

## **Servicing Systems on Roofs with Synthetic Materials**

POE (polyolester) compressor lubricants are known to cause long term damage to some synthetic roofing materials. Exposure, even if immediately cleaned up, may cause embrittlement (leading to cracking) to occur in one year or more. When performing any service that may risk exposure of compressor oil to the roof, take appropriate precautions to protect roofing. Procedures which risk oil leakage include, but are not limited to, compressor replacement, repairing refrigerant leaks, replacing refrigerant components such as filter drier, pressure switch, metering device, coil, accumulator, or reversing valve.

### **Synthetic Roof Precautionary Procedure**

1. Cover extended roof working area with an impermeable polyethylene (plastic) drip cloth or tarp. Cover an approximate 10 x 10 ft (3 x 3 m) area.
2. Cover area in front of the unit service panel with a terry cloth shop towel to absorb lubricant spills, prevent run-offs, and protect drop cloth from tears caused by tools or components.
3. Place terry cloth shop towel inside unit immediately under component(s) to be serviced and prevent lubricant run-offs through the louvered openings in the unit base.
4. Perform required service.
5. Remove and dispose of any oil contaminated material per local codes.

### **Liquid Line Filter Drier**

The filter drier is specifically designed to operate with R-454B. Use only factory-authorized components. Filter drier must be replaced whenever the refrigerant system is opened. When removing a filter drier, use a tubing cutter to cut the drier from the system. Do not unsweat a filter drier from the system. Heat from unsweating will release moisture and contaminants from drier into system.

### **R-454B Refrigerant Charging**

Refer to unit information plate and charging chart. Some R-454B refrigerant cylinders contain a dip tube to allow liquid refrigerant to flow from cylinder in upright position. For cylinders equipped with a dip tube, charge R-454B units with cylinder in upright position and a commercial metering device in manifold hose. Charge refrigerant into suction-line.

## **Step 5 – System Information**

### **Loss of Charge Switch**

The loss of charge switch is a protective device wired into control circuit (low voltage). It shuts off the compressor if abnormally low pressures are present in the refrigeration circuit.

**NOTE:** Because these switches are attached to refrigeration system under pressure, it is not advisable to remove this device for troubleshooting unless you are reasonably certain that a problem exists. If switch must be removed, remove and recover all system charge so that pressure gauges read 0 psig. Never open system without breaking vacuum with dry nitrogen.

### **Check Defrost Thermostat**

The defrost thermostat is usually located on the lowest liquid leaving circuit of the left condenser coil (see Fig. 24). The thermostat closes at 32°F (0°C) and opens at 65°F (18°C).

The defrost thermostat signals heat pump that conditions are right for defrost or that conditions have changed to terminate defrost. It is a thermally actuated switch clamped to outdoor coil to sense its temperature. Normal temperature range is closed at 32° ± 3°F (0 ± 1.7°C) and open at 65° ± 5°F (18 ± 2.8°C).

**NOTE:** The defrost thermostat must be located on the liquid side of the outdoor coil on the bottom circuit and as close to the coil as possible.

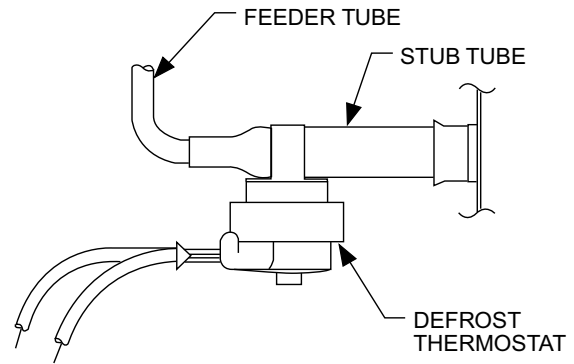

Fig. 24 – Defrost Thermostat

C99029

## **Troubleshooting**

Refer to the Troubleshooting Chart (Table 12) for troubleshooting information.

## **Start-up Checklist**

Use the Start-Up Checklist at the back of this manual.

Table 12 – Troubleshooting Chart

SYMPTOM	CAUSE	REMEDY
Compressor and outdoor fan will not start	Power failure	Call power company
	Fuse blown or circuit breaker tripped	Replace fuse or reset circuit breaker
	Defective contactor, transformer or high-pressure, loss-of-charge or low-pressure switch	Replace component
	Insufficient line voltage	Determine cause and correct
	Incorrect or faulty wiring	Check wiring diagram and rewire correctly
	Thermostat setting too high	Lower thermostat setting below room temperature
Compressor will not start but condenser fan runs	Faulty wiring or loose connections in compressor circuit	Check wiring and repair or replace
	Compressor motor burned out, seized, or internal overload open	Determine cause Replace compressor
	Defective run/start capacitor, overload, start relay	Determine cause and replace
Three-phase scroll compressor (size 36-60 unit) has a low pressure differential	Scroll compressor is rotating in the wrong direction	Correct the direction of rotation by reversing the 3-phase power leads to the unit
Compressor cycles (other than normally satisfying thermostat)	Refrigerant overcharge or undercharge	Recover refrigerant, evacuate system, and recharge to capacities shown on rating plate
	Defective compressor	Replace and determine cause
	Insufficient line voltage	Determine cause and correct
	Blocked condenser	Determine cause and correct
	Defective run/start capacitor, overload or start relay	Determine cause and replace
	Defective thermostat	Replace thermostat
	Faulty condenser-fan motor or capacitor	Replace
	Restriction in refrigerant system	Locate restriction and remove
Compressor operates continuously	Dirty air filter	Replace filter
	Unit undersized for load	Decrease load or increase unit size
	Thermostat set too low	Reset thermostat
	Low refrigerant charge	Locate leak, repair, and recharge
	Mechanical damage in compressor	Replace compressor
	Air in system	Recover refrigerant, evacuate system, and recharge
	Condenser coil dirty or restricted	Clean coil or remove restriction
Excessive head pressure	Dirty air filter	Replace filter
	Dirty indoor or outdoor coil	Clean coil
	Refrigerant overcharged	Recover excess refrigerant
	Air in system	Recover refrigerant, evacuate system, and recharge
Head pressure too low	Low refrigerant charge	Check for leaks, repair and recharge
	Compressor IPR leaking	Replace compressor
	Restriction in liquid tube	Remove restriction
Excessive suction pressure	High heat load	Check for source and eliminate
	Compressor IPR leaking	Replace compressor
	Refrigerant overcharged	Recover excess refrigerant
Suction pressure too low	Dirty air filter	Replace filter
	Low refrigerant charge	Check for leaks, repair and recharge
	Metering device or low side restricted	Remove source of restriction
	Insufficient evaporator airflow	Increase air quantity Check filter—replace if necessary
	Temperature too low in conditioned area	Reset thermostat
	Outdoor ambient below 55°F (12.7°C)	Install low-ambient kit
	Filter drier restricted	Replace filter

## STATUS CODE DESCRIPTION FOR DISSIPATION BOARD

FLASH CODE CHART			PIN	COLOR	1-Stage Unit	2-Stage Unit
<b>Yellow LED</b>	<b>Reason</b>	<b>Mode</b>	1	Red	to unit 24VAC	to unit 24VAC
Solid	Normal Operation	Normal Operation	2	Green	to SPP unit G	to SPP unit G
Flashing 1	Sensor >= 20% LFL	Dissipation	3	White	to TSTAT W	to TSTAT W1
Flashing 2	Sensor Open	Dissipation	4	Yellow	to SPP unit Y	to SPP unit Y1
Flashing 3	Normal Dissipation After Leak	Dissipation	5	Yellow	to TSTAT Y	to TSTAT Y1
Flashing 4	No Power to G Output	Dissipation w/o Blower	6	Green	to TSTAT G	to TSTAT G
Flashing 5	Fault with A2L Digital Sensor	Dissipation	7	White	to SPP unit W	to SPP unit W1
Flashing 6	Test Button Stuck (>30s)	Dissipation	8	Brown	to unit COM	to unit COM
Flashing 7	Y or W Wiring Inverted	Normal Operation	<b>See Installation Instructions For Specific Details**</b>			
Flashing 8	Y or W Shorted	Normal Operation				

350502-201 REV. -



A240111

### Start-Up Checklist

(Remove and Store in Job Files)

#### I. PRELIMINARY INFORMATION

MODEL NO.: \_\_\_\_\_

SERIAL NO.: \_\_\_\_\_

DATE: \_\_\_\_\_

TECHNICIAN: \_\_\_\_\_

#### II. PRESTART-UP (Insert check mark in box as each item is completed)

- ( ) VERIFY THAT ALL PACKING MATERIALS HAVE BEEN REMOVED FROM UNIT
- ( ) REMOVE ALL SHIPPING HOLD DOWN BOLTS AND BRACKETS PER INSTALLATION INSTRUCTIONS
- ( ) CHECK ALL ELECTRICAL CONNECTIONS AND TERMINALS FOR TIGHTNESS
- ( ) CHECK THAT INDOOR (EVAPORATOR) AIR FILTER IS CLEAN AND IN PLACE
- ( ) VERIFY THAT UNIT INSTALLATION IS LEVEL
- ( ) CHECK FAN WHEEL, AND PROPELLER FOR LOCATION IN HOUSING/ORIFICE AND SETSCREW TIGHTNESS
- ( ) INSPECT TUBING

#### III. START-UP

##### ELECTRICAL

SUPPLY VOLTAGE \_\_\_\_\_

COMPRESSOR AMPS \_\_\_\_\_

INDOOR (EVAPORATOR) FAN AMPS \_\_\_\_\_

##### TEMPERATURES

OUTDOOR (CONDENSER) AIR TEMPERATURE \_\_\_\_\_ DB

RETURN-AIR TEMPERATURE \_\_\_\_\_ DB \_\_\_\_\_ WB

COOLING SUPPLY AIR \_\_\_\_\_ DB \_\_\_\_\_ WB

HEAT PUMP SUPPLY AIR \_\_\_\_\_

ELECTRICAL HEAT SUPPLY AIR \_\_\_\_\_

##### PRESSURES

REFRIGERANT SUCTION \_\_\_\_\_ PSIG, SUCTION LINE TEMP\* \_\_\_\_\_

REFRIGERANT DISCHARGE \_\_\_\_\_ PSIG, LIQUID TEMP† \_\_\_\_\_

- ( ) VERIFY REFRIGERANT CHARGE USING CHARGING CHARTS

\* Measured at suction inlet to compressor

† Measured at liquid line leaving condenser.

## Decommissioning

This unit is designed to provide many years of comfort. Eventually, this unit will need to be replaced.

Work procedure for decommissioning:

1. All maintenance staff and others working in the local area shall be instructed on the nature of work being performed. Any nearby confined space work shall be avoided.
2. If any hot work is to be conducted on the refrigeration system or associated parts, a fire extinguisher shall be available on hand. A dry powder or CO2 fire extinguisher shall be located near the refrigerant charge recovery area.
3. Potential ignition sources, including cigarette smoking, must not be used by the technician and must be kept far away from the unit site.
4. Ensure that electrical power is available to run recovery equipment prior moving to the next step.
5. Using a R-454B leak detector, check around the area of the unit for presence of refrigerant. Note: Leak detector must be non-sparking and adequately sealed.
6. Shut off main gas shut-off valve to appliance.
7. Shut off power to unit and install lockout tag on the electrical whip to the unit.
8. Remove gas line to gas valve and cap.
9. Before beginning recovery of the refrigerant:
  - a. Make sure that handling equipment is available, if needed, to handle the refrigerant recovery cylinders.
  - b. All personal protective equipment is available, and must be used correctly.
  - c. Recovery process must be performed by an EPA-certified technician.
  - d. All recovery equipment and cylinders must conform to appropriate standards and be suitable for the recovery of FLAMMABLE REFRIGERANTS (R-454B).
10. Recovery process:
  - a. Technician must be present during the entire recovery process.
  - b. Use a recovery cylinder that is for R-454B and do not mix refrigerants. If possible, use an empty cylinder and cool before use. Cylinders shall be complete with pressure-relief valve and associated shut-off valves in good working order. Make sure the recovery cylinder is situated on the scale prior to recovery.
  - c. Note the original charge amount listed on the rating plate. Make sure that there are sufficient recovery cylinders available to recover all the charge.
  - d. Before using the recovery machine, check that it is suitable for use with FLAMMABLE REFRIGERANTS (R-454B), is in satisfactory working order, has been properly maintained, and associated electrical components are sealed to prevent ignition in

- the event of a refrigerant release. If there are any doubts, please contact the recovery machine manufacturer before using.
- e. Connect recovery equipment to gauge ports on unit and to the recovery cylinder.
  - f. In accordance with all recovery machine instructions, begin the recovery machine.
  - g. Cylinders must not be overfilled (No more than 80% volume liquid charge). Do not exceed the maximum working pressure of the cylinder.
  - h. When the cylinders have been filled correctly and the evacuation process is complete, close all cylinder valves are closed off.
  - i. Record the amount of R-454B refrigerant recovered and note on the logs of each cylinder used.
  - j. Cut out the form below and fill out, sign, and date. Affix the form in a prominent location on the unit using tape.

<b>DECOMMISSIONED</b>
Model Number:
Serial Number:
<b>UNIT EMPTIED OF REFRIGERANT</b>
Date:
Signature:

- k. If refrigerant was **not** recovered in decommission process. Do not fill out the decommissioned label above. Ensure all A2L labeling is still on unit.
- l. Recovered refrigerant shall not be charged into another REFRIGERATING SYSTEM unless it has been cleaned and checked.
- m. Recovered refrigerant shall be returned to the refrigerant supplier in the correct recovery cylinder, and the relevant waste transfer note arranged. Do not mix refrigerants in recovery systems, and especially not in cylinders.
- n. If compressors or compressor oils are to be removed, ensure that they have been evacuated to 200 microns or less to make certain that R-454B does not remain within the lubricant. The evacuation process shall be carried out prior to returning the compressor to the supplier. The crankcase electric heat may be used to accelerate the compressor evacuation process. A torch must not be used. When oil is drained from a system, it shall be carried out safely.

### Training

My Learning Center is your central location for professional residential HVAC training resources that help strengthen careers and businesses. We believe in providing high quality learning experiences both online and in the classroom.

Access My Learning Center with your HVACpartners credentials at [www.mlctraining.com](http://www.mlctraining.com). Please contact us a [mylearning@carrier.com](mailto:mylearning@carrier.com) with questions.